

RADIO TEST REPORT

(for Bluetooth classic)

Project No. : JB-Z0417-A
 Client : Sony Corporation
 Address : 1-7-1 Konan Minato-ku Tokyo, 108-0075 Japan
 Type of Equipment : Communication Module
 Model No. : FLE01WBM
 FCC ID : AK8FLE01WBM
 Regulation Applied : 47 CFR Part 15 Subpart C
Final Judgment : **Passed**
 Sample Receipt : May 14, 2018
 Testing : May 31, 2018 - August 23, 2018
 Original Reported : July 24, 2018
 Amend Reported : August 24, 2018

Amend:

Original report JB-Z0417 is replaced to this report for the following reasons:
 - Re-measurement the Carrier Frequency Separation measurement

Reported by :

Approved Signatory :

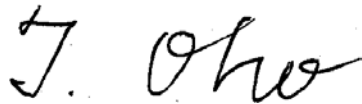

Takanori Oho
 Technical Manager
 EMC/RF Test Laboratory, Main Lab.
 Design Technology Division
 Sony Global Manufacturing & Operations Corporation

Teruki Kurihara
 Technical Manager
 EMC/RF Test Laboratory, Main Lab.
 Design Technology Division
 Sony Global Manufacturing & Operations Corporation

Notice

* These test results relate only to the items (combination equipment, test configuration, operation condition etc.) tested.

* This report shall not be reproduced except in full, without written approval of the laboratory.

* This report must not be used by the client to claim product endorsement by A2LA or any agency of the U.S. Government.

* All test results are traceable to the national and / or international standards.

The testing in which "Non-accreditation" is displayed is outside the accreditation scopes in Sony Global Manufacturing & Operations Corporation EMC/RF Test Laboratory.



TABLE OF CONTENTS

- 1. General Information..... 3**
 - 1.1. Description of Equipment Under Test (EUT)..... 3
 - 1.2. Summary of Test Result..... 4
 - 1.3. Tested Methodology 5
 - 1.4. Measurement Procedures 5
 - 1.5. Test Facility..... 8
 - 1.6. Uncertainty 9
- 2. System Test Configuration 10**
 - 2.1. Validation 10
 - 2.2. Test Operating Conditions 10
 - 2.3. EUT Modifications 11
 - 2.4. Configuration of Tested System 12
- 3. Test Data..... 15**
 - 3.1. AC Power-line Conducted Emissions 15
 - 3.2. 20dB Bandwidth..... 16
 - 3.3. Carrier Frequency Separation..... 18
 - 3.4. Number of Hopping Frequencies 19
 - 3.5. Time of Occupancy (Dwell Time)..... 20
 - 3.6. Maximum Peak Conducted Output Power..... 23
 - 3.7. Radiated Spurious Emissions..... 24
 - 3.8. Conducted Spurious Emissions for Band Edge..... 64
- 4. Method of Calculation 65**
- 5. List of Test Equipment..... 67**
 - 5.1. AC Power-line Conducted Emissions 67
 - 5.2. Antenna-port Conducted Measurements..... 67
 - 5.3. Radiated Spurious Emissions..... 68
- 6. Photographs of test setup..... 69**
 - 6.1. AC Power-line Conducted Emissions Measurements Photo(s)..... 69
 - 6.2. Antenna-port Conducted Measurements Photo(s) 69
 - 6.3. Radiated Spurious Emissions Measurement Photo(s)..... 70

Note

- indicates that the listed condition, standard or equipment is applicable for this report.
- indicates that the listed condition, standard or equipment is not applicable for this report.

1. General Information

1.1. Description of Equipment Under Test (EUT)

General specification

Test Sample Condition : Prototype Pre-production Mass-production
Type of Equipment : Communication Module
Trade Name : SONY
Model No. : FLE01WBM
Serial No. : 1
Power Rating : DC 3.3 V (The EUT was supplied with the power from the host device)

Similar model(s) to be covered by this report

Model No. : None

Radio specification

Function of the Equipment : Transceiver
Operating Frequency : 2402 - 2480MHz
Modulation Type : FHSS (GFSK, $\pi/4$ DQPSK, 8DPSK)
Channel Spacing : 1MHz
Channel Bandwidth : 1MHz
Number of channels : 79
Antenna Type : Inverted-F Antenna
Antenna connector Type : None
Antenna Gain : 1.1 dBi
Operating Temperature : -30 to +85 deg.C

1.2. Summary of Test Result

Test Item	Worst Margin	Test Frequency band	Results
AC Power-line Conducted Emissions	23.2 dB (AV) 9.408 MHz N	150 kHz - 30 MHz	Complied
20dB Bandwidth	Refer to the test data	Carrier	Complied
Carrier Frequency Separation	Refer to the test data	Carrier	Complied
Number of Hopping Frequencies	Refer to the test data	Carrier	Complied
Time of Occupancy (Dwell Time)	Refer to the test data	Carrier	Complied
Maximum Peak Conducted Output Power	26.53 dB	Carrier	Complied
Radiated Spurious Emissions	13.5 dB (AV) 3555.242 MHz Vertical	9 kHz - 25 GHz (excluding carrier and band edge)	Complied
Conducted Spurious Emissions for Band Edge *1	29.38 dB 2399.63 MHz	Carrier band edge	Complied

*1: Conducted Spurious Emission was tested for the only frequencies in the non-restricted carrier band edges, since the spurious emissions in other non-restricted band were complied with Radiated Spurious Emission measurement.

Other requirements

Part 15.31(e) Supply voltage requirement

: Complied (The EUT is provided with stable DC 3.3V from the host device)

Part 15.203 / 212 Antenna requirement

: Complied

(Users cannot replace the external antenna, since it is mounted to the EUT inside)

1.3. Tested Methodology

Test Standard : 47 CFR Part15 Subpart C Section 15.207 / 15.247
 Test Method : ANSI C63.10 - 2013
 DA 00-705 (March 30, 2000)

Test Condition

AC Power-line Conducted Emissions

Dimensions of the EUT table : 0.8m height, 2m width and 1m depth.

Radiated Spurious Emissions

Test Distance : 3 m 10m (9kHz - 30 MHz)
 3 m 10m (30 - 1000 MHz)
 3 m (1 - 25 GHz)

Dimensions of the EUT table

Below 1GHz : 0.8 m height, 0.5 m width and 1 m depth.
 Above 1GHz : 1.5 m height, 2 m width and 1 m depth.

1.4. Measurement Procedures

We performed the measurements in accordance with NV3-12, available upon the request.

- No deviation
 Deviation from the above procedure

The summary of the above procedure is mentioned below

Antenna-port Conducted Measurements

1. Antenna-port of the EUT was connected to the power sensor (Maximum peak conducted output power) or spectrum analyzer. (other test items).
2. For each EUT operation mode, the Antenna-port Conducted Measurements were measured with spectrum analyzer.

Test Item	Detector	RBW
* Antenna-port Conducted Measurements		
20dB Bandwidth	Peak	30 kHz
Carrier Frequency Separation	Peak	100 kHz
Number of Hopping Frequencies	Peak	100 kHz
Time of Occupancy (Dwell Time)	Peak	1 MHz
Maximum Peak Conducted Output Power	Peak	N/A
Conducted Spurious Emissions for Band Edge	Peak	100 kHz

AC Power-line Conducted Emissions

1. The non-conductive table (EUT table) made of (FRP, wood, other non-conductive material) was placed 0.4 m from its rear to the vertical reference ground plane.
2. The EUT was placed on the center of tabletop and its rear was flush with the rear of the table, connected through a LISN to the input power mains.
3. The LISN was placed in 80 cm from the nearest part of the EUT chassis.
4. The excess length of the AC cable between the EUT and the LISN receptacle, or an adaptor or extension cable connected to and measured with LISN, was folded back and forth at the center of the lead to form a bundle not exceeding 40 cm in length.
5. The connection of the all other equipment to the second LISN was performed. The second LISN was terminated with a 50-ohm terminator.
6. Interconnecting cables that hang closer than 40 cm to the horizontal reference ground plane was folded back and forth forming a bundle 30 to 40 cm long, hanging approximately in the middle between the horizontal reference ground plane and the tabletop.
7. Find the worst mode and arrangement of the EUT according to the follows;
 - Connecting all peripherals and change the position of peripherals and cables.
 - Changing the all test operation modes of the EUT.
 - On every condition, exploring the highest emissions with the spectrum analyzer.
(150kHz - 30MHz, peak detector, RBW: 10 kHz)
8. On the worst condition of the EUT found in above, choose the 6 highest emissions on the spectrum data. The final measurements carried out on these emissions with EMI test receiver.
(quasi-peak and average detector, RBW: 9 kHz)

Radiated Spurious Emissions

1. The non-conductive table (EUT table) made of (FRP, Styrene Foam, other non-conductive material) was placed in the center of the turntable.
2. The EUT was placed on the center of the tabletop.
3. The test antenna was placed away from the EUT at test distance.
4. The limits were compensated the distance factor with follows:
 9 kHz - 490 kHz [Limit at 3m] = [Limit at 300m] + 40log (300[m] / 3[m])
 490 kHz - 30 MHz [Limit at 3m] = [Limit at 30m] + 40log (30[m] / 3[m])
5. Find the worst arrangement of the EUT according to follows;
 - Rotating the turntable and/or scanning the antenna.
 - On every condition, exploring the highest emissions with the spectrum analyzer. (9 kHz - 25 GHz, peak detector)
6. On the worst arrangement of the EUT found in above, choose the three highest harmonics or spurious emissions on the spectrum data.(*excluding carrier band edges)
 The final measurements of all test operating modes carried out on these emissions as follows;

The test antenna and the turntable were performed with follows;

	9kHz - 30MHz	30MHz - 1000MHz	1GHz - 25GHz
Antenna	Loop Antenna	Bi-conical Antenna, Log-periodic Antenna	Horn Antenna
Antenna scanning range	1m, Vertical, 360 degrees	1 - 4m, Horizontal and Vertical	1 - 4m *, Horizontal and Vertical
Turntable rotating range	360 degrees	360 degrees	360 degrees

*: Final measurements are performed keeping the antenna in the "cone of radiation" from EUT area and pointed at the area both in azimuth and elevation, with polarization oriented for maximum response.

Instruments settings were carried out with follows;

	9 kHz - 90 kHz 110 kHz - 490 kHz	90 kHz- 110 kHz 490 kHz - 30 MHz	30 MHz - 1000 MHz	1GHz - 25GHz
Detector	Peak / Average	Quasi-peak	Quasi-peak	Peak / Average
RBW	9 kHz (6 dB) *1	9 kHz (6 dB) *1	120 kHz (6 dB)	1 MHz (6 dB)
VBW	N/A	N/A	N/A	3 MHz (for peak) 10 Hz (for average) *2
Instrument	EMI test receiver	EMI test receiver	EMI test receiver	Spectrum analyzer

*1: When the measurement frequencies below 150 kHz, RBW: 200 Hz was used.

*2: VBW setting (for average) was higher than 1/T. (T is the minimum transmission duration)

7. If the final measurement result exceeded the limit(FCC 15.209(a)) in non-restricted band(excluding carrier band edges), the measurement is carried out additionally and compared with the limit (-20dBc) with follows;

Measurement points

- Fundamental Frequency
- Frequency that exceeded the limit in non-restricted band (excluding carrier band edges)

	9 kHz - 150 kHz	150 kHz - 30MHz	30MHz - 25GHz
Detector	Peak	Peak	Peak
RBW	3 dB RBW: 300 Hz *	3 dB RBW: 10 kHz *	3 dB RBW: 100 kHz
Instrument	Spectrum analyzer	Spectrum analyzer	Spectrum analyzer

*: Correction factor of RBW was compensated to a measurement result by the following formula.

$$C.F. \text{ of RBW [dB]} = 10 * \log (100\text{kHz} / \text{used RBW})$$

8. Although these tests were performed other than open field area test site, adequate comparison measurements were confirmed against 30 m open field area test site. Therefore sufficient tests were made to demonstrate that the alternative site produces results that correlate with the ones of tests made in an open field based on KDB 414788 D01.

1.5. Test Facility

Address of Test Facility

Test Facility Name : Sony Global Manufacturing & Operations Corporation
EMC/RF Test Laboratory, Main Lab.
Address : Kisarazu Site 8-4 Shiomi Kisarazu-shi, Chiba, 292-0834 Japan
Phone : +81 438 37 2750

AC Power-line Conducted Emissions

Shielded Room

4th Site EMC Site

Radiated Spurious Emission

Semi-Anechoic chamber

4th Site EMC Site

Antenna-port Conducted Measurements *

Shielded Room

4th Site SR1

*Note: This item contains the following

- 20dB Bandwidth
- Carrier Frequency Separation
- Number of Hopping Frequencies
- Time of Occupancy (Dwell Time)
- Maximum Peak Conducted Output Power
- Conducted Spurious Emissions for Band Edge

A2LA Accreditation for Test Facility

The above test facility has been fully reported to A2LA and accepted as follows:

A2LA Certificate No. : 3203.01
Cert. Validated Date : 31 Oct 2019

1.6. Uncertainty

Test Item	Frequency	4th Site SR1
Conducted Output Power	1 - 6GHz	± 0.84 dB
Conducted Spurious Emissions	1 - 6GHz	± 1.25 dB

Test Item	Frequency	Distance	4th Site
AC Power-line Conducted Emissions	150kHz - 30MHz	-	± 3.34 dB
Radiated Emissions	9kHz - 30 MHz	3m	± 2.60 dB
	30 - 300 MHz	3m	± 2.61 dB
	300 - 1000 MHz	3m	± 2.59 dB
	1 - 7 GHz	3m	± 2.84 dB
	7 - 18 GHz	3m	± 2.84 dB
	18 - 26.5 GHz	3m	± 2.84 dB

Test Item	Frequency	Distance	EMC Site
AC Power-line Conducted Emissions	150kHz - 30MHz	-	± 3.34 dB
Radiated Emissions	9kHz - 30 MHz	3m	± 3.13 dB
	30 - 300 MHz	3m	± 3.14 dB
	300 - 1000 MHz	3m	± 3.12 dB
	1 - 6 GHz	3m	± 3.33 dB
	6 - 18 GHz	3m	± 3.33 dB
	18 - 26.5 GHz	3m	± 3.33 dB

2. System Test Configuration

2.1. Validation

The system was configured for testing in a typical (as a customer would normally use it).
The tests were conducted with the worst case modes as follows.

2.2. Test Operating Conditions

The tests have been carried out the following conditions.

Test Items	Operating Mode *1	Packet type *2,3	Test Channels
AC Power-line Conducted Emissions *4	BDR	DH5	2402MHz
Carrier Frequency Separation, Number of Hopping Frequencies, Time of Occupancy (Dwell Time)	BDR	DH5	Hopping ON
	EDR	3DH5	
Radiated Spurious Emissions (below 1GHz) *4	BDR	DH5	2441MHz
	EDR	3DH5	2402MHz
20dB Bandwidth, Maximum Peak Conducted Output Power, Radiated Spurious Emissions (above 1GHz)	BDR	DH5	2402MHz, 2441MHz, 2480MHz
	EDR	3DH5	
Conducted Spurious Emissions for Band Edge	BDR	DH5	2402MHz
	EDR	3DH5	

Note:

*1: Inquiry mode was not performed based on the result of pre-compliance testing.

*2: The worst packet type has been decided based on the result of maximum duty cycle and pre-compliance testing in the actual product specification.

*3: Packet type for EDR has been decided based on the result of Maximum Peak Conducted Output Power.

*4: The test was performed with the representative mode that had been found as the worst emissions while exploratory testing.

The Software for Operating Mode

Nam : labtool

Version : 2.0.0.59

Special accessories needed for connecting the EUT to achieve compliance:

Item	Manufacturer	Model No.	Serial No.	Remark
Personal Computer	lenovo	X230	38-35674	-
AC Adaptor	lenovo	42T4418	Z1ZG WG08PAWL	-

2.3. EUT Modifications

- No equipment modification to achieve compliance to the standard levels was done during the tests.
- Equipment was modified to achieve compliance to the standard level as below.

Responsible Party Signature

Typed/ Print Name :
Responsible Party :
Position :
Date :

2.4. Configuration of Tested System

Antenna-port Conducted Measurements

The equipment under test (EUT)

Symbol	Item	Manufacturer	Model No.	Serial No.
A	Communication Module	SONY	FLE01WBM	1

Support equipment for operation

Symbol	Item	Manufacturer	Model No.	Serial No.
B	JIG Board	-	-	-
C	Regulated DC Power Supply	KENWOOD	PW18-1.3AT	7030091

Type of cable

Symbol	Description	Identification (Manufacturer etc.)	Shielded YES / NO	Ferrite Core	Length (m)	Bundled
1	DC Cable	-	NO	NO	1.0	-
2	DC Cable	-	NO	NO	1.0	-
3	AC Cable	-	NO	NO	2.0	-

System configuration

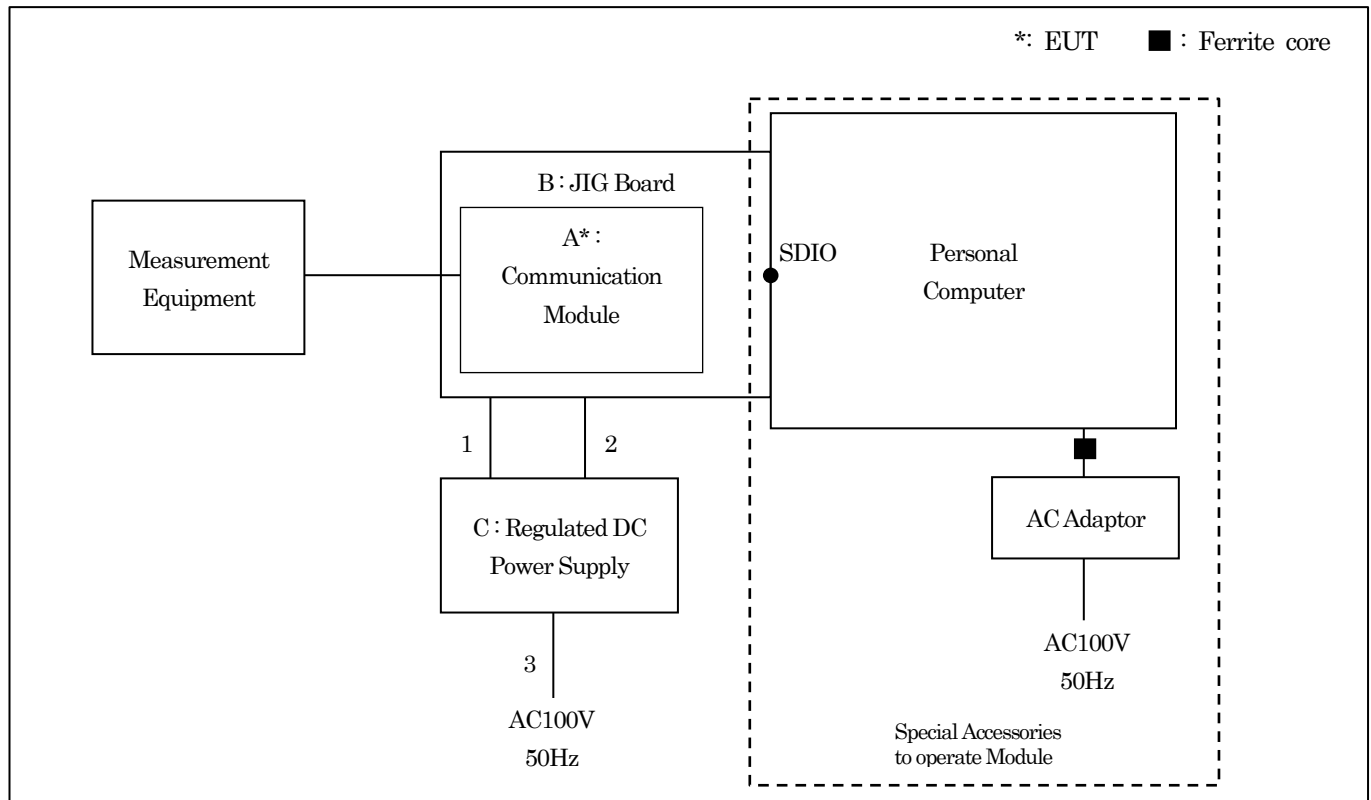

AC Power-line Conducted Emissions

The equipment under test (EUT)

Symbol	Item	Manufacturer	Model No.	Serial No.
A-1	Communication Module	SONY	FLE01WBM	1
A-2	Antenna	SONY	-	-

Support equipment for operation

Symbol	Item	Manufacturer	Model No.	Serial No.
B	JIG Board	-	-	-
C	Regulated DC Power Supply	KENWOOD	PW18-1.3AT	7030091

Type of cable

Symbol	Description	Identification (Manufacturer etc.)	Shielded YES / NO	Ferrite Core	Length (m)	Bundled
1	DC Cable	-	No	No	1.8	-
2	DC Cable	-	No	No	2.0	-
3	AC Cable	-	No	No	2.0	Bundled
4	Antenna Cable	-	No	No	0.5	-

System configuration

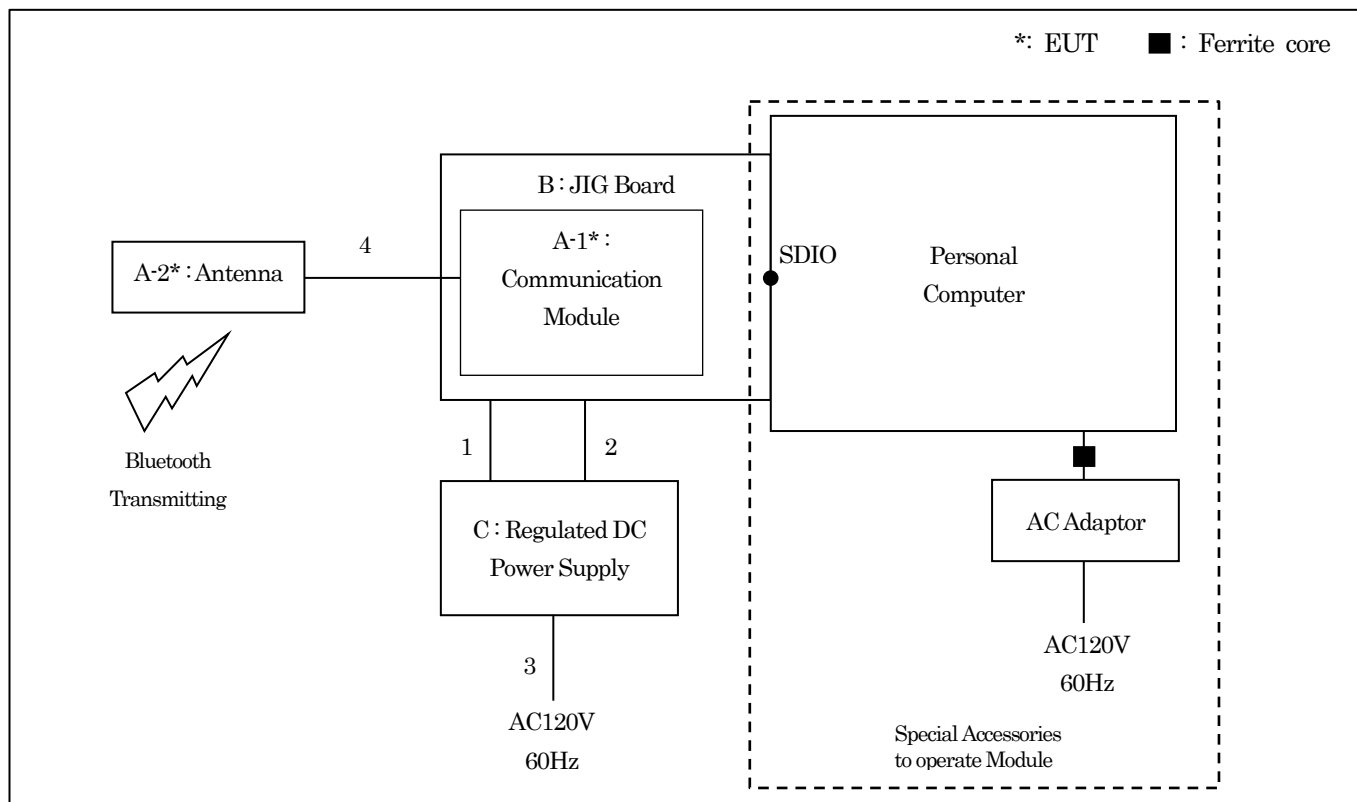

Radiated Spurious Emissions Measurement

The equipment under test (EUT)

Symbol	Item	Manufacturer	Model No.	Serial No.
A-1	Communication Module	SONY	FLE01WBM	1
A-2	Antenna	SONY	-	-

Support equipment for operation

Symbol	Item	Manufacturer	Model No.	Serial No.
B	JIG Board	-	-	-
C	Regulated DC Power Supply	KENWOOD	PWR18-2P	6120013

Type of cable

Symbol	Description	Identification (Manufacturer etc.)	Shielded YES / NO	Ferrite Core	Length (m)	Bundled
1	DC Cable	-	No	No	1.8	-
2	DC Cable	-	No	No	2.0	-
3	AC Cable	-	No	No	2.0	-
4	Antenna Cable	-	No	No	0.5	-

System configuration

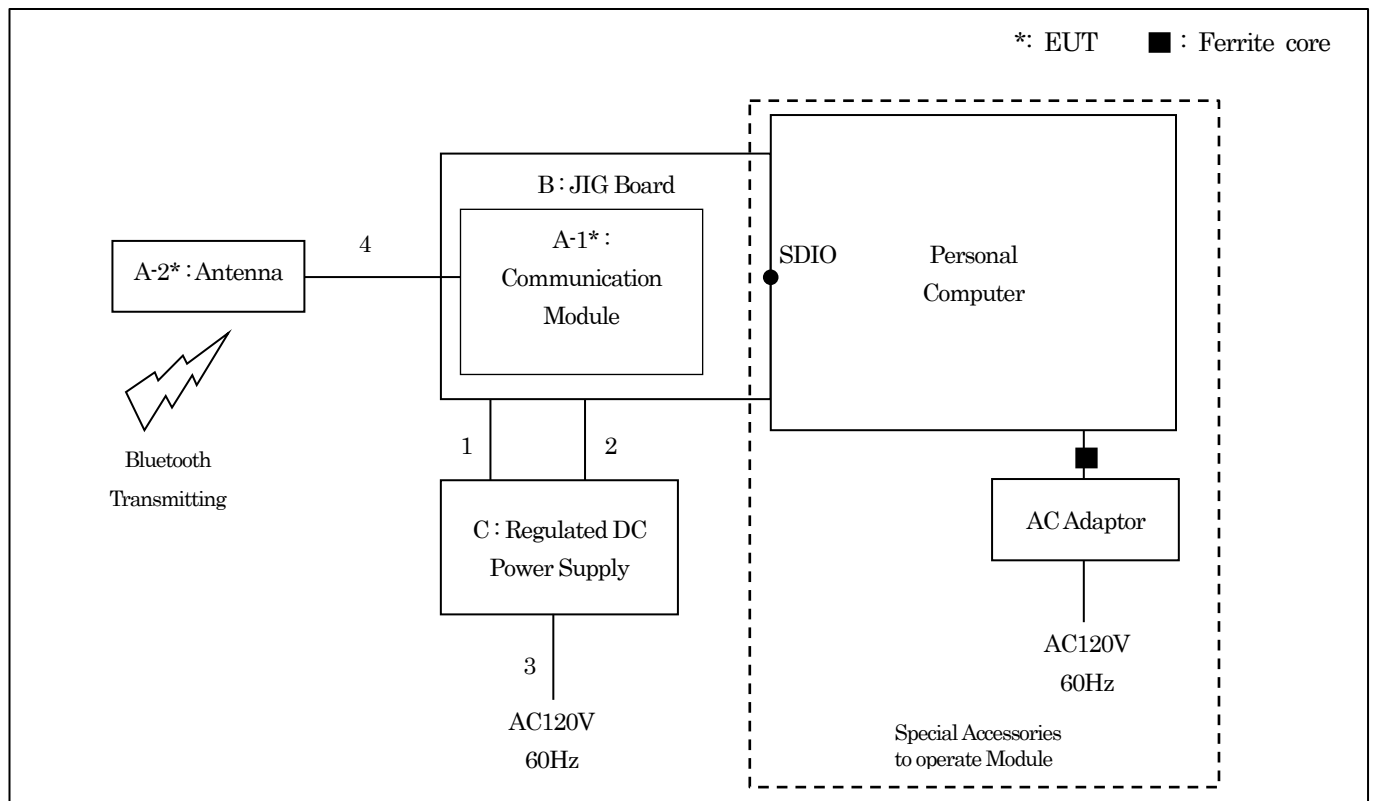

3. Test Data

3.1. AC Power-line Conducted Emissions

1) Date of measurement : July 11, 2018
 [BDR(DH5)/2402MHZ]

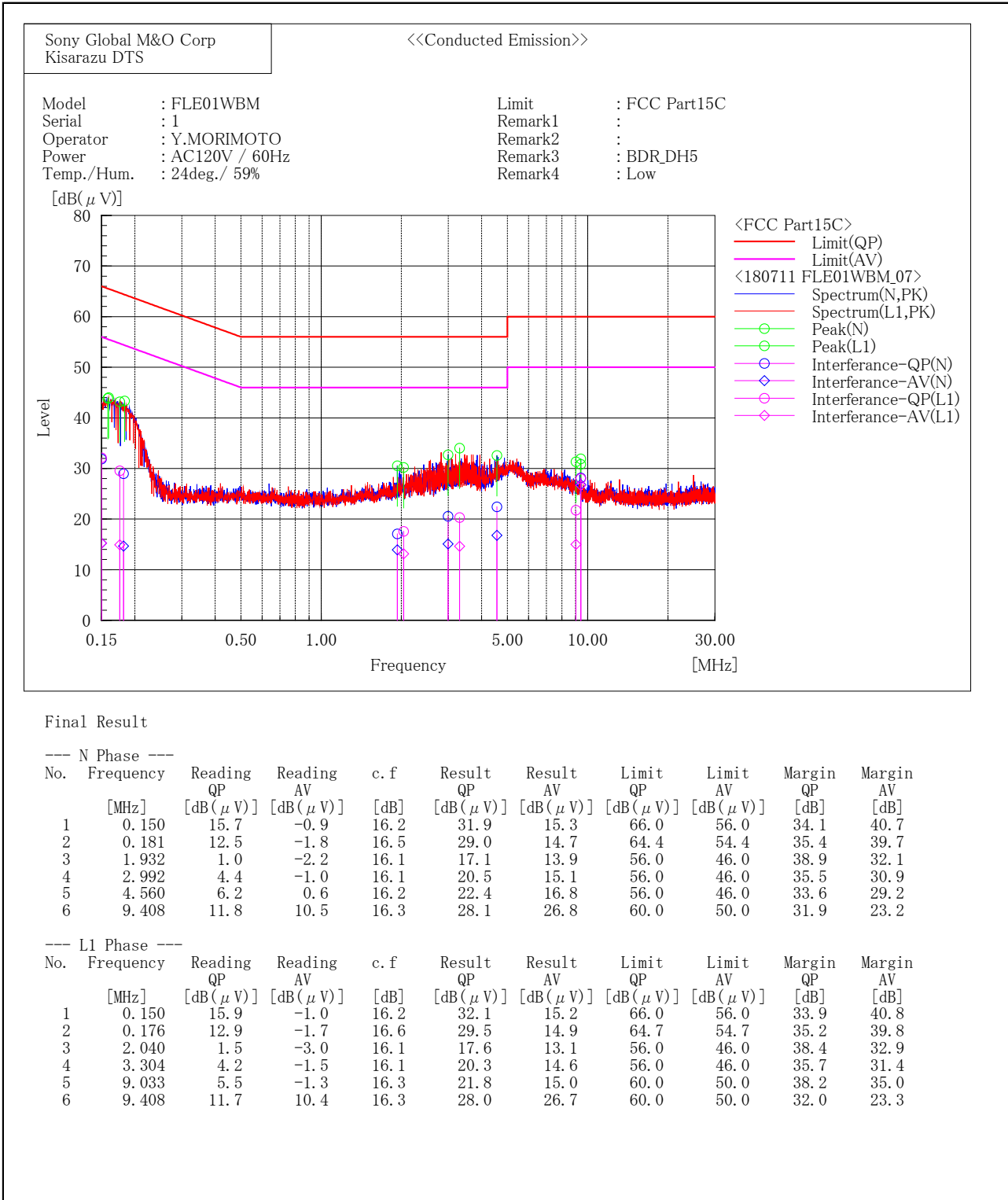

3.2. 20dB Bandwidth

- 1) Ambient temperature : 24.9 deg.C
- 2) Relative humidity : 63.6 %
- 3) Date of measurement : May 31, 2018
- 4) Measured by : M.KOUGA
- 5) Operating mode : Transmitting mode

Mode		Channel [MHz]	Result [MHz]	Limit [MHz]
BDR	DH5	2402	0.985	-
		2441	0.986	-
		2480	0.986	-
EDR	3DH5	2402	1.295	-
		2441	1.294	-
		2480	1.296	-

[BDR / 2402MHz]



[BDR / 2441MHz]



[BDR / 2480MHz]



[EDR / 2402MHz]



[EDR / 2441MHz]

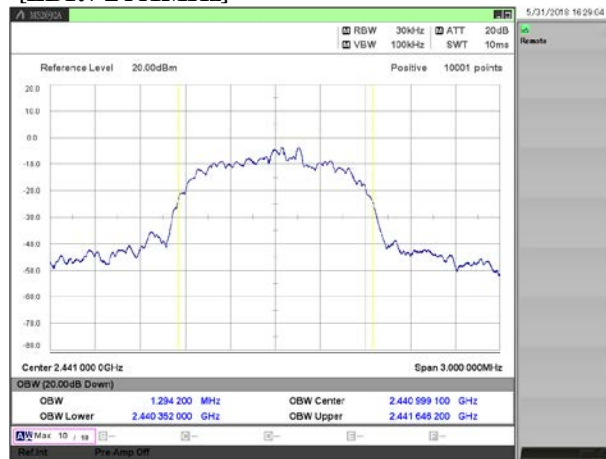

[EDR / 2480MHz]

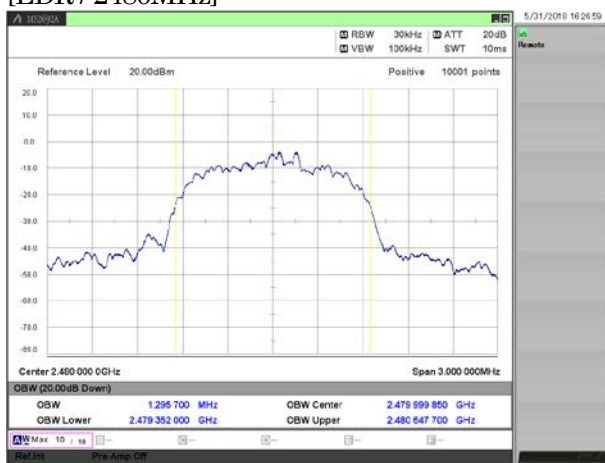

3.3. Carrier Frequency Separation

- 1) Ambient temperature : 24.9 deg.C
- 2) Relative humidity : 63.6 %
- 3) Date of measurement : May 31, 2018 / August 23, 2018
- 4) Measured by : M.KOUGA
- 5) Operating mode : Transmitting mode

Mode		Reading [kHz]	Limit [kHz]
BDR	DH5	984.9	≧ 657.4
EDR	3DH5	998.7	≧ 863.8

[BDR]



[EDR]

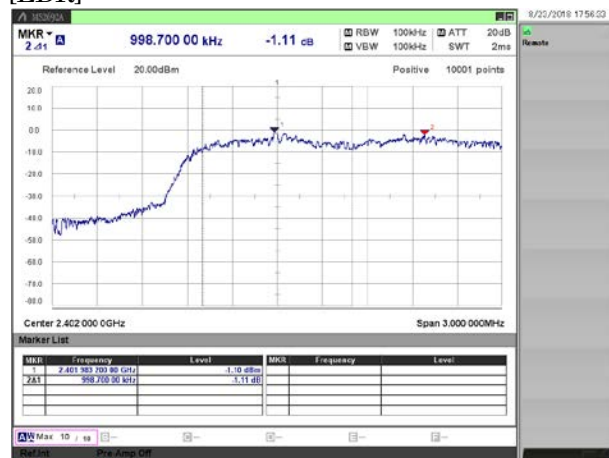

3.4. Number of Hopping Frequencies

- 1) Ambient temperature : 24.9 deg.C
- 2) Relative humidity : 63.6 %
- 3) Date of measurement : May 31, 2018
- 4) Measured by : M.KOUGA
- 5) Operating mode : Transmitting mode

Mode		Number [channel]	Limit [channel]
BDR	DH5	79	≥ 15
EDR	3DH5	79	≥ 15

[BDR]



[EDR]

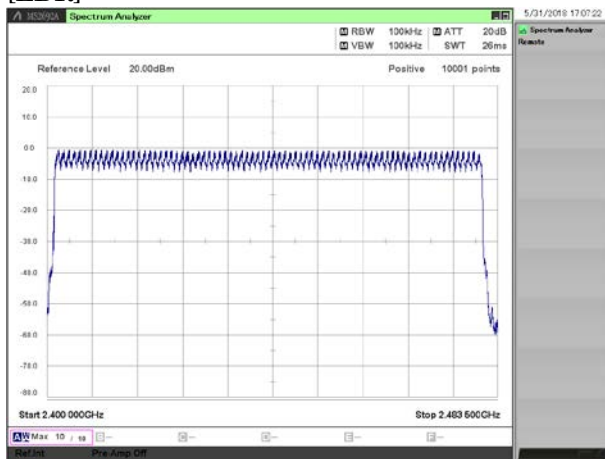

3.5. Time of Occupancy (Dwell Time)

- 1) Ambient temperature : 24.9 deg.C
- 2) Relative humidity : 63.6 %
- 3) Date of measurement : May 31, 2018
- 4) Measured by : M.KOUGA
- 5) Operating mode : Transmitting mode

Mode		Channel [MHz]	Dwell Time [msec]	Cycle [time]	Result [msec]	Limit [msec]
BDR	DH5	2402	2.88	16.7	304.4	≤ 400.0
		2441	2.88	16.8	306.2	≤ 400.0
		2480	2.88	16.7	304.4	≤ 400.0
EDR	3DH5	2402	2.88	16.8	306.2	≤ 400.0
		2441	2.88	16.7	304.3	≤ 400.0
		2480	2.88	16.6	302.5	≤ 400.0

[BDR / 2402MHz]

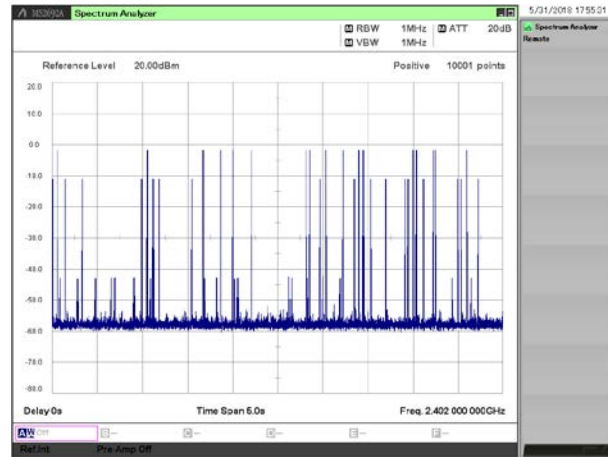
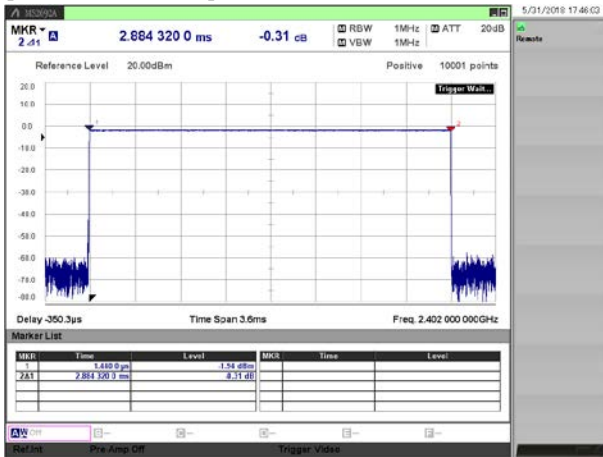

[BDR / 2441MHz]

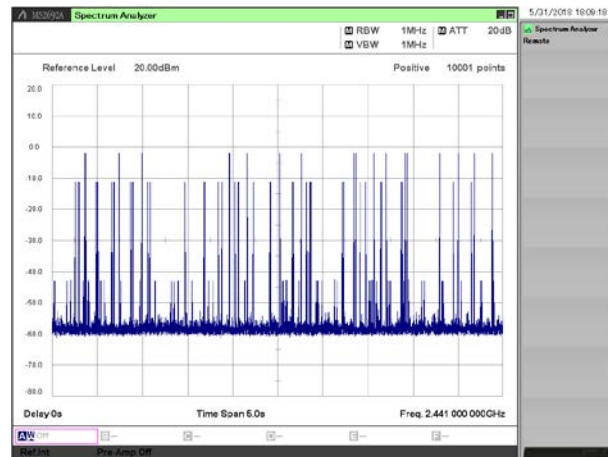
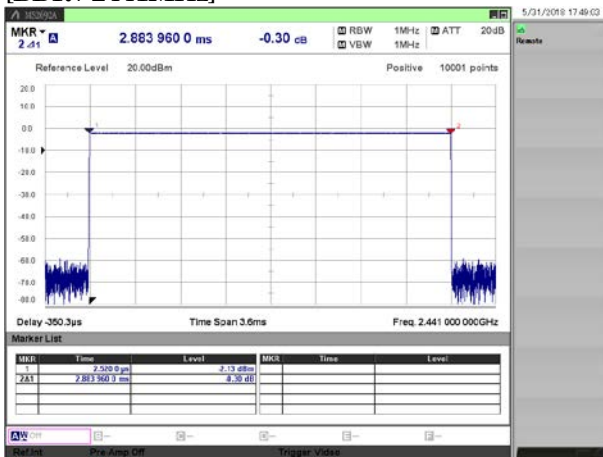

[BDR / 2480MHz]

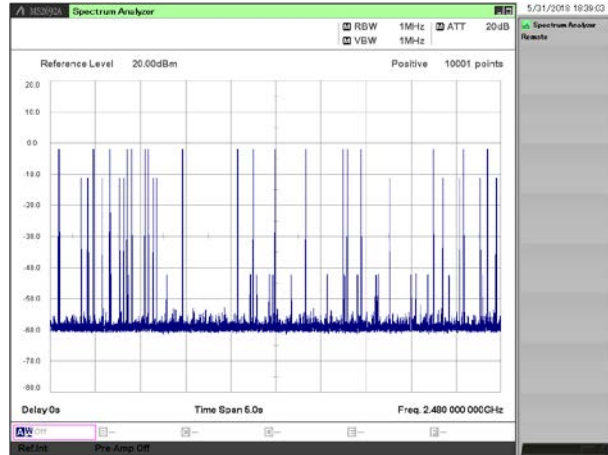
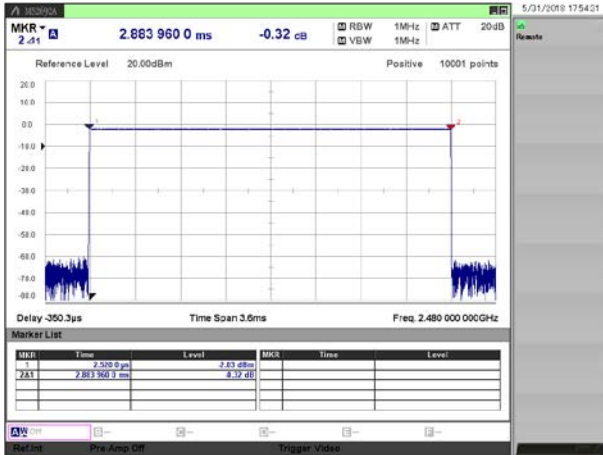

[EDR / 2402MHz]

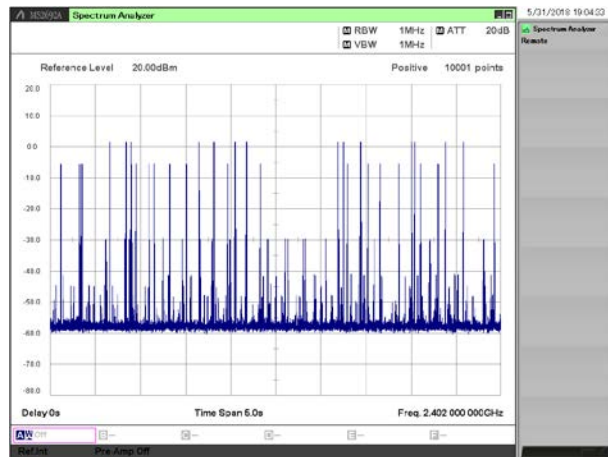
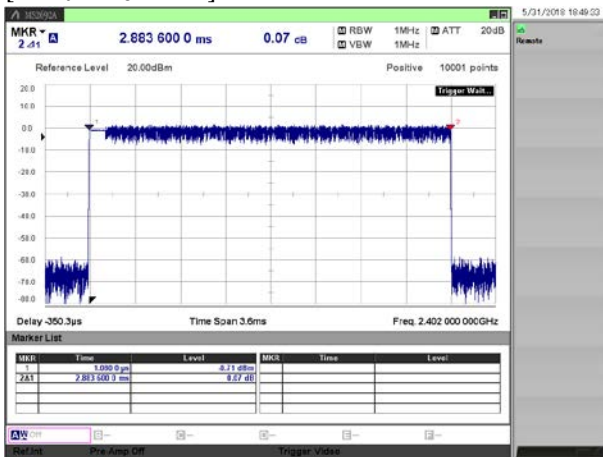

[EDR / 2441MHz]

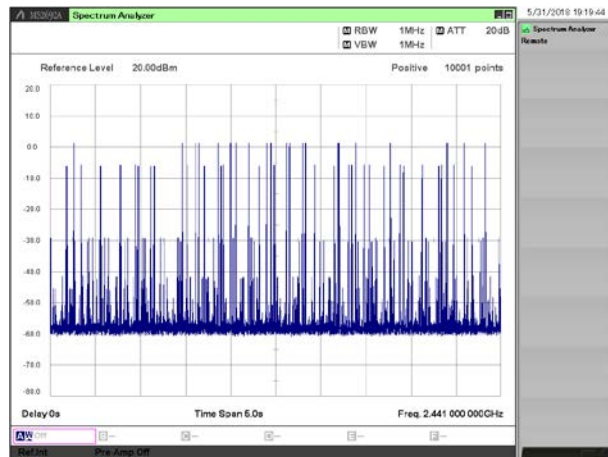
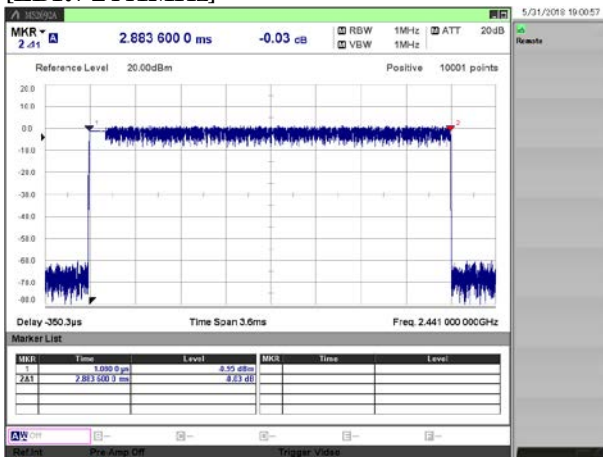

[EDR / 2480MHz]

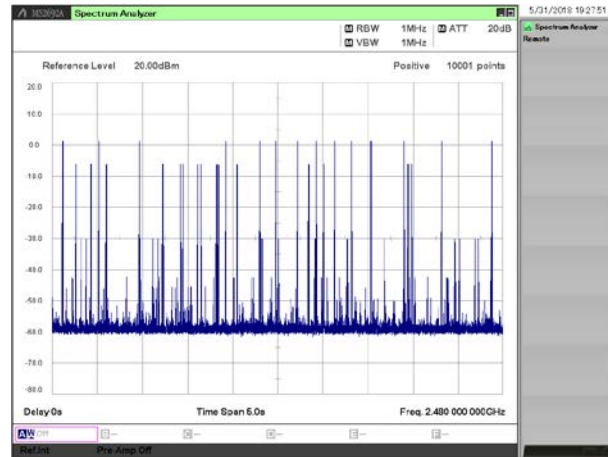
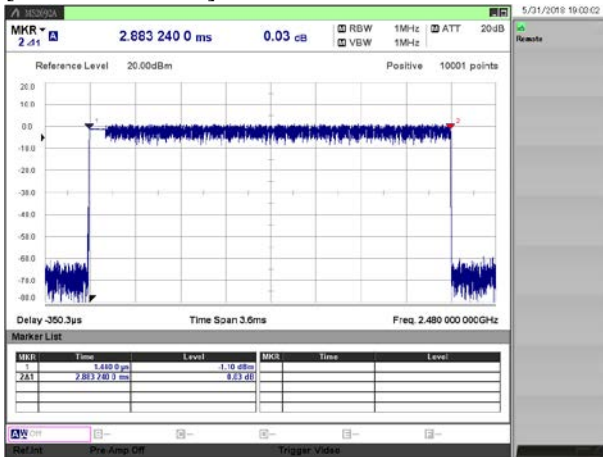

3.6. Maximum Peak Conducted Output Power

- 1) Ambient temperature : 24.9 deg.C
- 2) Relative humidity : 63.6 %
- 3) Date of measurement : May 31, 2018
- 4) Measured by : M.KOUGA
- 5) Operating mode : Transmitting mode

Peak Conducted Output Power

Mode		Channel [MHz]	Reading(PK) [dBm]	C.F. [dB]	Result(PK) [dBm]	Result(PK) [W]	Limit [dBm]	Limit [W]	Margin [dB]
BDR	DH5	2402	-1.53	0.87	-0.66	0.00086	30.0	1.0	30.66
		2441	-1.57	0.87	-0.70	0.00085	30.0	1.0	30.70
		2480	-1.65	0.87	-0.78	0.00084	30.0	1.0	30.78
EDR	2DH5	2402	2.29	0.87	3.16	0.00207	30.0	1.0	26.84
		2441	2.21	0.87	3.08	0.00203	30.0	1.0	26.92
		2480	1.97	0.87	2.84	0.00192	30.0	1.0	27.16
	3DH5	2402	2.60	0.87	3.47	0.00222	30.0	1.0	26.53
		2441	2.49	0.87	3.36	0.00217	30.0	1.0	26.64
		2480	2.30	0.87	3.17	0.00207	30.0	1.0	26.83

Average Conducted Output Power (for SAR measurement)

Mode		Channel [MHz]	Reading(AV) [dBm]	C.F. [dB]	Duty Factor [dB]	Result(AV) [dBm]	Result(AV) [W]
BDR	DH5	2402	-2.74	0.87	1.14	-0.73	0.00085
		2441	-2.78	0.87	1.14	-0.77	0.00084
		2480	-2.85	0.87	1.14	-0.84	0.00082
EDR	2DH5	2402	-1.61	0.87	1.14	0.40	0.00110
		2441	-1.74	0.87	1.14	0.27	0.00106
		2480	-1.98	0.87	1.14	0.03	0.00101
	3DH5	2402	-1.61	0.87	1.14	0.40	0.00110
		2441	-1.75	0.87	1.14	0.26	0.00106
		2480	-1.98	0.87	1.14	0.03	0.00101

Duty Cycle check

Mode		Channel [MHz]	T(on+off) [msec]	T(on) [msec]	Duty Cycle [%]
BDR	DH1	2441	1.250	0.381	30.45
	DH3	2441	2.500	1.637	65.46
	DH5	2441	3.750	2.884	76.91
EDR	2DH1	2441	1.250	0.383	30.67
	2DH3	2441	2.500	1.635	65.40
	2DH5	2441	3.750	2.882	76.85
	3DH1	2441	1.250	0.382	30.58
	3DH3	2441	2.500	1.633	65.30
	3DH5	2441	3.750	2.882	76.85

3.7. Radiated Spurious Emissions

1) Date of measurement

9kHz - 30MHz : June 04, 2018 (all mode)
 30MHz - 1000MHz : July 08, 2018 (all mode)
 1GHz - 6GHz : July 18, 2018 (all mode)
 6GHz - 18GHz : June 02, 2018 (all mode)
 18GHz - 24.835GHz : June 03, 2018 (all mode)

9 kHz - 30 MHz

[EDR(3DH5)/2402MHz]

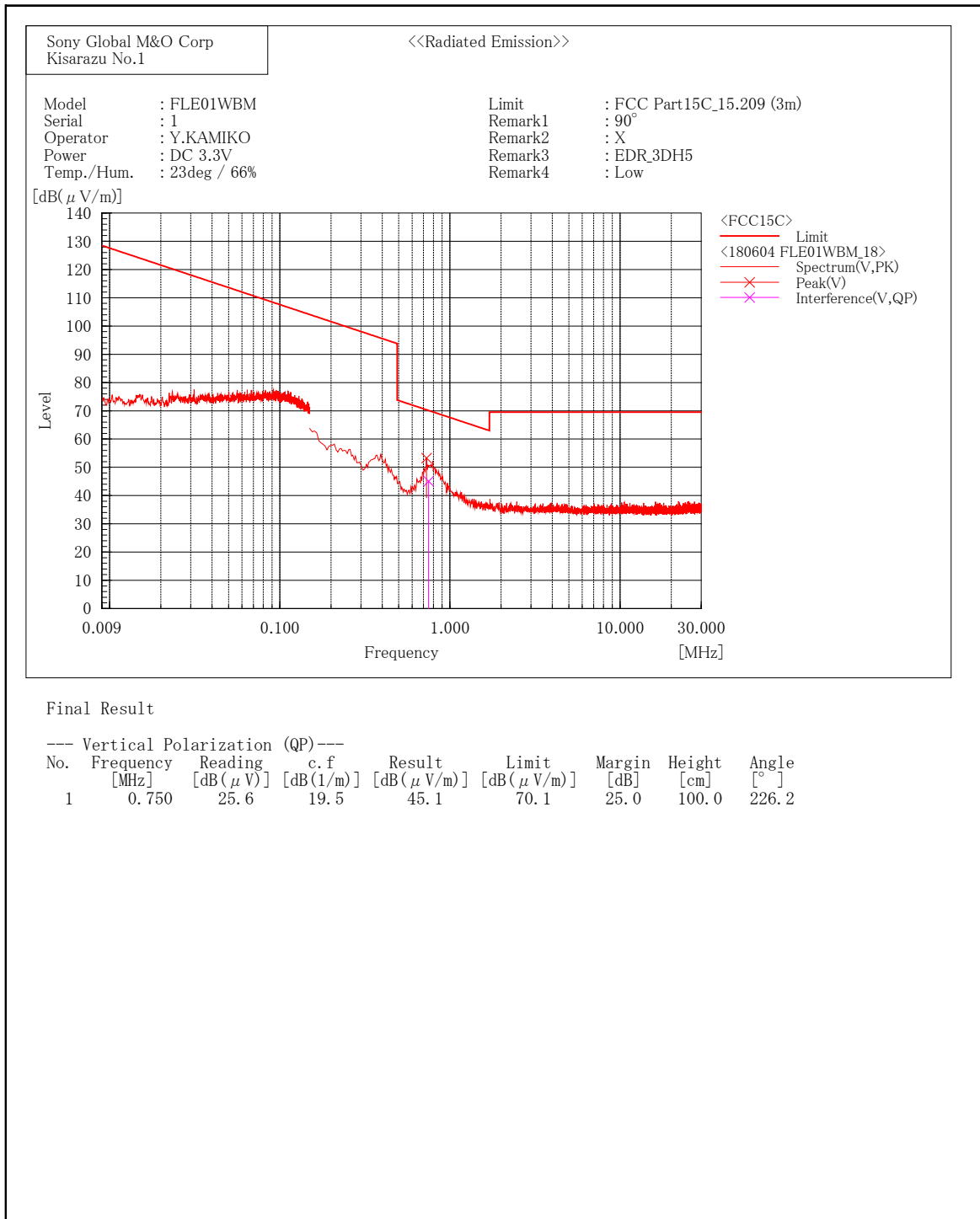

30 MHz - 1000 MHz

[BDR(DH5)/2441MHz]

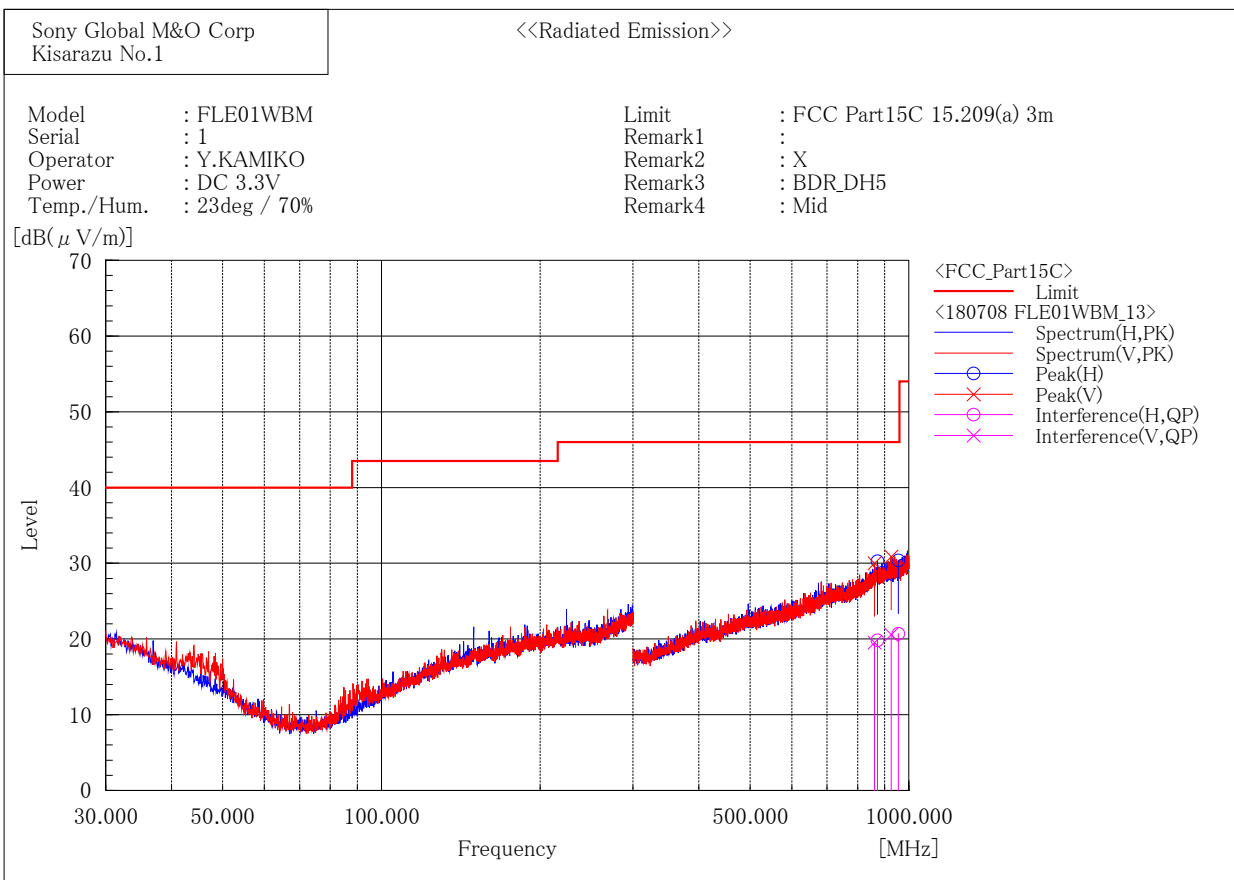

1GHz - 6 GHz

[BDR(DH5)/2402MHz]

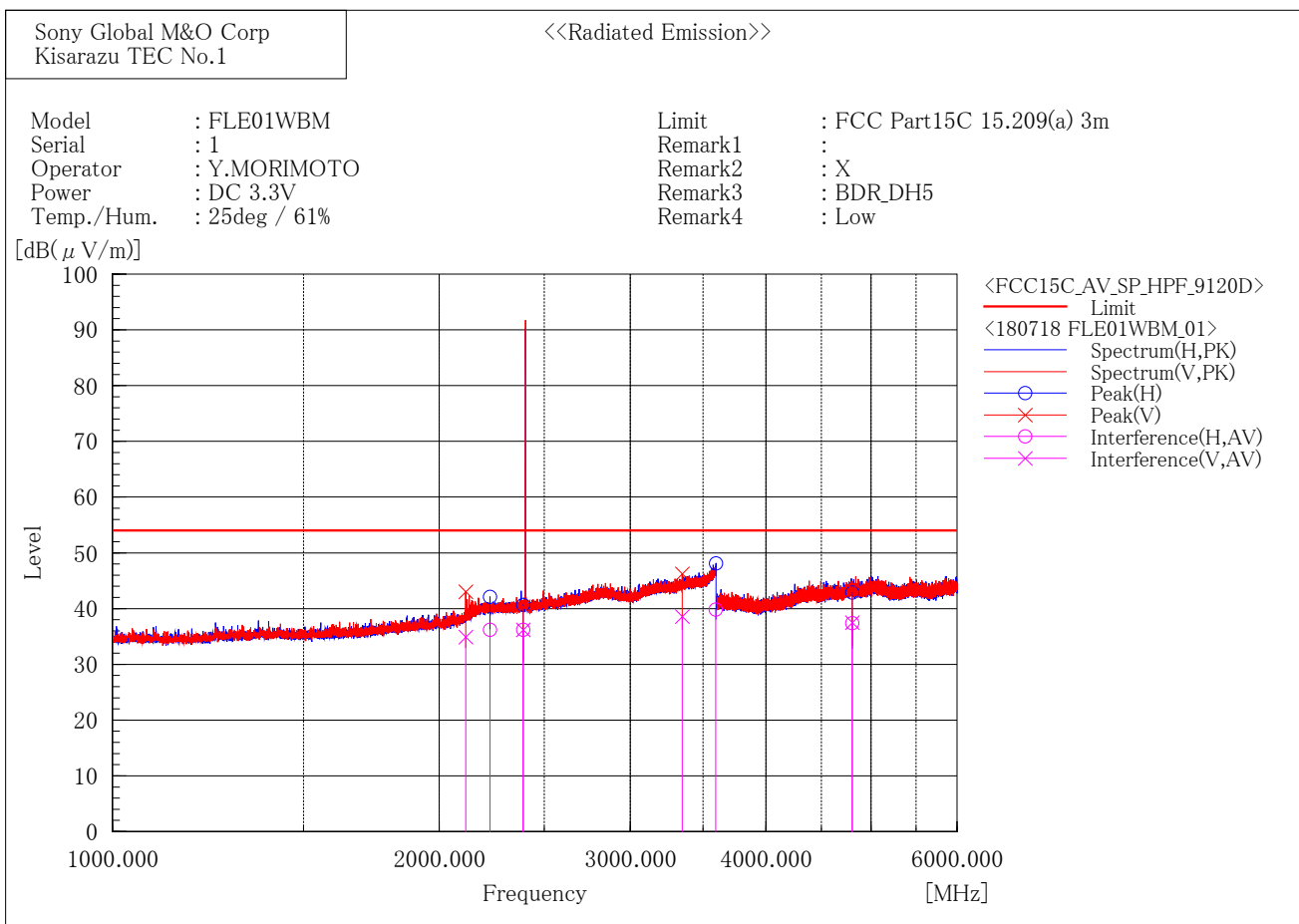

Final Result

--- Horizontal Polarization (AV)---

No.	Frequency [MHz]	Reading [dB(μV)]	c. f [dB(1/m)]	Result [dB(μV/m)]	Limit [dB(μV/m)]	Margin [dB]	Height [cm]	Angle [°]
1	2228.322	34.6	1.6	36.2	54.0	17.8	218.9	72.2
2	2390.000	34.7	1.5	36.2	54.0	17.8	254.6	54.5
3	3596.485	34.1	5.7	39.8	54.0	14.2	334.3	225.2
4	4803.862	26.4	11.0	37.4	54.0	16.6	244.0	70.2

--- Vertical Polarization (AV)---

No.	Frequency [MHz]	Reading [dB(μV)]	c. f [dB(1/m)]	Result [dB(μV/m)]	Limit [dB(μV/m)]	Margin [dB]	Height [cm]	Angle [°]
1	2116.473	34.6	0.3	34.9	54.0	19.1	173.4	355.3
2	2390.000	34.7	1.5	36.2	54.0	17.8	201.6	282.7
3	3349.340	34.1	4.5	38.6	54.0	15.4	158.4	123.6
4	4803.959	26.5	11.0	37.5	54.0	16.5	219.3	35.9

[BDR(DH5)/2441MHz]

Sony Global M&O Corp
Kisarazu TEC No.1

<<Radiated Emission>>

Model	: FLE01WBM	Limit	: FCC Part15C 15.209(a) 3m
Serial	: 1	Remark1	:
Operator	: Y.MORIMOTO	Remark2	: X
Power	: DC 3.3V	Remark3	: BDR_DH5
Temp./Hum.	: 25deg / 61%	Remark4	: Mid

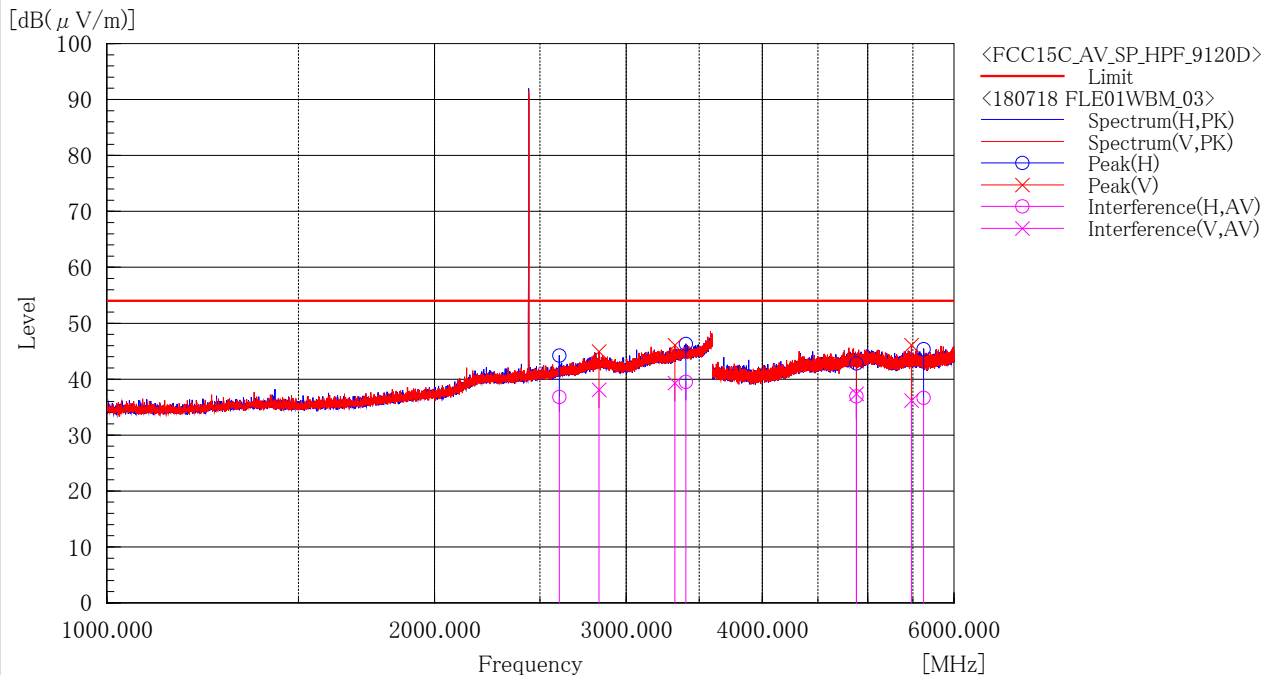

Final Result

--- Horizontal Polarization (AV)---

No.	Frequency [MHz]	Reading [dB(μV)]	c. f [dB(1/m)]	Result [dB(μV/m)]	Limit [dB(μV/m)]	Margin [dB]	Height [cm]	Angle [°]
1	2603.572	34.7	2.1	36.8	54.0	17.2	429.9	359.1
2	3403.713	34.9	4.6	39.5	54.0	14.5	381.4	320.5
3	4882.065	26.2	10.7	36.9	54.0	17.1	341.3	313.8
4	5627.049	25.5	11.2	36.7	54.0	17.3	109.5	266.2

--- Vertical Polarization (AV)---

No.	Frequency [MHz]	Reading [dB(μV)]	c. f [dB(1/m)]	Result [dB(μV/m)]	Limit [dB(μV/m)]	Margin [dB]	Height [cm]	Angle [°]
1	2831.518	34.7	3.4	38.1	54.0	15.9	301.0	98.4
2	3325.143	34.9	4.4	39.3	54.0	14.7	386.1	1.4
3	4882.354	26.7	10.7	37.4	54.0	16.6	180.7	31.9
4	5482.786	25.0	11.2	36.2	54.0	17.8	173.9	327.4

[BDR(DH5)/2480MHz]

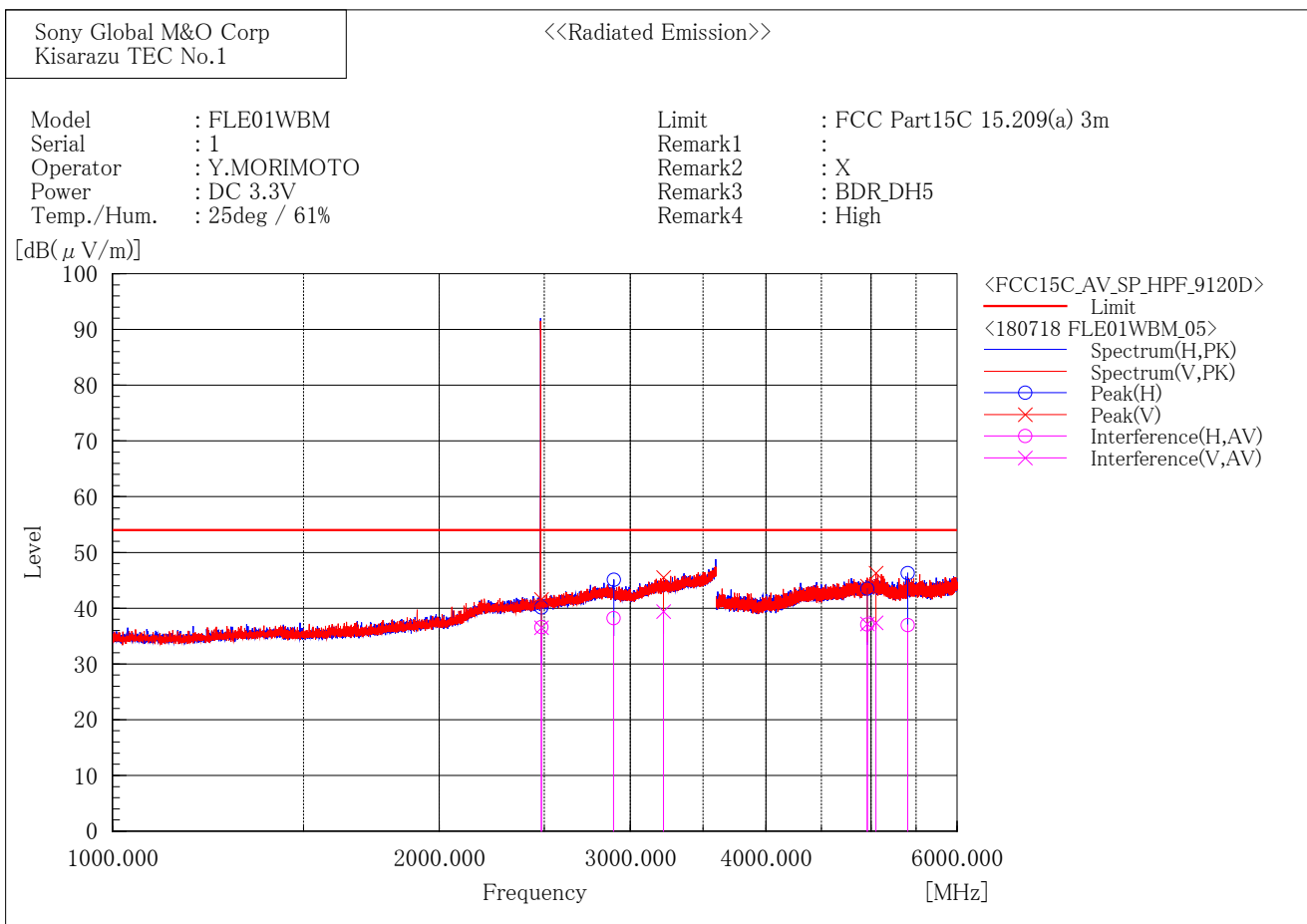

Final Result

--- Horizontal Polarization (AV)---

No.	Frequency [MHz]	Reading [dB(μV)]	c. f [dB(1/m)]	Result [dB(μV/m)]	Limit [dB(μV/m)]	Margin [dB]	Height [cm]	Angle [°]
1	2483.500	34.7	1.9	36.6	54.0	17.4	176.1	91.0
2	2895.514	34.6	3.6	38.2	54.0	15.8	100.0	5.4
3	4960.085	26.1	11.0	37.1	54.0	16.9	111.7	310.0
4	5404.469	25.7	11.3	37.0	54.0	17.0	170.8	66.0

--- Vertical Polarization (AV)---

No.	Frequency [MHz]	Reading [dB(μV)]	c. f [dB(1/m)]	Result [dB(μV/m)]	Limit [dB(μV/m)]	Margin [dB]	Height [cm]	Angle [°]
1	2483.500	34.6	1.9	36.5	54.0	17.6	432.0	325.7
2	3218.798	34.9	4.5	39.4	54.0	14.6	357.0	152.1
3	4959.782	26.2	11.0	37.2	54.0	16.8	178.6	161.1
4	5051.265	25.9	11.5	37.4	54.0	16.6	129.6	310.9

[BDR(DH5)/2402MHz]

Sony Global M&O Corp
Kisarazu TEC No.1

<<Radiated Emission>>

Model : FLE01WBM
Serial : 1
Operator : Y.MORIMOTO
Power : DC 3.3V
Temp./Hum. : 25deg / 61%

Limit : FCC Part15C 15.209(a) 3m
Remark1 :
Remark2 : X
Remark3 : BDR_DH5
Remark4 : Low

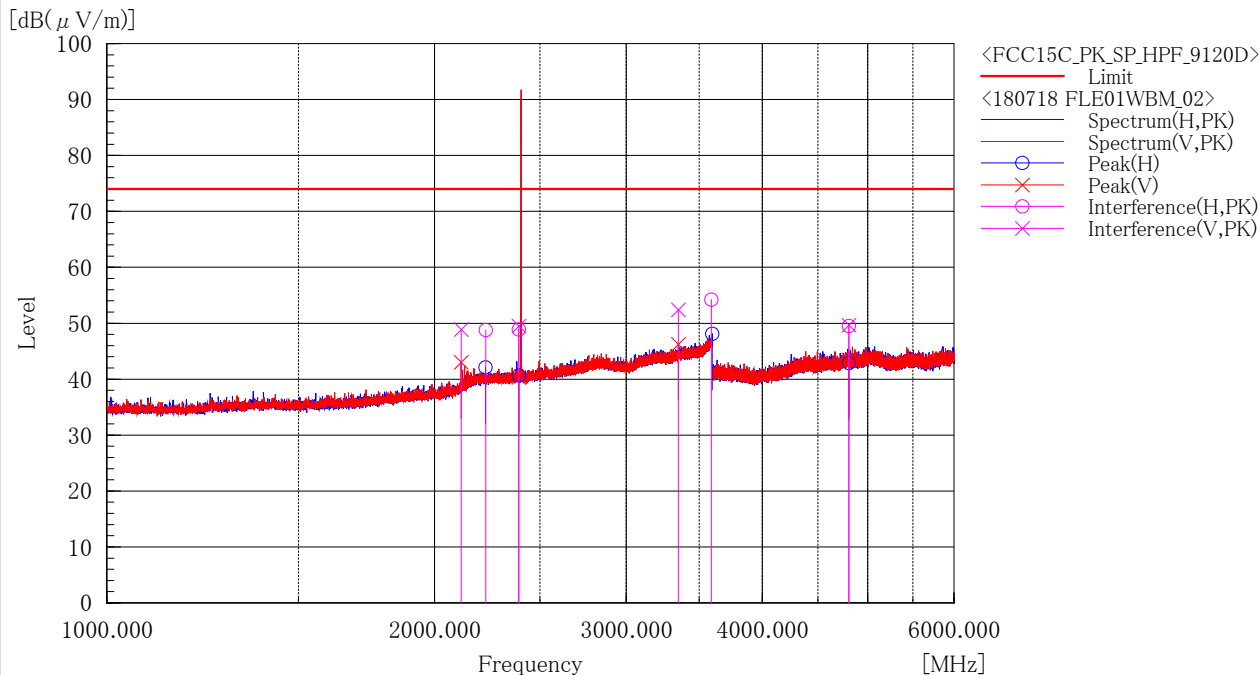

Final Result

--- Horizontal Polarization (PK)---

No.	Frequency [MHz]	Reading [dB(μV)]	c. f [dB(1/m)]	Result [dB(μV/m)]	Limit [dB(μV/m)]	Margin [dB]	Height [cm]	Angle [°]
1	2229.160	47.2	1.6	48.8	74.0	25.2	218.9	70.4
2	2390.000	47.4	1.5	48.9	74.0	25.1	254.6	56.4
3	3592.320	48.5	5.7	54.2	74.0	19.8	334.3	223.4
4	4804.380	38.5	11.0	49.5	74.0	24.5	244.0	70.2

--- Vertical Polarization (PK)---

No.	Frequency [MHz]	Reading [dB(μV)]	c. f [dB(1/m)]	Result [dB(μV/m)]	Limit [dB(μV/m)]	Margin [dB]	Height [cm]	Angle [°]
1	2116.328	48.6	0.3	48.9	74.0	25.1	173.4	357.4
2	2390.000	48.0	1.5	49.5	74.0	24.5	201.6	284.8
3	3348.770	47.9	4.5	52.4	74.0	21.6	158.4	125.7
4	4804.392	38.7	11.0	49.7	74.0	24.3	219.3	37.9

[BDR(DH5)/2441MHz]

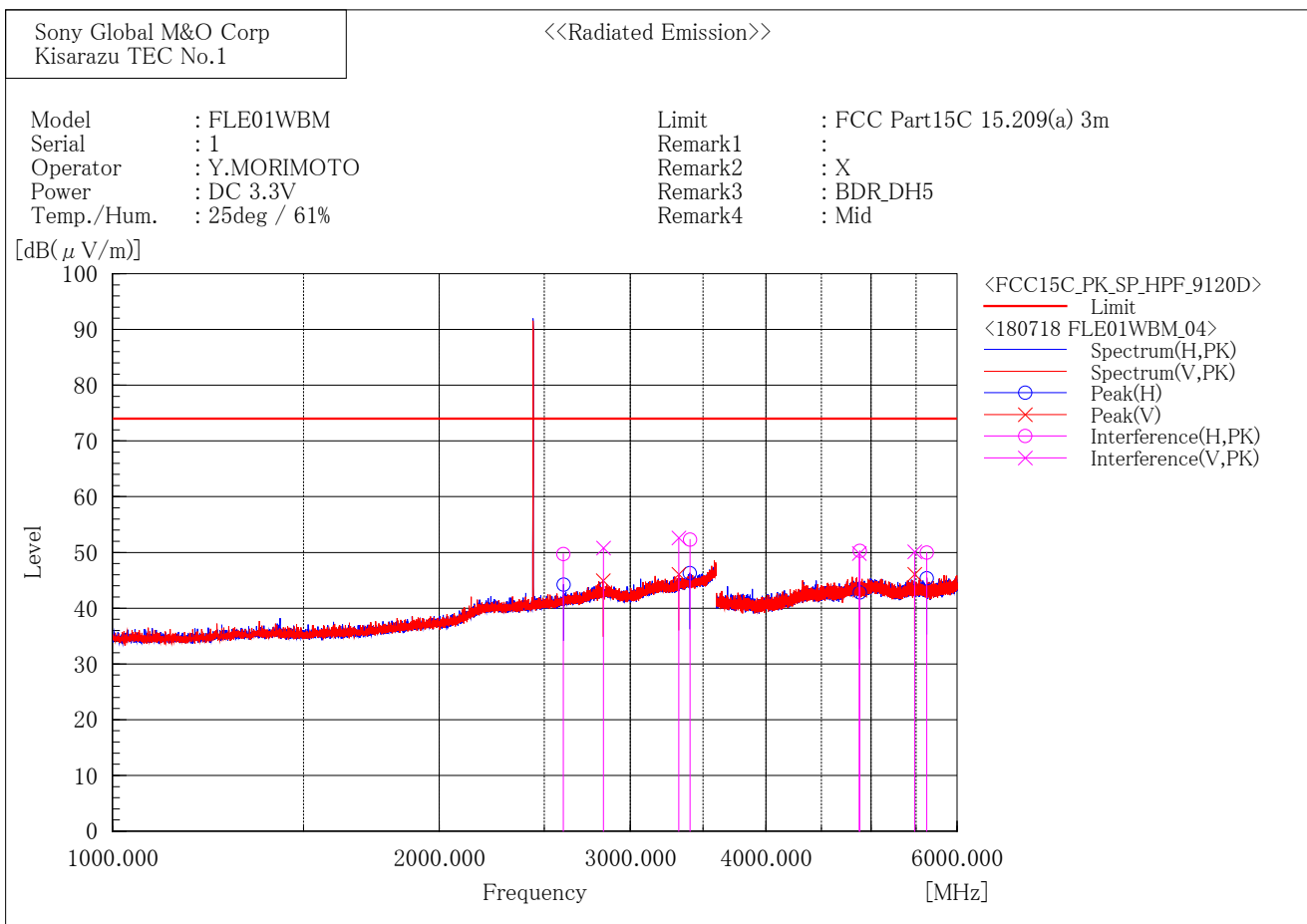

Final Result

--- Horizontal Polarization (PK)---

No.	Frequency [MHz]	Reading [dB(μV)]	c. f [dB(1/m)]	Result [dB(μV/m)]	Limit [dB(μV/m)]	Margin [dB]	Height [cm]	Angle [°]
1	2603.248	47.6	2.1	49.7	74.0	24.3	429.9	359.1
2	3404.524	47.7	4.6	52.3	74.0	21.7	381.4	320.4
3	4881.844	39.6	10.7	50.3	74.0	23.7	381.4	320.4
4	5627.487	38.8	11.2	50.0	74.0	24.0	381.4	320.4

--- Vertical Polarization (PK)---

No.	Frequency [MHz]	Reading [dB(μV)]	c. f [dB(1/m)]	Result [dB(μV/m)]	Limit [dB(μV/m)]	Margin [dB]	Height [cm]	Angle [°]
1	2833.519	47.4	3.4	50.8	74.0	23.2	301.0	94.4
2	3324.180	48.2	4.4	52.6	74.0	21.4	386.1	3.3
3	4874.825	39.1	10.7	49.8	74.0	24.2	180.7	29.8
4	5483.647	38.9	11.2	50.1	74.0	23.9	173.9	327.4

[BDR(DH5)/2480MHz]

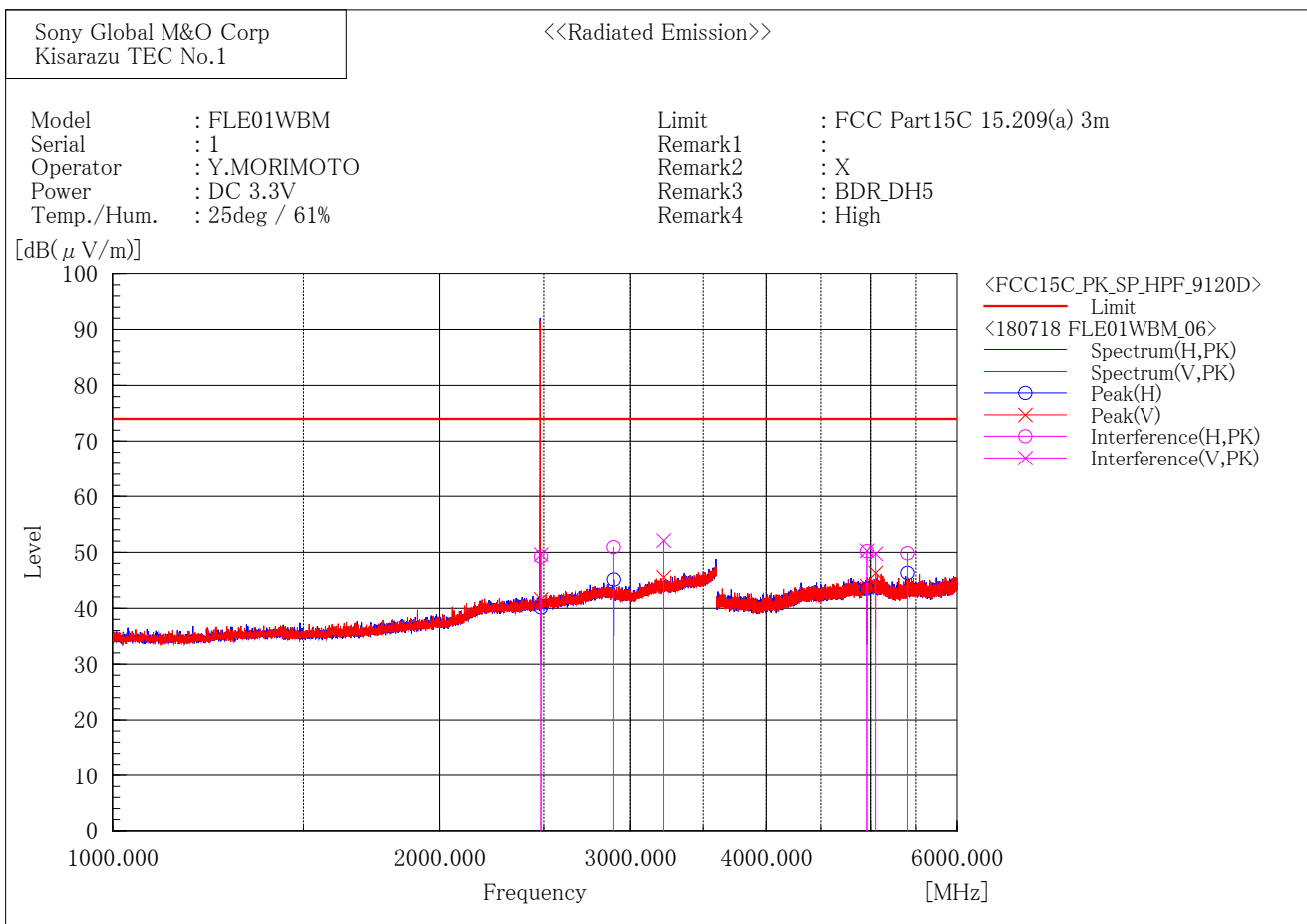

Final Result

--- Horizontal Polarization (PK)---

No.	Frequency [MHz]	Reading [dB(μV)]	c. f [dB(1/m)]	Result [dB(μV/m)]	Limit [dB(μV/m)]	Margin [dB]	Height [cm]	Angle [°]
1	2483.500	47.3	1.9	49.2	74.0	24.8	182.2	118.0
2	2894.908	47.3	3.6	50.9	74.0	23.1	100.0	7.4
3	4959.960	39.2	11.0	50.2	74.0	23.8	111.7	312.1
4	5404.129	38.5	11.3	49.8	74.0	24.2	170.8	64.0

--- Vertical Polarization (PK)---

No.	Frequency [MHz]	Reading [dB(μV)]	c. f [dB(1/m)]	Result [dB(μV/m)]	Limit [dB(μV/m)]	Margin [dB]	Height [cm]	Angle [°]
1	2483.500	47.7	1.9	49.6	74.0	24.5	432.0	327.6
2	3218.850	47.6	4.5	52.1	74.0	21.9	357.0	154.2
3	4960.679	39.3	11.0	50.3	74.0	23.7	178.6	159.5
4	5051.246	38.2	11.5	49.7	74.0	24.3	129.6	309.0

[EDR(3DH5)/2402MHz]

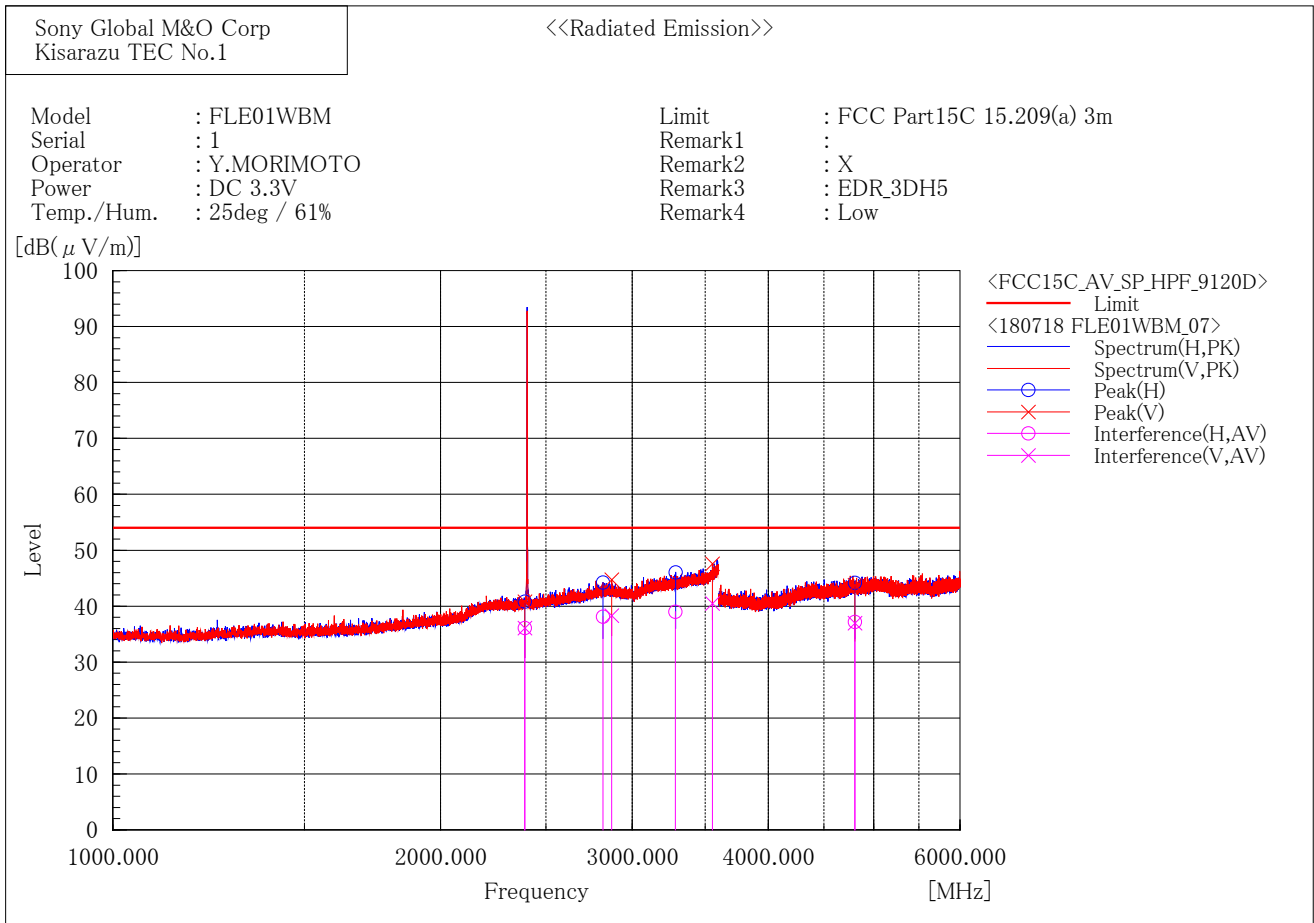

Final Result

--- Horizontal Polarization (AV)---

No.	Frequency [MHz]	Reading [dB(μV)]	c. f [dB(1/m)]	Result [dB(μV/m)]	Limit [dB(μV/m)]	Margin [dB]	Height [cm]	Angle [°]
1	2390.000	34.6	1.5	36.1	54.0	17.9	428.7	259.4
2	2820.592	34.7	3.4	38.1	54.0	15.9	221.5	142.8
3	3286.629	34.7	4.3	39.0	54.0	15.0	115.0	227.7
4	4804.226	26.2	11.0	37.2	54.0	16.8	141.8	64.4

--- Vertical Polarization (AV)---

No.	Frequency [MHz]	Reading [dB(μV)]	c. f [dB(1/m)]	Result [dB(μV/m)]	Limit [dB(μV/m)]	Margin [dB]	Height [cm]	Angle [°]
1	2390.000	34.6	1.5	36.1	54.0	17.9	196.9	309.2
2	2872.114	34.7	3.6	38.3	54.0	15.7	189.5	206.6
3	3555.242	35.0	5.5	40.5	54.0	13.5	239.1	298.0
4	4804.186	26.0	11.0	37.0	54.0	17.0	105.5	255.5

[EDR(3DH5)/2441MHz]

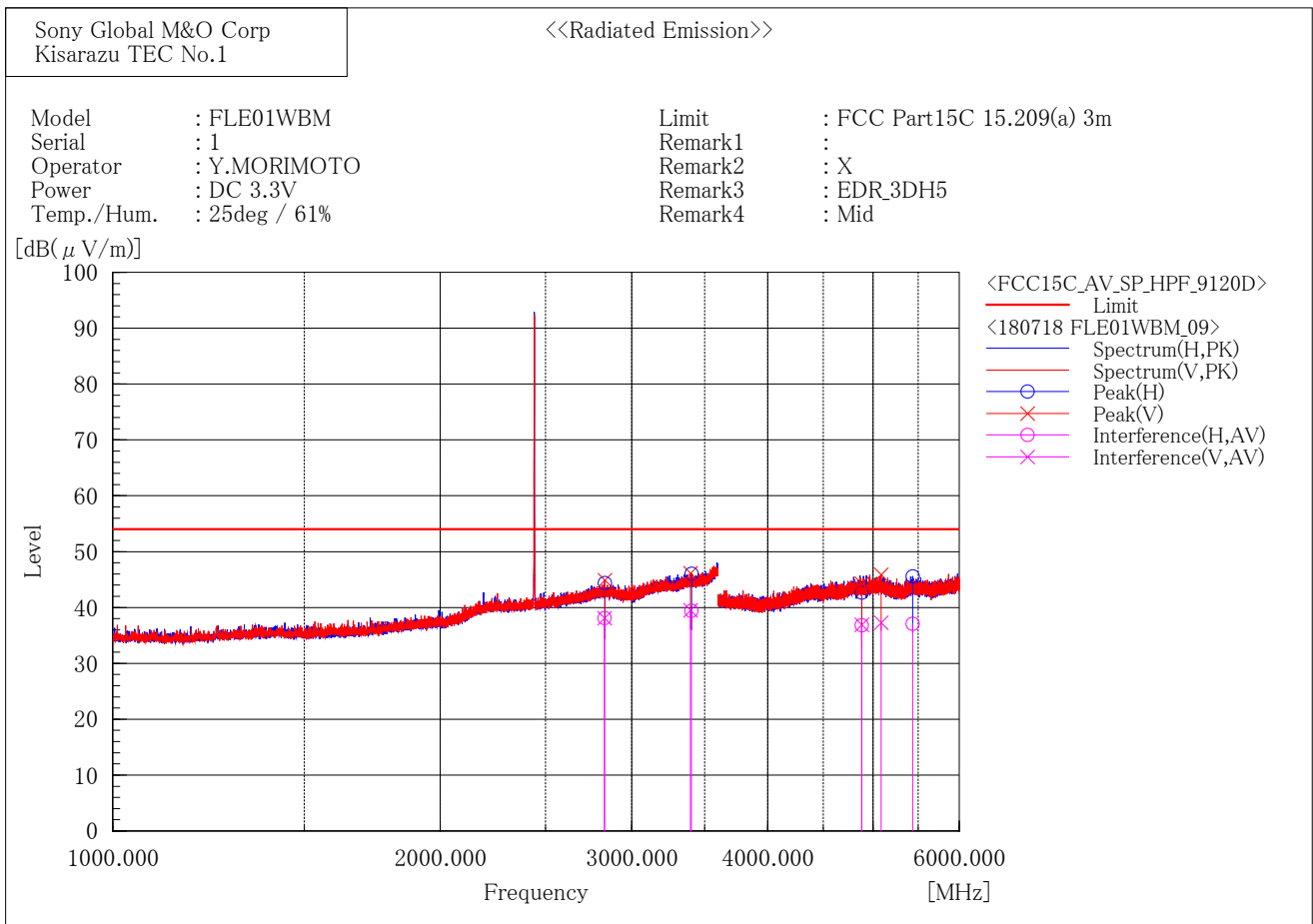

Final Result

--- Horizontal Polarization (AV)---

No.	Frequency [MHz]	Reading [dB(μV)]	c. f [dB(1/m)]	Result [dB(μV/m)]	Limit [dB(μV/m)]	Margin [dB]	Height [cm]	Angle [°]
1	2832.372	34.7	3.4	38.1	54.0	15.9	431.0	212.8
2	3403.277	34.8	4.6	39.4	54.0	14.6	122.5	93.7
3	4881.509	26.1	10.7	36.8	54.0	17.2	205.8	214.3
4	5437.061	25.8	11.3	37.1	54.0	16.9	105.6	208.4

--- Vertical Polarization (AV)---

No.	Frequency [MHz]	Reading [dB(μV)]	c. f [dB(1/m)]	Result [dB(μV/m)]	Limit [dB(μV/m)]	Margin [dB]	Height [cm]	Angle [°]
1	2832.372	34.7	3.4	38.1	54.0	15.9	248.1	307.4
2	3396.963	34.9	4.6	39.5	54.0	14.5	185.5	55.0
3	4881.812	26.2	10.7	36.9	54.0	17.1	200.5	7.4
4	5085.549	25.8	11.5	37.3	54.0	16.7	431.9	321.6

[EDR(3DH5)/2480MHz]

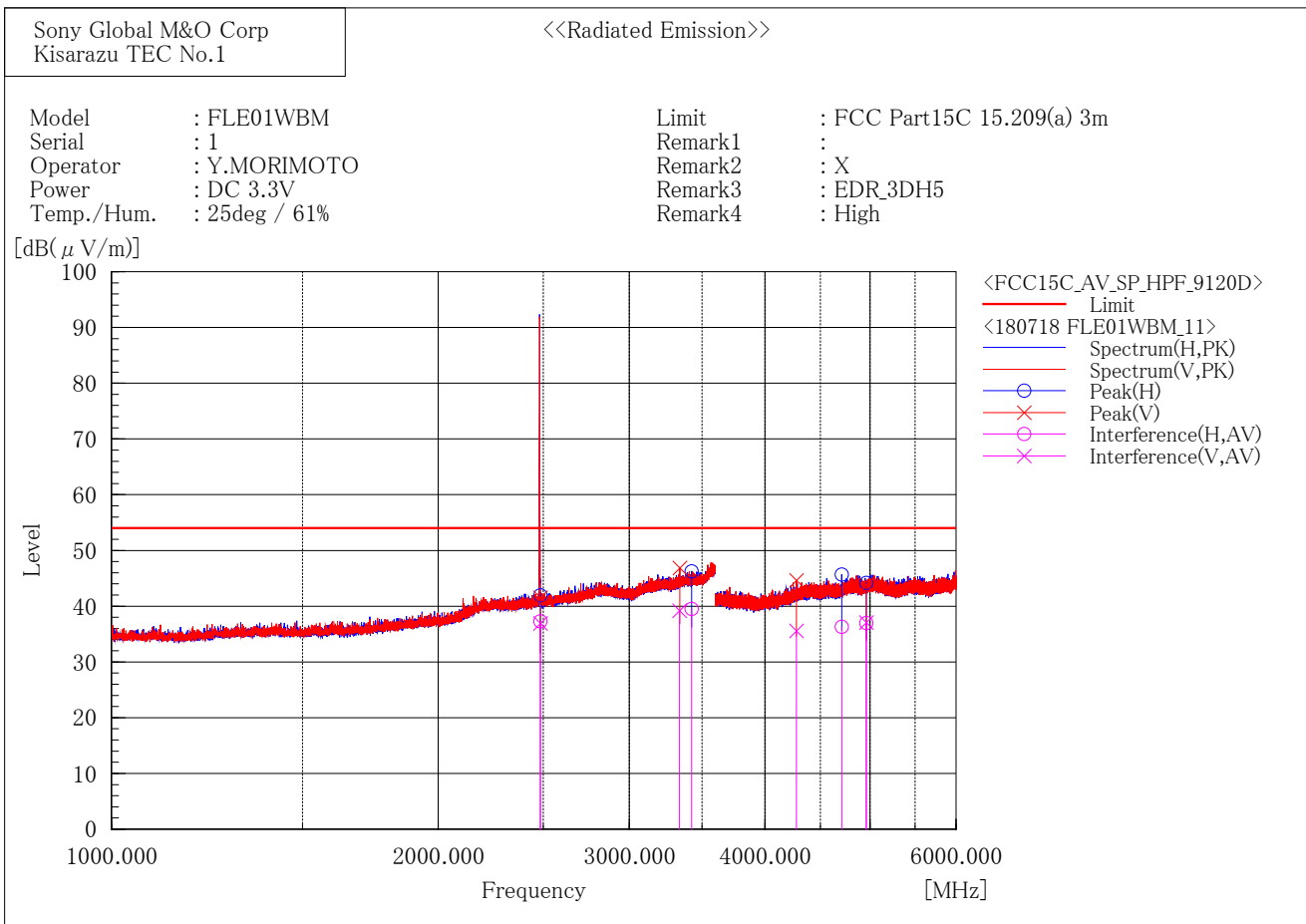

Final Result

--- Horizontal Polarization (AV)---

No.	Frequency [MHz]	Reading [dB(μV)]	c. f [dB(1/m)]	Result [dB(μV/m)]	Limit [dB(μV/m)]	Margin [dB]	Height [cm]	Angle [°]
1	2483.500	35.4	1.9	37.3	54.0	16.8	127.1	138.3
2	3424.171	34.8	4.7	39.5	54.0	14.5	119.1	350.6
3	4707.662	25.9	10.4	36.3	54.0	17.7	431.0	320.9
4	4959.620	26.0	11.0	37.0	54.0	17.0	381.9	13.5

--- Vertical Polarization (AV)---

No.	Frequency [MHz]	Reading [dB(μV)]	c. f [dB(1/m)]	Result [dB(μV/m)]	Limit [dB(μV/m)]	Margin [dB]	Height [cm]	Angle [°]
1	2483.500	35.0	1.9	36.9	54.0	17.1	283.2	24.7
2	3337.515	34.8	4.4	39.2	54.0	14.8	267.3	134.3
3	4276.083	26.0	9.6	35.6	54.0	18.4	294.8	115.3
4	4959.580	26.1	11.0	37.1	54.0	16.9	111.0	168.2

[EDR(3DH5)/2402MHz]

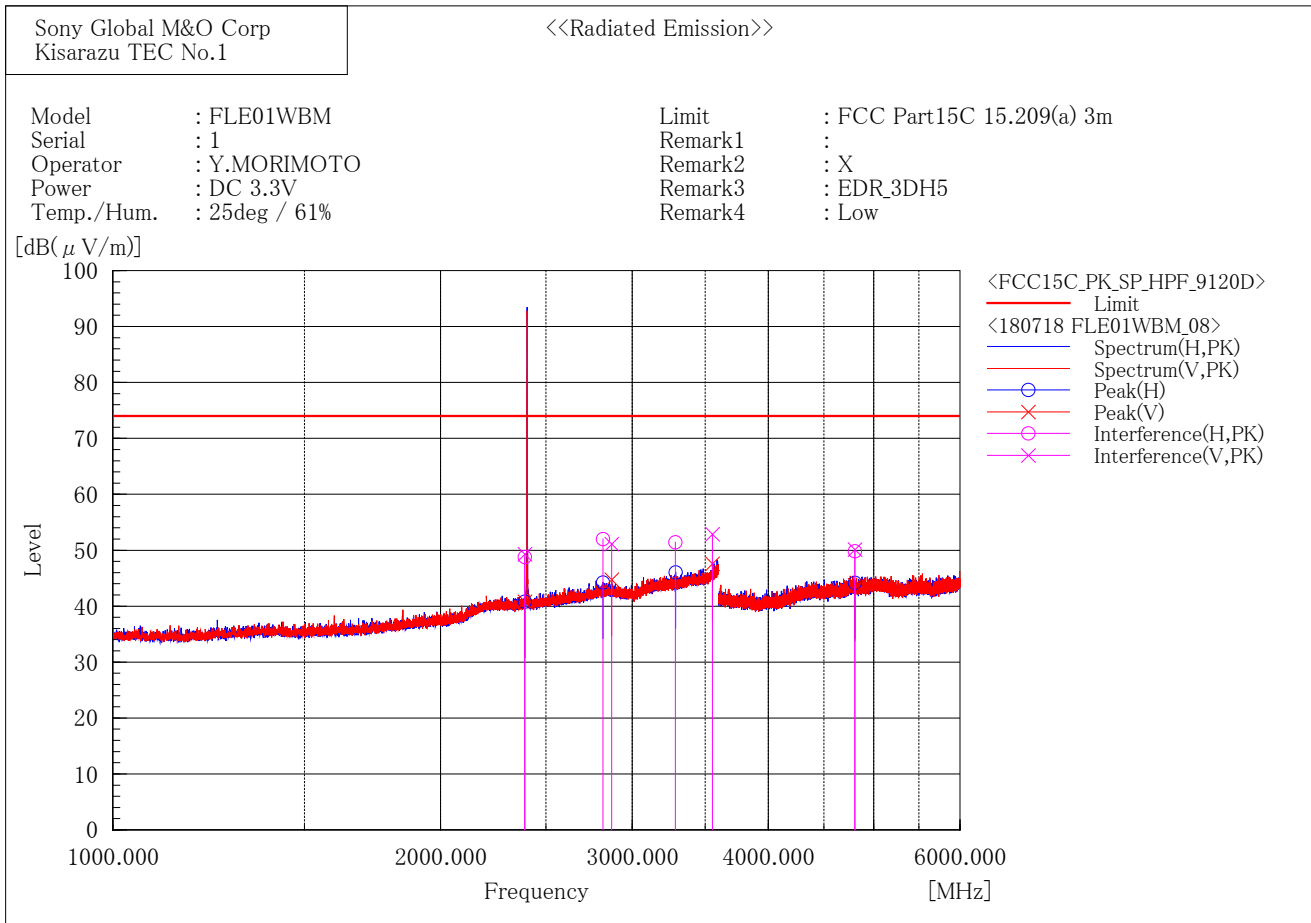

Final Result

--- Horizontal Polarization (PK)---

No.	Frequency [MHz]	Reading [dB(μV)]	c. f [dB(1/m)]	Result [dB(μV/m)]	Limit [dB(μV/m)]	Margin [dB]	Height [cm]	Angle [°]
1	2390.000	47.3	1.5	48.8	74.0	25.2	428.7	261.3
2	2820.509	48.6	3.4	52.0	74.0	22.0	221.5	144.7
3	3285.780	47.1	4.3	51.4	74.0	22.6	115.0	225.7
4	4803.455	38.8	11.0	49.8	74.0	24.2	141.8	66.3

--- Vertical Polarization (PK)---

No.	Frequency [MHz]	Reading [dB(μV)]	c. f [dB(1/m)]	Result [dB(μV/m)]	Limit [dB(μV/m)]	Margin [dB]	Height [cm]	Angle [°]
1	2390.000	47.8	1.5	49.3	74.0	24.7	196.9	307.2
2	2872.633	47.5	3.6	51.1	74.0	22.9	189.5	208.7
3	3554.538	47.4	5.5	52.9	74.0	21.1	239.1	296.0
4	4804.120	39.1	11.0	50.1	74.0	23.9	105.5	255.5

[EDR(3DH5)/2441MHz]

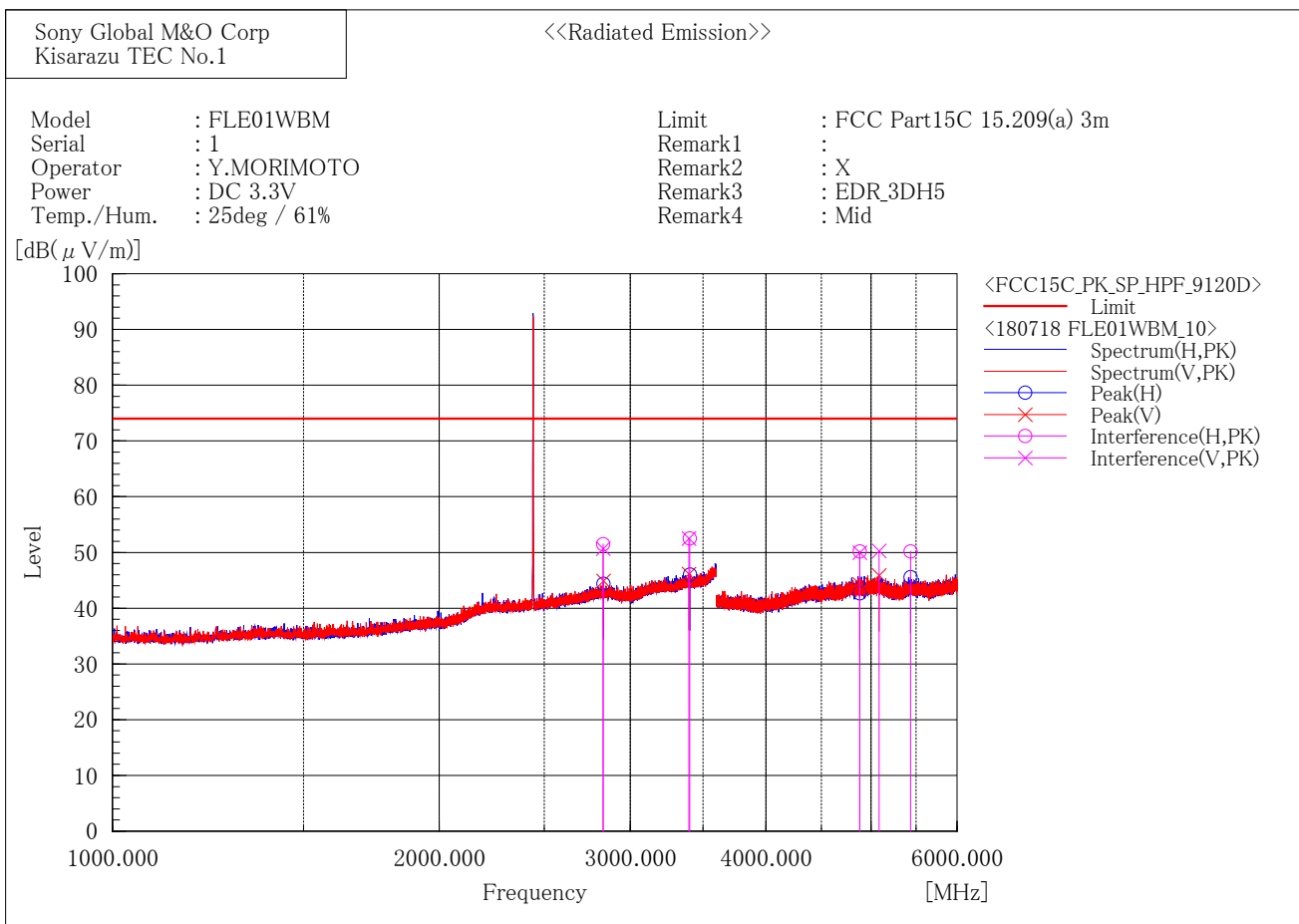

Final Result

--- Horizontal Polarization (PK)---

No.	Frequency [MHz]	Reading [dB(μV)]	c. f [dB(1/m)]	Result [dB(μV/m)]	Limit [dB(μV/m)]	Margin [dB]	Height [cm]	Angle [°]
1	2831.751	48.1	3.4	51.5	74.0	22.5	431.0	214.7
2	3404.228	47.9	4.6	52.5	74.0	21.5	122.5	95.5
3	4880.808	39.5	10.7	50.2	74.0	23.8	205.8	212.4
4	5436.438	38.9	11.3	50.2	74.0	23.8	105.6	209.8

--- Vertical Polarization (PK)---

No.	Frequency [MHz]	Reading [dB(μV)]	c. f [dB(1/m)]	Result [dB(μV/m)]	Limit [dB(μV/m)]	Margin [dB]	Height [cm]	Angle [°]
1	2832.483	47.3	3.4	50.7	74.0	23.3	248.1	309.3
2	3396.998	47.9	4.6	52.5	74.0	21.5	185.5	52.9
3	4882.257	39.3	10.7	50.0	74.0	24.0	200.5	5.4
4	5086.145	38.8	11.5	50.3	74.0	23.7	431.9	321.6

[EDR(3DH5)/2480MHz]

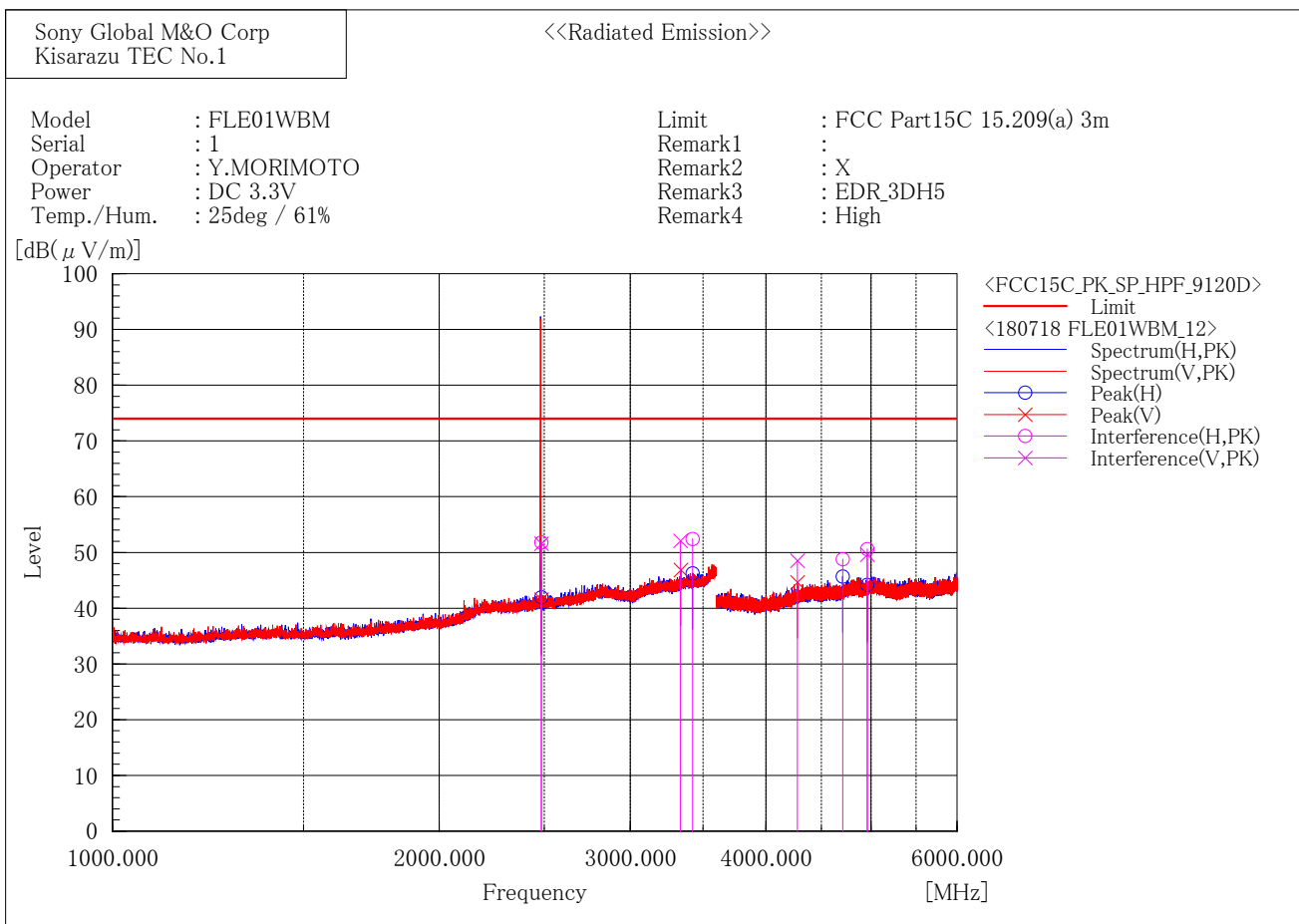

6 GHz - 18 GHz

[BDR(DH5)/2402MHz]

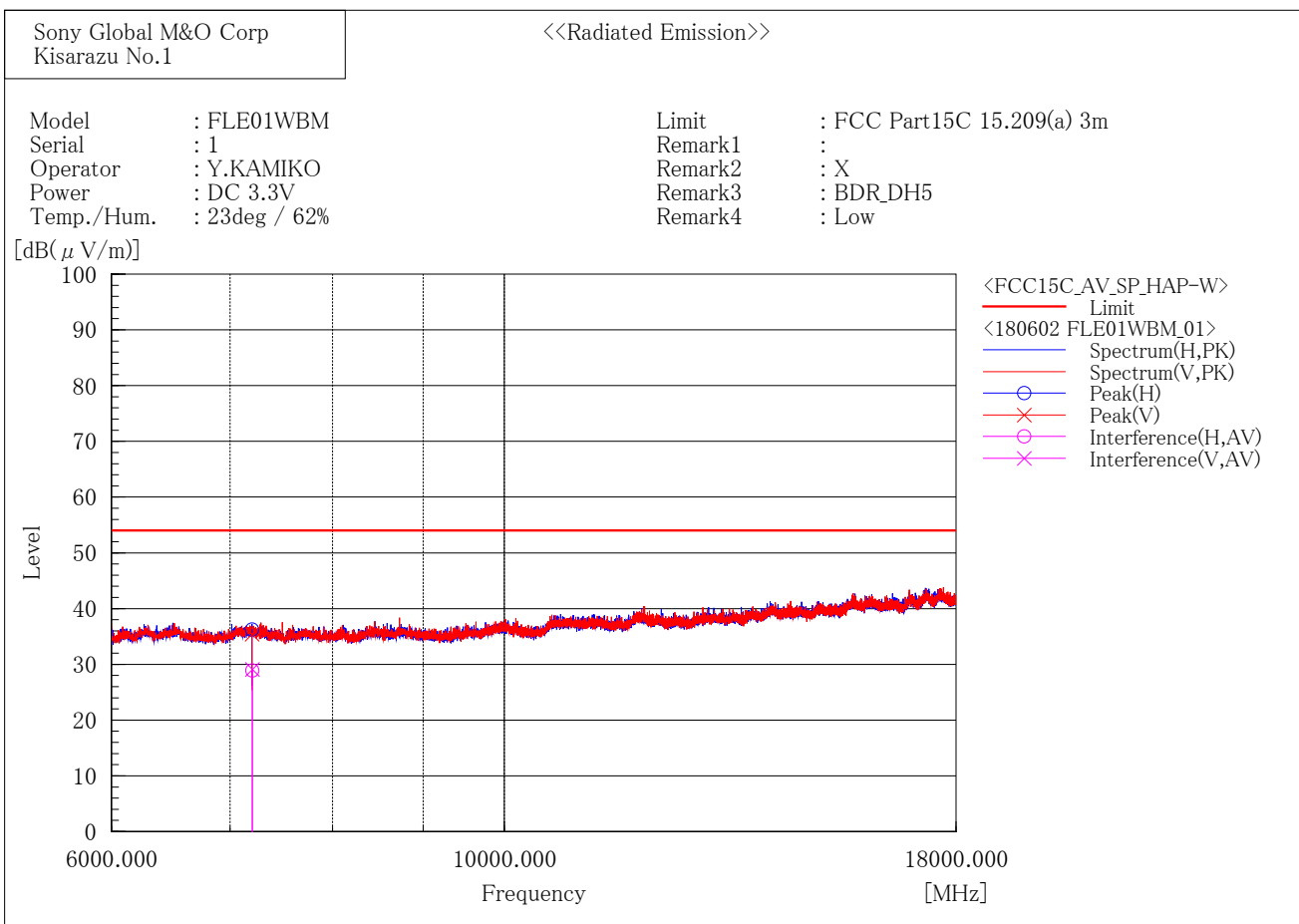

Final Result

--- Horizontal Polarization (AV)---

No.	Frequency [MHz]	Reading [dB(μV)]	c. f [dB(1/m)]	Result [dB(μV/m)]	Limit [dB(μV/m)]	Margin [dB]	Height [cm]	Angle [°]
1	7205.866	38.0	-9.1	28.9	54.0	25.1	357.0	35.2

--- Vertical Polarization (AV)---

No.	Frequency [MHz]	Reading [dB(μV)]	c. f [dB(1/m)]	Result [dB(μV/m)]	Limit [dB(μV/m)]	Margin [dB]	Height [cm]	Angle [°]
1	7206.020	38.2	-9.1	29.1	54.0	24.9	308.0	145.9

[BDR(DH5)/2441MHz]

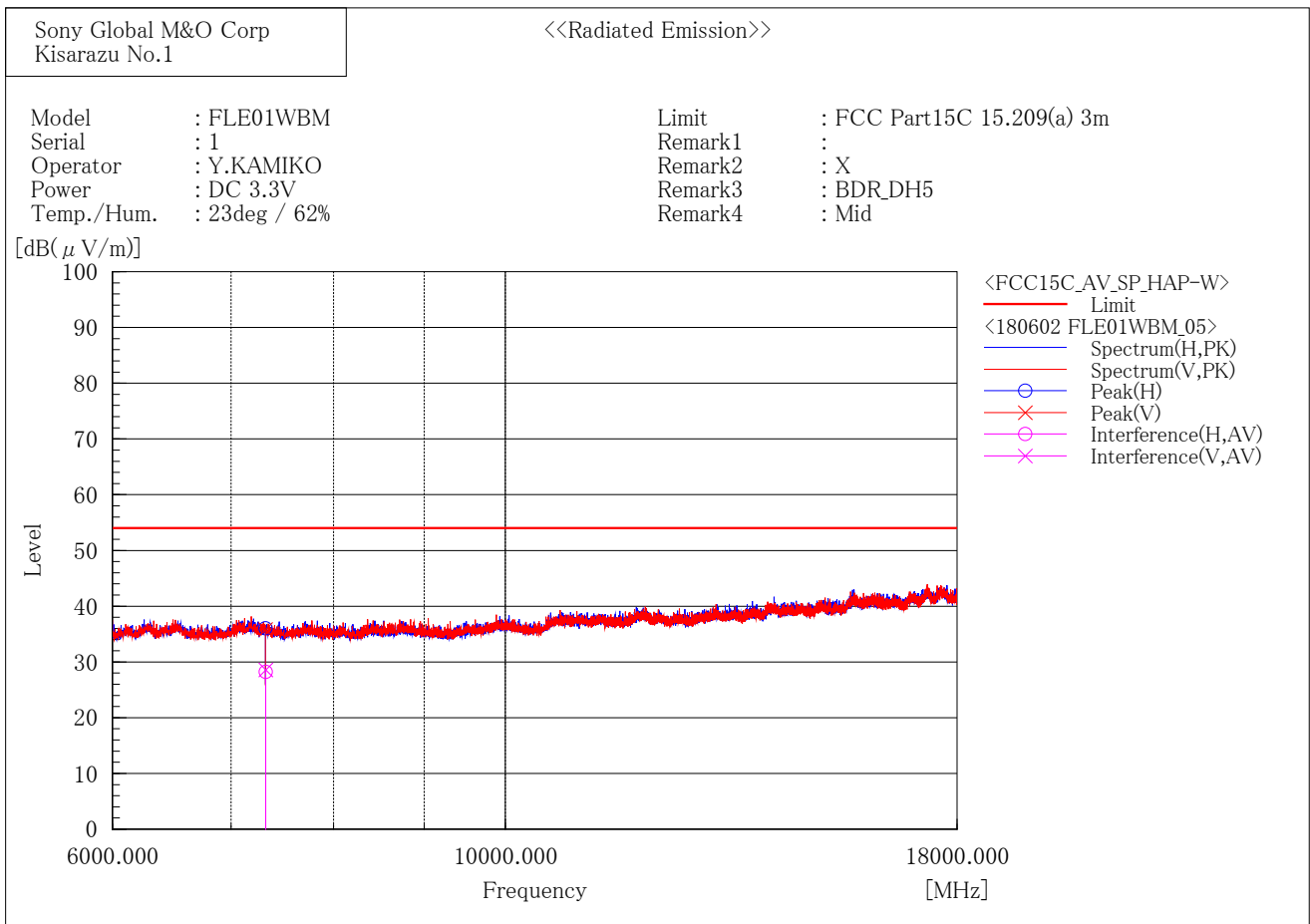

Final Result

--- Horizontal Polarization (AV)---

No.	Frequency [MHz]	Reading [dB(μV)]	c. f [dB(1/m)]	Result [dB(μV/m)]	Limit [dB(μV/m)]	Margin [dB]	Height [cm]	Angle [°]
1	7322.995	37.8	-9.6	28.2	54.0	25.8	379.0	33.1

--- Vertical Polarization (AV)---

No.	Frequency [MHz]	Reading [dB(μV)]	c. f [dB(1/m)]	Result [dB(μV/m)]	Limit [dB(μV/m)]	Margin [dB]	Height [cm]	Angle [°]
1	7323.028	38.2	-9.6	28.6	54.0	25.4	366.8	152.1

[BDR(DH5)/2480MHz]

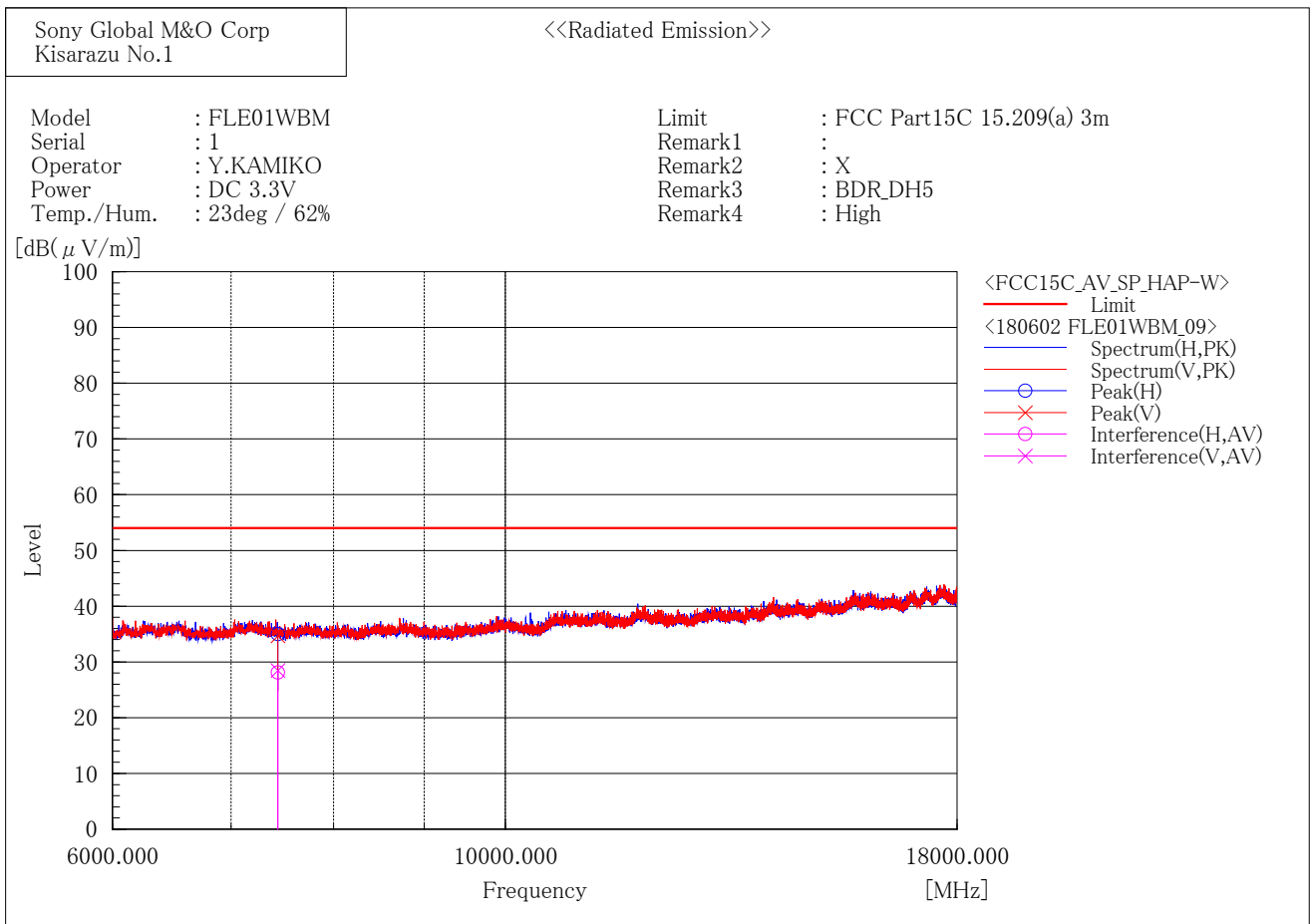

Final Result

--- Horizontal Polarization (AV)---

No.	Frequency [MHz]	Reading [dB(μV)]	c. f [dB(1/m)]	Result [dB(μV/m)]	Limit [dB(μV/m)]	Margin [dB]	Height [cm]	Angle [°]
1	7439.943	37.9	-9.8	28.1	54.0	25.9	342.2	40.9

--- Vertical Polarization (AV)---

No.	Frequency [MHz]	Reading [dB(μV)]	c. f [dB(1/m)]	Result [dB(μV/m)]	Limit [dB(μV/m)]	Margin [dB]	Height [cm]	Angle [°]
1	7439.916	38.3	-9.8	28.5	54.0	25.5	339.0	156.5

[BDR(DH5)/2402MHz]

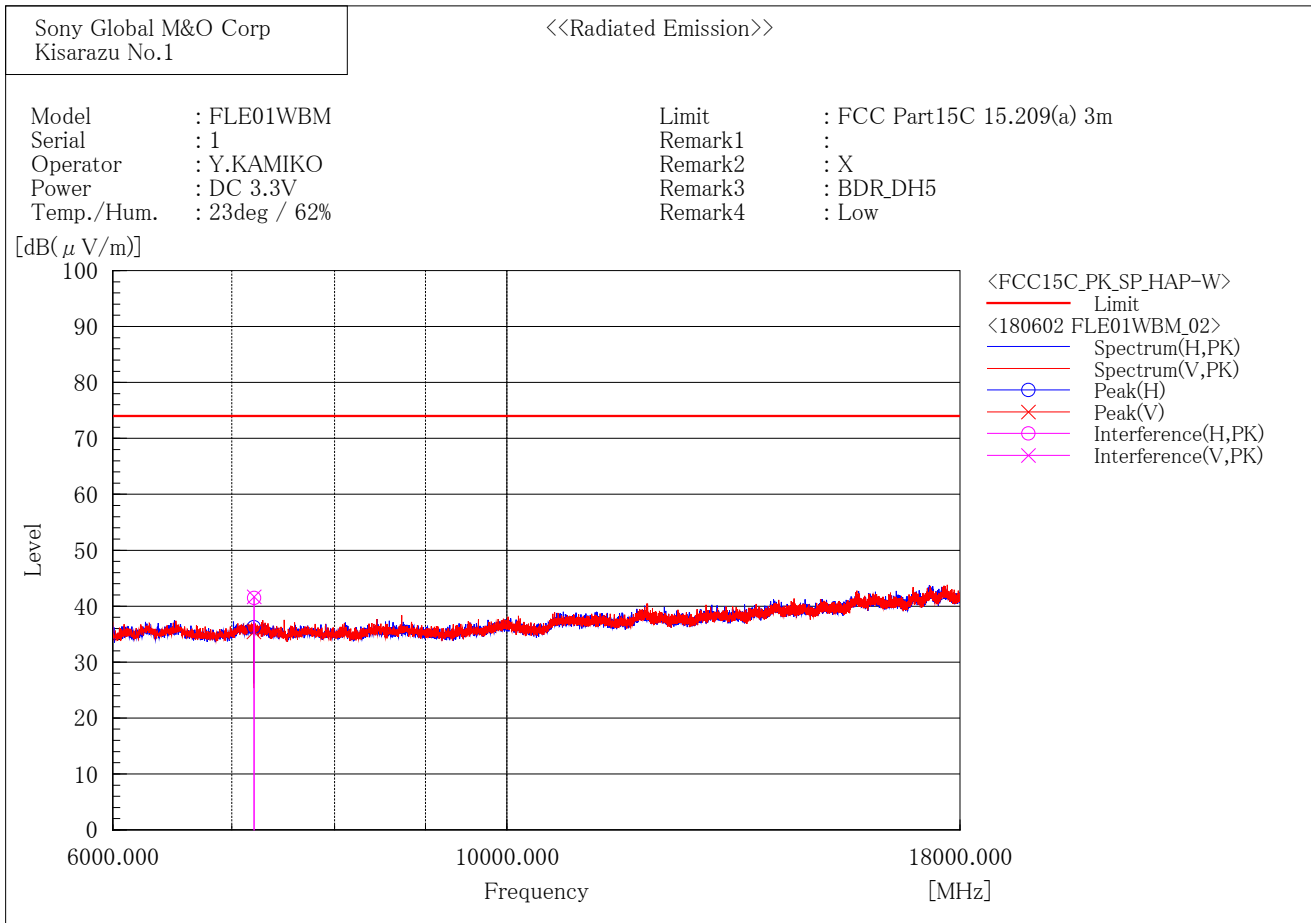

Final Result

--- Horizontal Polarization (PK)---

No.	Frequency [MHz]	Reading [dB(μV)]	c. f [dB(1/m)]	Result [dB(μV/m)]	Limit [dB(μV/m)]	Margin [dB]	Height [cm]	Angle [°]
1	7205.823	50.6	-9.1	41.5	74.0	32.5	357.0	37.3

--- Vertical Polarization (PK)---

No.	Frequency [MHz]	Reading [dB(μV)]	c. f [dB(1/m)]	Result [dB(μV/m)]	Limit [dB(μV/m)]	Margin [dB]	Height [cm]	Angle [°]
1	7206.393	50.8	-9.1	41.7	74.0	32.3	308.0	145.9

[BDR(DH5)/2441MHz]

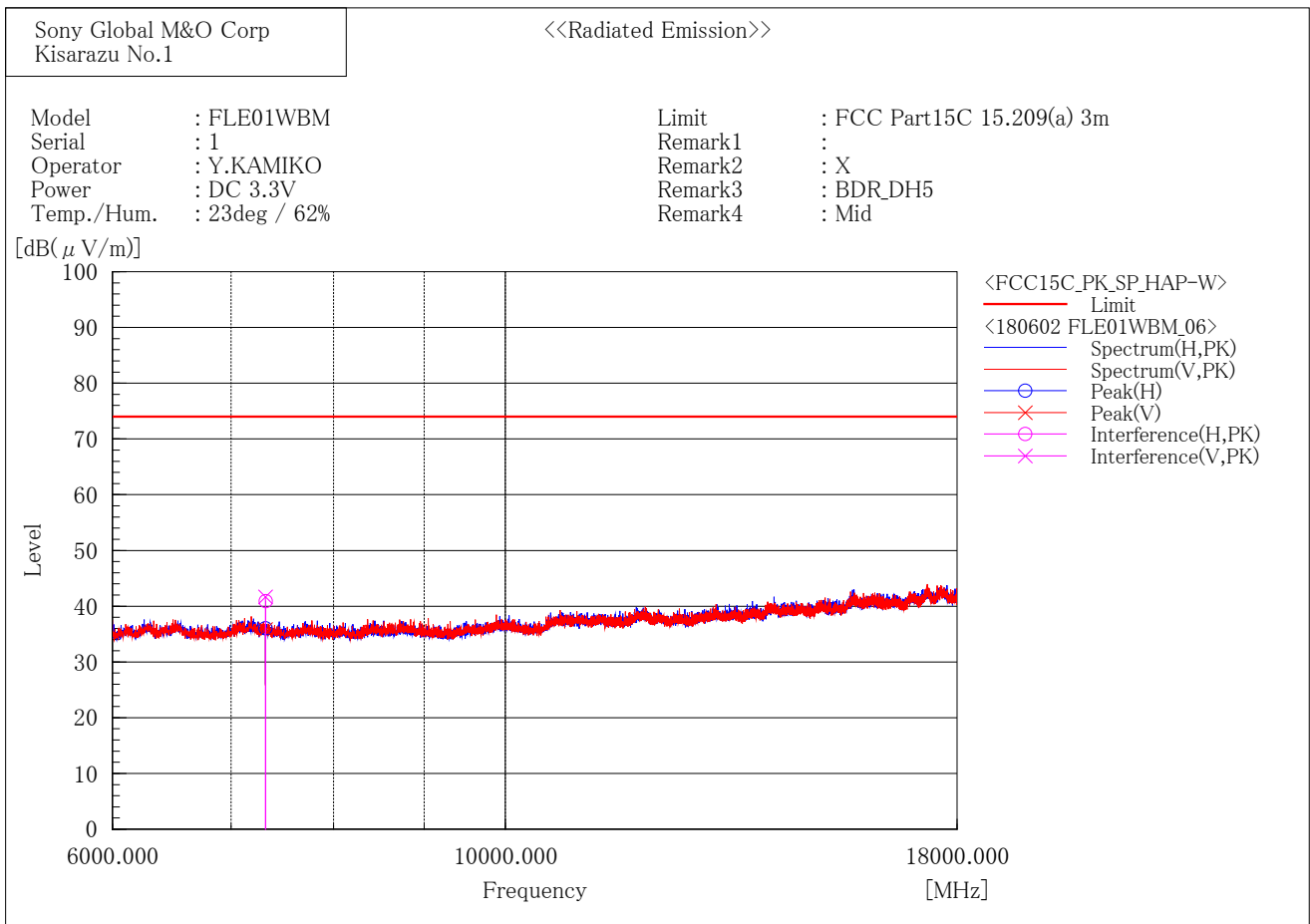

Final Result

--- Horizontal Polarization (PK)---

No.	Frequency [MHz]	Reading [dB(μV)]	c. f [dB(1/m)]	Result [dB(μV/m)]	Limit [dB(μV/m)]	Margin [dB]	Height [cm]	Angle [°]
1	7324.078	50.5	-9.6	40.9	74.0	33.1	383.0	37.7

--- Vertical Polarization (PK)---

No.	Frequency [MHz]	Reading [dB(μV)]	c. f [dB(1/m)]	Result [dB(μV/m)]	Limit [dB(μV/m)]	Margin [dB]	Height [cm]	Angle [°]
1	7322.098	51.3	-9.6	41.7	74.0	32.3	366.8	152.1

[BDR(DH5)/2480MHz]

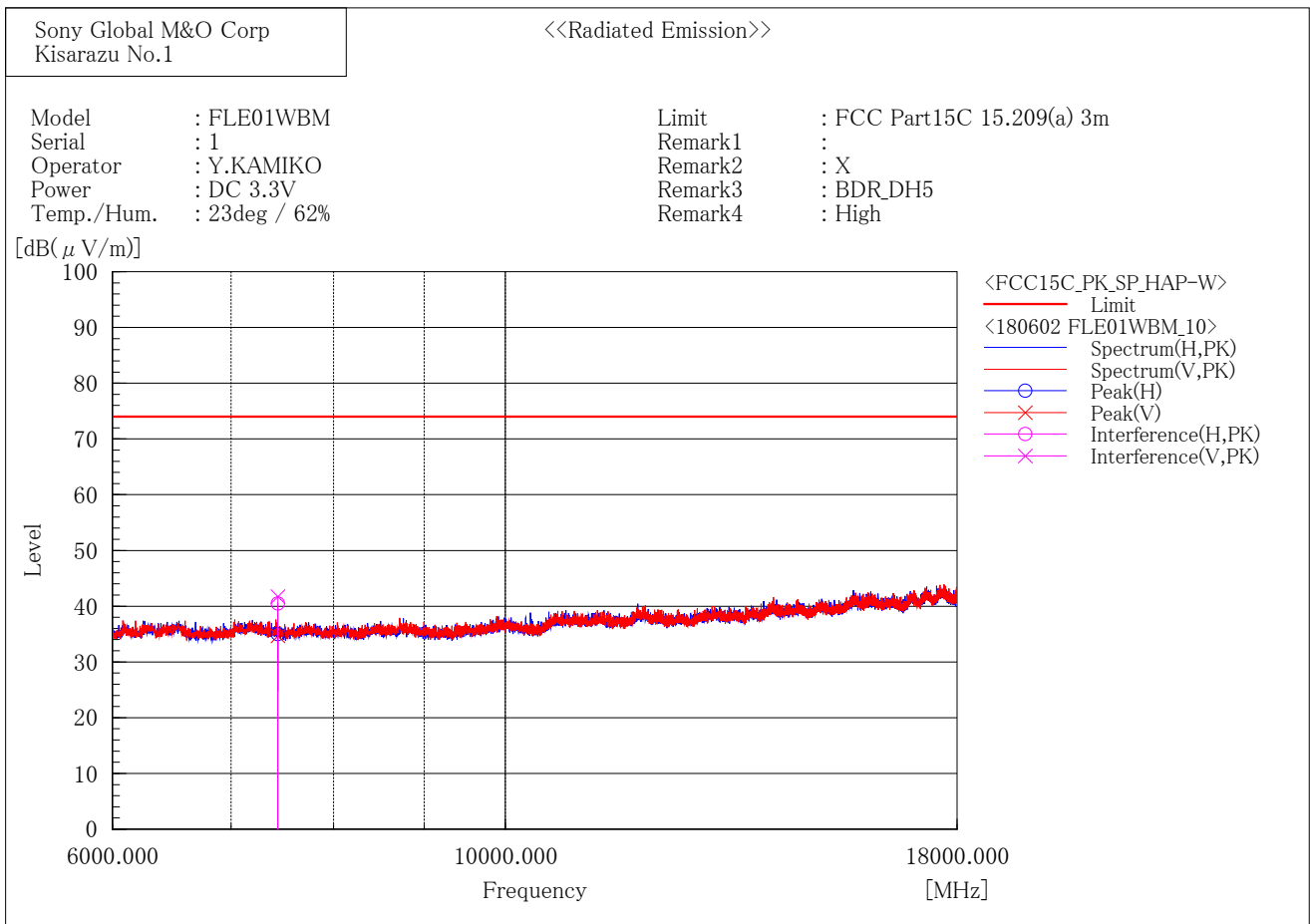

Final Result

--- Horizontal Polarization (PK)---

No.	Frequency [MHz]	Reading [dB(μV)]	c. f [dB(1/m)]	Result [dB(μV/m)]	Limit [dB(μV/m)]	Margin [dB]	Height [cm]	Angle [°]
1	7440.316	50.3	-9.8	40.5	74.0	33.5	335.0	41.9

--- Vertical Polarization (PK)---

No.	Frequency [MHz]	Reading [dB(μV)]	c. f [dB(1/m)]	Result [dB(μV/m)]	Limit [dB(μV/m)]	Margin [dB]	Height [cm]	Angle [°]
1	7439.802	51.5	-9.8	41.7	74.0	32.3	339.0	156.5

[EDR(3DH5)/2402MHz]

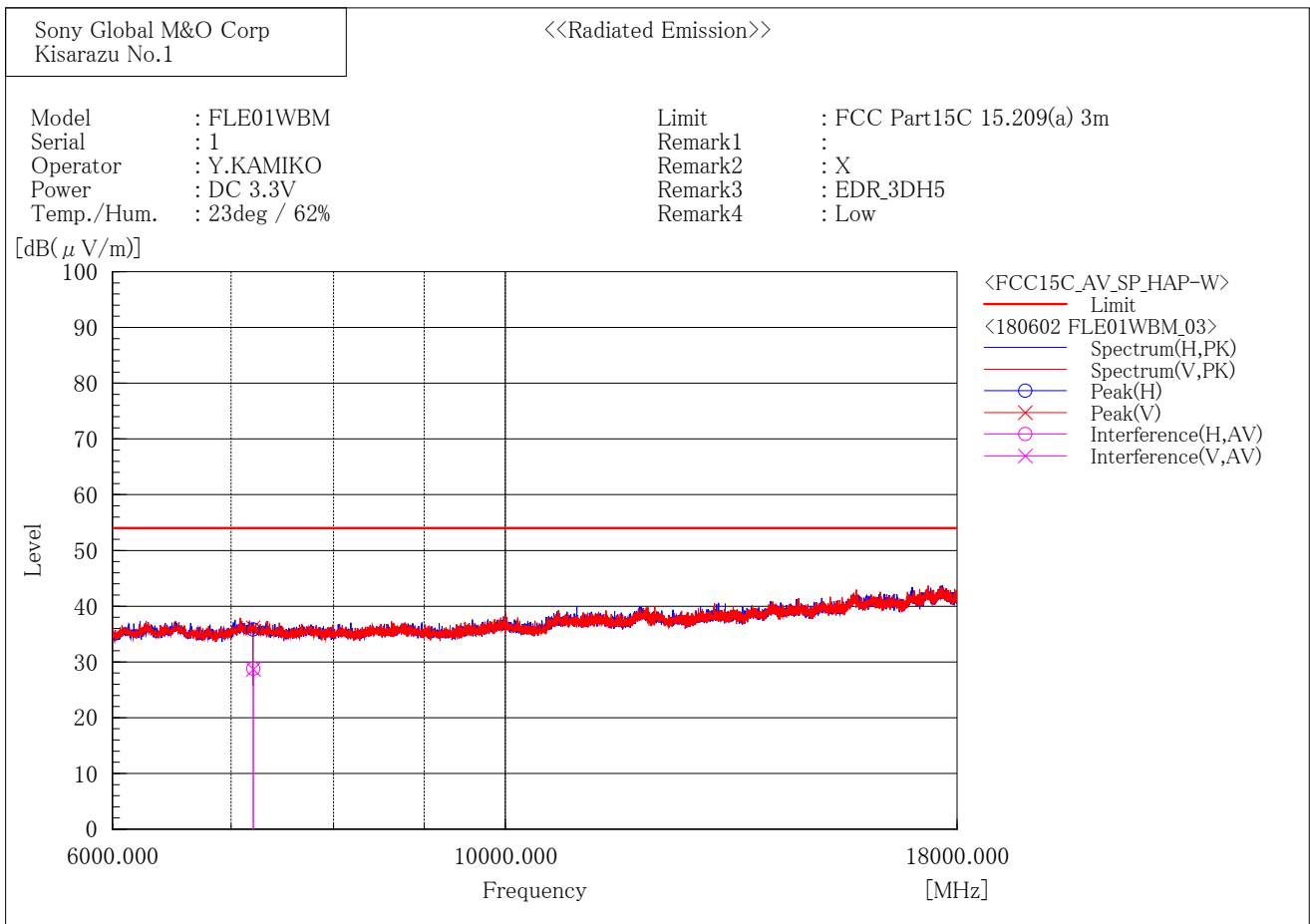

Final Result

--- Horizontal Polarization (AV)---

No.	Frequency [MHz]	Reading [dB(μV)]	c. f [dB(1/m)]	Result [dB(μV/m)]	Limit [dB(μV/m)]	Margin [dB]	Height [cm]	Angle [°]
1	7205.488	37.9	-9.1	28.8	54.0	25.2	352.4	34.8

--- Vertical Polarization (AV)---

No.	Frequency [MHz]	Reading [dB(μV)]	c. f [dB(1/m)]	Result [dB(μV/m)]	Limit [dB(μV/m)]	Margin [dB]	Height [cm]	Angle [°]
1	7205.855	37.8	-9.1	28.7	54.0	25.3	306.6	148.3

[EDR(3DH5)/2441MHz]

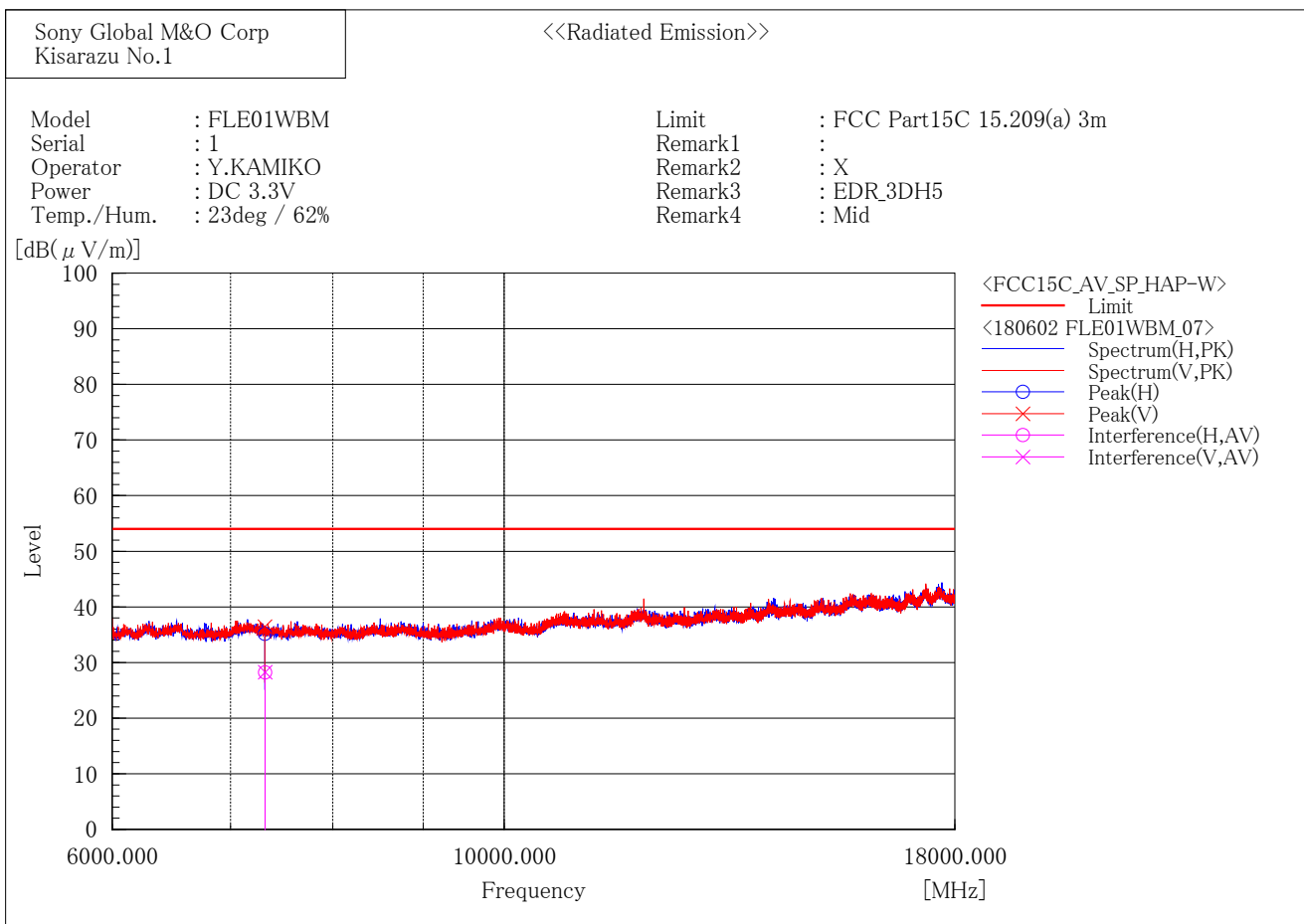

Final Result

--- Horizontal Polarization (AV)---

No.	Frequency [MHz]	Reading [dB(μV)]	c. f [dB(1/m)]	Result [dB(μV/m)]	Limit [dB(μV/m)]	Margin [dB]	Height [cm]	Angle [°]
1	7323.125	37.8	-9.6	28.2	54.0	25.8	336.0	32.1

--- Vertical Polarization (AV)---

No.	Frequency [MHz]	Reading [dB(μV)]	c. f [dB(1/m)]	Result [dB(μV/m)]	Limit [dB(μV/m)]	Margin [dB]	Height [cm]	Angle [°]
1	7322.965	37.9	-9.6	28.3	54.0	25.7	344.0	150.7

[EDR(3DH5)/2480MHz]

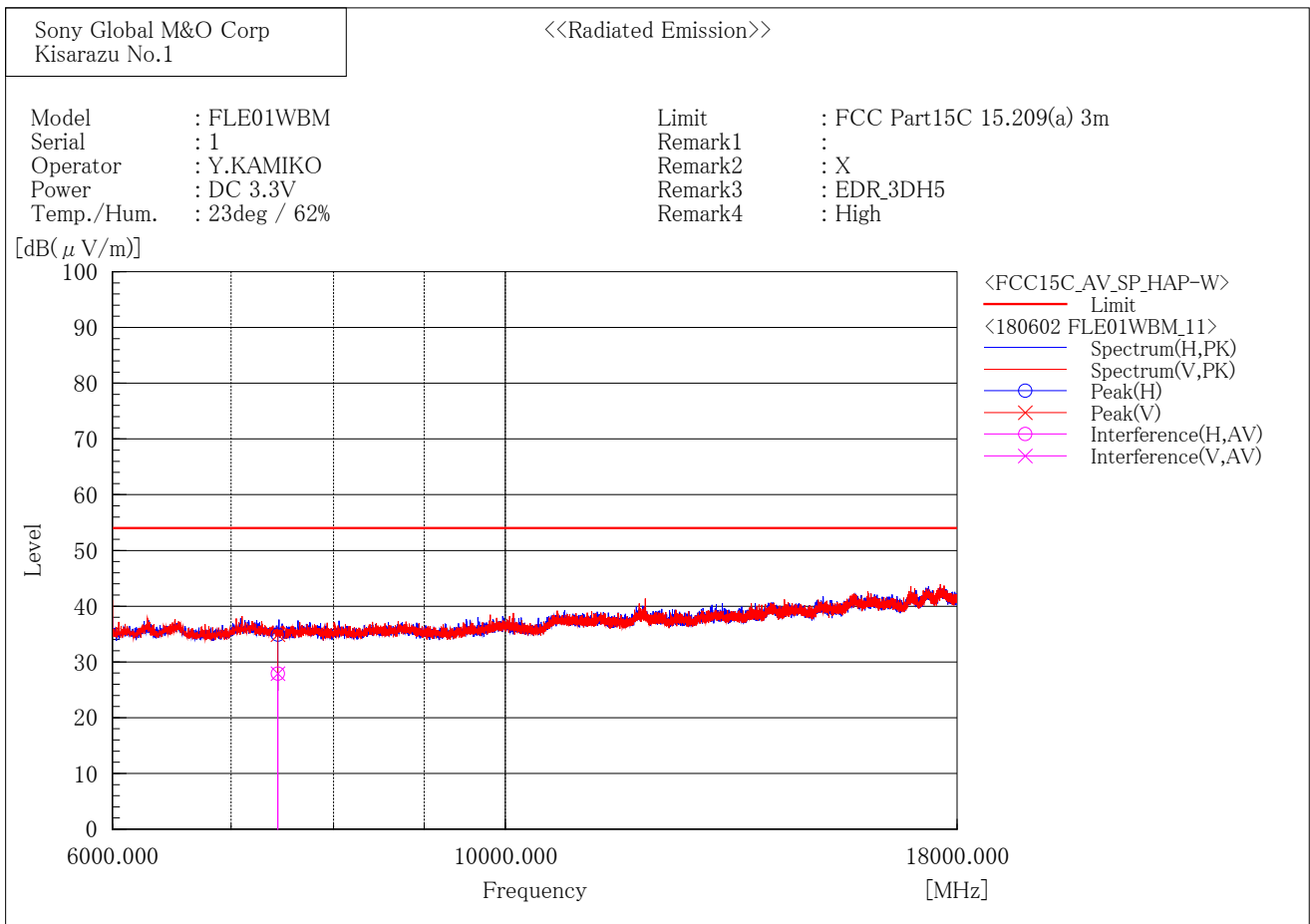

Final Result

--- Horizontal Polarization (AV)---

No.	Frequency [MHz]	Reading [dB(μV)]	c. f [dB(1/m)]	Result [dB(μV/m)]	Limit [dB(μV/m)]	Margin [dB]	Height [cm]	Angle [°]
1	7440.024	37.7	-9.8	27.9	54.0	26.1	332.3	57.9

--- Vertical Polarization (AV)---

No.	Frequency [MHz]	Reading [dB(μV)]	c. f [dB(1/m)]	Result [dB(μV/m)]	Limit [dB(μV/m)]	Margin [dB]	Height [cm]	Angle [°]
1	7440.102	37.7	-9.8	27.9	54.0	26.1	326.0	180.9

[EDR(3DH5)/2402MHz]

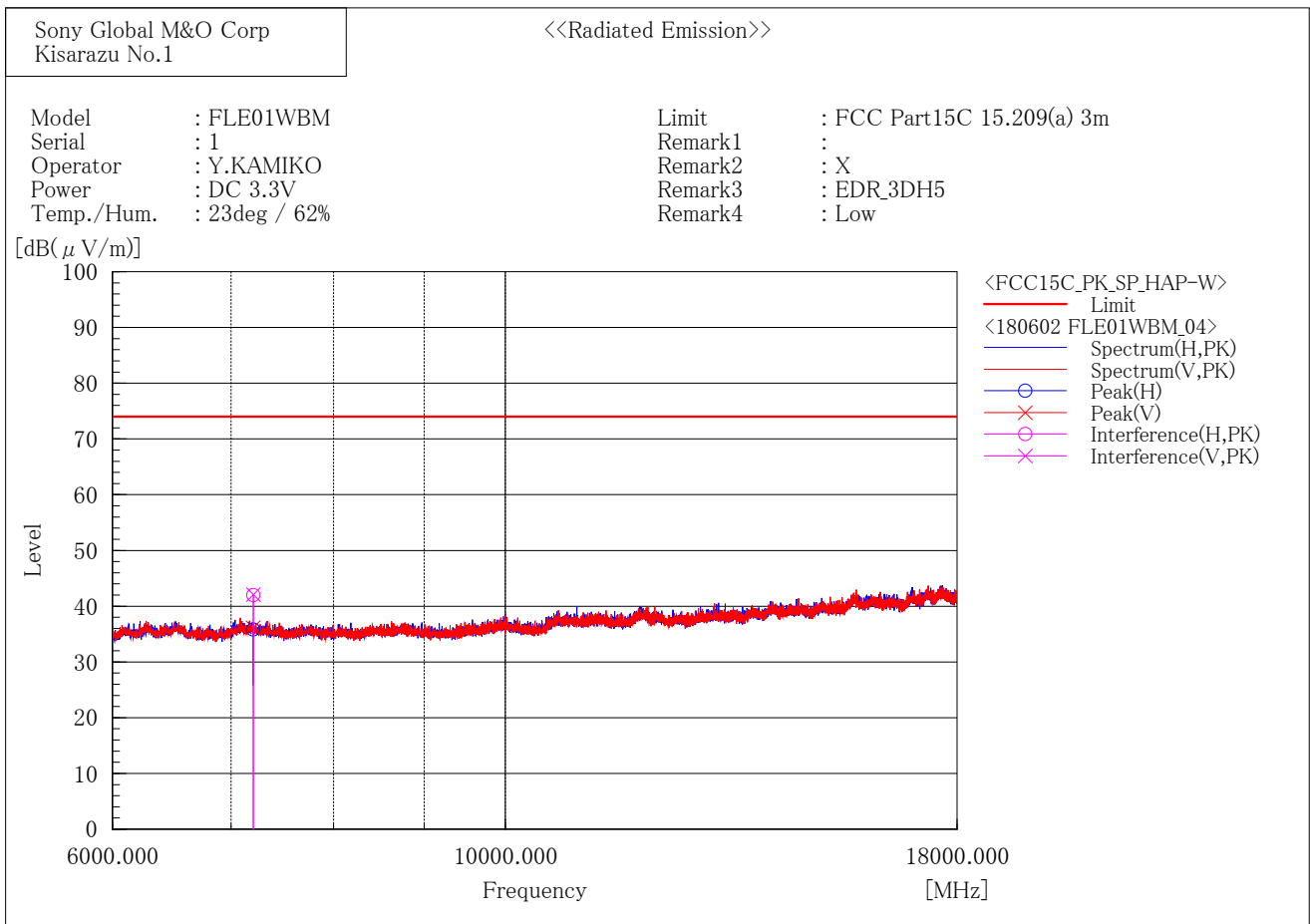

Final Result

--- Horizontal Polarization (PK)---

No.	Frequency [MHz]	Reading [dB(μV)]	c. f [dB(1/m)]	Result [dB(μV/m)]	Limit [dB(μV/m)]	Margin [dB]	Height [cm]	Angle [°]
1	7205.500	51.1	-9.1	42.0	74.0	32.0	352.4	34.8

--- Vertical Polarization (PK)---

No.	Frequency [MHz]	Reading [dB(μV)]	c. f [dB(1/m)]	Result [dB(μV/m)]	Limit [dB(μV/m)]	Margin [dB]	Height [cm]	Angle [°]
1	7206.071	51.2	-9.1	42.1	74.0	31.9	301.0	147.2

[EDR(3DH5)/2441MHz]

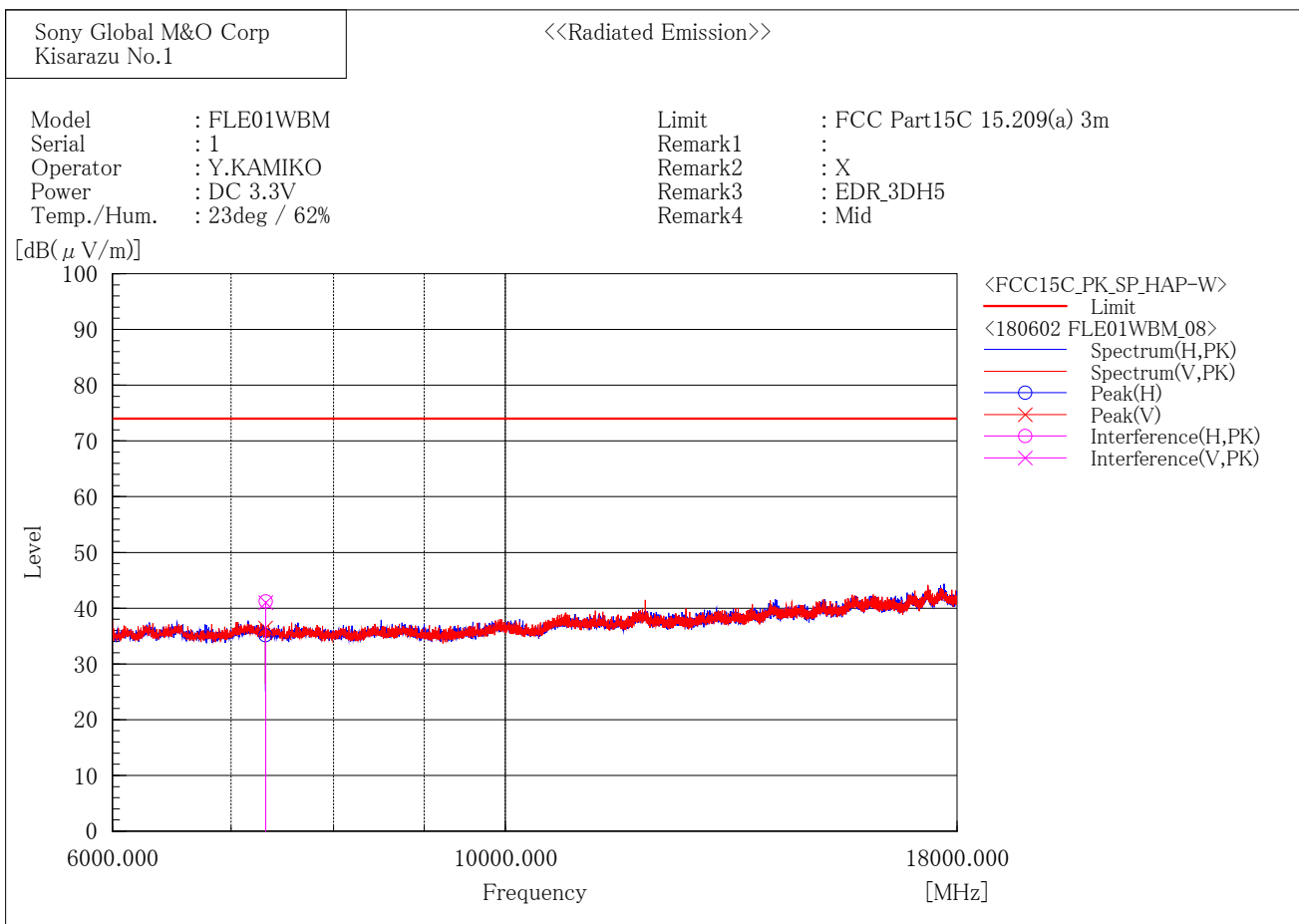

Final Result

--- Horizontal Polarization (PK)---

No.	Frequency [MHz]	Reading [dB(μV)]	c. f [dB(1/m)]	Result [dB(μV/m)]	Limit [dB(μV/m)]	Margin [dB]	Height [cm]	Angle [°]
1	7323.490	50.8	-9.6	41.2	74.0	32.8	336.0	32.1

--- Vertical Polarization (PK)---

No.	Frequency [MHz]	Reading [dB(μV)]	c. f [dB(1/m)]	Result [dB(μV/m)]	Limit [dB(μV/m)]	Margin [dB]	Height [cm]	Angle [°]
1	7324.055	50.6	-9.6	41.0	74.0	33.0	340.0	148.7

[EDR(3DH5)/2480MHz]

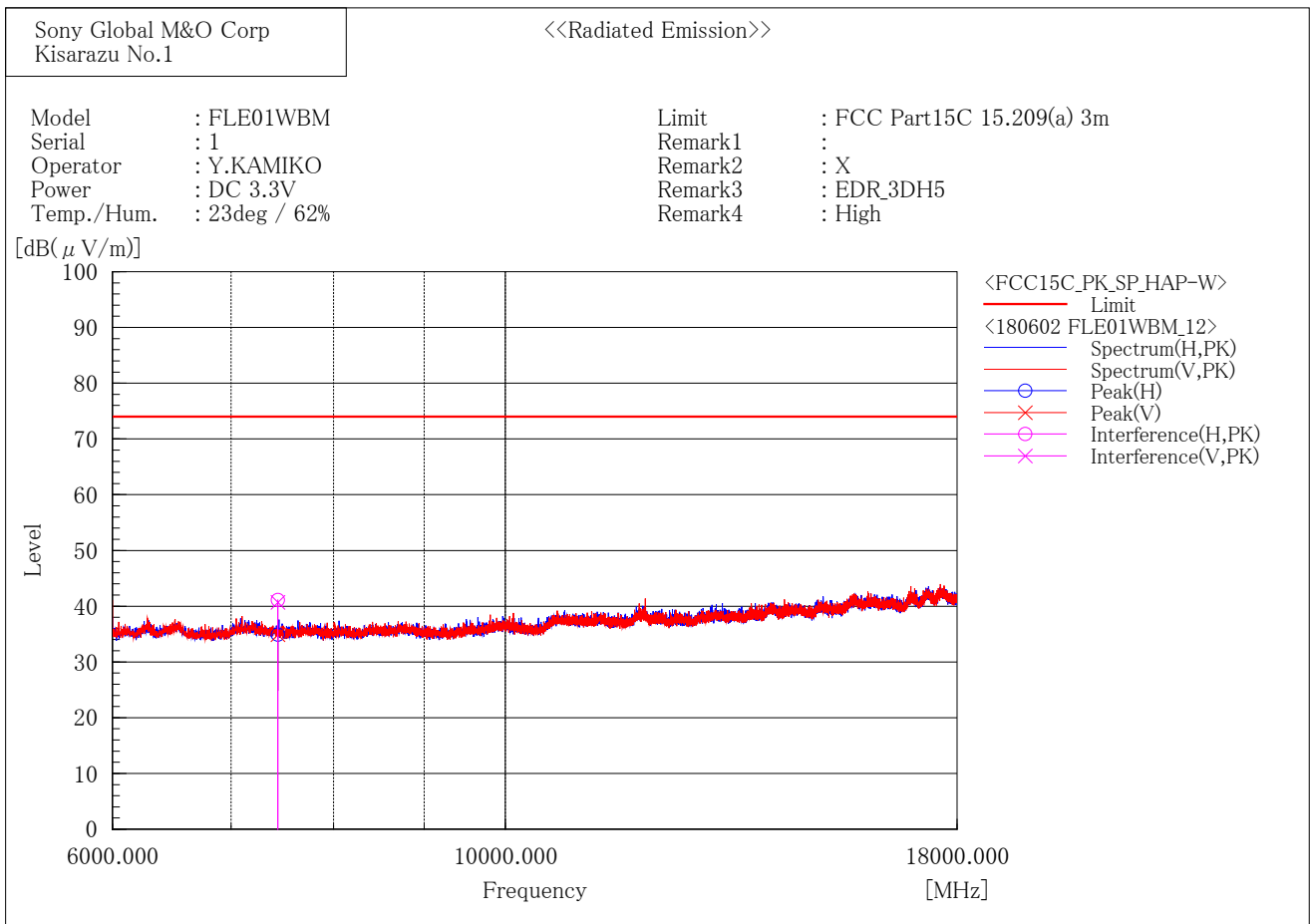

Final Result

--- Horizontal Polarization (PK)---

No.	Frequency [MHz]	Reading [dB(μV)]	c. f [dB(1/m)]	Result [dB(μV/m)]	Limit [dB(μV/m)]	Margin [dB]	Height [cm]	Angle [°]
1	7439.918	50.9	-9.8	41.1	74.0	32.9	332.3	57.9

--- Vertical Polarization (PK)---

No.	Frequency [MHz]	Reading [dB(μV)]	c. f [dB(1/m)]	Result [dB(μV/m)]	Limit [dB(μV/m)]	Margin [dB]	Height [cm]	Angle [°]
1	7439.703	50.5	-9.8	40.7	74.0	33.3	331.8	154.1

18 GHz – 24.835 GHz

[BDR(DH5)/2402MHz]

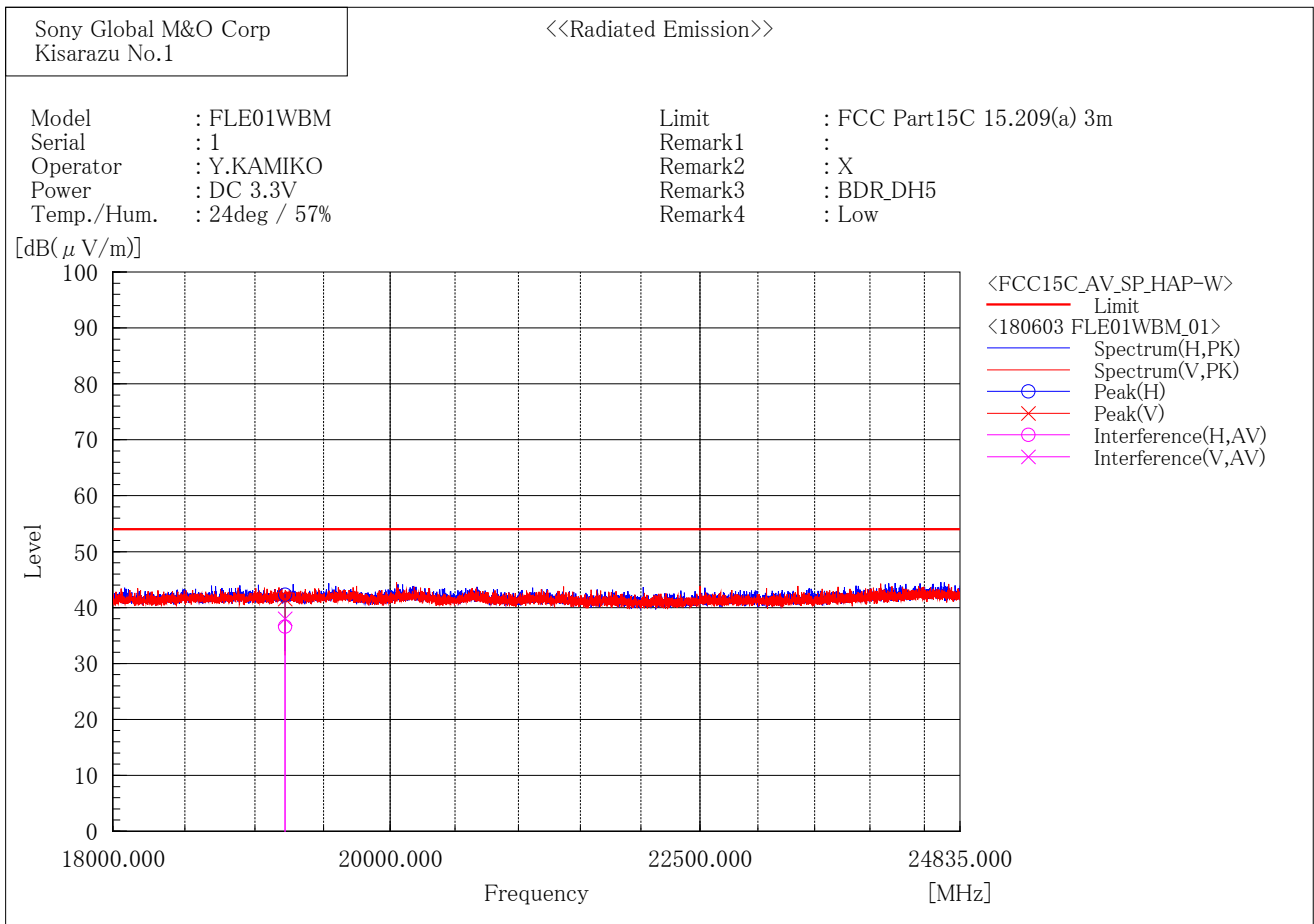

Final Result

--- Horizontal Polarization (AV)---

No.	Frequency [MHz]	Reading [dB(μV)]	c. f [dB(1/m)]	Result [dB(μV/m)]	Limit [dB(μV/m)]	Margin [dB]	Height [cm]	Angle [°]
1	19216.742	31.2	5.4	36.6	54.0	17.4	112.6	269.6

--- Vertical Polarization (AV)---

No.	Frequency [MHz]	Reading [dB(μV)]	c. f [dB(1/m)]	Result [dB(μV/m)]	Limit [dB(μV/m)]	Margin [dB]	Height [cm]	Angle [°]
1	19217.018	32.6	5.4	38.0	54.0	16.0	341.7	313.8

[BDR(DH5)/2441MHz]

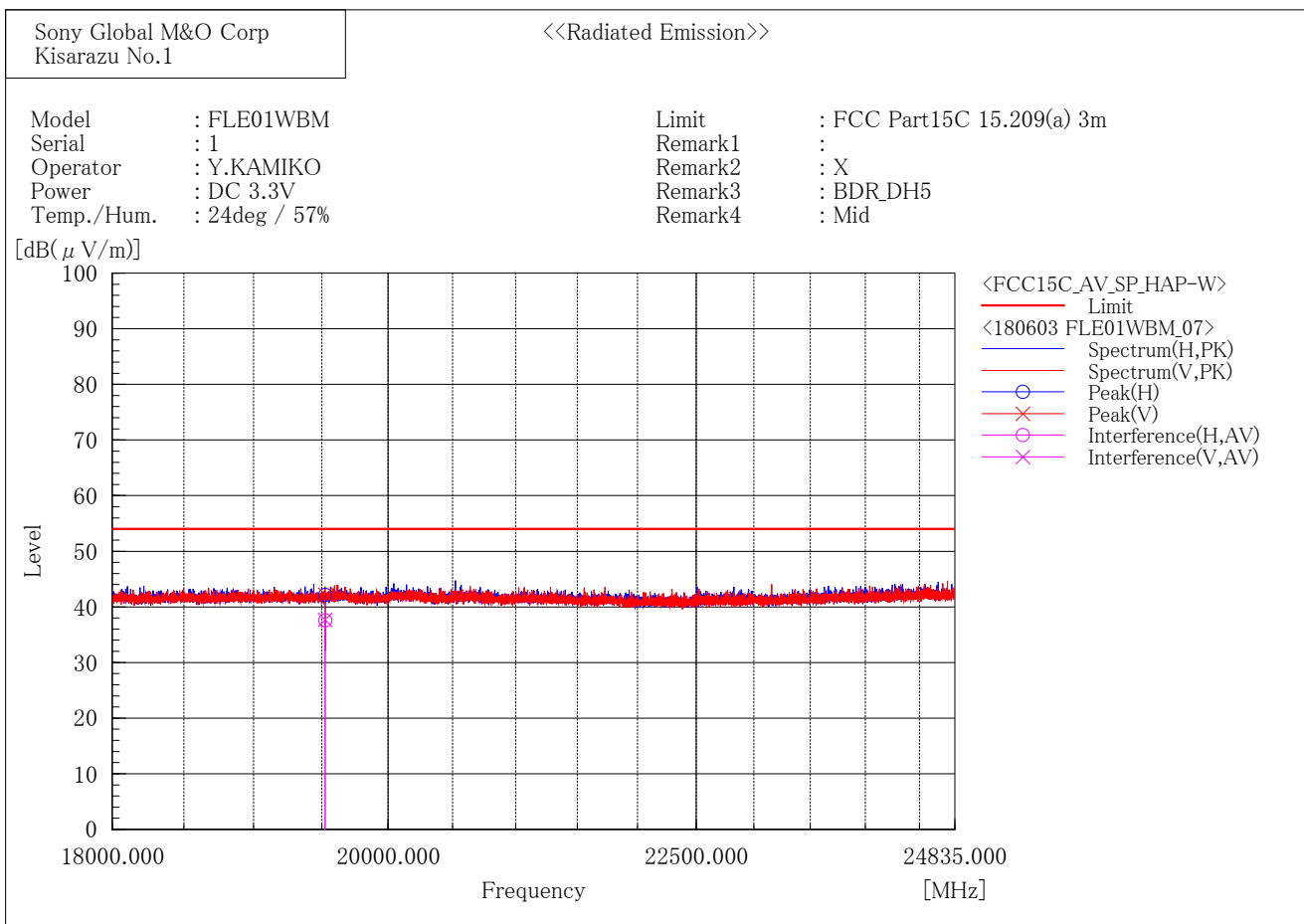

Final Result

--- Horizontal Polarization (AV)---

No.	Frequency [MHz]	Reading [dB(μV)]	c. f [dB(1/m)]	Result [dB(μV/m)]	Limit [dB(μV/m)]	Margin [dB]	Height [cm]	Angle [°]
1	19527.372	32.1	5.5	37.6	54.0	16.4	206.6	93.6

--- Vertical Polarization (AV)---

No.	Frequency [MHz]	Reading [dB(μV)]	c. f [dB(1/m)]	Result [dB(μV/m)]	Limit [dB(μV/m)]	Margin [dB]	Height [cm]	Angle [°]
1	19524.824	32.2	5.5	37.7	54.0	16.3	295.5	311.8

[BDR(DH5)/2480MHz]

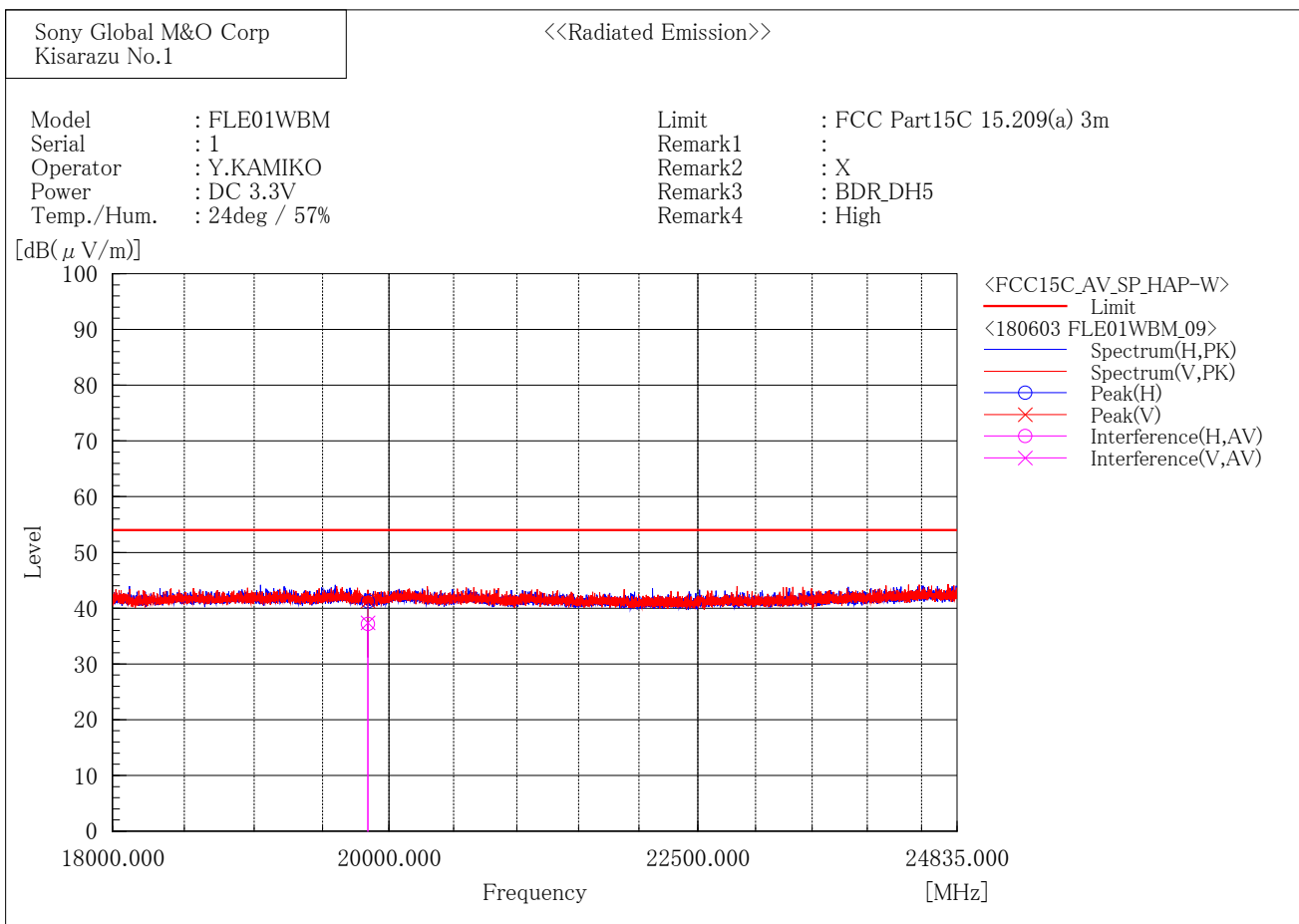

Final Result

--- Horizontal Polarization (AV)---

No.	Frequency [MHz]	Reading [dB(μV)]	c. f [dB(1/m)]	Result [dB(μV/m)]	Limit [dB(μV/m)]	Margin [dB]	Height [cm]	Angle [°]
1	19840.582	31.7	5.5	37.2	54.0	16.8	244.7	160.9

--- Vertical Polarization (AV)---

No.	Frequency [MHz]	Reading [dB(μV)]	c. f [dB(1/m)]	Result [dB(μV/m)]	Limit [dB(μV/m)]	Margin [dB]	Height [cm]	Angle [°]
1	19840.332	31.9	5.5	37.4	54.0	16.6	294.3	13.9

[BDR(DH5)/2402MHz]

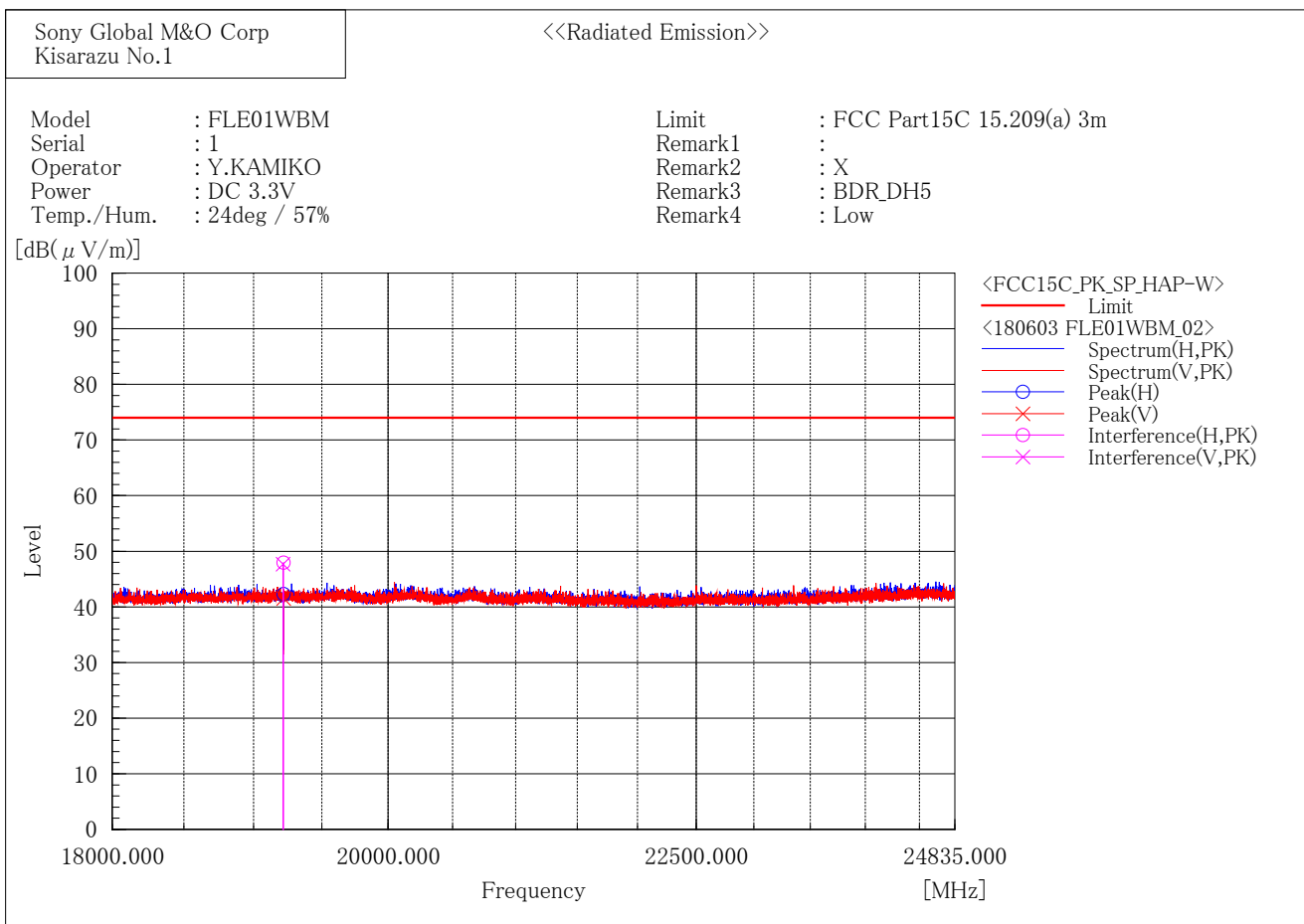

Final Result

--- Horizontal Polarization (PK)---

No.	Frequency [MHz]	Reading [dB(μV)]	c. f [dB(1/m)]	Result [dB(μV/m)]	Limit [dB(μV/m)]	Margin [dB]	Height [cm]	Angle [°]
1	19217.208	42.6	5.4	48.0	74.0	26.0	112.6	269.6

--- Vertical Polarization (PK)---

No.	Frequency [MHz]	Reading [dB(μV)]	c. f [dB(1/m)]	Result [dB(μV/m)]	Limit [dB(μV/m)]	Margin [dB]	Height [cm]	Angle [°]
1	19214.144	42.3	5.4	47.7	74.0	26.3	341.7	311.7

[BDR(DH5)/2441MHz]

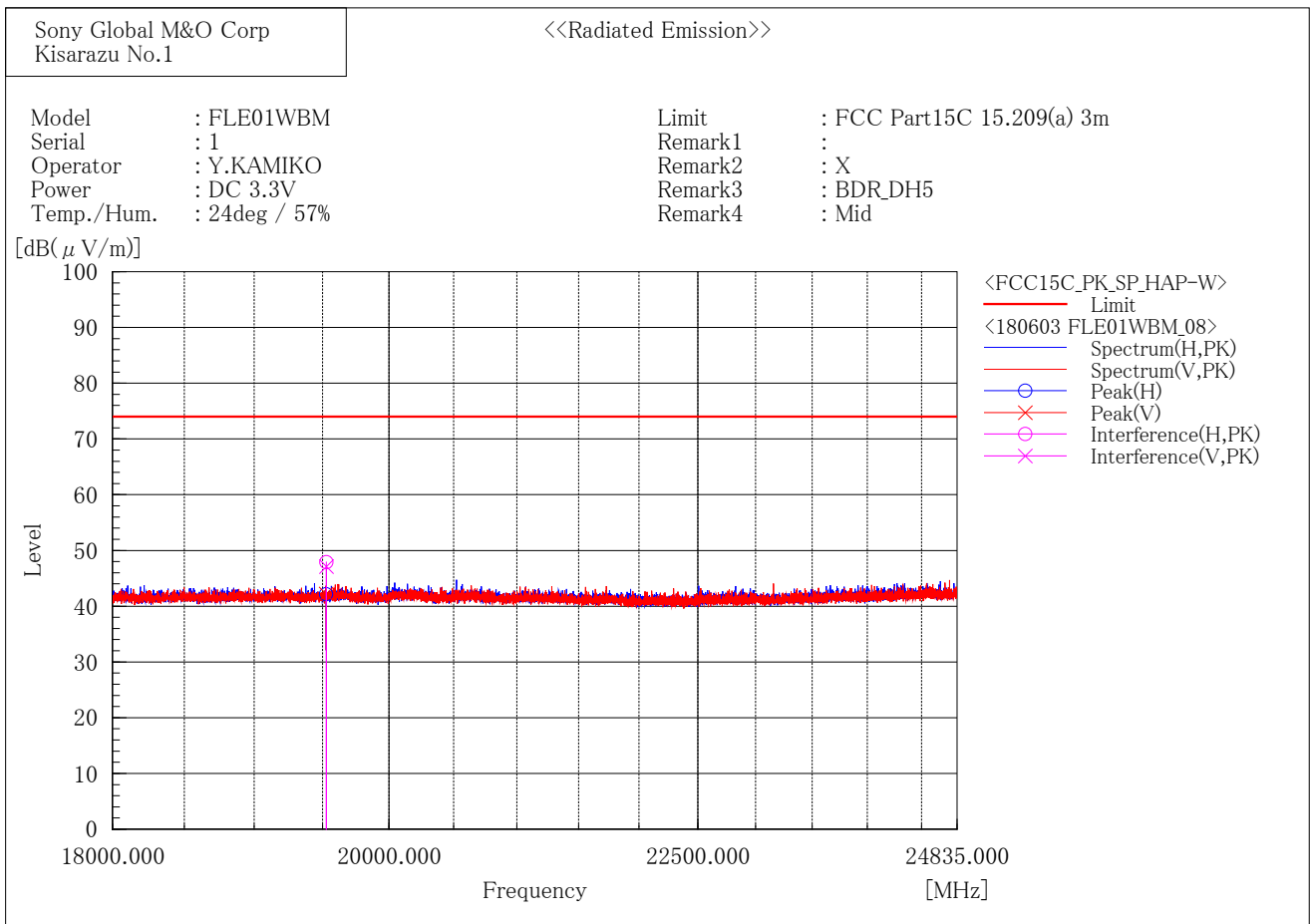

Final Result

--- Horizontal Polarization (PK)---

No.	Frequency [MHz]	Reading [dB(μV)]	c. f [dB(1/m)]	Result [dB(μV/m)]	Limit [dB(μV/m)]	Margin [dB]	Height [cm]	Angle [°]
1	19528.028	42.4	5.5	47.9	74.0	26.1	206.6	93.6

--- Vertical Polarization (PK)---

No.	Frequency [MHz]	Reading [dB(μV)]	c. f [dB(1/m)]	Result [dB(μV/m)]	Limit [dB(μV/m)]	Margin [dB]	Height [cm]	Angle [°]
1	19527.884	41.6	5.5	47.1	74.0	26.9	295.5	313.9

[BDR(DH5)/2480MHz]

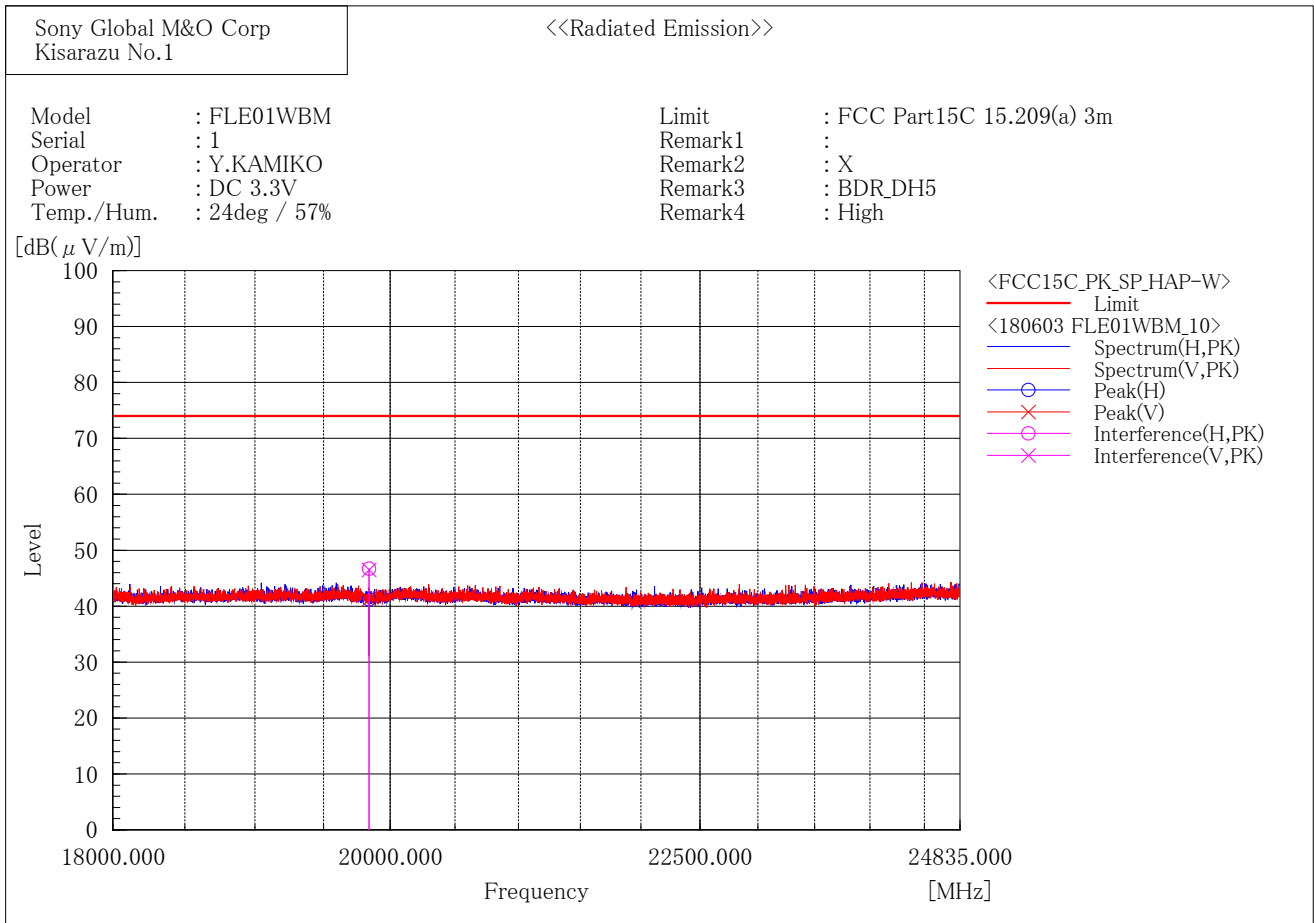

Final Result

--- Horizontal Polarization (PK)---

No.	Frequency [MHz]	Reading [dB(μV)]	c. f [dB(1/m)]	Result [dB(μV/m)]	Limit [dB(μV/m)]	Margin [dB]	Height [cm]	Angle [°]
1	19840.882	41.2	5.5	46.7	74.0	27.3	244.7	158.9

--- Vertical Polarization (PK)---

No.	Frequency [MHz]	Reading [dB(μV)]	c. f [dB(1/m)]	Result [dB(μV/m)]	Limit [dB(μV/m)]	Margin [dB]	Height [cm]	Angle [°]
1	19839.722	41.0	5.5	46.5	74.0	27.5	294.3	13.9

[EDR(3DH5)/2402MHz]

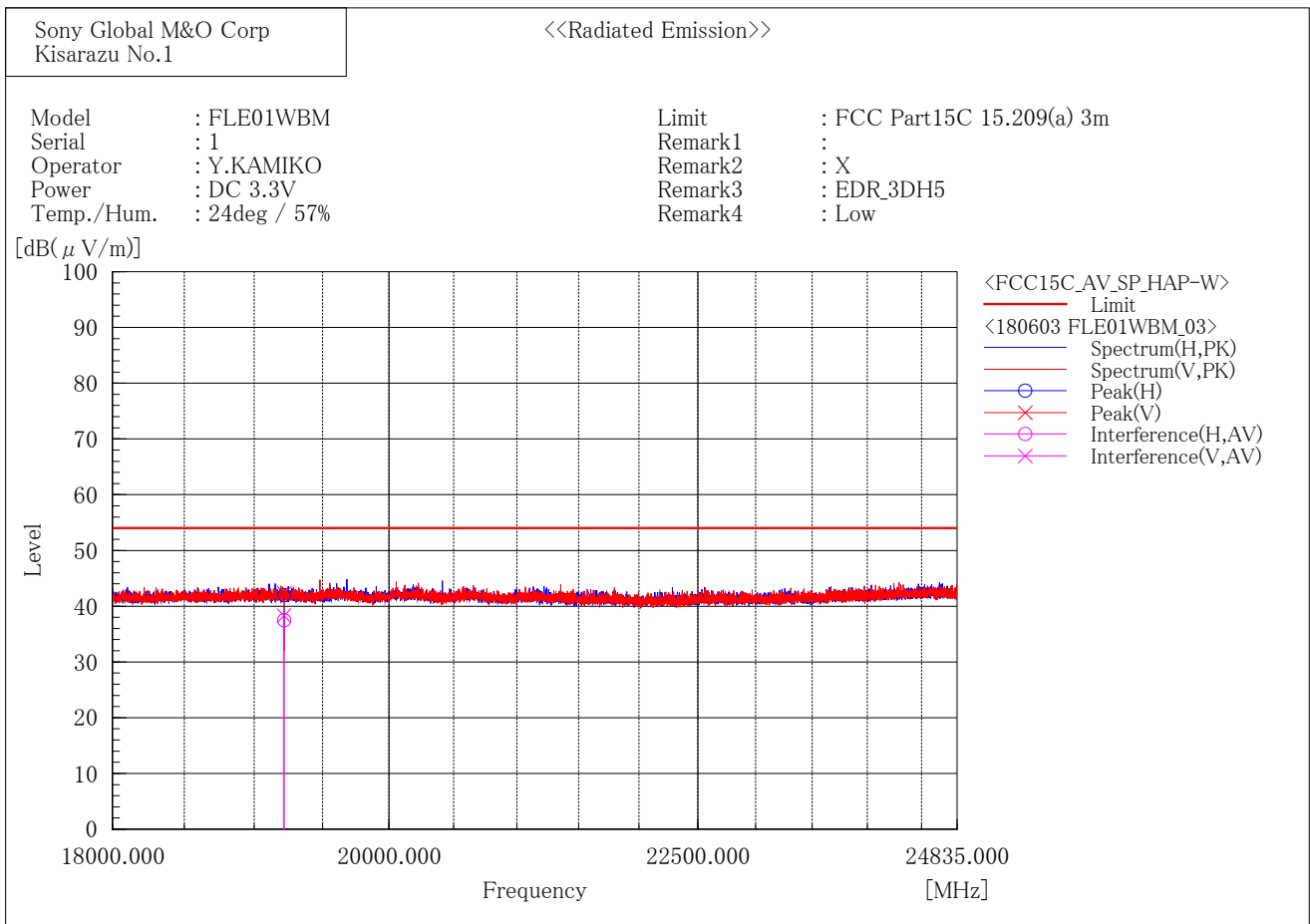

Final Result

--- Horizontal Polarization (AV)---

No.	Frequency [MHz]	Reading [dB(μV)]	c. f [dB(1/m)]	Result [dB(μV/m)]	Limit [dB(μV/m)]	Margin [dB]	Height [cm]	Angle [°]
1	19217.036	32.1	5.4	37.5	54.0	16.5	128.1	152.9

--- Vertical Polarization (AV)---

No.	Frequency [MHz]	Reading [dB(μV)]	c. f [dB(1/m)]	Result [dB(μV/m)]	Limit [dB(μV/m)]	Margin [dB]	Height [cm]	Angle [°]
1	19216.452	32.9	5.4	38.3	54.0	15.7	120.7	127.2

[EDR(3DH5)/2441MHz]

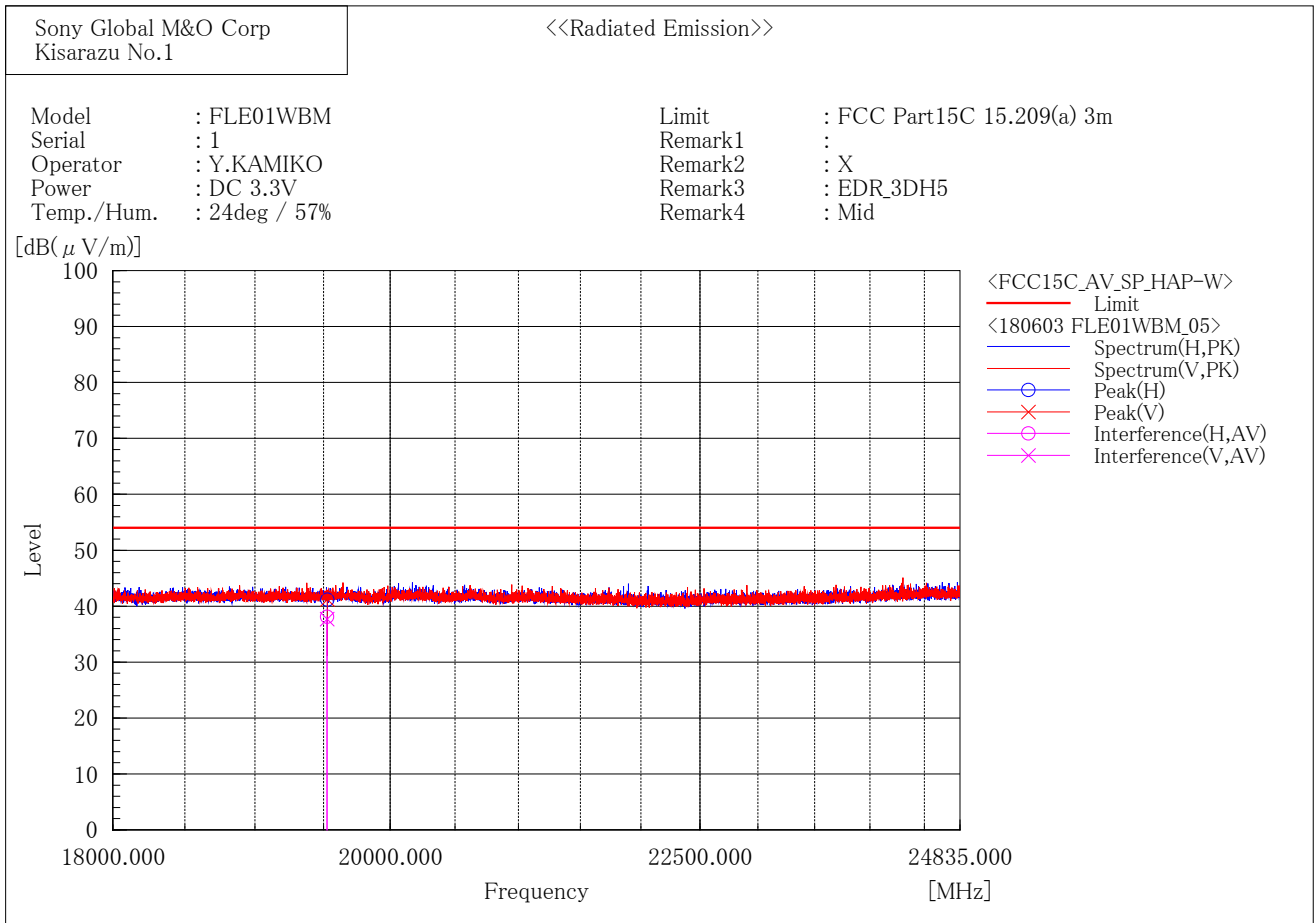

Final Result

--- Horizontal Polarization (AV)---

No.	Frequency [MHz]	Reading [dB(μV)]	c. f [dB(1/m)]	Result [dB(μV/m)]	Limit [dB(μV/m)]	Margin [dB]	Height [cm]	Angle [°]
1	19526.694	32.6	5.5	38.1	54.0	15.9	239.6	329.0

--- Vertical Polarization (AV)---

No.	Frequency [MHz]	Reading [dB(μV)]	c. f [dB(1/m)]	Result [dB(μV/m)]	Limit [dB(μV/m)]	Margin [dB]	Height [cm]	Angle [°]
1	19526.960	32.2	5.5	37.7	54.0	16.3	141.4	248.0

[EDR(3DH5)/2480MHz]

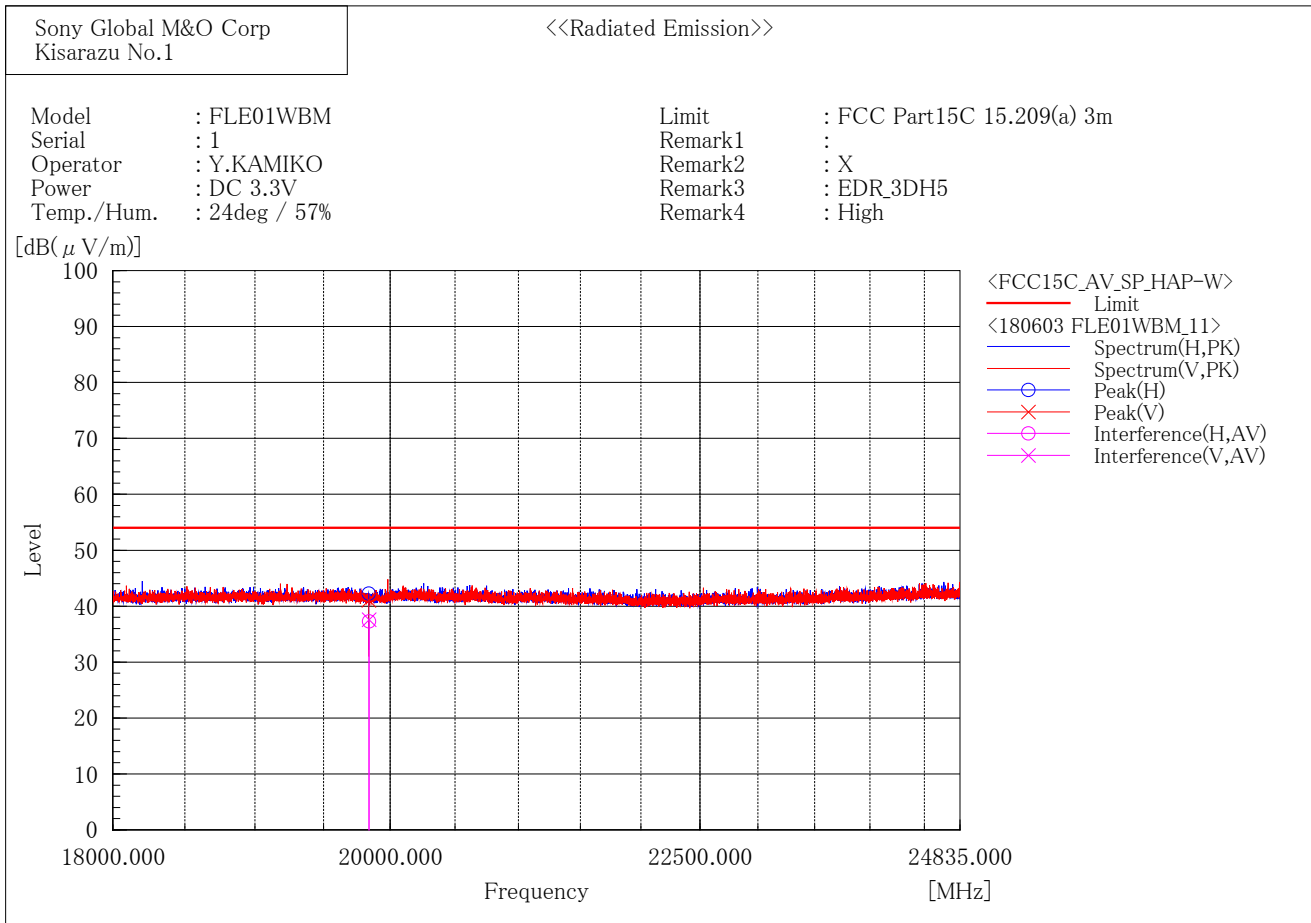

Final Result

--- Horizontal Polarization (AV)---

No.	Frequency [MHz]	Reading [dB(μV)]	c. f [dB(1/m)]	Result [dB(μV/m)]	Limit [dB(μV/m)]	Margin [dB]	Height [cm]	Angle [°]
1	19840.834	31.8	5.5	37.3	54.0	16.7	320.1	62.9

--- Vertical Polarization (AV)---

No.	Frequency [MHz]	Reading [dB(μV)]	c. f [dB(1/m)]	Result [dB(μV/m)]	Limit [dB(μV/m)]	Margin [dB]	Height [cm]	Angle [°]
1	19839.754	32.1	5.5	37.6	54.0	16.4	100.0	62.9

[EDR(3DH5)/2402MHz]

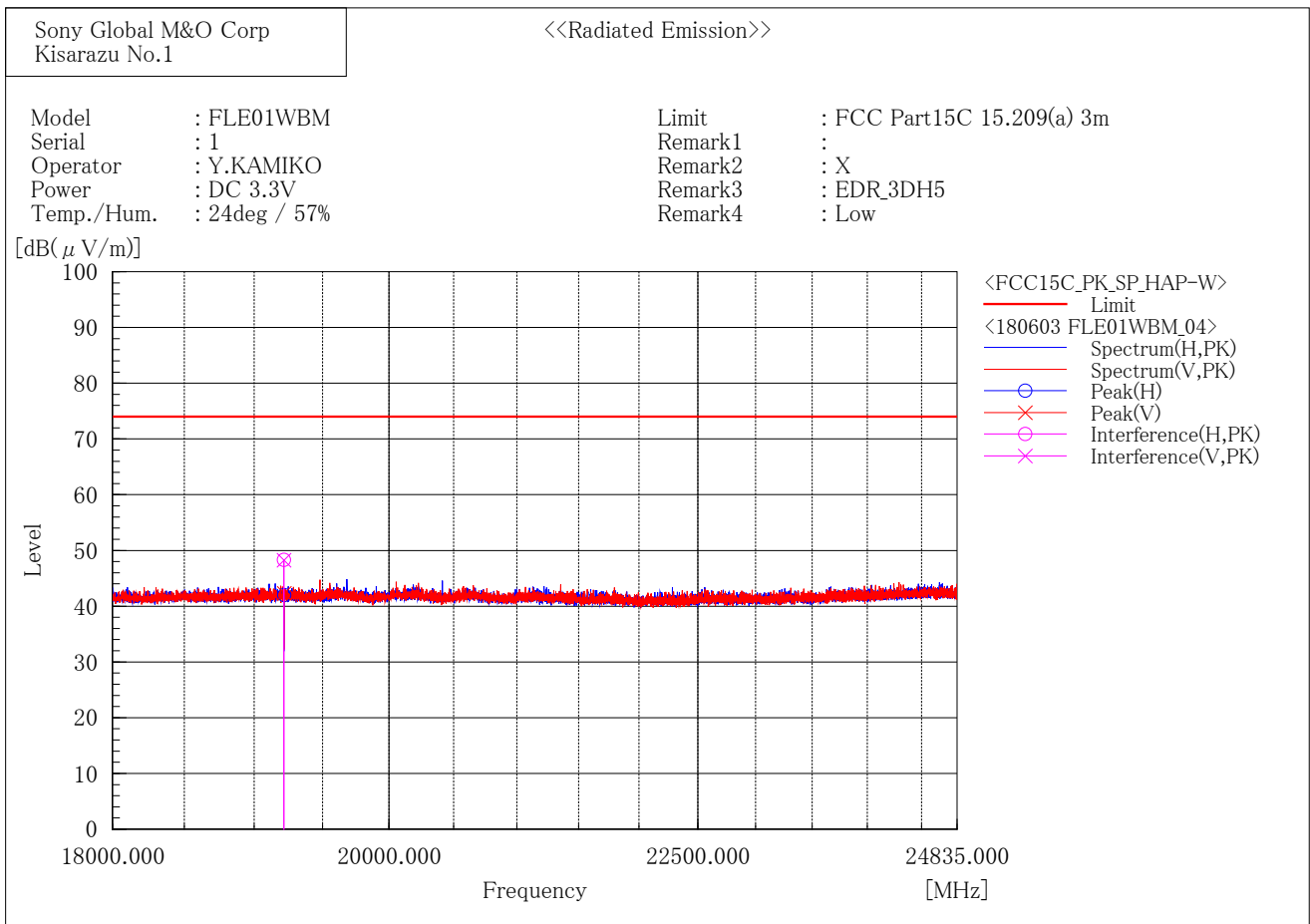

Final Result

--- Horizontal Polarization (PK)---

No.	Frequency [MHz]	Reading [dB(μV)]	c. f [dB(1/m)]	Result [dB(μV/m)]	Limit [dB(μV/m)]	Margin [dB]	Height [cm]	Angle [°]
1	19216.220	42.9	5.4	48.3	74.0	25.7	128.1	152.9

--- Vertical Polarization (PK)---

No.	Frequency [MHz]	Reading [dB(μV)]	c. f [dB(1/m)]	Result [dB(μV/m)]	Limit [dB(μV/m)]	Margin [dB]	Height [cm]	Angle [°]
1	19215.114	42.9	5.4	48.3	74.0	25.7	120.7	129.2

[EDR(3DH5)/2441MHz]

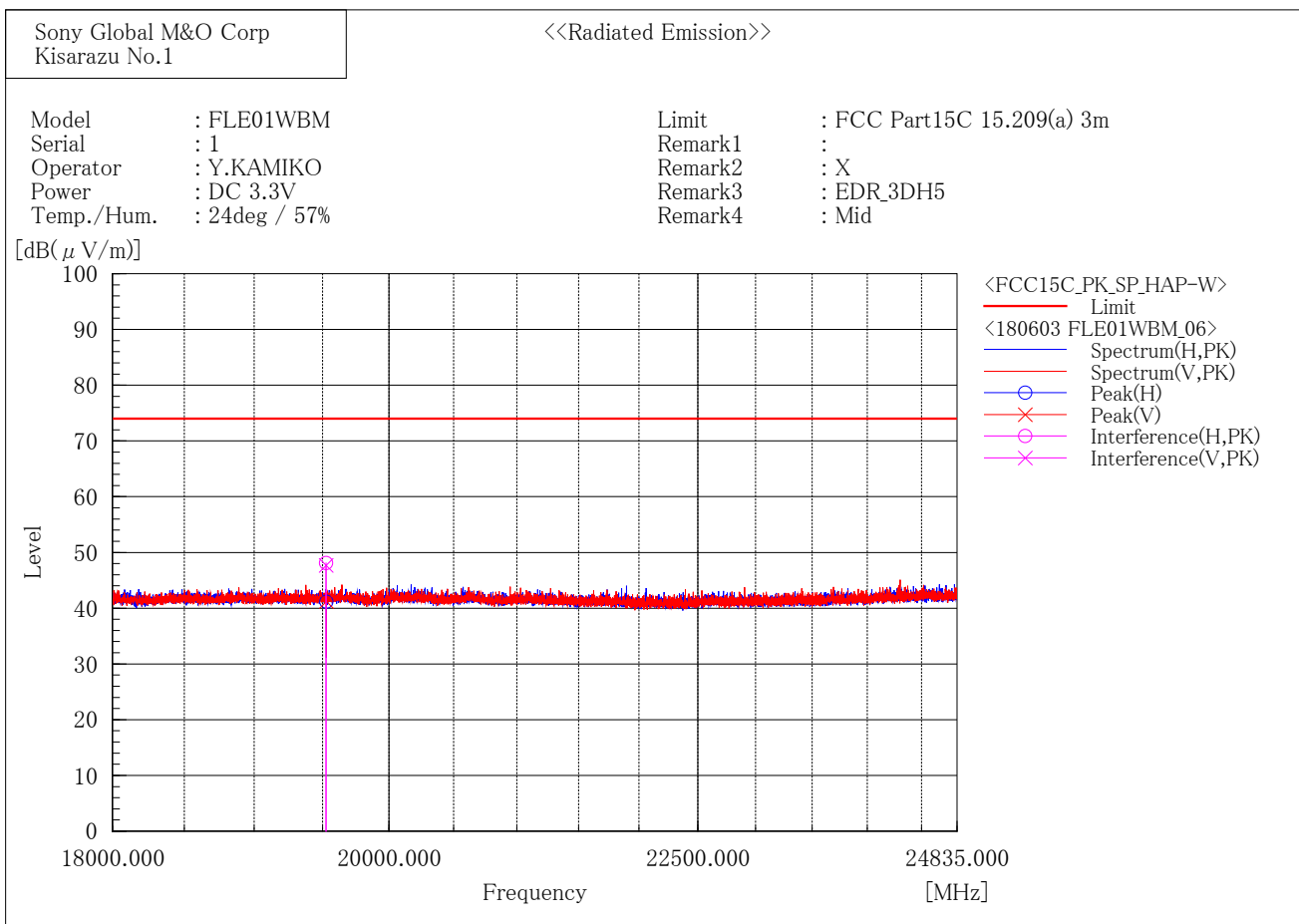

Final Result

--- Horizontal Polarization (PK)---

No.	Frequency [MHz]	Reading [dB(μV)]	c. f [dB(1/m)]	Result [dB(μV/m)]	Limit [dB(μV/m)]	Margin [dB]	Height [cm]	Angle [°]
1	19526.258	42.6	5.5	48.1	74.0	25.9	239.6	326.9

--- Vertical Polarization (PK)---

No.	Frequency [MHz]	Reading [dB(μV)]	c. f [dB(1/m)]	Result [dB(μV/m)]	Limit [dB(μV/m)]	Margin [dB]	Height [cm]	Angle [°]
1	19526.720	42.2	5.5	47.7	74.0	26.3	141.4	248.0

[EDR(3DH5)/2480MHz]

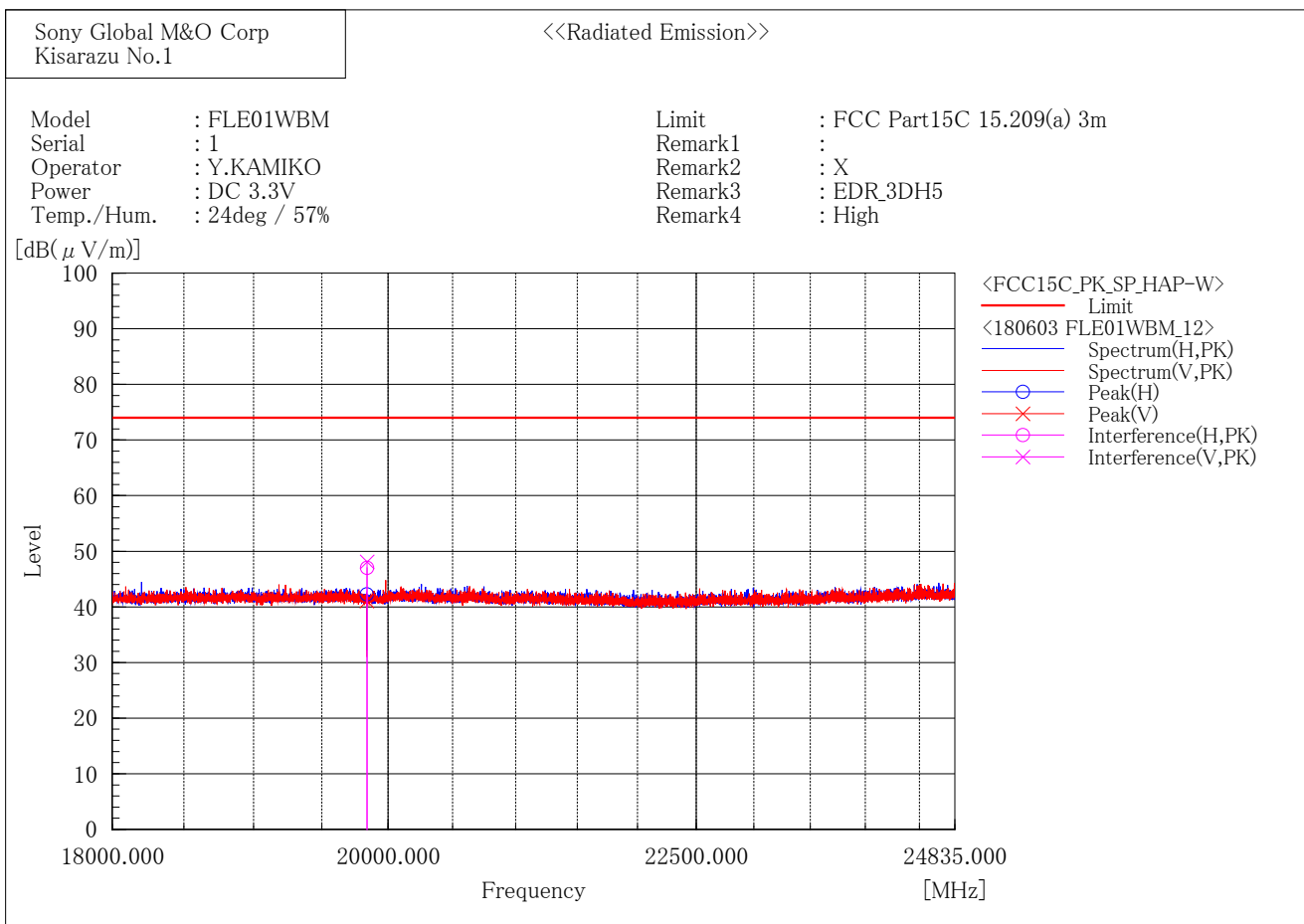

Final Result

--- Horizontal Polarization (PK)---

No.	Frequency [MHz]	Reading [dB(μV)]	c. f [dB(1/m)]	Result [dB(μV/m)]	Limit [dB(μV/m)]	Margin [dB]	Height [cm]	Angle [°]
1	19840.778	41.5	5.5	47.0	74.0	27.0	320.1	62.9

--- Vertical Polarization (PK)---

No.	Frequency [MHz]	Reading [dB(μV)]	c. f [dB(1/m)]	Result [dB(μV/m)]	Limit [dB(μV/m)]	Margin [dB]	Height [cm]	Angle [°]
1	19841.010	42.6	5.5	48.1	74.0	25.9	100.0	62.9

2.4GHz Restricted-Band Edge (Plot data)

These plot data show peak (trace blue) and average (trace black) spectrum for worst case emissions in the restricted-band edges. (Restricted band edges: below 2390MHz and above 2483.5MHz)
The result of the final radiated emissions measurement refers in previous pages.

[BDR / 2402MHz]
Horizontal

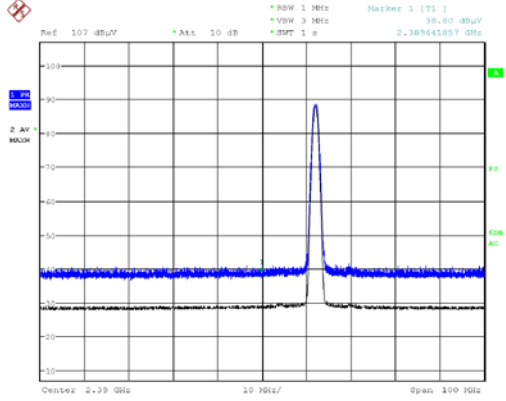

Date: 18_JUL.2018 15:13:39

Vertical

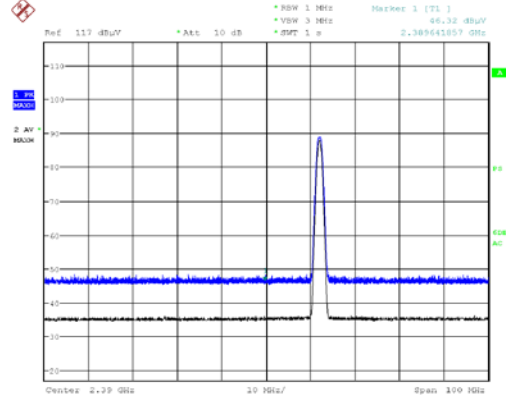

Date: 18_JUL.2018 15:12:04

[BDR / 2480MHz]
Horizontal

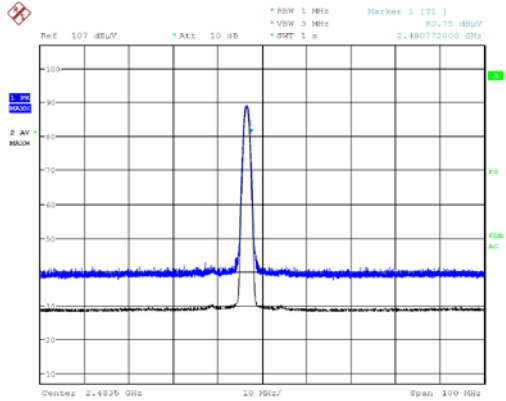

Date: 18_JUL.2018 17:50:00

Vertical

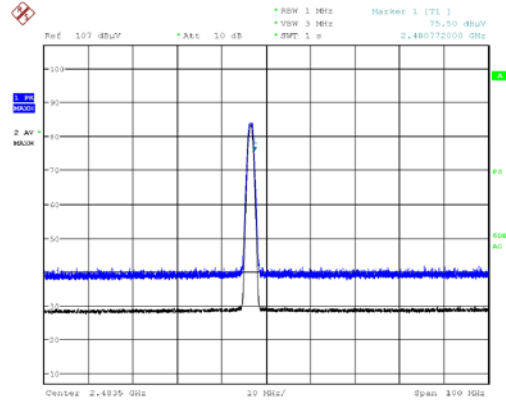

Date: 18_JUL.2018 17:47:34

[EDR / 2402MHz]
Horizontal

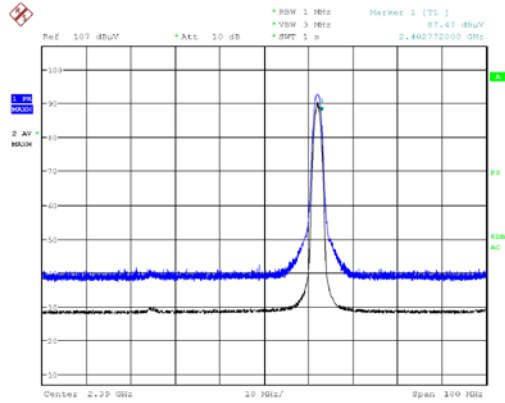

Date: 18.JUL.2018 19:54:23

Vertical

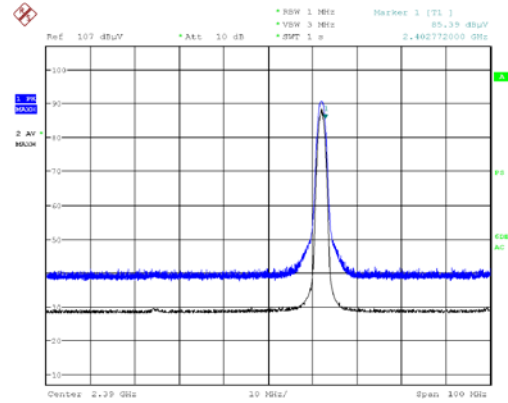

Date: 18.JUL.2018 19:56:38

[EDR / 2480MHz]
Horizontal

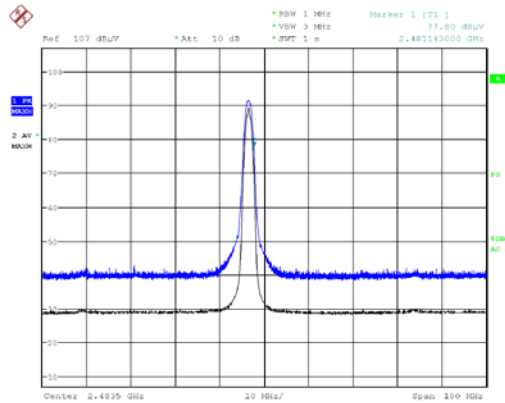

Date: 18.JUL.2018 21:38:05

Vertical

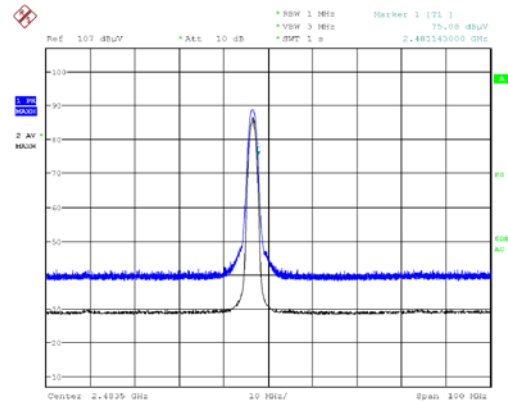

Date: 18.JUL.2018 21:41:42

3.8. Conducted Spurious Emissions for Band Edge

- 1) Ambient temperature : 24.9 deg.C
- 2) Relative humidity : 63.6 %
- 3) Date of measurement : May 31, 2018
- 4) Measured by : M.KOUGA
- 5) Operating mode : Transmitting mode

Mode		Channel [MHz]	Frequency [MHz]	Reading(PK) [dBm]	C.F. [dB]	Result(PK) [dBm]	Limit [dBm]	Margin [dB]
BDR	DH5	2402	2402.15	-1.91	0.87	-1.04	-	-
			2394.27	-61.82	0.87	-60.95	-21.04	39.91
EDR	3DH5	2402	2402.16	-0.70	0.87	0.17	-	-
			2399.63	-50.08	0.87	-49.21	-19.83	29.38

[BDR]

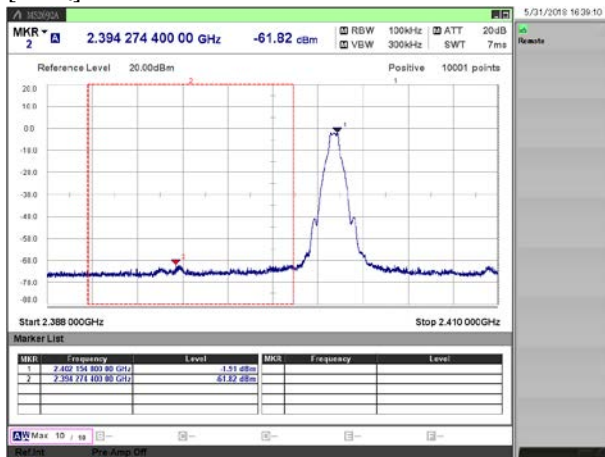

[EDR]

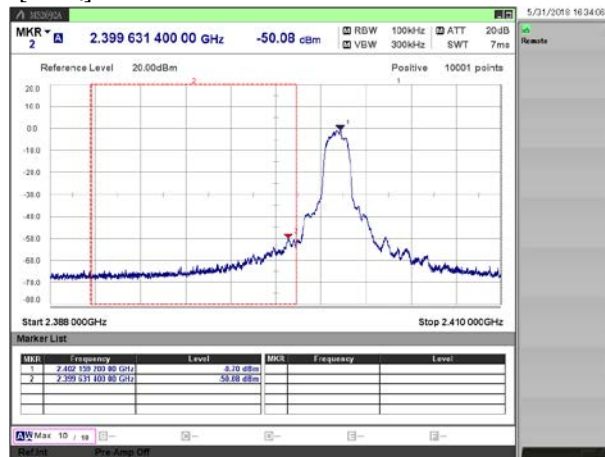

4. Method of Calculation

4.1. AC Power-line Conducted Emissions Measurement

Method of calculation : Software
 The Software for Calculation Name : EP5/ CE
 Version : Ver5.0.0

$$\text{Test Result [dBuV]} = \text{Meter Reading [dBuV]} + \text{C.F. [dB]}$$

Notes :

- (a) Meter Reading : Reading of the EMI test receiver.
- (b) C.F. : System Loss + Correction Factor of LISN

4.2. Time of Occupancy (Dwell Time) Measurement

Method of calculation : Software
 The Software for Calculation Name : SW-308
 Version : Ver.3.3

$$\text{Test Result [msec]} = \text{Dwell Time [msec]} * \text{Cycle [time]} * 31.6 [\text{sec}] / \text{Sweep Time [sec]}$$

Notes :

- (a) Dwell Time : Transmission duration of 1 hopping.
- (b) Cycle : Number of hopping appearances on the spectrum analyzer.
(The average of 5 measurements if it is random hopping equipment)
- (c) 31.6 : $0.4 [\text{sec}] * \text{Number of Hopping Frequencies}(79)$
- (d) Sweep Time : Sweep time settings on the spectrum analyzer.

4.3. Maximum Peak Conducted Output Power Measurement

Method of calculation : Software
 The Software for Calculation Name : SW-308
 Version : Ver.3.3

$$\text{Test Result [dBm]} = \text{Meter Reading [dBm]} + \text{C.F. [dB]}$$

$$\text{Duty Cycle [\%]} = \text{Tx ON Time} / (\text{Tx ON Time} + \text{Tx OFF Time}) * 100$$

Notes :

- (a) Meter Reading : Reading of the spectrum analyzer.
- (b) C.F. : System Cable Loss + EUT Cable Loss

4.4. Radiated Spurious Emission Measurement

Method of calculation : Software
The Software for Calculation Name : V-Scan
Version : Ver.4.0.30

$$\text{Test Result [dBuV/m]} = \text{Meter Reading [dBuV]} + \text{C.F. [dB/m]}$$

Notes :

- (a) Meter Reading : Reading of the EMI test receiver or spectrum analyzer.
(b) C.F. : Antenna Factor (including Balun Loss) + System GainLoss
: Antenna Factor (including Balun Loss) + System GainLoss + 20 log (3 m/ 10 m)

4.5. Conducted Spurious Emission for Band Edge Measurement

Method of calculation : Software
The Software for Calculation Name : SW-308
Version : Ver.3.3

$$\text{Test Result [dBm]} = \text{Meter Reading [dBm]} + \text{C.F. [dB]}$$

Notes :

- (a) Meter Reading : Reading of the spectrum analyzer.
(b) C.F. : System Cable Loss + EUT Cable Loss

5. List of Test Equipment

All test results are traceable to the national and/or international standards.

5.1. AC Power-line Conducted Emissions

4th Site Shielded Room

	Ctrl#	Equipment	Model No.	Serial No.	Manufacturer	Cal.Interval	Last Cal.
x	-	Shield Room	-	-	TDK	-	-
x	M0575	EMI Receiver	ESCI	100161	Rohde & Schwarz	12 months	18.04.18
x	CS0043	4th Site CE Cable SYSTEM	-	-	EMC/RF Test Lab.	12 months	18.06.01
x	M0664	6dB Attenuator	6806.01A	N/A	HUBER+SUHNER AG	12 months	18.06.01
x	M0619	HIGH FREQUENCY FUSE	MP612A	N/A	Anritsu	12 months	18.06.01
x	M0514	LISN	ENV216	100424	Rohde & Schwarz	12 months	18.04.17
x	M0505	LISN	ENV216	100425	Rohde & Schwarz	12 months	18.04.17
-	M2289	LISN	KNW-407	8-1182-12	Kyoritsu	12 months	18.04.23
-	M2290	LISN	KNW-242C	8-1183-1	Kyoritsu	12 months	18.04.23
x	M0153	50 ohm Terminator	CT-01	N/A	TME	12 months	17.12.04
-	M0597	50 ohm Terminator	CT-01	N/A	TME	12 months	17.12.04
-	M2292	50 ohm Terminator	T1302	N/A	Stack	12 months	18.04.23
-	M2293	50 ohm Terminator	T1302	N/A	Stack	12 months	18.04.23
x	M0690	Thermometer	AD-5640A	201304	AND	12 months	17.11.14

5.2. Antenna-port Conducted Measurements

4th Site Shielded Room 1

	Ctrl#	Equipment	Model No.	Serial No.	Manufacturer	Cal.Interval	Last Cal.
x	-	Shield Room	B83117-B2432-T161	P26428	Albatross Project	-	-
-	W0140	Spectrum Analyzer	FSU26	200717	Rohde & Schwarz	12 months	17.08.25
x	W0100	Spectrum Analyzer	MS2692A	6201338954	Anritsu	12 months	18.04.03
x	W0006	Power Meter	N1911A	MY50000295	Keysight Technologies	12 months	17.10.10
x	W0007	Power Sensor	N1922A	MY50180022	Keysight Technologies	12 months	17.10.10
-	W0029	10dB Attenuator	8493C	76549	Keysight Technologies	12 months	17.08.01
-	WC0002	RF Cable	SUCOFLEX 102	34124/2	HUBER + SUHNER	12 months	17.08.03
-	WC0003	RF Cable	SUCOFLEX 102	34127/2	HUBER + SUHNER	12 months	17.08.03
-	WC0004	RF Cable	SUCOFLEX 102	34288/2	HUBER + SUHNER	12 months	17.08.03
x	WC0005	RF Cable	SUCOFLEX 102	34287/2	HUBER + SUHNER	12 months	17.08.03
-	WC0006	RF Cable	SUCOFLEX 102	34289/2	HUBER + SUHNER	12 months	17.08.03
-	WC0007	RF Cable	SUCOFLEX 102	34286/2	HUBER + SUHNER	12 months	17.08.03
x	M0720	Thermometer	TH-321	140036	AS ONE	12 months	18.07.20

5.3. Radiated Spurious Emissions

EMC Site 3m Semi-Anechoic Chamber

	Ctrl.#	Equipment	Model No.	Serial No.	Manufacturer	Cal.Int.	Last Cal.
x	M0115	Semi-Anechoic Chamber	-	7D1-8A11	Otsuka Science	12	18.06.02
x	M0686	EMI Receiver	N9038A	MY52260113	Keysight Technologies	12	17.11.20
x	M0562	EMI Receiver	ESU26	100068	Rohde & Schwarz	12	18.07.09
x	M0959	EMI Receiver	ESU40	100041	Rohde & Schwarz	12	18.01.31
x	A0073	Loop Antenna	HFH2-Z2	100171	Rohde & Schwarz	12	17.11.01
x	A0089	Biconical Antenna	BBA9106	VHA91032835	Schwarzbeck	12	17.12.15
x	A0088	Log periodic Antenna	UHALP9108A1	0649	Schwarzbeck	12	17.12.15
x	A0064	Horn Antenna	BBHA9120D	746	Schwarzbeck	12	17.11.18
x	A0078	Horn Antenna	HAP06-18W	00000070	TOYO Corporation	12	17.11.18
x	A0058	Horn Antenna	HAP18-26W	00000016	TOYO Corporation	12	17.12.01
x	CS0017	N-RE Cable SYSTEM 1	-	-	EMC/RF Test Lab.	12	17.11.17
x	CS0018	N-RE Cable SYSTEM 2	-	-	EMC/RF Test Lab.	12	17.11.17
x	CS0045	N-3m EMF Cable SYSTEM	-	-	EMC/RF Test Lab.	12	17.11.17
x	CS0074/0075	N-RE Cable SYSTEM 4	-	-	EMC/RF Test Lab.	12	17.11.17
x	M0126	Step Attenuator	8494H	3837M01144	Keysight Technologies	12	18.06.02
x	M0752	Pre Amplifier	310N	320621	SONOMA INSTRUMENT	12	17.11.17
x	M0128	3dB Attenuator	8491A	53541	Keysight Technologies	12	17.11.17
x	M0609	3dB Attenuator	8491B	MY39265960	Keysight Technologies	12	17.11.17
x	M0737	GHz Filter Box	FB-G1	001	Sony Global M&O	12	17.11.17
x	M0687	Thermo Meter	AD-5640A	201301	A&D	12	17.10.06

About calibration interval

Valid until the end of the month listed in "Cal. Int." column.