

SONY

## Remote Controller

### Operating Instructions



REMOTE-TEST

Printed in Japan  
©2021 Sony Group Corporation

## Safety Information



- A damaged power cord may cause a fire or electric shock. Observe the following cautions to avoid damaging the power cord.
  - Do not pinch the power cord between the unit and a table, wall, or other object.
  - Do not modify or damage the power cord.
  - Do not place heavy objects on the power cord or pull on the power cord.
  - Keep the power cord away from heaters and other heat sources.
  - When you disconnect the power cord, always hold it by the plug.
- Do not wrap the power cord or connection cables around the AC adapter. This may cause the cord or cables to break.
- Disconnect the power cord and connection cables before moving the product. Otherwise, the power cord and connection cables may be damaged, resulting in a fire or electric shock, or connected equipment may fall or topple over, causing injuries.  
Also, take care not to drop the product.
- For safety reasons, if the product is not to be used for long periods, unplug it from the wall outlet.
- Do not place or store the product in a location exposed to direct sunlight or close to a heater. We recommend storing the product at an ambient temperature of 18 °C (64 °F) to 30 °C (86 °F).
- Do not let water or foreign objects get inside the unit. This may cause a fire or electric shock. If water or foreign objects get inside the unit, turn it off immediately, and disconnect the power cord and connection cables.
- Do not disassemble the product. Disassembly or modification of the unit and the included AC adapter or power cord may cause a fire or electric shock.
- Use only the included AC adapter. Use of a different AC adapter may cause a fire, electric shock, or malfunction.
- Do not use the product if there is a possibility of lightning strike. A lightning strike may cause an electric shock. If lightning is likely, unplug the product from the wall outlet to prevent a fire, electric shock, or product failure.
- Use the included power cord. The included power cord is for use exclusively with this unit, and cannot be used with other products.  
Also, use only the included power cord with the unit. Use of a different power cord may generate heat, causing a fire or electric shock.
- Do not use the unit with the air inlet/vent of the unit blocked or with the unit or AC adapter covered by a cloth or other object. Heat will build up and may cause product failure. Turn off the unit before placing it in a bag, etc.
- Turn off the power and unplug the product from the wall outlet before cleaning it with a dry cloth. If the product is cleaned with the power connected, this may cause an electric shock.
- Firmly connect the connectors.
  - Do not insert metal objects into the connector ports. This may short-circuit the pins and cause a fire.
  - Insert the connectors straight into the ports. If the connectors are inserted at an angle, the pins may short-circuit, causing a fire.
- Do not place this unit close to medical devices.
  - This unit has magnet(s) which may interfere with pacemakers, programmable shunt valves for hydrocephalus treatment, or other medical devices.
  - Do not place this unit close to persons who use such medical devices. Consult your doctor before using this unit if you use any such medical device.
- This product is designed for use only in the U.S.A.
  - Use with 120 V AC power.
  - Use with other voltages, such as in other countries or regions, may cause a fire or electric shock. Note that the AC adapter and power cord may support different input voltages. Be sure to check the descriptions of the AC adapter and power cord.



- Do not insert foreign objects or other items into the air inlet or the air vent. This may cause product failure or injuries.
- Do not subject the product to strong impacts. If you apply excessive force to the product, such as by putting a heavy object on top of it, dropping it, or stepping on it, this may cause an injury or product failure.
- Keep the product away from infants and young children. If a person accidentally touches the moving parts of the product while it is in operation, this may cause damage to the product or injuries.

### Battery safety

- Be sure to observe the following cautions to avoid heat generation, ignition, rupture, or other hazards.
- This product has a built-in battery.
- Charge the battery only by the method specified by Sony. Please refer to the Startup Guide and Help Guide for the aircraft.
- To reduce the risk of injury or property damage, do not expose the batteries (battery pack or installed batteries) to fire or other heat sources. Also, do not crush or drop the battery pack or battery cell.

## Compliance Information

MPE Statement : for Sector Antenna

This equipment complies with FCC radiation exposure limits set forth for an uncontrolled environment. This equipment should be installed and operated with a minimum distance of 25 cm between the radiator and a human body.

Sector Antenna Specification  
Model Name : 5G-DU-SE-14-16  
Type : Sector  
Impedance : 50ohm  
Dimension : 470 x 175 x 60mm

### SAR Statement : for Patch Antenna

These requirements set a SAR limit of 1.6 W/kg averaged over one gram of tissue. The highest SAR value reported under this standard during product certification is 1.511 W/kg.

Contains FCC ID: AK810022411

This transmitter must not be co-located or operated in conjunction with any other antenna or transmitter except Grant conditions.

You are cautioned that any changes or modifications not expressly approved in this manual could void your authority to operate this equipment.

Supplier's Declaration of Conformity  
Trade Name: SONY  
Model: RCR-VH1  
Responsible Party: Sony Electronics Inc.  
Address: 16535 Via Esprillo, San Diego, CA 92127 U.S.A.  
Telephone Number: 858-942-2230

This device complies with part 15 of the FCC rules. Operation is subject to the following two conditions:

- (1) This device may not cause harmful interference, and
- (2) This device must accept any interference received, including interference that may cause undesired operation.

### Note:

This equipment has been tested and found to comply with the limits for a Class B digital device, pursuant to part 15 of the FCC Rules. These limits are designed to provide reasonable protection against harmful interference in a residential installation. This equipment generates, uses and can radiate radio frequency energy and, if not installed and used in accordance with the instructions, may cause harmful interference to radio communications. However, there is no guarantee that interference will not occur in a particular installation. If this equipment does cause harmful interference to radio or television reception, which can be determined by turning the equipment off and on, the user is encouraged to try to correct the interference by one or more of the following measures:

- Reorient or relocate the receiving antenna.
- Increase the separation between the equipment and receiver.
- Connect the equipment into an outlet on a circuit different from that to which the receiver is connected.
- Consult the dealer or an experienced radio/TV technician for help.

## Notes on Use

- This product is designed for use only in the U.S.A. Operation is not guaranteed when used in other countries or regions.
- Do not connect the AC adapter to an electronic transformer (travel converter). This may cause heat generation or product failure.
- The wireless transmission function of the product is designed for use only in the U.S.A. Use in other countries or regions may be punishable by law.

### Caution when carrying the unit

Carry the unit by the handle bar. The handle bar, control sticks, and mobile device holder may break if excessive force is applied to these parts.

## About the Wireless Transmission Function

### Cautions when using this product

- When using this product to fly an aircraft, turn off the Wi-Fi® and Bluetooth® functions of the tablet or other mobile device mounted on the unit.
- The unit has built-in antennas in a part of the handle bar and a part close to the air vent. Take care not to cover the parts containing the built-in antennas with your hand, cables, or other objects.

## Other Information

### Compatible iPhone/iPad models

- iPhone 11 Pro Max
- iPhone 11 Pro
- iPhone 11
- iPhone XS Max
- iPhone XS
- iPhone XR
- iPhone X
- iPhone 8 Plus
- iPhone 8
- iPhone 7 Plus
- iPhone 7
- iPad Pro 10.5-inch
- iPad Pro 9.7-inch
- iPad Air (3rd generation)
- iPad mini (5th generation)
- iPad (7th generation)
- iPad (6th generation)

### Trademarks and copyrights

- Wi-Fi is registered trademark of Wi-Fi Alliance.
- The Bluetooth® word mark and logos are registered trademarks owned by Bluetooth SIG, Inc. and any use of such marks by Sony Group Corporation and its subsidiaries is under license.
- The terms HDMI and HDMI High-Definition Multimedia Interface, and the HDMI Logo are trademarks or registered trademarks of HDMI Licensing Administrator, Inc. in the United States and other countries.
- Apple®, iPad®, iPad mini®, iPad Air®, iPad Pro® and iPhone® are trademarks of Apple Inc., registered in the U.S. and other countries.
- Use of the Made for Apple badge means that an accessory has been designed to connect specifically to the Apple product(s) identified in the badge and has been certified by the developer to meet Apple performance standards. Apple is not responsible for the operation of this device or its compliance with safety and regulatory standards. Please note that use of this accessory with an Apple product may affect wireless performance.

System and/or product names mentioned in this document are, in general, registered trademarks or trademarks of their respective developers and the "™" and "®" marks are omitted in the text. Furthermore, any copyrights not explicitly mentioned in this document are the property of their respective owners.



### RECYCLING RECHARGEABLE BATTERIES

Rechargeable batteries are recyclable. You can help preserve our environment by returning your used rechargeable batteries to the collection and recycling location nearest you.

For more information regarding recycling of rechargeable batteries, visit [www.sony.com/electronics/eco/environmental-management](http://www.sony.com/electronics/eco/environmental-management)

Caution: Do not handle damaged or leaking rechargeable batteries.



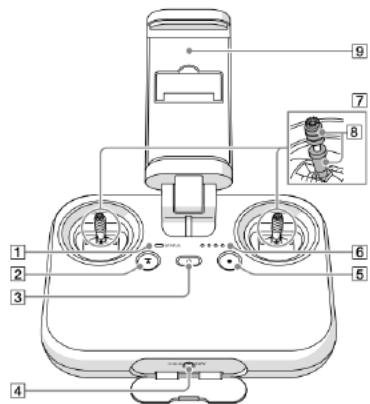

- 1 Status LED
- 2 ▲ (Automated flight pause) button
- 3 ⏻ (Power) button
- 4 Power port
- 5 ● (MOVIE) button
- 6 Battery level LEDs
- 7 Control sticks
- 8 Lever heads
- 9 Mobile device holder

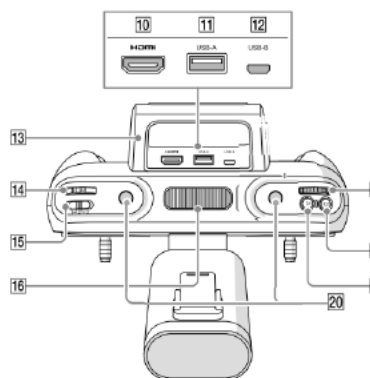

- 10 HDMI port
- 11 USB port (USB-A)
- 12 Micro USB port (USB-B)
- 13 Handle bar
- 14 Control lever
- 15 Flight mode switch
- 16 Air vent
- 17 C1 (Custom 1) button
- 18 C2 (Custom 2) button
- 19 Control dial
- 20 Antenna connectors

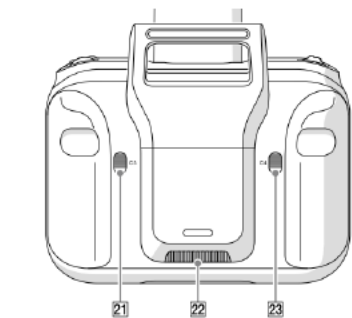

- 21 C3 (Custom 3) button
- 22 Air inlet
- 23 C4 (Custom 4) button

### [1] Attaching a mobile device

On the remote controller, mount the mobile device (tablet or smartphone) on which you have installed the 'Airpeak Flight' app.

- 1 **Extend the mobile device holder.**  
Raise the lever on the back and extend the mobile device holder.



- 2 **Mount and secure the mobile device.**  
Place the mobile device on the mobile device holder, adjust the holder height, and then lower the lever to secure the mobile device.



- 3 **Stabilize the mobile device holder.**  
Tighten the screw at the base of the holder by turning it with a coin or tool.



### [2] Connecting the cable

Connect the cable included with your mobile device or another compatible cable to the remote controller USB port (USB-A) and the mobile device port.

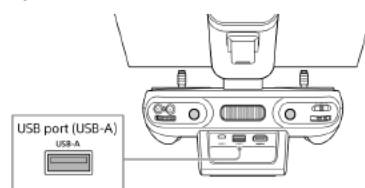

### [3] Connecting the antennas

Connect the supplied antennas to both antenna connectors.  
2 types of antennas can be installed  
APA-M25: Patch antenna  
WLE-HG-SEC(with coaxial cable): Sector Antenna

## Linking/setting up the remote controller and aircraft

Follow the on-screen instructions in the 'Airpeak Flight' app to link the remote controller and aircraft and set up the aircraft.

#### Preparation

- Confirm that the mobile device mounted on the remote controller is connected to the internet.
- Charge the built-in remote controller battery sufficiently (page 17).
- Charge both aircraft battery packs sufficiently (page 17).

- 1 **Turn on the remote controller.**  
Press and hold the ⏻ (Power) button for at least 2 sec. to turn on the power. After startup, the status LED stops flashing and remains on.

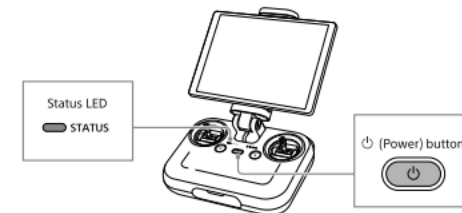

- 2 **Turn on the aircraft.**  
Press and hold the ⏻ (Power) button for at least 2 sec. to turn on the power. After startup, the power status LED stops flashing and remains on.

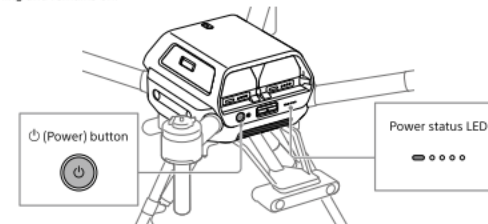

- 3 **Tap [Start link] in the 'Airpeak Flight' app.**  
As you proceed with the [Initial setup] procedure in the 'Airpeak Flight' app, the [Link remote controller to aircraft] screen will be displayed. On this screen, tap [Start link] to initiate the process of linking the remote controller and aircraft.