

1.1.1 Functional Block Diagram

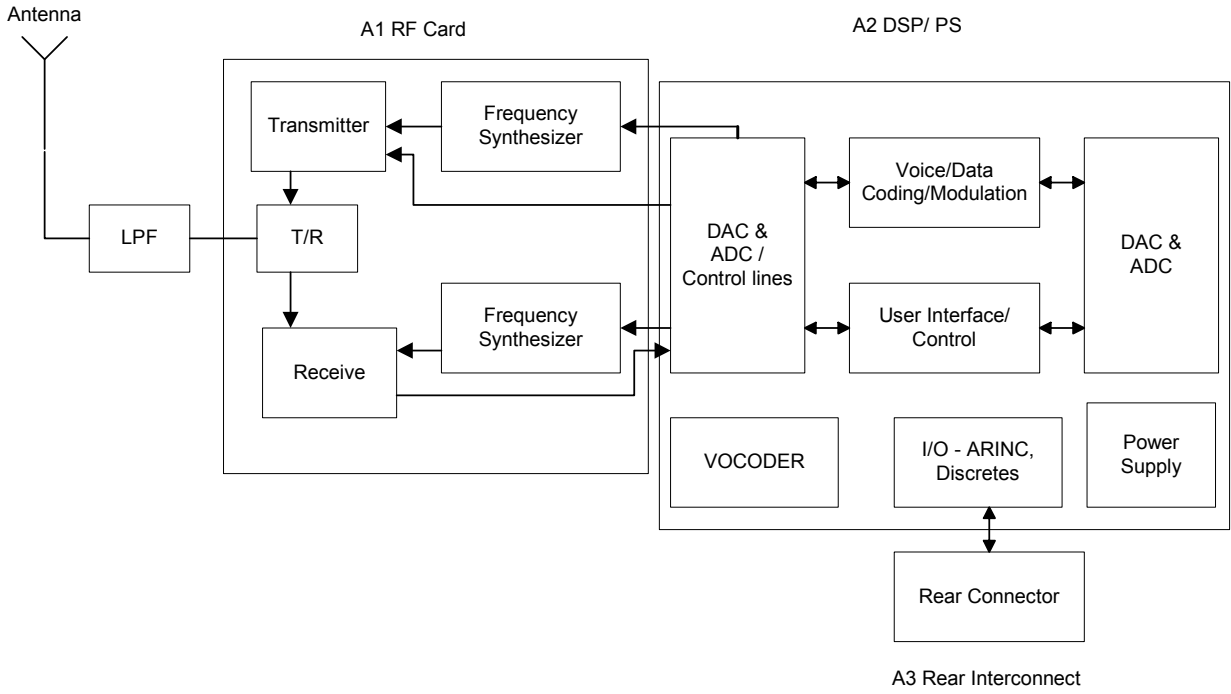

1.1.2 System Interconnect Diagram

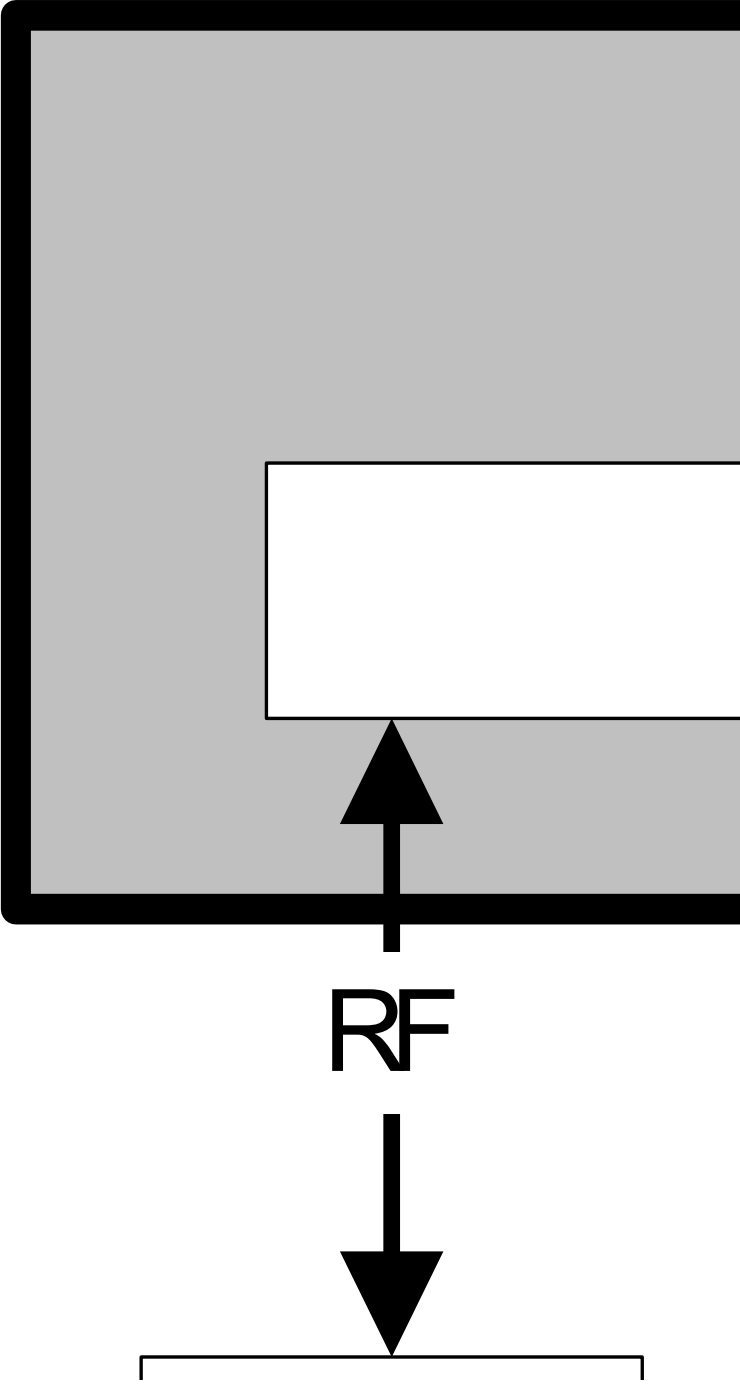

1.1.3 Transmitter Block Diagram

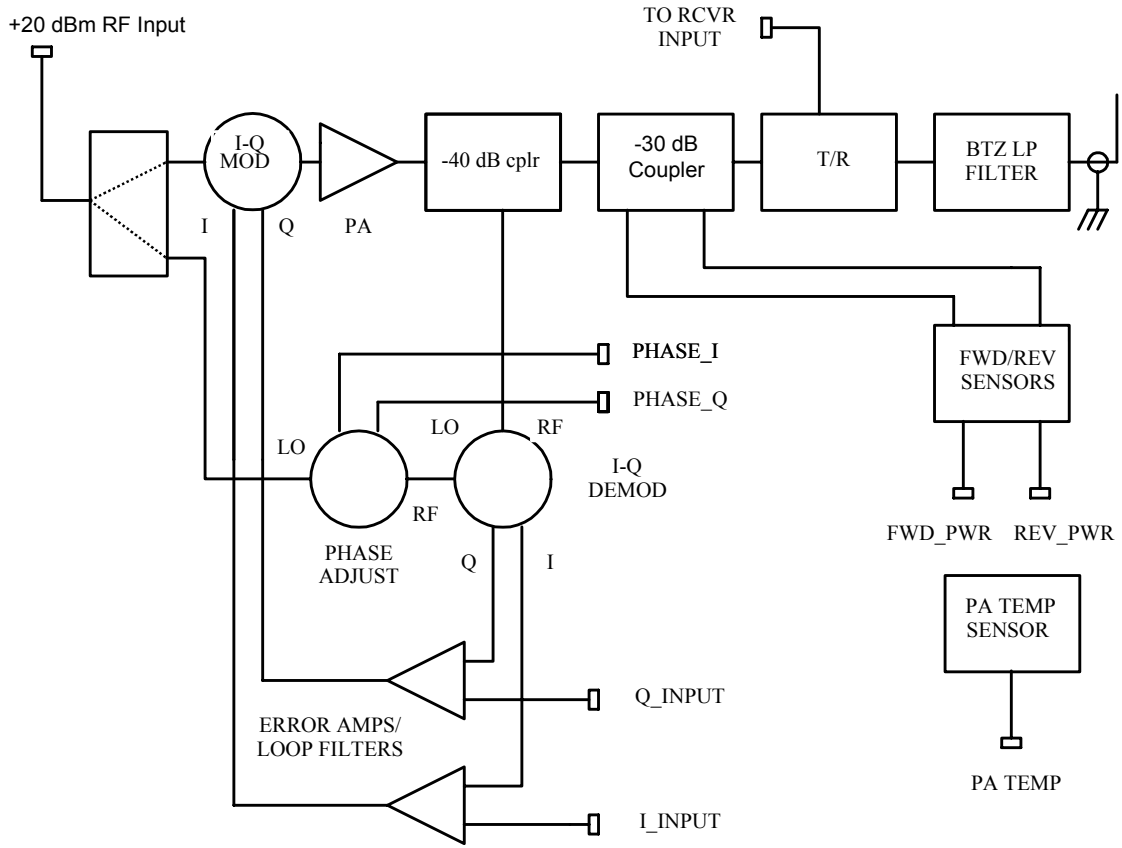

1.1.4 Receiver Block Diagram

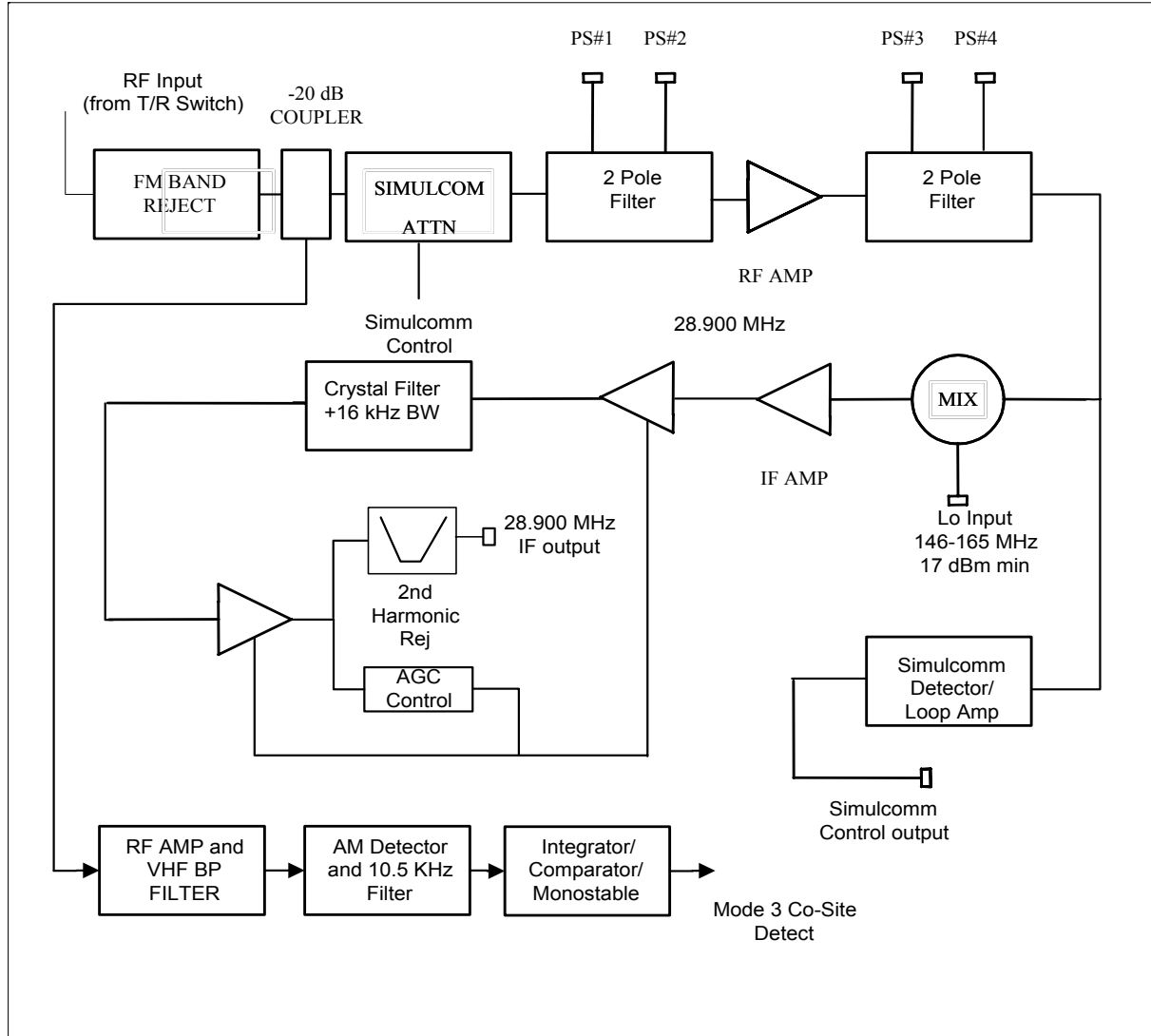

1.1.5 Transmit Synthesizer Block Diagram

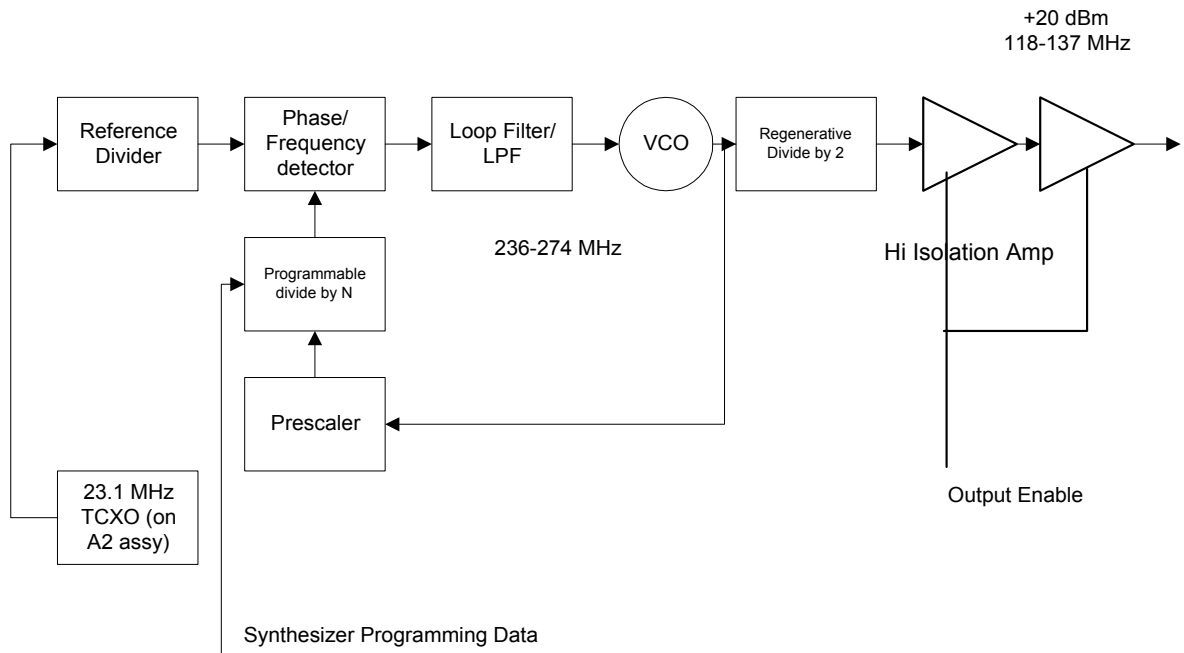

1.1.5.1 Detail of Regenerative Frequency Divider

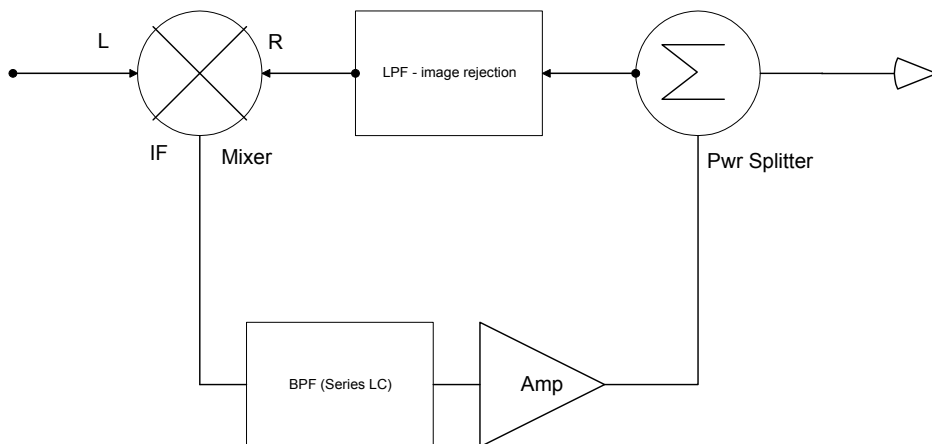

1.1.6 Receiver Synthesizer Block Diagram

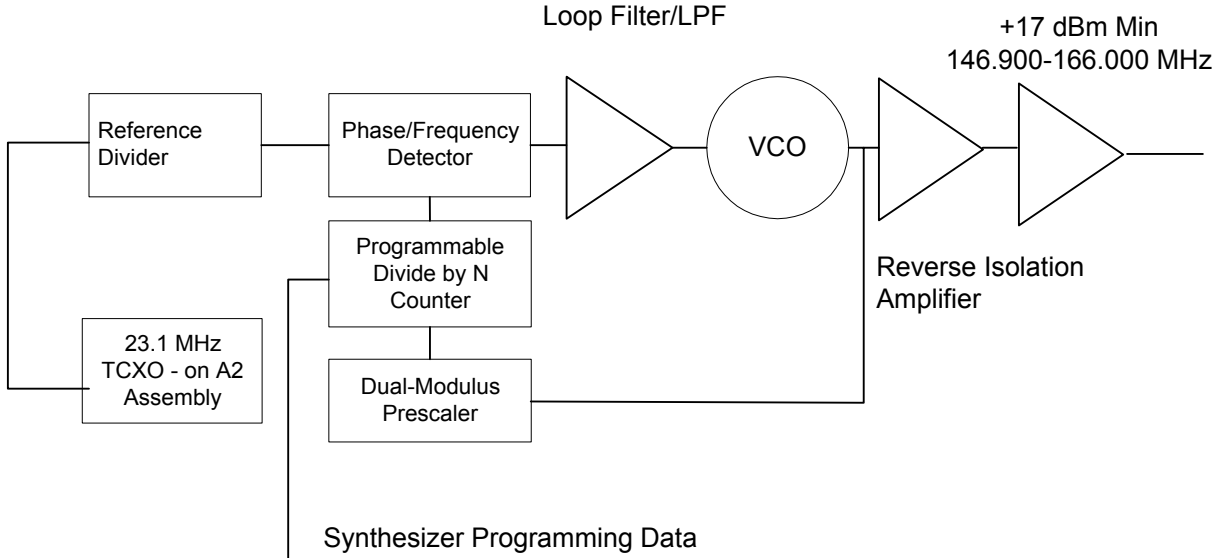

1.1.7 A2 DSP Circuit Card Block Diagram

