

### 1.1.1 Functional Block Diagram

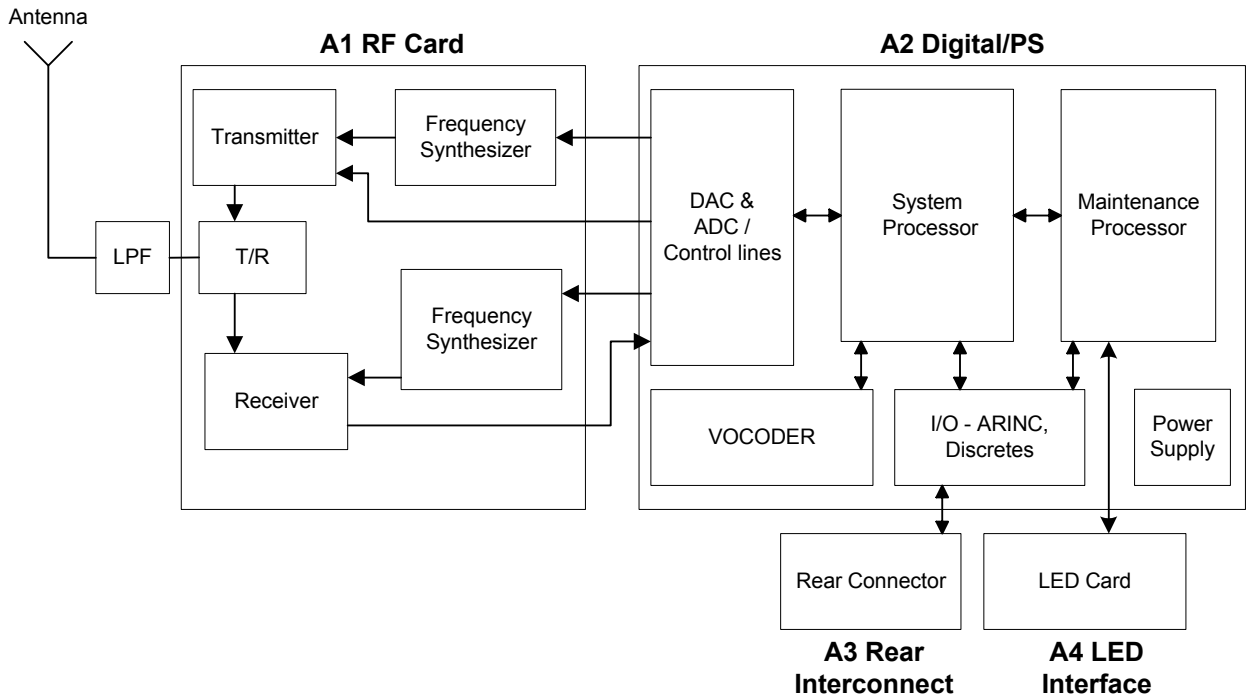

## 1.1.2 Interface Diagram

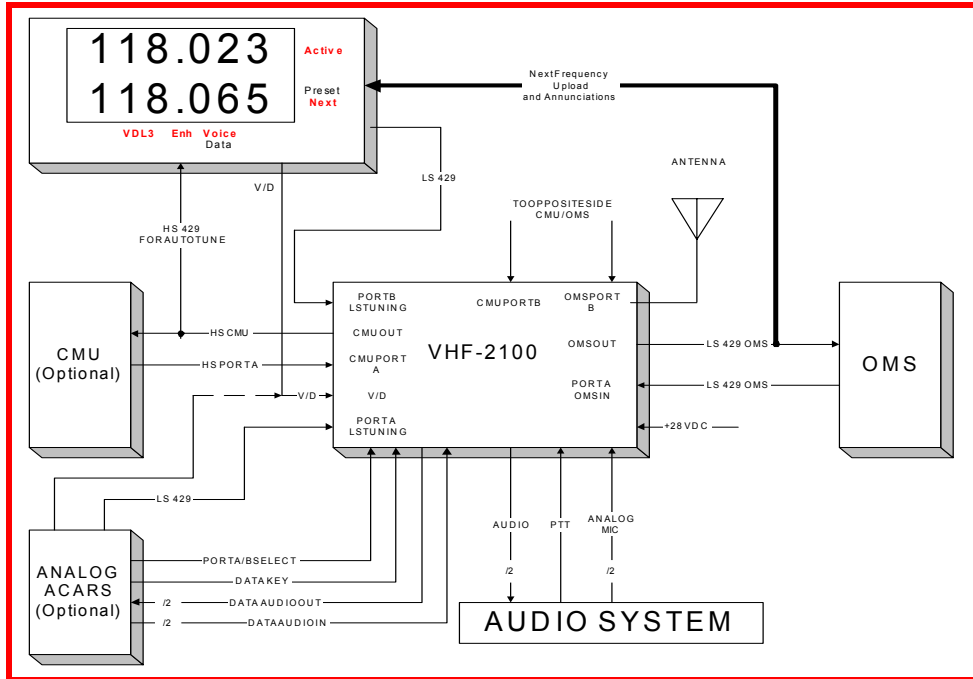

### **1.1.3 System Interconnect Diagram**

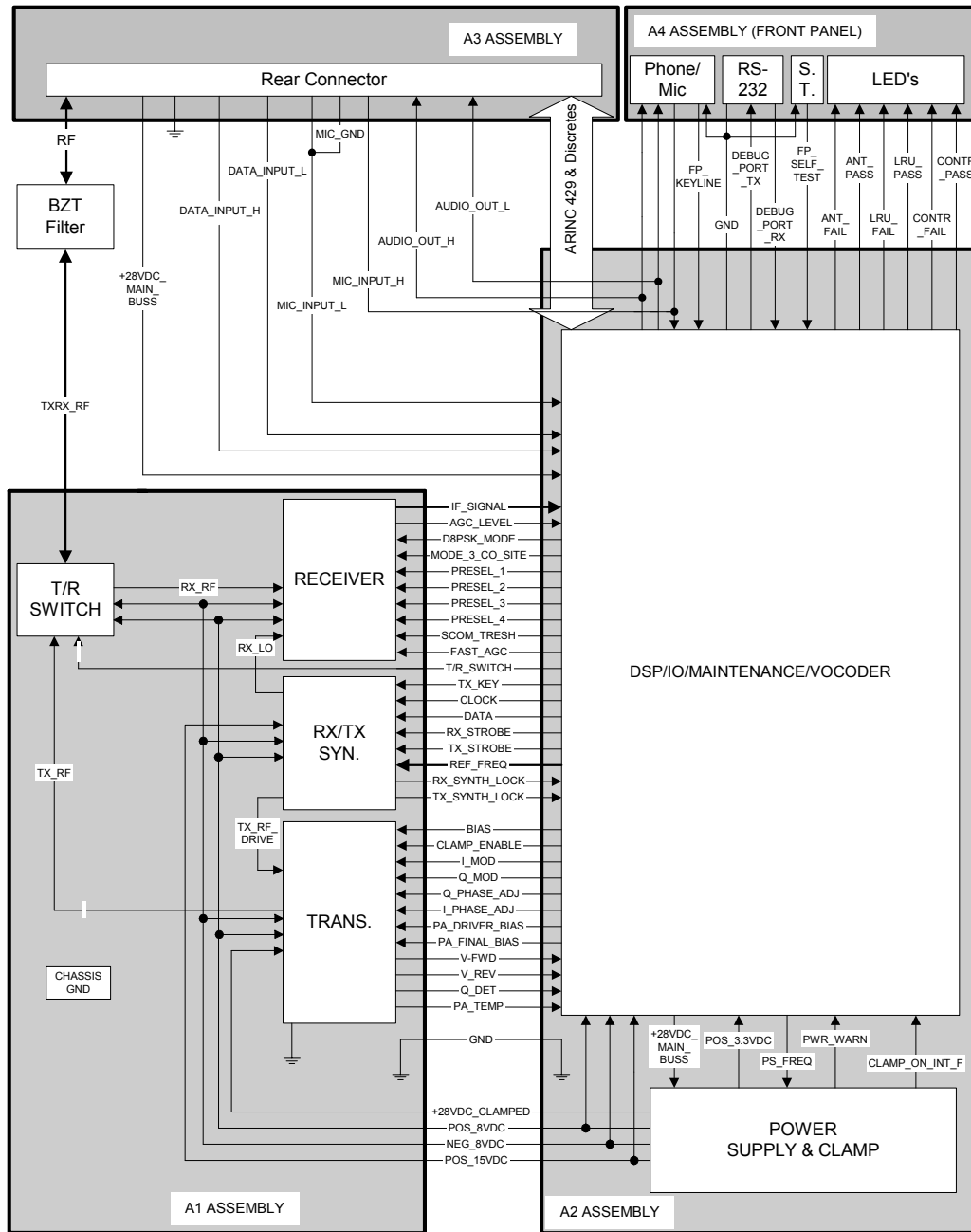

VHF-2100 ASSEMBLY INTERFACE DIAGRAM

KEY  
 COAX \_\_\_\_\_  
 RIBBON \_\_\_\_\_

### 1.1.4 Transmitter Block Diagram

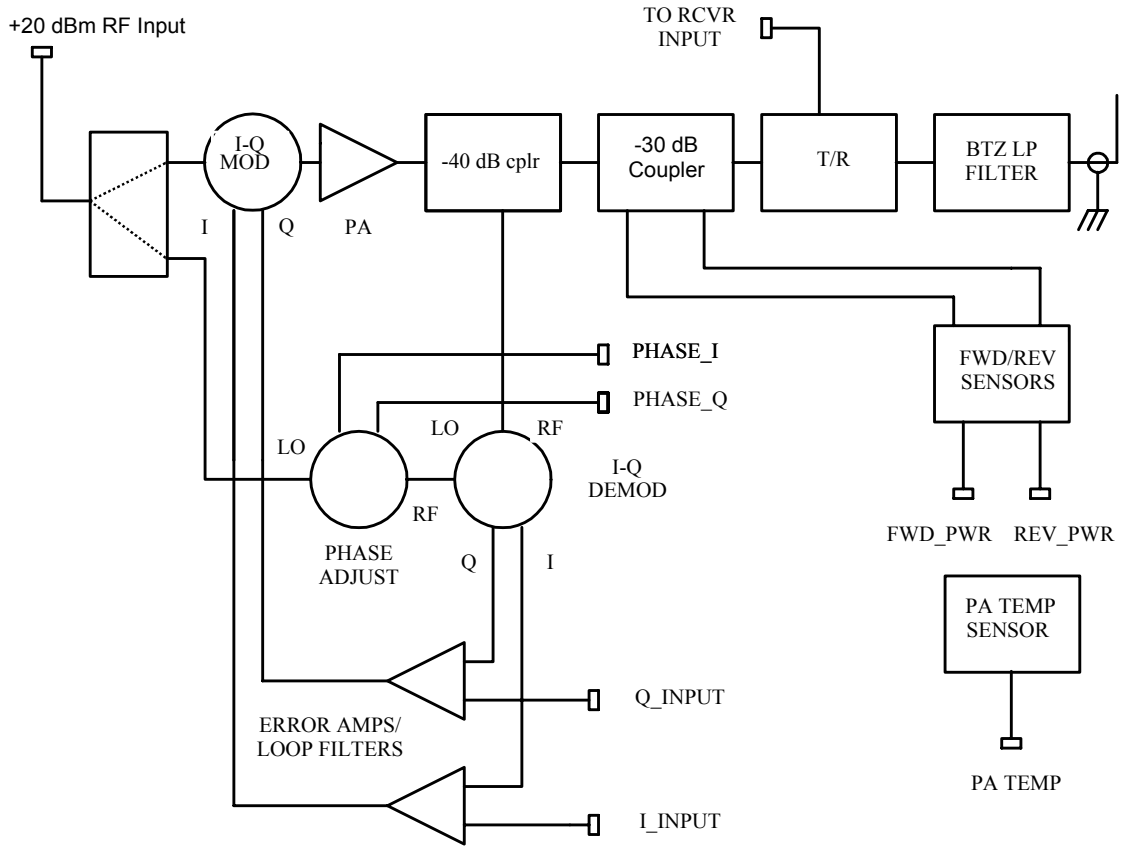

## 1.1.5 Receiver Block Diagram

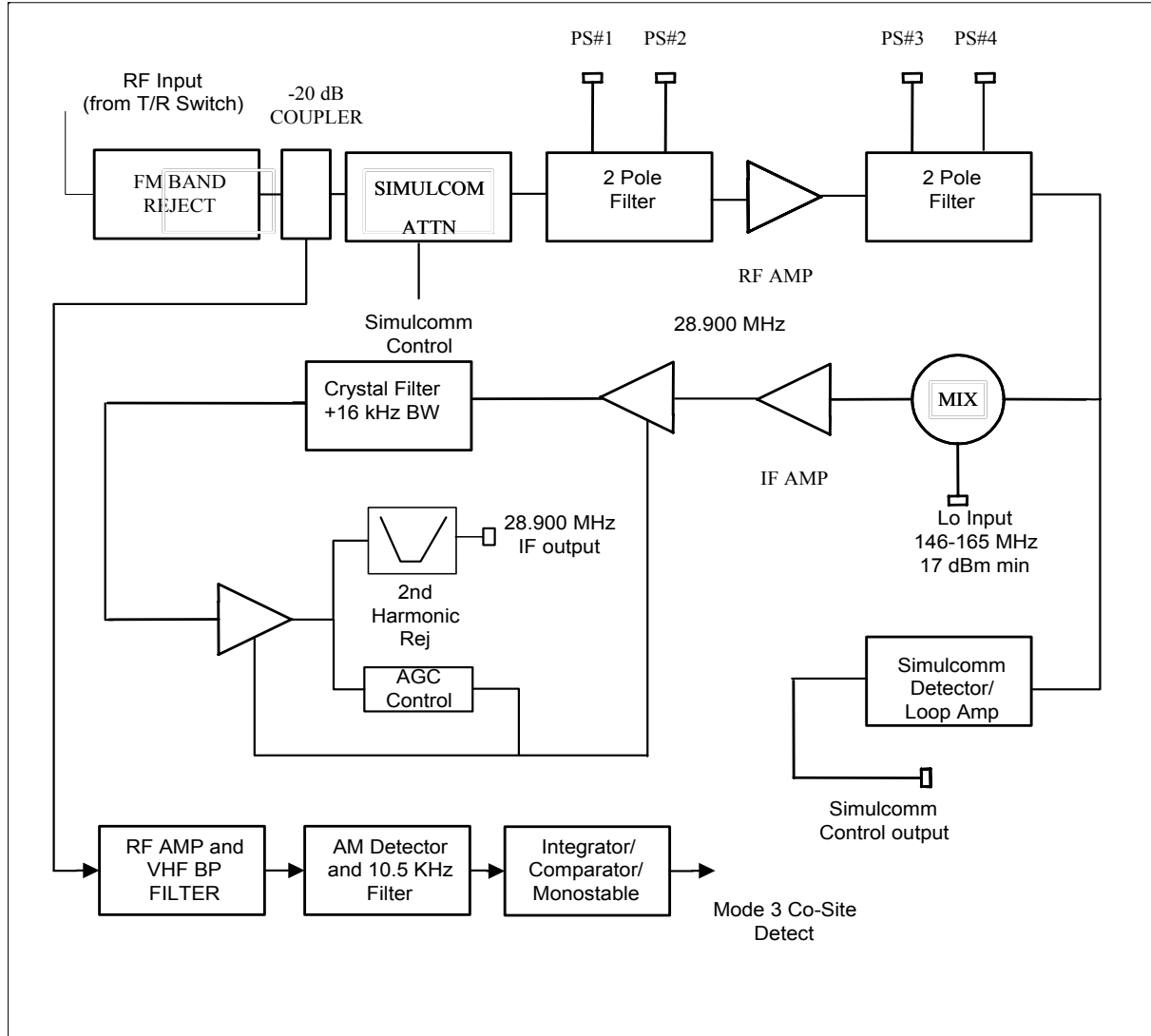

## 1.1.6 Transmit Synthesizer Block Diagram

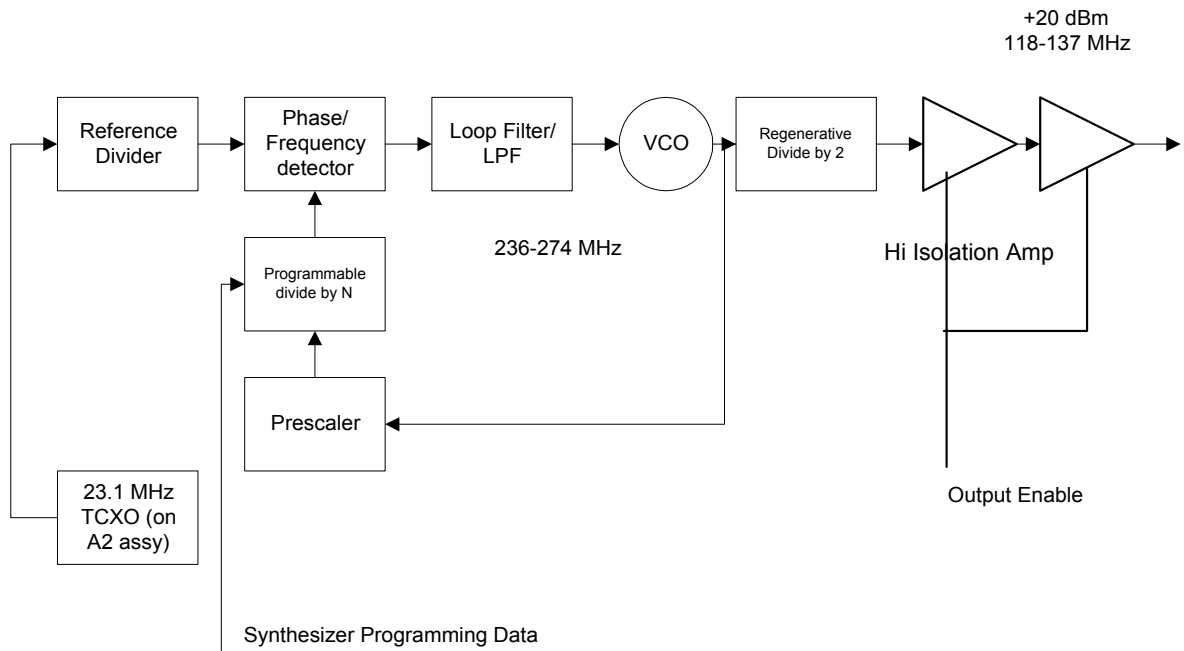

### 1.1.6.1 Detail of Regenerative Frequency Divider

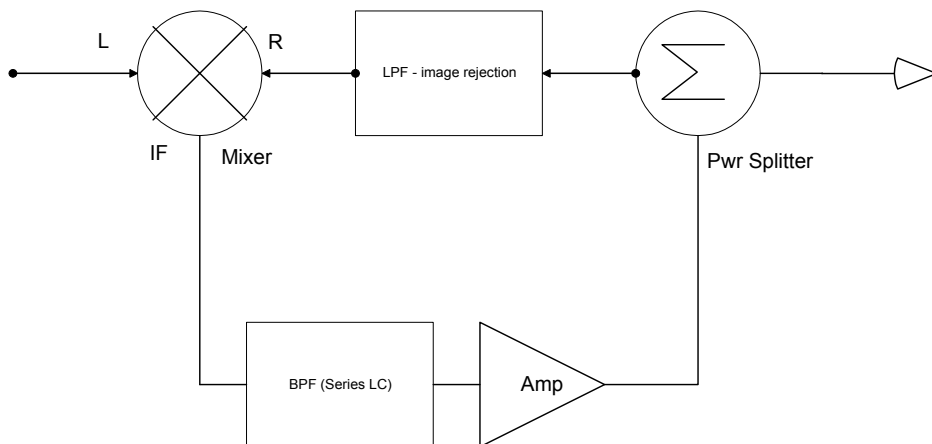

### 1.1.7 Receiver Synthesizer Block Diagram

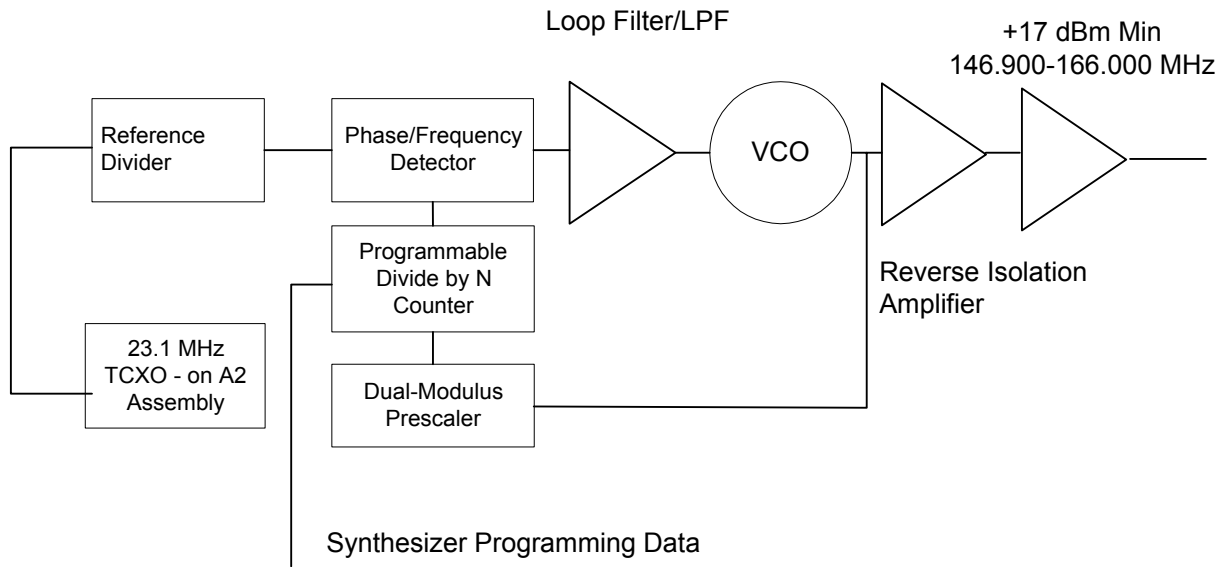

### 1.1.8 A2 DSP Circuit Card Block Diagram



