

Exhibit 9 – Required Measurements

9.1 Test Procedure and Compliance Matrix

This section details the test procedures and the test results that are concurrent and beyond the individual LRU test procedures/results. The Rockwell Collins LRU test procedures have been amended to include the FCC requirements described in Parts 2 and 87 of FCC Rules and Regulations.

The table below identifies the applicable sections of this document and its relationship between the Parts 2 and 87 requirements. The test results are appended to the individual test sections.

9.2 Test Requirements Matrix

FCC Part 2 Section	FCC Part 87 Section	Test Description Summary	Section
2.1046	87.131	RF Power Output	9.4
2.1047	87.141	Modulation Characteristics	9.5
2.1049	87.135	Occupied Bandwidth	9.6
2.1051	87.139	Spurious Emissions at Antenna Terminals	9.7
2.1053	87.139	Field Strength of Spurious Radiation	9.8
2.1055	87.133	Frequency Stability	9.9
2.1057	87.139	Frequency Spectrum	9.10
N/A	87.187 (q)	Priority and Preemption	9.11

9.3 Test Equipment

The test equipment listed in the following table was used to conduct the operational performance tests indicated herein and for collecting data except where shown differently in individual sections of this report. The actual test setups for each test are described in the individual sections.

Item Description	Item Number	Manufacturer and Model
IP-PC		286 or equivalent
Logging PC		286 or equivalent
MIDU	CPN 622-8587-008	
SRT-2000	-	Rockwell Collins
Spectrum Analyzer	HP 8544	
Spectrum Analyzer	HP8566B	Or equivalent
Power Sensor	HP 8481A	Or equivalent
GES Simulator	622-9760-00x	
Translator Panel		Rockwell Collins Custom
30 dB pad, 25 Watt pad		
20 dB pad		
10 MHz high stability reference (stability > 19.2 PPB)		
30 dB pad, 25 Watt pad		
Qual Test rack or equivalent		
HP Power Meter		
SRT-2000 Qual test station or equivalent		Rockwell Collins Custom
PHASE NOISE MEASUREMENT SYSTEM	HP3048A	
PHASE NOISE INTERFACE	HP11848A	
DYNAMIC SIGNAL ANALYZER	HP3561A	
HP3048A SOFTWARE	VERSION:REV:A.02.00	
SYSTEM COMPUTER	HP98580B	
RF SIGNAL GENERATOR	HP8663	
BROADBAND AMPLIFIER	HP8447A	
PLOTTER	HP 7475A	
T1206 SATCOM SYSTEM DFIU	JCAIR T1206	

9.4 RF Power Output

9.4.1 FCC Requirements

The discussion and test results shown in this section address and meet the requirements of the following FCC requirements:

Section 2.1046 (a)

For transmitters other than single sideband, independent sideband and controlled carrier radiotelephone, power output shall be measured at the RF output terminals when the transmitter is adjusted in accordance with the tune-up procedure to give the value of current and voltage on circuit elements specified in 2.1033 (c)(8). The electrical characteristics of the radio frequency load attached to the output terminals when this test is made shall be stated.

Section 2.1033 (c) (8)

The dc voltages applied to and dc currents into the several elements of the final radio frequency amplifying device for normal operation over the power range.

Section 87.131 Notes (1), (ii), (8)

(1) The power is measured at the transmitter output terminals and the type of power is determined according to the emission designator as follows:

(ii) Peak envelope power (pX) for all emission designators other than those referred to in paragraph (I) of this note.

(8) Power may not exceed 60 watts per carrier. The maximum EIRP may not exceed 2000 watts per carrier.

9.4.2 Test Results

The SAT-2000 System output power to the antenna is equal to the power output from the High Power Amplifier (HPA) in SRT-2000, less the losses between the HPA and the antenna. These losses include cable loss, LAN/Diplexer loss, and

other interconnection losses. They are installation dependent and are specified below:

Cable Loss = 3.70 dB maximum

LNA/Diplexer Loss = 0.8 dB maximum

Total HPA to Antenna Loss = 4.50 dB maximum

Typical values for these losses measured are:

Cable Loss = 1.1 to 3.7 dB

LNA/Diplexer Loss = 0.5 to 0.8 dB

Total HPA to Antenna Loss = 1.6 to 4.5 dB

The HPA rated output power is 25 watts maximum for multiple carriers.

The DC supply voltages and typical DC current values for the HPA are listed in the table below.

DC Supply Voltage	Maximum DC Supply Current	Typical Measured DC Supply Current
+25 VDC	4.80 Amps	4.65 Amps
+15 VDC	0.45 Amps	0.34 Amps
-15 VDC	0.15 Amps	0.08 Amps
+5 VDC	0.015 Amps	.007 Amps

9.5 Modulation Characteristics

The formatted data, described under Exhibit 2, is used to phase modulate a subcarrier signal. Binary phase shift keying (BPSK) modulation is used for all data rates less than 2400 BPS and quadrature phase shift keying (QPSK) is used for all data rates greater than 2400 BPS.

For BPSK modulation, the subcarrier signal phase value is varied by -90 or 90 degrees depending on the formatted data bit being a 0 or a 1, respectively. For QPSK modulation the 4 states of each 2 bits of the formatted data is used to vary the subcarrier signal phase value by 45, 135, -135, or -45 degrees, according to a specified state/phase mapping. The modulation characteristics supported by SRT-2000 are indicated in the table below.

The constellation and eye diagrams for each data rate supported is used to indicate the modulation scheme used for that data rate. The table below identifies the figure number for constellation/eye diagram for the applicable data rate. The timing diagram of the subcarrier signals is also shown for each data rate.

9.5.1 FCC Requirements

The discussion and test results shown in this section address and meet the requirements of the following FCC requirements:

Section 2.1047 (d)

A curve or equivalent data which shows that the equipment will meet the modulation requirements of the rules under which the equipment is to be licensed.

Section 87.141 (j)

Transmitters used at Aircraft earth stations must employ BPSK for transmission rates up to and including 2400 bits per second, and QPSK for higher rates.

9.5.2 Test Results

All modulation characteristics supported by SRT-2000 are indicated in the table below.

Refer to the corresponding photo of eye pattern and the constellation pattern of modulation characteristics shown.

SRT-2000 Modulation Types

Bit Rate	Symbol Rate	Modulation Type
600	600	A-BPSK
1200	1200	A-BPSK
10500	5250	A-QPSK
8400	4200	A-QPSK
21000	10500	A-QPSK

Figure	Description
9.5.2.1	Eye and Constellation Diagram for Data Rate of 600 bps – A-BPSK
9.5.2.2	Timing Diagram for Data Rate of 600 bps – A-BPSK
9.5.2.3	Eye and Constellation Diagram for Data Rate of 1200 bps – A-BPSK
9.5.2.4	Timing Diagram for Data Rate of 1200 bps – A-QPSK
9.5.2.5	Eye and Constellation Diagram for Data Rate of 10500 bps – A-QPSK
9.5.2.6	Timing Diagram for Data Rate of 10500 bps – A-QPSK
9.5.2.7	Eye and Constellation Diagram for Data Rate of 8400 bps – A-QPSK
9.5.2.8	Timing Diagram for Data Rate of 8400 bps – A-QPSK
9.5.2.9	Eye and Constellation Diagram for Data Rate of 21000 bps – A-QPSK
9.5.2.10	Timing Diagram for Data Rate of 21000 bps – A-QPSK

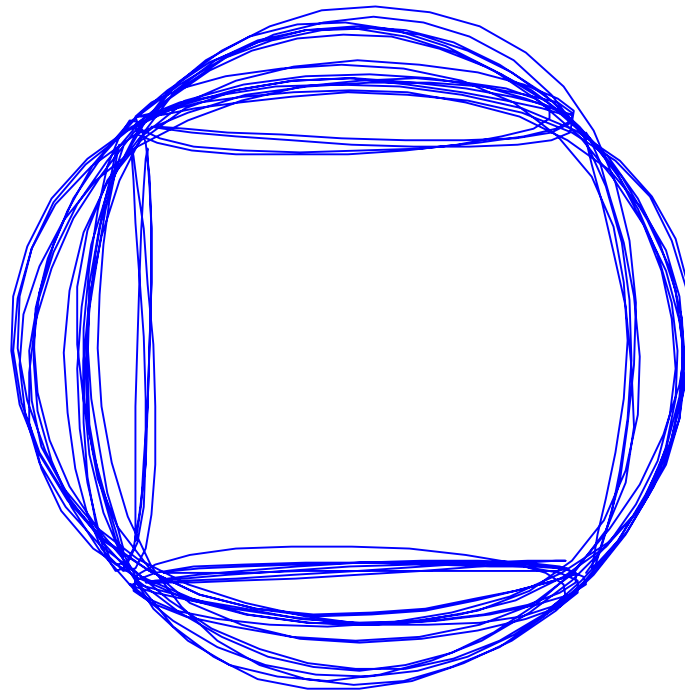
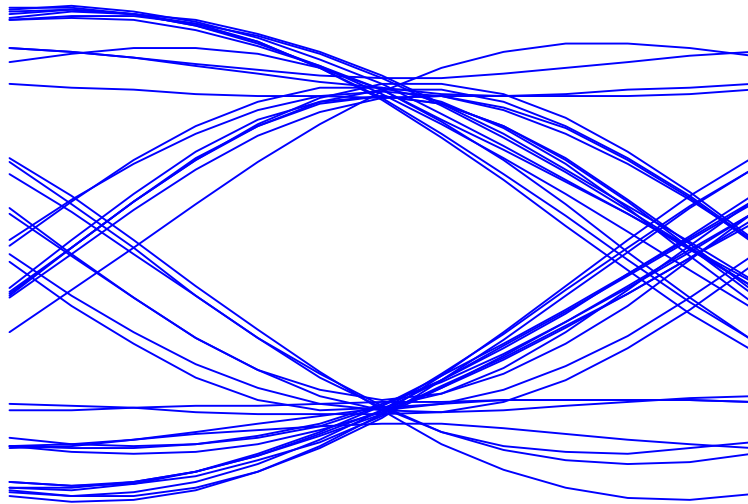
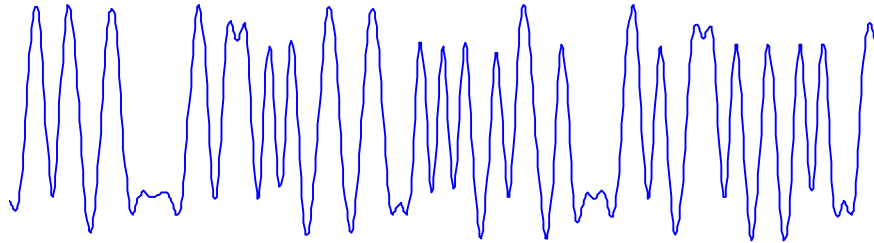

Figure 9.5.2.1 Eye and Constellation Diagram for Data Rate of 600 BPS - ABPSK



I Channel Above - Q Channel Below

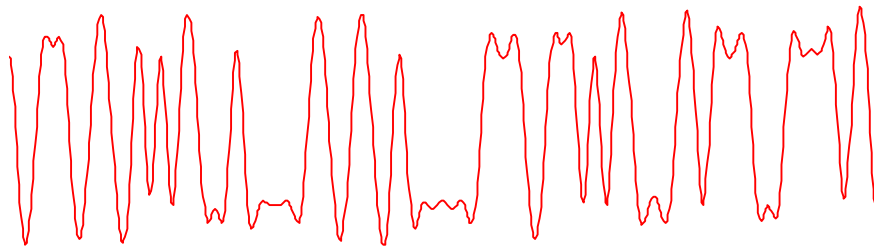

Figure 9.5.2.2. Timing Diagram for Data Rate of 600 BPS - ABPSK

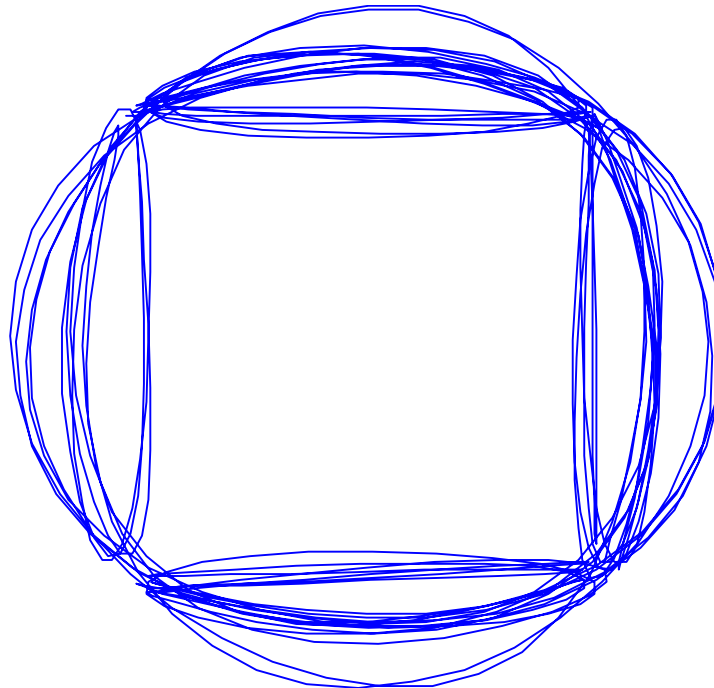
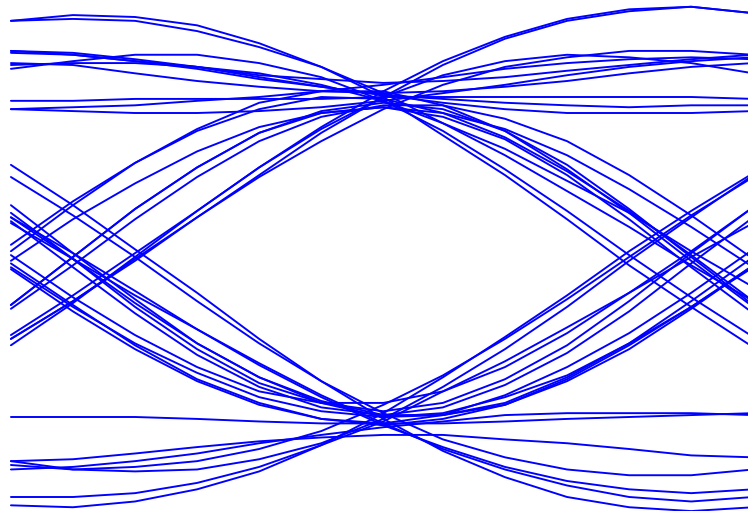
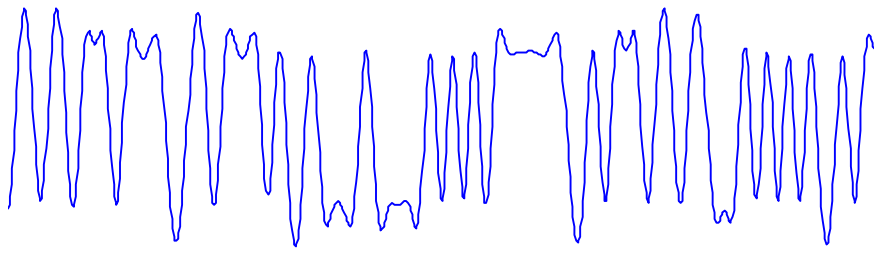

Figure 9.5.2.3 Eye and Constellation Diagram for Data Rate Of 1200 BPS - ABPSK



I Channel Above - Q Channel Below

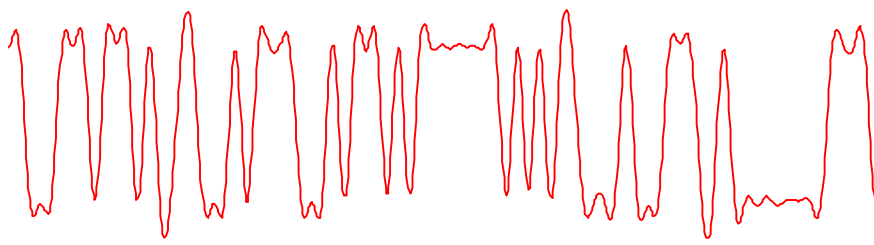

Figure 9.5.2.4 Timing Diagram for Data Rate 1200 BPS - ABPSK

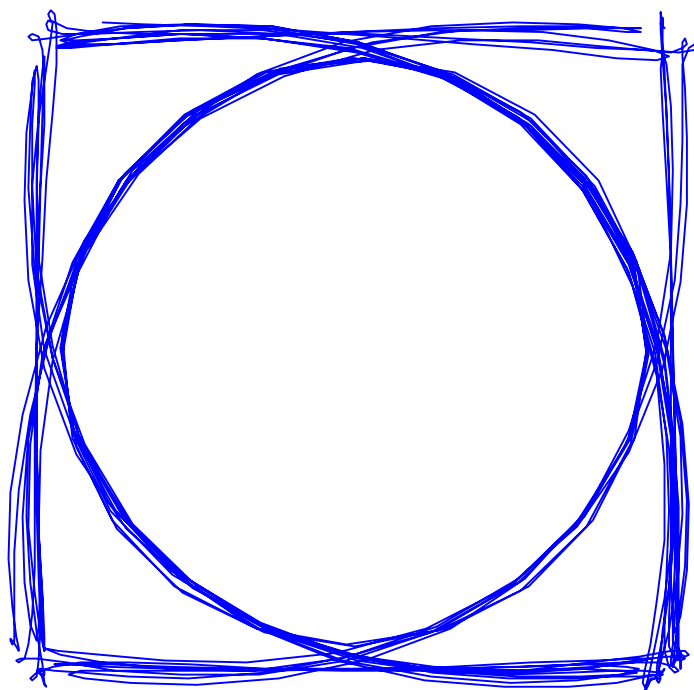
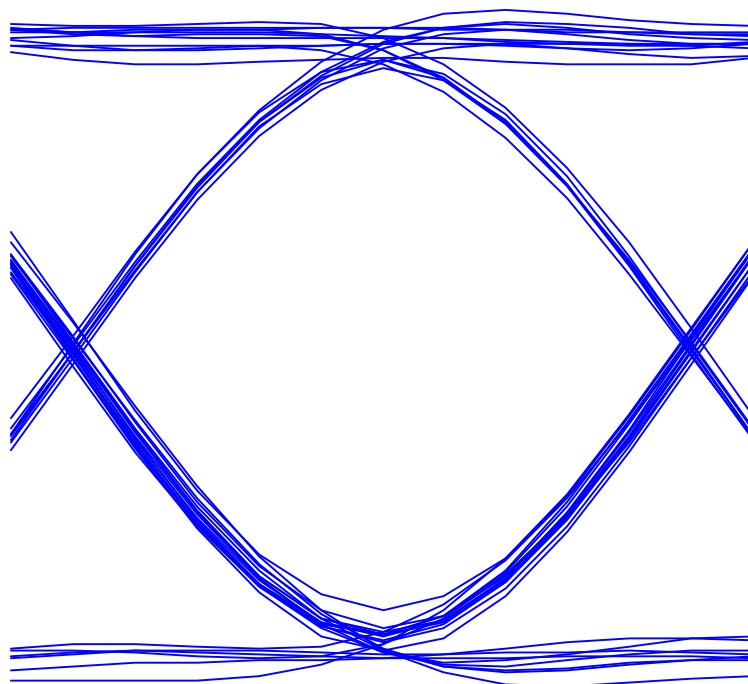
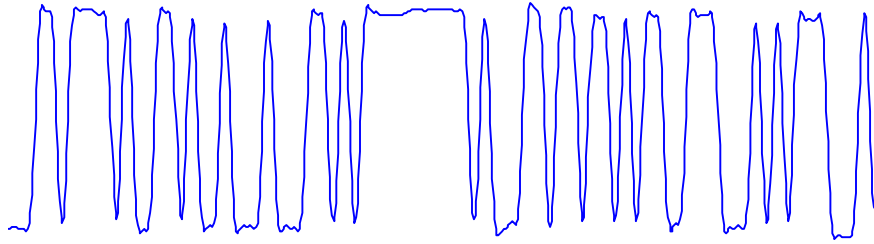

Figure 9.5.2.5 Eye and Constellation Diagram for Data Rate Of 10500 BPS - AQPSK



I Channel Above - Q Channel Below

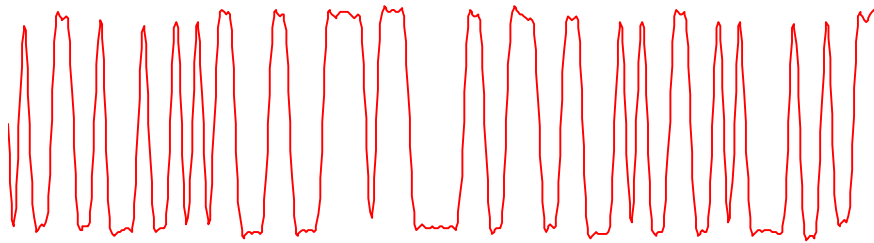

Figure 9.5.2.6 Timing Diagram for Data Rate Of 10500 BPS - AQPSK

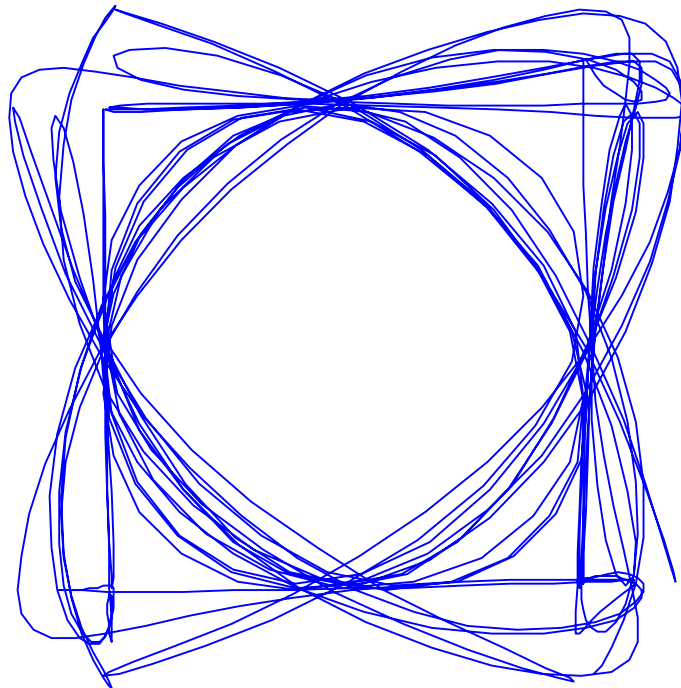
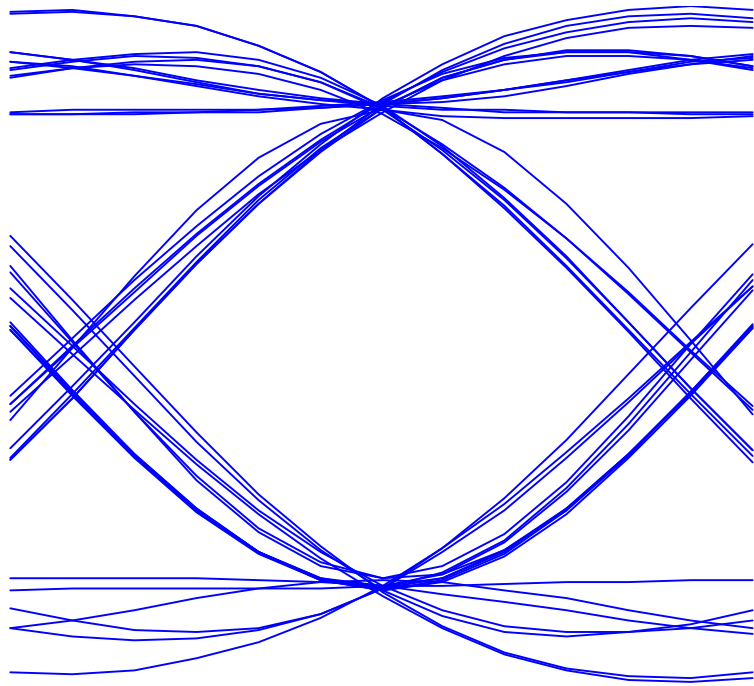
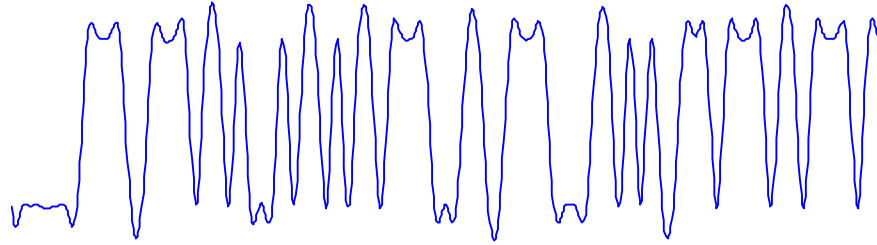

Figure 9.5.2.7 Eye and Constellation Diagram for Data Rate of 8400 BPS - AQPSK



I Channel Above - Q Channel Below

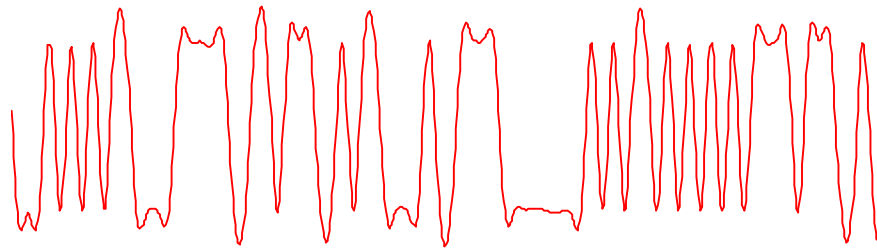

Figure 9.5.2.8 Timing Diagram for Data Rate of 8400 BPS - AQPSK

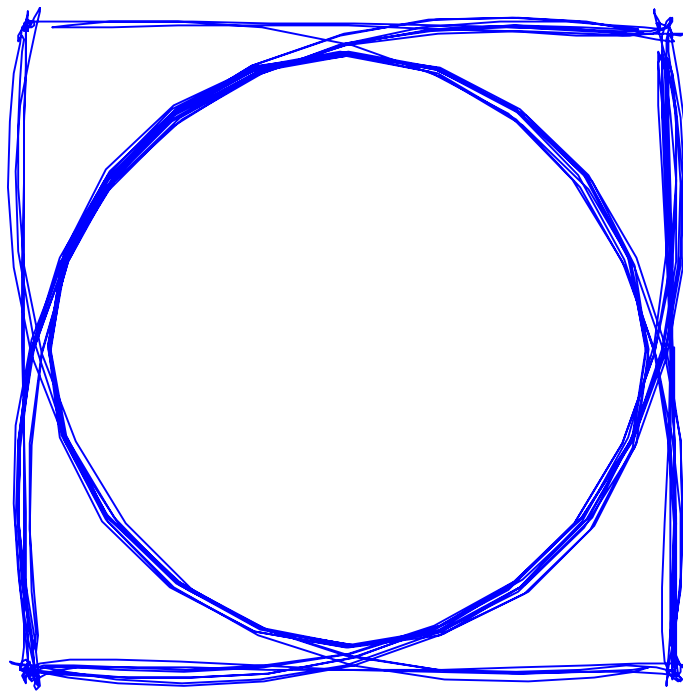
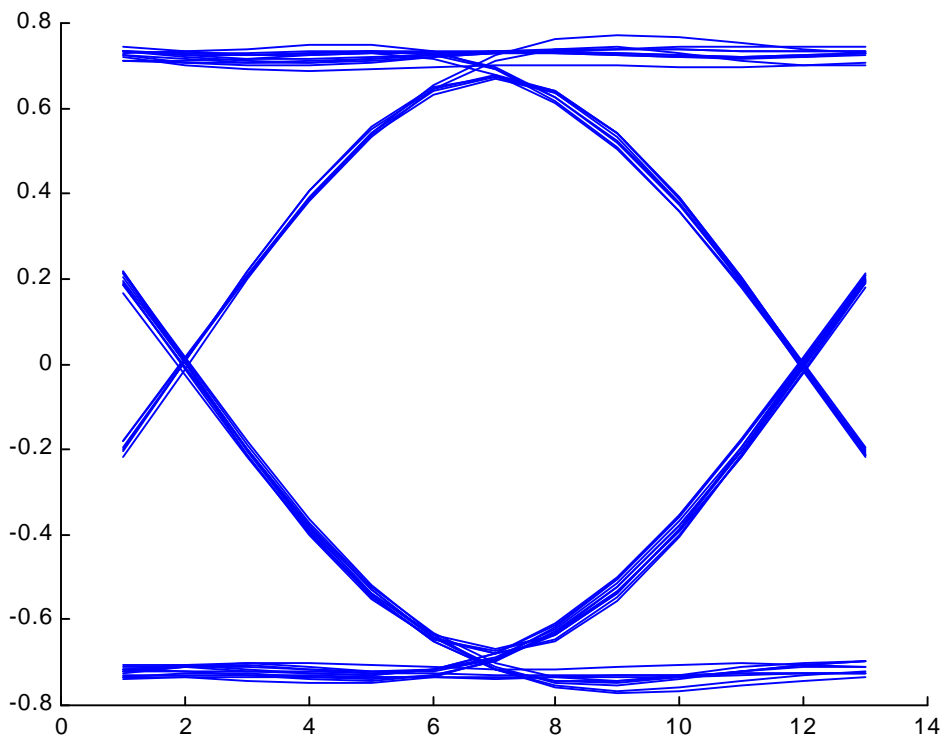

Figure 9.5.2.9 Eye and Constellation Diagram for Data Rate of 21000 BPS - AQPSK

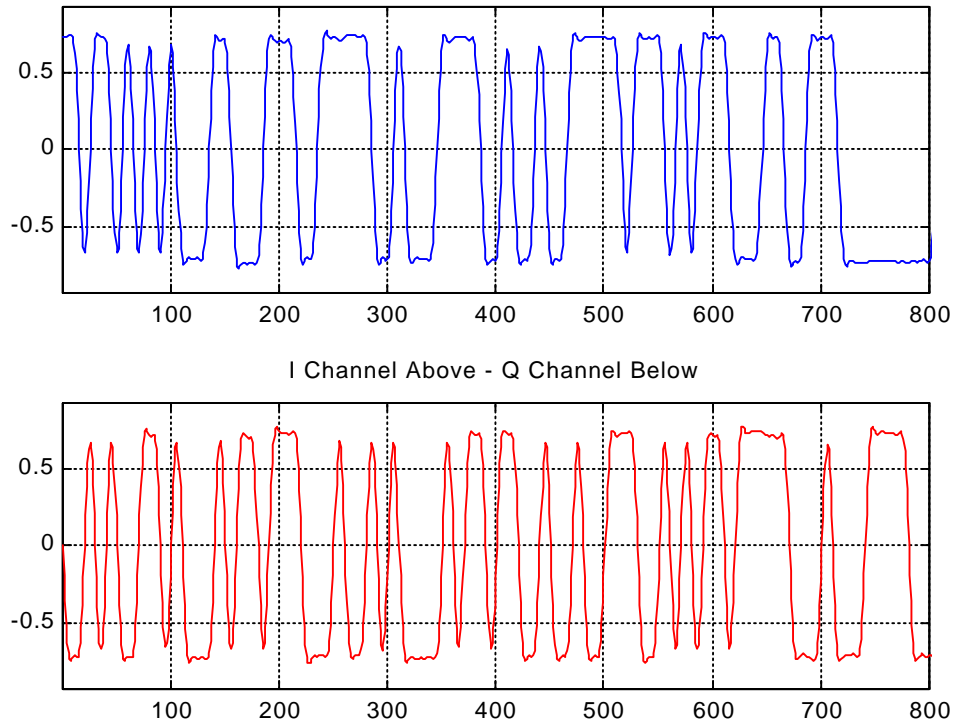

Figure 9.5.2.10 Timing Diagram for Data Rate of 21000 BPS - AQPSK

9.6 Occupied Bandwidth

9.6.1 FCC Requirements

The discussion and test results shown in this section address and meet the requirements of the following FCC requirements:

Section 2.1049

The occupied bandwidth, that is the frequency bandwidth such that, below its lower and above its upper frequency limits, the mean powers radiated are each equal to 0.5 percent of the total mean power radiated by a given emission shall be measured under the following conditions as applicable.

Section 2.1049 (h)

Transmitters employing digital modulation techniques – when modulated by an input signal such that its amplitude and symbol rate represent the maximum rated conditions under which the equipment will be operated. The signal shall be applied through any filter networks, pseudo-random generators or other devices required in normal service. Additionally, the occupied bandwidth shall be shown for operation with any devices used for modifying the spectrum when such devices are operational at the discretion of the user.

Section 87.135 (a), (b), (c)

(a) Occupied bandwidth is the width of a frequency band such that, below the lower and above the upper frequency limits, the mean powers emitted are equal to 0.5 percent of the total mean power of a given emission.

(b) The authorized bandwidth is the maximum occupied bandwidth authorized to be used by a station.

(c) The necessary bandwidth for a given class of emission is the width of the frequency band which is just sufficient to ensure the transmission of information at the rate and with the quality required under specified conditions.

Section 87.137 (a)

The assignable emissions, corresponding emission designators and authorized bandwidths for use by aircraft earth stations] are as follows:

Class of Emission	Emission Designator	Authorized Bandwidth (kilohertz)
G1D ¹	21K0G1D	25
G1E ¹	21K0G1E	25
G1W ¹	21K0G1W	25

¹Lower values of necessary and authorized bandwidth are permitted.

9.6.2 Test Procedures and Results

The system was configured per figure below and the transmitted output signal was measured on the spectrum analyzer. The spectrum measurement was made for all data rates supported by SRT-2000, and shown in the table below.

The spectrum analyzer output results are included as test results.

In all cases the measured bandwidth falls within the 25 kHz limit authorized bandwidth specified in Section 87.137.

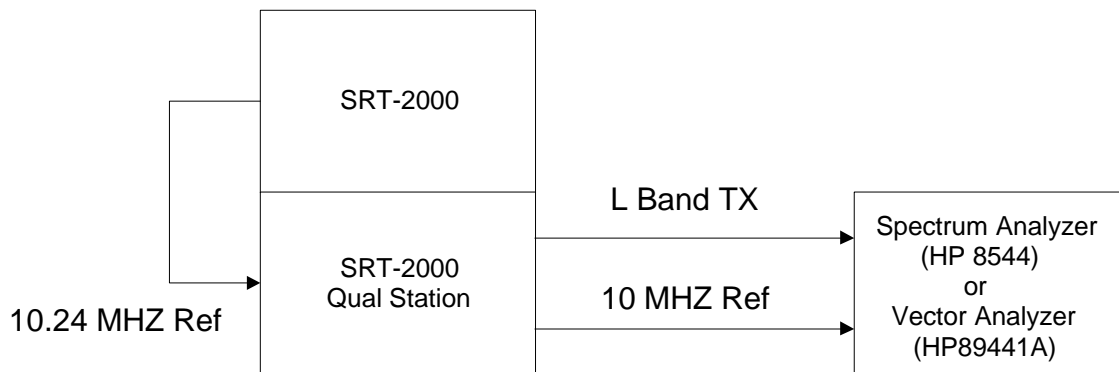

Figure 9.6.2 Occupied Bandwidth Test Setup

			Spectrum Analyzer Setting	
Data Rate (BPS)	Modulation Type	Symbol Rate (BPS)	Frequency Span	Resolution Band Width
600	A-BPSK	600	6.0 kHz	30 Hz
1200	A-BPSK	1200	12.0 kHz	100 Hz
10500	Q-BPSK	5250	52.5 kHz	150 Hz
8400	Q-BPSK	4200	42.0 kHz	150 Hz
21000	Q-BPSK	10500	105.0 kHz	300 Hz

The following tables are a summary of the measured bandwidths for the data rate and the transmit power indicated.

Table 9.6.2 Bandwidth Occupancy Test Result P = 25 Watts

Test Result Figure	Data Rate	BW at Transmit Frequency 1626.5 MHz	BW at Transmit Frequency 1643.5 MHz	BW at Transmit Frequency 1660.5 MHz
9.6.2.1	600 BPS	1.125 kHz	1.125 kHz	1.125 kHz
9.6.2.2	1200 BPS	1.750 kHz	1.625 kHz	1.875 kHz
9.6.2.3	8400 BPS	5.375 kHz	5.375 kHz	5.375 kHz
9.6.2.4	10500 BPS	6.625 kHz	6.625 kHz	6.625 kHz
9.6.2.5	21000 BPS	16.50 kHz	16.25 kHz	16.25 kHz

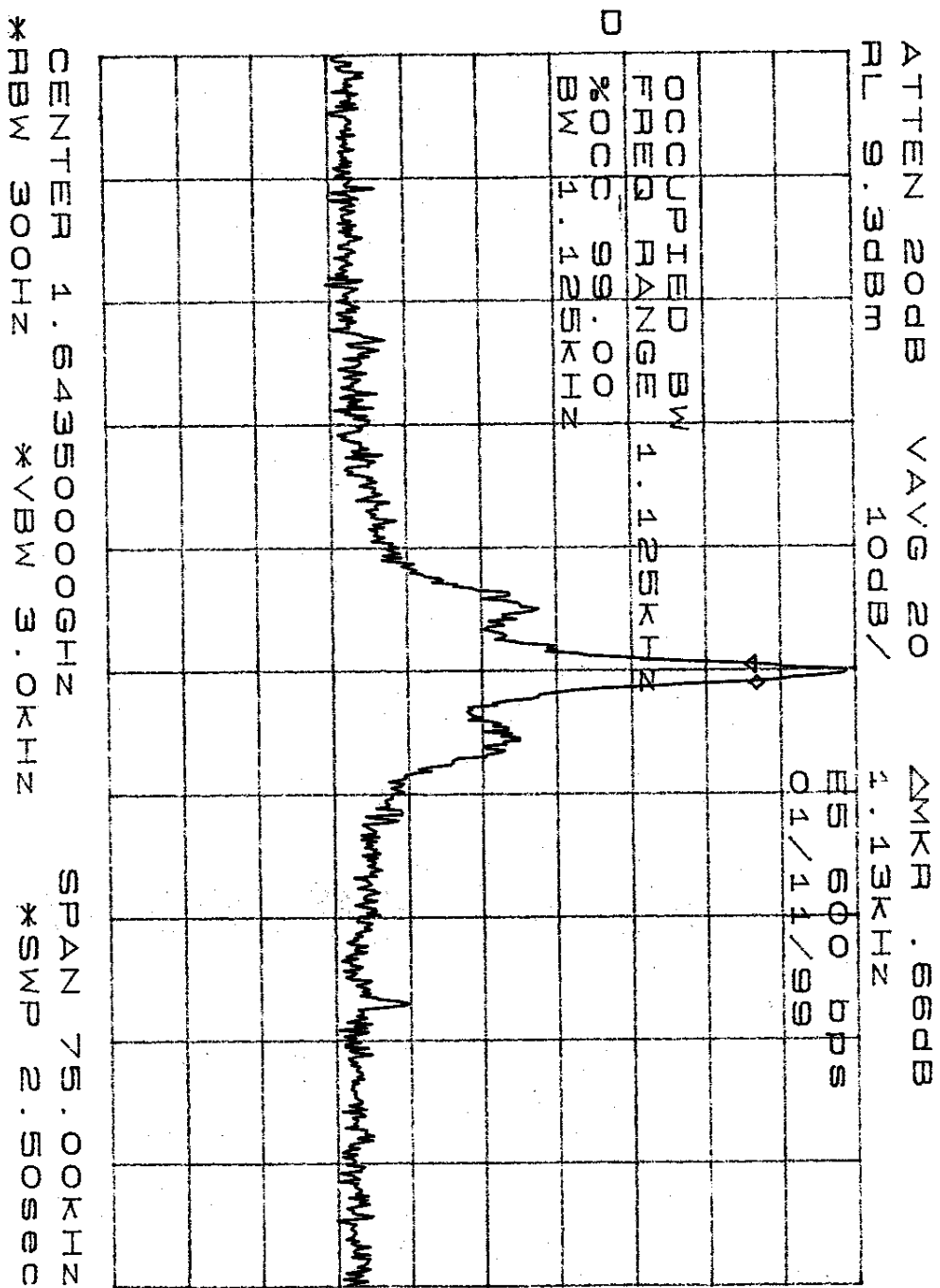

Figure 9.6.2.1 Bandwidth Occupancy Test – Power 25 Watts

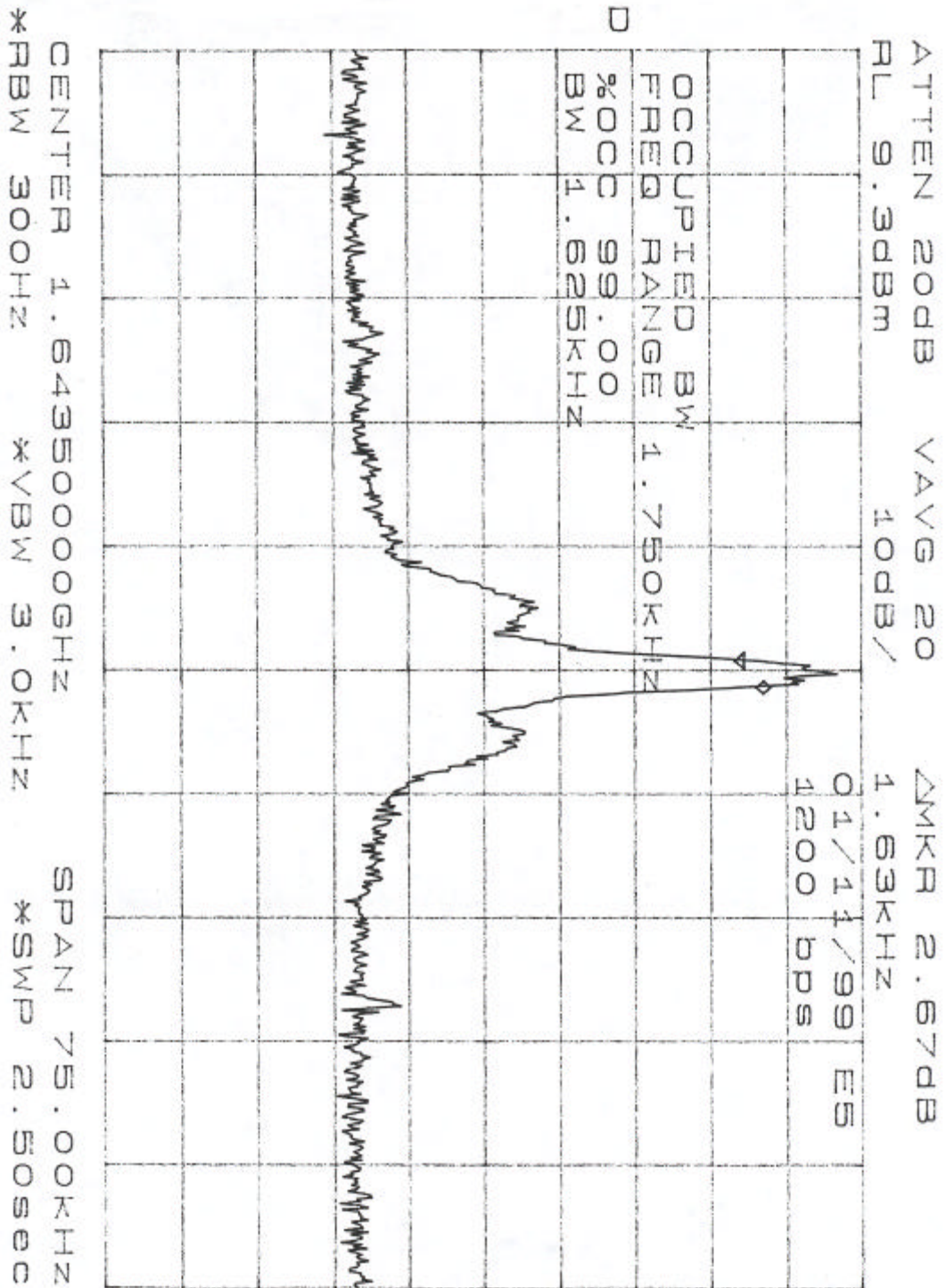

Figure 9.6.2.2 Bandwidth Occupancy Test – Power 25 Watts

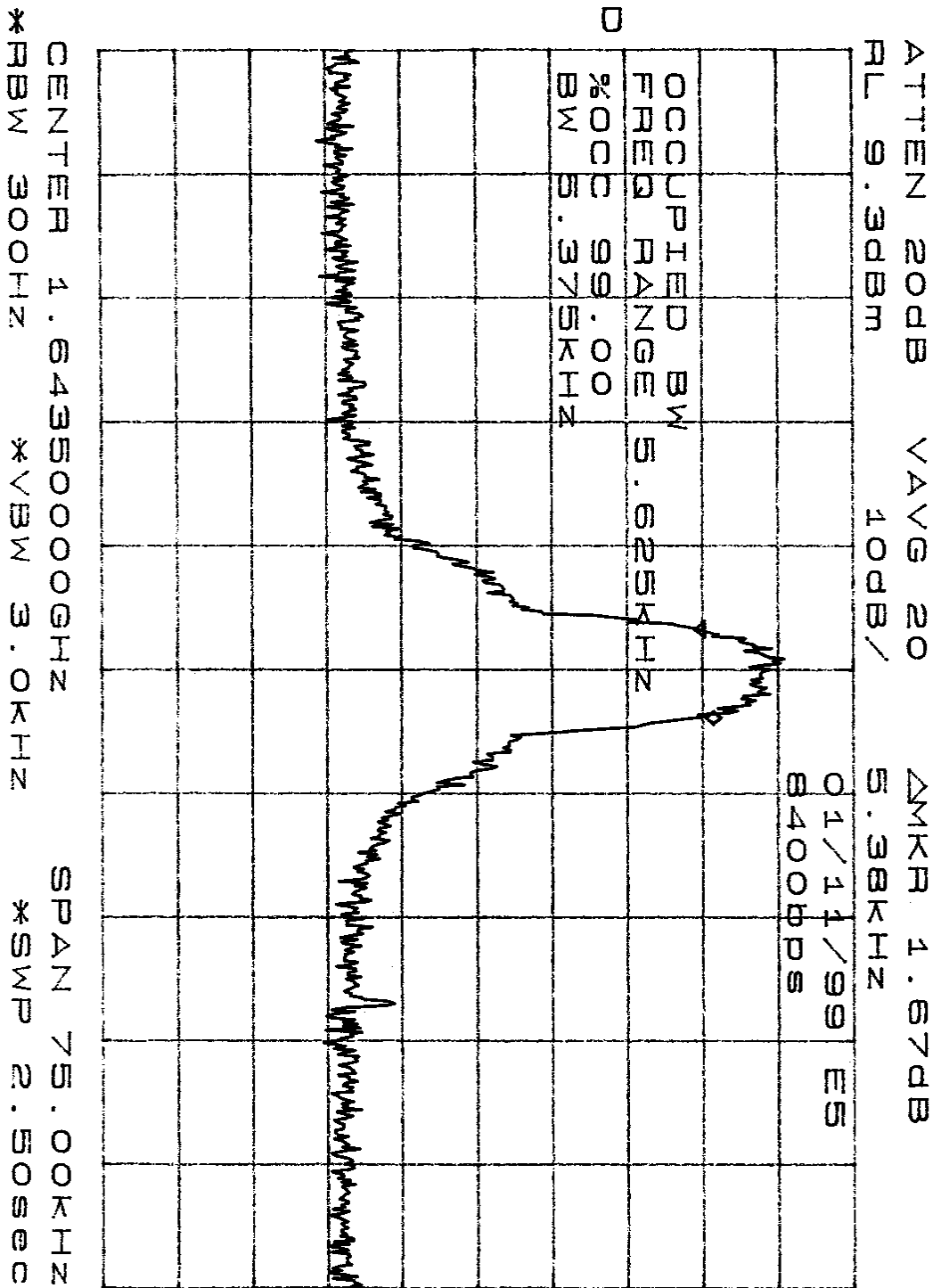

Figure 9.6.2.3 Bandwidth Occupancy Test – Power 25 Watts

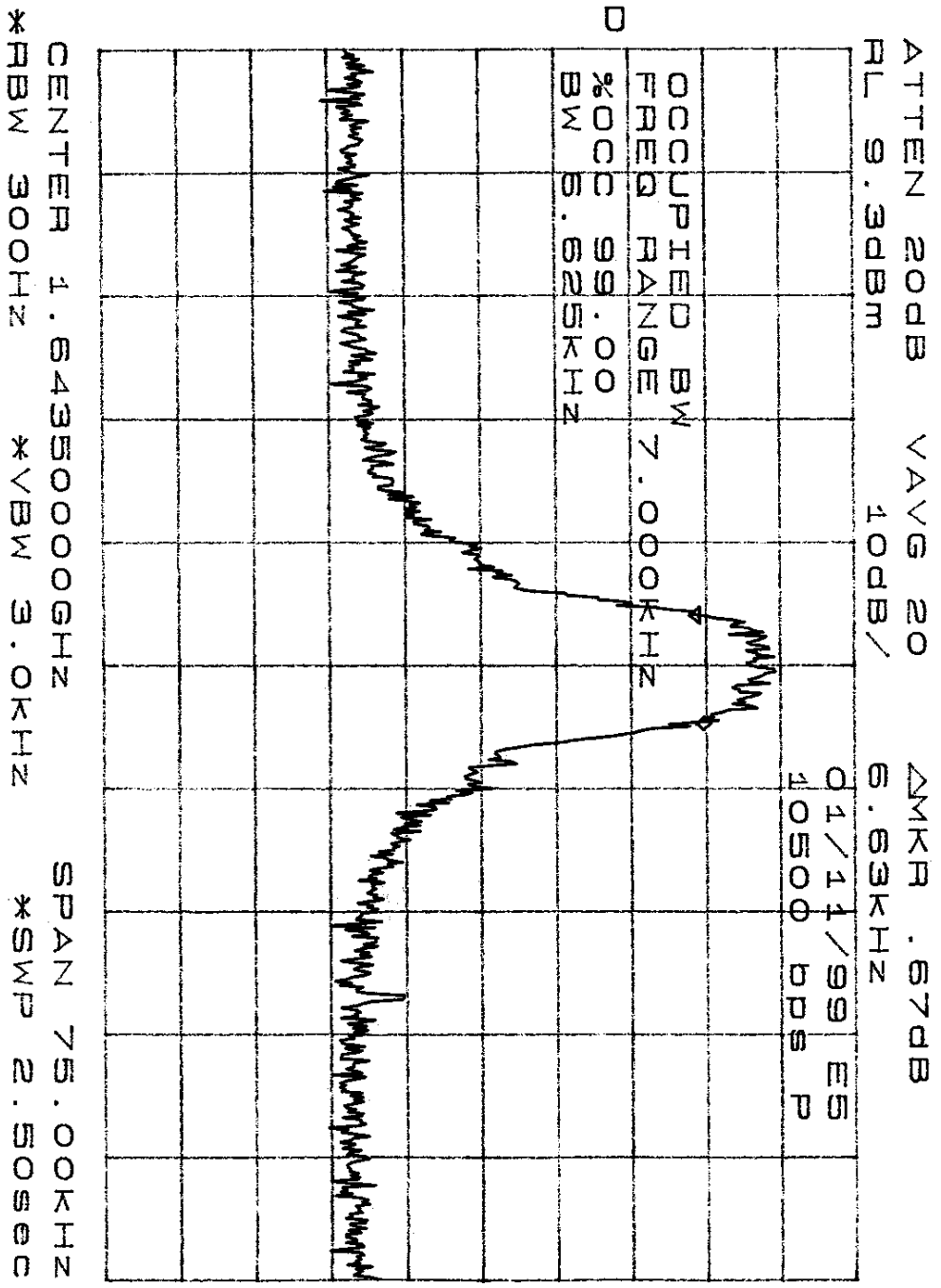

Figure 9.6.2.4 Bandwidth Occupancy Test – Power 25 Watts

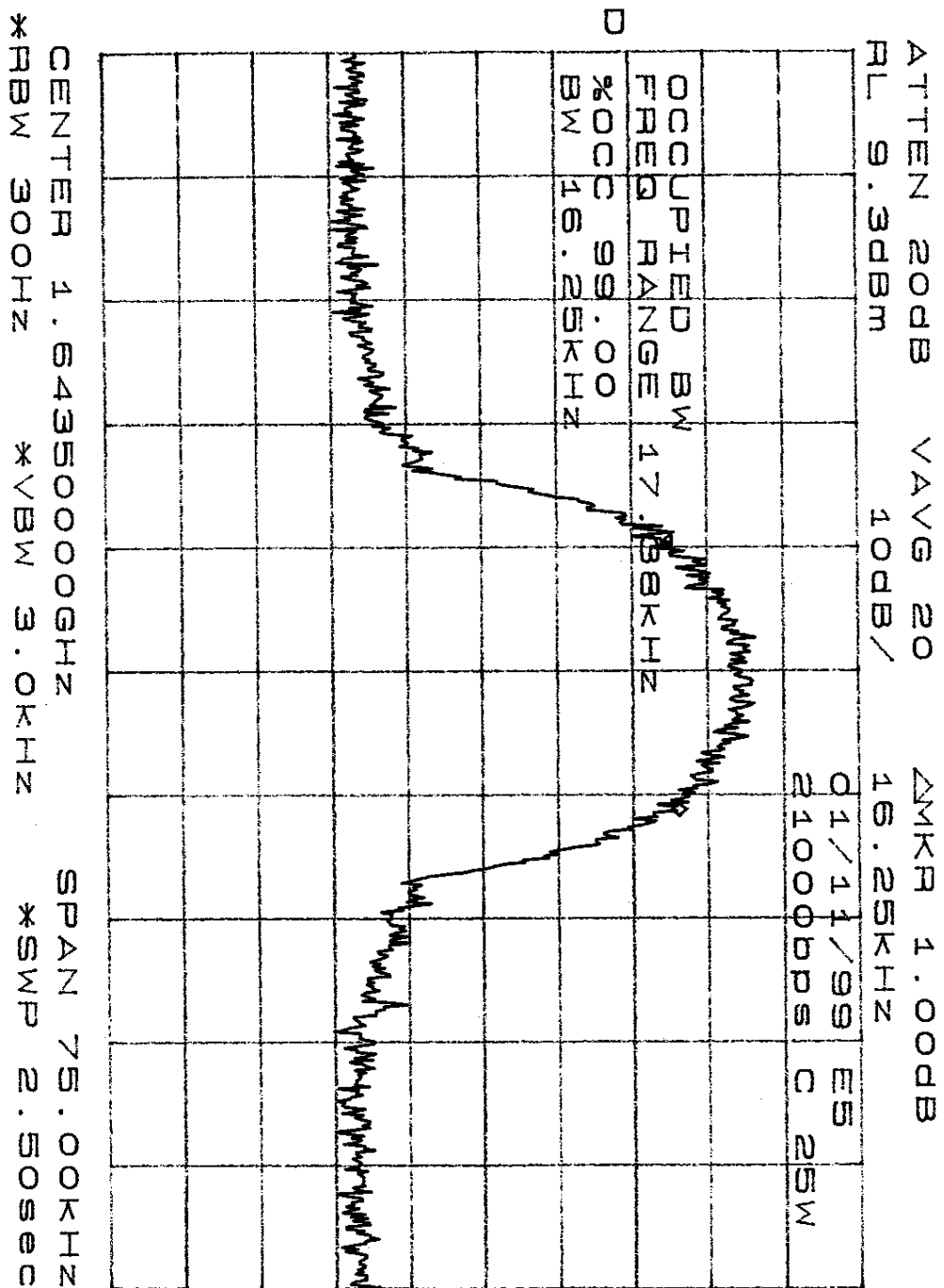

Figure 9.6.2.5 Bandwidth Occupancy Test – Power 25 Watts

9.7 Spurious Emissions at Antenna Terminals

9.7.1 FCC Requirements

The discussion and test results shown in this section address and meet the requirements of the following FCC requirements:

Section 2.1051

The radio frequency voltage or powers generated within the equipment and appearing on a spurious frequency shall be checked at the equipment output terminals when properly loaded with a suitable artificial antenna. Curves or equivalent data shall show the magnitude of each harmonic and other spurious emissions that can be detected when the equipment is operated under the conditions specified in Section 2.1049 as appropriate. The magnitude of spurious emissions attenuated more than 20 dB below the permissible values need not be specified.

Section 87.139 (i) (1), (2), (3), (4)

(i) In case of conflict with other provisions of Section 87.139, the provisions of this paragraph shall govern for aircraft earth stations. When using G1D, G1E, or G1W emissions in the 1646.5 – 1660.5 MHz frequency band, the emissions must be attenuated as shown below.

(1) At rated output power, while transmitting a modulated single carrier, the composite spurious and noise output shall be attenuated below the mean power of the transmitter, pY, by at least:

Frequency (MHz)	Attenuation (dB) ¹
.005 – 1559	83 or $(65 + 10\log_{10}(pY))$, whichever is greater
1559 – 18000	55 or $(37 + 10\log_{10}(pY))^2$, whichever is greater

¹ these values are expressed in dB below the carrier referenced to a 4 kHz bandwidth and relative to the maximum emission envelope level.

² excluding the frequency band of +/- 35 kHz or +/- 4.00 x Symbol Rate, about the carrier frequency, whichever is the greater exclusion.

(2) For transmitters rated at 60 watts or less:

When transmitting two unmodulated carriers, each 3 dB below the rated power, the mean power of any intermodulation products must be at least 24 dB below the mean power of either carrier.

(3) The transmitter emission limit is a function of the modulation type and the Symbol Rate (SR). Symbol Rate is expressed in symbols per second.

(4) While transmitting a single modulated signal at the rated output power of the transmitter, the emissions must be attenuated below the maximum emission level by at least:

Frequency Offset (normalized to SR)	Attenuation (dB)
+/- 0.75 x SR	0
+/- 1.40 x SR	20
+/- 2.80 x SR	40
+/- 4.00 x SR or +/- 35 kHz	F_m
Whichever is greater.	

where:

$F_m = 55$ or $(37 + 10\log_{10}(pY))$, whichever is greater

SR = Symbol Rate

SR = 1 x channel rate for BPSK

SR = 0.5 x channel rate for QPSK

The mask shall be defined by drawing straight lines through the above points.

9.7.2 Test Procedures

The SRT-2000 system spurious emissions measurements were made at the output of the LNA/Diplexer. Since the system's rated power is less than 40 watts (pY) or 16.02 dB, the spurious emissions must be attenuated by 83 dB from .005 MHz to 1559 MHz and by 55 dB from 1559 MHz to 18000 MHz.

The test conditions below were developed to verify compliance with these requirements.

Test Conditions for Spurious Emissions

Test Condition	Data Rate (BPS)	Carrier Frequency
1	600	1643.5 MHz
2	1200	1643.5 MHz
3	8400	1643.5 MHz
4	10500	1643.5 MHz
5	21000	1626.5 , 1643.5, 1660.5 MHz

The figure below shows the set up for this test.

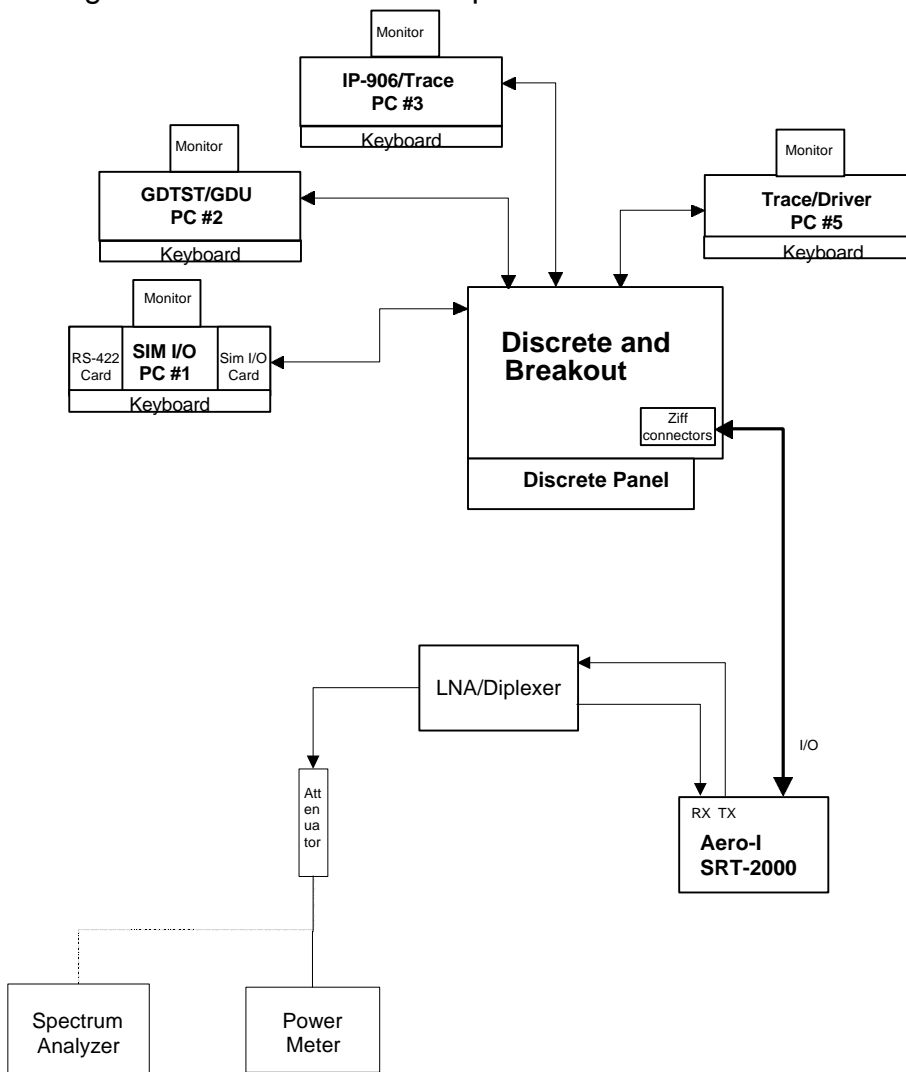

Figure 9.7.2 Spurious Emissions Setup

For each test condition in the above table, spectrum analyzer measurements were made according to the spectrum analyzer configuration per table below.

Figure No.	Frequency	Frequency Span	Resolution Bandwidth
9.7.2.1	Center	100 kHz	3 kHz
9.7.2.2	Center	1 MHz	3 kHz
9.7.2.3	Center	10 MHz	30 kHz
9.7.2.4	Center	100-MHz	100 kHz
9.7.2.5	-	1.5 - 2.56 GHz	10 kHz
9.7.2.6	-	2.0 – 22.6 GHz	100 kHz
9.7.2.7	-	1.0 – 1.56 GHz	10 kHz
9.7.2.8	-	0 – 1.0 GHz	10 kHz

The spectrum analyzer measures signal power in a particular “resolution bandwidth” as it sweeps across the selected frequency band and plots the data. If a wider bandwidth is used, more power is in that band and the point plotted is higher in amplitude. Section 87.139 (i) (1) footnote 1 states that “these values are expressed in dB below the carrier referenced to a 4kHz bandwidth and relative to the maximum emission envelope level.” Since some scans in the table above are taken with a 3 kHz resolution bandwidth, they contain 75% of the power that a 4kHz bandwidth measurement would have. Therefore, the correction factor in dB is $10\log_{10}(4/3) = 1.25$ dB.

No spurious or harmonic emissions were found to be out of the specifications. See attached representative sample plots.

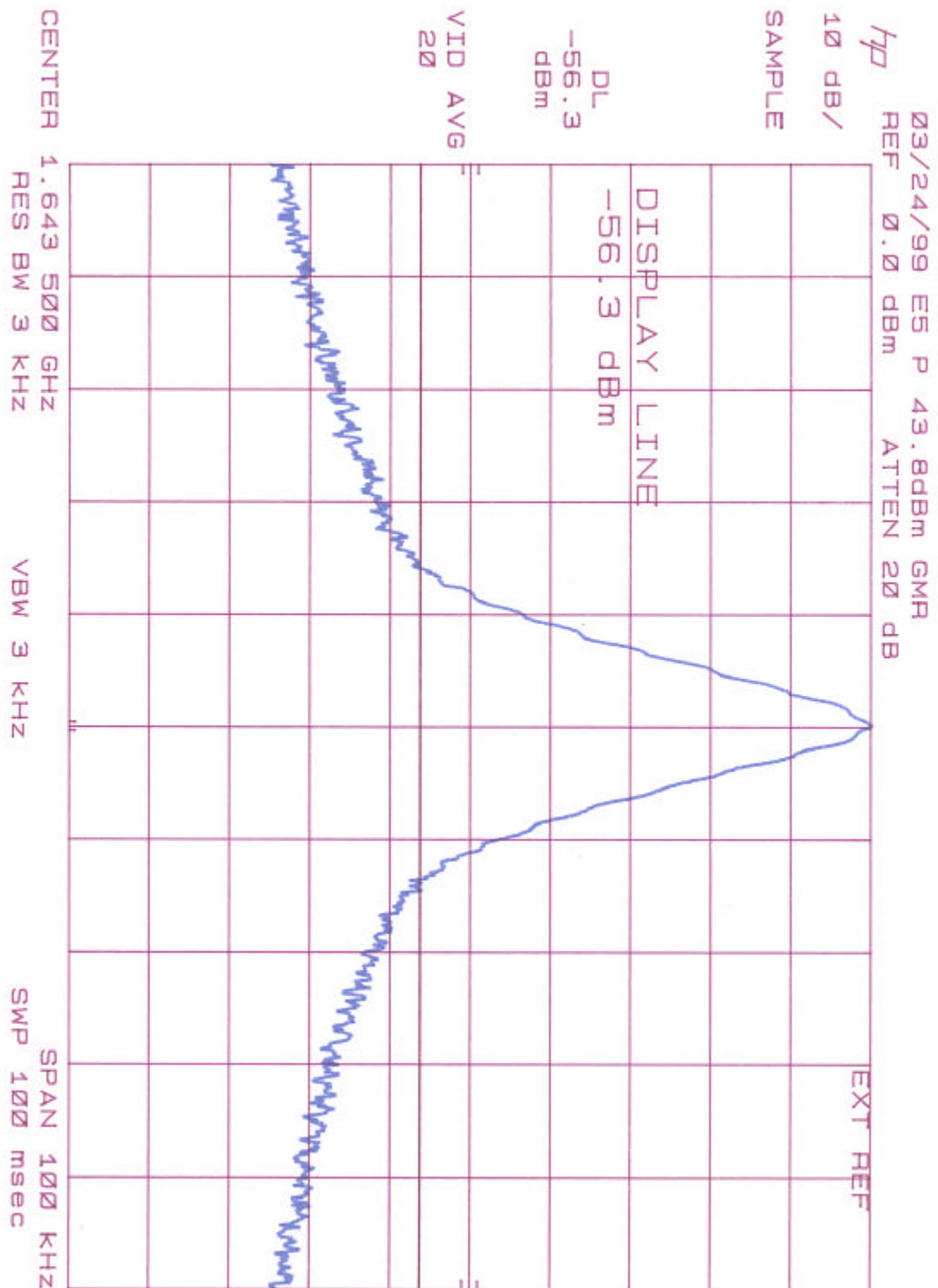

Figure 9.7.2.1 Spurious Emissions – Frequency Span 100 kHz

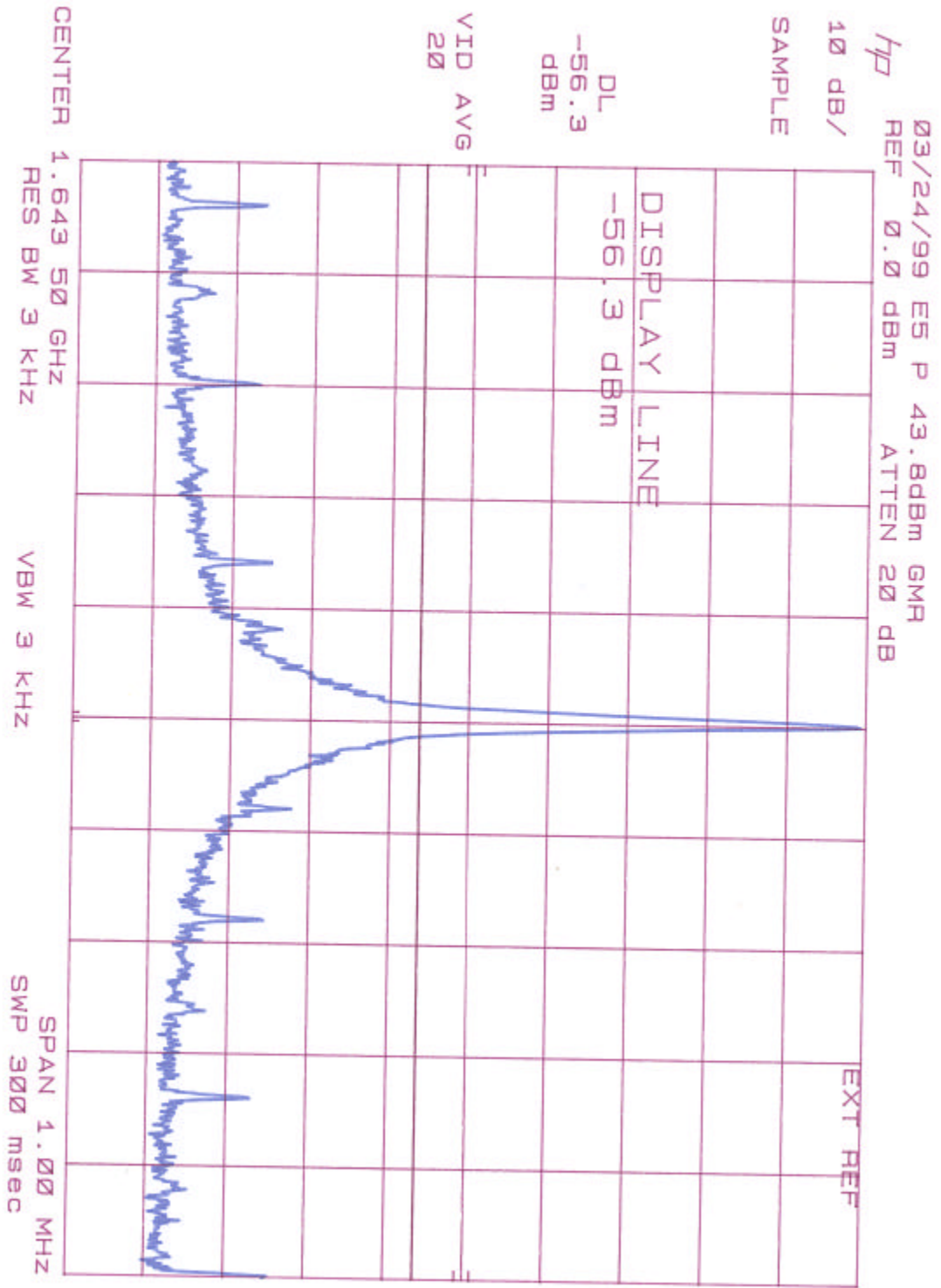

Figure 9.7.2.2 Spurious Emissions – Frequency Span 1 MHz

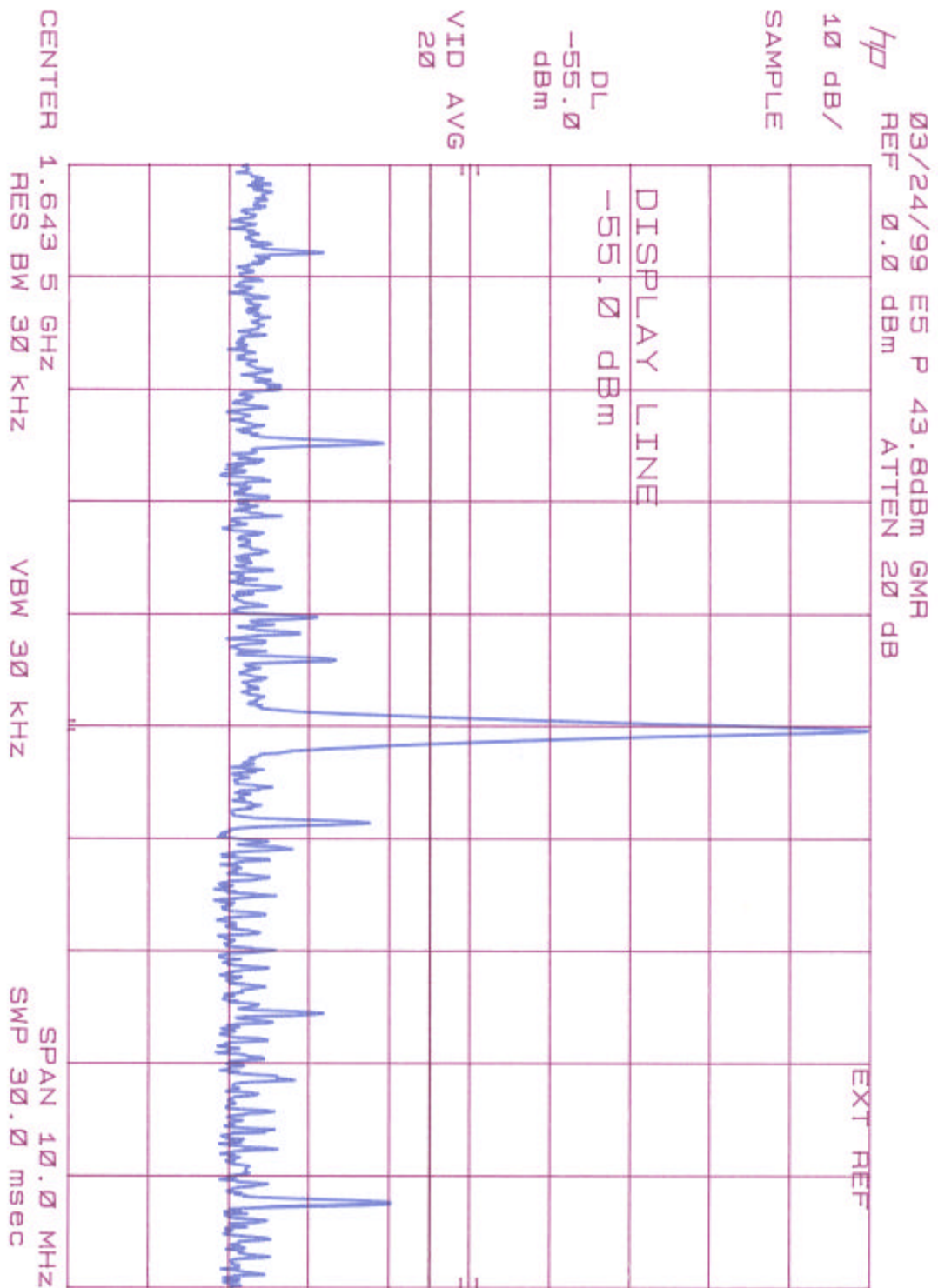

Figure 9.7.2.3 Spurious Emissions – Frequency Span 10 MHz

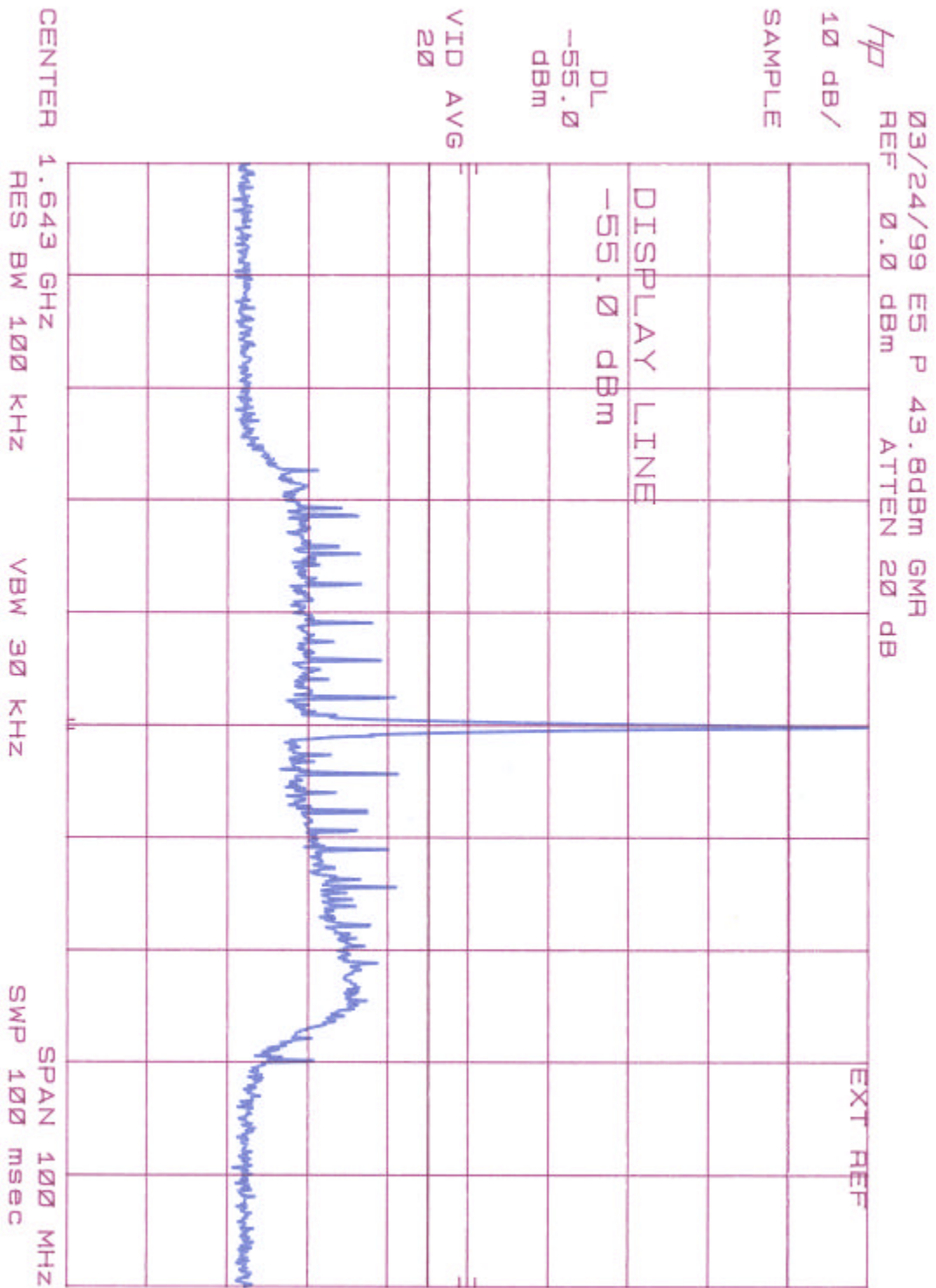

Figure 9.7.2.4 Spurious Emissions – Frequency Span 100 MHz

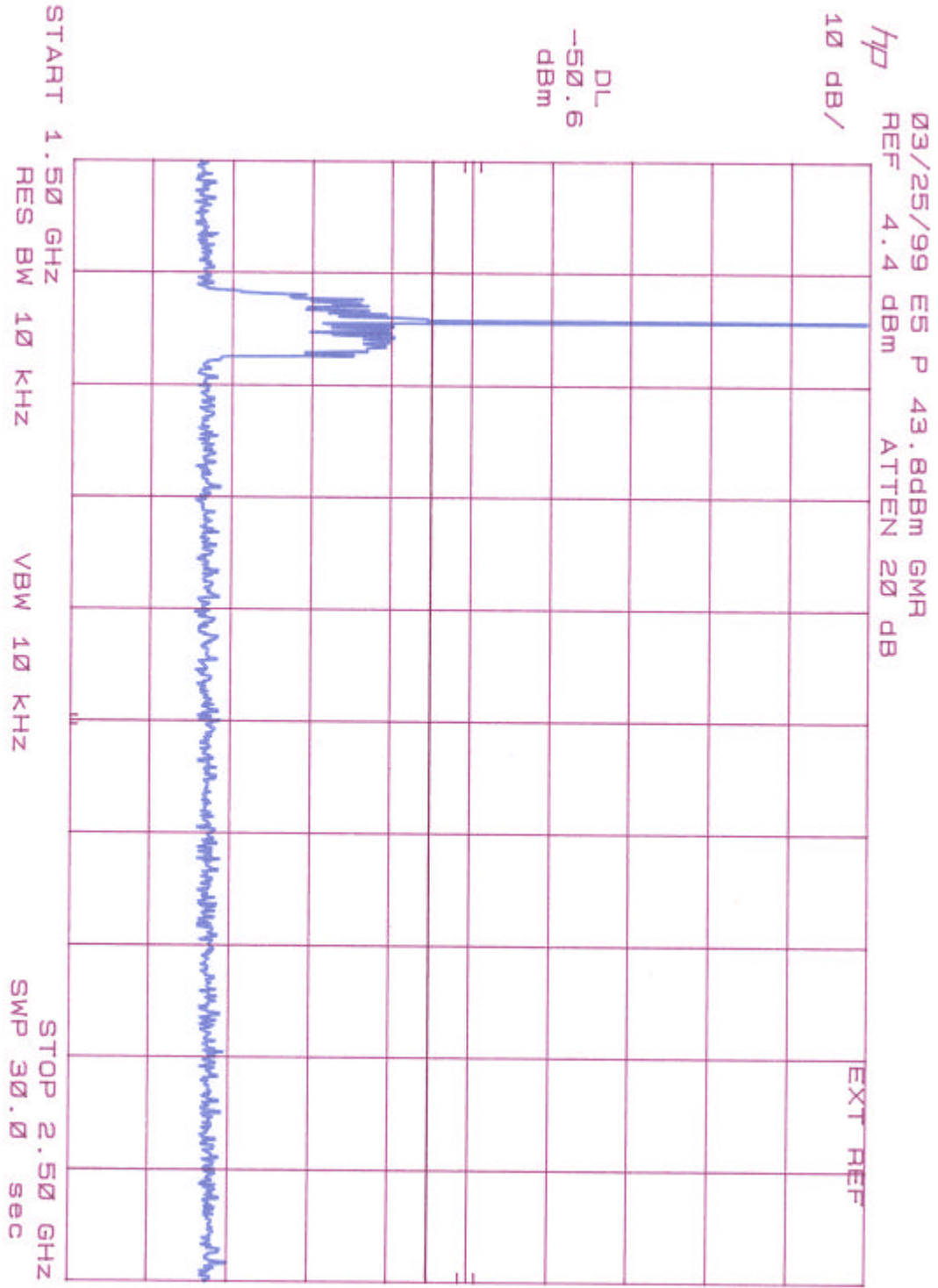

Figure 9.7.2.5 Spurious Emissions – Frequency Span 1.5 – 2.56 GHz

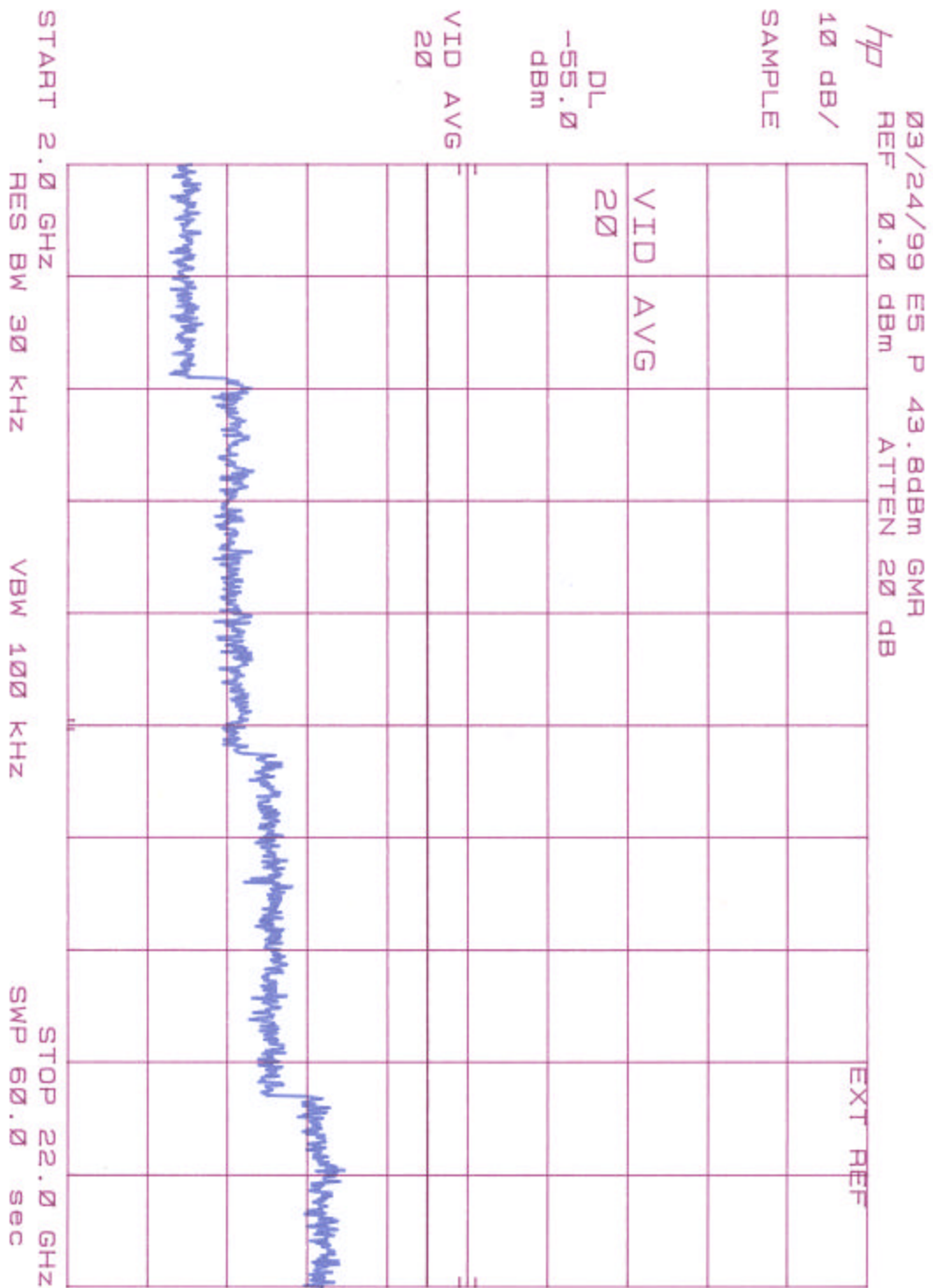

Figure 9.7.2.6 Spurious Emissions – Frequency Span 2.0 – 22.6 GHz

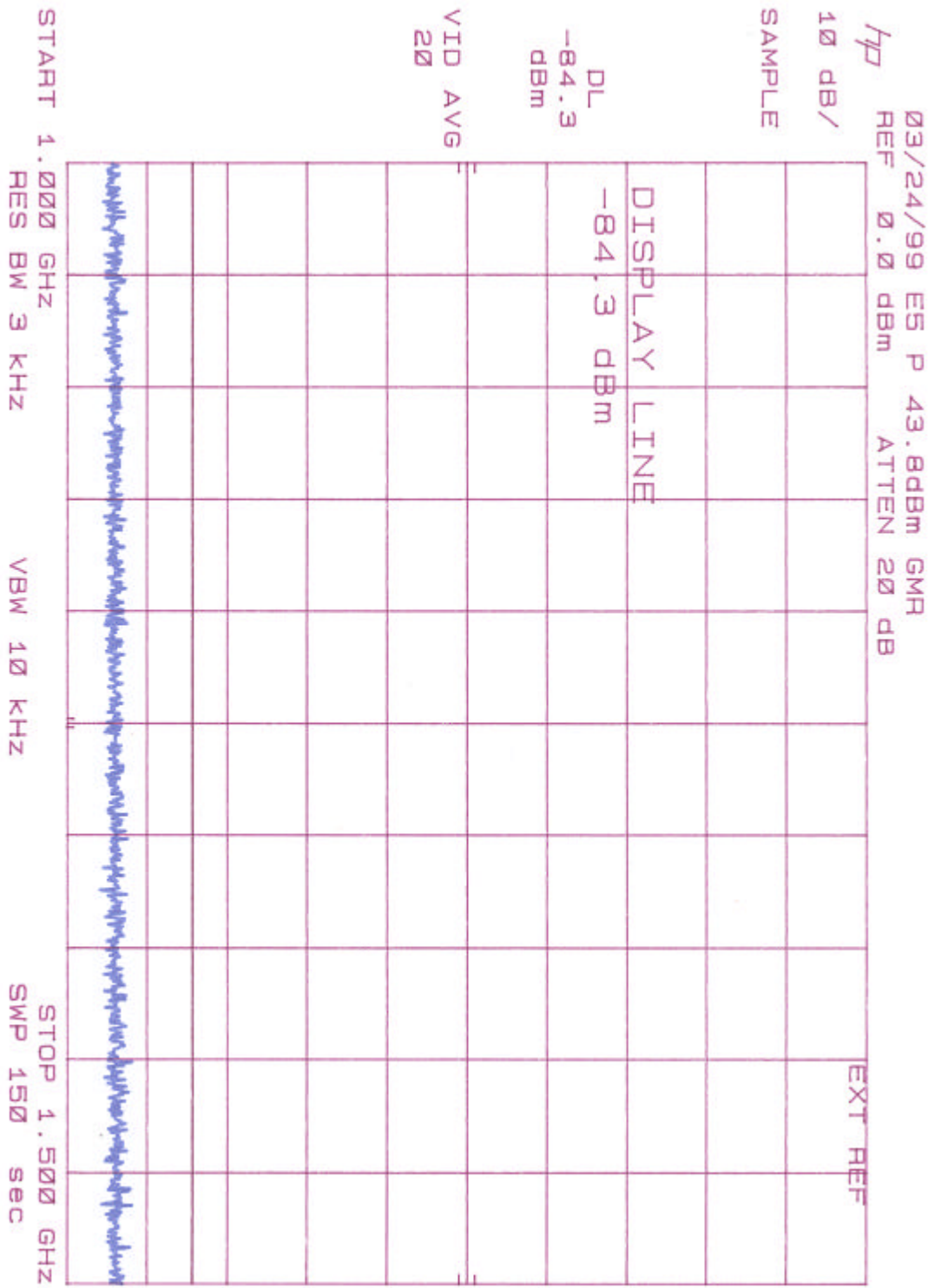

Figure 9.7.2.7 Spurious Emissions – Frequency Span 1.0 – 1.56 GHz

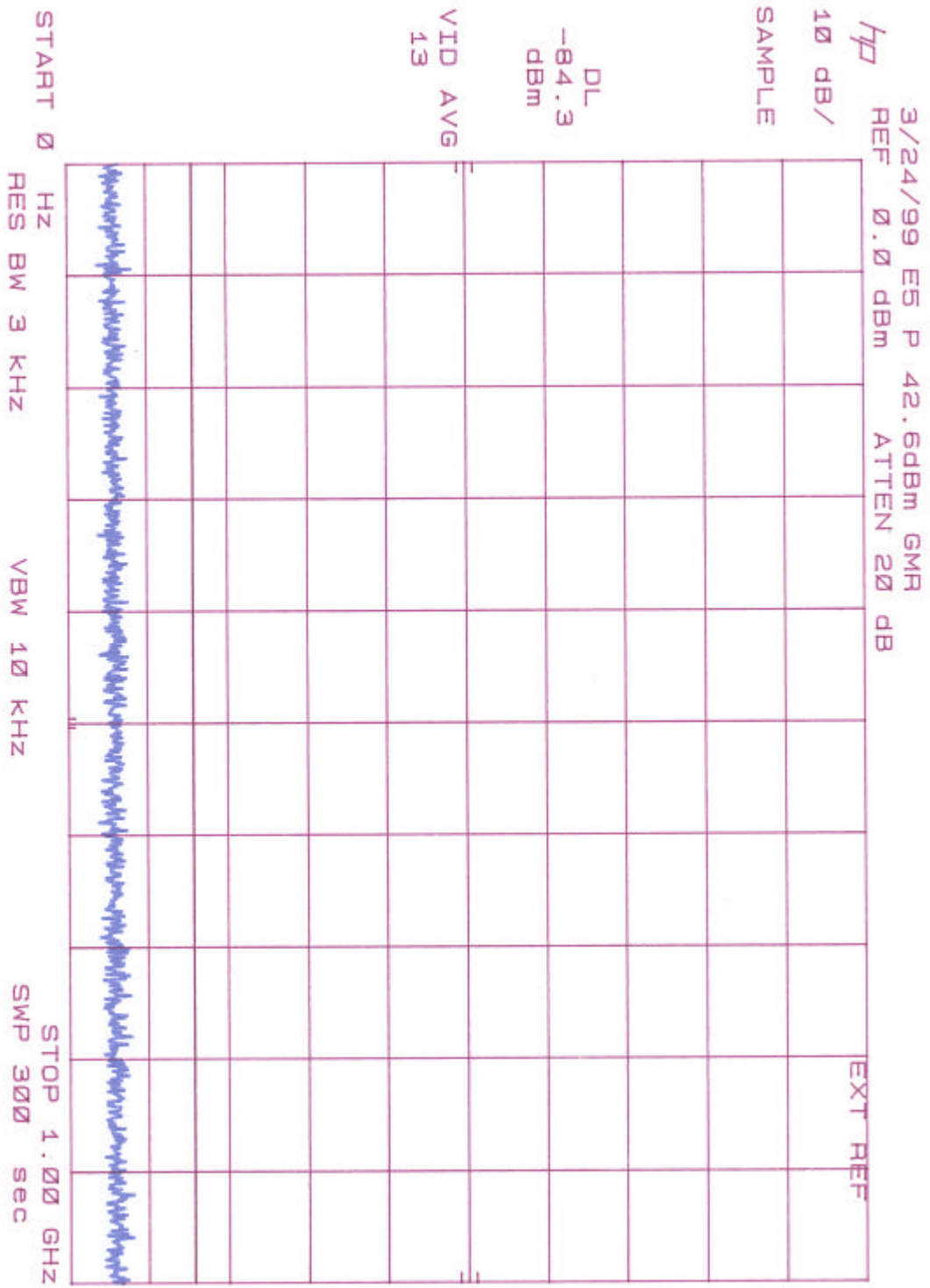

Figure 9.7.2.8 Spurious Emissions – Frequency Span 0 – 1.0 GHz

9.7.3 Intermodulation Test Results

The SAT-2000 system is capable of transmitting multiple carriers. In this configuration, the requirements of 87.139(i)(2) apply. This section demonstrates compliance to these requirements.

Section 87.139(i) (2) states that when transmitting two unmodulated carriers, each 3 dB below the rated power, the mean power of any intermodulation products must be at least 24 dB below the mean power of either carrier.

The intermodulation products of two unmodulated carriers were measured when the SRT-2000 was configured to output 12.5 watts of power in each carrier. This test was repeated with high-, mid-, and low-band frequencies and with representative frequency separations. The results, summarized below, indicate that intermodulation is better than 24dBc for all test cases. All table entries are the intermodulation values.

Frequency Separation	High Band Carrier Frequency (1660 MHz)	Mid Band Carrier Frequency (1643 MHz)	Low Band Carrier Frequency (1627 MHz)
10 kHz	-33.67	-36.00	-31.33
100 kHz	-35.50	-35.83	-32.00
1 MHz	-37.17	-36.17	-33.50
14 MHz	-32.70	-39.30	-35.90

The following spectrum analyzer plots show the intermodulation product component values shown in the above table.

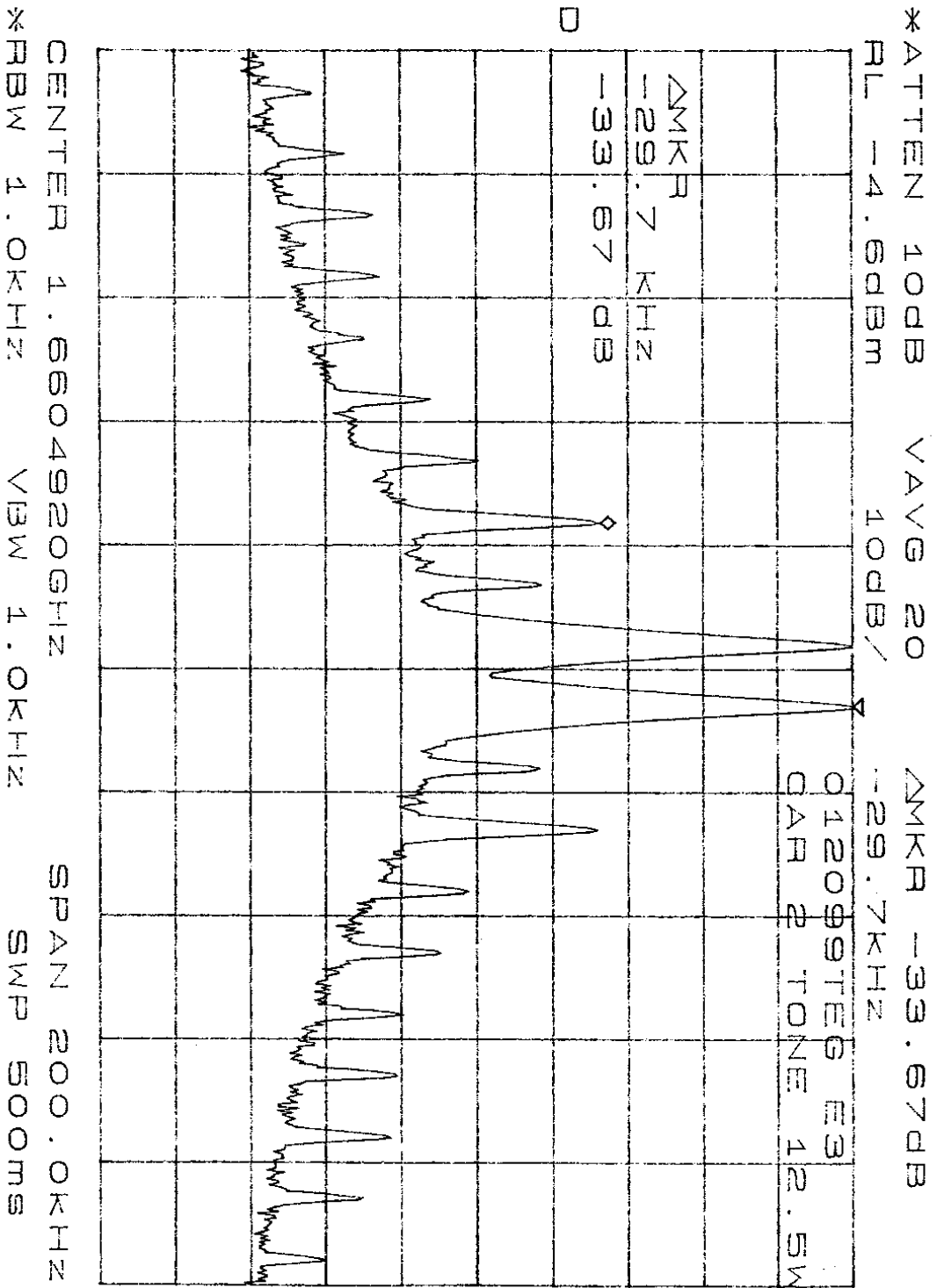

Figure 9.7.3.1 Intermodulation Product Test – 10 kHz Separation, High Band

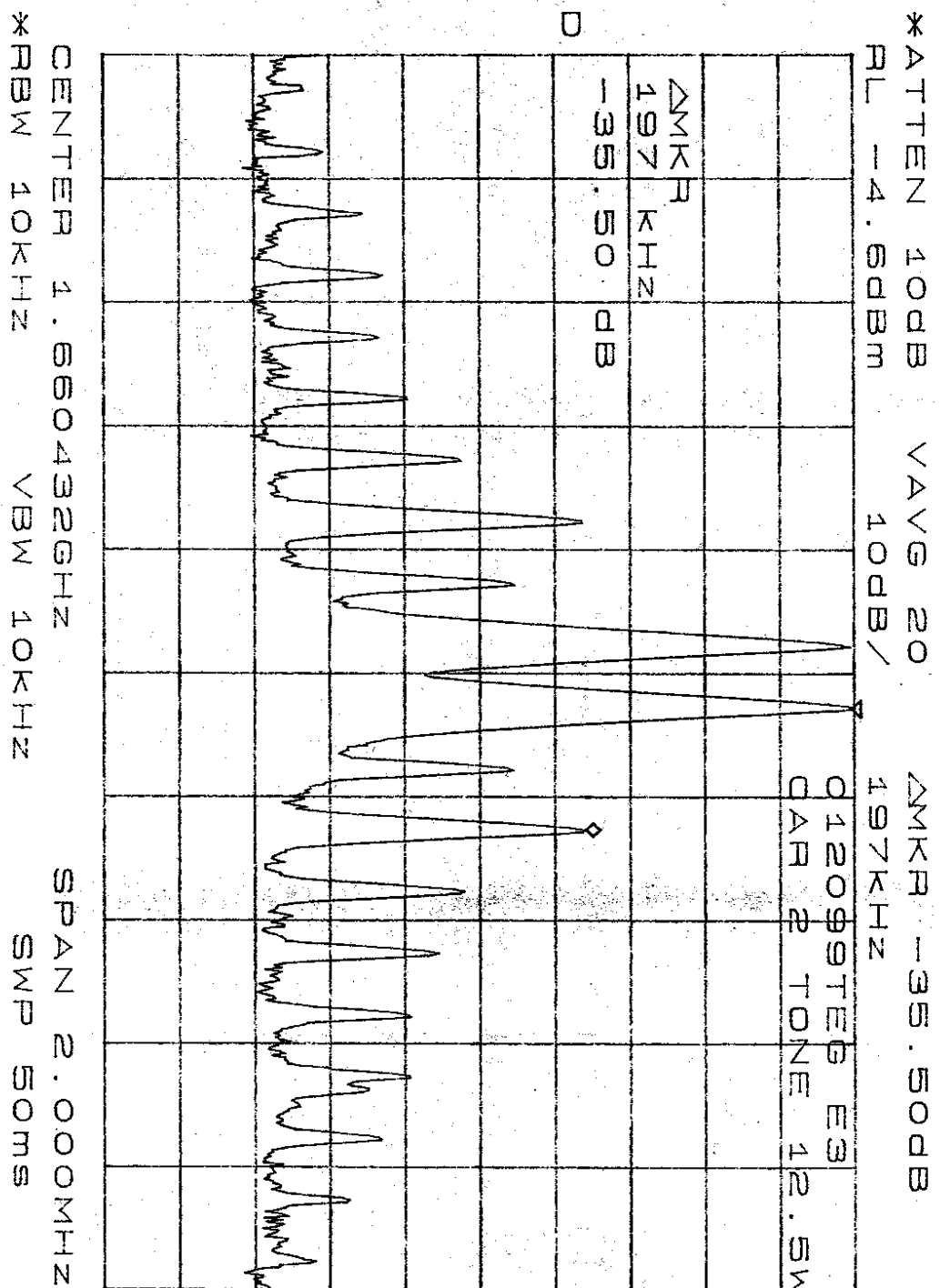

Figure 9.7.3.2 Intermodulation Product Test – 100 kHz Separation, High Band

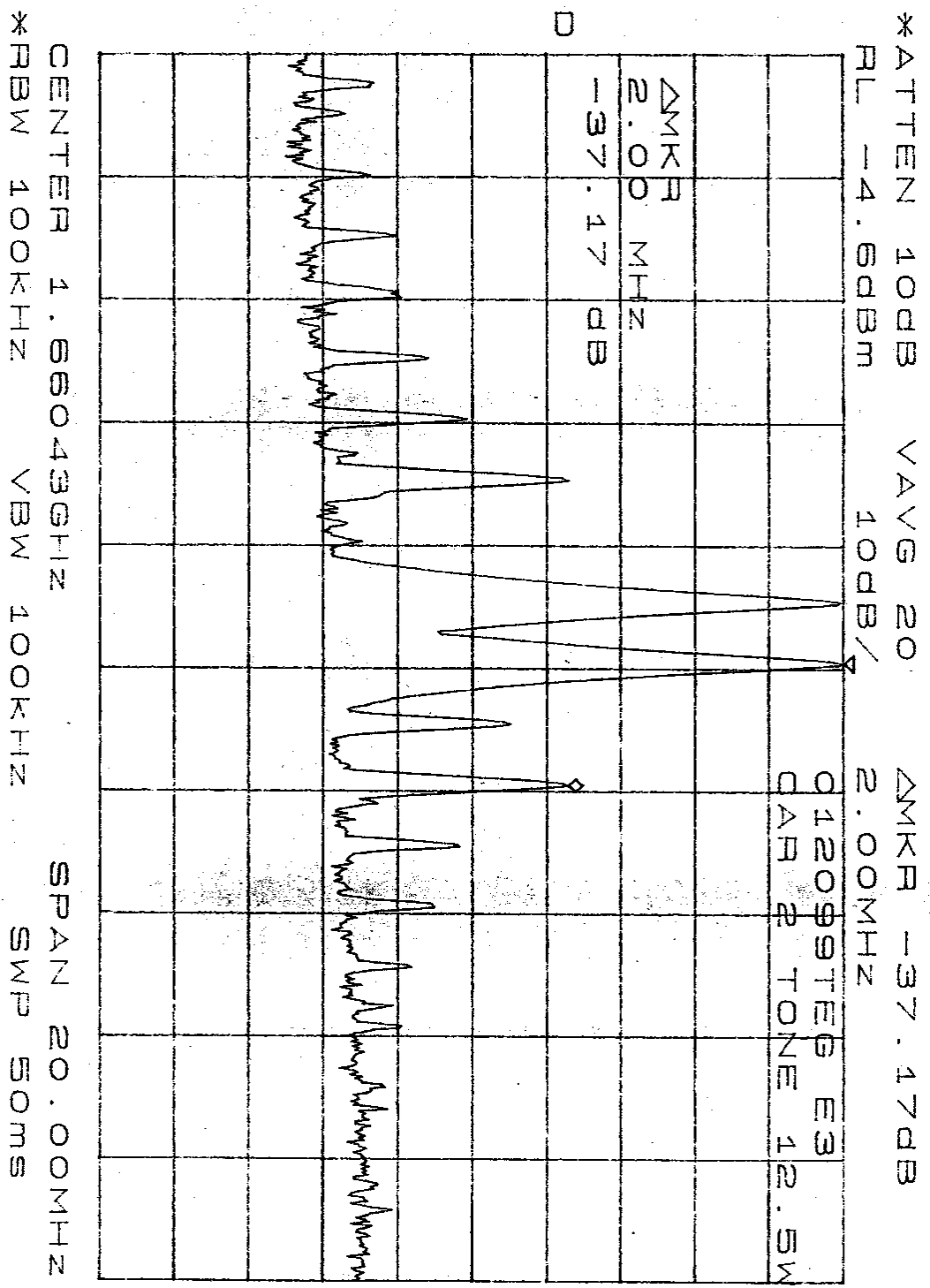

Figure 9.7.3.3 Intermodulation Product Test – 1 MHz Separation, High Band

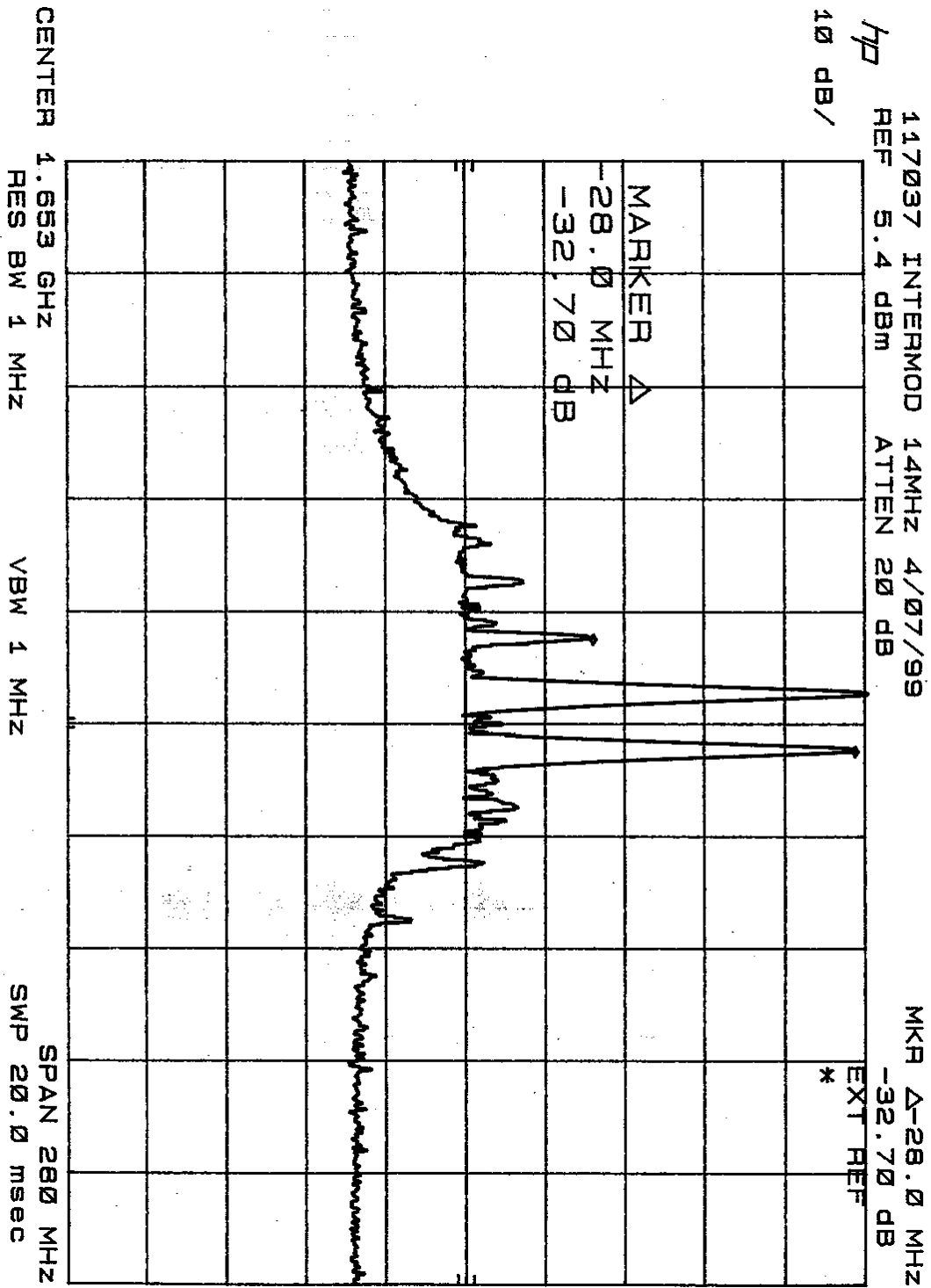

Figure 9.7.3.4 Intermodulation Product Test – 14 MHz Separation, High Band

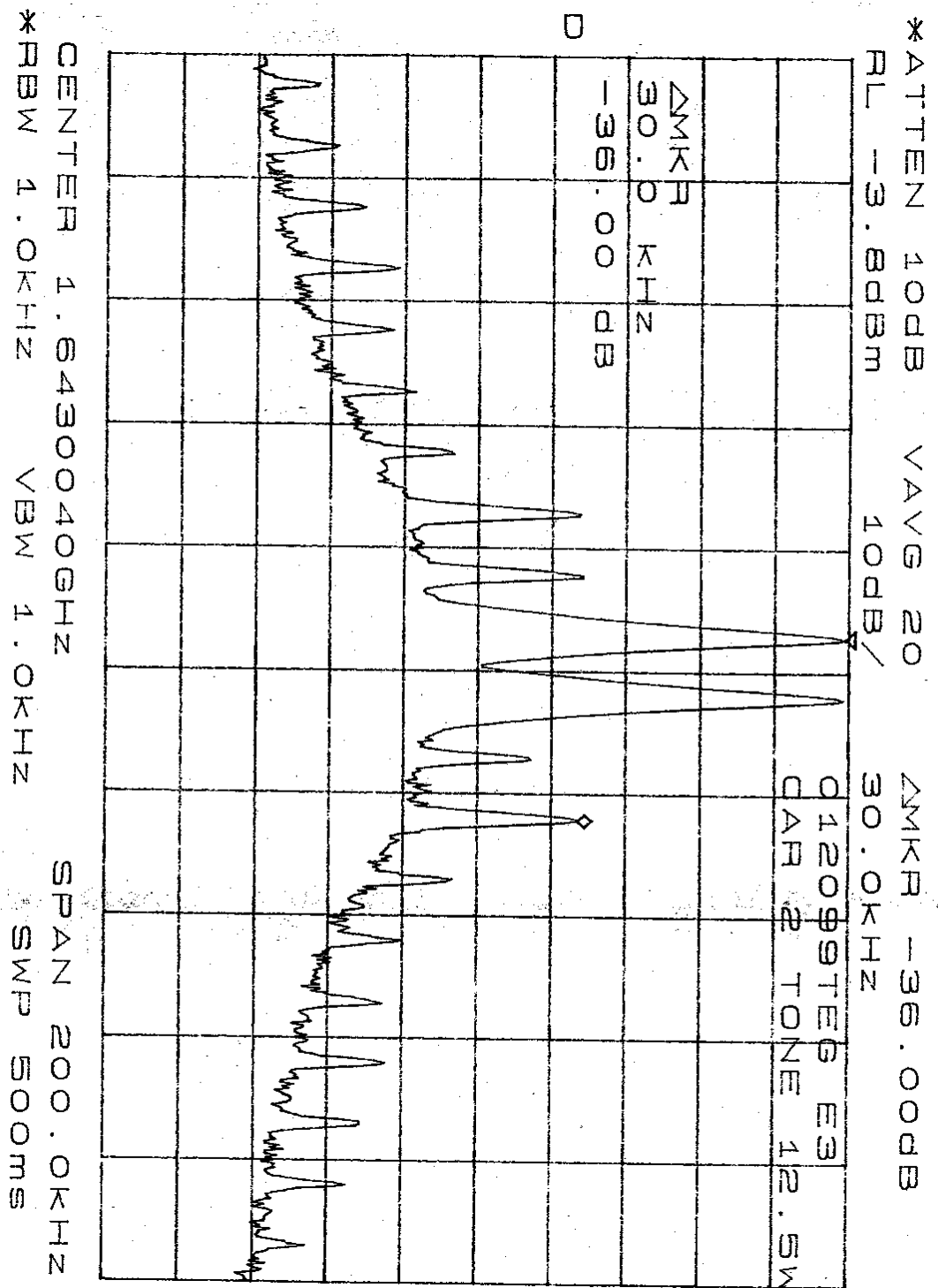

Figure 9.7.3.5 Intermodulation Product Test – 10 kHz Separation, Mid Band

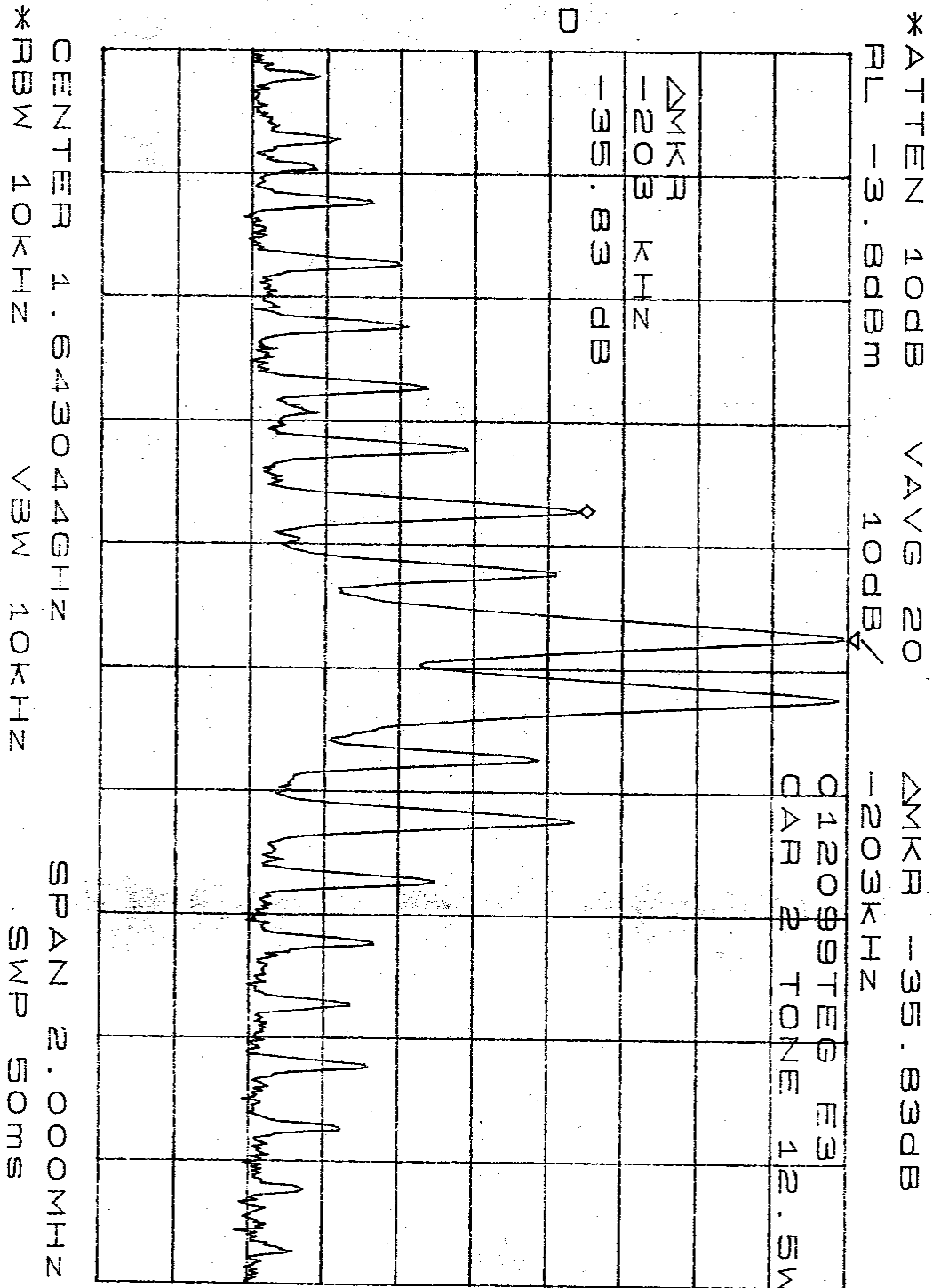

Figure 9.7.3.6 Intermodulation Product Test – 100 kHz Separation, Mid Band

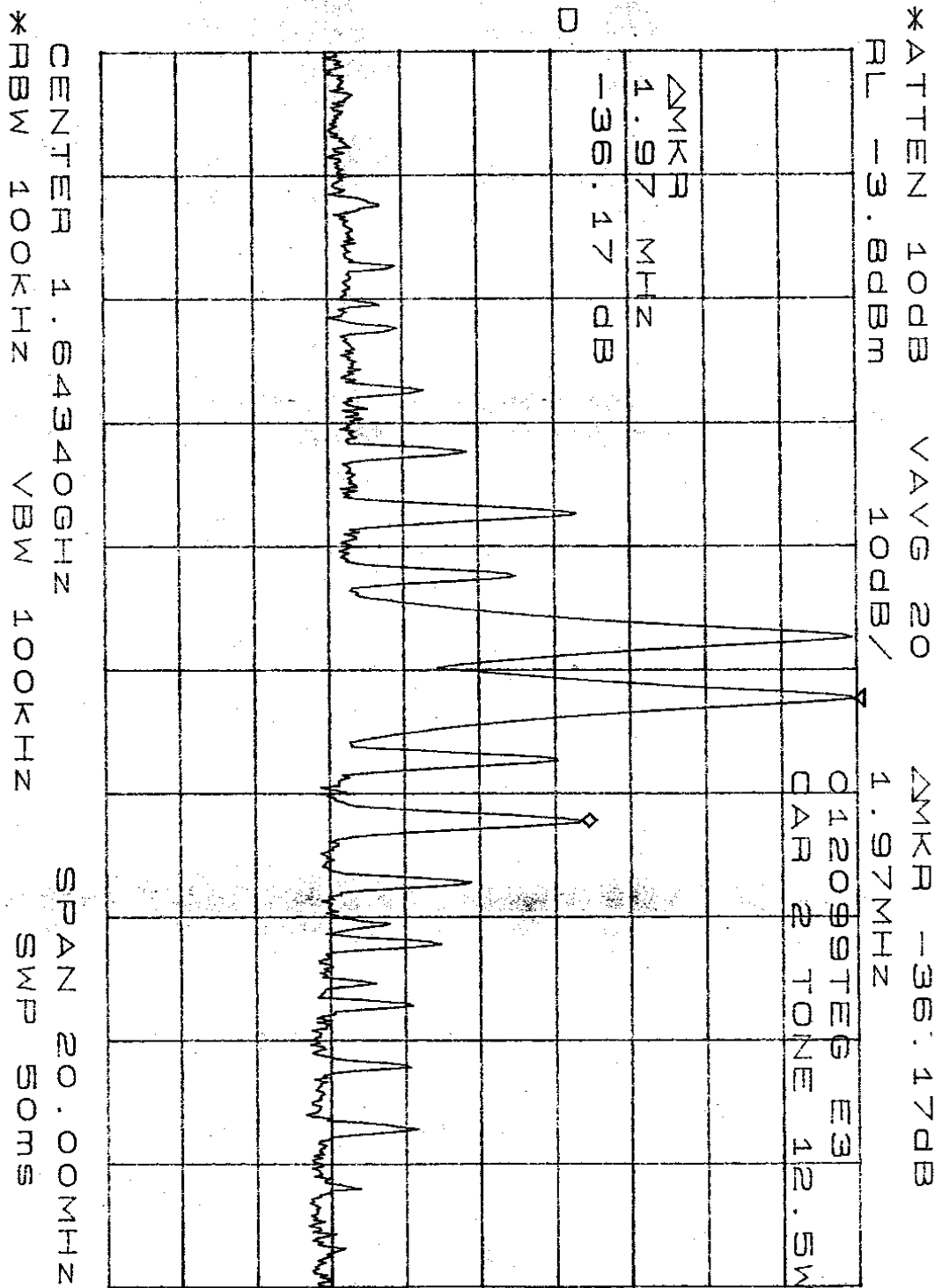

Figure 9.7.3.7 Intermodulation Product Test – 1 MHz Separation, Mid Band

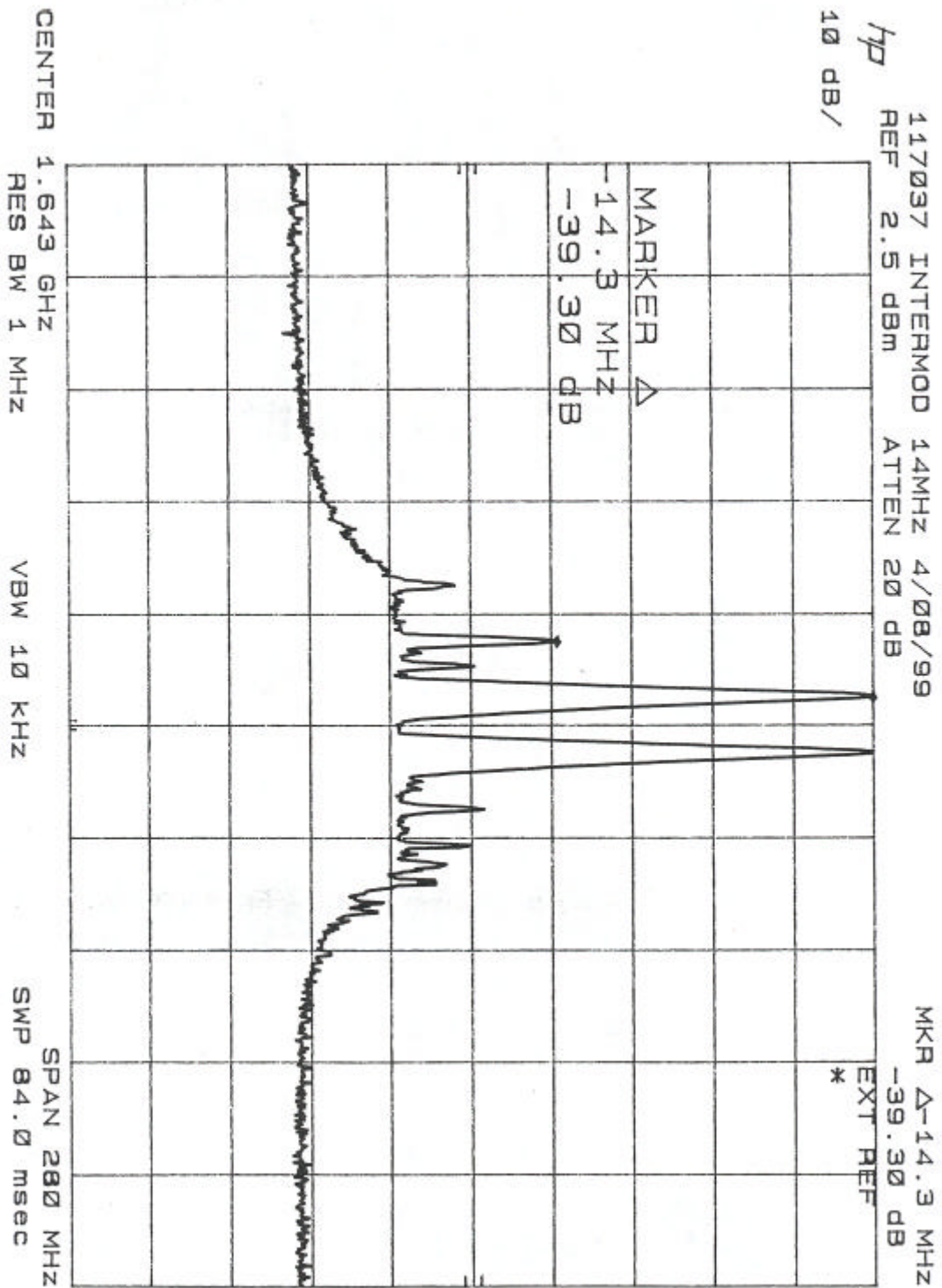

Figure 9.7.3.8 Intermodulation Product Test – 14 MHz Separation, Mid Band

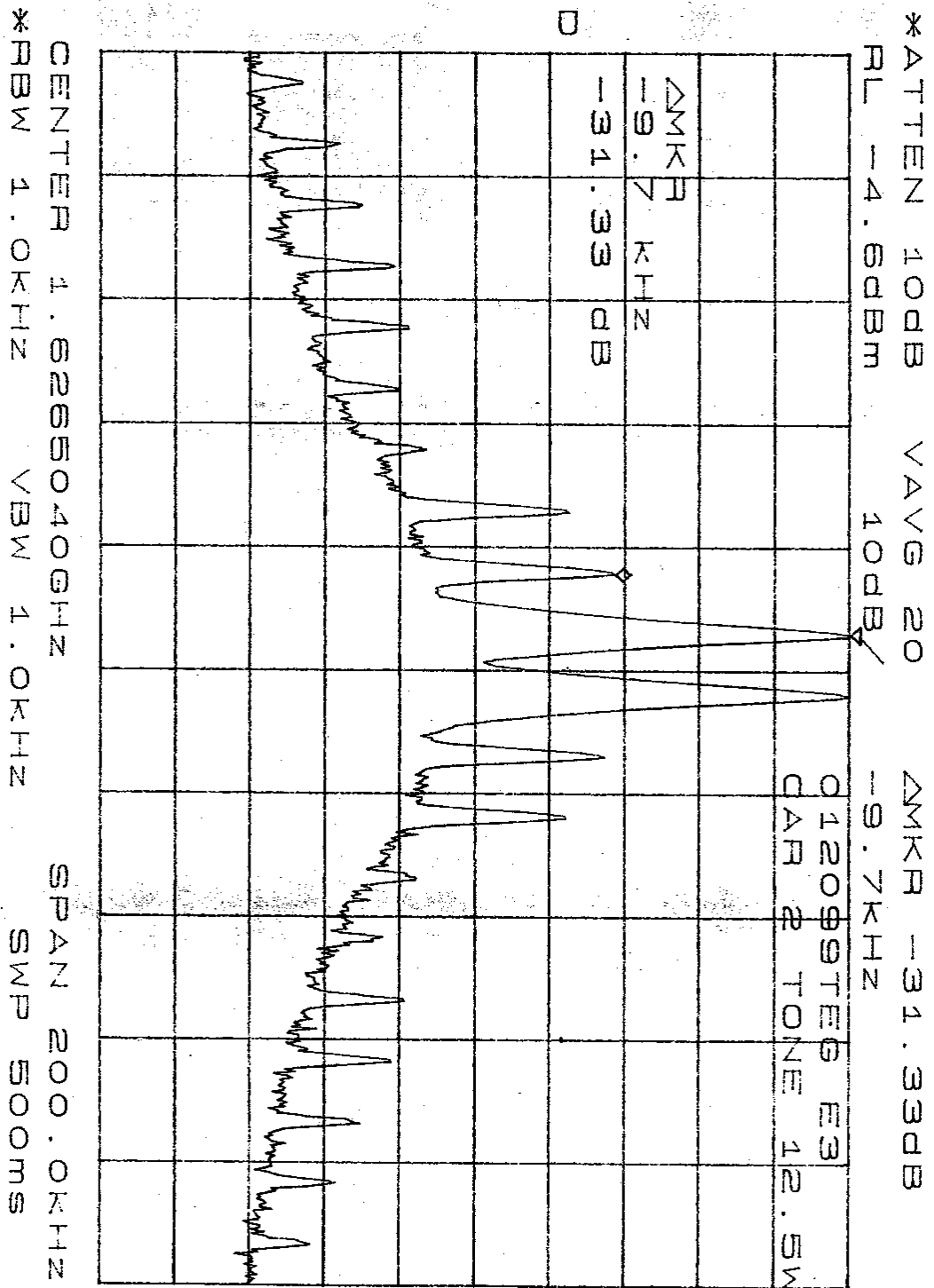

Figure 9.7.3.9 Intermodulation Product Test – 10 kHz Separation, Low Band

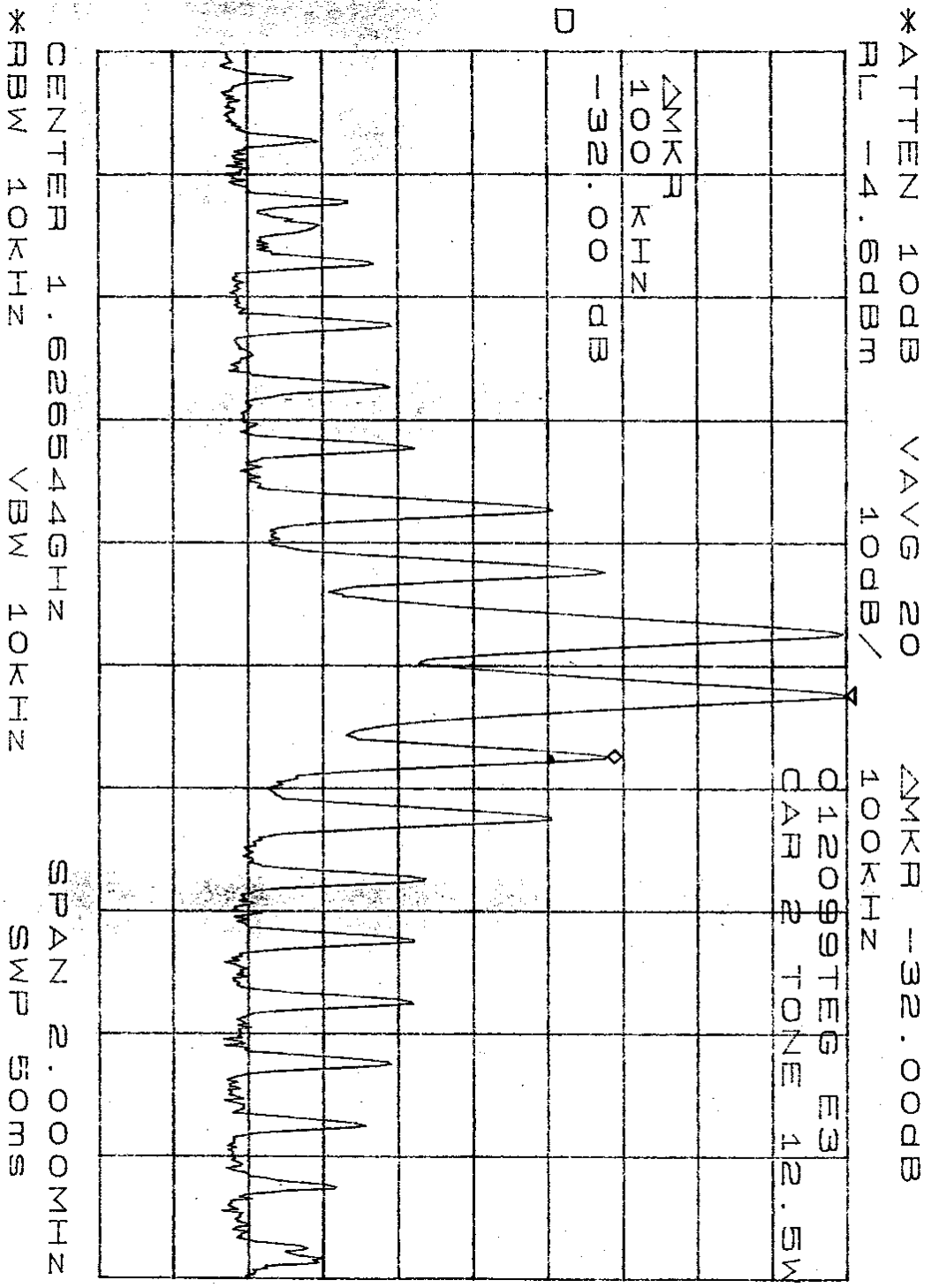

Figure 9.7.3.10 Inter-modulation Product Test – 100 kHz Separation, Low Band

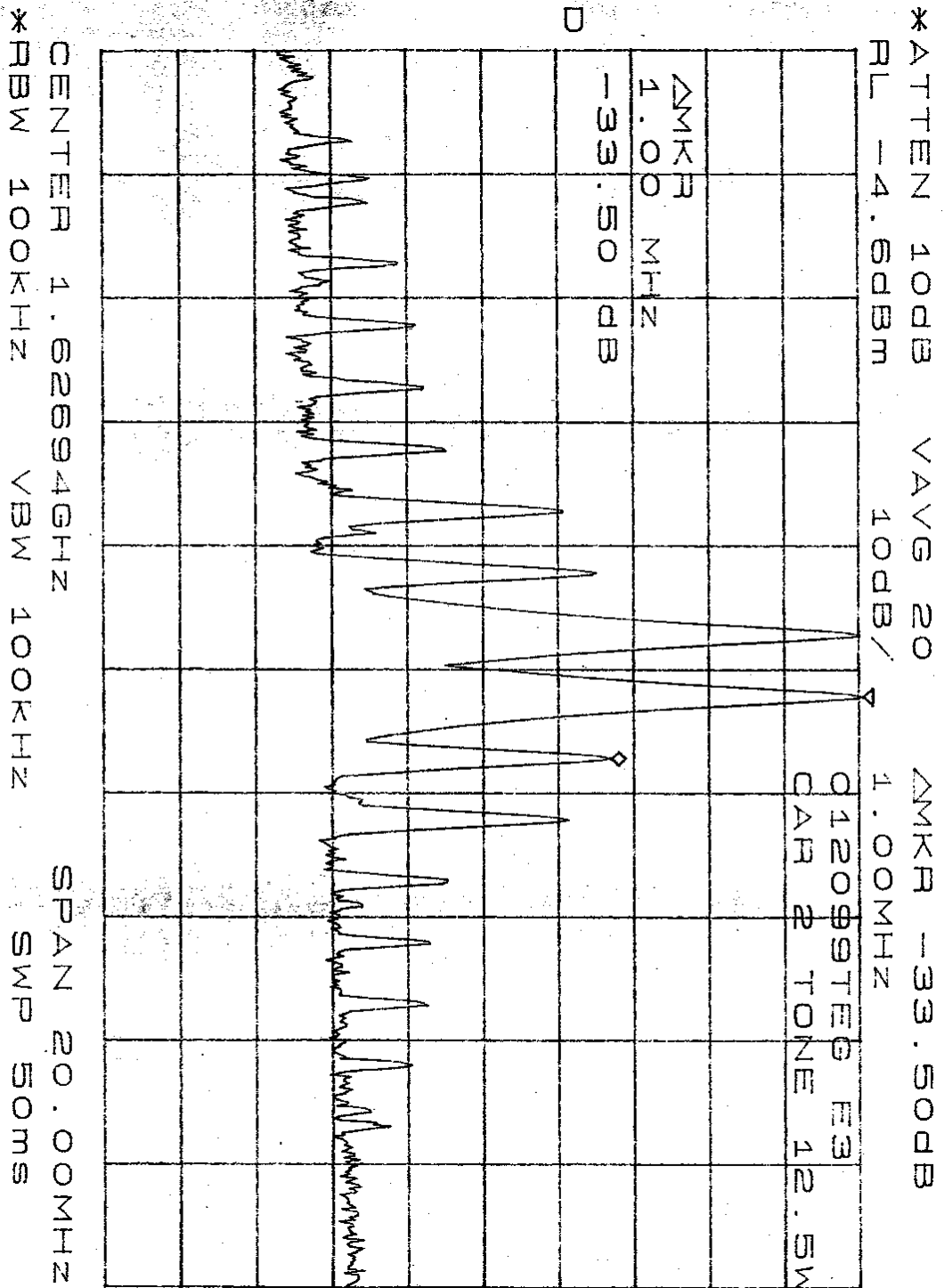

Figure 9.7.3.11 Inter-modulation Product Test – 1 MHz Separation, Low Band

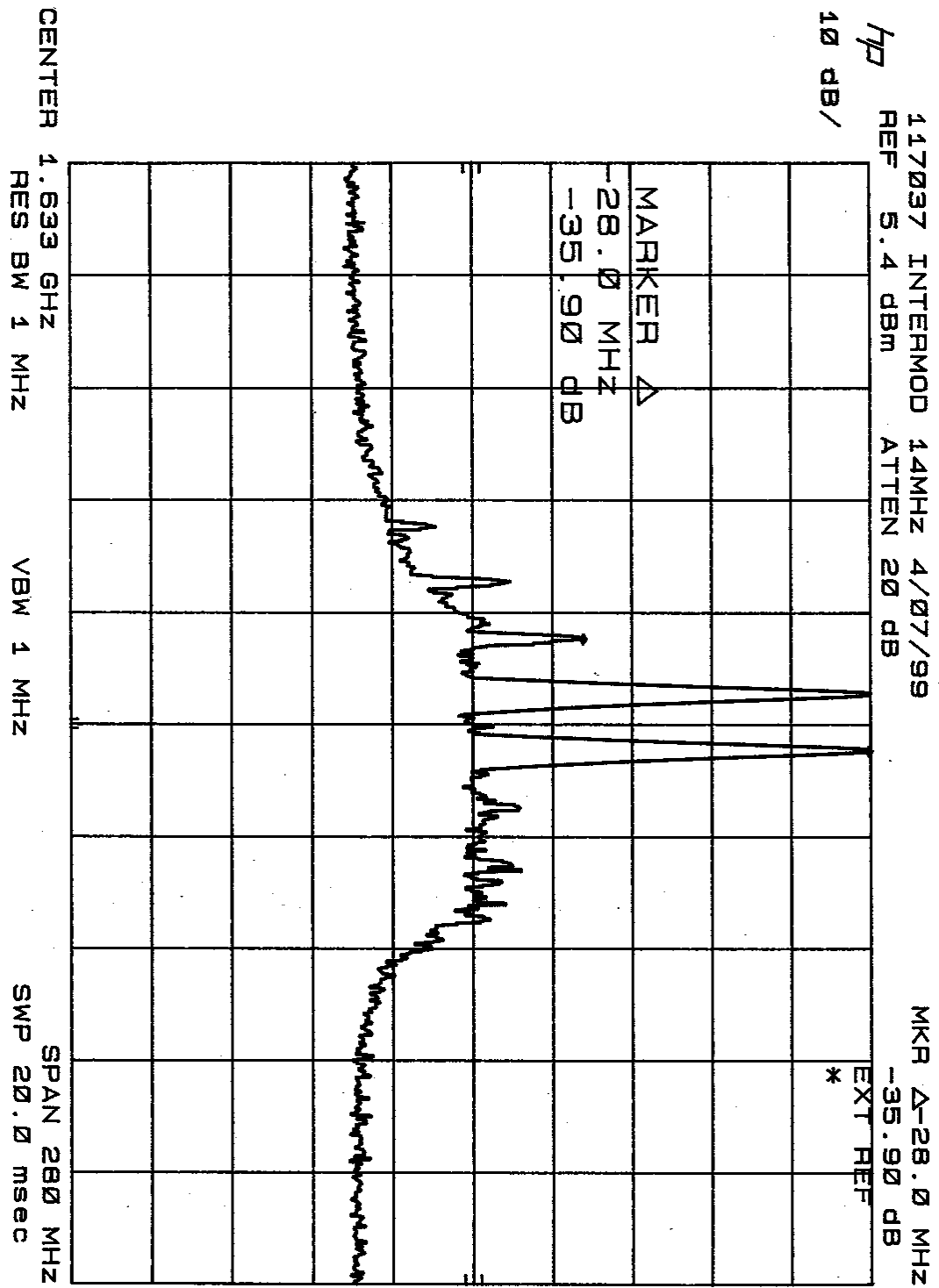

Figure 9.7.3.12 Inter-modulation Product Test – 14 MHz Separation, Low Band

9.8 Field Strength of Spurious Radiation

9.8.1 FCC Requirements

The discussion and test results shown in this section address and meet the requirements of the following FCC requirements.

Section 2.1053 (a), (b) (2) (3)

(a) Measurements shall be made to detect spurious emissions that may be *radiated* directly from the cabinet, control circuits, power leads, or intermediate circuit elements under normal conditions of installation and operation. Curves or equivalent data shall be supplied showing the magnitude of each harmonic and other spurious emissions. Such measurements must be accompanied by a description of the site where the measurements were made showing the location of any possible reflections, which might distort the field strength measurements. Information submitted shall include the relative radiated power of each spurious emission with reference to the radiated power output of the transmitter, assuming all emissions are radiated from halfwave dipole antenna.

(b) The measurements specified in paragraph (a) of this section shall be made for the following equipment:

- (2) All equipment operating on frequencies higher than 25 MHz.
- (3) All equipment where the antenna is an integral part of, and attached directly to the transmitter.

Section 87.139 (i), (1)

(i) In case of conflict with other provisions of Section 87.139, the provisions of this paragraph shall govern for aircraft earth stations. When using G1D, G1E, or G1W emissions in the 1646.5 – 1660.5 MHz frequency band, the emissions must be attenuated as shown below.

(1) At rated output power, while transmitting a modulated single carrier, the composite spurious and noise output shall be attenuated below the mean power of the transmitter, pY, by at least:

Frequency (MHz)	Attenuation (dB) ¹
.005 – 1559	83 or $(65 + 10\log_{10}(pY))$, whichever is greater
1559 – 18000	55 or $(37 + 10\log_{10}(pY))^2$, whichever is greater

¹ these values are expressed in dB below the carrier referenced to a 4 kHz bandwidth and relative to the maximum emission envelope level.

² excluding the frequency band of +/- 35 kHz or +/- 4.00 x Symbol Rate, about the carrier frequency, whichever is the greater exclusion.

9.8.2 Test Procedures

The following procedure is derived from DO-160D, Section 21 and adapted for testing the requirements of section 87.139(i) of FCC Part 87. While RTCA DO-160D does not specify testing above 6 GHz, the same setup and methodology were used to measure radiated emissions up to 18 GHz.

Test Equipment

The following test equipment (or equivalent) shall be used to perform this test:

<u>Equipment</u>	<u>Manufacturer and Model Number</u>	<u>Frequency Range (Bandwidth)</u>
Active whip	RVA-30	10 kHz to 30 MHz
Biconical	EMCO 3104C	25 MHz to 200 MHz
Conical Log Spiral	Stoddart 93490-1	200 MHz to 1 GHz
Double Ridged Guide	EMCO 3115	1 GHz to 18 GHz
Calibrated Cable	RG-400, Adams Russell	NA
LISN	Fischer, FCC-LISN-DO-160	100 kHz - 400 MHz
10 µf Capacitor	Solar 6512-106R	N/A
Spectrum Analyzer	Hewlett Packard, 8566B w/OPT 462	100 Hz - 22 GHz
Preselector	HP 85685A	20 Hz - 2 GHz
Printer	HP Laser Jet	NA
Computer	Gateway 2000	NA
Bus Extender	HP 37204	NA

Conditions

1. Set up the radiated emissions test equipment as shown in Figure 9.8.2.
2. Unit operation during radiate emissions measurements will exercise I/O discrettes, ARINC 429 buses and the RS422 antenna bus via loop-back. In addition, all four analog audio circuits and the CEPT-E1 circuit will be tested using loop-backs through individual channel modules. An RF loop-back through a channel module will be performed to check the transmit and receive path, and a CW carrier will be enabled for monitoring.

Measurements

1. Measure and record emissions over the range from 150 kHz to 18,000 MHz using the automated emissions measurement system.
2. Change antennas as required.

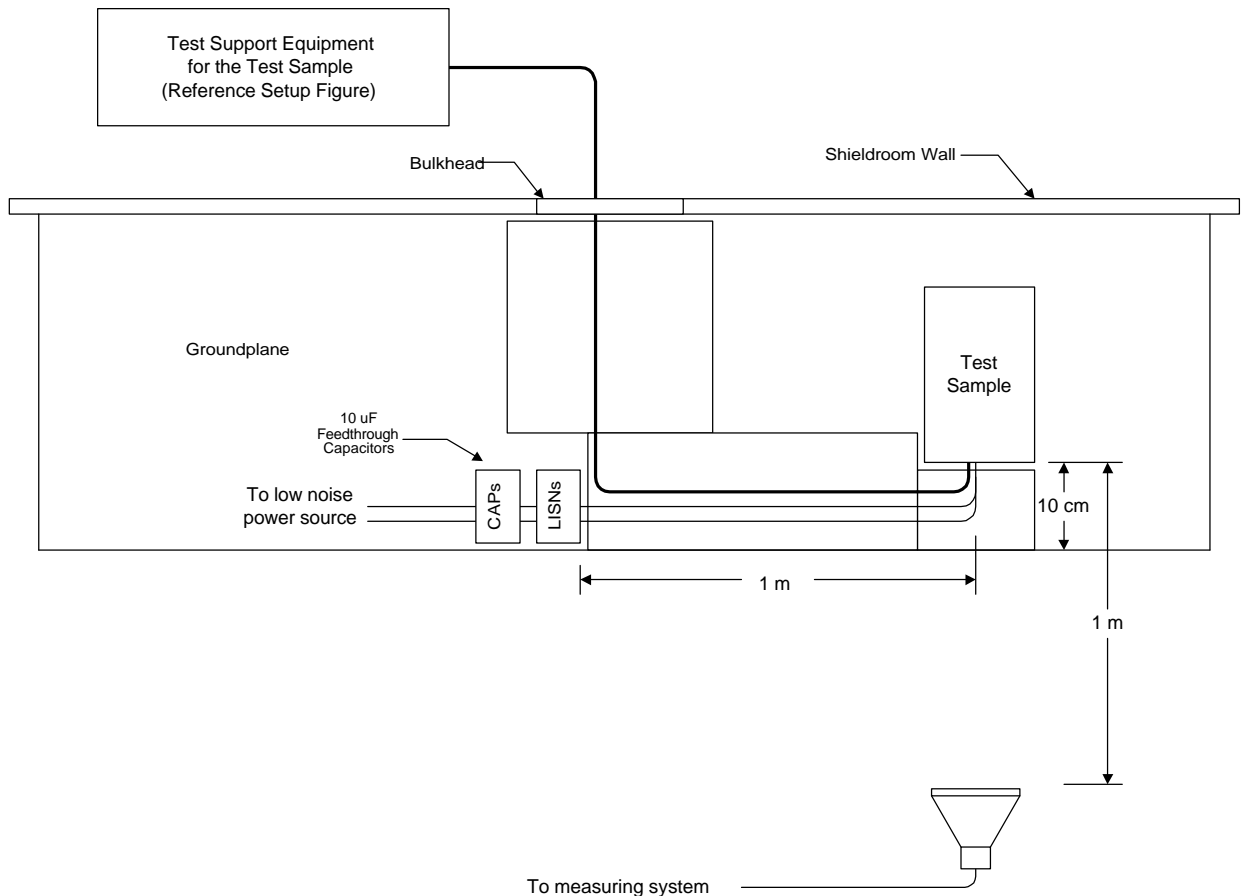

Figure 9.8.2 Typical Test Setup for DO-160D, Paragraph 21.4 Radiated RF Interference

Notes:

1. Terminate all LISN monitor output terminals with 50 ohms.

2. DC Bond resistance between the groundplane and enclosure shall not exceed 2.5 milliohms.
3. The lengths of the power leads from the test sample to the LISNs shall not exceed 1 meter.
4. Excess interconnect cable bundle length will be zigzagged at the back of the test bench, approximately 5 cm above the ground plane. At least 1 meter of EUT cable is to be 10 cm from the front of the test bench and parallel to its front edge.

Reference Field Level Calculations

According to Section 87.139 (i), the radiated spurious emissions are to be attenuated to the same degree as the spurious emissions at the antenna terminals. A reference field level was calculated for comparison with the measured narrow-band data and based on these requirements. The following assumptions were made for these calculations:

1. The intended transmitted signal is radiated through a dipole antenna at 1-meter distance from the point at which the measurements are made.
2. This distance is sufficiently greater than the distance at which the radial component of the E-field is negligible.
3. The peak power available at the dipole antenna is calculated with maximum cable loss at the rated output power. This power would be 16.02 dBW (40 watts) – 2.5 dB (cable loss) = 13.52 dBW (22.49 watts).
4. The duty cycle of the operation is 100%.
5. Section 87.139(i) attenuation requirement is 83 dB.
6. The calculation proceeded as follow:

For a half-wave dipole antenna in free space, in the direction of maximum radiation, the field strength is

$$E = (49.2 * P_t)^{0.5} / R$$

Where

R = distance in meters

P_t = transmitted power in watts

For a distance of $R = 1$ meter and the transmitted power of 14.06 watts, the field strength is calculated to be:

$$E = (49.2 * 14.06)^{0.5} / 1 = 26.30 \text{ Volts/meter} = 26.30 * 10^6 \text{ Micro-Volts/meter} = 148.40 \text{ dBuV/meter.}$$

The maximum field strength of the radiated spurious component is then:

$$148.40 \text{ dBuV/M} - 83 \text{ dB} = 65.40 \text{ dBuV/M} (.005 - 1559 \text{ MHz}) \text{ and } 148.40 \text{ dBuV/M} - 55 \text{ dB} = 93.40 \text{ dBuV/M} (1559 - 18000 \text{ MHz}).$$

The following data show that all spurious emissions are lower than the limit indicated above.

DO-160D CATEGORY M RADIATED EMISSIONS

RADIATED EMI (2 MHz-1GHz)

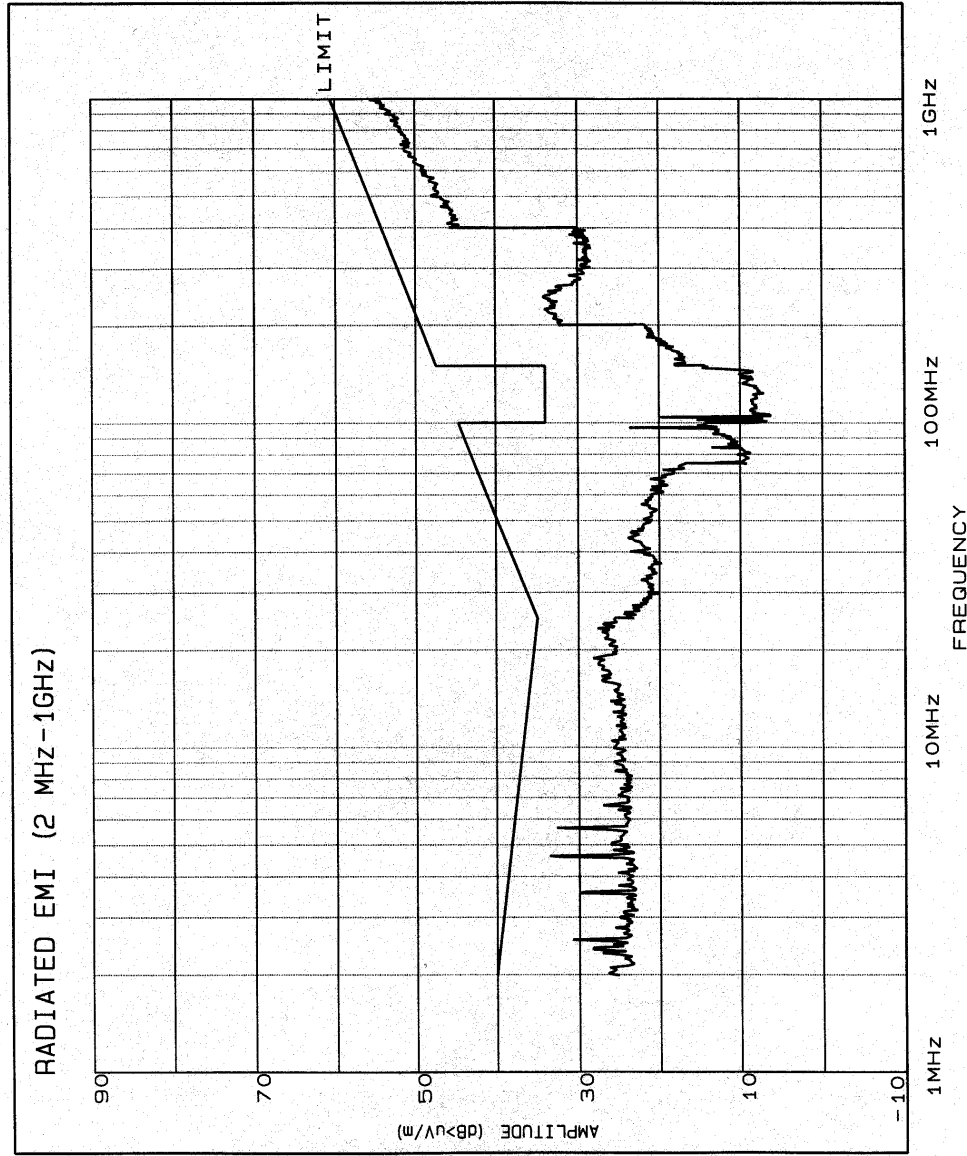

UNIT UNDER TEST

SRT-2000

TEST CONDITION or MODE

ON

PROCEDURE PARA. #

2.8.2

DATE

17 Jun 1999

TECHNICIAN

15786

SERIAL #

117045

ANTENNAS:

RVA 30 460-0113-398

EMCO 3104C 460-0115-516

HORIZONTAL

EMCO 3101 460-0113-396

85668 85685A

PLOT #C99061718

ROOM #9

1600_RAD 08 OCT 1998

DO-160D CATEGORY M RADIATED EMISSIONS

RADIATED EMI (2 MHz-1GHz)

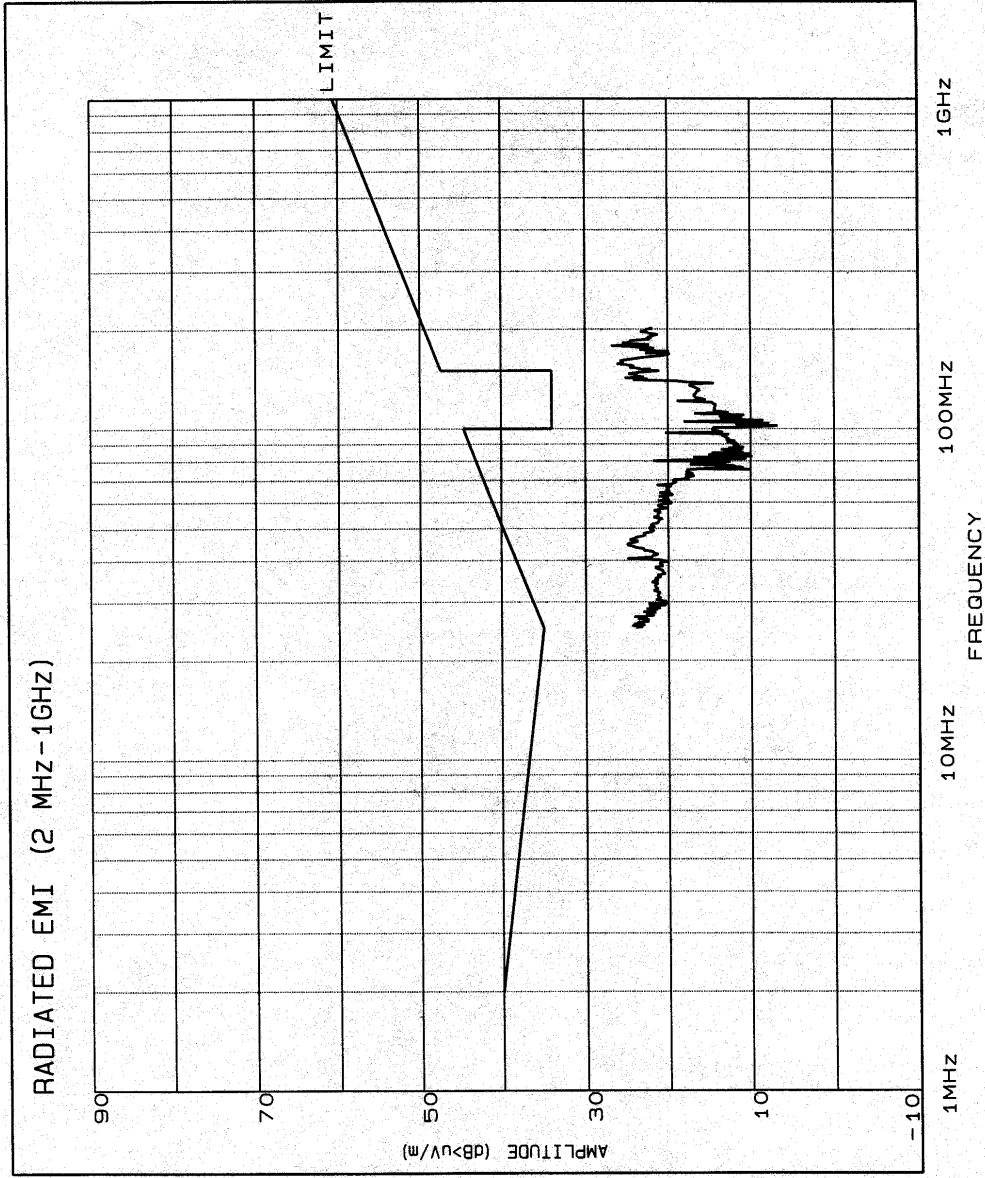

UNIT UNDER TEST

SRT-2000

TEST CONDITION or MODE

ON

PROCEDURE PARA. #

2.8.2

DATE

17 Jun 1999

TECHNICIAN

15786

SERIAL #

117045

ANTENNAS:

RVA 30 460-0113-398

EMCO 3104C 460-0115-516

VERTICAL

EMCO 3101 460-0113-396

85668 85685A

PLOT #C99061719

ROOM #9

1600_RAD 08 OCT 1998

D0-160D CATEGORY M RADIATED EMISSIONS

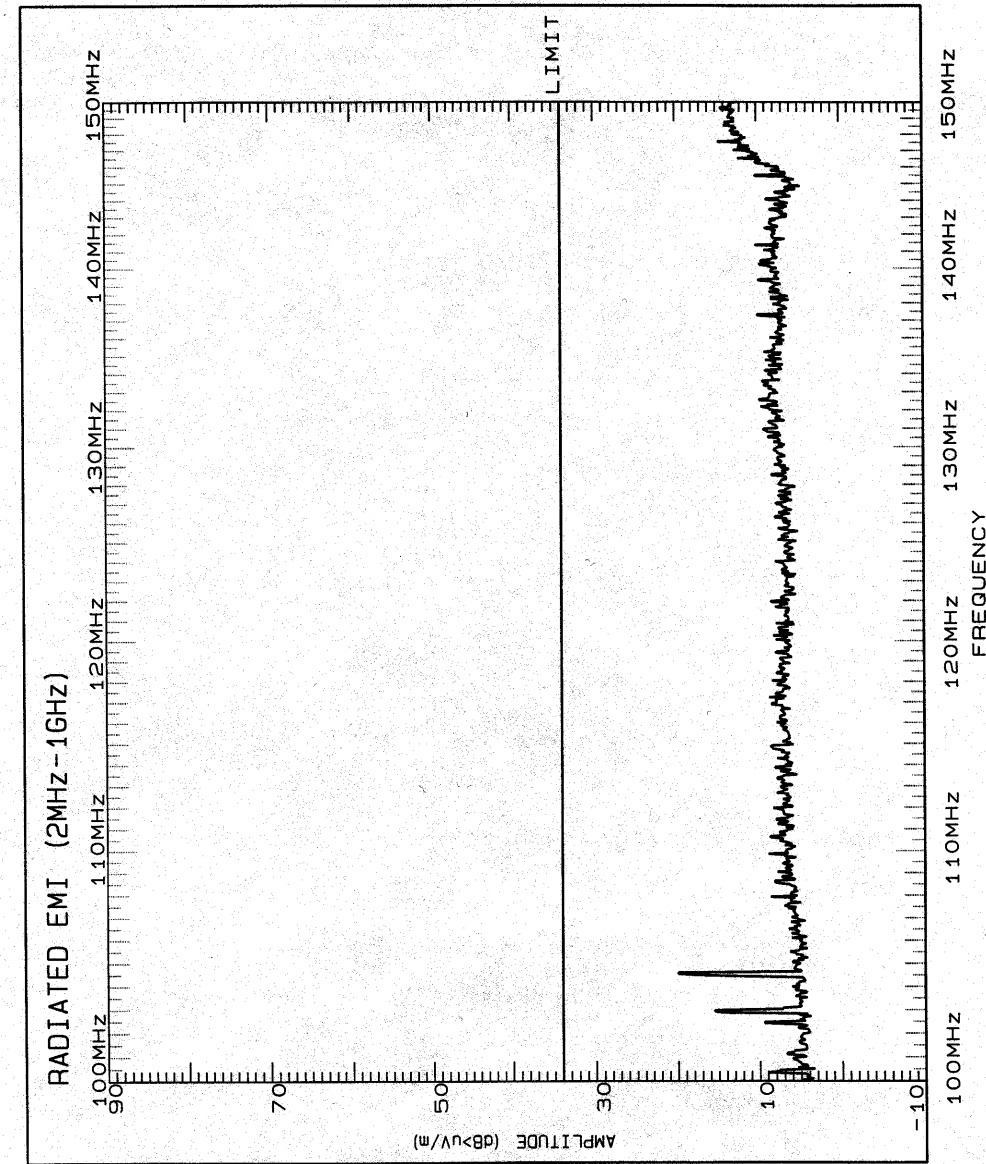

UNIT UNDER TEST

SRT-2000

TEST CONDITION or MODE

ON

PROCEDURE PARA. #

2.8.2

DATE

17 Jun 1999

TECHNICIAN

15786

SERIAL #

117045

ANTENNAS:

EMCO 3104C 460-0115-516

HORIZONTAL

8566B 85685A

PLOT #C99061720

ROOM #9

160D_RAD 08 OCT 1998

DO-160D CATEGORY M RADIATED EMISSIONS

UNIT UNDER TEST

SRT-2000

TEST CONDITION or MODE

ON

PROCEDURE PARA. #

2.8.2

DATE

17 Jun 1999

TECHNICIAN

15786

SERIAL #

117045

ANTENNAS:

EMCO 3104C 460-0115-516

VERTICAL

8566B 85685A

PLOT #C99061721

ROOM #9

1600_RAD 08 OCT 1998

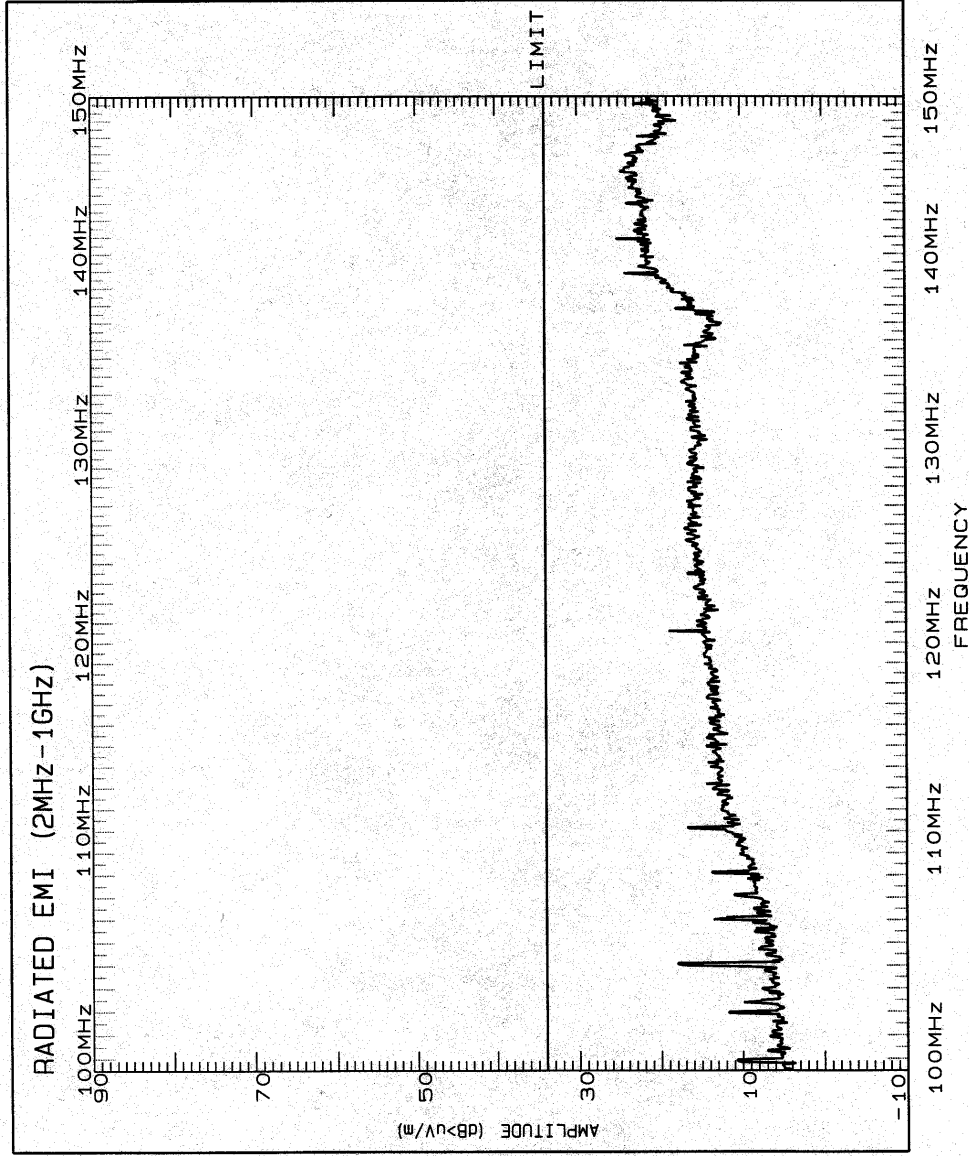

CATEGORY M RADIATED EMISSIONS

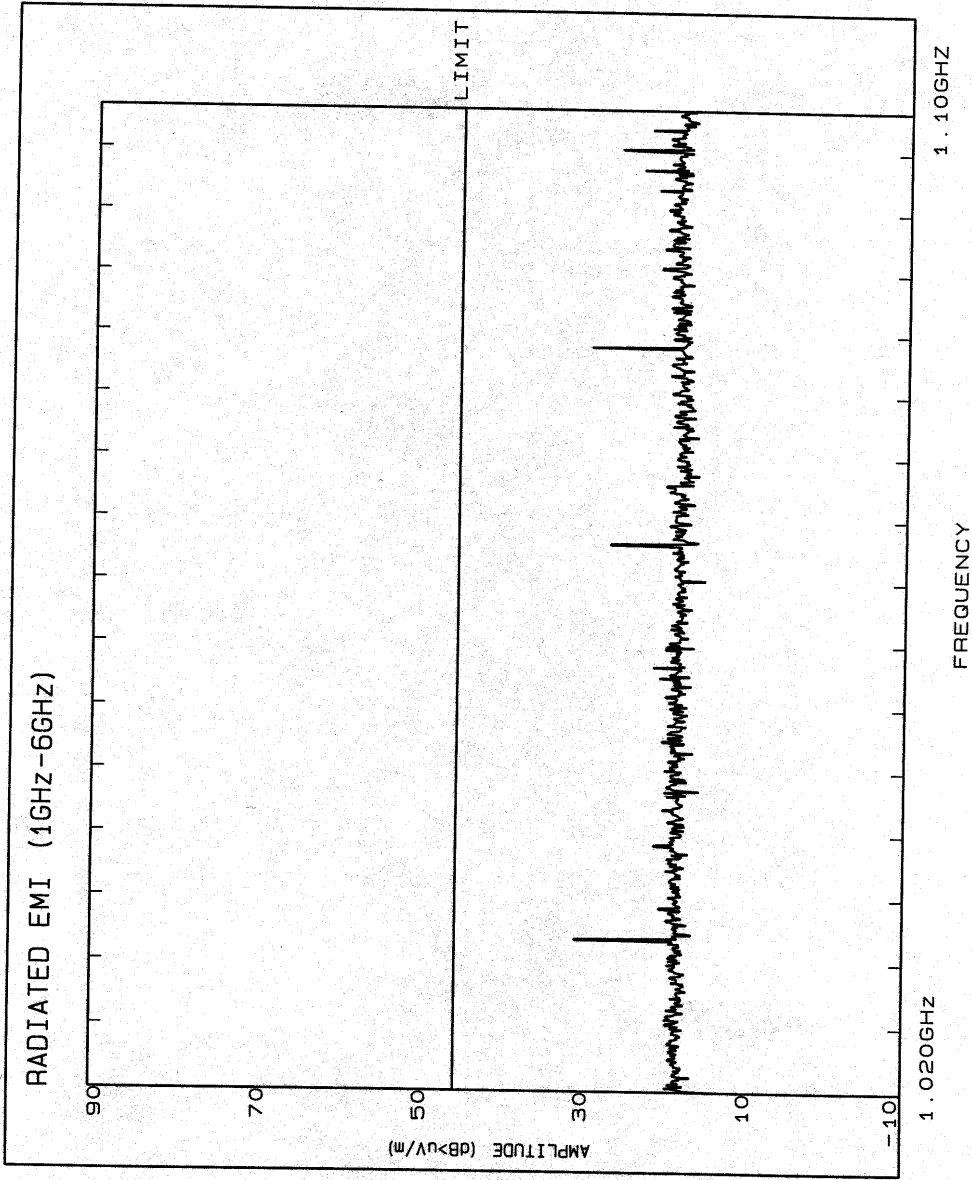

UNIT UNDER TEST

SRT-2000

TEST CONDITION or MODE

ON - *Horizontal*

PROCEDURE PARA. #

2.8.2

DATE

5-19-99

TECHNICIAN

6-17-99
+3674-15785

SERIAL #

117045

ANTENNAS:

EMCO 3115

SERIAL #264B

85685A

PLOT #C99061727

ROOM #5

160_GHZ 10 DEC 95

CATEGORY M RADIATED EMISSIONS

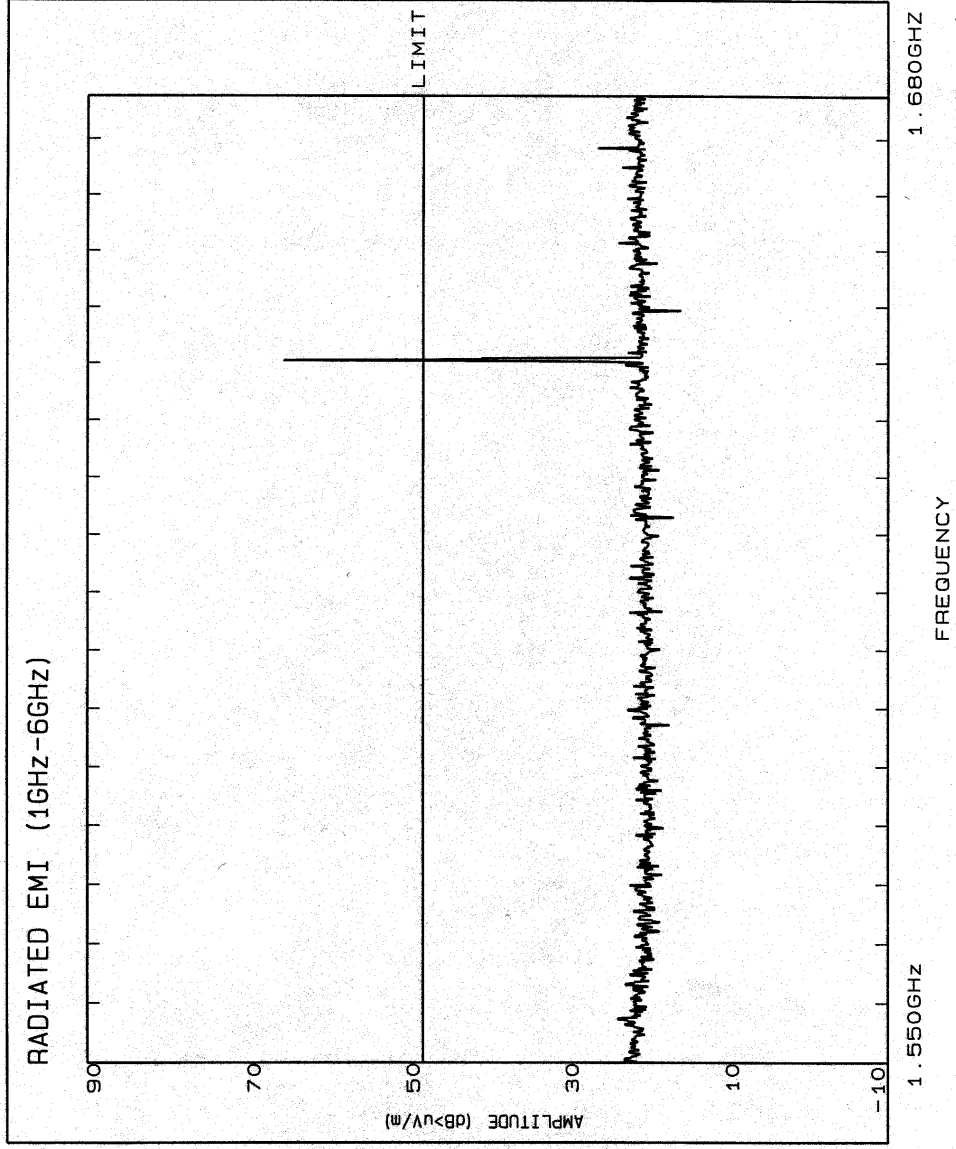

UNIT UNDER TEST

SRT-2000

TEST CONDITION or MODE

ON - Horizontal

PROCEDURE PARA. #

2.8.2

DATE

5-19-99

TECHNICIAN

SM 6-17-99
49674 1586

SERIAL #

117045

ANTENNAS:

EMCO 3115

SERIAL #2648

85685A

PLOT #C99061728

ROOM #5

160_GHZ 10 DEC 95

CATEGORY M RADIATED EMISSIONS

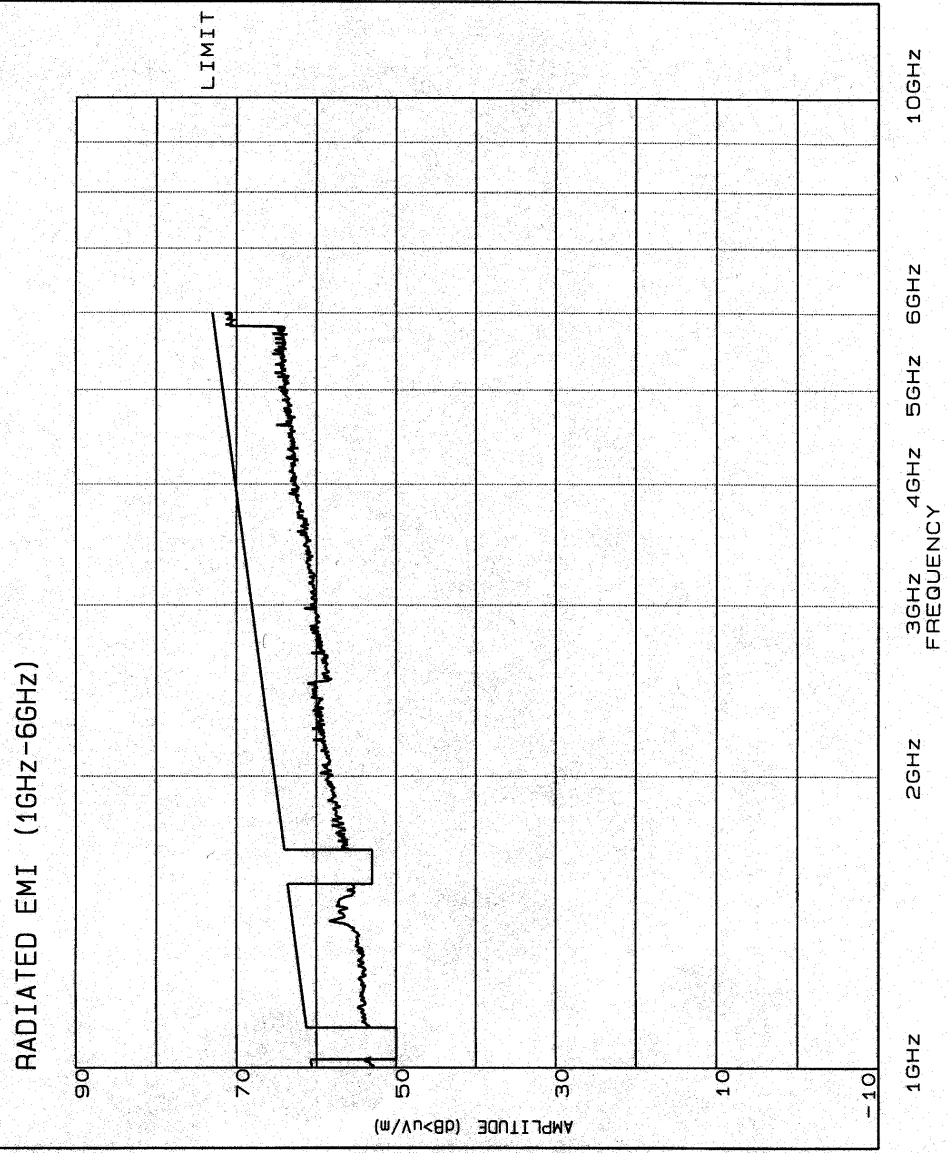

UNIT UNDER TEST

SRT-2000

TEST CONDITION or MODE

ON ~ Horizontal

PROCEDURE PARA. #

2.8.2

DATE

5-19-99

TECHNICIAN

6-17-99
45074, 15786

SERIAL #

117045

ANTENNA:

EMCO 3115

SERIAL #2648

PLOT #C99061729

ROOM #5

1600_GHZ 10 DEC 95

FCC RADIATED EMISSIONS

RADIATED EMI (1GHz-18GHz) NARROWBAND

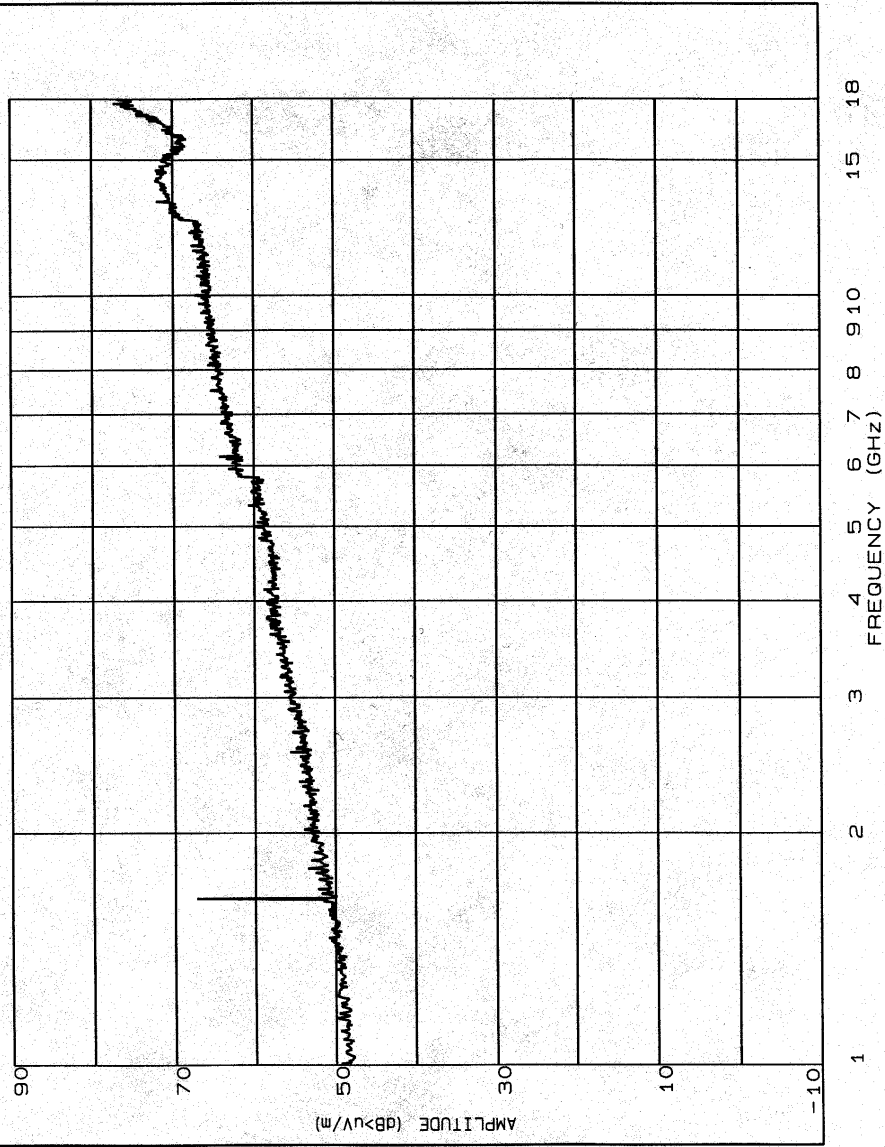

UNIT UNDER TEST

SRT-2000

TEST CONDITION or MODE

ON *Hoeg*

PROCEDURE PARA. #

N/A

DATE

17 JUN 99

TECHNICIAN

18318.

SERIAL #

117045

ANTENNA:

EMCO 3115

SERIAL #264B

PLOT #C99061730

ROOM #9

FCC_RE 18 APR 93

UNIT UNDER TEST

SRT-2000

TEST CONDITION or MODE

ON VERT

PROCEDURE PARA #

N/A

DATE

17 JUN 99

TECHNICIAN

18318

SERIAL #

117045

ANTENNA:

EMCO 3115

SERIAL #2648

PLOT #C99061731

ROOM #9

FCC_RE 18 APR 93

FCC RADIATED EMISSIONS

RADIATED EMI (1GHZ-18GHZ) NARROWBAND

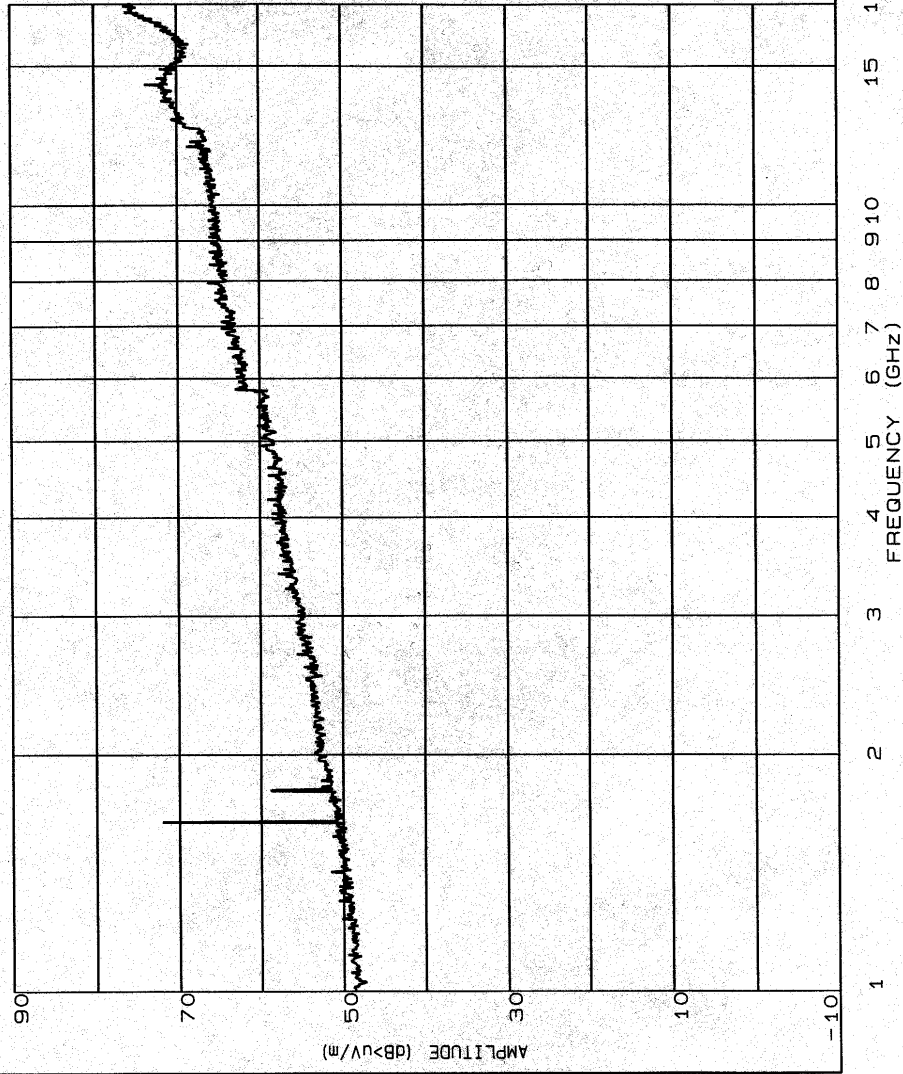

DO-160D CATEGORY M RADIATED EMISSIONS

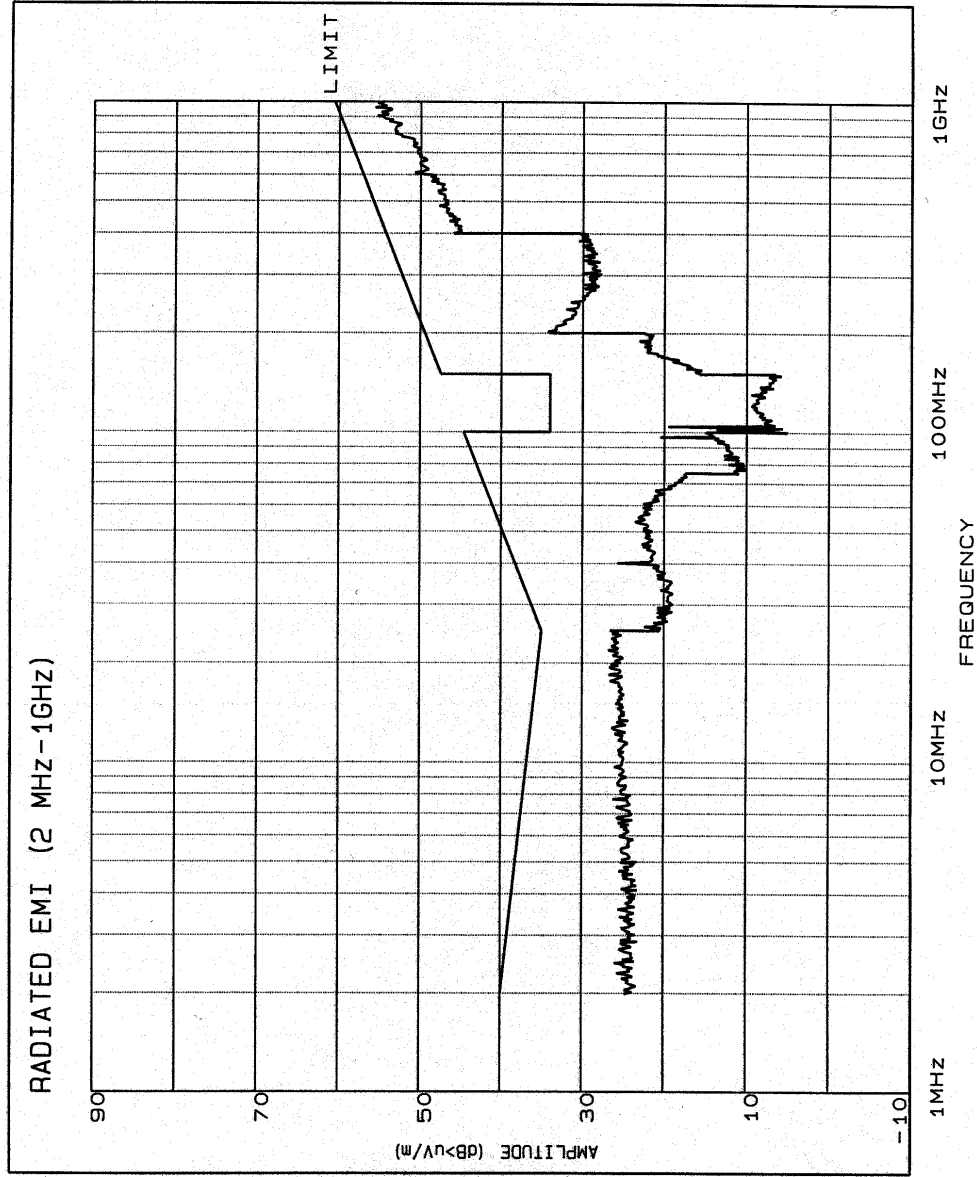

UNIT UNDER TEST

SRT-2000

TEST CONDITION or MODE

AMBIENT

PROCEDURE PARA. #

2.8.2

DATE

14 Jun 1999

TECHNICIAN

16654

SERIAL #

117045

ANTENNAS:

RVA 30 460-0118-546

EMCO 3104C 460-0119-436

HORIZONTAL

STODDART 029-0357-001

85668 85665A

PLOT #C99061416

ROOM #9

160D_RAD 08 OCT 1998

DO-160D CATEGORY M RADIATED EMISSIONS

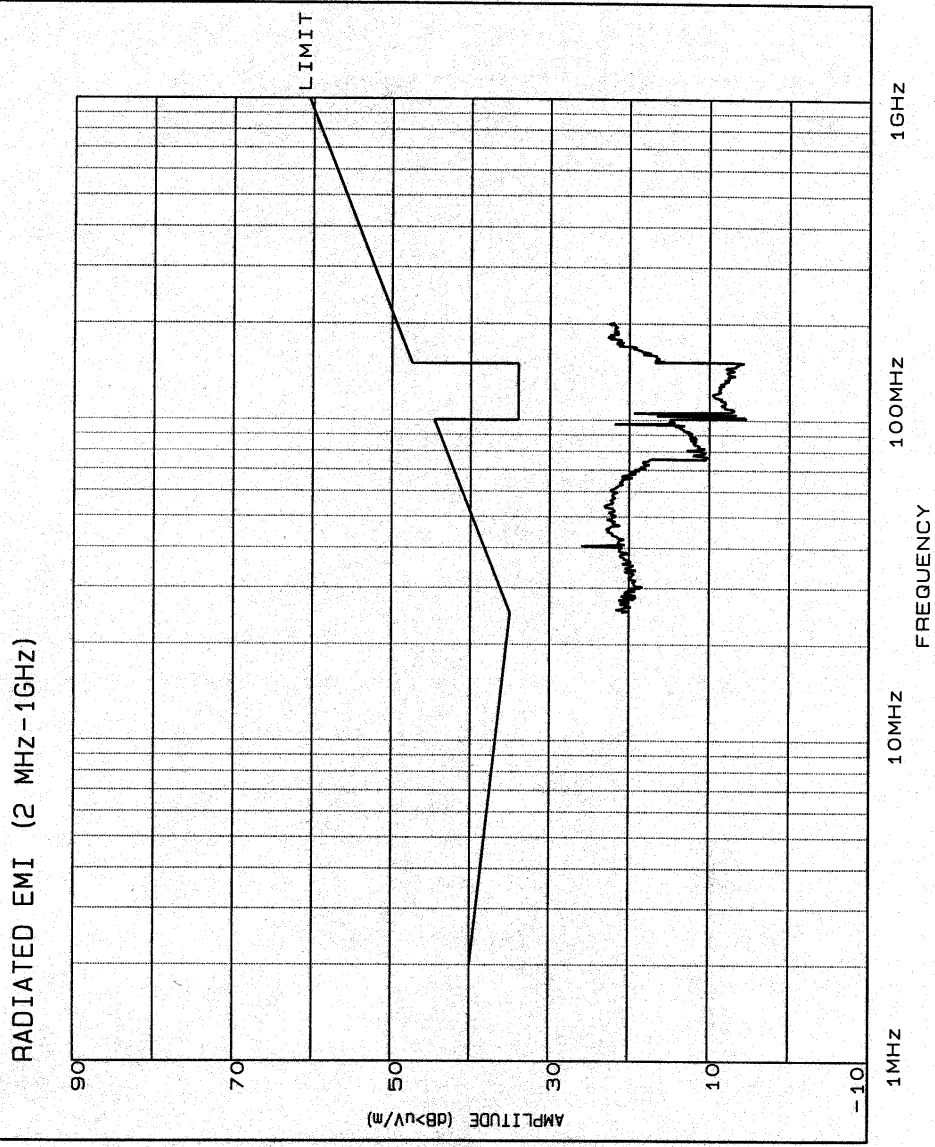

UNIT UNDER TEST

SRT-2000

TEST CONDITION or MODE

AMBIENT

PROCEDURE PARA. #

2.8.2

DATE

14 Jun 1999

TECHNICIAN

16654

SERIAL #

117045

ANTENNAS:

RVA 30 460-0118-546

EMCO 3104C 460-0119-436

VERTICAL

STODDART 029-0357-001

85668 85685A

PLOT #C99061417

ROOM #9

160D_RAD 08 OCT 1998

DO-160D CATEGORY M RADIATED EMISSIONS

UNIT UNDER TEST

SRT-2000

TEST CONDITION or MODE

AMBIENT

PROCEDURE PARA. #

2.8.2

DATE

14 Jun 1999

TECHNICIAN

16654

SERIAL #

117045

ANTENNAS:

EMCO 3104C 460-0119-436

HORIZONTAL

85668 85685A

PLOT #C99061418

ROOM #9

1600_RAD 08 OCT 1998

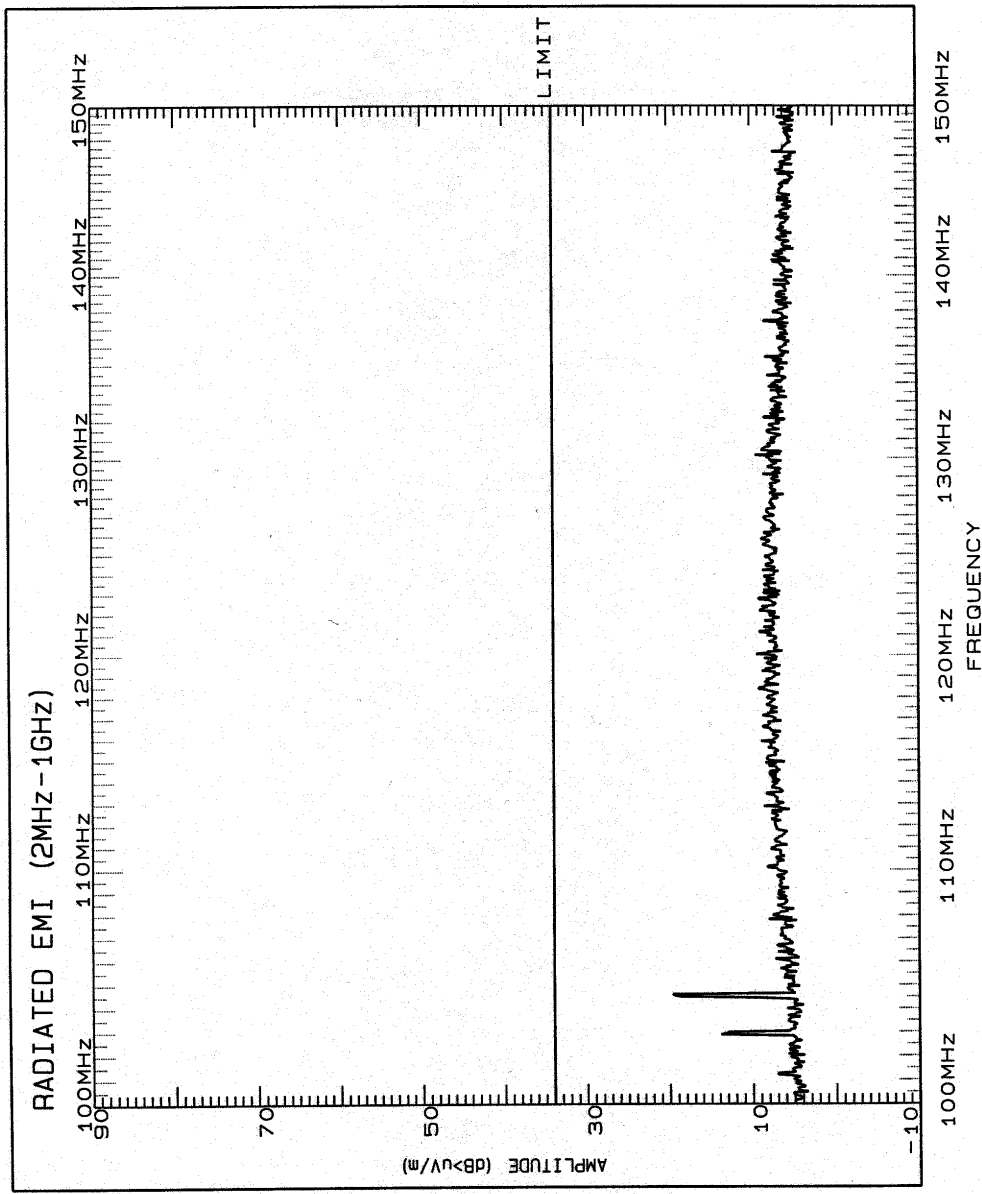

DO-160D CATEGORY M RADIATED EMISSIONS

UNIT UNDER TEST

SRT-2000

TEST CONDITION or MODE

AMBIENT

PROCEDURE PARA. #

2.8.2

DATE

14 Jun 1999

TECHNICIAN

16654

SERIAL #

117045

ANTENNAS:

EMCO 3104C 460-0119-436

VERTICAL

8566B 85665A

PLOT #C99061419

ROOM #9

160D_RAD 08 OCT 1998

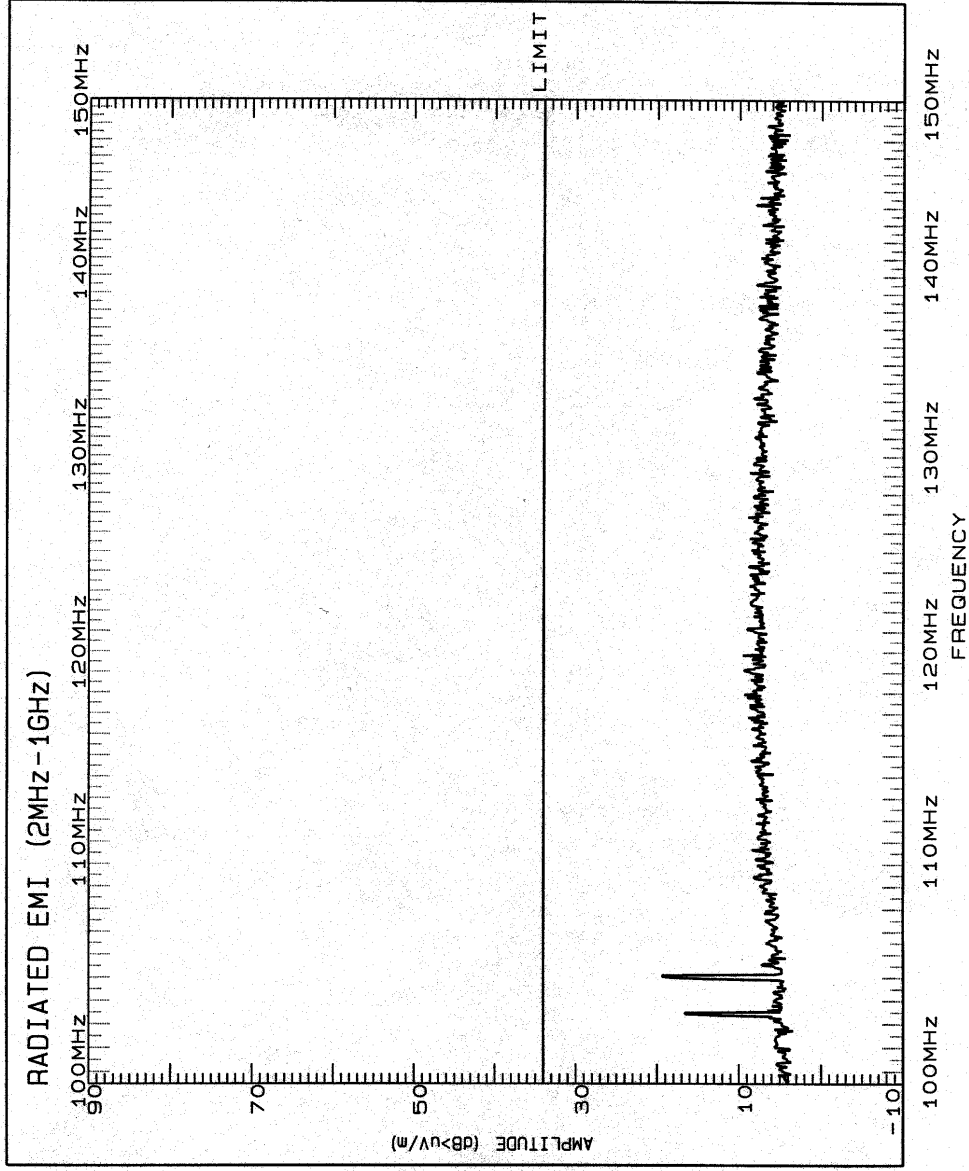

CATEGORY M RADIATED EMISSIONS

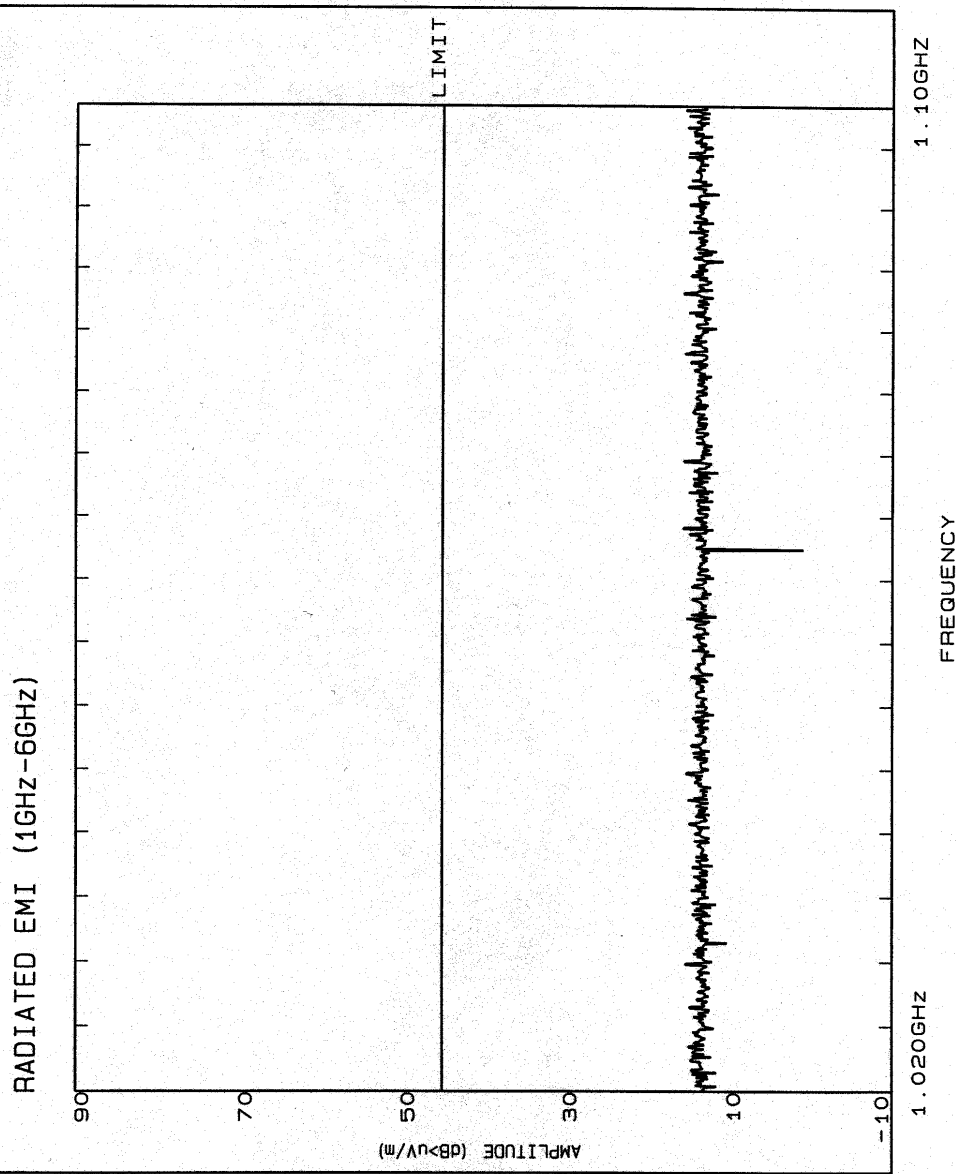

UNIT UNDER TEST

SRT-2000

TEST CONDITION or MODE

AMBIENT - *Horizontal*

PROCEDURE PARA. #

2.8.2

DATE

6/14/99

TECHNICIAN

16654

SERIAL #

117045

ANTENNAS:

EMCO 3115

SERIAL #2648

85685A

PLOT #C99061408

ROOM #9

160_GHZ 10 DEC 95

UNIT UNDER TEST

SRT-2000

TEST CONDITION or MODE

AMBIENT - *Horizontal*

PROCEDURE PARA. #

2.8.2

DATE

6/14/99

TECHNICIAN

16654

SERIAL #

117045

ANTENNAS:

EMCO 3115

SERIAL #2648

85685A

PLOT #C99061409

ROOM #9

160_GHZ 10 DEC 95

CATEGORY M RADIATED EMISSIONS

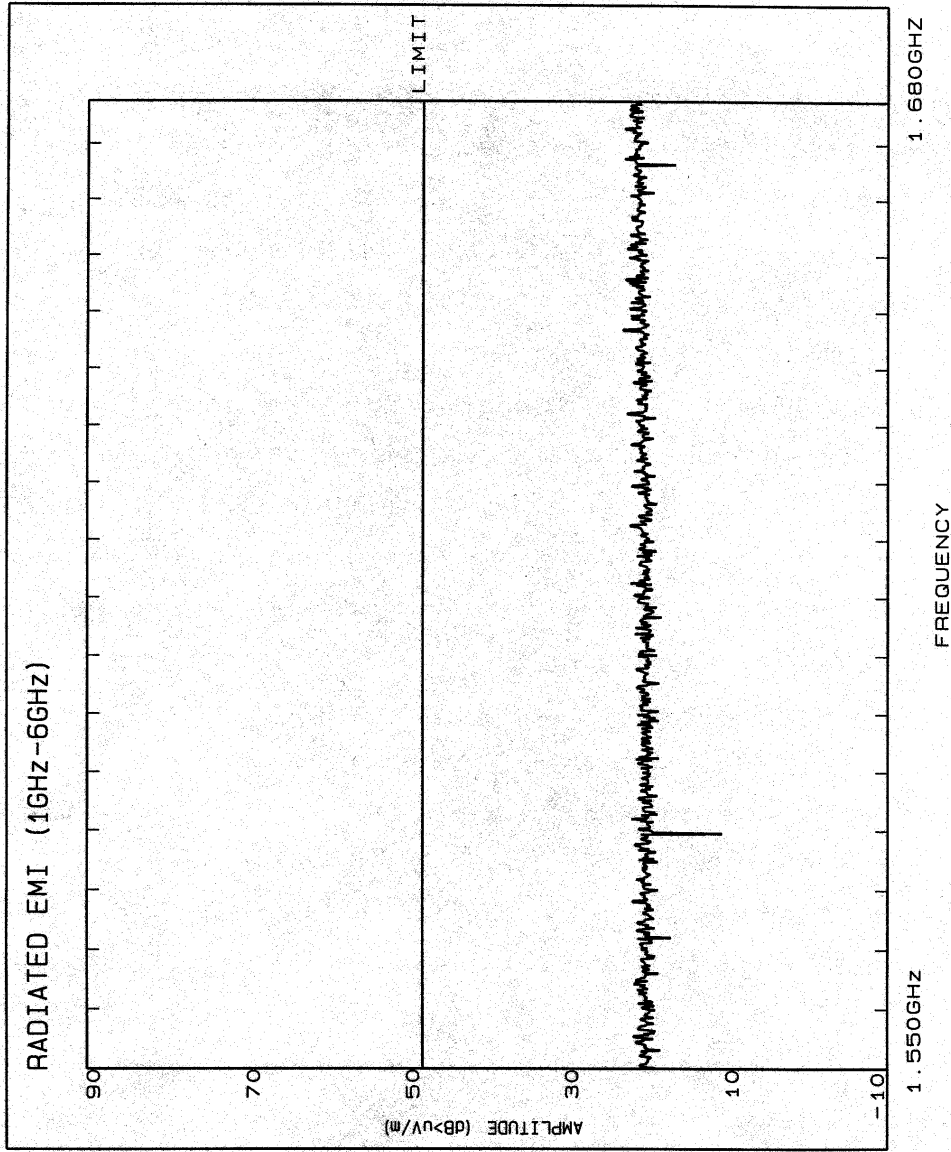

CATEGORY M RADIATED EMISSIONS

UNIT UNDER TEST

SRT-2000

TEST CONDITION or MODE

AMBIENT - *Horizontal*

PROCEDURE PARA. #

2.8.2

DATE

6/14/99

TECHNICIAN

16654

SERIAL #

117045

ANTENNA:

EMCO 3115

SERIAL #2648

PLOT #C99061410

ROOM #9

1600_GHZ 10 DEC 95

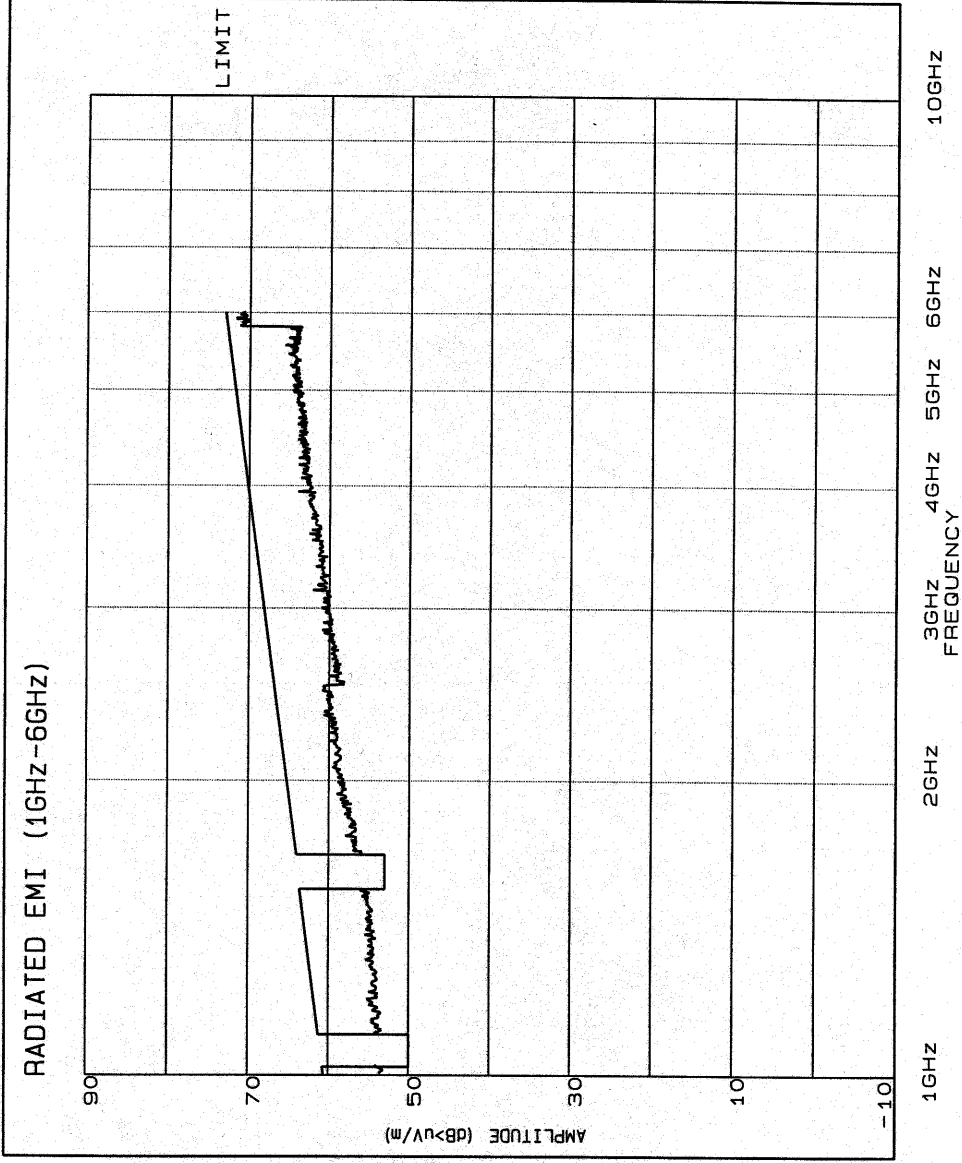

CATEGORY M RADIATED EMISSIONS

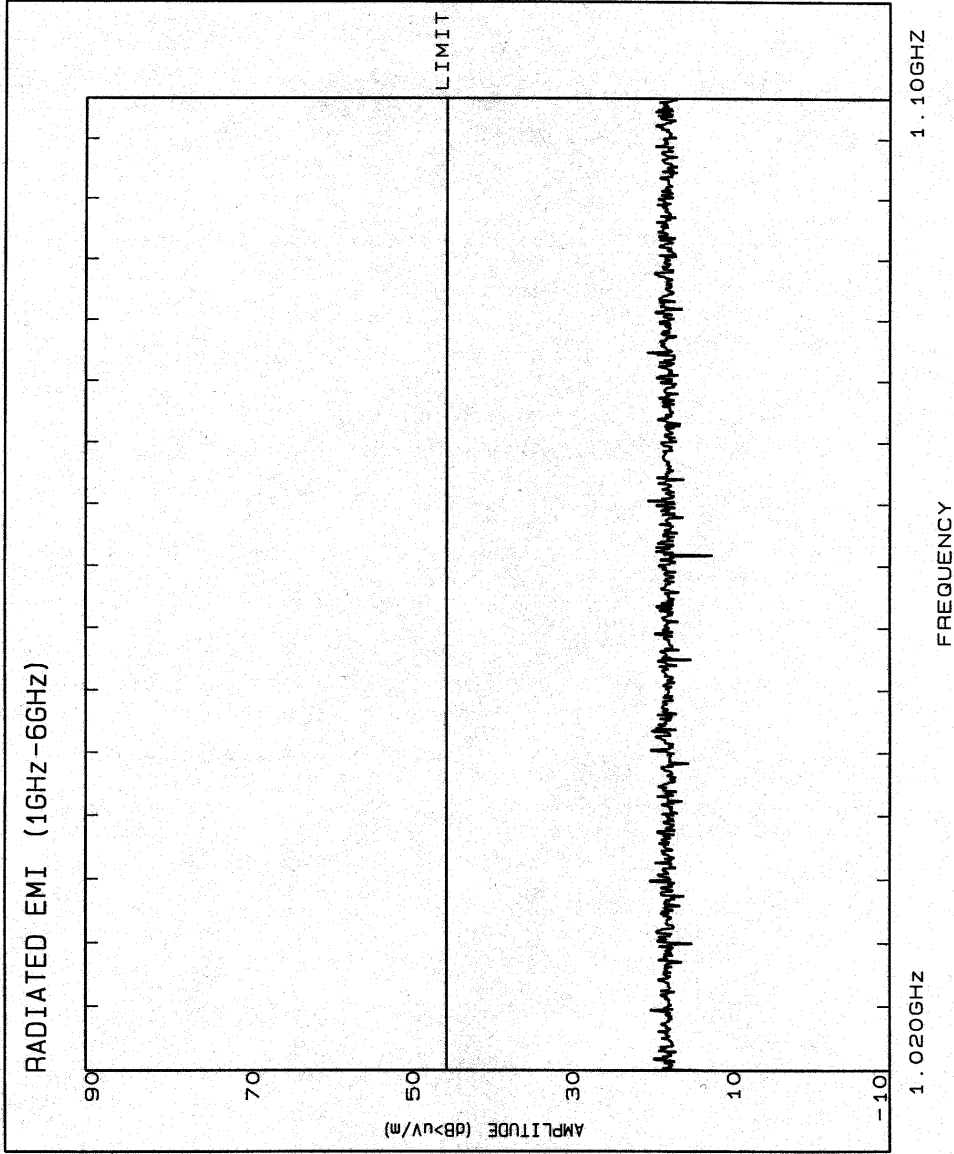

UNIT UNDER TEST

SRT-2000

TEST CONDITION or MODE

AMB VERT

PROCEDURE PARA. #

2.8.2

DATE

6/14/99

TECHNICIAN

16654

SERIAL #

117045

ANTENNAS:

EMCO 3115

SERIAL #2648

85685A

PLOT #C99061411

ROOM #9

160_GHZ 10 DEC 95

CATEGORY M RADIATED EMISSIONS

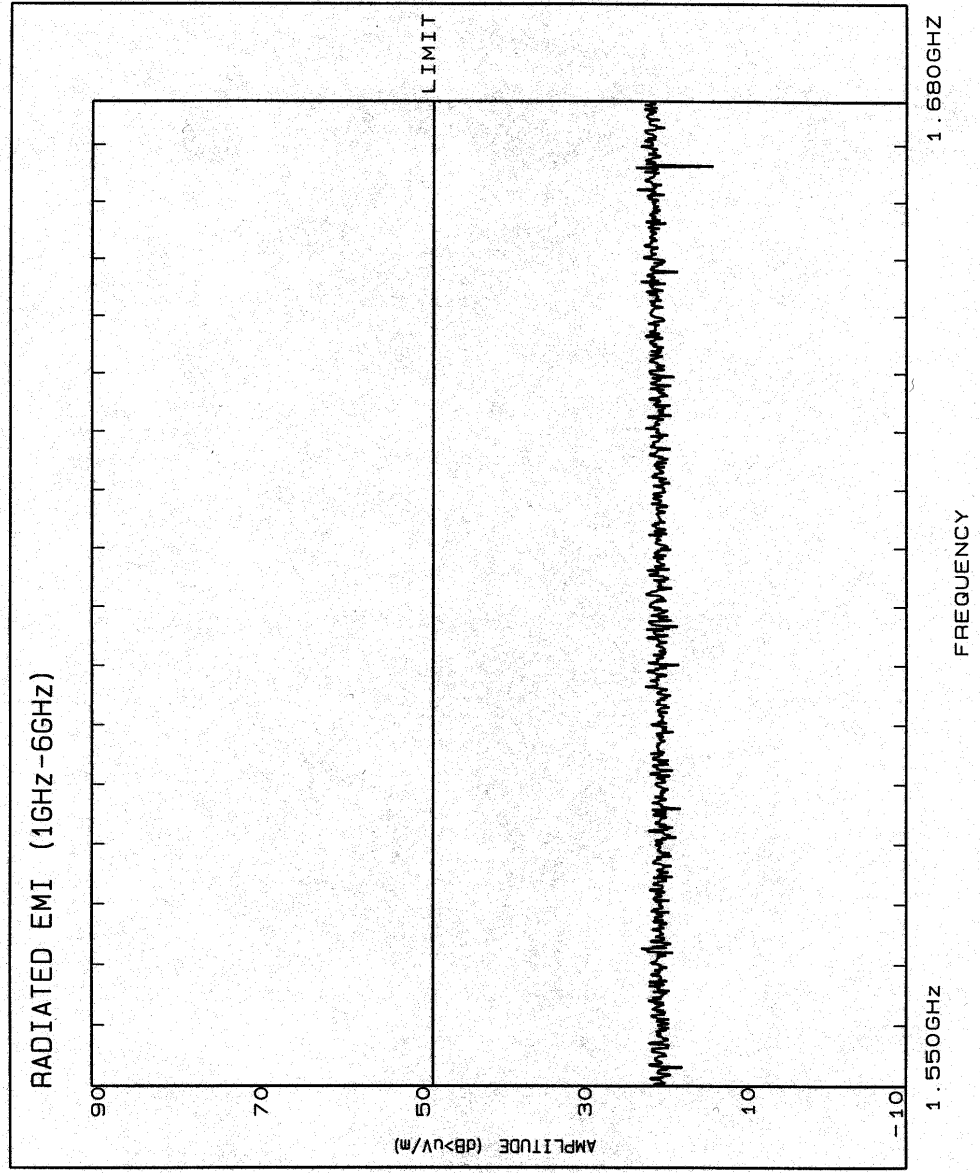

UNIT UNDER TEST

SRT-2000

TEST CONDITION or MODE

AMB VERT

PROCEDURE PARA. #

2.8.2

DATE

6/14/99

TECHNICIAN

16654

SERIAL #

117045

ANTENNAS:

EMCO 3115

SERIAL #2648

85685A

PLOT #C99061412

ROOM #9

160_GHZ 10 DEC 95

CATEGORY M RADIATED EMISSIONS

UNIT UNDER TEST

SRT-2000

TEST CONDITION or MODE

AMB VERT

PROCEDURE PARA. #

2.8.2

DATE

6/14/99

TECHNICIAN

16654

SERIAL #

117045

ANTENNA:

EMCO 3115

SERIAL #2648

PLOT #C99061413

ROOM #9

1600_GHZ 10 DEC 95

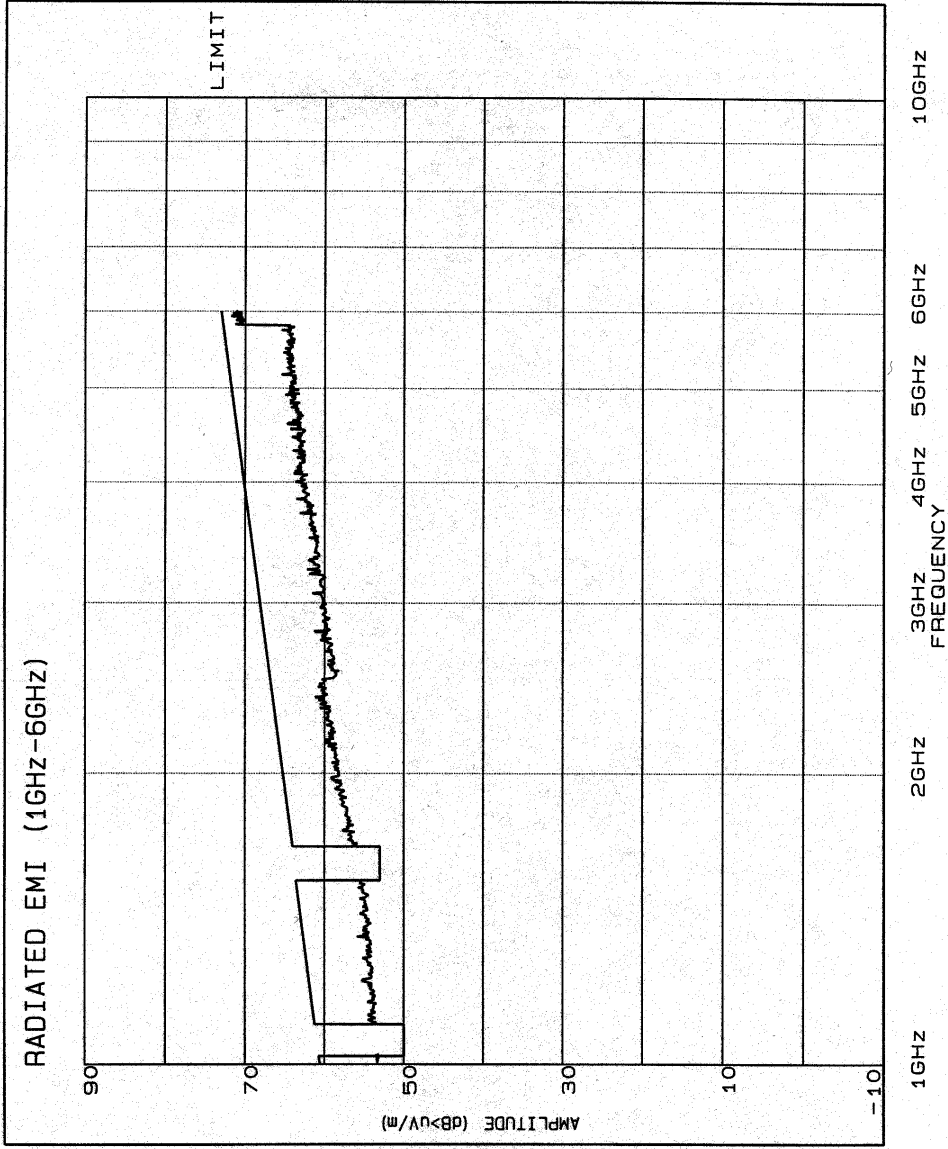

FCC RADIATED EMISSIONS

RADIATED EMI (1GHz-18GHz) NARROWBAND

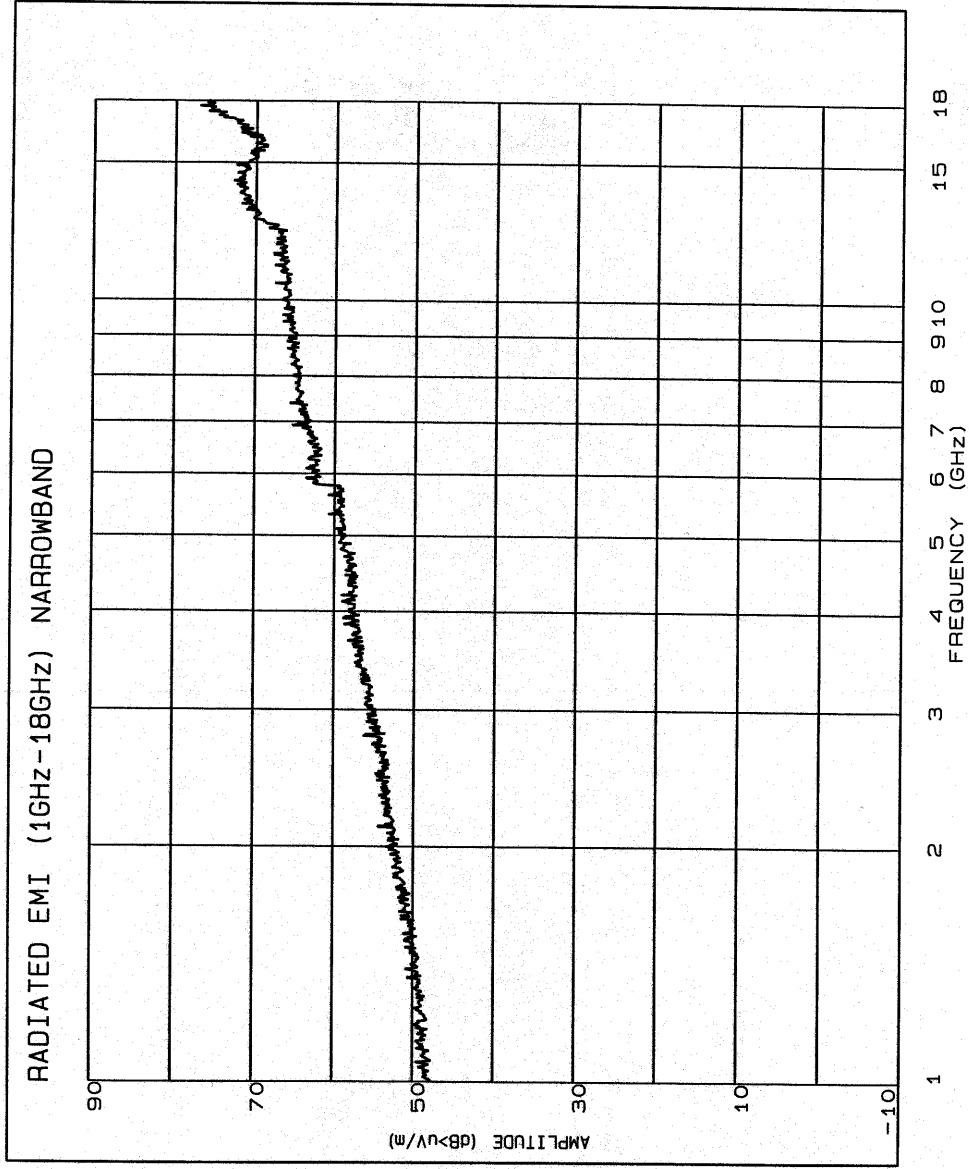

UNIT UNDER TEST

SRT-2000

TEST CONDITION or MODE

AMB VERT

PROCEDURE PARA. #

NA

DATE

6/14/99

TECHNICIAN

16654,

SERIAL #

117045

ANTENNA:

EMCO 3115

SERIAL #2648

PLOT #C99061414

ROOM #9

FCC_RE 18 APR 93

FCC RADIATED EMISSIONS

RADIATED EMI (1GHz-18GHz) NARROWBAND

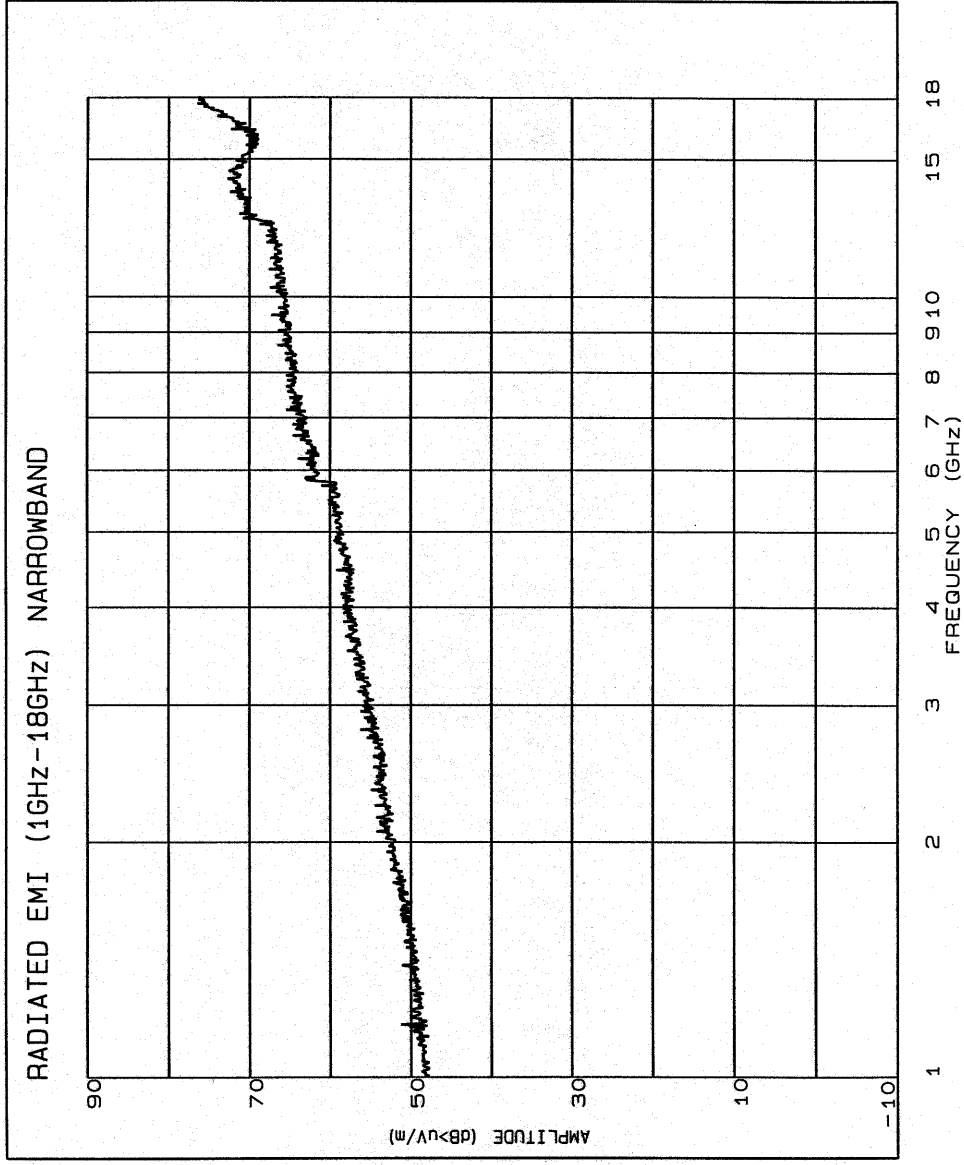

UNIT UNDER TEST

SRT-2000

TEST CONDITION or MODE

AMB HOR

PROCEDURE PARA. #

NA

DATE

6/14/99

TECHNICIAN

16654.

SERIAL #

117045

ANTENNA:

EMCO 3115

SERIAL #2648

PLOT #C99061415

ROOM #9

FCC_RE 18 APR 93

CATEGORY M RADIATED EMISSIONS

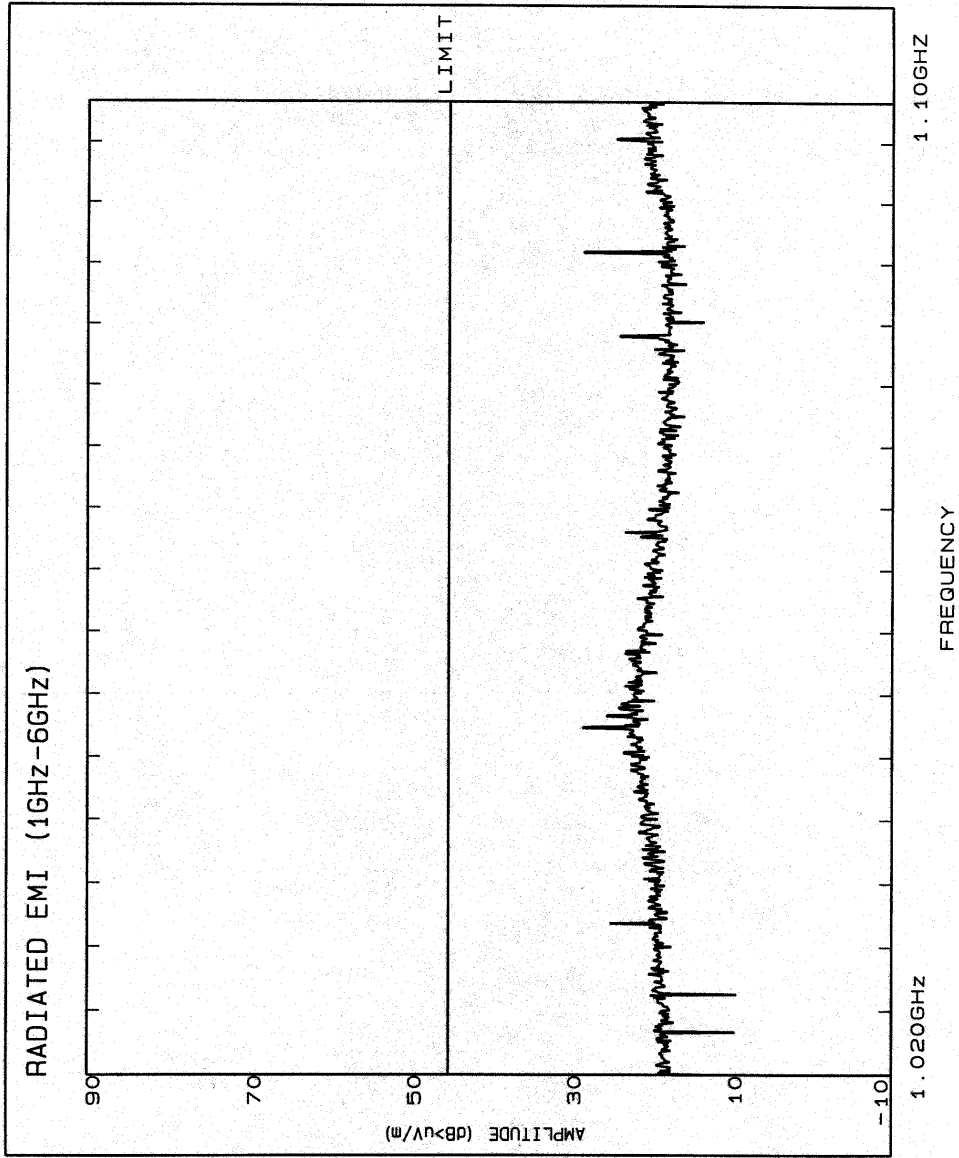

UNIT UNDER TEST

SRT-2000

TEST CONDITION or MODE

ON VERT

PROCEDURE PARA. #

2.8.2

DATE

6/14/99

TECHNICIAN

16654

SERIAL #

117045

ANTENNAS:

EMCO 3115

SERIAL #2648

85685A

PLOT #C99061402

ROOM #9

160_GHZ 10 DEC 95

CATEGORY M RADIATED EMISSIONS

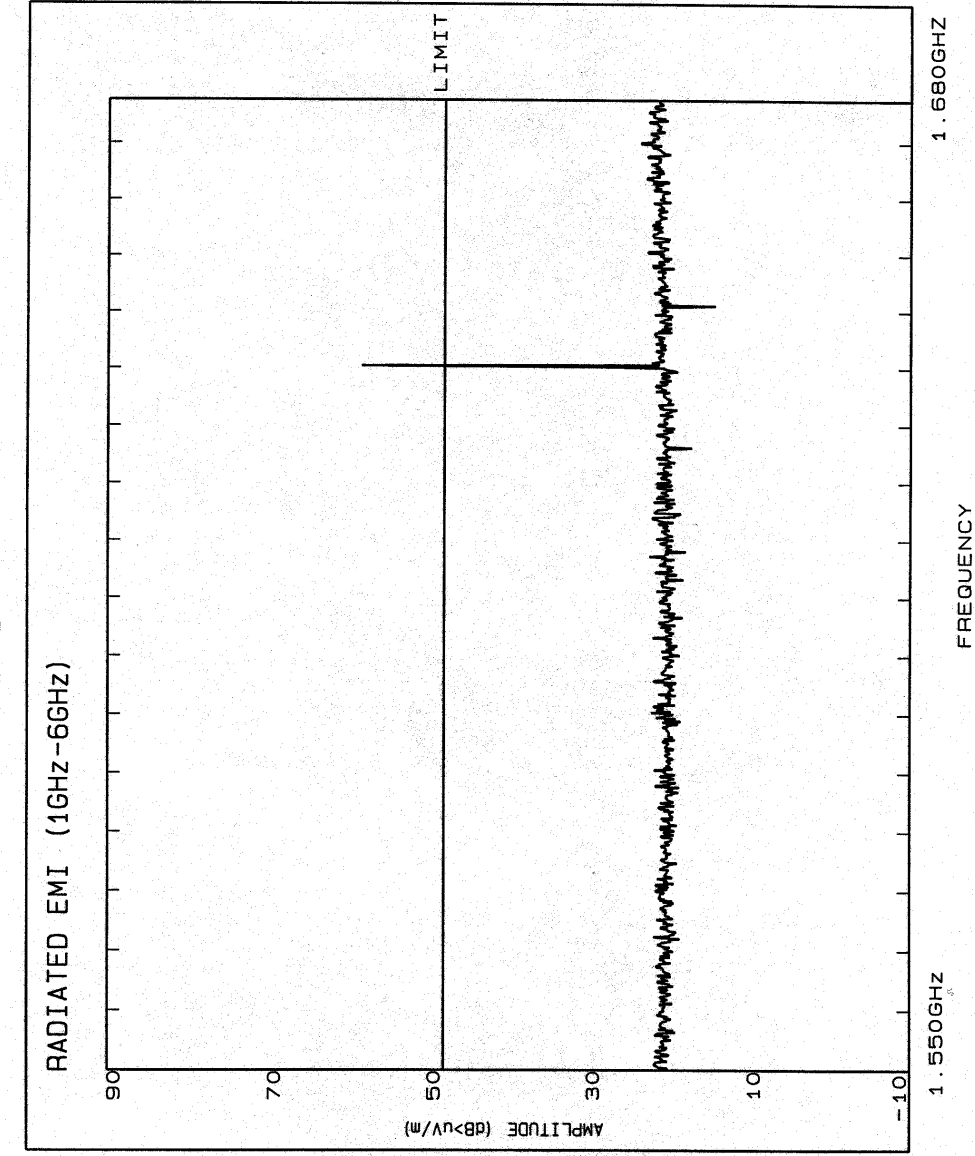

UNIT UNDER TEST

SRT-2000

TEST CONDITION or MODE

ON VERT

PROCEDURE PARA. #

2.8.2

DATE

6/14/99

TECHNICIAN

16654

SERIAL #

117045

ANTENNAS:

EMCO 3115

SERIAL #2648

85685A

PLOT #C99061403

ROOM #9

160_GHZ 10 DEC 95

CATEGORY M RADIATED EMISSIONS

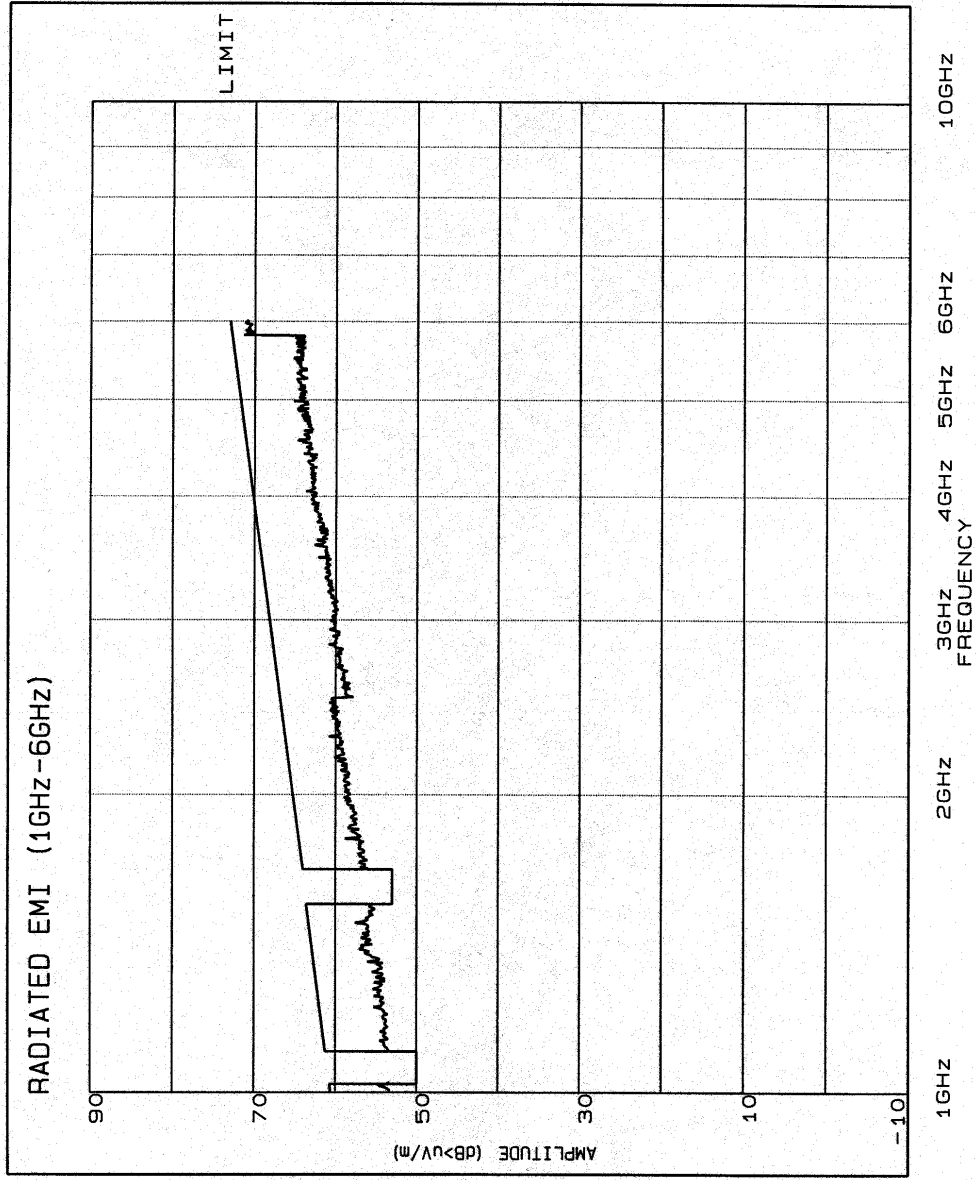

UNIT UNDER TEST

SRT-2000

TEST CONDITION or MODE

ON VERT

PROCEDURE PARA. #

2.8.2

DATE

6/14/99

TECHNICIAN

16654.

SERIAL #

117045

ANTENNA:

EMCO 3115

SERIAL #2648

PLOT #C99061404

ROOM #9

1600_GHZ 10 DEC 95

9.9 Frequency Stability

9.9.1 FCC Requirements

The discussion and test results in this section address and meet the requirements of the following FCC requirements:

Section 2.1055 (a) (2), (b), (d) (1) (3)

(a) (2) The frequency stability shall be measured with variation of ambient temperature from -20° to $+50^{\circ}$ centigrade for equipment licensed for use aboard aircraft in the Aviation Services under part 87 of FCC Code of Federal Regulations Title 47.

(b) The frequency measurements shall be made at the extremes and at intervals of not more than 10° centigrade through the range. A period of time sufficient to stabilize all of the components of the oscillator circuit at each temperature level shall be allowed prior to frequency measurement. The short term transient effects on the frequency of the transmitter due to keying shall be shown.

(d) (1) (3) The frequency stability shall be measured with variation of primary supply voltage of 85 to 115 percent of the nominal value. The supply voltage shall be measured at the input to the cable normally provided with the equipment, or at the power supply terminals if cables are not normally provided.

Section 87.133

The carrier frequency of each station must be maintained within these tolerances:

Frequency band (lower limit exclusive, upper limit inclusive), and categories of stations	Tolerance
Band – 470 to 2450 MHz Aircraft Earth Station	320 Hz ¹

¹ For purposes of certification, a tolerance of 160 Hz applies to the reference oscillator of the AES transmitter. This is a bench test.

9.9.2 Test Procedures and Results

Test Equipment

Quantity	Item	Description
1	HP8566B1	Spectrum analyzer
1	Test pallet with IP & EM monitoring functions	
1	30 dB pad, 25 Watt pad	
1	20 dB pad	
1	10 MHz high stability reference (stability > 19.2 PPB)	
1	Temperature chamber	
1	400 Hz Variable Transformer	

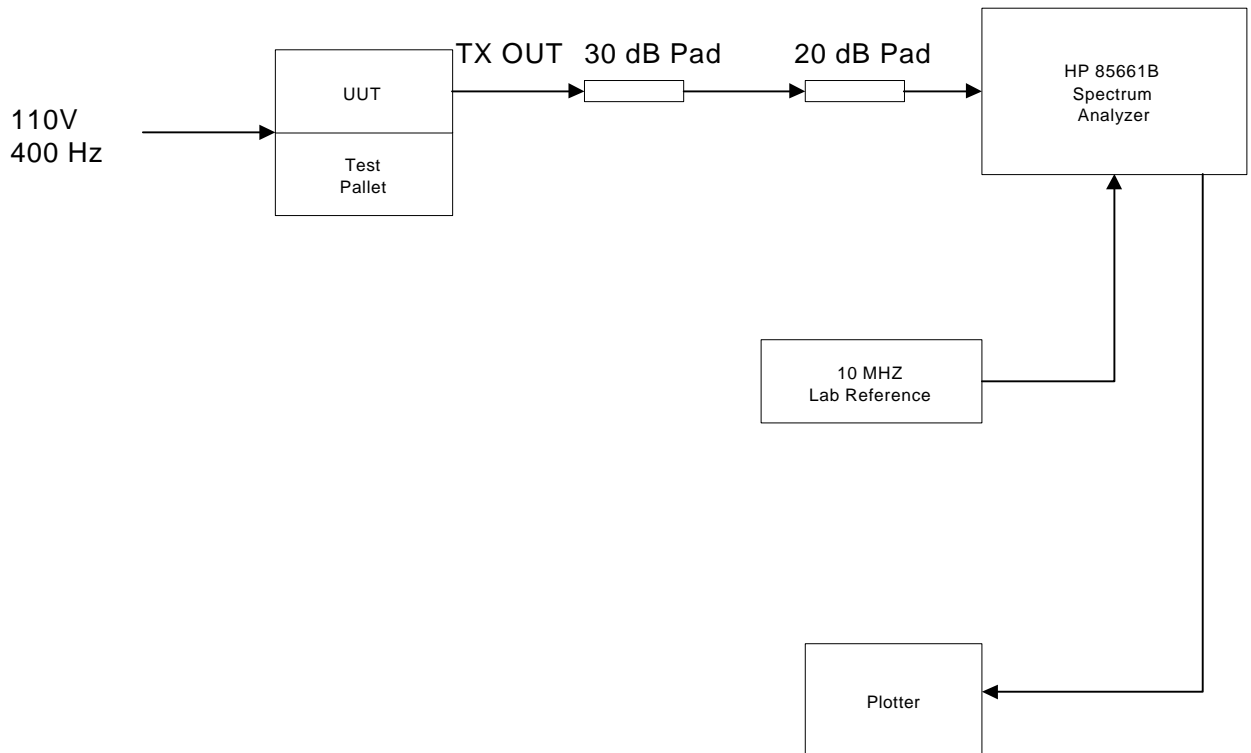

Figure 9.9.2 Frequency Stability Setup

Frequency Drift vs. Temperature (FCC)

1. Place UUT and mount in temperature chamber. Connect UUT and test equipment as shown in Figure 1. Place the UUT in maintenance mode.
2. Bring up an unmodulated carrier from the UUT at 1660.5 MHz. Set the channel module attenuator to 14 dB. Adjust to the RFU attenuator so that the HPA out put power level is at least 2 Watts.
3. Adjust the spectrum analyzer as follows: center frequency = 1660.5 MHz, span = 1 kHz, resolution bandwidth = 10 Hz, video bandwidth = 30 Hz.
4. Bring ambient temperature of UUT up to 50 degrees C. Allow temperature of unit to stabilize.
5. Place marker of spectrum analyzer on peak, plot data and record data on data sheet.
6. Reduce ambient temperature of UUT by 10 degrees C. Allow temperature of unit to stabilize.
7. Place marker of spectrum analyzer on peak, plot data and record data on data sheet.
8. Repeat Steps 6 and 7 until data for –20 degrees C is taken.

FCC Frequency Stability Data – AC Power

UUT Type SRT-2000

UUT S/N E5

Engineer G. M. Reyes

Date 3/19/99

Temperature and Voltage Variation

Carrier Frequency 1660.500000 MHz

Low voltage (L): 85 x 115 VAC = 97.8 VAC, 400 Hz

Nominal Voltage (N): 1x115 VAC, 400 Hz

High Voltage (H): 1.15 x 115 VAC = 132.3 VAC, 400 Hz

Temp (°C)	Voltage (AC, 400Hz)	Measured Frequency (Hz)	Expected Carrier - Measured Carrier (Hz)	Pass/Fail
+50	L	1660500037	37	P
	N	1660500037	37	P
	H	1660500037	37	P
+40	L	1660500037	37	P
	N	1660500038	38	P
	H	1660500039	39	P
+30	L	1660500040	40	P
	N	1660500039	39	P
	H	1660500040	40	P
+20	L	1660500038	38	P
	N	1660500038	38	P
	H	1660500038	38	P
+10	L	1660500039	39	P
	N	1660500039	39	P
	H	1660500038	38	P
0	L	1660500043	43	P
	N	1660500044	44	P
	H	1660500043	43	P
-10	L	1660500048	48	P
	N	1660500048	48	P
	H	1660500048	48	P
-20	L	1660500040	40	P
	N	1660500038	38	P
	H	1660500039	39	P

UUT passes if the frequency deviation between expected carrier and measured carrier is within $\pm 320\text{Hz}$.

FCC Frequency Stability Data – DC Power

UUT Type SRT-2000

UUT S/N E5

Engineer G. M. Reyes

Date 3/29/99

Temperature and Voltage Variation

Carrier Frequency 1660.500000 MHz

Low voltage .85 x 28 VDC = 23.8 VDC

Nominal Voltage = 28 VDC

High Voltage = 1.15 x 28 VDC = 32.2 VDC

Temp (°C)	Input DC Voltage	Measured Frequency (Hz)	Expected Carrier - Measured Carrier (Hz)	Pass/Fail
+50	L	1660500016	16	P
	N	1660500021	21	P
	H	1660500016	16	P
+40	L	1660500017	17	P
	N	1660500017	17	P
	H	1660500016	16	P
+30	L	1660500015	15	P
	N	1660500015	15	P
	H	1660500014	14	P
+20	L	1660500014	14	P
	N	1660500014	14	P
	H	1660500014	14	P
+10	L	1660500012	12	P
	N	1660500012	12	P
	H	1660500012	12	P
0	L	1660500016	16	P
	N	1660500016	16	P
	H	1660500016	16	P
-10	L	1660500021	21	P
	N	1660500021	21	P
	H	1660500021	21	P
-20	L	1660500014	14	P
	N	1660500015	15	P
	H	1660500015	15	P

UUT passes if the frequency deviation between expected carrier and measured carrier is within $\pm 320\text{Hz}$.

ADDITIONAL TEST

9.10 Frequency Spectrum

9.10.1 FCC Requirements

The discussion and test results shown in this section address and meet the requirements of the following FCC requirements:

Section 2.1057 (a) (1)

In all of the measurements set forth in Section 2.1051 and 2.1053 the spectrum shall be investigated from the lowest radio frequency signal generated in the equipment, without going below 9 kHz, up to:

At least the tenth harmonic of the highest fundamental frequency or to 40 GHz, whichever is lower (if the equipment operates below 10 GHz).

Section 87.139

Transmitters used in the Aircraft Earth Stations must employ BPSK for transmission rates up to and including 2400 bits per second, and QPSK for higher rates.

9.10.2 Test Procedures

Per Carrier Transmit Spectrum

1. Connect a HP 8566 spectrum analyzer to the SRT Transmit output monitoring port as shown in Figure 9.10.2. Using IP-906 501 block file, request a frequency in the middle of the transmit band (1643.5 MHz).
2. Perform the following for each channel rate/modulation type :
3. Set the spectrum analyzer span and resolution bandwidth as given below.

			Plot 1		Plot 2	
			Spectrum Analyzer		Spectrum Analyzer	
Bit Rate	Mod Type	Symbol Rate	Span	Res BW	Span	Res BW
600	A-BPSK	600	6.0 kHz	30 Hz	70 kHz	300 Hz
1200	A-BPSK	1200	12.0 kHz	100 Hz	70 kHz	300 Hz
10500	Q-BPSK	5250	52.5 kHz	150 Hz	-	-
8400	Q-BPSK	5600	56.0 kHz	150 Hz	-	-
21000	Q-BPSK	10500	105.0 kHz	300 Hz	-	-

4. Using IP-906, set the SRT-2000 to transmit an un-modulated continuous carrier at 25 Watts output.
5. On the spectrum analyzer tuned to the carrier frequency do a peak search, marked to center frequency, marker to reference level.
6. The carrier should now be centered and the carrier peak adjusted to the reference level.
7. Using IP-906, set the SRT-2000 to transmit a continuous signal at the "channel rates/modulation types" given in the above table.
8. Average the output spectrum for at least 20 sweeps.
9. Set display such that only the averaged spectrum appears.
10. Plot spectrum and label with symbol rate.
11. For symbol rates of 600 and 1200 repeat with spectrum analyzer set to 70 kHz span and 300 Hz resolution bandwidth. Average the output at least 20 sweeps.
12. Set display such that only the averaged spectrum appears.
13. Plot and label with symbol rate.
14. Indicate Pass or Fail on the data sheet.
15. Repeat Steps 2 to 13

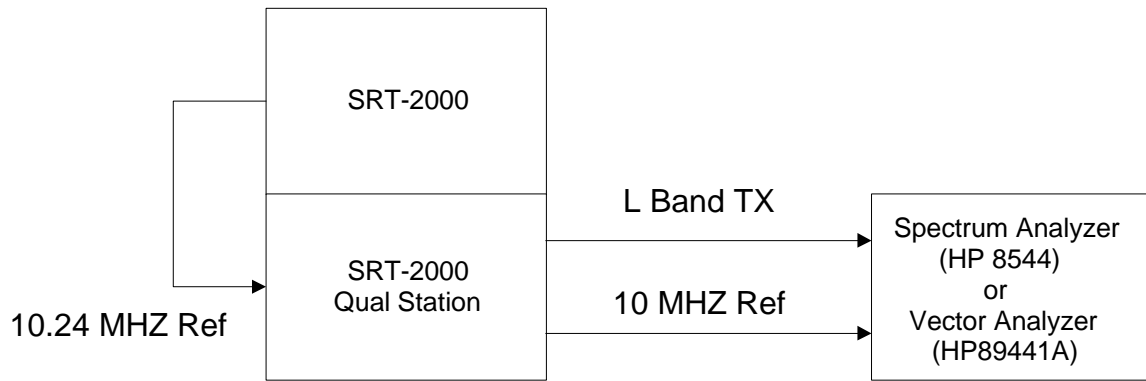

Figure 9.10.2 Test Setup

Test Results

For additional spectral data, please refer to the spectrum analyzer data in sections 9.7 and 9.8.

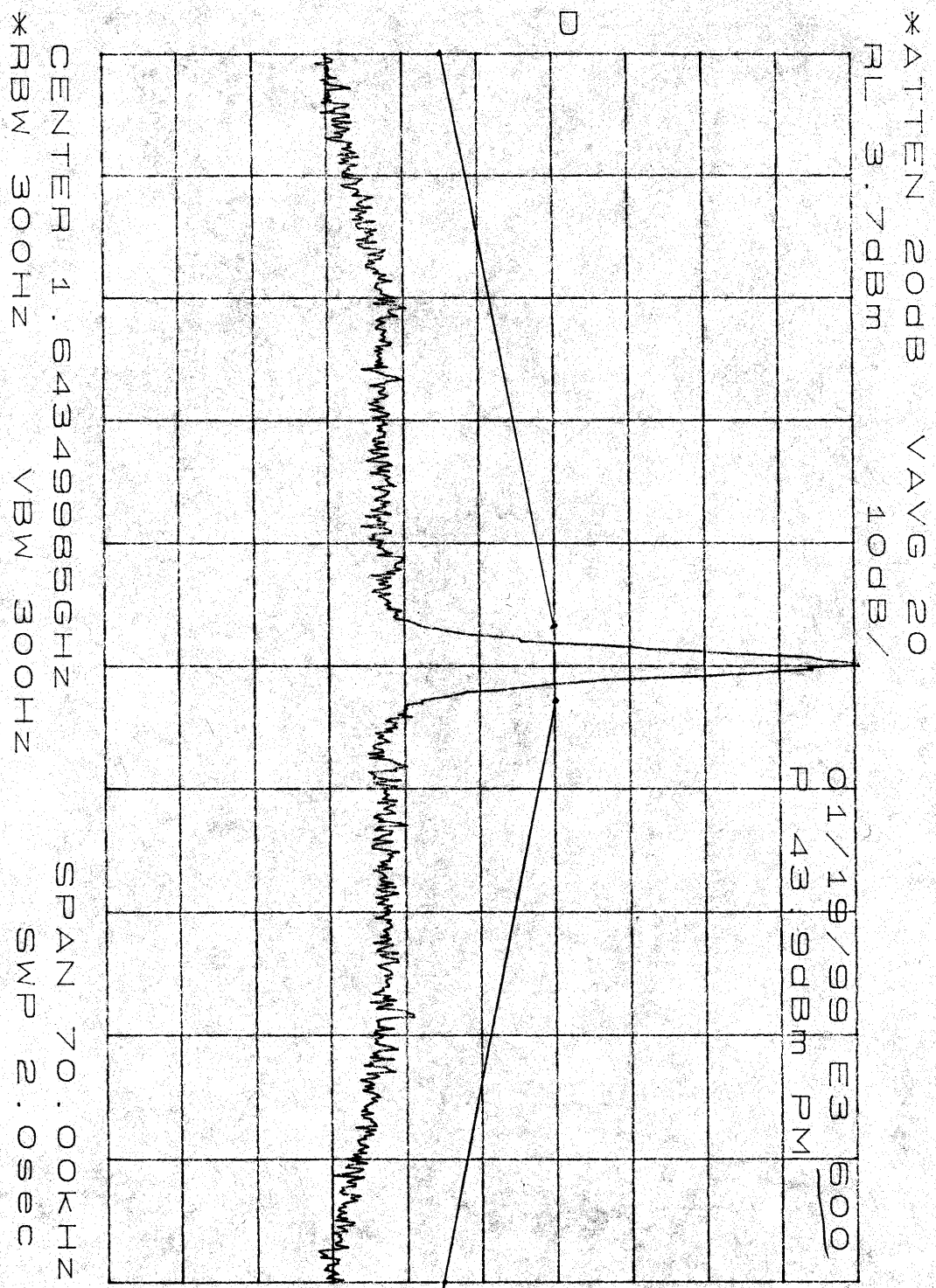

Figure 9.10.1 Frequency Spectrum – 600 BPS, 70 kHz Span

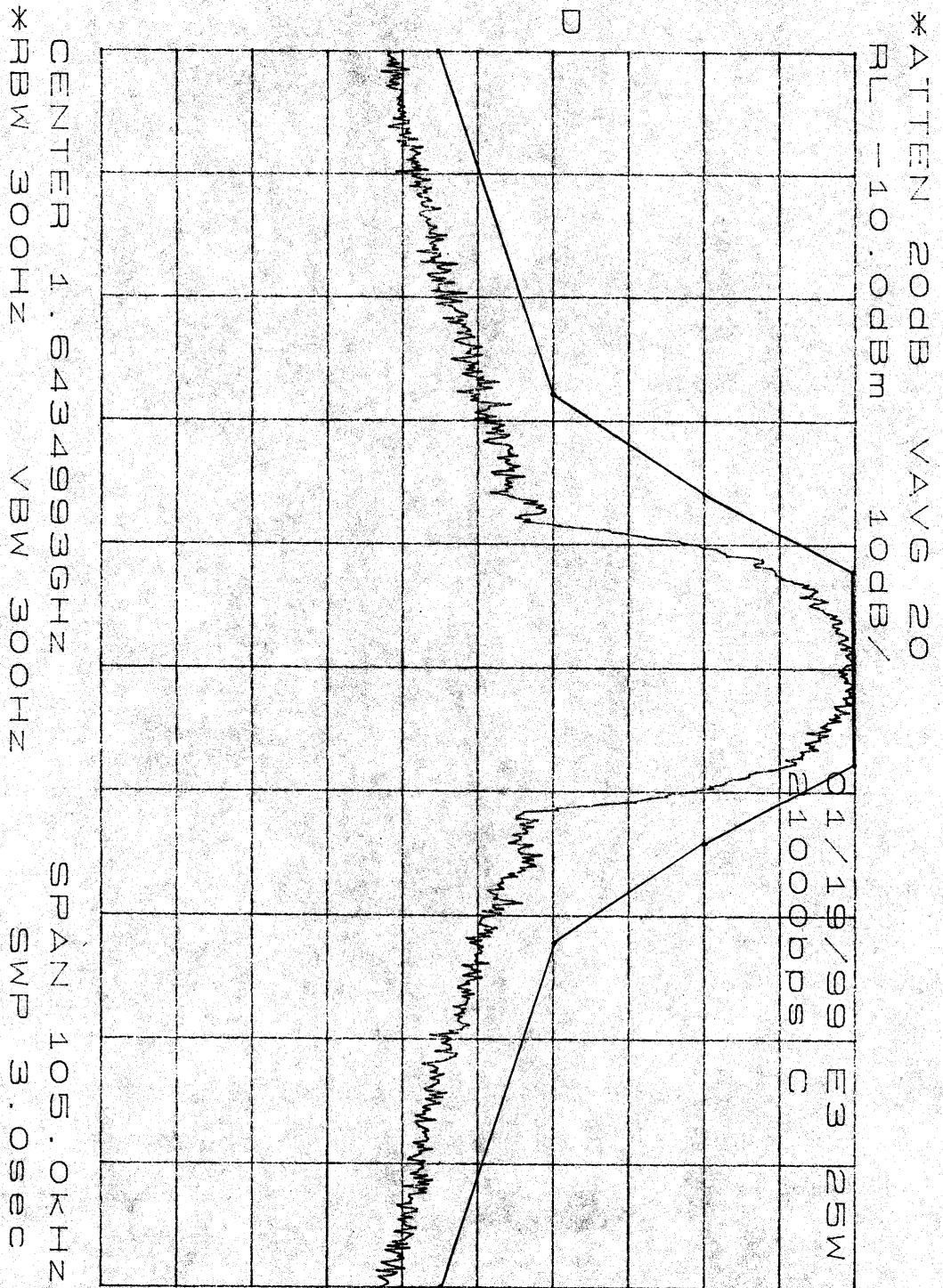

Figure 9.10.2 Frequency Spectrum – 21000 BPS, 105 kHz Span

ADDITIONAL TEST

9.11 Priority and Preemption

The SRT-2000 AES dedicates one of its available channels to a continuous data link capability with the GES to which it is logged on. This data channel continuously monitors the GES P channel signal, and transmits R or T channel messages to the GES. Transmission is based on need to respond to GES requests, to request channel assignments (as may be required to place air to ground calls) or to transmit data from the onboard data link sources. GES to AES call requests are made on the P channel - providing information such as C channel frequency selection and the priority of the call. AES to GES calls are initiated by the AES on the R channel - providing call priority and destination information. In return, when accepted by GES, AES is provided a C channel frequency assignment.

The priority, which is assigned to each call, as it originates, provides the basis for handling of the call within the AES and GES. These priorities are established and the requirements for their use are defined in Inmarsat System Definition Manual. Inmarsat also specifies a number of protocol tests, which must be completed to verify that the AES complies with the priority and preemption requirements.

For AES to GES calls, the pilot specifies the nature (priority) of the call as a part of the call set up procedure. If the AES resources are exhausted, the pilot is prompted to select whether to preempt a lower priority call (cabin call), or have the call queued until resources are available. This operation is in "real time" in the sense that the pilot makes the decision at the time that the call is placed. If he elects to queue the call, he can later use the preempt feature if the situation warrants. Selection of the preemption feature will terminate one of cabin calls which is in progress and will make that channel resource available for the call.

For GES to AES calls, the pilot involvement is not practical. As an upcoming call request is made to the AES, the SRT-2000 system processor examines the status of the channel modules to determine if any channel is available for assignment. The processor also examines the status of the cockpit lines to determine their availability. If the incoming call priority is "Cockpit Safety" or greater and a cockpit line is available and all channel modules are in use, one of the cabin calls will be terminated and that channel module resource will be used to complete the call. If the cockpit line(s) are busy and the incoming call is of greater priority than one of calls currently placed, that call will be terminated and the resources used for the incoming call. In the event that call has the same or lower priority than the cockpit calls already placed, it will be rejected by the AES.

9.11.1 FCC Requirements

The discussion and test results shown in this section address and meet the requirements of the following FCC requirements:

Section 87.187 (q)

In the frequency bands 1549.500-1558.500 MHz and 1651.000-1660.000 MHz, the Aeronautical Mobile-Satellite requirements that cannot be accommodated in the distress and safety frequency bands 91554.0-1545.0 MHz) and 1645-1646.5 MHz) shall have priority access with real-time preemptive capability for communications in the Mobile-Satellite Service.

Section 87.189 (e)

Transmission of public correspondence must be suspended when such operation will delay or interfere with message pertaining to safety of life and property or regularity of flight, or when ordered by the captain of the aircraft.

9.11.2 Test Procedures

- (A) To verify the ability of the AES to preempt a cabin call with a higher priority cockpit call when sufficient resources are not available.
- (B) To verify the ability of the GES to preempt a cabin call with a higher priority cockpit call when sufficient resources are not available.

This test is performed at ambient temperature.

9.11.3 Test Equipment List

Quantity	Item
1	SRT-2000
1	CIU-906
1	MCDU
1	Over the air test station or equivalent
1 - 5*	Cabin telephones
1 - 5*	Ground telephones
1	Logging Trace PC

*Dependent on how many channel modules are installed in the SRT-2000. See test procedure.

9.11.4 Test Procedures Air-to-Ground

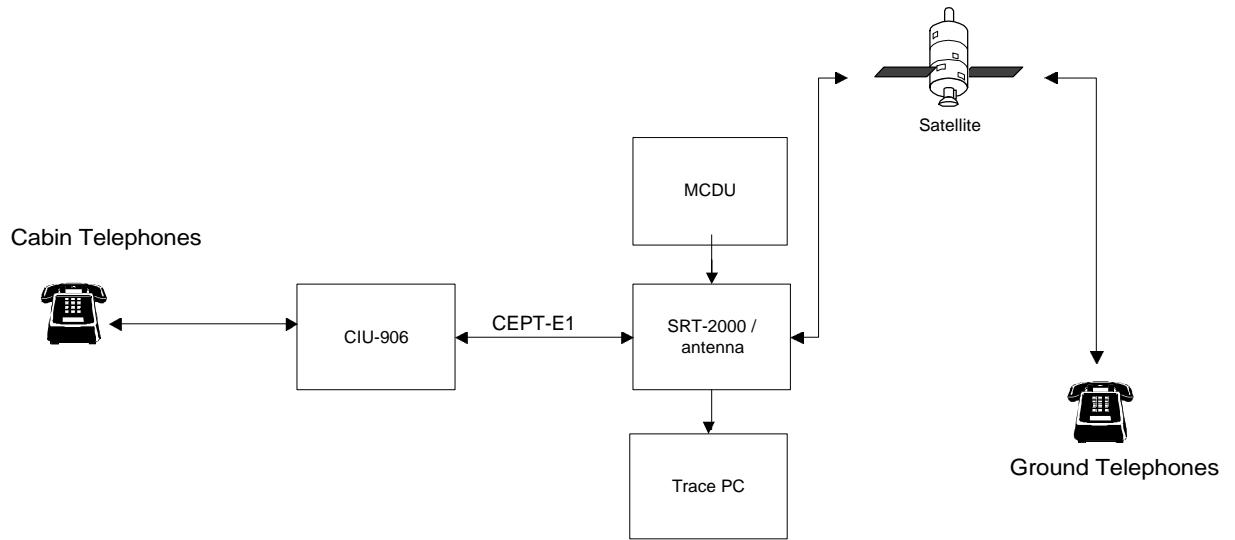

Figure 9.11.4 Priority and Preemption Setup

1. Setup the equipment as shown in Figure 9.11.4.
2. Make sure that cabin calls are enabled on the AES.
3. Allow the SRT to log-on to the GES.
4. Set the priority 4 to/from cockpit discrete to zero, to prevent APC calls from being placed to or from the cockpit interface.
5. Place N number of telephone calls from the cabin to exhaust all available channel modules in the SRT-2000 ($N = \#$ of channel modules installed minus one).
6. Place a priority 3 cockpit air-to-ground call on the MCDU.
7. Press ***Preempt** on the MCDU for the cockpit call.
8. Observe that a cabin call is disconnected, and the cockpit call placed in real time.
9. Record result on data sheet.

9.11.5 Test Procedures Ground-to-Air

1. Setup the equipment as shown in Figure 9.11.4.
2. Make sure that cabin calls are enabled on the AES.
3. Set the priority 4 to/from cockpit discrete to zero, to prevent APC calls from being placed to or from the cockpit interface.
4. Allow the SRT to log-on to the GES.
5. Place N number of telephone calls from ground phones to cabin phones to exhaust all available channel modules in the SRT-2000 (N = # of channel modules installed minus one). Use terminal ids to route the calls to the cabin.
6. Place a priority 3 call from another ground telephone to the AES with a pre-determined number to the cockpit.
7. Verify that a cabin call is disconnected and the call in step 5. is routed to the cockpit.
8. Record result on data sheet.

9.11.6 Test Results

Air-to-Ground Preemption Demonstrated (Pass/Fail) <PASS>

Ground-to-Air Preemption Demonstrated (Pass/Fail) <PASS>