

REVISION HISTORY

IND.	DATE	DESCRIPTION	PREP	APPROVED	A.Q.
A	11/10/16	EC 4999	G.BERNI	J.GALIERE	D.BONNEFILLE
B	20/07/17	EC 5054	RESSIGEAC	LAFFONT	JEAN-JEAN

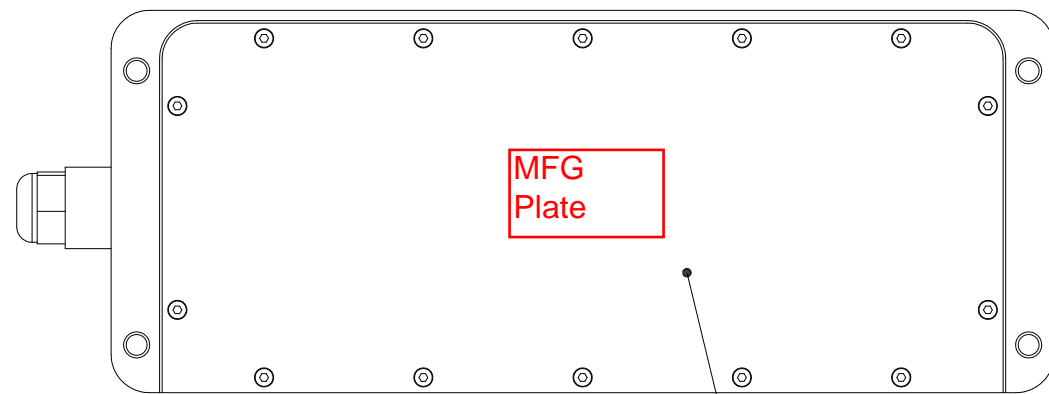

MH1 1
MH18 14

SEE NOTE

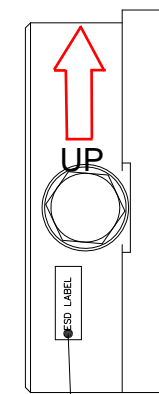

MH22 1

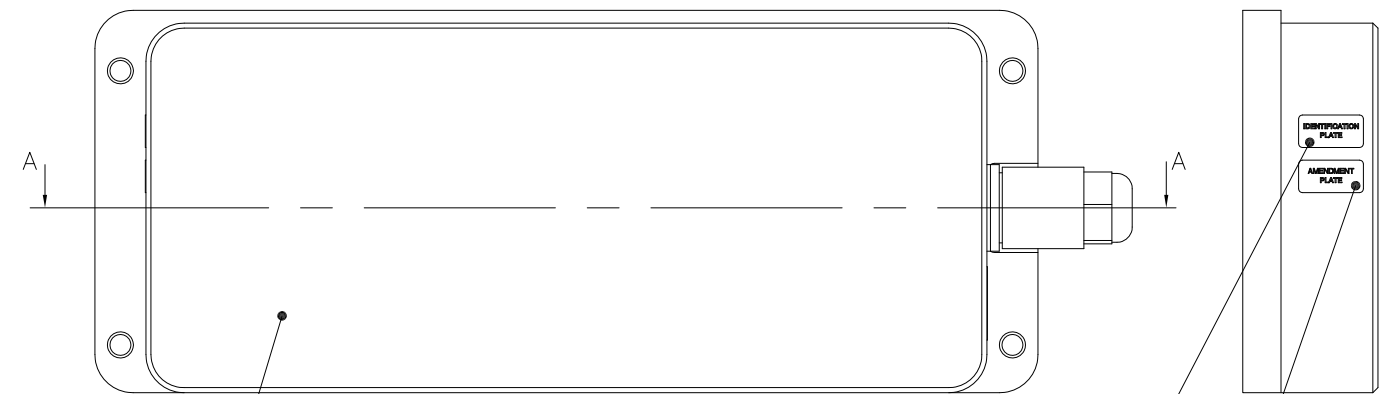

MH2 1

FCC_CE_Plate

MH20 1

MH21 1

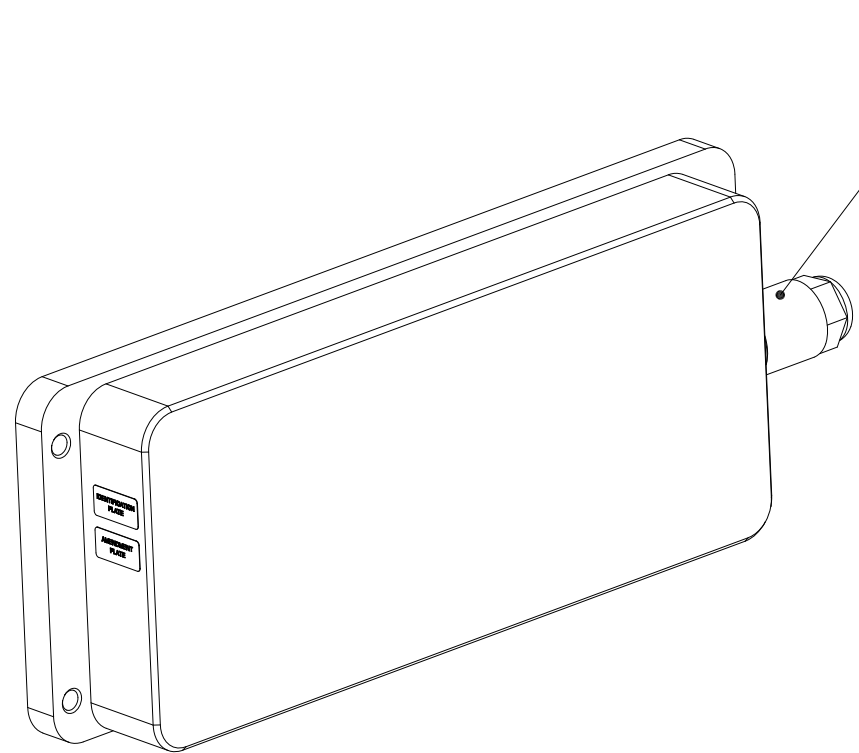

P1 1

SEE NOTE

NOTES:

- ITEM MH18: APPLY TORQUE 0.5 ±0.05 Nm. INSTALL AND TORQUE SCREWS BY CROSSING
- THE MATING CONNECTOR ITEM P1 MUST BE SUPPLIED NON ASSEMBLY IN A SIGLE PACKAGE AND DELIVER WITH THE SENSOR.

The content of this document are proprietary to ROCKWELL COLLINS FRANCE and shall not be disclosed, disseminated, copied or used except for purposes expressly authorized in writing by ROCKWELL COLLINS FRANCE

	ROCKWELL COLLINS FRANCE 6, avenue Didier Daurat BP 20008 31701 BLAGNAC tel: 05-61-71-77-00 telecopie : 05-61-71-51-69		
	NAME PREP RESSIGEAC CHK HATCHONDO APPROVE GALIERE A.Q. BONNEFILLE	DATE 22/03/16 22/03/16 11/07/16 13/07/16	ASSEMBLY DRAWING AUTOCAD V2005 222-3044-098 B