



Ohtama

Test Report

Test Report Number TUVOTEL005
Applied Standard(s) FCC Part15.247 Subpart C / IC RSS-210
Date of Issue 18th Dec, 2012
Testing Laboratory Address TÜV SÜD Ohtama, Ltd. Astronaut Noborito Laboratory
294 Noborito, Tama-ku, Kawasaki-shi, Kanagawa, 214-0014 JAPAN
Test Date(s) 19 November, 2012 to 26 November, 2012
Product Name CYCLO COMPUTER
Model Number SGX-CA900
Serial Number -
Applicant (Client) Address Pioneer Corporation
1-1, Shin-ogura, Saiwai-ku, Kawasaki-shi, Kanagawa-Ken 212-0031
JAPAN
Manufacturer Address Towada Audio Corp.
98 Ohinatsubo, Kosaka-machi Kazuno-gun, Akita-ken 017-0201 JAPAN
FCC ID AJDK-063
IC ID 775E-K063

Test Result

The test result for the electromagnetic compatibility tests as described in the section 1 to 2 and in this page was:

Pass

Tested by: Takaaki Nishimori
Takaaki Nishimori
Test Engineer

Approved by: Koji Imai
Koji Imai
Testing Group Leader

Checked box () indicates that the listed condition, standard or equipment is applicable for this Report. Blank box () indicates that the listed condition, standard or equipment is not applicable for this Report. It is not allowed to copy this report, except in full, without written permission of the test laboratory. Test results of this report refer only to the EUT tested here.



Ohtama

	Page
Cover Page.....	1
Table of Contents.....	2
1. Summary.....	3
1.1 Terms and definitions	3
1.2 Standard(s) and Result.....	4
1.3 Deviations from Standard(s).....	4
2. Equipment Under Test (EUT).....	5
2.1 General Descriptions	5
2.2 Detailed Descriptions.....	5
2.3 Operation Mode(s) of the EUT for EMC during the Test(s)	5
2.4 Peripheral Devices(*).....	5
2.5 Interconnecting Cables ^(†)	5
2.6 System Configuration	6
3. Test Data.....	7
3.1 Test specification.....	7
3.2 99% Bandwidth.....	8
3.3 6dB Bandwidth	9
3.4 Maximum Peak Output Power	10
3.5 Band Edge of Compliance of RF Conducted Emissions.....	11
3.6 Spurious emission at Antenna port.....	12
3.7 Radiated emission	19
3.8 Conducted emission	23
4. Test Setup Photographs.....	26
5. Test facility	29
5.1 Test Instruments.....	29
5.2 Test equipment.....	29
5.3 Normalized Site Attenuation	29
Annex A (Miscellaneous Information)	30
A.1 Test Locations	30
A.2 Uncertainty	30
Annex B (Description of Test Method)	31
B.1 Conducted Emissions (AC Main and Other Terminals)	31
B.2 Radiated Electric-Field Emissions (30 MHz to 1000MHz)	32
B.3 Radiated Electric-Field Emissions above 1000MHz	33
B.4 Radiated Magnetic-Field Emissions	33

1. Summary

1.1 Terms and definitions

AV
Average

DoC
Declaration of Conformity

EUT
Equipment Under Test

PK
Peak

QP
Quasi-peak

1.2 Standard(s) and Result

Applied Standard(s)	Normative Reference(s)	Classification	Result	Note
FCC Part15 Subpart C IC	20dB Bandwidth(FHSS only)	15.247(a)(1) RSS-210 A8.1(a)	N/A	
	6dB Bandwidth(DHSS only)	15.247(a)(2) RSS-210 A8.2(a)	Pass	
	Carrier Frequency Separation (FHSS only)	15.247(a)(1) RSS-210 A8.1(b)	N/A	
	Number of Hopping Frequencies (FHSS only)	15.247(a)(1) RSS-210 A8.1(c)	N/A	
	Time of Occupancy(Dwell Time) (FHSS only)	15.247(a)(1) RSS-210 A8.1(d)	N/A	
	Maximum Peak Output Power	15.247(b)(1)(2)FHSS 15.247(b)(3)DHSS RSS-210 A8.4(2)	Pass	
	Band Edge of Compliance of RF Conducted Emissions	15.247(d) RSS-210 A8.5	Pass	
	26dB and 99% Bandwidth	RSS-Gen4.6.1	Pass	
	Restricted Bands of Operation	15.247(d) RSS-210 2.2	Pass	
	Peak Power Spectral Density (FHSS only)	15.247(e) RSS-210 A8.2(b)	N/A	
	Transmitter spurious emissions (Conducted / Radiated)	15.207 15.209 RSS-Gen 7.2.2	Pass	
	Maximum Permissible Exposure	1.1310 Safety code6, 2.2.1	N/A	

Note1 : This test measured according to the following procedure:FCC publication KDB558074 Measurement of Digital Transmission Systems Operating under Section 15.247 March 23, 2005

1.3 Deviations from Standard(s)

There was no deviation from the standard.

2. Equipment Under Test (EUT)

2.1 General Descriptions

This product is attached to the handlebars of a bicycle by an exclusive clamp, and can communicate with the peripheral equipment corresponding to an ANT standard.
It is a cycle computer which can be displayed on a 2.2-inch liquid crystal display.

2.2 Detailed Descriptions

Product Name	CYCLO COMPUTER
Model Number	SGX-CA900
Serial Number	-
Power Supply	5 V DC
Dimension	70mm(W)×85mm(H)×21.5mm(D)
Operating Frequency	2457MHz
Normal Placement	Bicycle
Specific Requirements	
Condition of the EUT	Prototype

2.3 Operation Mode(s) of the EUT for EMC during the Test(s)

Operation Mode Name	Description
Master	Normal operation TX mode
Slave	Normal operation RX mode

2.4 Peripheral Devices(*)

Mark	Description	Model Number	Serial Number	FCC ID Code or DoC status	Manufacturer
1	AC Adapter	FA65NS0-00	CN-0YT886-73245-7BQ-1480	DoC	Dell

(*): Peripheral Devices were used for Radiated and Conducted Emission tests.

2.5 Interconnecting Cables(*)

Mark	Description	Length (m)	Shielded		Tested Port(s) (Note:1)	
			Cable	Connector	Applicable	Interface
2	USB Cables	0.4	Yes	Yes	No	I/O Signal
3	Antenna Cable	0.19	Yes	Yes	No	R/F Signal

Note1: Tested port(s) required for applicable standard(s).

Remarks:

2.6 System Configuration

Unless otherwise specified in the following sections, the test configuration described here is applied for the tests. The configuration was choice by the applicant.

For Conducted emissions tests,

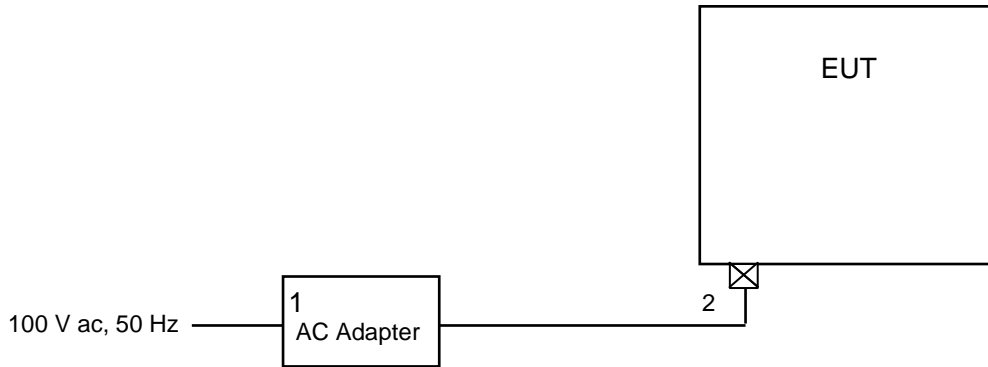

For Radiated emissions tests,

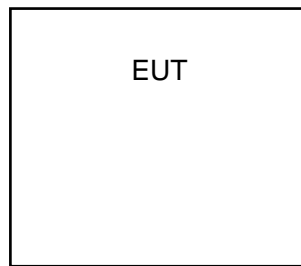

For Spurious emission at Antenna port test

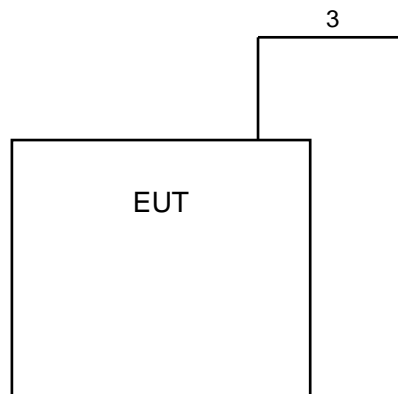

3. Test Data

3.1 Test specification

Standard	FCC Part15.247 Subpart C / IC RSS-210
Frequency Range	2457 MHz
Test Date	19 th , 20 th , 21 st , 22 nd , 26 th November 2012
Test Location	Astronaut Noborito Laboratory Anechoic chamber No.1 Thermostatic chamber
Test Engineer	Takaaki Nishimori,
Temperature	24.0 °C to 25.0°C, 18.0 °C to 18.0°C
Humidity	47.0 % RH to 56.0 % RH, 42.0 % RH to 42 % RH
Pressure	991 hPa to 1005 hPa, 926 hPa to 926 hPa
Power Supply	5V DC
Operation Mode Name	Master(Normal operation TX mode) Slave(Normal operation RX mode)
Tested TX modulation/data rate	
GFSK	1Mbps
Tested channel	2457MHz

Remark: *1 : Equivalent isotropic radiated power and Frequency Range only.

3.2 99% Bandwidth

3.2.1 Test Result

Center Frequency (MHz)
2457

99% Bandwidth (MHz)
1.10

Pass

3.2.2 Test Detail

EUT was tested based on FCC 15.247(a)(1) RSS-210A8.1(a) with temporally antenna port. The bandwidth of frequency is measure by spectrum analyzer with 100kHz RBW and 300kHz VBW. The 20dB bandwidth is defined as the total spectrum the power of which is higher than peak power 20dB.

3.2.3 Test data

99% bandwidth
2457MHz

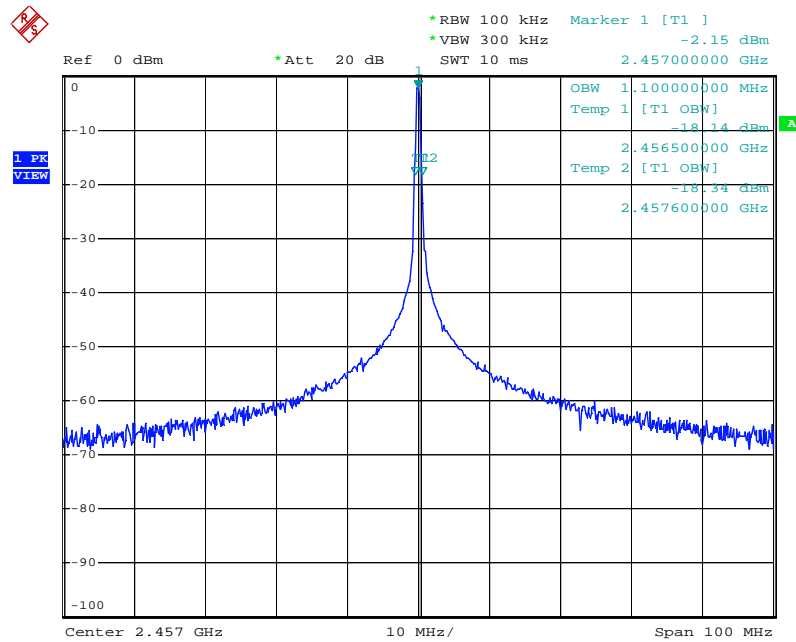

99per_BANDWIDTH
Date: 19.NOV.2012 15:12:11

3.3 6dB Bandwidth

3.3.1 Test Result

**6dB Bandwidth
(MHz)**
0.5070

**Limit
(kHz)**
>500kHz

Pass

3.3.2 Test Detail

EUT was tested based on FCC 15.247(a)(2) RSS-210A8.2(a) with temporarily antenna port. The RBW is set to 100kHz and the VBW is set to 300kHz. The sweep time is coupled.

3.3.3 Test data

6dB bandwidth
2457MHz

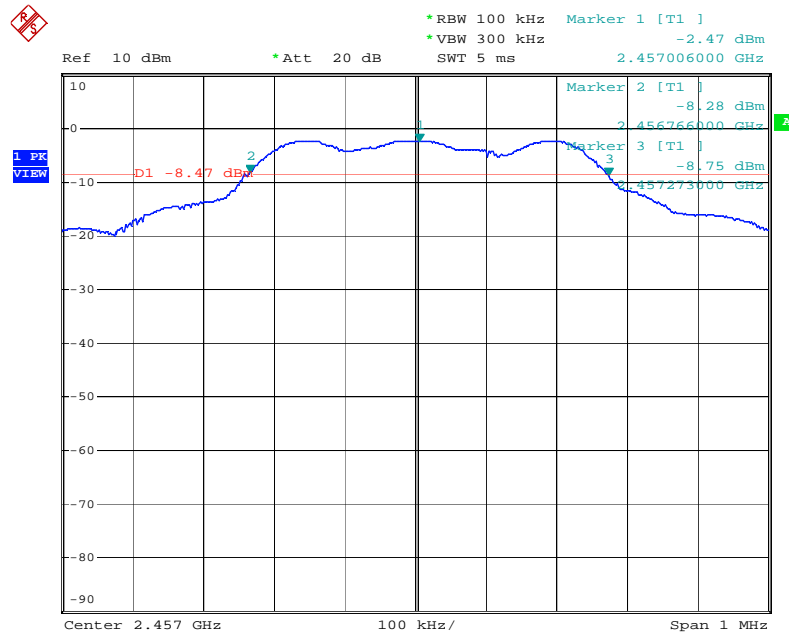

6dB_BANDWIDTH

Date: 19.NOV.2012 15:24:38

3.4 Maximum Peak Output Power

3.4.1 Test Result

2457MHz Frequency (MHz)	Peak power (dBm)	Limit (dBm)	Margin (dB)
2457.7725630	-0.32	≤ 30	30.32

Pass

3.4.2 Test Detail

EUT was tested based on FCC 15.247(b)(1)(2)FHSS 15.247(b)(3)DHSS RSS-210 A8.4(2) with temporally antenna port. The bandwidth of the RF frequency is measured with the spectrum analyzer using 1MHz RBW and 3MHz VBW.

3.4.3 Test data

Maximum Peak Output Power
2457MHz

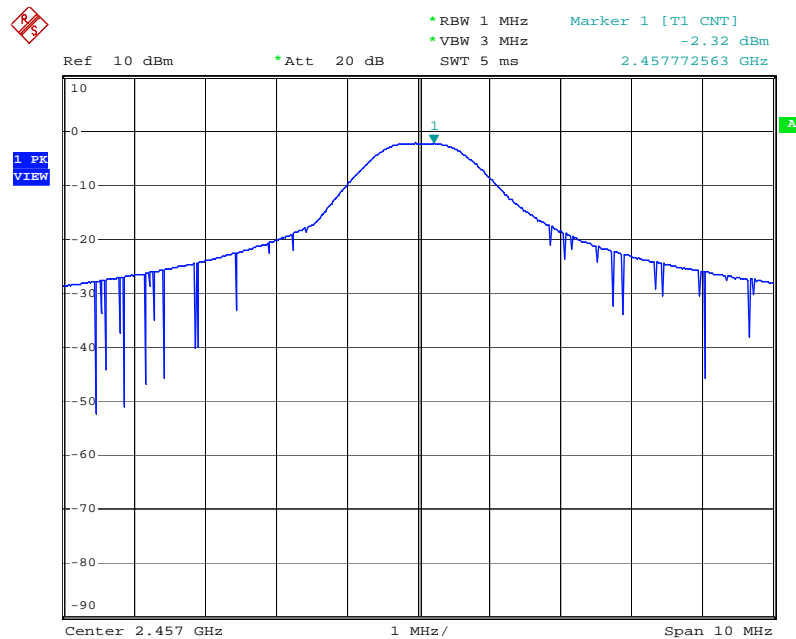

MAX_PK_POW
Date: 19.NOV.2012 16:26:23

3.5 Band Edge of Compliance of RF Conducted Emissions

3.5.1 Test Result

2457MHz

Channel	Frequency (MHz)	Deference (dB)	Limit (dBc)	Margin (dB)
Low	2455.99	34.52	≥ 20	14.52
High	2458.20	33.88	≥ 20	13.88

Pass

3.5.2 Test Detail

EUT was tested based on FCC 15.247(d) RSS-210 A8.5 with temporally antenna port. The spectrum analyzer is set to RBW=100kHz, VBW=100kHz, Detector function=Peak.

3.5.3 Test data

Band Edge of Operation
2457MHz

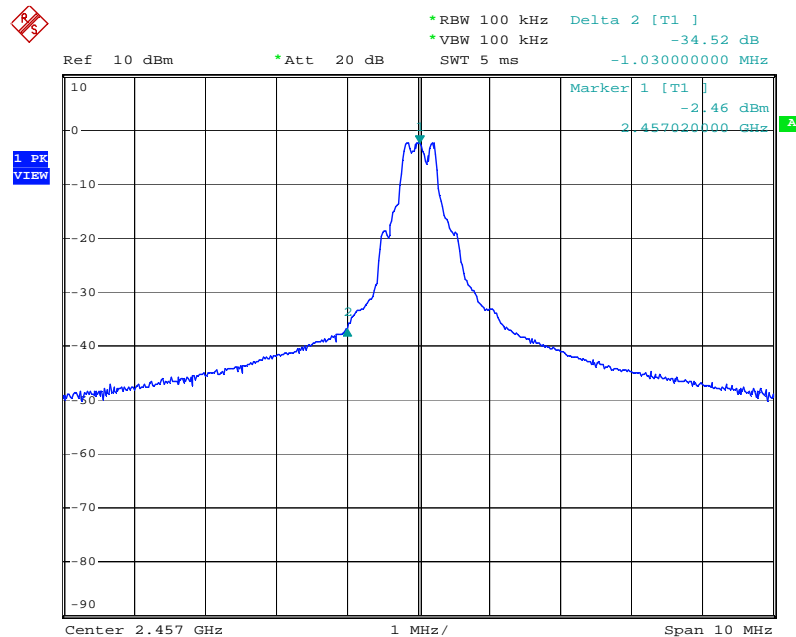

Band_Eg_Comp
 Date: 19.NOV.2012 16:44:56

3.6 Spurious emission at Antenna port

Please refer the Test Data.

Pass

3.6.1 Test Detail

EUT was tested based on FCC 15.207 RSS-210 A8.2(b) with temporally antenna port. Set the Spectrum analyzer on MAX-Hold Mode, and then keep the EUT in transmitting mode. Record all the signals from each channel until each one has been recorded.

3.6.2 Test data

2457MHz Master (TX MODE)

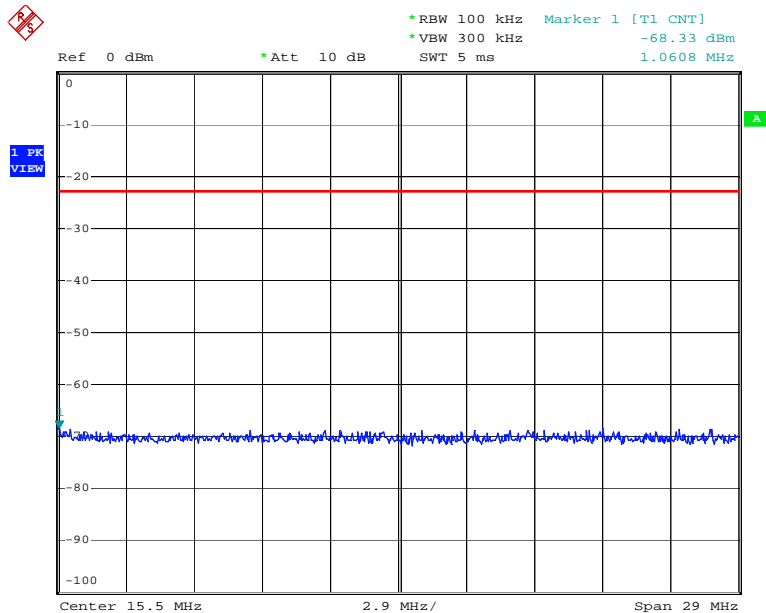

SE_SPU_1MHz-30MHz
Date: 20.NOV.2012 17:03:58

Band1(1MHz-30MHz)

Band2(30M-300MHz)

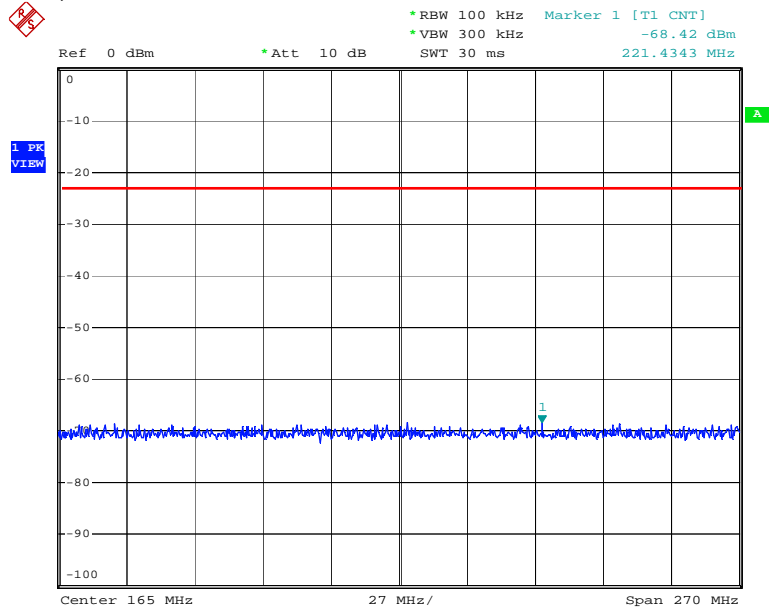

SE_SPU_30MHz-300MHz
Date: 20.NOV.2012 17:01:55

Band3(300MHz-1GHz)

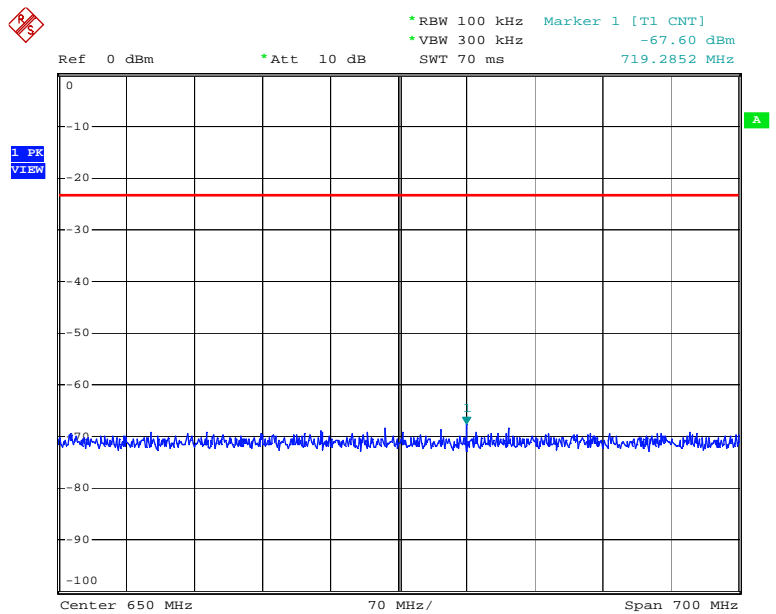

SE_SPU_300MHz-1GHz
Date: 20.NOV.2012 17:05:46

Band4(1GHz-3GHz)

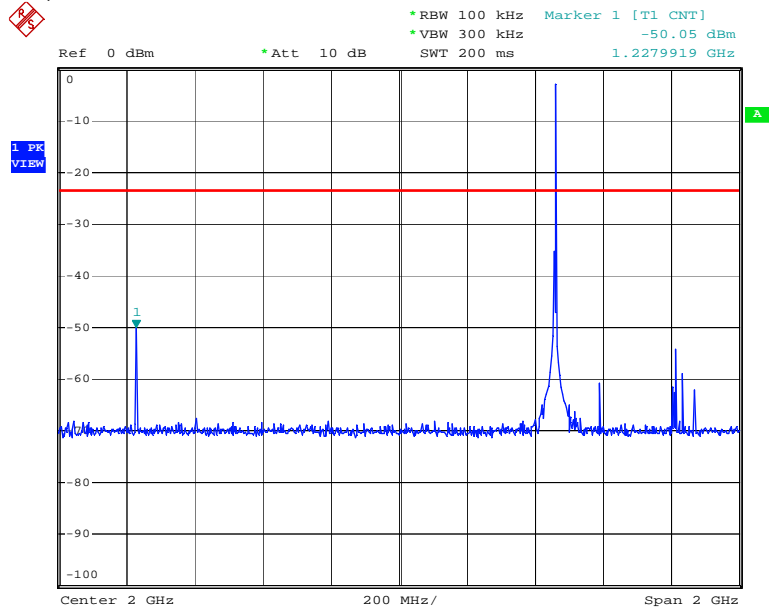

SE_SPU_1GHz-3GHz
Date: 20.NOV.2012 17:08:22

Band5(3GHz-10GHz)

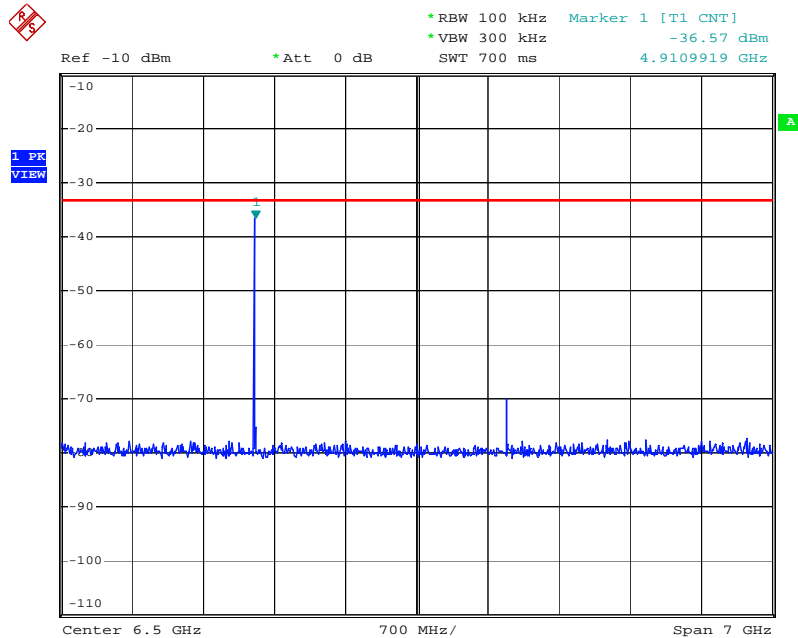

SE_SPU_3GHz-10GHz
Date: 20.NOV.2012 17:09:22

Band6(10GHz-30GHz)

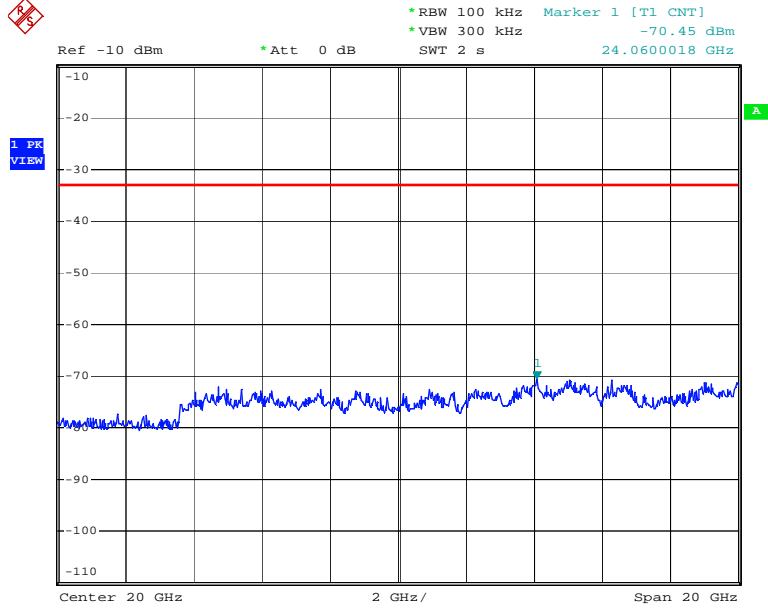

SE_SPU_10GHz-30GHz

Date: 20.NOV.2012 17:10:58

2457MHz Slave (RX MODE)
Band1(1MHz-30MHz)

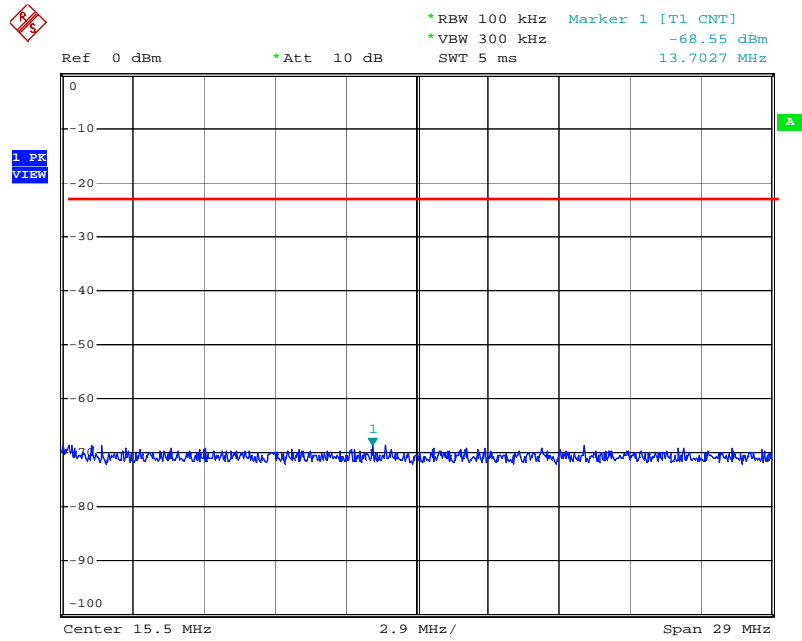

RV_SPU_1MHz-30MHz
Date: 20.NOV.2012 16:44:52

Band2(30M-300MHz)

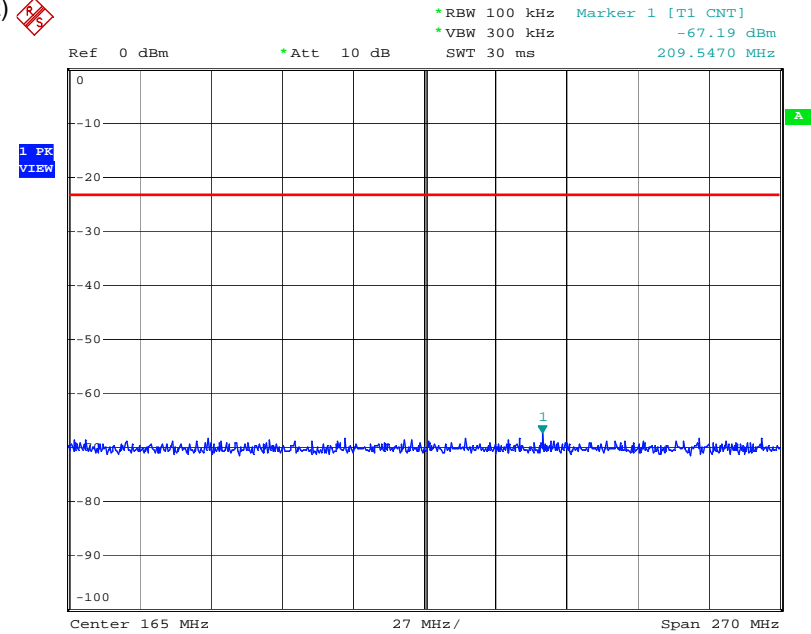

RV_SPU_30MHz-300MHz
Date: 20.NOV.2012 16:46:36

Band3(300MHz-1GHz)

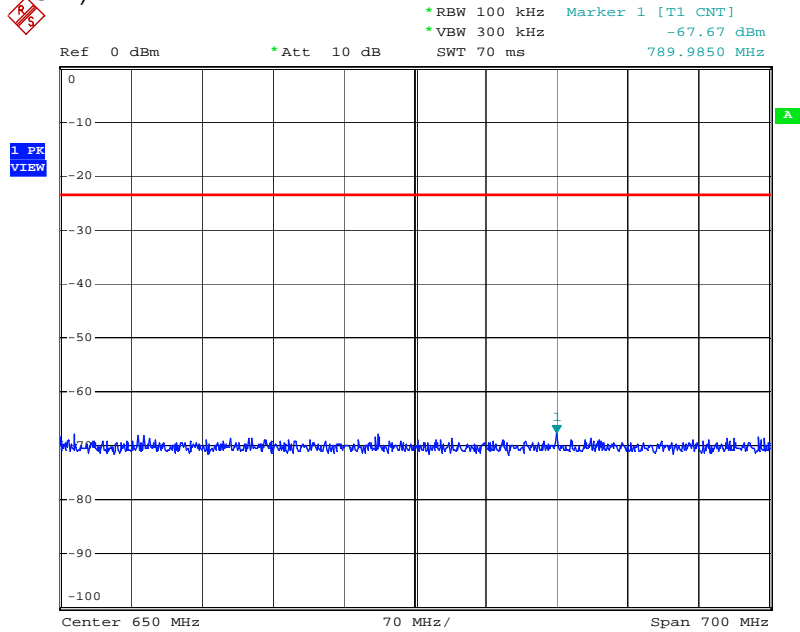

RV_SPU_300MHz-1GHz
Date: 20.NOV.2012 16:47:50

Band4(1GHz-3GHz)

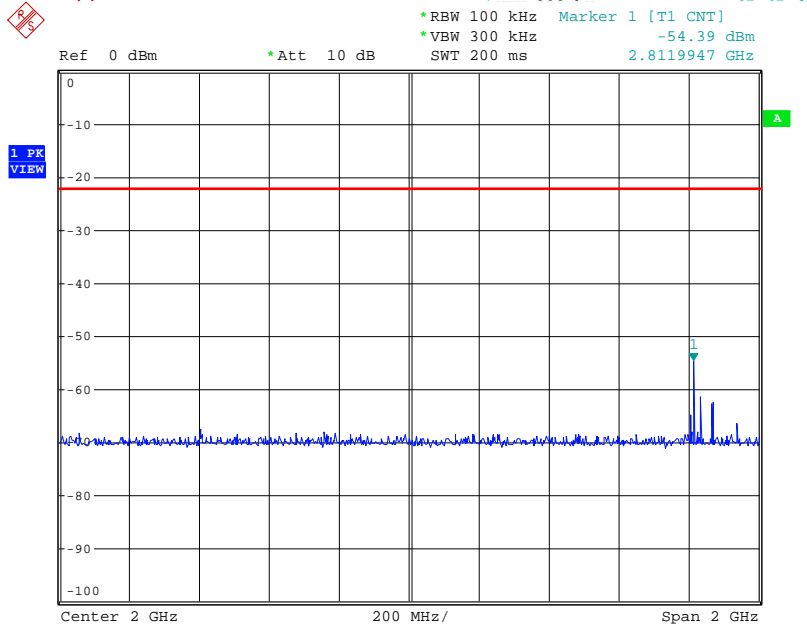

RV_SPU_1GHz-3GHz
Date: 20.NOV.2012 17:22:23

Band5(3GHz-10GHz)

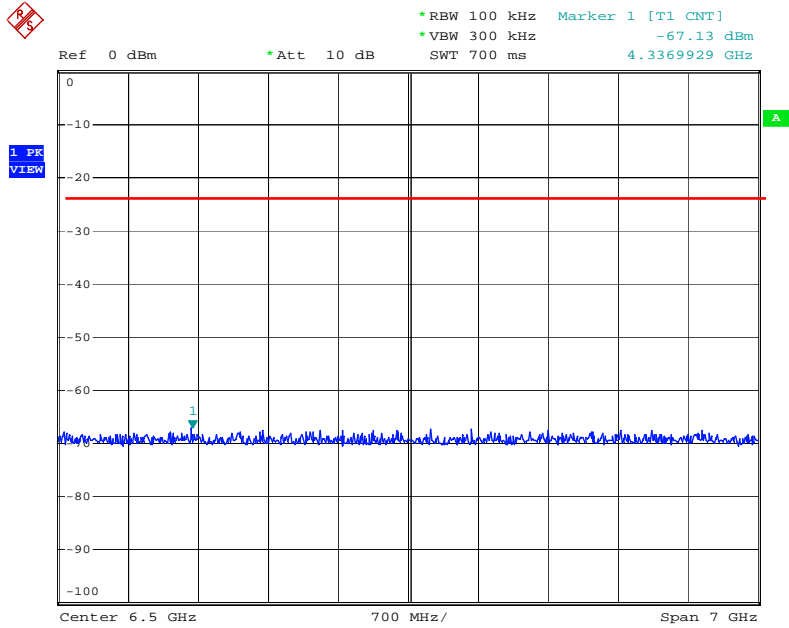

RV_SPU_3GHz-10GHz

Date: 20.NOV.2012 16:52:52

Band6(10GHz-30GHz)

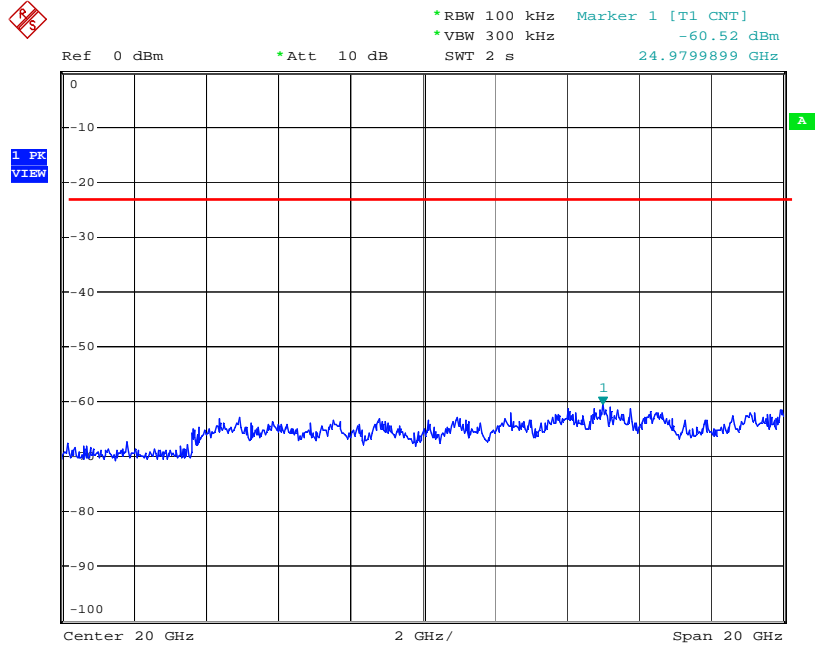

RV_SPU_10GHz-30GHz

Date: 20.NOV.2012 16:55:15

3.7 Radiated emission

3.7.1 Test Result

Pass

3.7.2 Test Detail

EUT was tested based on FCC 15.209 RSS-210 A8.2(b) with antenna.
See Annex B.

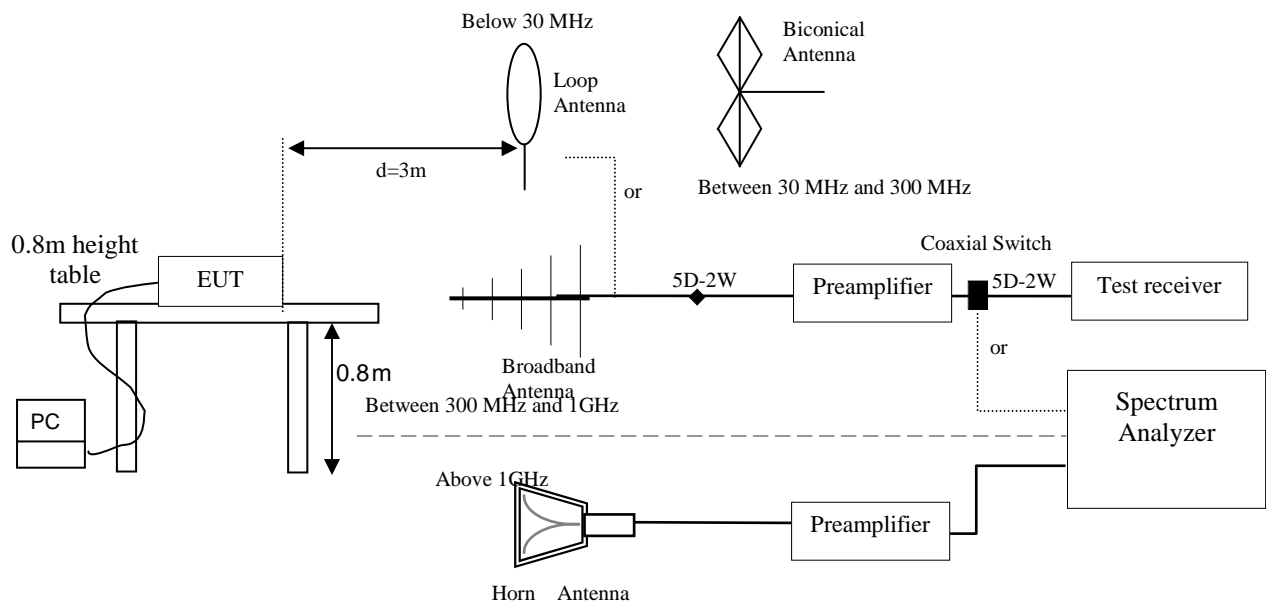

3.7.3 Test data

Measurement Data 1M- 30MHz (3m)

Radiated Electric-Field (3m) — Horizontal

Frequency Reading (MHz)	Reading (dB μ V)	Correction factor (dB/m)	Noise level (dB μ V/m)	Limit (dB μ V/m)	Margin (dB)
12.89	37.8	0.43	38.2	39.0	0.8

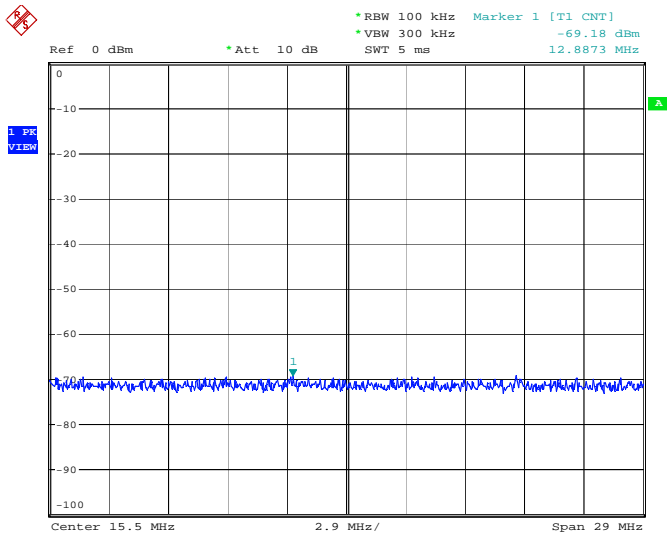

SE_1MHz-30MHz
 Date: 26.NOV.2012 18:23:50

Measurement Data 30M- 300MHz (3m)

Radiated Electric-Field (3m) — Horizontal

Frequency (MHz)	Reading (dBμV)	Correction factor (dB/m)	Noise level (dBμV/m)	Limit (dBμV/m)	Margin (dB)
224.13	38.9	2.0	40.9	46.0	5.1

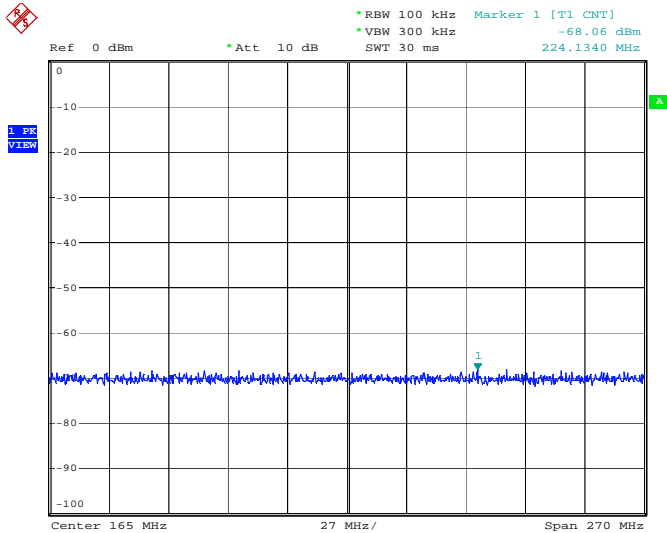

SE_30MHz-300MHz
 Date: 26.NOV.2012 16:08:05

Measurement Data 300M-1GHz (3m)

Radiated Electric-Field (3m) — Horizontal

Frequency (MHz)	Reading (dB μ V)	Correction factor (dB/m)	Noise level (dB μ V/m)	Limit (dB μ V/m)	Margin (dB)
804.00	38.62	3.81	42.4	46.0	3.6

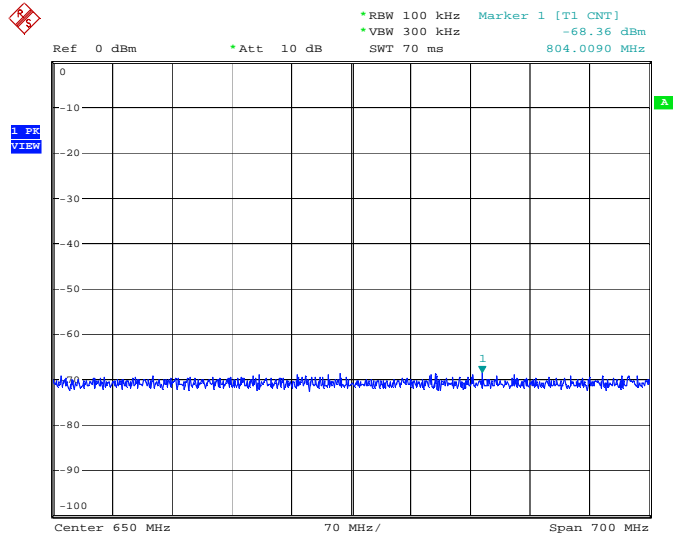

SE_300MHz-1GHz

Date: 26.NOV.2012 16:16:23

Measurement Data 1G-3GHz (3m)

Radiated Electric-Field (3m) — Horizontal

Frequency (MHz)	Reading (dB μ V)	Correction factor (dB/m)	Noise level (dB μ V/m)	Limit (dB μ V/m)	Margin (dB)
2,261.97	39.7	6.4	46.1	54.0	7.9

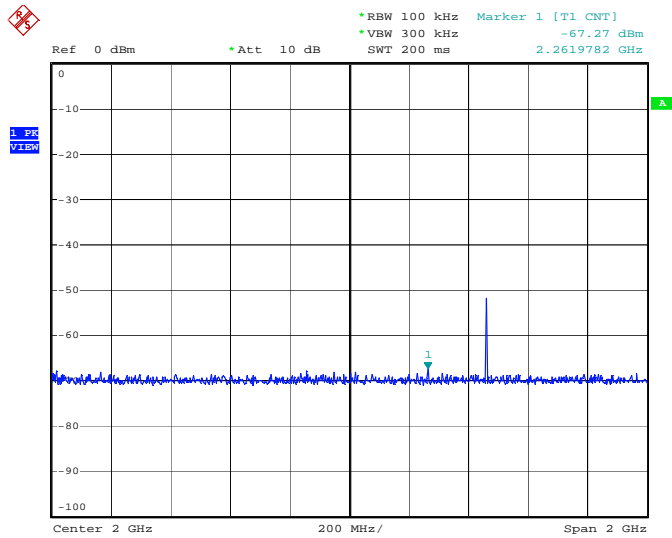

SE_SPU_1GHz-3GHz
 Date: 22.NOV.2012 18:55:07

Measurement Data 3G-10GHz (3m)

Radiated Electric-Field (3m) — Horizontal

Frequency Reading (MHz)	Reading (dBμV)	Correction factor (dB/m)	Noise level (dBμV/m)	Limit (dBμV/m)	Margin (dB)
4,252.99	29.8	9.1	38.9	54.0	15.1

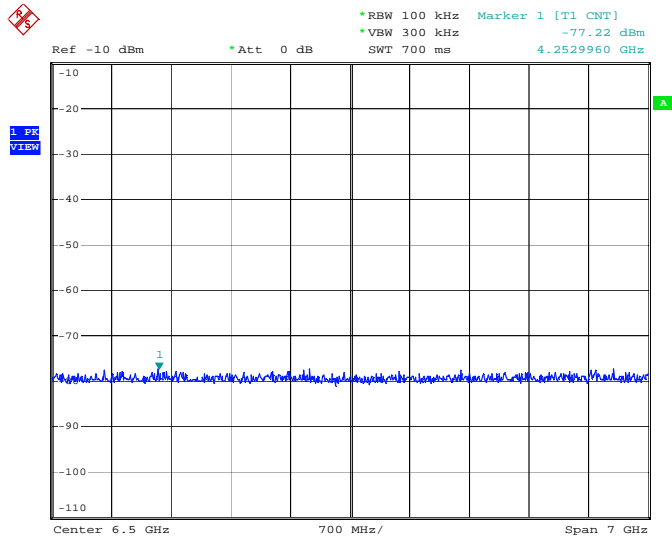

SE_SPU_3GHz-10GHz
 Date: 22.NOV.2012 18:56:44

Measurement Data 10G-30GHz (3m)

Radiated Electric-Field (3m) — Horizontal

Frequency Reading (MHz)	Correction (dB μ V)	Noise level factor (dB/m)	(dB μ V/m)	Limit (dB μ V/m)	Margin (dB)
----------------------------	----------------------------	------------------------------	----------------	-------------------------	----------------

24,940.01	36.68	12.1	48.8	54.0	5.2
-----------	-------	------	------	------	-----

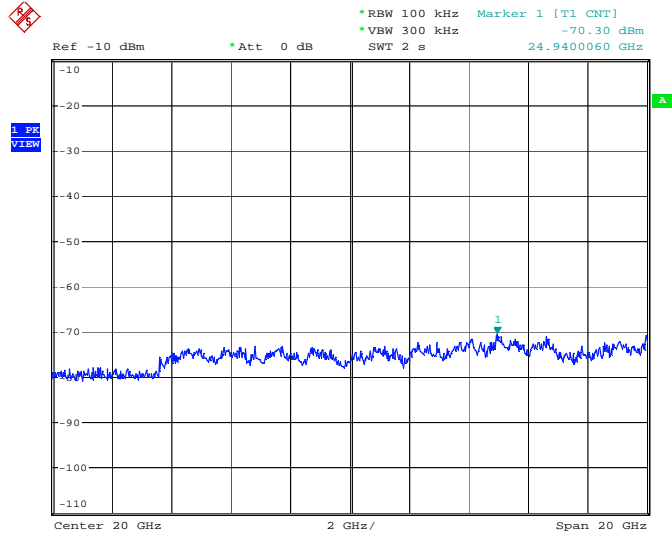

SE_SPU_10GHz-30GHz

Date: 22.NOV.2012 18:58:02

3.8 Conducted emission

3.8.1 Test Result

Pass

3.8.2 Test Detail

EUT was tested based on FCC 15.207 RSS-210 A8.2(b) with USB Charge port.
See Annex B.

3.8.3 Test data

Master Operation 1 (L)

--- L1 Phase ---

No.	Frequency [MHz]	Reading QP [dB(μV)]	Reading AV [dB(μV)]	c. f [dB]	Result QP [dB(μV)]	Result AV [dB(μV)]	Limit QP [dB(μV)]	Limit AV [dB(μV)]	Margin QP [dB]	Margin AV [dB]
1	0.20744	36.2	26.4	9.8	46.0	36.2	63.3	53.3	17.3	17.1
2	0.25234	33.8	23.8	9.8	43.6	33.6	61.7	51.7	18.1	18.1
3	0.29764	28.0	18.8	9.9	37.9	28.7	60.3	50.3	22.4	21.6
4	0.59198	21.8	13.5	10.2	32.0	23.7	56.0	46.0	24.0	22.3

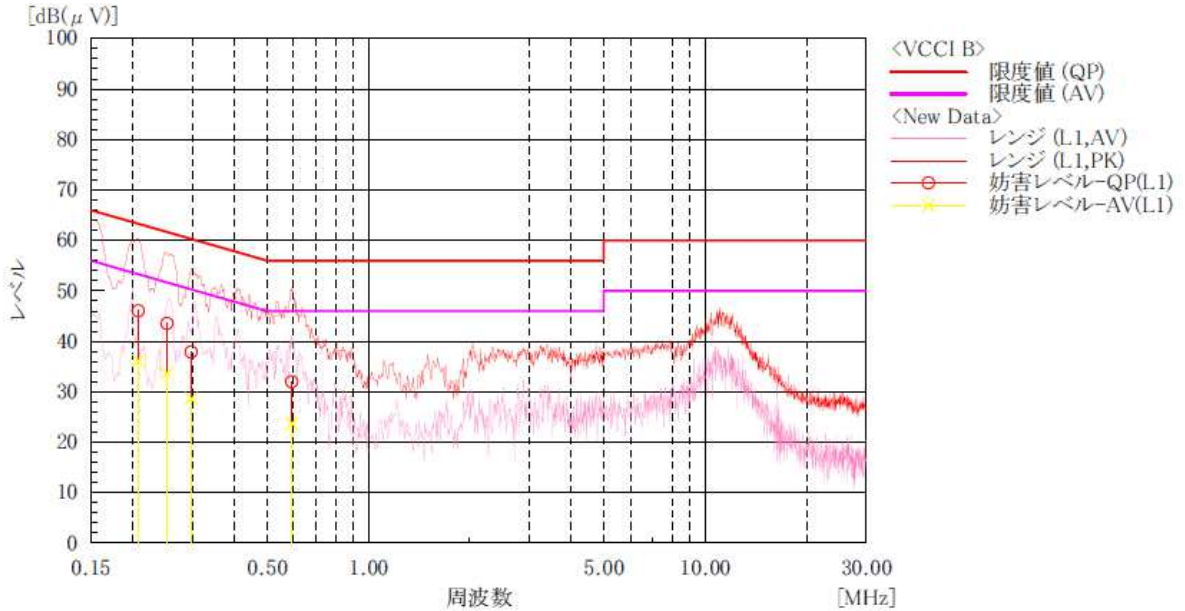

Master Operation 1 (N)

--- N Phase ---										
No.	Frequency	Reading QP	Reading AV	c. f	Result QP	Result AV	Limit QP	Limit AV	Margin QP	Margin AV
	[MHz]	[dB(μV)]	[dB(μV)]	[dB]	[dB(μV)]	[dB(μV)]	[dB(μV)]	[dB(μV)]	[dB]	[dB]
1	0.2016	37.4	25.6	9.9	47.3	35.5	63.5	53.5	16.2	18.0
2	0.25447	35.4	25.6	9.9	45.3	35.5	61.6	51.6	16.3	16.1
3	0.30681	33.8	23.0	9.9	43.7	32.9	60.1	50.1	16.4	17.2
4	0.34997	30.1	19.8	9.9	40.0	29.7	59.0	49.0	19.0	19.3
5	0.58396	29.5	24.2	10.2	39.7	34.4	56.0	46.0	16.3	11.6
6	0.64115	27.1	21.2	10.2	37.3	31.4	56.0	46.0	18.7	14.6

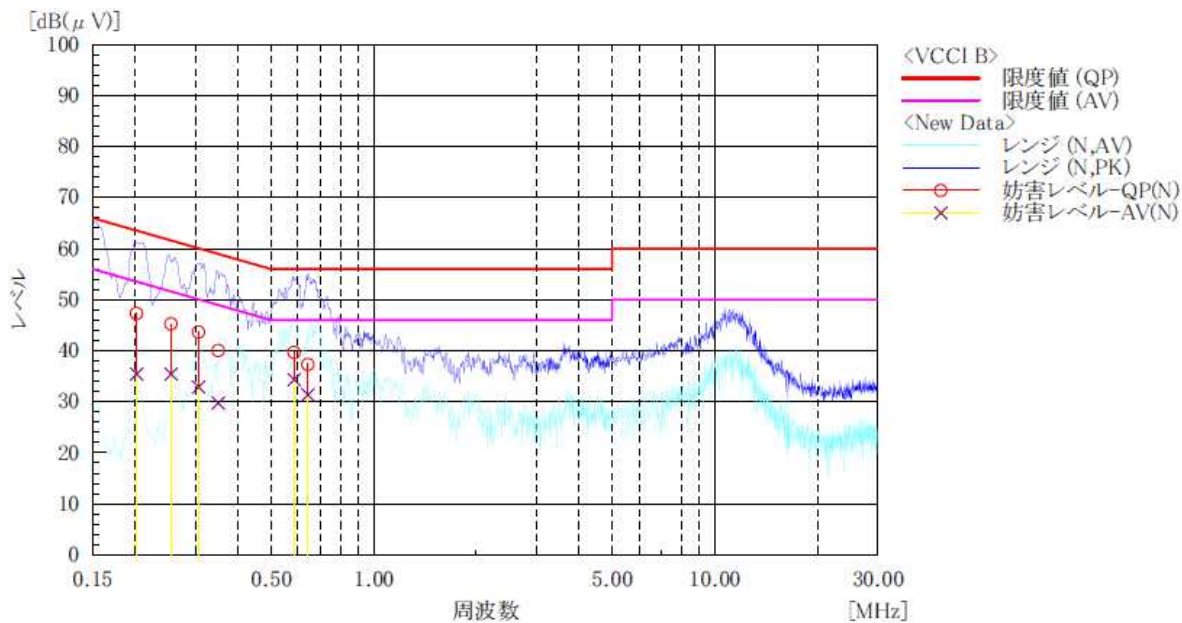

4. Test Setup Photographs

For Conducted emission

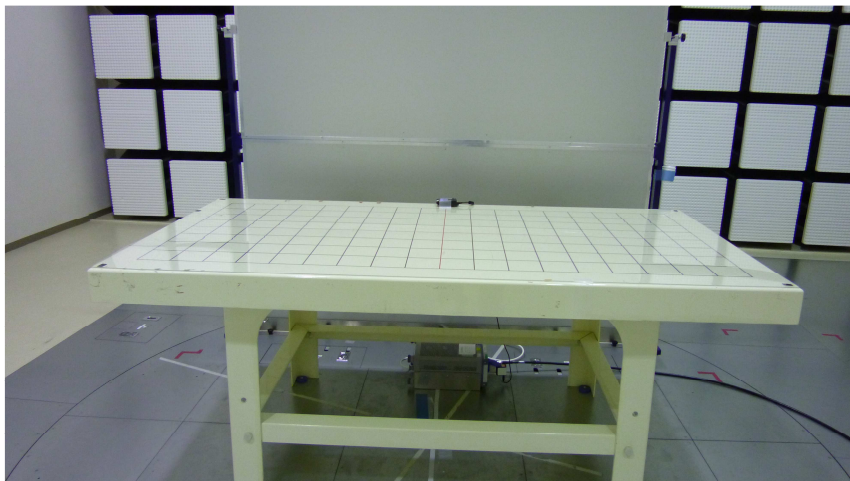

(Front view)



(Side view)

For Radiated emission

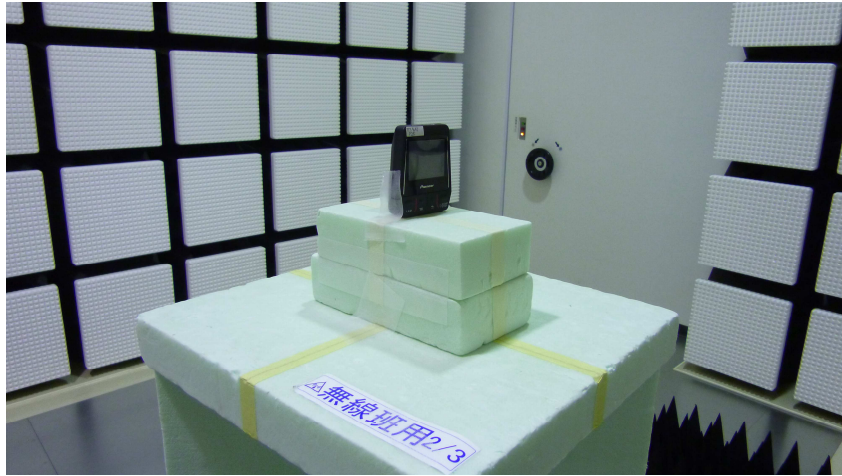

(Zoomin view)

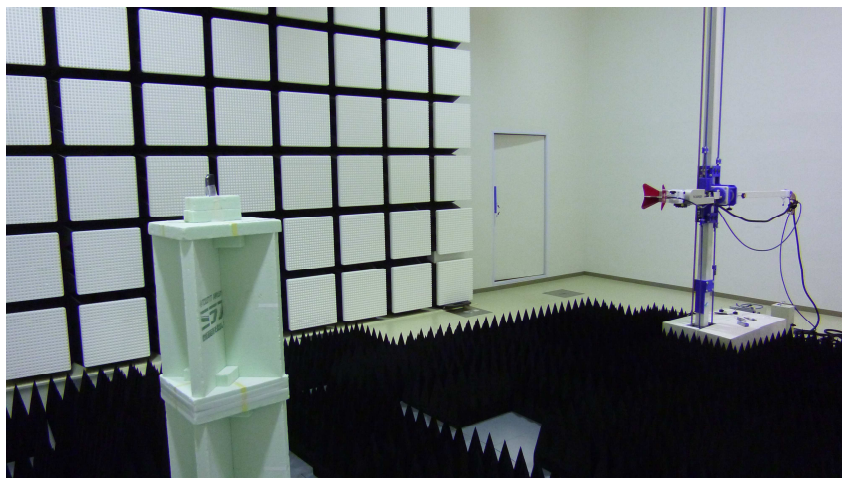
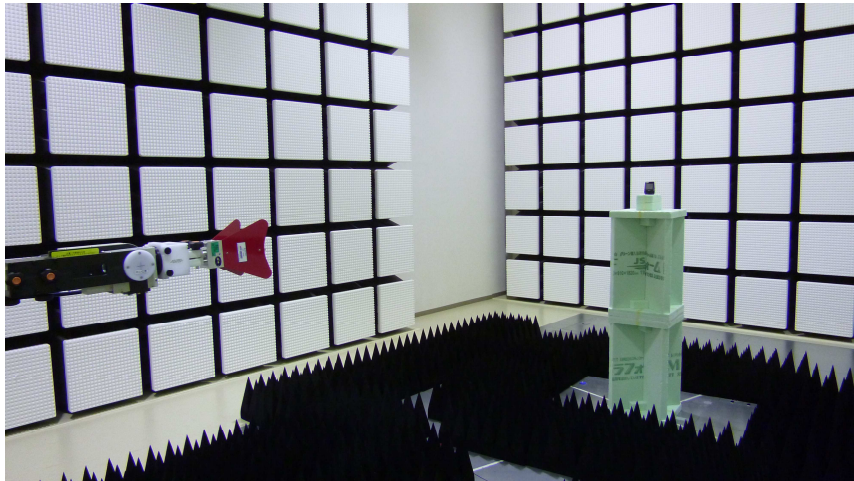

(Zoomout view)

For Spurious emission at Antenna port

Conducted emission at antenna port

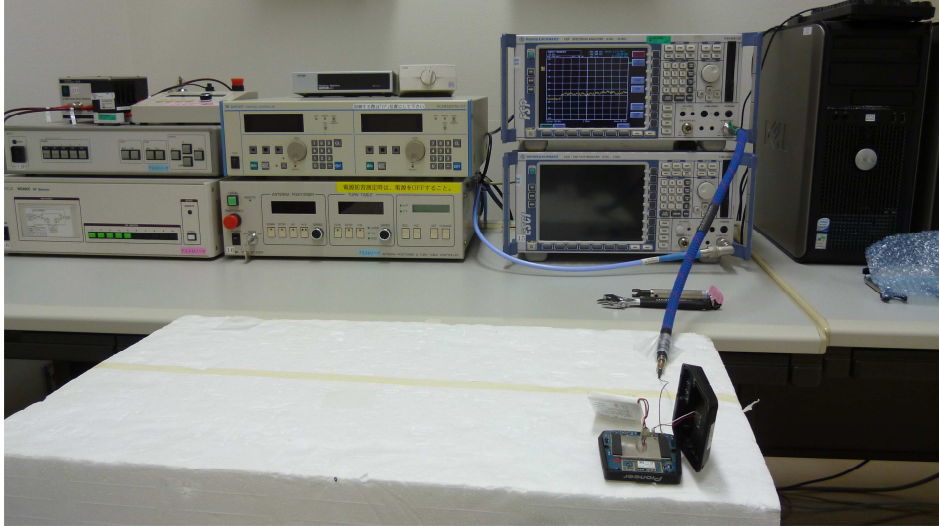

5. Test facility

5.1 Test Instruments

5.1.1 Conducted Emissions

Product Name	Manufacturer	Model Number	Serial Number	Calibration Date	Due Date
Spectrum Analyzer	Rohde&Schwarz	FSP30	100778	2012/4/12	2013/4/30
Cable	Pasternack Enterprises, Inc.	PE315-24	3108	2012/7/17	2013/7/31
Spectrum Analyzer	Rohde&Schwarz	ESCI	100485	2012/10/05	2013/10/31
Receiver	Rohde&Schwarz	ESCI	100485	2012/10/05	2013/10/31
LISN	Rohde&Schwarz	ENV-216	100466	2012/10/25	2013/10/31

5.1.2 Radiated Electric-Field Emissions

Product Name	Manufacturer	Model Number	Serial Number	Calibration Date	Due Date
Spectrum Analyzer	Rohde&Schwarz	FSP30	100778	2012/4/12	2013/4/30
Cable	Mini-Circuits	CBL-25FT-NMNM+	65678	2012/11/8	2013/11/30
Loop Antenna	EMCO	6507	9108-1268	2011/11/28	2012/11/30
Biconical Antenna	Schwarzbeck	BBA9106	91032511	2012/5/8	2013/5/31
Logperidodec Antenna	Schwarzbeck	UHALP9108A	812	2012/6/14	2013/6/30
Horn Antenna	ETS-LINDGREN	3117	146463	2012/4/10	2013/4/30

5.2 Test equipment

Dimension	Material	Measurement
0.4m (W) X 1.5m (H) X 0.4m (D)	styrene form	Spurious emission at Antenna port
1.5m (W) X 0.8m (H) X 1.0m (D)	polystyrene	Conducted Emissions
1.5m (W) X 0.8m (H) X 1.0m (D)	polystyrene	Radiated Electric-Field Emissions

5.3 Normalized Site Attenuation

Site Name	Laboratory	Calibration Date	Due Date
Semi-Anechoic chamber No.1	Noborito Laboratory	2012/7/27	2013/7/31

Annex A (Miscellaneous Information)

A.1 Test Locations

Unless otherwise described in this report, the tests were carried out at the following locations:

TÜV SÜD Ohtama, Ltd., Astronaut Noborito Laboratory
294 Noborito, Tama-ku Kawasaki-shi, Kanagawa, Japan
TEL: +81-44-819-8601
FAX: +81-44-819-8603

FCC Registration Number: 946479
No.1 Semi-Anechoic chamber R-2577, G-130, C-3325, T-1669

TÜV SÜD Ohtama, Ltd., Ashigawa Laboratory
1661 Ohshuku, Ashigawa-cho, Fuefuki-shi, Yamanashi-ken, Japan
TEL: +81-55-298-2141
FAX: +81-55-298-2125

VLAC Attestation No.: VLAC-018-2
VCCI Registration No.:
No.1 Open test site A-0011
No.2 Open test site A-0011
No.3 Open test site R-658 C-675 T-1685 G-5

A.2 Uncertainty

Emissions

Measurement	Uncertainty ($k = 2$)
	U_{lab}
RF Conducted Emissions (150kHz-30MHz)	
AMN	3.5dB
Radiated Electromagnetic Field	
30-1000MHz	5.0dB
1-18GHz	5.3dB

Tests not listed above

Uncertainty for other tests which are reported in this test report, if any, would be available on request.

Furthermore, component and process variability of devices similar to that tested may result in additional deviation. The manufacturer has the sole responsibility of continued compliance of the device.

Annex B (Description of Test Method)

Unless otherwise described in this report, tests are carried out using the methods which are described in the applied standards and summarized in this section.

Specifically for 47 CFR 15 Subpart B, section 6 of ANSI C63.4-2003 is to be used for EUT arrangements and operations, and section 8 of the standard is to be used for radiated emissions measurement procedures.

B.1 Conducted Emissions (AC Main and Other Terminals)

Table-top EUT is placed on a wooden table so that one side (rear or bottom) of the EUT is separated 0.4 m from the reference plane (metallic wall or ground plane), and floor-standing EUT is placed on the ground plane. Mains to the EUT is supplied through a LISN, and mains to non-EUT components, if any, are supplied through yet another LISN(s).

If LISN is not applicable, mains would be supplied directly and a voltage probe would be used instead for the measurement.

For each current-carrying conductors or terminals to be measured, a spectrum analyzer is used to pre-scan the emissions.

For each of the significant emissions detected, the maximum signal level is read using a measuring receiver having CISPR 16 quasi-peak (QP) and average (AV) detector function and 9 kHz nominal bandwidth.

Then, appropriate correction factor —consists of transducer (LISN or voltage probe) factor and transmission loss (due to the attenuator, filter and/or transient suppressor, if any, and the cable) in the system— is applied to the receiver reading to calculate the corresponding emission level.

For example, if reading on the receiver is 33.0 dB μ V, the transducer factor is 0.5 dB, and transmission loss (attenuation) in the coaxial cable and the attenuator is 10.5 dB, the emission level is calculated as:

33.0 dB μ V + 0.5 dB + 10.5 dB = 44.0 dB μ V.

Finally, the calculated emission level is compared with the upper limit specified in the standard.

Actual measurement will be carried out according to the appropriate edition of CISPR 16-2-1, CISPR 22, and ANSI C63.4 and/or other standards whichever applicable.

Specifically for 47 CFR 15 Subpart B, section 6 of ANSI C63.4-2003 is to be used for EUT arrangements and operations, and section 8 of the standard is to be used for radiated emissions measurement procedures.

B.2 Radiated Electric-Field Emissions (30 MHz to 1000MHz)

EUT is placed on a turn-table in a test site, on a table (styrene form) 0.8 m height or on the floor unless otherwise specified in the standard.

Receiving antenna ---usually biconical, log-periodic or biconical/log-periodic hybrid---is positioned at the specified distance from the EUT.

For each polarization (horizontal and vertical), a spectrum analyzer is used to pre-scan the emissions while rotating the turn-table.

For each of the significant electromagnetic field detected, the test personnel discriminates EUT's emissions from the ambient noises.

For each of the significant emissions, maximum level of the emission is searched while rotating the turn-table and varying the antenna height between 1 m and 4 m, and the maximum signal level is read using a measuring receiver having CISPR 16 quasi-peak (QP) detector function and 120 kHz nominal bandwidth.

Then, appropriate correction factor ---consists of antenna factor, amplifier gain and transmission loss (due to the attenuator and the cable loss) in the system--- is applied to the receiver reading to calculate the corresponding field strength.

For example, if reading on the receiver is 33.0 dB μ V, the antenna factor is 9.4 dB (1/m), the amplifier gain is 25.6 dB, and transmission loss (attenuation) in the coaxial cable and the attenuator is 6.5 dB, the field strength is calculated as: 33.0 dB μ V + 9.4 dB (1/m) - 25.6 dB + 6.5 dB = 23.3 dB μ V/m.

Finally, the calculated field strength is compared with the upper limit specified in the standard.

Actual measurement will be carried out according to the appropriate edition of CISPR 16-2-3, CISPR 22, and ANSI C63.4 and/or other standards whichever applicable.

Specifically for 47 CFR 15 Subpart B, section 6 of ANSI C63.4-2003 is to be used for EUT arrangements and operations, and section 8 of the standard is to be used for radiated emissions measurement procedures.

B.3 Radiated Electric-Field Emissions above 1000MHz

EUT is placed on a turn-table in a test site, on a table (styrene foam) 0.8 m height or on the floor unless otherwise specified in the standard.

Receiving antenna ---usually double ridge waveguide horn or standard horn--- is positioned at the specified distance from the EUT.

For each polarization (horizontal and vertical), a spectrum analyzer is used to pre-scan the emissions while rotating the turn-table.

For each of the significant electromagnetic field detected, the test personnel discriminates EUT's emissions from the ambient noises.

For each of the significant emissions, maximum level of the emission is searched while rotating the turn-table and varying the antenna height if it is required, and the maximum signal level is read using a spectrum analyzer or a measuring receiver having peak detector function and 1 MHz nominal bandwidth, unless otherwise specified in the standard. To obtain average readings with spectrum analyzers, video averaging (usually with VBW = 10 Hz) may be used.

As specified in the applicable standard, the antenna height would be (1) varied between 1 m and 4 m, or (2) varied so that the whole height of the EUT is covered by the main lobe of the receiving antenna, or (3) fixed to the approximate radiation center of the EUT.

Then, appropriate correction factor ---consists of antenna factor, amplifier gain and transmission loss (due to the attenuator and the cable loss) in the system--- is applied to the spectrum analyzer/receiver reading to calculate the corresponding field strength, and the result is compared with the upper limit specified in the standard.

Actual measurement will be carried out according to the appropriate edition of CISPR 16-2-3, CISPR 22, ANSI C63.4 and/or other standards whichever applicable.

Specifically for 47 CFR 15 Subpart B, section 6 of ANSI C63.4-2003 is to be used for EUT arrangements and operations, and section 8 of the standard is to be used for radiated emissions measurement procedures.

B.4 Radiated Magnetic-Field Emissions

EUT is placed on a turn-table in a test site, on a (styrene foam) table 0.8 m height or on the floor unless otherwise specified in the standard.

Receiving antenna ---loop antenna (active or passive) --- is positioned at the specified distance from the EUT.

A spectrum analyzer is used to pre-scan the emissions while rotating the turn-table.

For each of the significant electromagnetic field detected, the test personnel discriminates EUT's emissions from the ambient noises.

For each of the significant emissions, maximum level of the emission is searched while rotating the turn-table and rotating the receiving antenna about its center, and the maximum signal level is read using a measuring receiver having CISPR 16 quasi-peak (QP) detector function and 120 kHz nominal bandwidth.

Then, appropriate correction factor ---consists of antenna factor, and transmission loss (cable loss) in the system-- is applied to the receiver reading to calculate the corresponding field strength, and the result is compared with the upper limit specified in the standard.

In general, it is assumed that magnetic field strength can be converted to electric field strength by applying the free space impedance of approximately 377 ohms, and vice versa.

Actual measurement will be carried out according to the appropriate edition of CISPR 16-2-3, ANSI C63.4 and/or other standards whichever applicable.