

TEST REPORT

of

FCC Part 15 Subpart C

New Application; Class I PC; Class II PC

Product : HOMESCREEN
Brand: SECURIFI
Model: Router + Automation Hub
Model Difference: N/A
FCC ID: AHLCA1
FCC Rule Part: §15.249, Cat:DXX
Applicant: SECURIFI LTD.
Address: 4F,No.65,Songde Rd, Xinyi Dist.Taipei City
110,Taiwan (R.O.C)

Test Performed by:

International Standards Laboratory

<Lung-Tan LAB>

*Site Registration No.

BSMI: SL2-IN-E-0013; MRA TW1036; TAF: 0997; IC: IC4067B-3;

*Address:

No. 120, Lane 180, San Ho Tsuen, Hsin Ho Rd.

Lung-Tan Hsiang, Tao Yuan County 325, Taiwan

*Tel : 886-3-407-1718; Fax: 886-3-407-1738

Report No.: **ISL-14LR240FCDXX**

Issue Date : **2014/11/07**



Test results given in this report apply only to the specific sample(s) tested and are traceable to national or international standard through calibration of the equipment and evaluating measurement uncertainty herein.

This report MUST not be used to claim product endorsement by TAF, NVLAP or any agency of the Government.

This test report shall not be reproduced except in full, without the written approval of International Standards Laboratory.

VERIFICATION OF COMPLIANCE

Applicant: SECURIFI LTD.
Product Description: HOMESCREEN
Brand Name: SECURIFI
Model No.: Router + Automation Hub
Model Difference: N/A
FCC ID: AHLCA1
FCC Rule Part: §15.249, Cat:DXX
Date of test: 2014/10/07 ~ 2014/11/06
Date of EUT Received: 2014/10/07

We hereby certify that:

All the tests in this report have been performed and recorded in accordance with the standards described above and performed by an independent electromagnetic compatibility consultant, International Standards Laboratory.

The test results contained in this report accurately represent the measurements of the characteristics and the energy generated by sample equipment under test at the time of the test. The sample equipment tested as described in this report is in compliance with the limits of above standards.

Test By: Dion Chen **Date:** 2014/11/07
Dion Chang / Engineer

Prepared By: Gigi yeh **Date:** 2014/11/07
Gigi Yeh / Specialist

Approved By: Vincent Su **Date:** 2014/11/07
Vincent Su / Technical Manager

Version

Version No.	Date	Description
00	2014/11/07	Initial creation of document

Table of Contents

1.	GENERAL INFORMATION	5
1.1.	PRODUCT DESCRIPTION	5
1.2.	RELATED SUBMITTAL(S) / GRANT (S)	8
1.3.	TEST METHODOLOGY.....	8
1.4.	TEST FACILITY	8
1.5.	SPECIAL ACCESSORIES	8
1.6.	EQUIPMENT MODIFICATIONS	8
2.	SYSTEM TEST CONFIGURATION	9
2.1.	EUT CONFIGURATION.....	9
2.2.	EUT EXERCISE	9
2.3.	TEST PROCEDURE.....	9
2.4.	LIMITATION	10
2.5.	CONFIGURATION OF TESTED SYSTEM.....	12
3.	SUMMARY OF TEST RESULTS	13
4.	CONDUCTED EMISSIONS TEST	14
4.1	MEASUREMENT PROCEDURE:	14
4.2	TEST SET-UP (BLOCK DIAGRAM OF CONFIGURATION)	14
4.3	MEASUREMENT EQUIPMENT USED:	14
4.4	MEASUREMENT RESULT:	14
5.	RADIATED EMISSION TEST (TX,RX)	17
5.1	MEASUREMENT PROCEDURE.....	17
5.2	TEST SET-UP (BLOCK DIAGRAM OF CONFIGURATION)	17
5.3	MEASUREMENT EQUIPMENT USED:	18
5.4	FIELD STRENGTH CALCULATION	18
5.5	MEASUREMENT RESULT	19
6.	20 DB BAND WIDTH MEASUREMENT.....	27
6.1	MEASUREMENT PROCEDURE.....	27
6.2	TEST SET-UP (BLOCK DIAGRAM OF CONFIGURATION)	27
6.3	MEASUREMENT EQUIPMENT USED:	27
6.4	MEASUREMENT RESULTS:.....	27

1. General Information

1.1. Product Description

General:

Product Name	HOMESCREEN	
Brand Name	SECURIFI	
Model Name	Router + Automation Hub	
Model Difference	N/A	
Hardware Version	N/A	
Software Version	N/A	
Adhoc Mode	No	
DFS Mode	N/A	
TPC	No	
Operation Environment	Indoor used	
USB port	one provided for Data link	
Gigabit LAN	three provided	
Power Supply	12Vdc from AC/DC adapter	
	Adapter:	Model: MU12AB120100-A1

2.4GHz WLAN: 2TX/2RX SM-MIMO

5GHz WLAN: 1TX/1RX

Wi-Fi	Frequency Range (MHz)	Channels	Peak / Average Rated Power	Modulation Technology
802.11b	2412 – 2462(DTS)	11	20.46dBm (PK)	DSSS
802.11g	2412 – 2462(DTS)	11	27.07dBm (PK)	OFDM
802.11n (2.4G)	HT20 2412 – 2462(DTS)	11	27.76dBm (PK)	
	HT40 2422 – 2452(DTS)	7	28.52dBm (PK)	
802.11a	5180 – 5240(NII)	4	14.70dBm (AV)	
	5745 – 5825(NII)	5	15.82dBm (AV)	
802.11n(5G)	HT20 5180 – 5240(NII)	4	13.87dBm (AV)	
	HT20 5745 – 5825(NII)	5	13.77 dBm (AV)	
	HT40 5190 – 5230(NII)	3	13.72dBm (AV)	
	HT40 5755 – 5815(NII)	4	13.73dBm (AV)	
802.11ac	HT80 5210(NII)	1	13.68dBm (AV)	
	HT80 5775(NII)	1	13.64dBm (AV)	
Modulation type		CCK, DQPSK, DBPSK for DSSS 256QAM.64QAM. 16QAM, QPSK, BPSK for OFDM		
Antenna Designation		Fixed PIFA Antenna WiFi 2.4G Antenna 1 : 5.65 dBi WiFi 2.4G Antenna 2 : 5.56 dBi WiFi 5G Antenna : 4.68 dBi According to KDB662911 D01 SM-MIMO signals could be considered uncorrelated for purposes of directional gain computation. Directional gain = G_{ANT}		

The EUT is compliance with IEEE 802.11 a/b/g/n/ac Standard.

Zigbee

Modulation type	OQPSK
Frequency Range(MHz)	2405-2480MHz
Channel Number	16
Measured Power	PK: 92.82dBuV/m at 3 m
Antenna Designation:	PIFA Antenna /2.72 dBi

The report applies for 2.4GHz Zigbee mode.

Remark: The above DUT's information was declared by manufacturer. Please refer to the specifications or user's manual for more detailed description.

1.2. Related Submittal(s) / Grant (s)

This submittal(s) (test report) is intended for **FCC ID: AHLCA1** filing to comply with Section 15.249 of the FCC Part 15, Subpart C Rules.

1.3. Test Methodology

Both conducted and radiated testing were performed according to the procedures in ANSI C63.4 (2009) and RSS-Gen: 2010. Radiated testing was performed at an antenna to EUT distance 3 meters.

1.4. Test Facility

The measurement facilities used to collect the 3m Radiated Emission and AC power line conducted data are located on the address of **International Standards Laboratory** <Lung-Tan LAB> No. 120, Lane 180, San Ho Tsuen, Hsin Ho Rd., Lung-Tan Hsiang, Tao Yuan County 325, Taiwan which are constructed and calibrated to meet the FCC requirements in documents ANSI C63.4: 2009. FCC Registration Number is: TW1036.

1.5. Special Accessories

Not available for this EUT intended for grant.

1.6. Equipment Modifications

Not available for this EUT intended for grant.

2. System Test Configuration

2.1. EUT Configuration

The EUT configuration for testing is installed on RF field strength measurement to meet the Commissions requirement and operating in a manner which intends to maximize its emission characteristics in a continuous normal application.

2.2. EUT Exercise

The Transmitter was operated in the engineering operating mode. the Tx frequency was fixed at Lowest, Mid and highest channel which were for the purpose of the measurements.

2.3. Test Procedure

2.3.1 Conducted Emissions

The EUT is a placed on as turn table which is 0.8 m above ground plane. According to the requirements in Section 7 and 13 of ANSI C63.4-2009 and RSS-Gen: 2010. Conducted emissions from the EUT measured in the frequency range between 0.15 MHz and 30MHz using CISPR Quasi-Peak and Average detector mode.

2.3.2 Radiated Emissions

The EUT is a placed on as turn table which is 0.8 m above ground plane. The turn table shall rotate 360 degrees to determine the position of maximum emission level. EUT is set 3m away from the receiving antenna which varied from 1m to 4m to find out the highest emission. And also, each emission was to be maximized by changing the polarization of receiving antenna both horizontal and vertical. In order to find out the max. emission, the relative positions of this hand-held transmitter(EUT) was rotated through three orthogonal axes according to the requirements in Section 8 and 13 of ANSI C63.4-2009.

2.4. Limitation

(1) Conducted Emission

According to section 15.207(a) and RSS-Gen §7.2.2 Conducted Emission Limits is as following.

Frequency (MHz)	Conducted Limit (dBuV)	
	Quasi-Peak	Average
0.15 – 0.5	66 - 56	56 - 46
0.5 – 5	56	46
5 - 30	60	50

(2) Radiated Emission 15.249(a) and RSS-210 issue 8,§A2.9(a)

The field strength of emissions from intentional radiators operated within these frequency bands shall comply with the following.

Frequency (MHz)	Field strength of Fundamental	Field strength of Harmonics	Distance (m)
902 - 928	50 mV/m (94dBuV/m)	500 uV/m (54dBuV/m)	3
2400 – 2483.5	50 mV/m (94dBuV/m)	500 uV/m (54dBuV/m)	3
5725 – 5875	50 mV/m (94dBuV/m)	500 uV/m (54dBuV/m)	3

(3) Radiated Emission 15.249 (d) and RSS-210 issue 8, §A2.9(b)

Emission Radiated outside of the specified frequency bands, except for harmonics, shall be attenuated by at least 50dB below the level of the fundamental or to the general radiated emission limits in Section 15.209 and RSS-210 issue 8, §A2.9(a) as below, whichever is the lesser attenuation.

Frequency (MHz)	Field strength $\mu\text{V/m}$	Distance (m)	Field strength at 3m $\text{dB}\mu\text{V/m}$
1.705-30	30	30	69.54
30-88	100	3	40
88-216	150	3	43.5
216-960	200	3	46
Above 960	500	3	54

(4) Radiated Emission 15.249(e) and RSS-210 issue 8

For frequencies above 1000MHz, the above field strength limits are based on average limits. The peak field strength of any emission shall not exceed the maximum permitted average limits specified above by more than 20dB under any condition of modulation.

- Remark:
1. Emission level in $\text{dB}\mu\text{V/m} = 20 \log (\mu\text{V/m})$
 2. Measurement was performed at an antenna to the closed point of EUT distance of meters.
 3. Only spurious frequency is permitted to locate within the Restricted Bands specified in provision of § 15.205
 4. Emission spurious frequency which appearing within the Restricted Bands specified in provision of § 15.205, then the general radiated emission limits in § 15.209 apply.

2.5. Configuration of Tested System

Fig. 2-1 Configuration of Tested System

Zigbee mode

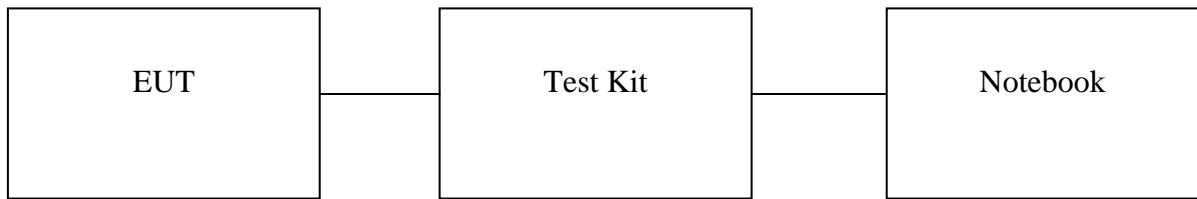

Table 2-2 Equipment Used in Tested System

Item	Equipment	Mfr/Brand	Model/ Type No.	Series No.	Data Cable	Power Cord
1	NoteBook	HP	440 G1	2CE40911GZ	N/A	No- Shielding
2	Test Kit	N/A	N/A	N/A	N/A	N/A

Note: All the above equipment/cables were placed in worse case positions to maximize emission signals during emission test.

Grounding: Grounding was in accordance with the manufacturer’s requirements and conditions for the intended use.

3. Summary of Test Results

FCC Rules	Description Of Test	Result
§15.207/	Conducted Emission	Compliant
§15.249(a)(d)(e)	Field Strength Measurement (TX and RX)	Compliant
§15.215(c)	20dB band width Measurement	Compliant

Description of test modes

The EUT has been tested under operating condition.

Test program used to control the EUT for staying in continuous transmitting and receive mode is programmed.

Zigbee mode:

Channel low (2405MHz)、 mid (2440MHz) and high (2480MHz) with highest data rate are chosen for full testing.

4. Conducted Emissions Test

4.1 Measurement Procedure:

1. The EUT was placed on a table which is 0.8m above ground plane.
2. Maximum procedure was performed on the six highest emissions to ensure EUT compliance.
3. Repeat above procedures until all frequency measured were complete.

4.2 Test SET-UP (Block Diagram of Configuration)

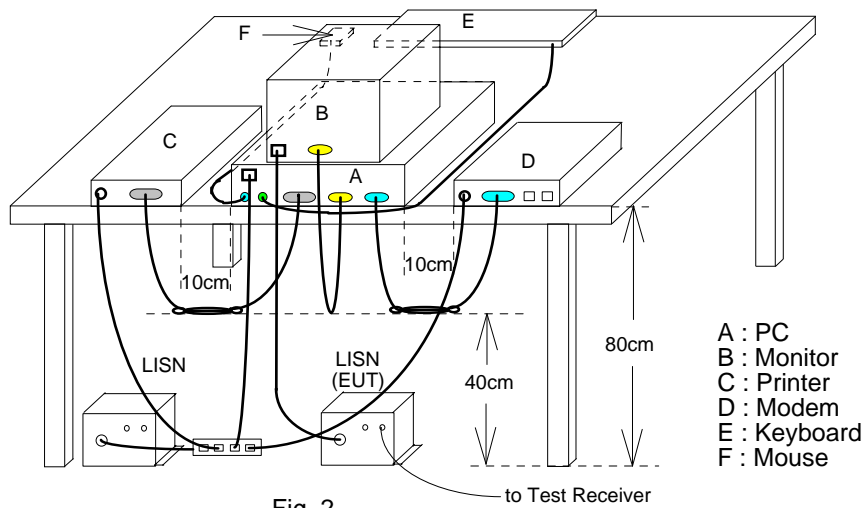

Fig. 2

4.3 Measurement Equipment Used:

Conducted Emission Test Site					
EQUIPMENT TYPE	MFR	MODEL NUMBER	SERIAL NUMBER	LAST CAL.	CAL DUE.
Conduction 04-1 Cable	WOKEN	CFD 300-NL	Conduction 04 -1	09/24/2014	09/23/2015
EMI Receiver 16	Rohde & Schwarz	ESCI	101221	05/08/2014	05/07/2015
LISN 18	ROHDE & SCHWARZ	ENV216	101424	03/13/2014	03/12/2015
LISN 19	ROHDE & SCHWARZ	ENV216	101425	03/13/2014	03/12/2015

4.4 Measurement Result:

Note: Refer to next page for measurement data and plots.

AC POWER LINE CONDUCTED EMISSION TEST DATA

Operation Mode:	Operation Mode	Test Date:	2014/10/22
Test By:	Dino		

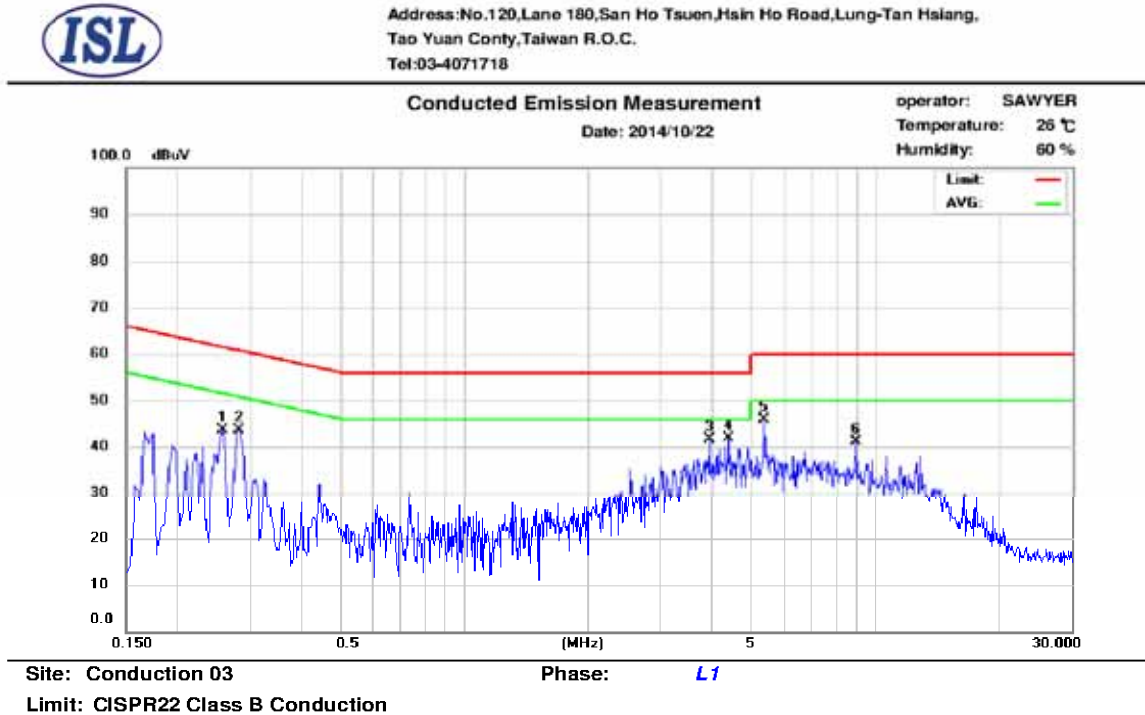

No.	Frequency (MHz)	Correct Factor (dB)	QP Emission (dBuV)	QP Limit (dBuV)	QP Margin (dB)	AVG Emission (dBuV)	AVG Limit (dBuV)	AVG Margin (dB)	Note
1	0.258	9.66	42.96	61.50	-18.54	33.71	51.50	-17.79	
2	0.282	9.66	41.64	60.76	-19.12	35.81	50.76	-14.95	
3	3.926	9.80	34.34	56.00	-21.66	23.93	46.00	-22.07	
4	4.406	9.81	35.03	56.00	-20.97	23.91	46.00	-22.09	
5	5.342	9.83	34.31	60.00	-25.69	23.70	50.00	-26.30	
6	8.930	9.90	30.61	60.00	-29.39	20.10	50.00	-29.90	



Address: No.120, Lane 180, San Ho Tsuen, Hsin Ho Road, Lung-Tan Hsiang,
Tao Yuan Conty, Taiwan R.O.C.
Tel: 03-4071718

Conducted Emission Measurement

Date: 2014/10/22

operator: SAWYER

Temperature: 26 °C

Humidity: 60 %

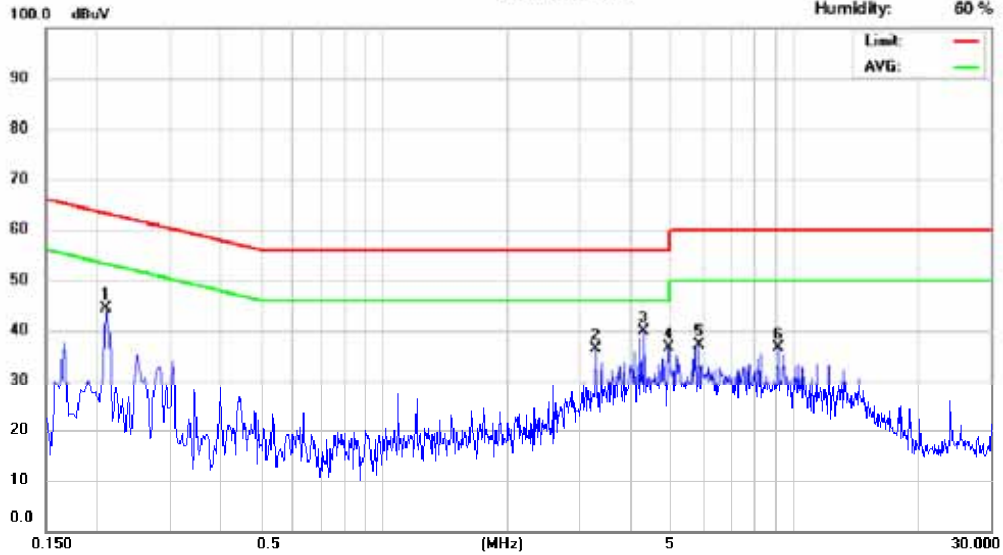

Site: Conduction 03

Phase: N

Limit: CISPR22 Class B Conduction

No.	Frequency (MHz)	Correct Factor (dB)	QP Emission (dBuV)	QP Limit (dBuV)	QP Margin (dB)	AVG Emission (dBuV)	AVG Limit (dBuV)	AVG Margin (dB)	Note
1	0.210	9.65	31.85	63.21	-31.36	12.13	53.21	-41.08	
2	3.290	9.77	25.48	56.00	-30.52	13.72	46.00	-32.28	
3	4.310	9.79	29.30	56.00	-26.70	18.03	46.00	-27.97	
4	4.926	9.81	29.09	56.00	-26.91	18.08	46.00	-27.92	
5	5.866	9.83	28.77	60.00	-31.23	17.81	50.00	-32.19	
6	9.110	9.90	25.82	60.00	-34.18	15.86	50.00	-34.14	

5. Radiated Emission Test (TX,RX)

5.1 Measurement Procedure

1. The EUT was placed on a turntable that is 0.8m above ground plane.
2. Maximum procedure was performed on the six highest emissions to ensure EUT compliance.
3. And also, each emission was to be maximized by changing the polarization of receiving antenna both horizontal and vertical.
4. Repeat above procedures until all frequency measured were complete.

5.2 Test SET-UP (Block Diagram of Configuration)

(A) Radiated Emission Test Set-Up, Frequency Below 1000MHz

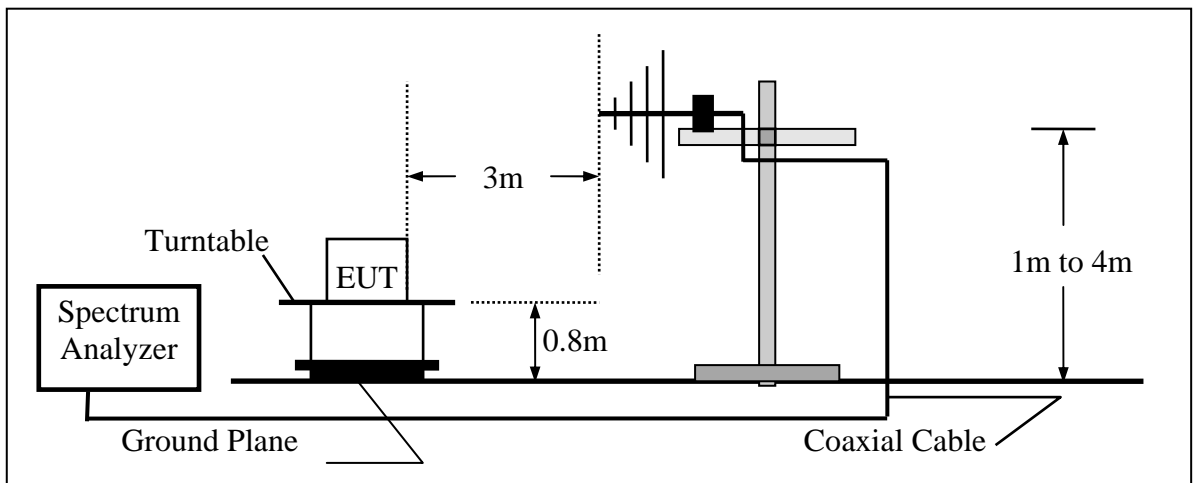

(B) Radiated Emission Test Set-UP Frequency Over 1 GHz

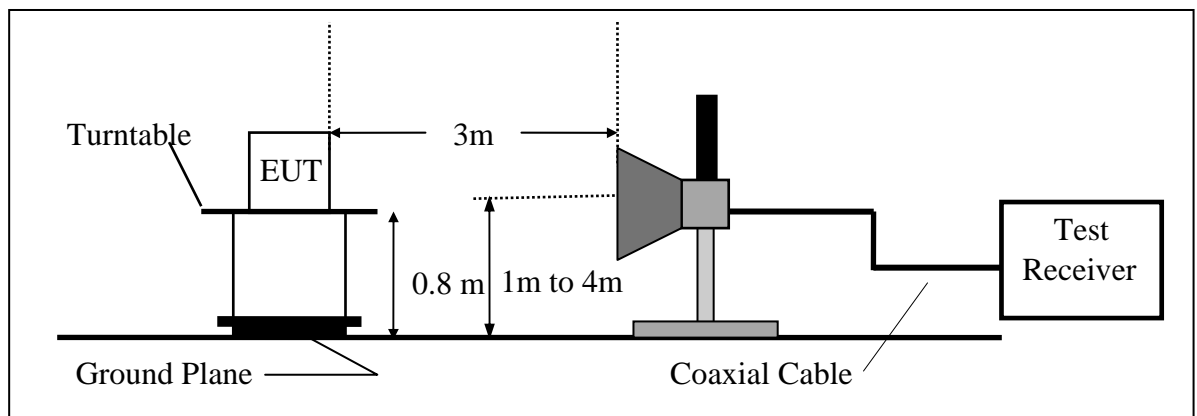

5.3 Measurement Equipment Used:

Chamber 14(966)					
EQUIPMENT TYPE	MFR	MODEL NUMBER	SERIAL NUMBER	LAST CAL.	CAL DUE.
Spectrum Analyzer 21(26.5GHz)	Agilent	N9010A	MY49060537	07/29/2014	07/28/2015
Spectrum Analyzer 20(6.5GHz)	Agilent	E4443A	MY48250315	05/26/2014	05/25/2015
Spectrum Analyzer 22(43GHz)	R&S	FSU43	100143	05/07/2014	05/06/2015
Loop Antenna9K-30M	A.H.SYSTEM	SAS-564	294	03/07/2013	03/06/2015
Bilog Antenna30-1G	Schaffner	CBL 6112B	2756	01/08/2014	01/07/2015
Horn antenna1-18G(06)	EMCO	3117	0006665	11/04/2014	11/03/2015
Horn antenna26-40G(05)	Com-power	AH-640	100A	01/09/2013	01/08/2015
Horn antenna18-26G(04)	Com-power	AH-826	081001	05/15/2013	05/14/2015
PREAMPLIFIER9-1000M	HP	8447D	NA	02/20/2014	02/19/2015
Preamplifier1-18G	MITEQ	AFS44-00101800-25-10P-44	1329256	07/30/2014	07/29/2015
Preamplifier1-26G	EM	EM01M26G	NA	02/20/2014	02/19/2015
PREAMPLIFIER26-40G	MITEQ	JS-26004000-27-5A	818471	05/08/2013	05/07/2015
Cable1-18G	HUBER SUHNER	Sucoflex 106	NA	02/17/2014	02/16/2015
Cable UP to 1G	HUBER SUHNER	RG 214/U	NA	10/17/2014	10/16/2015
SUCOFLEX 1GHZ-40GHZ CABLE	HUBER SUHNER	SUCOFLEX 102	27963/2&37421/2	10/03/2013	10/02/2015
2.4G Filter	Micro-Tronics	Brm50702	76	12/27/2013	12/26/2014
5G Filter	Micro-Tronics	Brm50716	005	12/27/2013	12/26/2014

5.4 Field Strength Calculation

The field strength is calculated by adding the Antenna Factor and Cable Factor and subtracting the Amplifier Gain and Duty Cycle Correction Factor(if any) from the measured reading. The basic equation with a sample calculation is as follows:

$$FS = RA + AF + CL - AG$$

Where	FS = Field Strength	CL = Cable Attenuation Factor (Cable Loss)
	RA = Reading Amplitude	AG = Amplifier Gain
	AF = Antenna Factor	

5.5 Measurement Result

5.5.1 Fundamental Emission Measurement Result

Test Date : 2014/10/22
 Temp : 25

Test By : Dino
 Hum. : 60%

Zigbee TX mode

CH Low:

No	Freq MHz	Reading dBuV	Factor dB	Level dBuV/m	Limit dBuV/m	Over Limit dB	Remark	Pol V/H
1	2405.37	103.85	-11.03	92.82	114.00	-21.18	Peak	VERTICAL
1	2405.36	103.03	-11.03	92.00	114.00	-22.00	Peak	HORIZONTAL

CH Mid:

No	Freq MHz	Reading dBuV	Factor dB	Level dBuV/m	Limit dBuV/m	Over Limit dB	Remark	Pol V/H
1	2439.43	103.46	-10.95	92.51	114.00	-21.49	Peak	VERTICAL
1	2440.33	102.93	-10.95	91.98	114.00	-22.02	Peak	HORIZONTAL

CH High:

No	Freq MHz	Reading dBuV	Factor dB	Level dBuV/m	Limit dBuV/m	Over Limit dB	Remark	Pol V/H
1	2479.41	102.97	-10.86	92.11	114.00	-21.89	Peak	VERTICAL
1	2480.40	101.40	-10.85	90.55	114.00	-23.45	Peak	HORIZONTAL

5.5.2 Radiated Spurious Emission Measurement Result (below 1GHz)

Operation Mode	Zigbee TX CH Low	Test Date	2014/10/22
Fundamental Frequency	2405 MHz	Test By	Dino
Temperature	25	Humidity	60 %

No	Freq MHz	Reading dBuV	Factor dB	Level dBuV/m	Limit dBuV/m	Over Limit dB	Remark	Pol V/H
1	144.46	46.13	-12.25	33.88	43.50	-9.62	Peak	VERTICAL
2	305.48	40.53	-10.99	29.54	46.00	-16.46	Peak	VERTICAL
3	456.80	40.93	-8.14	32.79	46.00	-13.21	Peak	VERTICAL
4	579.99	41.54	-6.18	35.36	46.00	-10.64	Peak	VERTICAL
5	629.46	37.04	-5.31	31.73	46.00	-14.27	Peak	VERTICAL
6	858.38	33.97	-1.62	32.35	46.00	-13.65	Peak	VERTICAL
1	53.28	42.44	-12.31	30.13	40.00	-9.87	Peak	HORIZONTAL
2	192.96	48.32	-14.61	33.71	43.50	-9.79	Peak	HORIZONTAL
3	360.77	41.08	-10.02	31.06	46.00	-14.94	Peak	HORIZONTAL
4	409.27	39.47	-9.06	30.41	46.00	-15.59	Peak	HORIZONTAL
5	634.31	40.07	-5.23	34.84	46.00	-11.16	Peak	HORIZONTAL
6	673.11	36.91	-4.67	32.24	46.00	-13.76	Peak	HORIZONTAL

Remark:

- 1 Measuring frequencies from the lowest internal frequency to the 10th of fundamental frequency
- 2 Field strength limits for frequency above 1000MHz are based on average limits. However, Peak mode field strength shall not exceed the average limits specified plus 20dB.
- 3 “F” denotes fundamental frequency; “H” denotes harmonics frequency. “S” denotes spurious frequency.
- 4 Measurement of data within this frequency range shown “ - ” in the table above means the reading of emissions are attenuated more than 20dB below the permissible limits or the field strength is too small to be measured.
- 5 Spectrum Peak mode IF bandwidth Setting : 1GHz- 26GHz, RBW= 1MHz, Sweep time= 200 ms., the VBW setting was 3 MHz.
- 6 Spectrum AV mode if bandwidth Setting : 1GHz- 26GHz, RBW= 1MHz, VBW= 10Hz, Sweep time= 200 ms.

Radiated Spurious Emission Measurement Result (below 1GHz)

Operation Mode	Zigbee TX CH Mid	Test Date	2014/10/22
Fundamental Frequency	2440 MHz	Test By	Dino
Temperature	25	Humidity	60 %

No	Freq MHz	Reading dBuV	Factor dB	Level dBuV/m	Limit dBuV/m	Over Limit dB	Remark	Pol V/H
1	144.46	46.05	-12.25	33.80	43.50	-9.70	Peak	VERTICAL
2	308.39	41.66	-10.94	30.72	46.00	-15.28	Peak	VERTICAL
3	456.80	41.02	-8.14	32.88	46.00	-13.12	Peak	VERTICAL
4	725.49	40.31	-3.59	36.72	46.00	-9.28	Peak	VERTICAL
5	878.75	36.18	-1.23	34.95	46.00	-11.05	Peak	VERTICAL
6	917.55	32.60	-0.49	32.11	46.00	-13.89	Peak	VERTICAL
1	53.28	43.18	-12.31	30.87	40.00	-9.13	Peak	HORIZONTAL
2	192.96	49.48	-14.61	34.87	43.50	-8.63	Peak	HORIZONTAL
3	360.77	41.14	-10.02	31.12	46.00	-14.88	Peak	HORIZONTAL
4	620.73	42.41	-5.41	37.00	46.00	-9.00	Peak	HORIZONTAL
5	634.31	43.96	-5.23	38.73	46.00	-7.27	Peak	HORIZONTAL
6	872.93	33.01	-1.35	31.66	46.00	-14.34	Peak	HORIZONTAL

Remark:

- 1 Measuring frequencies from the lowest internal frequency to the 10th of fundamental frequency
- 2 Field strength limits for frequency above 1000MHz are based on average limits. However, Peak mode field strength shall not exceed the average limits specified plus 20dB.
- 3 “F” denotes fundamental frequency; “H” denotes harmonics frequency. “S” denotes spurious frequency.
- 4 Measurement of data within this frequency range shown “ - ” in the table above means the reading of emissions are attenuated more than 20dB below the permissible limits or the field strength is too small to be measured.
- 5 Spectrum Peak mode IF bandwidth Setting : 1GHz- 26GHz, RBW= 1MHz, Sweep time= 200 ms., the VBW setting was 3 MHz.
- 6 Spectrum AV mode if bandwidth Setting : 1GHz- 26GHz, RBW= 1MHz, VBW= 10Hz, Sweep time= 200 ms.

Radiated Spurious Emission Measurement Result (below 1GHz)

Operation Mode	Zigbee TX CH High	Test Date	2014/10/22
Fundamental Frequency	2480 MHz	Test By	Dino
Temperature	25	Humidity	60 %

No	Freq MHz	Reading dBuV	Factor dB	Level dBuV/m	Limit dBuV/m	Over Limit dB	Remark	Pol V/H
1	144.46	46.05	-12.25	33.80	43.50	-9.70	Peak	VERTICAL
2	306.45	42.01	-10.98	31.03	46.00	-14.97	Peak	VERTICAL
3	456.80	40.81	-8.14	32.67	46.00	-13.33	Peak	VERTICAL
4	579.99	43.02	-6.18	36.84	46.00	-9.16	Peak	VERTICAL
5	867.11	34.14	-1.46	32.68	46.00	-13.32	Peak	VERTICAL
6	873.90	32.97	-1.33	31.64	46.00	-14.36	Peak	VERTICAL
1	55.22	42.72	-12.43	30.29	40.00	-9.71	Peak	HORIZONTAL
2	192.96	47.91	-14.61	33.30	43.50	-10.20	Peak	HORIZONTAL
3	579.99	41.00	-6.18	34.82	46.00	-11.18	Peak	HORIZONTAL
4	634.31	41.76	-5.23	36.53	46.00	-9.47	Peak	HORIZONTAL
5	676.99	43.38	-4.62	38.76	46.00	-7.24	Peak	HORIZONTAL
6	870.02	31.29	-1.40	29.89	46.00	-16.11	Peak	HORIZONTAL

Remark:

- 1 Measuring frequencies from the lowest internal frequency to the 10th of fundamental frequency
- 2 Field strength limits for frequency above 1000MHz are based on average limits. However, Peak mode field strength shall not exceed the average limits specified plus 20dB.
- 3 “F” denotes fundamental frequency; “H” denotes harmonics frequency. “S” denotes spurious frequency.
- 4 Measurement of data within this frequency range shown “ - ” in the table above means the reading of emissions are attenuated more than 20dB below the permissible limits or the field strength is too small to be measured.
- 5 Spectrum Peak mode IF bandwidth Setting : 1GHz- 26GHz, RBW= 1MHz, Sweep time= 200 ms., the VBW setting was 3 MHz.
- 6 Spectrum AV mode if bandwidth Setting : 1GHz- 26GHz, RBW= 1MHz, VBW= 10Hz, Sweep time= 200 ms.

Radiated Spurious Emission Measurement Result (above 1GHz)

Operation Mode : Zigbee TX CH Mid Test Date : 2014/10/22
 Fundamental Frequency : 2440 MHz Test By : Dino
 Temp : 25 Hum. : 60%

No	Freq MHz	Reading dBuV	Factor dB	Level dBuV/m	Limit dBuV/m	Over Limit dB	Remark	Pol V/H
1	2001.00	62.88	-12.05	50.83	74.00	-23.17	Peak	VERTICAL
2	3268.00	52.81	-8.04	44.77	74.00	-29.23	Peak	VERTICAL
3	4880.00	52.36	-1.61	50.75	74.00	-23.25	Peak	VERTICAL
4	7320.00	---						VERTICAL
5	9760.00	---						VERTICAL
6	12200.00	---						VERTICAL
1	2001.00	54.09	-12.05	42.04	74.00	-31.96	Peak	HORIZONTAL
2	3268.00	54.00	-8.04	45.96	74.00	-28.04	Peak	HORIZONTAL
3	4880.00	54.25	-1.61	52.64	74.00	-21.36	Peak	HORIZONTAL
4	7320.00	---						HORIZONTAL
5	9760.00	---						HORIZONTAL
6	12200.00	---						HORIZONTAL

Remark:

- 1 Measuring frequencies from the lowest internal frequency to the 10th of fundamental frequency
- 2 Field strength limits for frequency above 1000MHz are based on average limits. However, Peak mode field strength shall not exceed the average limits specified plus 20dB.
- 3 Measurement of data within this frequency range shown “ - ” in the table above means the reading of emissions are attenuated more than 20dB below the permissible limits or the field strength is too small to be measured.
- 4 Spectrum Peak mode IF bandwidth Setting : 1GHz- 26GHz, RBW= 1MHz, Sweep time= 200 ms., the VBW setting was 3 MHz.
- 5 Spectrum AV mode IF bandwidth Setting : 1GHz- 26GHz, RBW= 1MHz, Sweep time= 200 ms., the VBW setting was 10MHz.

Radiated Spurious Emission Measurement Result (above 1GHz)

Operation Mode : Zigbee TX CH High Test Date : 2014/06/25
 Fundamental Frequency : 2480 MHz Test By : Dino
 Temp : 25 Hum. : 60%

No	Freq MHz	Reading dBuV	Factor dB	Level dBuV/m	Limit dBuV/m	Over Limit dB	Remark	Pol V/H
1	1994.00	55.84	-12.09	43.75	74.00	-30.25	Peak	VERTICAL
2	3268.00	53.22	-8.04	45.18	74.00	-28.82	Peak	VERTICAL
3	4960.00	52.06	-1.30	50.76	74.00	-23.24	Peak	VERTICAL
4	7440.00	---						VERTICAL
5	9920.00	---						VERTICAL
6	12400.00	---						VERTICAL
1	2001.00	53.95	-12.05	41.90	74.00	-32.10	Peak	HORIZONTAL
2	3268.00	54.89	-8.04	46.85	74.00	-27.15	Peak	HORIZONTAL
3	4960.00	53.07	-1.30	51.77	74.00	-22.23	Peak	HORIZONTAL
4	7440.00	---						HORIZONTAL
5	9920.00	---						HORIZONTAL
6	12400.00	---						HORIZONTAL

Remark:

- 1 Measuring frequencies from the lowest internal frequency to the 10th of fundamental frequency
- 2 Field strength limits for frequency above 1000MHz are based on average limits. However, Peak mode field strength shall not exceed the average limits specified plus 20dB.
- 3 Measurement of data within this frequency range shown “ - ” in the table above means the reading of emissions are attenuated more than 20dB below the permissible limits or the field strength is too small to be measured.
- 4 Spectrum Peak mode IF bandwidth Setting : 1GHz- 26GHz, RBW= 1MHz, Sweep time= 200 ms., the VBW setting was 3 MHz.
- 5 Spectrum AV mode IF bandwidth Setting : 1GHz- 26GHz, RBW= 1MHz, Sweep time= 200 ms., the VBW setting was 10MHz.

Radiated Spurious Emission Measurement Result (Band Edge)

Operation Mode : Zigbee Band Edge Test Date :2014/10/22
 Temp./Hum. : 25 / : 60% Test By : Dino

CH Low

No	Freq MHz	Reading dBuV	Factor dB	Level dBuV/m	Limit dBuV/m	Over Limit dB	Remark	Pol V/H
1	2400.00	38.46	-11.05	27.41	54.00	-26.59	Average	VERTICAL
2	2400.00	68.35	-11.05	57.30	74.00	-16.70	Peak	VERTICAL
1	2400.00	36.90	-11.05	25.85	54.00	-28.15	Average	HORIZONTAL
2	2400.00	66.64	-11.05	55.59	74.00	-18.41	Peak	HORIZONTAL

CH High

No	Freq MHz	Reading dBuV	Factor dB	Level dBuV/m	Limit dBuV/m	Over Limit dB	Remark	Pol V/H
1	2483.50	46.70	-10.83	35.87	54.00	-18.13	Average	VERTICAL
2	2483.50	76.53	-10.83	65.70	74.00	-8.30	Peak	VERTICAL
1	2483.50	44.36	-10.83	33.53	54.00	-20.47	Average	HORIZONTAL
2	2483.50	74.66	-10.83	63.83	74.00	-10.17	Peak	HORIZONTAL

Remark:

- 1 Measuring frequencies from the lowest internal frequency to the 10th of fundamental frequency
- 2 Field strength limits for frequency above 1000MHz are based on average limits. However, Peak mode field strength shall not exceed the average limits specified plus 20dB.
- 3 Measurement of data within this frequency range shown “ - ” in the table above means the reading of emissions are attenuated more than 20dB below the permissible limits or the field strength is too small to be measured.
- 4 Spectrum Peak mode IF bandwidth Setting : 1GHz- 26GHz, RBW= 1MHz, Sweep time= 200 ms., the VBW setting was 3 MHz.
- 5 Spectrum AV mode IF bandwidth Setting : 1GHz- 26GHz, RBW= 1MHz, Sweep time= 200 ms., the VBW setting was 10MHz.

6. 20 dB Band Width Measurement

6.1 Measurement Procedure

1. The EUT was placed on a turn table which is 0.8m above ground plane.
2. Set ETU normal operating mode.
3. Set SPA Center Frequency = fundamental frequency, RBW = 100kHz, VBW = 300kHz, Span =500kHz.
4. Set SPA Max hold. Mark peak, -20dB.

6.2 Test SET-UP (Block Diagram of Configuration)

Same as 4.2 Radiated Emission Measurement.

6.3 Measurement Equipment Used:

Same as 4.2 Radiated Emission Measurement.

6.4 Measurement Results:

Zigbee:

2405 Channel = 2.650 M Hz

2440 Channel = 2.628 M Hz

2480 Channel = 2.644 M Hz

Refer to attached data chart.

20dB Band Width test Plot CH Low



CH Mid



CH High

