

Test System-Arrangement (Drawings)

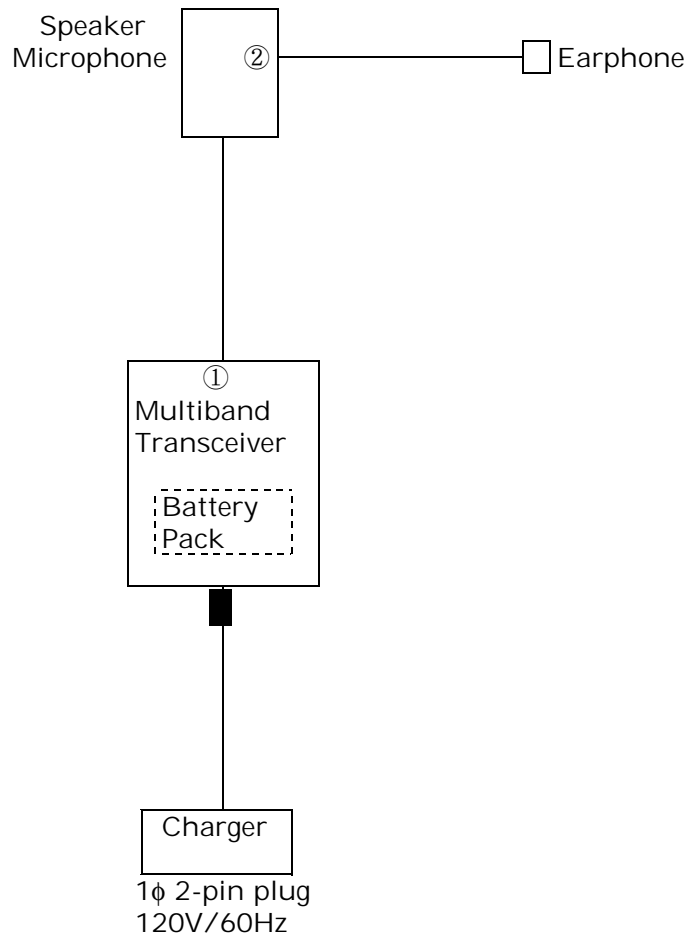

Note)

※ - No termination

① - SP/MIC

② - Earphone

■ - Ferrite Core

Preliminary Test and Test-setup(Drawings)

AC Powerline Conducted Emission 150 kHz - 30 MHz:

Measurement Procedure: IEEE 213(1987) & ANSI C63.4(1992)

The preliminary test was performed receiving over each band, and the worst result was reported as the final test.

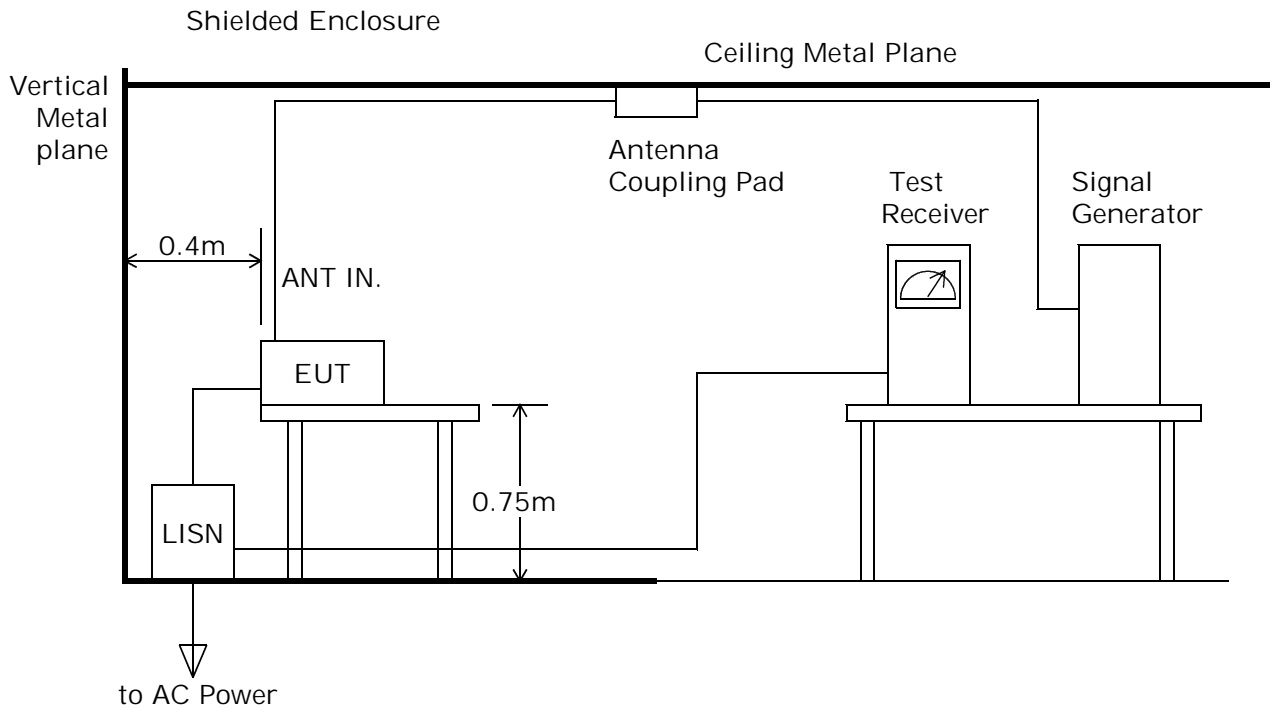

Electromagnetic Field Radiated Emission 30 MHz - 1000 MHz:

The preliminary test was performed according to the description of ANSI C63.4-1992 Sec.8.3.1.1 (Preliminary Radiated Emissions Tests) and Sec.6.2.1 (Tabletop Equipment Tests).

The preliminary test was carried out to investigate the frequency of the emission that has the highest amplitude relative to the limits within normal operating modes, cable positions, and a typical system configuration. In order to find out to the maximum emission, the preliminary test and a final test were performed in accordance with the following steps.

Step 1: One operation mode of the test system was setting.

Step 2: Using a test receiver and a test antenna probe, the significant frequency of the emission's circumstance from the test system were investigated. These data were recorded every one of 22 divided bands in the specified frequency band (30 MHz - 1000 MHz).

Step 3: Using a test receiver and a linearly polarized broadband antenna, the emission's circumstance from the test system was measured in according with ANSI C63.4-1992 Sec.8.3.1.2 (Final Radiated Emissions Tests) at each frequency which was found the higher emission referred to level vs. frequency on the list and which was measured by the resonant tuned dipole antenna. The maximum emission was found by changing the cable positions or cable manipulation under a typical system configuration.

Step 4: Return to step 1, if the other operation mode was possible to be setting.

Step 5: The worst result was reported arranging data of which was obtained and performed by one or plural operation modes as the final test.

At the worst point that has the highest amplitude relative to the limit the repeatability of the level was reconfirmed. The photographs of the tests system setup on the the worst point were taken and recorded.

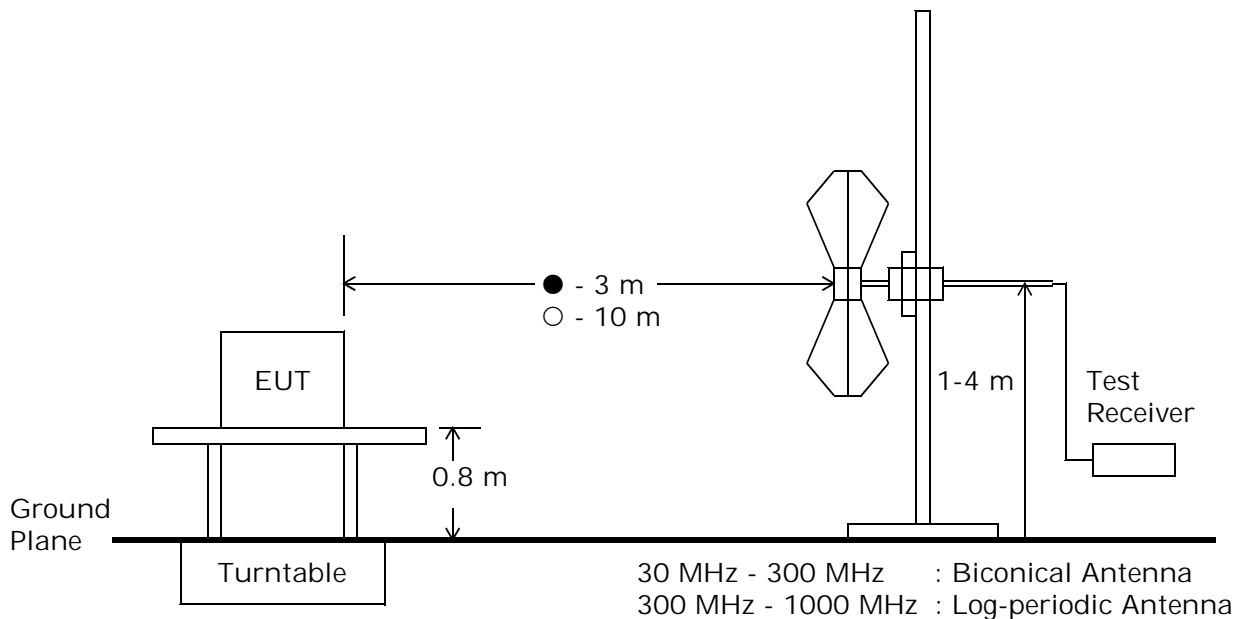

Electromagnetic Field Radiated Emission 1 GHz - 2.2 GHz:

The preliminary test was performed according to the description of ANSI C63.4-1992 Sec.8.3.1.1 (Preliminary Radiated Emissions Tests) and Sec.6.2.1 (Tabletop Equipment Tests).

The preliminary test was carried out to investigate the frequency of the emission that has the highest amplitude relative to the limits within normal operating modes, cable positions, and a typical system configuration. In order to find out to the maximum emission, the preliminary test and a final test were performed in accordance with the following steps.

Step 1: One operation mode of the test system was setting.

Step 2: In order to investigate the frequencies of maximum emissions, the horn antenna position was approached to the EUT and the significant frequency of the emission's circumstance from the test system were investigated. These data were recorded in the specified frequency band (1 GHz - 2.2 GHz).

Step 3: The emission's circumstance from the test system was measured in accordance with ANSI C63.4-1992, Sec.8.3.1.2 (Final Radiated Emissions Tests) at each frequency which was found higher emission referred to level vs. frequency on the list and which was measured in the specified distance using the horn antenna.

Step 4: Return to step 1, if the other operation mode was possible to be setting.

Step 5: The worst result was reported arranging data of which was obtained and performed by one or plural operation modes as the final test.

At the worst point that has the highest amplitude relative to the limit the repeatability of the level was reconfirmed. The photographs of the tests system setup on the worst point were taken and recorded.

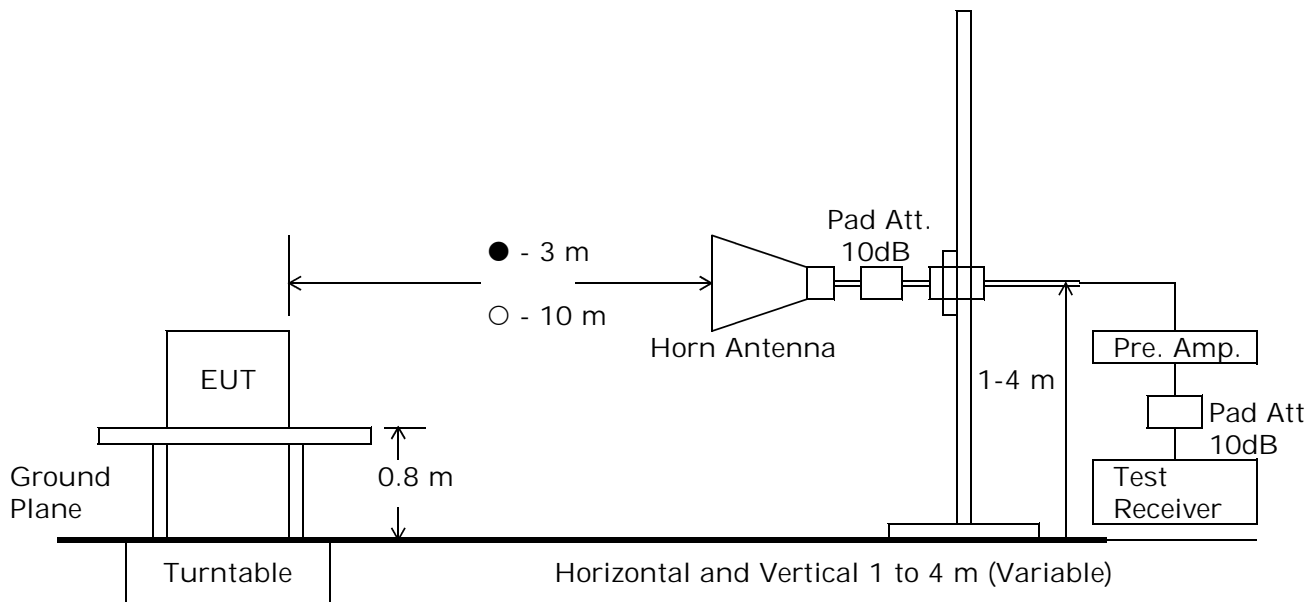

38dB Rejection Test (§15.121(b)):

The test(38dB Rejection Test) is carried out in accordance with procedure as follows.

1) Test system is composed as follows.

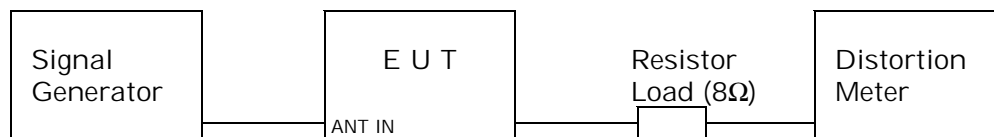

2) The setting frequencies of the signal generator were selected the bottom, the medium and the top frequency within each of the frequency bands allocated to the Cellular Radiotelephone Service in CFR 47 FCC Rules and Regulations Part 22 Subpart H.

For transmitter in Mobile : 824.040 MHz, 836.505 MHz, 848.970 MHz

For transmitter in Base : 869.040 MHz, 881.505 MHz, 893.970 MHz

The setting output of the signal generator was adjusted to a level 66dB(μ V). The setting frequency modulation was adjusted to an 1 kHz tone at 3 kHz deviation.

3) The EUT is capable of receiving 0.4950 MHz - 999.9900 MHz.

For each frequency in step 2), the band of the EUT was scanned all over the range by stepping up every 1 kHz. Then the squelch of the EUT was adjusted to a minimum threshold level. Whenever the scanning stopped, the detected frequency was noted.

4) The EUT was tuning to the detected frequency under signal generator was setting to the same condition as step 3). At first, The volume position of the EUT was adjusted as the audio nominal power is set to 50mW at 8 Ω .

The level of the signal generator(12dB SINAD level at the injected frequency) was adjusted as the distortion meter is set to produce a 12dB SINAD measurement (audio nominal power 50mW at 8 Ω , and 25% of distortion).

5) The EUT was tuning to the detected frequency under signal generator was setting to the same detected frequency. At first, The volume position of the EUT was adjusted as the audio nominal power is set to 50mW at 8 Ω .

The level of the signal generator(12dB SINAD level at the detected frequency) was adjusted as the distortion meter is set to produce a 12dB SINAD measurement (audio nominal power 50mW at 8 Ω , and 25% of distortion).

6) The rejection ratio, i.e. the difference between the 12dB SINAD levels at the injected frequency and the detected frequency, must be at least 38dB.

Test-Setup (Photographs) at worst case

Conducted Emission 150kHz - 30MHz:



Front View

Radiated Emission 30 MHz - 2.2 GHz

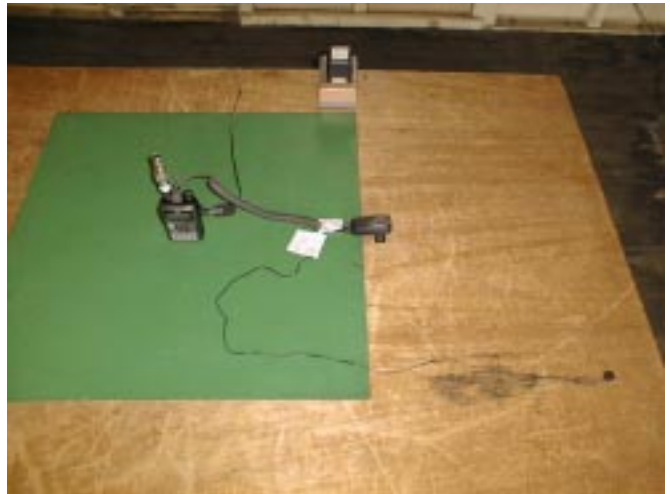

Front View



Side View



Rear View

Ferrite Core



Ferrite
Core

Charger