

MFA **M. Flom Associates, Inc. - Global Compliance Center**
3356 North San Marcos Place, Suite 107, Chandler, Arizona 85225-7176
www.mflom.com general@mflom.com (480) 926-3100, FAX: 926-3598

SUPPLEMENTARY TEST DATA

for

FCC ID: AFJIC-R8500

MODEL: IC-R8500

to

FEDERAL COMMUNICATIONS COMMISSION

Rule Part 15.121

DATE OF REPORT: February 1, 2000

ON THE BEHALF OF THE APPLICANT:

Icom Incorporated

AT THE REQUEST OF:

P.O. UPS 1/28/2000

Icom America, Inc.
2380 - 116th Ave. N. E.
P.O. C-90029
Bellevue, Washington 98009-9029

Attention of:

Masaaki Takahashi, Product Development Manager
m-takahashi@icomamerica.com
(800) 872-4266; (425) 454-8155; FAX: -1509

SUPERVISED BY:



Morton Flom, P. Eng.

TABLE OF CONTENTS

<u>RULE</u>	<u>DESCRIPTION</u>	<u>PAGE</u>
2.948	Description of Measurement Facilities	1
15.121(b)	Scanning Receiver	5

PAGE NO.

1 of 6.

Required information per ISO/IEC Guide 25-1990, paragraph 13.2:

- a) TEST REPORT
- b) Laboratory: M. Flom Associates, Inc.
 (FCC: 31040/SIT) 3356 N. San Marcos Place, Suite 107
 (Canada: IC 2044) Chandler, AZ 85225
- c) Report Number: d0020001
- d) Client: Icom America, Inc.
 2380 - 116th Ave. N. E.
 P.O. C-90029
 Bellevue, Washington 98009-9029
- e) Identification: IC-R8500
 FCC ID: AFJIC-R8500
 Description: Multi Band Amateur Receiver
- f) EUT Condition: Not required unless specified in individual tests.
- g) Report Date: February 1, 2000
 EUT Received: January 28, 2000
- h, j, k): As indicated in individual tests.
- i) Sampling method: No sampling procedure used.
- l) Uncertainty: In accordance with MFA internal quality manual.
- m) Supervised by: 
 Morton Flom, P. Eng.
- n) Results: The results presented in this report relate only to the item tested.
- o) Reproduction: This report must not be reproduced, except in full, without written permission from this laboratory.

M. Flom Associates, Inc. is accredited by the American Association for Laboratory Association (A2LA) as shown in the scope below.



THE AMERICAN ASSOCIATION FOR LABORATORY ACCREDITATION

ACCREDITED LABORATORY

A2LA has accredited

M. FLOM ASSOCIATES, INC.
Chandler, AZ

for technical competence in the field of

Electrical (EMC) Testing

The accreditation covers the specific tests and types of tests listed on the agreed scope of accreditation. This laboratory meets the requirements of ISO/IEC Guide 25-1990 "General Requirements for the Competence of Calibration and Testing Laboratories" (equivalent to relevant requirements of the ISO 9000 series of standards) and any additional program requirements in the identified field of testing.

Presented this 24th day of November, 1998.



Peter Almy
President
For the Accreditation Council
Certificate Number 1008.01
Valid to December 31, 2000

For tests or types of tests to which this accreditation applies, please refer to the laboratory's Electrical (EMC) Scope of Accreditation



American Association for Laboratory Accreditation

SCOPE OF ACCREDITATION TO ISO/IEC GUIDE 25-1990 AND EN 45001

M. FLOM ASSOCIATES, INC.
Electronic Testing Laboratory
3356 North San Marcos Place, Suite 107
Chandler, AZ 85224-1571
Morton Flom Phone: 602 926 3100

ELECTRICAL (EMC)

Valid to: December 31, 2000 Certificate Number: 1008-01

In recognition of the successful completion of the A2LA evaluation process, accreditation is granted to this laboratory to perform the following electromagnetic compatibility tests:

Tests	Standard(s)
RF Emissions	FCC Part 15 (Subparts B and C) using ANSI C63.4-1992; CISPR 11; CISPR 13; CISPR 14; CISPR 22; EN 55011; EN 55013; EN 55014; EN 55022; EN 50081-1; EN 50081-2; FCC Part 18; ICES-003; AS/NZS 1044; AS/NZS 1053; AS/NZS 3548; AS/NZS 4251.1
RF Immunity	EN 50082-1; EN 50082-2; AS/NZS 4251.1
Radiated Susceptibility	EN 61000-4-3; ENV 50140; ENV 50204; IEC 1000-4-3; IEC 801-3
ESD	EN 61000-4-2; IEC 1000-4-2; IEC 801-2
EFT	EN 61000-4-4; IEC 1000-4-4; IEC 801-4
Surge	EN 61000-4-5; ENV 50142; IEC 1000-4-5; IEC 801-5
47 CFR (FCC)	2, 21, 22, 23, 24, 74, 80, 87, 90, 95, 97

Peter Almy

5301 Buckeystown Pike, Suite 350 • Frederick, MD 21704-8307 • Phone: 301 644 3200 • Fax: 301 662 2974

"This laboratory is accredited by the American Association for Laboratory Accreditation (A2LA) and the results shown in this report have been determined in accordance with the laboratory's terms of accreditation unless stated otherwise in the report."

Should this report contain any data for tests for which we are not accredited, or which have been undertaken by a subcontractor that is not A2LA accredited, such data would not covered by this laboratory's A2LA accreditation.

PAGE NO.

3 of 6.

PURPOSE OF APPLICATION:

The purpose of this application was for the applicant to continue to show compliance with the new scanning receiver requirements of 47 CFR 15.121. Our examination of the original application comparing the photographs and parts list on file with the newest production sample did not show any significant modifications in electrical or mechanical construction. In our opinion, the equipment is identical to the original filing.

PAGE NO.

4 of 6.

GENERAL INFORMATION

Part 2.948:

(a)(b) DESCRIPTION OF MEASUREMENT FACILITIES:
 FILE: 31040/SIT

A description of the measurement facilities was filed with the Commission and was found to be in compliance with the requirements of Section 2.948, by letter dated March 3, 1997. All pertinent changes will be reported to the Commission by up-date prior to March 2000.

NAME AND ADDRESS OF APPLICANT:

Icom Incorporated
 1-6-19 Kamikurazukuri
 Hirano-ku
 Osaka, Japan 547

2.911:
 2.1033(b)(6)

TECHNICAL REPORTMANUFACTURER:

Icom Incorporated
 6-9-16 Kamihigashi
 Hirano-Ku
 Osaka, Japan 547

TRADE NAME:

Icom

FCC ID:

AFJIC-R8500

MODEL NO:

IC-R8500

15.31: MEASUREMENT STANDARD & PROCEDURE:

- ___ IEEE STANDARD 187 WAS USED AS A GUIDE.
 ___ FCC MEASUREMENT PROCEDURE MP-1
 x ANSI 63.4 (1992) "Methods of measurement of radio-noise emissions from low-voltage electrical and
 ___ electronic equipment in the range of 9 kHz to 40 GHz."

PAGE NO. 5 of 6.

NAME OF TEST: Scanning Receivers and Frequency Converters Used With Scanning Receivers

SPECIFICATION: FCC: 47 CFR 15.121(b)

GUIDE: See Measurement Procedure Below

TEST CONDITIONS: S. T. & H.

TEST EQUIPMENT: As per attached page

GUIDE: 47 CFR 15.121(b): Except as provided in paragraph (c) of this section, scanning receivers shall reject any signals from Cellular Radiotelephone Service frequency bands that are 38 dB or higher based upon a 12 dB SINAD measurement, which is considered the threshold where a signal can be clearly discerned from any interference that may be present.

WARNING: MODIFICATION OF THIS DEVICE TO RECEIVE CELLULAR RADIOTELEPHONE SERVICE SIGNALS IS PROHIBITED UNDER FCC RULES AND FEDERAL LAW.

MEASUREMENT PROCEDURE

1. A search for all potential spurious responses was begun by setting a signal generator at a level of -47 dBm to each of three frequencies in the subscriber transmit and base transmit bands.
2. The EUT was then set to scan across it's entire receive band. The most sensitive of each spurious response was noted.
3. The equipment was connected as illustrated. A second radio frequency signal generator (unwanted signal source) was connected to the appropriate matching network.
4. In absence of the unwanted signal, the standard input signal was applied to the combining network. Its level was varied to obtain reference sensitivity. This level is P_{REF} .
5. The level of wanted input signal was increased by 3dB.
6. A high-level unwanted input signal, modulated with 400 Hz at 60% of the maximum permissible frequency deviation was connected to the combining network.
7. The unwanted signal frequency was varied over a range from 824-849 and 869-894 MHz, to search for degradation of the SINAD. When a response was found, the frequency of the unwanted signal was adjusted to maximize the degradation.
8. At the frequency of each spurious response the level of unwanted input signal was varied until the standard SINAD value obtained. The frequency of the unwanted signal and its level was recorded as P_{SPUR} .
9. Calculate the spurious response rejection for each frequency concerned as follows:

$$\text{Spurious Response Rejection} = P_{SPUR} - P_{REF}$$

SCANNING RECEIVER:

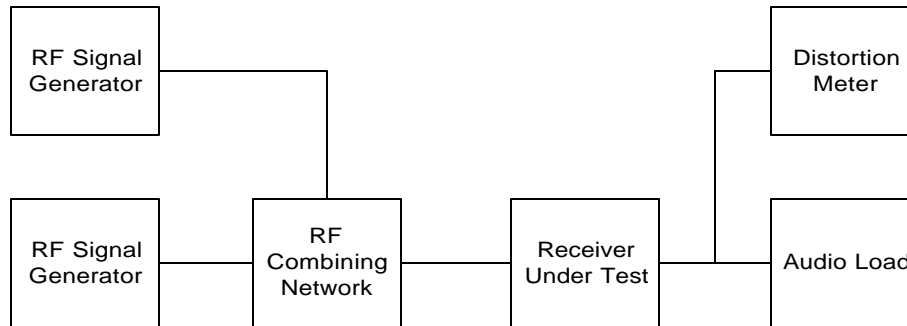

TEST RESULTS:

DISPLAYED FREQUENCY	IMAGE FREQUENCY	P _{REF} (dBm)	P _{SPUR} (dBm)	REJECTION (dB)
0.1 MHz-29.999 MHz	*	*		
45.0 MHz	824.0	-103	-2	-101
80.0 MHz	858.698	-109	-2	-107
115.0 MHz	893.699	-101	-2	-99
558.0 MHz	824.699	-104	-1	-103
592.25 MHz	585.948	-102	-2	-100
626.5 MHz	893.198	-105	+3	-102

***NOTE:** No spurious responses detectable within these frequency ranges.

SUPERVISED BY:

Morton Flom, P. Eng.