

ENGINEERING TEST REPORT

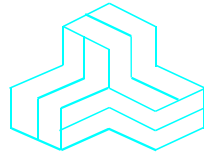

VHF-FM Handheld Transceiver
Model No.: IC-F3GT-2 and IC-F3GS-2
FCC ID: AFJIC-F3G-2

Applicant: **Icom Incorporated**
1-1-32, Kamiminami
Hirano-Ku, Osaka
Japan, 547-0003

Tested in Accordance With

Federal Communications Commission (FCC)
CFR 47, PARTS 2, 22, 74 and 90 (Subpart I)

UltraTech's File No.: ICOM27-FTX

This Test report is Issued under the Authority of
Tri M. Luu, Professional Engineer,
Vice President of Engineering
UltraTech Group of Labs

Date:



Report Prepared by: Dan Huynh

Tested by: Hung Trinh, RFI/EMI Technician
Wayne Wu, RFI/EMI Technician

Issued Date: June 25, 2001

Test Dates: May 26 – 31, 2001

The results in this Test Report apply only to the sample(s) tested, and the sample tested is randomly selected.

UltraTech

3000 Bristol Circle, Oakville, Ontario, Canada, L6H 6G4
Telephone (905) 829-1570 Facsimile (905) 829-8050

Website: www.ultratech-labs.com Email: vhk.ultratech@sympatico.ca

TABLE OF CONTENTS

EXHIBIT 1.	SUBMITTAL CHECK LIST	1
EXHIBIT 2.	INTRODUCTION	2
2.1.	SCOPE	2
2.2.	RELATED SUBMITTAL(S)/GRANT(S)	2
2.3.	NORMATIVE REFERENCES	2
EXHIBIT 3.	PERFORMANCE ASSESSMENT	3
3.1.	CLIENT INFORMATION	3
3.2.	EQUIPMENT UNDER TEST (EUT) INFORMATION	3
3.3.	EUT'S TECHNICAL SPECIFICATIONS	4
3.4.	LIST OF EUT'S PORTS	5
EXHIBIT 4.	EUT OPERATING CONDITIONS AND CONFIGURATIONS DURING TESTS	6
4.1.	CLIMATE TEST CONDITIONS.....	6
4.2.	OPERATIONAL TEST CONDITIONS & ARRANGEMENT FOR TEST SIGNALS.....	6
EXHIBIT 5.	SUMMARY OF TEST RESULTS	7
5.1.	LOCATION OF TESTS	7
5.2.	APPLICABILITY & SUMMARY OF EMC EMISSION TEST RESULTS	7
5.3.	MODIFICATIONS INCORPORATED IN THE EUT FOR COMPLIANCE PURPOSES	7
EXHIBIT 6.	MEASUREMENTS, EXAMINATIONS & TEST DATA FOR EMC EMISSIONS	8
6.1.	TEST PROCEDURES	8
6.2.	MEASUREMENT UNCERTAINTIES	8
6.3.	MEASUREMENT EQUIPMENT USED	8
6.4.	ESSENTIAL/PRIMARY FUNCTIONS AS DECLARED BY THE MANUFACTURER.....	8
6.5.	RF POWER OUTPUT @ FCC 2.1046 & 90.205	9
6.5.1.	<i>Limits @ FCC 90.205</i>	9
6.5.2.	<i>Method of Measurements</i>	9
6.5.3.	<i>Test Equipment List</i>	9
6.5.4.	<i>Test Arrangement</i>	9
6.5.5.	<i>Test Data</i>	10
6.6.	RF EXPOSURE REQUIREMENTS @ 2.1093	11
6.7.	EMISSION MASK @ FCC 2.1049, 90.209 & 90.210.....	12
6.7.1.	<i>Limits @ FCC 90.209 & 90.210</i>	12
6.7.2.	<i>Method of Measurements</i>	12
6.7.3.	<i>Test Equipment List</i>	12
6.7.4.	<i>Test Arrangement</i>	12
6.7.5.	<i>Test Data</i>	12
6.8.	TRANSMITTER ANTENNA POWER SPURIOUS/HARMONIC CONDUCTED EMISSIONS @ FCC 90.210.....	13
6.8.1.	<i>Limits @ 90.210</i>	13
6.8.2.	<i>Method of Measurements</i>	13
6.8.3.	<i>Test Equipment List</i>	13

ULTRATECH GROUP OF LABS

3000 Bristol Circle, Oakville, Ontario, Canada L6H 6G4
Tel. #: 905-829-1570, Fax. #: 905-829-8050, Email: vhk.ultratech@sympatico.ca, Website: <http://www.ultratech-labs.com>

File #: ICOM27-FTX
June 25, 2001

- Assessed by ITI (UK) Competent Body, NVLAP (USA) Accreditation Body & ACA/AUSTEL (Australia), VCCI (Japan)
- Accredited by Industry Canada (Canada) under ACC-LAB (Europe/Canada MRA and APEC/Canada MRA)
- Recognized/Listed by FCC (USA)
- All test results contained in this engineering test report are traceable to National Institute of Standards and Technology (NIST)

6.8.4.	Test Arrangement	13
6.8.5.	Test Data.....	14
6.9.	TRANSMITTER SPURIOUS/HARMONIC RADIATED EMISSIONS @ FCC 90.210.....	16
6.9.1.	Limits @ FCC 90.210.....	16
6.9.2.	Method of Measurements.....	16
6.9.3.	Test Equipment List	16
6.9.4.	Test Arrangement	17
6.9.5.	Test Data.....	18
6.10.	TRANSIENT FREQUENCY BEHAVIOR @ 90.214	24
6.10.1.	Limits	24
6.10.2.	Method of Measurements.....	24
6.10.3.	Test Equipment List	25
6.10.4.	Test Arrangement	25
6.10.5.	Test Data.....	26
EXHIBIT 7.	MEASUREMENT UNCERTAINTY.....	27
7.1.	RADIATED EMISSION MEASUREMENT UNCERTAINTY	27
EXHIBIT 8.	MEASUREMENT METHODS.....	28
8.1.	EMISSION MASK	28
8.2.	SPURIOUS EMISSIONS (CONDUCTED)	28
8.3.	SPURIOUS EMISSIONS (RADIATED).....	29
8.4.	TRANSIENT FREQUENCY BEHAVIOR.....	31

ULTRATECH GROUP OF LABS

3000 Bristol Circle, Oakville, Ontario, Canada L6H 6G4
Tel. #: 905-829-1570, Fax. #: 905-829-8050, Email: vhk.ultratech@sympatico.ca, Website: <http://www.ultratech-labs.com>

File #: ICOM27-FTX
June 25, 2001

- Assessed by ITI (UK) Competent Body, NVLAP (USA) Accreditation Body & ACA/AUSTEL (Australia), VCCI (Japan)
- Accredited by Industry Canada (Canada) under ACC-LAB (Europe/Canada MRA and APEC/Canada MRA)
- Recognized/Listed by FCC (USA)
- All test results contained in this engineering test report are traceable to National Institute of Standards and Technology (NIST)

EXHIBIT 1. SUBMITTAL CHECK LIST

Annex No.	Exhibit Type	Description of Contents	Quality Check (OK)
--	Test Report	<ul style="list-style-type: none"> • Exhibit 1: Submittal check lists • Exhibit 2: Introduction • Exhibit 3: Performance Assessment • Exhibit 4: EUT Operation and Configuration during Tests • Exhibit 5: Summary of test Results • Exhibit 6: Measurement Data • Exhibit 7: Measurement Uncertainty • Exhibit 8: Measurement Methods 	OK
1	Test Data Plots	<ul style="list-style-type: none"> • Emission Mask B (Plots # 1 to 6) • Spurious Emissions at Antenna Terminals (Plots # 7 to 18) • Transient Frequency Behavior (Plots # 19 to 22) 	OK
2	Test Setup Photos	Radiated Emission Test Setup Photos	OK
3	Cover Letters	<ul style="list-style-type: none"> • Letter from Ultratech for Certification Request • Letter from the Applicant to appoint Ultratech to act as an agent 	OK
4	RF Exposure Info	SAR Test Report	OK
5	Users Manual	Amendment	OK

ULTRATECH GROUP OF LABS

3000 Bristol Circle, Oakville, Ontario, Canada L6H 6G4
 Tel. #: 905-829-1570, Fax. #: 905-829-8050, Email: yhk.ultratech@sympatico.ca, Website: <http://www.ultratech-labs.com>

File #: ICOM27-FTX
 June 25, 2001

- Assessed by ITI (UK) Competent Body, NVLAP (USA) Accreditation Body & ACA/AUSTEL (Australia), VCCI (Japan)
- Accredited by Industry Canada (Canada) under ACC-LAB (Europe/Canada MRA and APEC/Canada MRA)
- Recognized/Listed by FCC (USA)
- All test results contained in this engineering test report are traceable to National Institute of Standards and Technology (NIST)

EXHIBIT 2. INTRODUCTION

2.1. SCOPE

Reference:	FCC Parts 2, 22, 74 and 90
Title:	Telecommunication - Code of Federal Regulations, CFR 47, Parts 2, 22, 74 & 90
Purpose of Test:	To gain FCC Certification Authorization for Radio operating in the frequency band 146-174 MHz (12.5 kHz and 25 kHz Channel Spacings).
Test Procedures:	Both conducted and radiated emissions measurements were conducted in accordance with American National Standards Institute ANSI C63.4 - American National Standard for Methods of Measurement of Radio-Noise Emissions from Low-Voltage Electrical and Electronic Equipment in the Range of 9 kHz to 40 GHz.

2.2. RELATED SUBMITTAL(S)/GRANT(S)

None

2.3. NORMATIVE REFERENCES

Publication	Year	Title
FCC CFR Parts 0-19, 80-End	1998	Code of Federal Regulations – Telecommunication
ANSI C63.4	1992	American National Standard for Methods of Measurement of Radio-Noise Emissions from Low-Voltage Electrical and Electronic Equipment in the Range of 9 kHz to 40 GHz
CISPR 22 & EN 55022	1997 1998	Limits and Methods of Measurements of Radio Disturbance Characteristics of Information Technology Equipment
CISPR 16-1		Specification for Radio Disturbance and Immunity measuring apparatus and methods

ULTRATECH GROUP OF LABS

3000 Bristol Circle, Oakville, Ontario, Canada L6H 6G4
Tel. #: 905-829-1570, Fax. #: 905-829-8050, Email: yhk.ultratech@sympatico.ca, Website: <http://www.ultratech-labs.com>

File #: ICOM27-FTX
June 25, 2001

- Assessed by ITI (UK) Competent Body, NVLAP (USA) Accreditation Body & ACA/AUSTEL (Australia), VCCI (Japan)
- Accredited by Industry Canada (Canada) under ACC-LAB (Europe/Canada MRA and APEC/Canada MRA)
- Recognized/Listed by FCC (USA)
- All test results contained in this engineering test report are traceable to National Institute of Standards and Technology (NIST)

EXHIBIT 3. PERFORMANCE ASSESSMENT

3.1. CLIENT INFORMATION

APPLICANT	
Name:	Icom Incorporated
Address:	1-1-32, Kamiminami Hirano-ku, Oaska Japan, 547-0003
Contact Person:	Mr. Takashi Aoki Phone #: +81-66-793-5302 Fax #: +81-66-793-0013 Email Address: export@icom.co.jp

MANUFACTURER	
Name:	Icom Incorporated
Address:	1-1-32, Kamiminami Hirano-ku, Oaska Japan, 547-0003
Contact Person:	Mr. Takashi Aoki Phone #: +81-66-793-5302 Fax #: # +81-66-793-0013 Email Address: export@icom.co.jp

3.2. EQUIPMENT UNDER TEST (EUT) INFORMATION

The following information (with the exception of the Date of Receipt) has been supplied by the applicant.

Brand Name:	Icom Incorporated
Product Name:	VHF-FM Handheld Transceiver
Model Name or Number:	IC-F3GT-2 and IC-F3GS-2
Serial Number:	Test Sample
Type of Equipment:	Licensed Non-broadcast Radio Communication Equipment
External Power Supply:	N/A
Transmitting/Receiving Antenna Type:	Non-integral
Primary User Functions of EUT:	Land Mobile

ULTRATECH GROUP OF LABS

3000 Bristol Circle, Oakville, Ontario, Canada L6H 6G4
Tel. #: 905-829-1570, Fax. #: 905-829-8050, Email: yhk.ultratech@sympatico.ca, Website: <http://www.ultratech-labs.com>

File #: ICOM27-FTX
June 25, 2001

- Assessed by ITI (UK) Competent Body, NVLAP (USA) Accreditation Body & ACA/AUSTEL (Australia), VCCI (Japan)
- Accredited by Industry Canada (Canada) under ACC-LAB (Europe/Canada MRA and APEC/Canada MRA)
- Recognized/Listed by FCC (USA)
- All test results contained in this engineering test report are traceable to National Institute of Standards and Technology (NIST)

3.3. EUT'S TECHNICAL SPECIFICATIONS

TRANSMITTER	
Equipment Type:	<input checked="" type="checkbox"/> Portable <input type="checkbox"/> Mobile <input type="checkbox"/> Base Station (fixed use)
Intended Operating Environment:	<input checked="" type="checkbox"/> Commercial <input checked="" type="checkbox"/> Light Industry & Heavy Industry
Power Supply Requirement:	7.2 Vdc (Icom Ni-Cd battery pack)
RF Output Power Rating:	1 to 5 Watts (Switchable)
Operating Frequency Range:	146 – 174 MHz
RF Output Impedance:	50 Ohms
Channel Spacing:	12.5 and 25 kHz
Frequency Tolerance	2.5ppm
Emission Designation*:	11K0F3E and 16K0F3E
Digital Oscillator Frequencies:	9.2 MHz
Radio Oscillator Frequencies:	15.3 MHz
Antenna Connector Type:	J connector
Antenna Description:	Manufacturer: Icom Type: ¼ wave whip antenna Model: FA-SC55V Frequency Range: 146-174MHz In/Out Impedance: 50 Ohms Gain: Less than 0dB

* For an average case of commercial telephony, the Necessary Bandwidth is calculated as follows:

For FM Voice Modulation:

Channel Spacing = 12.5 KHz, D = 2.5 KHz max., K = 1, M = 3 KHz

$$B_n = 2M + 2DK = 2(3) + 2(2.5)(1) = \mathbf{11\ KHz}$$

Emission Designation: 11K0F3E

Channel Spacing = 12.5 KHz, D = 5 KHz max., K = 1, M = 3 KHz

$$B_n = 2M + 2DK = 2(3) + 2(5)(1) = \mathbf{16\ KHz}$$

Emission Designation: 16K0F3E

ULTRATECH GROUP OF LABS

3000 Bristol Circle, Oakville, Ontario, Canada L6H 6G4
 Tel. #: 905-829-1570, Fax. #: 905-829-8050, Email: yhk.ultratech@sympatico.ca, Website: <http://www.ultratech-labs.com>

File #: ICOM27-FTX
 June 25, 2001

- Assessed by ITI (UK) Competent Body, NVLAP (USA) Accreditation Body & ACA/AUSTEL (Australia), VCCI (Japan)
- Accredited by Industry Canada (Canada) under ACC-LAB (Europe/Canada MRA and APEC/Canada MRA)
- Recognized/Listed by FCC (USA)
- All test results contained in this engineering test report are traceable to National Institute of Standards and Technology (NIST)

3.4. LIST OF EUT'S PORTS

Port Number	EUT's Port Description	Number of Identical Ports	Connector Type	Cable Type (Shielded/Non-shielded)
1	Antenna Connector	1	J Connector	N/A
2	SP/MIC	1	Speaker /Microphone Jack	Shielded

NOTES:

- (1) *Ports of the EUT which in normal operation were connected to ancillary equipment through interconnecting cables via a representative interconnecting cable to simulate the input/output characteristics. RF input/output was correctly terminated to the 50 Ω RF Load.*
- (2) *Ports, which are not connected to cables during normal intended operation (for factory/technical services uses only): None.*

ULTRATECH GROUP OF LABS

3000 Bristol Circle, Oakville, Ontario, Canada L6H 6G4
Tel. #: 905-829-1570, Fax. #: 905-829-8050, Email: yhk.ultratech@sympatico.ca, Website: <http://www.ultratech-labs.com>

File #: ICOM27-FTX
June 25, 2001

- Assessed by ITI (UK) Competent Body, NVLAP (USA) Accreditation Body & ACA/AUSTEL (Australia), VCCI (Japan)
- Accredited by Industry Canada (Canada) under ACC-LAB (Europe/Canada MRA and APEC/Canada MRA)
- Recognized/Listed by FCC (USA)
- All test results contained in this engineering test report are traceable to National Institute of Standards and Technology (NIST)

EXHIBIT 4. EUT OPERATING CONDITIONS AND CONFIGURATIONS DURING TESTS

4.1. CLIMATE TEST CONDITIONS

The climate conditions of the test environment are as follows:

Temperature:	21°C
Humidity:	51%
Pressure:	102 kPa
Power input source:	7.2 Vdc (Icom Ni-Cd battery pack)

4.2. OPERATIONAL TEST CONDITIONS & ARRANGEMENT FOR TEST SIGNALS

Operating Modes:	The transmitter was operated in a continuous transmission mode with the carrier modulated as specified in the Test Data.
Special Test Software:	None
Special Hardware Used:	None
Transmitter Test Antenna:	The EUT is tested with the transmitter antenna port terminated to a 50 Ohms RF Load.

Transmitter Test Signals	
Frequency Band(s):	Near lowest, near middle & near highest frequencies of each frequency band(s) that the transmitter covers:
<ul style="list-style-type: none"> ▪ 146 - 174 MHz 	<ul style="list-style-type: none"> ▪ 146.05, 160.05 and 173.95 MHz
Transmitter Wanted Output Test Signals:	
<ul style="list-style-type: none"> ▪ RF Power Output (measured maximum output power): ▪ Normal Test Modulation: ▪ Modulating Signal Source: 	5 Watts FM modulation wit 2.5 kHz sine wave signal. External

ULTRATECH GROUP OF LABS

3000 Bristol Circle, Oakville, Ontario, Canada L6H 6G4
 Tel. #: 905-829-1570, Fax. #: 905-829-8050, Email: vhk.ultratech@sympatico.ca, Website: <http://www.ultratech-labs.com>

File #: ICOM27-FTX
 June 25, 2001

- Assessed by ITI (UK) Competent Body, NVLAP (USA) Accreditation Body & ACA/AUSTEL (Australia), VCCI (Japan)
- Accredited by Industry Canada (Canada) under ACC-LAB (Europe/Canada MRA and APEC/Canada MRA)
- Recognized/Listed by FCC (USA)
- All test results contained in this engineering test report are traceable to National Institute of Standards and Technology (NIST)

EXHIBIT 5. SUMMARY OF TEST RESULTS

5.1. LOCATION OF TESTS

All of the measurements described in this report were performed at Ultratech Group of Labs located in the city of Oakville, Province of Ontario, Canada.

Radiated Emissions were performed at the Ultratech's 3 Meter Open Field Test Site (OFTS) situated in the Town of Oakville, province of Ontario.

The above site have been calibrated in accordance with ANSI C63.4, and found to be in compliance with the requirements of Sec. 2.948 of the FCC Rules. The descriptions and site measurement data of the Oakville Open Field Test Site has been filed with FCC office (FCC File No.: 31040/SIT 1300B3) and Industry Canada office (Industry Canada File No.: IC2049). Last Date of Site Calibration: Sep. 20, 1999.

5.2. APPLICABILITY & SUMMARY OF EMC EMISSION TEST RESULTS

FCC PARAGRAPH.	TEST REQUIREMENTS	APPLICABILITY (YES/NO)
90.205 & 2.1046	RF Power Output	Yes
1.1307, 1.1310, 2.1091 & 2.1093	RF Exposure Limit	Yes
90.213 & 2.1055	Frequency Stability	Note 1
90.242(b)(8) & 2.1047(a)	Audio Frequency Response	Note 1
90.210 & 2.1047(b)	Modulation Limiting	Note 1
90.209 90.210 & 2.1049	Emission Limitation & Emission Mask	Yes
90.210, 2.1057 & 2.1051	Emission Limits - Spurious Emissions at Antenna Terminal	Yes
90.210, 2.1057 & 2.1053	Emission Limits - Field Strength of Spurious Emissions	Yes
90.214	Transient Frequency Behavior	Yes

Note 1: Not applicable for Class II Permissive Changes.

5.3. MODIFICATIONS INCORPORATED IN THE EUT FOR COMPLIANCE PURPOSES

None

ULTRATECH GROUP OF LABS

3000 Bristol Circle, Oakville, Ontario, Canada L6H 6G4
Tel. #: 905-829-1570, Fax. #: 905-829-8050, Email: yhk.ultratech@sympatico.ca, Website: <http://www.ultratech-labs.com>

File #: ICOM27-FTX
June 25, 2001

- Assessed by ITI (UK) Competent Body, NVLAP (USA) Accreditation Body & ACA/AUSTEL (Australia), VCCI (Japan)
- Accredited by Industry Canada (Canada) under ACC-LAB (Europe/Canada MRA and APEC/Canada MRA)
- Recognized/Listed by FCC (USA)
- All test results contained in this engineering test report are traceable to National Institute of Standards and Technology (NIST)

EXHIBIT 6. MEASUREMENTS, EXAMINATIONS & TEST DATA FOR EMC EMISSIONS

6.1. TEST PROCEDURES

This section contains test results only. Details of test methods and procedures can be found in Exhibit 8 of this report

6.2. MEASUREMENT UNCERTAINTIES

The measurement uncertainties stated were calculated in accordance with requirements of UKAS Document NIS 81 with a confidence level of 95%. Please refer to Exhibit 7 for Measurement Uncertainties.

6.3. MEASUREMENT EQUIPMENT USED

The measurement equipment used complied with the requirements of the Standards referenced in the Methods & Procedures ANSI C63.4:1992 and CISPR 16-1.

6.4. ESSENTIAL/PRIMARY FUNCTIONS AS DECLARED BY THE MANUFACTURER

The essential function of the EUT is to correctly communicate data to and from radios over RF link.

ULTRATECH GROUP OF LABS

3000 Bristol Circle, Oakville, Ontario, Canada L6H 6G4
Tel. #: 905-829-1570, Fax. #: 905-829-8050, Email: yhk.ultratech@sympatico.ca, Website: <http://www.ultratech-labs.com>

File #: ICOM27-FTX
June 25, 2001

- Assessed by ITI (UK) Competent Body, NVLAP (USA) Accreditation Body & ACA/AUSTEL (Australia), VCCI (Japan)
- Accredited by Industry Canada (Canada) under ACC-LAB (Europe/Canada MRA and APEC/Canada MRA)
- Recognized/Listed by FCC (USA)
- *All test results contained in this engineering test report are traceable to National Institute of Standards and Technology (NIST)*

6.5. RF POWER OUTPUT @ FCC 2.1046 & 90.205

6.5.1. Limits @ FCC 90.205

Please refer to FCC CFR 47, Part 90, Subpart I, Para. 90.205 for specification details.

6.5.2. Method of Measurements

- The transmitter terminal was coupled to the Spectrum Analyzer through a 20 dB attenuator
- Power of the transmitter channel near the lowest, middle and highest of each frequency block/band were measured using the power meter, and the reading was corrected by added the calibrated attenuator's attenuation value and cable loss.
- The RF Output was turned on with standard modulation applied.

6.5.3. Test Equipment List

Test Instruments	Manufacturer	Model No.	Serial No.	Frequency Range
Power Meter	Hewlett Packard	436A	1725A02249	10 kHz – 50 GHz, sensor dependent
Power Sensor	Hewlett Packard	8481A	2702A68983	10 MHz – 18 GHz
Attenuator(s)	Weinschel Corp	24-20-34	BJ2357	DC – 8.5 GHz
Synthesized Function Generator	Stanford Research Systems	DS345	34591	1µHz – 30.2 MHz

6.5.4. Test Arrangement

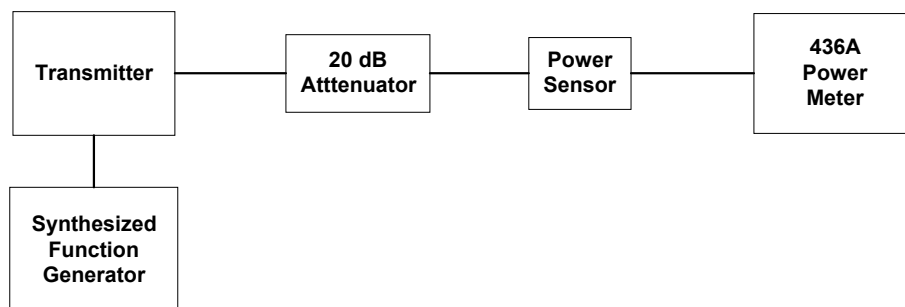

ULTRATECH GROUP OF LABS

3000 Bristol Circle, Oakville, Ontario, Canada L6H 6G4
 Tel. #: 905-829-1570, Fax. #: 905-829-8050, Email: yhk.ultratech@sympatico.ca, Website: <http://www.ultratech-labs.com>

File #: ICOM27-FTX
 June 25, 2001

- Assessed by ITI (UK) Competent Body, NVLAP (USA) Accreditation Body & ACA/AUSTEL (Australia), VCCI (Japan)
- Accredited by Industry Canada (Canada) under ACC-LAB (Europe/Canada MRA and APEC/Canada MRA)
- Recognized/Listed by FCC (USA)
- All test results contained in this engineering test report are traceable to National Institute of Standards and Technology (NIST)

6.5.5. Test Data

Transmitter Channel Output	Fundamental Frequency (MHz)	Measured Power (dBm)	Power Rating (dBm)
Low Power, Wide Band (25kHz channel spacing)			
Lowest	146.05	29.90	30
Middle	160.05	29.91	30
Highest	173.95	30.03	30
High Power, Wide Band (25kHz channel spacing)			
Lowest	146.05	36.90	37
Middle	160.05	37.00	37
Highest	173.95	37.15	37

ULTRATECH GROUP OF LABS

3000 Bristol Circle, Oakville, Ontario, Canada L6H 6G4
Tel. #: 905-829-1570, Fax. #: 905-829-8050, Email: yhk.ultratech@sympatico.ca, Website: <http://www.ultratech-labs.com>

File #: ICOM27-FTX
June 25, 2001

- Assessed by ITI (UK) Competent Body, NVLAP (USA) Accreditation Body & ACA/AUSTEL (Australia), VCCI (Japan)
- Accredited by Industry Canada (Canada) under ACC-LAB (Europe/Canada MRA and APEC/Canada MRA)
- Recognized/Listed by FCC (USA)
- All test results contained in this engineering test report are traceable to National Institute of Standards and Technology (NIST)

6.6. RF EXPOSURE REQUIREMENTS @ 2.1093

Evaluation of RF Exposure Compliance Requirements	
RF Exposure Requirements	Compliance with FCC Rules
SAR Tests for Portable Transmitters <ul style="list-style-type: none">Body/Brain Tissue	<ul style="list-style-type: none">Complies with Limits for Occupational/Controlled exposure: the worst peak spatial – average SAR measured at 7.851 W/kg (EUT at waist position). Please refer to SAR test report for details.

ULTRATECH GROUP OF LABS

3000 Bristol Circle, Oakville, Ontario, Canada L6H 6G4
Tel. #: 905-829-1570, Fax. #: 905-829-8050, Email: yhk.ultratech@sympatico.ca, Website: <http://www.ultratech-labs.com>

File #: ICOM27-FTX
June 25, 2001

- Assessed by ITI (UK) Competent Body, NVLAP (USA) Accreditation Body & ACA/AUSTEL (Australia), VCCI (Japan)
- Accredited by Industry Canada (Canada) under ACC-LAB (Europe/Canada MRA and APEC/Canada MRA)
- Recognized/Listed by FCC (USA)
- All test results contained in this engineering test report are traceable to National Institute of Standards and Technology (NIST)

6.7. EMISSION MASK @ FCC 2.1049, 90.209 & 90.210

6.7.1. Limits @ FCC 90.209 & 90.210

Emissions shall be attenuated below the mean output power of the transmitter as follows:

Frequency Range (MHz)	Maximum Authorized BW (KHz)	Channel Spacing (KHz)	Recommended Frequency Deviation (KHz)	FCC Applicable Mask
150-174	20.0	25.0	5.0	<ul style="list-style-type: none"> 90.210(b): Mask B – Voice 90.210(c): Mask C – Data
150-174	11.25	12.5	2.5	<ul style="list-style-type: none"> 90.210(d): Mask D – Voice & Data

6.7.2. Method of Measurements

Refer to Exhibit 8, § 8.1 of this report for measurement details

6.7.3. Test Equipment List

Test Instruments	Manufacturer	Model No.	Serial No.	Frequency Range
Spectrum Analyzer/ EMI Receiver	Hewlett Packard	HP 8593EM	3412A00103	9 kHz – 26.5 GHz
Attenuator(s)	Bird	DC – 22 GHz
Synthesized Function Generator	Stanford Research Systems	DS345	34591	1µHz – 30.2 MHz

6.7.4. Test Arrangement

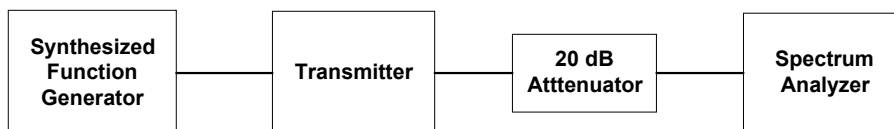

6.7.5. Test Data

Conform. Please refer to Annex 1, test data plots # 1 to 6 for details of measurements

ULTRATECH GROUP OF LABS

3000 Bristol Circle, Oakville, Ontario, Canada L6H 6G4
 Tel. #: 905-829-1570, Fax. #: 905-829-8050, Email: yhk.ultratech@sympatico.ca, Website: <http://www.ultratech-labs.com>

File #: ICOM27-FTX
 June 25, 2001

- Assessed by ITI (UK) Competent Body, NVLAP (USA) Accreditation Body & ACA/AUSTEL (Australia), VCCI (Japan)
- Accredited by Industry Canada (Canada) under ACC-LAB (Europe/Canada MRA and APEC/Canada MRA)
- Recognized/Listed by FCC (USA)
- All test results contained in this engineering test report are traceable to National Institute of Standards and Technology (NIST)

6.8. TRANSMITTER ANTENNA POWER SPURIOUS/HARMONIC CONDUCTED EMISSIONS @ FCC 90.210

6.8.1. Limits @ 90.210

Emissions shall be attenuated below the mean output power of the transmitter as follows:

FCC Rules	Frequency Range	Attenuation Limit (dBc)
90.210(b)&(c) – Voice & data	10 MHz to Lowest frequency of the radio to 10 th harmonic of the highest frequency of the radio	43+10*log(P) or -13 dBm
90.210(d) – Voice & data	10 MHz to Lowest frequency of the radio to 10 th harmonic of the highest frequency of the radio	50+10*log(P) or -20 dBm or 70 dBc whichever is less

6.8.2. Method of Measurements

Refer to Exhibit 8 § 8.2 of this report for measurement details

6.8.3. Test Equipment List

Test Instruments	Manufacturer	Model No.	Serial No.	Frequency Range
Spectrum Analyzer/ EMI Receiver	Hewlett Packard	HP 8593EM	3412A00103	9 kHz – 26.5 GHz
Attenuator(s)	Bird	DC – 22 GHz
Synthesized Function Generator	Stanford Research Systems	DS345	34591	1μHz – 30.2 MHz
High Pass Filter	Mini-Circuits	SHP-250	--	Cut-off Frequency at 225 MHz

6.8.4. Test Arrangement

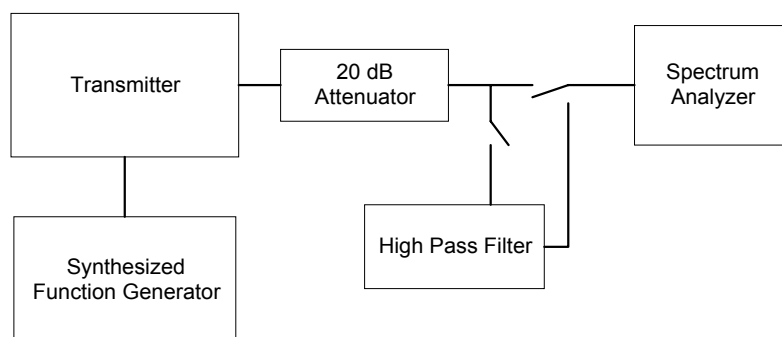

ULTRATECH GROUP OF LABS

3000 Bristol Circle, Oakville, Ontario, Canada L6H 6G4
 Tel. #: 905-829-1570, Fax. #: 905-829-8050, Email: vhk.ultratech@sympatico.ca, Website: <http://www.ultratech-labs.com>

File #: ICOM27-FTX
 June 25, 2001

- Assessed by ITI (UK) Competent Body, NVLAP (USA) Accreditation Body & ACA/AUSTEL (Australia), VCCI (Japan)
- Accredited by Industry Canada (Canada) under ACC-LAB (Europe/Canada MRA and APEC/Canada MRA)
- Recognized/Listed by FCC (USA)
- All test results contained in this engineering test report are traceable to National Institute of Standards and Technology (NIST)

6.8.5. Test Data

Remark:

Test data plots for the following results can be found in Annex 1, test data plots # 7 to 18.

▪ **Near Lowest Frequency (146.05 MHz)**

Fundamental Frequency:	146.05 MHz, Wide Band (25kHz channel spacing)
RF Output Power:	1 W
Modulation:	FM modulation with 2.5 kHz sine wave signal
The emissions were scanned from 10 MHz to 2 GHz and no significant signals were found within 20 dB of the permissible limits.	

Fundamental Frequency:	146.05 MHz, Wide Band (25kHz channel spacing)
RF Output Power:	5 W
Modulation:	FM modulation with 2.5 kHz sine wave signal
The emissions were scanned from 10 MHz to 2 GHz and no significant signals were found within 20 dB of the permissible limits.	

▪ **Near Middle Frequency (160.05 MHz)**

Fundamental Frequency:	160.05 MHz, Wide Band (25kHz channel spacing)
RF Output Power:	1 W
Modulation:	FM modulation with 2.5 kHz sine wave signal
The emissions were scanned from 10 MHz to 2 GHz and no significant signals were found within 20 dB of the permissible limits.	

Fundamental Frequency:	160.05 MHz, Wide Band (25kHz channel spacing)
RF Output Power:	5 W
Modulation:	FM modulation with 2.5 kHz sine wave signal
The emissions were scanned from 10 MHz to 2 GHz and no significant signals were found within 20 dB of the permissible limits.	

ULTRATECH GROUP OF LABS

3000 Bristol Circle, Oakville, Ontario, Canada L6H 6G4
Tel. #: 905-829-1570, Fax. #: 905-829-8050, Email: yhk.ultratech@sympatico.ca, Website: <http://www.ultratech-labs.com>

File #: ICOM27-FTX
June 25, 2001

- Assessed by ITI (UK) Competent Body, NVLAP (USA) Accreditation Body & ACA/AUSTEL (Australia), VCCI (Japan)
- Accredited by Industry Canada (Canada) under ACC-LAB (Europe/Canada MRA and APEC/Canada MRA)
- Recognized/Listed by FCC (USA)
- All test results contained in this engineering test report are traceable to National Institute of Standards and Technology (NIST)

▪ **Near Highest Frequency (173.95 MHz)**

Fundamental Frequency:	173.95 MHz, Wide Band (25kHz channel spacing)
RF Output Power:	1 W
Modulation:	FM modulation with 2.5 kHz sine wave signal
The emissions were scanned from 10 MHz to 2 GHz and no significant signals were found within 20 dB of the permissible limits.	

Fundamental Frequency:	173.95 MHz, Wide Band (25kHz channel spacing)
RF Output Power:	5 W
Modulation:	FM modulation with 2.5 kHz sine wave signal
The emissions were scanned from 10 MHz to 2 GHz and no significant signals were found within 20 dB of the permissible limits.	

ULTRATECH GROUP OF LABS

3000 Bristol Circle, Oakville, Ontario, Canada L6H 6G4
Tel. #: 905-829-1570, Fax. #: 905-829-8050, Email: yhk.ultratech@sympatico.ca, Website: <http://www.ultratech-labs.com>

File #: ICOM27-FTX
June 25, 2001

- Assessed by ITI (UK) Competent Body, NVLAP (USA) Accreditation Body & ACA/AUSTEL (Australia), VCCI (Japan)
- Accredited by Industry Canada (Canada) under ACC-LAB (Europe/Canada MRA and APEC/Canada MRA)
- Recognized/Listed by FCC (USA)
- *All test results contained in this engineering test report are traceable to National Institute of Standards and Technology (NIST)*

6.9. TRANSMITTER SPURIOUS/HARMONIC RADIATED EMISSIONS @ FCC 90.210

6.9.1. Limits @ FCC 90.210

Emissions shall be attenuated below the mean output power of the transmitter as follows:

Frequency Range (MHz)	Maximum Authorized BW (KHz)	Channel Spacing (KHz)	Recommended Frequency Deviation (KHz)	FCC Applicable Mask
150-174	20.0	25.0	5.0	<ul style="list-style-type: none"> 90.210(b): Mask B – Voice 90.210(c): Mask C – Data
150-174	11.25	12.5	2.5	<ul style="list-style-type: none"> 90.210(d): Mask D – Voice & Data

6.9.2. Method of Measurements

Refer to Exhibit 8, § 8.3 of this report for measurement details

6.9.3. Test Equipment List

Test Instruments	Manufacturer	Model No.	Serial No.	Frequency Range
Spectrum Analyzer/EMI Receiver	Advantest	R3271	15050203	100 Hz to 32 GHz with external mixer for frequency above 32 GHz
Microwave Amplifier	Hewlett Packard	HP 83017A	3116A00661	1 GHz to 26.5 GHz
Active Loop Antenna	EMCO	6507	8906-1167	1 kHz – 30 MHz
Biconilog Antenna	EMCO	3143	1029	20 MHz to 2 GHz
Horn Antenna	EMCO	3155	9701-5061	1 GHz – 18 GHz
Horn Antenna with Mixer	EMCO	3160-09	1007	18 GHz – 26.5 GHz
Horn Antenna with Mixer	EMCO	3160-10	1001	26.5 GHz – 40 GHz
Synthesized Function Generator	Stanford Research Systems	DS345	34591	1µHz – 30.2 MHz

ULTRATECH GROUP OF LABS

3000 Bristol Circle, Oakville, Ontario, Canada L6H 6G4
Tel. #: 905-829-1570, Fax. #: 905-829-8050, Email: yhk.ultratech@sympatico.ca, Website: <http://www.ultratech-labs.com>

File #: ICOM27-FTX
June 25, 2001

- Assessed by ITI (UK) Competent Body, NVLAP (USA) Accreditation Body & ACA/AUSTEL (Australia), VCCI (Japan)
- Accredited by Industry Canada (Canada) under ACC-LAB (Europe/Canada MRA and APEC/Canada MRA)
- Recognized/Listed by FCC (USA)
- All test results contained in this engineering test report are traceable to National Institute of Standards and Technology (NIST)

6.9.4. Test Arrangement

The following drawing shows details of the test setup for radiated emissions measurements

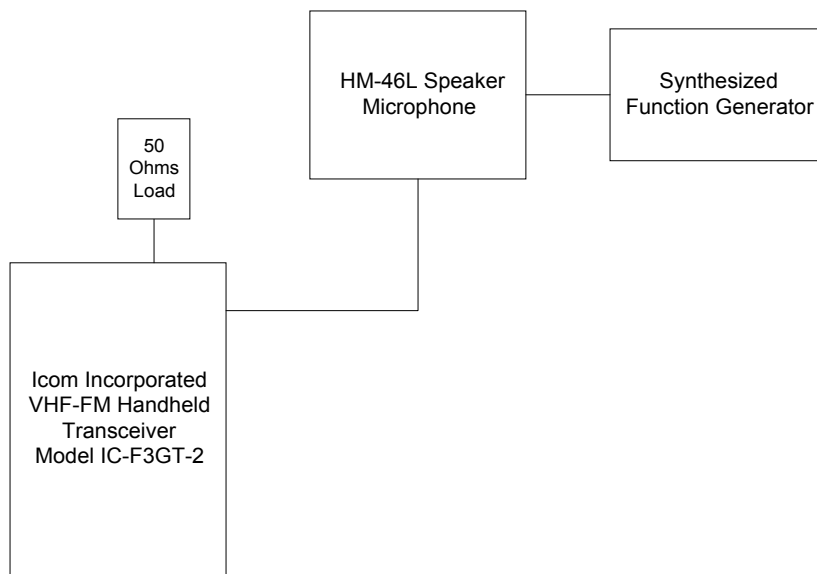

ULTRATECH GROUP OF LABS

3000 Bristol Circle, Oakville, Ontario, Canada L6H 6G4
Tel. #: 905-829-1570, Fax. #: 905-829-8050, Email: yhk.ultratech@sympatico.ca, Website: <http://www.ultratech-labs.com>

File #: ICOM27-FTX
June 25, 2001

- Assessed by ITI (UK) Competent Body, NVLAP (USA) Accreditation Body & ACA/AUSTEL (Australia), VCCI (Japan)
- Accredited by Industry Canada (Canada) under ACC-LAB (Europe/Canada MRA and APEC/Canada MRA)
- Recognized/Listed by FCC (USA)
- All test results contained in this engineering test report are traceable to National Institute of Standards and Technology (NIST)

6.9.5. Test Data

Remark:

The transmitter spurious/harmonic radiated emissions were performed at 3 meters distance with RF output power level of Equipment Under Test set at high power (5 Watts) and operating at wide band (25 kHz channel spacing).

▪ **Near Lowest Frequency (146.05 MHz)**

Fundamental Frequency:		146.05 MHz					
RF Output Power:		5 W					
Modulation:		FM modulation with 2.5 kHz sine wave signal					
Frequency (MHz)	RF Field Level @ 3 m (dBμV/m)	RF Power Level (dBm)	Detector Used (Peak/QP)	Antenna Plane (H/V)	Limit @ 3 m (dBm)	Margin (dB)	Pass/Fail
292.10	51.79	-45.7	Peak	V	-13.0	-32.7	Pass
292.10	59.84	-37.7	Peak	H	-13.0	-24.7	Pass
438.15	53.53	-44.0	Peak	V	-13.0	-31.0	Pass
438.15	55.13	-42.4	Peak	H	-13.0	-29.4	Pass
584.20	50.40	-47.1	Peak	V	-13.0	-34.1	Pass
584.20	52.10	-45.4	Peak	H	-13.0	-32.4	Pass
730.25	47.43	-50.1	Peak	V	-13.0	-37.1	Pass
730.25	46.77	-50.7	Peak	H	-13.0	-37.7	Pass
876.30	45.02	-52.5	Peak	V	-13.0	-39.5	Pass
876.30	48.97	-48.5	Peak	H	-13.0	-35.5	Pass
1022.35	47.06	-50.4	Peak	V	-13.0	-37.4	Pass
1022.35	40.56	-56.9	Peak	H	-13.0	-43.9	Pass
1168.40	41.41	-56.1	Peak	V	-13.0	-43.1	Pass
1168.40	38.38	-59.1	Peak	H	-13.0	-46.1	Pass
1314.45	42.97	-54.5	Peak	V	-13.0	-41.5	Pass
1314.45	42.16	-55.3	Peak	H	-13.0	-42.3	Pass
1460.50	43.78	-53.7	Peak	V	-13.0	-40.7	Pass
1460.50	45.94	-51.6	Peak	H	-13.0	-38.6	Pass
The emissions were scanned from 10 MHz to 2 GHz and all emissions within 50 dB below the limits were recorded.							

ULTRATECH GROUP OF LABS

3000 Bristol Circle, Oakville, Ontario, Canada L6H 6G4
 Tel. #: 905-829-1570, Fax. #: 905-829-8050, Email: vhk.ultratech@sympatico.ca, Website: <http://www.ultratech-labs.com>

File #: ICOM27-FTX
 June 25, 2001

- Assessed by ITI (UK) Competent Body, NVLAP (USA) Accreditation Body & ACA/AUSTEL (Australia), VCCI (Japan)
- Accredited by Industry Canada (Canada) under ACC-LAB (Europe/Canada MRA and APEC/Canada MRA)
- Recognized/Listed by FCC (USA)
- All test results contained in this engineering test report are traceable to National Institute of Standards and Technology (NIST)

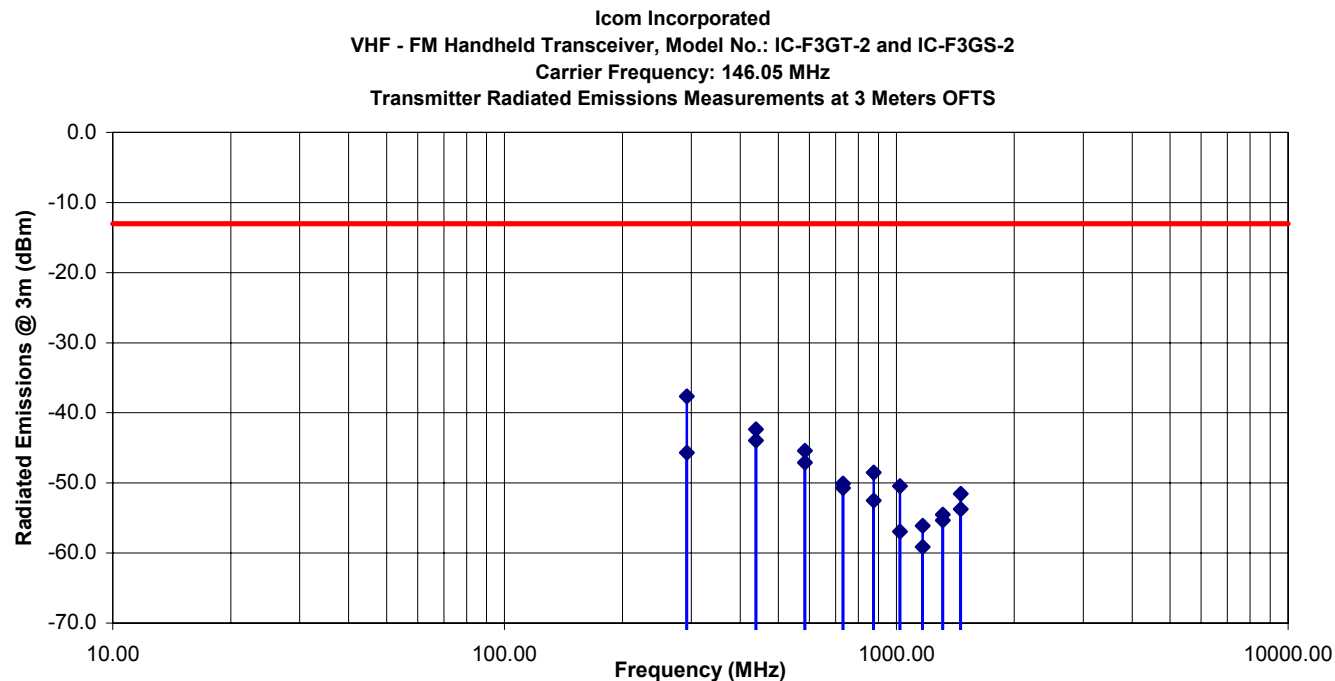

ULTRATECH GROUP OF LABS

3000 Bristol Circle, Oakville, Ontario, Canada L6H 6G4
Tel. #: 905-829-1570, Fax. #: 905-829-8050, Email: yhk.ultratech@sympatico.ca, Website: <http://www.ultratech-labs.com>

File #: ICOM27-FTX
June 25, 2001

- Assessed by ITI (UK) Competent Body, NVLAP (USA) Accreditation Body & ACA/AUSTEL (Australia), VCCI (Japan)
- Accredited by Industry Canada (Canada) under ACC-LAB (Europe/Canada MRA and APEC/Canada MRA)
- Recognized/Listed by FCC (USA)
- All test results contained in this engineering test report are traceable to National Institute of Standards and Technology (NIST)

▪ **Near Middle Frequency (160.05 MHz)**

Fundamental Frequency: 160.05 MHz							
RF Output Power: 5 W							
Modulation: FM modulation with 2.5 kHz sine wave signal							
Frequency (MHz)	RF Field Level @ 3 m (dBμV/m)	RF Power Level (dBm)	Detector Used (Peak/QP)	Antenna Plane (H/V)	Limit @ 3 m (dBm)	Margin (dB)	Pass/Fail
320.10	58.34	-39.2	Peak	V	-13.0	-26.2	Pass
320.10	63.59	-33.9	Peak	H	-13.0	-20.9	Pass
480.15	56.52	-41.0	Peak	V	-13.0	-28.0	Pass
480.15	52.33	-45.2	Peak	H	-13.0	-32.2	Pass
640.20	49.56	-47.9	Peak	V	-13.0	-34.9	Pass
640.20	47.85	-49.7	Peak	H	-13.0	-36.7	Pass
800.25	40.06	-57.4	Peak	V	-13.0	-44.4	Pass
800.25	35.07	-62.4	Peak	H	-13.0	-49.4	Pass
960.30	34.46	-63.0	Peak	V	-13.0	-50.0	Pass
960.30	35.17	-62.3	Peak	H	-13.0	-49.3	Pass
1120.35	36.56	-60.9	Peak	H	-13.0	-47.9	Pass
1280.40	36.81	-60.7	Peak	V	-13.0	-47.7	Pass
1280.40	39.34	-58.2	Peak	H	-13.0	-45.2	Pass
1440.45	36.50	-61.0	Peak	V	-13.0	-48.0	Pass
1440.45	37.63	-59.9	Peak	H	-13.0	-46.9	Pass
1600.50	38.47	-59.0	Peak	V	-13.0	-46.0	Pass
1600.50	39.34	-58.2	Peak	H	-13.0	-45.2	Pass
The emissions were scanned from 10 MHz to 2 GHz and all emissions within 50 dB below the limits were recorded.							

ULTRATECH GROUP OF LABS

3000 Bristol Circle, Oakville, Ontario, Canada L6H 6G4
Tel. #: 905-829-1570, Fax. #: 905-829-8050, Email: yhk.ultratech@sympatico.ca, Website: <http://www.ultratech-labs.com>

File #: ICOM27-FTX
June 25, 2001

- Assessed by ITI (UK) Competent Body, NVLAP (USA) Accreditation Body & ACA/AUSTEL (Australia), VCCI (Japan)
- Accredited by Industry Canada (Canada) under ACC-LAB (Europe/Canada MRA and APEC/Canada MRA)
- Recognized/Listed by FCC (USA)
- All test results contained in this engineering test report are traceable to National Institute of Standards and Technology (NIST)

Icom Incorporated
VHF - FM Handheld Transceiver, Model No.: IC-F3GT-2 and IC-F3GS-2
Carrier Frequency: 160.05 MHz
Transmitter Radiated Emissions Measurements at 3 Meters OFTS

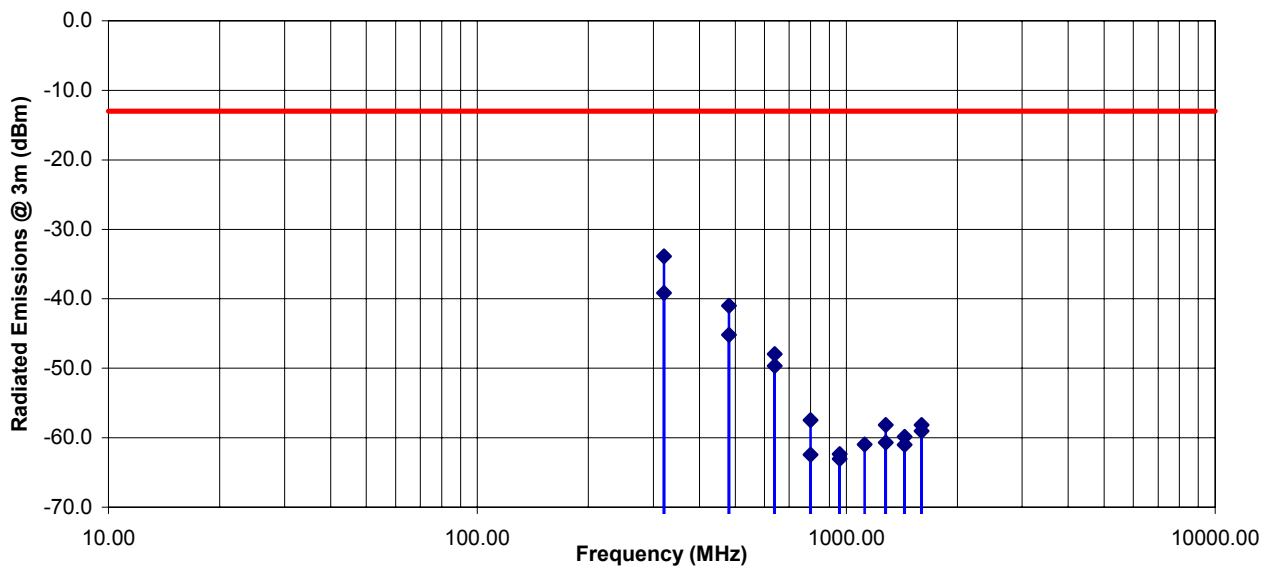

ULTRATECH GROUP OF LABS

3000 Bristol Circle, Oakville, Ontario, Canada L6H 6G4
Tel. #: 905-829-1570, Fax. #: 905-829-8050, Email: yhk.ultratech@sympatico.ca, Website: <http://www.ultratech-labs.com>

File #: ICOM27-FTX
June 25, 2001

- Assessed by ITI (UK) Competent Body, NVLAP (USA) Accreditation Body & ACA/AUSTEL (Australia), VCCI (Japan)
- Accredited by Industry Canada (Canada) under ACC-LAB (Europe/Canada MRA and APEC/Canada MRA)
- Recognized/Listed by FCC (USA)
- All test results contained in this engineering test report are traceable to National Institute of Standards and Technology (NIST)

▪ **Near Highest Frequency (173.95 MHz)**

Fundamental Frequency: 173.95 MHz							
RF Output Power: 5 W							
Modulation: FM modulation with 2.5 kHz sine wave signal							
Frequency (MHz)	RF Field Level @ 3 m (dBμV/m)	RF Power Level (dBm)	Detector Used (Peak/QP)	Antenna Plane (H/V)	Limit @ 3 m (dBm)	Margin (dB)	Pass/Fail
347.90	57.89	-39.6	Peak	V	-13.0	-26.6	Pass
347.90	60.64	-36.9	Peak	H	-13.0	-23.9	Pass
521.85	57.33	-40.2	Peak	V	-13.0	-27.2	Pass
521.85	54.43	-43.1	Peak	H	-13.0	-30.1	Pass
695.80	42.31	-55.2	Peak	V	-13.0	-42.2	Pass
695.80	50.14	-47.4	Peak	H	-13.0	-34.4	Pass
869.75	34.99	-62.5	Peak	V	-13.0	-49.5	Pass
1043.70	35.44	-62.1	Peak	V	-13.0	-49.1	Pass
1043.70	35.53	-62.0	Peak	H	-13.0	-49.0	Pass
1217.65	34.84	-62.7	Peak	V	-13.0	-49.7	Pass
1391.60	35.97	-61.5	Peak	V	-13.0	-48.5	Pass
1565.55	38.09	-59.4	Peak	V	-13.0	-46.4	Pass
1565.55	39.50	-58.0	Peak	H	-13.0	-45.0	Pass
1739.50	34.53	-63.0	Peak	V	-13.0	-50.0	Pass
The emissions were scanned from 10 MHz to 2 GHz and all emissions within 50 dB below the limits were recorded.							

ULTRATECH GROUP OF LABS

3000 Bristol Circle, Oakville, Ontario, Canada L6H 6G4
Tel. #: 905-829-1570, Fax. #: 905-829-8050, Email: yhk.ultratech@sympatico.ca, Website: <http://www.ultratech-labs.com>

File #: ICOM27-FTX
June 25, 2001

- Assessed by ITI (UK) Competent Body, NVLAP (USA) Accreditation Body & ACA/AUSTEL (Australia), VCCI (Japan)
- Accredited by Industry Canada (Canada) under ACC-LAB (Europe/Canada MRA and APEC/Canada MRA)
- Recognized/Listed by FCC (USA)
- All test results contained in this engineering test report are traceable to National Institute of Standards and Technology (NIST)

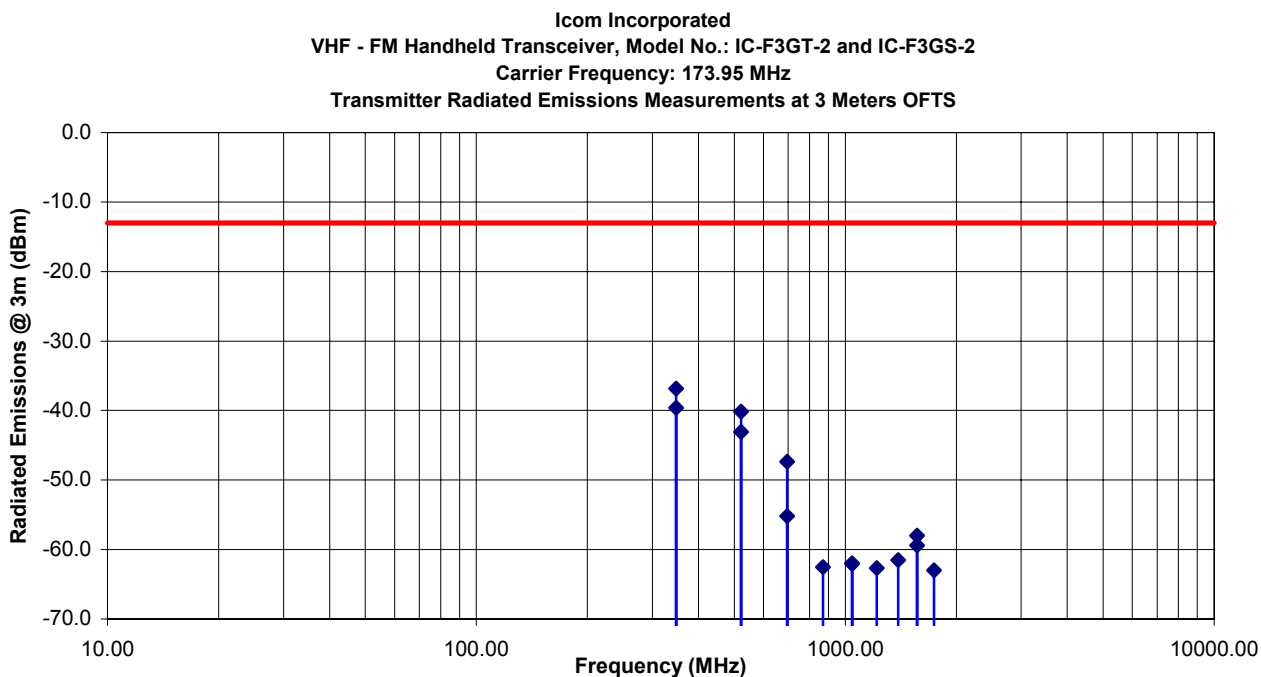

ULTRATECH GROUP OF LABS

3000 Bristol Circle, Oakville, Ontario, Canada L6H 6G4
Tel. #: 905-829-1570, Fax. #: 905-829-8050, Email: yhk.ultratech@sympatico.ca, Website: <http://www.ultratech-labs.com>

File #: ICOM27-FTX
June 25, 2001

- Assessed by ITI (UK) Competent Body, NVLAP (USA) Accreditation Body & ACA/AUSTEL (Australia), VCCI (Japan)
- Accredited by Industry Canada (Canada) under ACC-LAB (Europe/Canada MRA and APEC/Canada MRA)
- Recognized/Listed by FCC (USA)
- All test results contained in this engineering test report are traceable to National Institute of Standards and Technology (NIST)

6.10. TRANSIENT FREQUENCY BEHAVIOR @ 90.214

6.10.1. Limits

Transient frequencies must be within the maximum frequency difference limits during the time intervals indicated:

Time intervals ^{1, 2}	Maximum frequency difference ³	All equipment	
		150 to 174 MHz	421 to 512 MHz
Transient Frequency Behavior for Equipment Designed to Operate on 25 kHz Channels			
t_1 ⁴	± 25.0 kHz	5.0 ms	10.0 ms
t_2	± 12.5 kHz	20.0 ms	25.0 ms
t_3 ⁴	± 25.0 kHz	5.0 ms	10.0 ms
Transient Frequency Behavior for Equipment Designed to Operate on 12.5 kHz Channels			
t_1 ⁴	± 12.5 kHz	5.0 ms	10.0 ms
t_2	± 6.25 kHz	20.0 ms	25.0 ms
t_3 ⁴	± 12.5 kHz	5.0 ms	10.0 ms
Transient Frequency Behavior for Equipment Designed to Operate on 6.25 kHz Channels			
t_1 ⁴	± 6.25 kHz	5.0 ms	10.0 ms
t_2	± 3.125 kHz	20.0 ms	25.0 ms
t_3 ⁴	± 6.25 kHz	5.0 ms	10.0 ms

- 1 t_{on} is the instant when a 1 kHz test signal is completely suppressed, including any capture time due to phasing.
 t_1 is the time period immediately following t_{on} .
 t_2 is the time period immediately following t_1 .
 t_3 is the time period from the instant when the transmitter is turned off until t_{off} .
 t_{off} is the instant when the 1 kHz test signal starts to rise.
- 2 During the time from the end of t_2 to the beginning of t_3 , the frequency difference must not exceed the limits specified in § 90.213.
- 3 Difference between the actual transmitter frequency and the assigned transmitter frequency.
- 4 If the transmitter carrier output power rating is 6 watts or less, the frequency difference during this time period may exceed the maximum frequency difference for this time period.

6.10.2. Method of Measurements

Refer to Exhibit 8, § 8.4 of this test report and ANSI/TIA/EIA - 603 - 1992, Sec. 2.2.19, Page 83

ULTRATECH GROUP OF LABS

3000 Bristol Circle, Oakville, Ontario, Canada L6H 6G4
Tel. #: 905-829-1570, Fax. #: 905-829-8050, Email: vhk.ultratech@sympatico.ca, Website: <http://www.ultratech-labs.com>

File #: ICOM27-FTX
June 25, 2001

- Assessed by ITI (UK) Competent Body, NVLAP (USA) Accreditation Body & ACA/AUSTEL (Australia), VCCI (Japan)
- Accredited by Industry Canada (Canada) under ACC-LAB (Europe/Canada MRA and APEC/Canada MRA)
- Recognized/Listed by FCC (USA)
- All test results contained in this engineering test report are traceable to National Institute of Standards and Technology (NIST)

6.10.3. Test Equipment List

Test Instruments	Manufacturer	Model No.	Serial No.	Frequency Range
Audio Signal Generator	Krohn-Hite	2000	462	0.03 Hz ~ 30 MHz
RF Synthesized Signal Generator	Fluke	6061A	4770301	10 kHz – 1050 MHz
Radio Communication Test Set	Marconi Instruments	2955	132037/226	400kHz - 1000 MHz
Network Combiner	Mini-Circuit	15542	--	DC to 32 GHz
Infinium Digitizing Oscilloscope	Hewlett Packard	54810A	US38380192	DC to 500 MHz, 1 Gsa/s
RF Detector	Amphenol	UG-1094/U1050	--	--
Attenuator	Weinschel Corp	2320-34	BH-7876	DC – 18 GHz

6.10.4. Test Arrangement

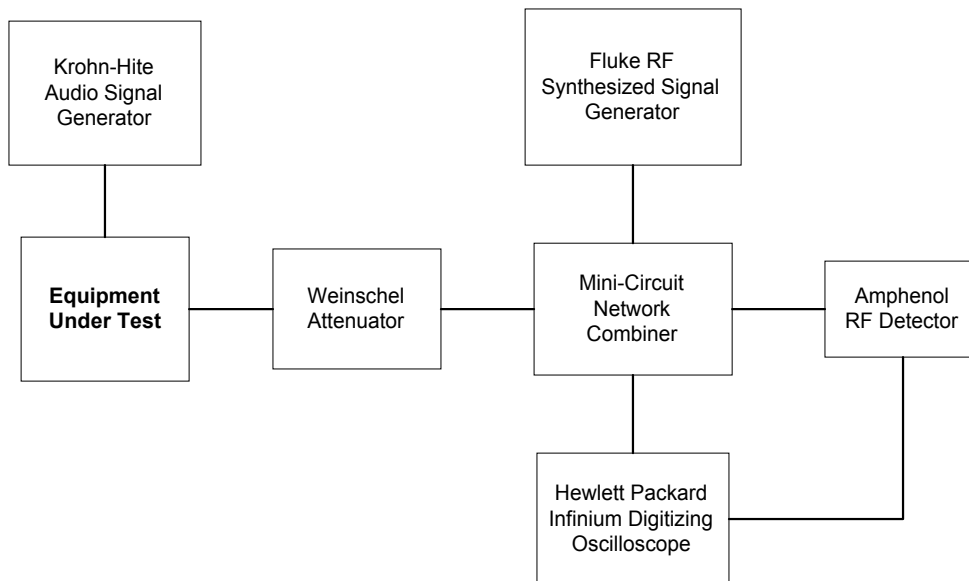

ULTRATECH GROUP OF LABS

3000 Bristol Circle, Oakville, Ontario, Canada L6H 6G4
 Tel. #: 905-829-1570, Fax. #: 905-829-8050, Email: yhk.ultratech@sympatico.ca, Website: <http://www.ultratech-labs.com>

File #: ICOM27-FTX
 June 25, 2001

- Assessed by ITI (UK) Competent Body, NVLAP (USA) Accreditation Body & ACA/AUSTEL (Australia), VCCI (Japan)
- Accredited by Industry Canada (Canada) under ACC-LAB (Europe/Canada MRA and APEC/Canada MRA)
- Recognized/Listed by FCC (USA)
- All test results contained in this engineering test report are traceable to National Institute of Standards and Technology (NIST)

6.10.5. Test Data

Remark:

Test data plots for the following results can be found in Annex 1, test data plots # 19 to 22.

- **25 kHz Channel Spacing Operation**

Time Interval	Transient Frequency	Transient Frequency Limit
Test Configuration #1: Unmodulated		
t ₁ (5 ms) Switch ON Condition	+20.1 kHz	25 kHz or no limit for RF Output Power < 6 Watts
t ₂ (20 ms) Switch On Condition	0	12.5 kHz
After t ₂ (10 ms) Switch On Condition	0	FCC Limit = ± 730 Hz (5 ppm @ 146.05 MHz)
Before t ₃ (10 ms) Switch Off Condition	0	FCC Limit = ± 730 Hz (5 ppm @ 146.05 MHz)
t ₃ (5 ms) Switch Off Condition	+19.3 kHz	25 kHz or no limit for RF Output Power < 6 Watts
Test Configuration #2: FM modulation with 2.5 KHz Sine Wave, Freq. Dev.: ... KHz		
t ₁ (5 ms) Switch ON Condition	+7.6 kHz	25 kHz or no limit for RF Output Power < 6 Watts
t ₂ (20 ms) Switch On Condition	0	12.5 kHz
After t ₂ (10 ms) Switch On Condition	0	FCC Limit = ± 730 Hz (5 ppm @ 146.05 MHz)
Before t ₃ (10 ms) Switch Off Condition	0	FCC Limit = ± 730 Hz (5 ppm @ 146.05 MHz)
t ₃ (5 ms) Switch Off Condition	+8.1 kHz	25 kHz or no limit for RF Output Power < 6 Watts

ULTRATECH GROUP OF LABS

3000 Bristol Circle, Oakville, Ontario, Canada L6H 6G4
Tel. #: 905-829-1570, Fax. #: 905-829-8050, Email: yhk.ultratech@sympatico.ca, Website: <http://www.ultratech-labs.com>

File #: ICOM27-FTX
June 25, 2001

- Assessed by ITI (UK) Competent Body, NVLAP (USA) Accreditation Body & ACA/AUSTEL (Australia), VCCI (Japan)
- Accredited by Industry Canada (Canada) under ACC-LAB (Europe/Canada MRA and APEC/Canada MRA)
- Recognized/Listed by FCC (USA)
- All test results contained in this engineering test report are traceable to National Institute of Standards and Technology (NIST)

EXHIBIT 7. MEASUREMENT UNCERTAINTY

The measurement uncertainties stated were calculated in accordance with the requirements of NIST Technical Note 1297 and NIS 81 (1994)

7.1. RADIATED EMISSION MEASUREMENT UNCERTAINTY

CONTRIBUTION (Radiated Emissions)	PROBABILITY DISTRIBUTION	UNCERTAINTY (+ dB)	
		3 m	10 m
Antenna Factor Calibration	Normal (k=2)	± 1.0	± 1.0
Cable Loss Calibration	Normal (k=2)	± 0.3	± 0.5
EMI Receiver specification	Rectangular	± 1.5	± 1.5
Antenna Directivity	Rectangular	+0.5	+0.5
Antenna factor variation with height	Rectangular	± 2.0	± 0.5
Antenna phase center variation	Rectangular	0.0	± 0.2
Antenna factor frequency interpolation	Rectangular	± 0.25	± 0.25
Measurement distance variation	Rectangular	± 0.6	± 0.4
Site imperfections	Rectangular	± 2.0	± 2.0
Mismatch: Receiver VRC $\Gamma_1 = 0.2$ Antenna VRC $\Gamma_R = 0.67(\text{Bi}) 0.3 (\text{Lp})$ Uncertainty limits $20\text{Log}(1 \pm \Gamma_1 \Gamma_R)$	U-Shaped	+1.1 -1.25	± 0.5
System repeatability	Std. Deviation	± 0.5	± 0.5
Repeatability of EUT		-	-
Combined standard uncertainty	Normal	+2.19 / -2.21	+1.74 / -1.72
Expanded uncertainty U	Normal (k=2)	+4.38 / -4.42	+3.48 / -3.44

Calculation for maximum uncertainty when 3m biconical antenna including a factor of k=2 is used:

$$U = 2u_c(y) = 2x(+2.19) = +4.38 \text{ dB} \quad \text{And} \quad U = 2u_c(y) = 2x(-2.21) = -4.42 \text{ dB}$$

ULTRATECH GROUP OF LABS

3000 Bristol Circle, Oakville, Ontario, Canada L6H 6G4
Tel. #: 905-829-1570, Fax. #: 905-829-8050, Email: vhk.ultratech@sympatico.ca, Website: <http://www.ultratech-labs.com>

File #: ICOM27-FTX
June 25, 2001

- Assessed by ITI (UK) Competent Body, NVLAP (USA) Accreditation Body & ACA/AUSTEL (Australia), VCCI (Japan)
- Accredited by Industry Canada (Canada) under ACC-LAB (Europe/Canada MRA and APEC/Canada MRA)
- Recognized/Listed by FCC (USA)
- All test results contained in this engineering test report are traceable to National Institute of Standards and Technology (NIST)

EXHIBIT 8. MEASUREMENT METHODS

8.1. EMISSION MASK

Voice or Digital Modulation Through a Voice Input Port @ 2.1049(c)(i):- The transmitter was modulated by a 2.5 KHz tone signal at an input level 16 dB greater than that required to produce 50% modulation (e.g.: ± 2.5 KHz peak deviation at 1 KHz modulating frequency). The input level was established at the frequency of maximum response of the audio modulating circuit.

Digital Modulation Through a Data Input Port @ 2.1049(h):- Transmitters employing digital modulation techniques - when modulated by an input signal such that its amplitude and symbol rate represent the maximum rated conditions under which the equipment will be operated. The signal shall be applied through any filter networks, pseudo-random generators or other devices required in normal service. Additionally, the Emission Masks shall be shown for operation with any devices used for modifying the spectrum when such devices are operational at the discretion of the user.

The following spectrum analyzer bandwidth shall be used for measurement of Emission Mask/Out-of-Band Emission Measurements:

- (1) For 25 kHz Channel Spacing: RBW = 300 Hz
- (2) For 12.5 kHz or 6.25 kHz Channel Spacings: RBW = 100 Hz

The all cases the Video Bandwidth shall be equal or greater than the measuring bandwidth.

8.2. SPURIOUS EMISSIONS (CONDUCTED)

With transmitter modulation characteristics described in Out-of-Band Emissions measurements @ 2.1049, the transmitter spurious and harmonic emissions were scanned. The spurious and harmonic emissions were measured with the Spectrum Analyzer controls set as RBW = 30 kHz minimum, VBW \geq RBW and SWEEP TIME = AUTO). The transmitter was operated at a full rated power output, and modulated as follows:

FCC CFR 47, Para. 2.1057 - Frequency spectrum to be investigated:- The spectrum was investigated from the lowest radio generated in the equipment up to at least the 10th harmonic of the carrier frequency or to the highest frequency practicable in the present state of the art of measuring techniques, whichever is lower. Particular attention should be paid to harmonics and subharmonics of the carrier frequency. Radiation at the frequencies of multiplier stages should be checked. The amplitude of spurious emissions which are attenuated more than 20 dB below the permissible value need not be reported.

FCC CFR 47, Para. 2.1051 - Spurious Emissions at Antenna Terminal:- The radio frequency voltage or powers generated within the equipment and appearing on a spurious frequency shall be checked at the equipment output terminals when properly loaded with a suitable artificial antenna. Curves or equivalent data shall show the magnitude of the harmonic and other spurious emission that can be detected when the equipment is operated under the conditions specified in 2.1049 as appropriate. The magnitude of spurious emissions which are attenuated more than 20 dB below the permissible value need not be specified.

ULTRATECH GROUP OF LABS

3000 Bristol Circle, Oakville, Ontario, Canada L6H 6G4
Tel. #: 905-829-1570, Fax. #: 905-829-8050, Email: vhk.ultratech@sympatico.ca, Website: <http://www.ultratech-labs.com>

File #: ICOM27-FTX
June 25, 2001

- Assessed by ITI (UK) Competent Body, NVLAP (USA) Accreditation Body & ACA/AUSTEL (Australia), VCCI (Japan)
- Accredited by Industry Canada (Canada) under ACC-LAB (Europe/Canada MRA and APEC/Canada MRA)
- Recognized/Listed by FCC (USA)
- All test results contained in this engineering test report are traceable to National Institute of Standards and Technology (NIST)

8.3. SPURIOUS EMISSIONS (RADIATED)

With transmitter modulation characteristics described in Out-of-Band Emissions measurements @ 2.1049, the transmitter spurious and harmonic emissions were scanned. The spurious and harmonic emissions were measured with the Spectrum Analyzer controls set as RBW = 100 kHz minimum, VBW \geq RBW and SWEEP TIME = AUTO). The transmitter was operated at a full rated power output, and modulated as follows:

FCC CFR 47, Para. 2.1057 - Frequency spectrum to be investigated:- The spectrum was investigated from the lowest radio generated in the equipment up to at least the 10th harmonic of the carrier frequency or to the highest frequency practicable in the present state of the art of measuring techniques, whichever is lower. Particular attention should be paid to harmonics and subharmonics of the carrier frequency. Radiation at the frequencies of multiplier stages should be checked. The amplitude of spurious emissions which are attenuated more than 20 dB below the permissible value need not be reported.

FCC CFR 47, Para. 2.1053 - Field Strength Spurious Emissions

- (a) Measurements was made to detect spurious emissions radiated directly from the cabinet, control circuits, power leads, or intermediate circuit elements under normal conditions of installation and operation. Curves or equivalent data were supplied showing the magnitude of each harmonic and other spurious emission. For this test, single sideband, independent sideband, and controlled carrier transmitters shall be modulated under the conditions specified in paragraph 2.1049(c) as appropriate. For equipment operating on frequencies below 1 GHz, an Open Field Test is normally required, with the measuring instrument antenna located in the far field at all test frequencies. In event it is either impractical or impossible to make open field measurements (e.g. a broadcast transmitter installed in a building) measurement will be accepted of the equipment as installed. Such measurements must be accompanied by a description of the site where the measurements were made showing the location of any possible source of reflections which might distort the field strength measurements. Information submitted shall include the relative radiated power of each spurious emission with the reference to the rated power output of the transmitter, assuming all emissions are radiated from half-wave dipole antennas.
- (b) Measurements specified in paragraph (a) of this section shall be made for the following equipment:
- (1) Those in which the spurious emission are required to be 60 dB or more below the mean power of the transmitter.
 - (2) All equipment operating on frequencies higher than 25 MHz
 - (3) All equipment where the antenna is an integral part of, and attached directly to the transmitter.
 - (4) Other types of equipment as required, when deemed necessary by the Commission.

Maximizing RF Emission Level:

- (a) The measurements was performed with standard modulation
- (b) Test was performed at listed 3m open area test site (listed with FCC, IC, ITI, NVLAP, ACA & VCCI).
- (c) The transmitter under test was placed at the specified height on a non-conducting turntable (80 cm height)
- (d) The biconilog Antenna (20 MHz to 1 GHz) or Horn Antenna (1 GHz to 18 GHz) was used for measuring.
- (e) The spectrum analyzer was tuned to transmitter carrier frequency. The test antenna was lowered or raised from 1 to 4 meters until the maximum signal level was detected.
- (f) The transmitter was rotated through 360° about a vertical axis until a higher maximum signal was received.
- (g) The test antenna was lowered or raised again from 1 to 4 meters until a maximum was obtained. This level was recorded.

ULTRATECH GROUP OF LABS

3000 Bristol Circle, Oakville, Ontario, Canada L6H 6G4
Tel. #: 905-829-1570, Fax. #: 905-829-8050, Email: yhk.ultratech@sympatico.ca, Website: <http://www.ultratech-labs.com>

File #: ICOM27-FTX
June 25, 2001

- Assessed by ITI (UK) Competent Body, NVLAP (USA) Accreditation Body & ACA/AUSTEL (Australia), VCCI (Japan)
- Accredited by Industry Canada (Canada) under ACC-LAB (Europe/Canada MRA and APEC/Canada MRA)
- Recognized/Listed by FCC (USA)
- All test results contained in this engineering test report are traceable to National Institute of Standards and Technology (NIST)

- (h) The recorded reading was corrected to the true field strength level by adding the antenna factor, cable loss and subtracting the pre-amplifier gain.
- (i) The field strength level measured at 3m is converted to the power in dBm by subtracting a constant factor of 97.5 dB

METHOD OF CALCULATION FOR TRANSMITTED POWER (P) FROM THE MEASURED FIELD STRENGTH LEVEL (E):

According to IEC 801-3, the power density can be calculated as follows:

$$S = P / (4 \times \text{PI} \times D^2) \quad \text{Where: } S: \text{ Power density in watts per square feet}$$

P: Transmitted power in watts
PI: 3.1416
D: Distance in meters

The power density S (W/m²) and electric field E (V/m) is related by:

$$S = E^2 / (120 \times \text{PI})$$

Accordingly, the field intensity of isotropic radiator in free space can be expressed as follows:

$$E = (30 \times P)^{1/2} / D = 5.5 \times (P)^{1/2} / D$$

For Halfwave dipole antenna or other antennas correlated to dipole in direction of maximum radiation:

$$S = (1.64 \times P) / (4 \times \text{PI} \times D^2)$$
$$E = (49.2 \times P)^{1/2} / D = 7.01 \times (P)^{1/2} / D$$

$$P = (E \times D / 7.01)^2$$

Calculation of transmitted power P (dBm) given a measured field intensity E (dBμV/m):

$$\begin{aligned} P(W) &= [E(V/m) \times D / 7.01]^2 \\ P(mW) &= P(W) \times 1000 \\ \Rightarrow P(dBm) &= 10 \log P(mW) \\ &= 20 \log E(V/m) + 20 \log(D) - 20 \log(7.01) + 10 \log 1000 \\ &= E(dBV/m) + 20 \log D + 13 \\ &= E(dB\mu V/m) - 120 + 20 \log(D) + 13 \\ &= E(dB\mu V/m) + 20 \log(D) - 107 \end{aligned}$$

The Transmitted Power @ D = 3 Meters

$$P(dBm) = E(dB\mu V/m) - 97.5$$

ULTRATECH GROUP OF LABS

3000 Bristol Circle, Oakville, Ontario, Canada L6H 6G4
Tel. #: 905-829-1570, Fax. #: 905-829-8050, Email: yhk.ultratech@sympatico.ca, Website: <http://www.ultratech-labs.com>

File #: ICOM27-FTX
June 25, 2001

- Assessed by ITI (UK) Competent Body, NVLAP (USA) Accreditation Body & ACA/AUSTEL (Australia), VCCI (Japan)
- Accredited by Industry Canada (Canada) under ACC-LAB (Europe/Canada MRA and APEC/Canada MRA)
- Recognized/Listed by FCC (USA)
- All test results contained in this engineering test report are traceable to National Institute of Standards and Technology (NIST)

8.4. TRANSIENT FREQUENCY BEHAVIOR

1. Connect the transmitter under tests as shown in the above block diagram
2. Set the signal generator to the assigned frequency and modulate with a 1 kHz tone at ± 12.5 kHz deviation and its output level to be 50 dB below the transmitter rf output at the test receiver end.
3. Set the horizontal sweep rate on the storage scope to 10 milliseconds per division and adjust the display to continuously view the 1000 Hz tone from the Demodulator Output Port (DOP) of the Test Receiver. Adjust the vertical scale amplitude control of the scope to display the 1000 Hz at ± 4 divisions vertical Center at the display.
4. Adjust the scope so it will trigger on an increasing magnitude from the RF trigger signal of the transmitter under test when the transmitter was turned on. Set the controls to store the display.
5. The output at the DOP, due to the change in the ratio of the power between the signal generator input power and transmitter output power will, because of the capture effect of the test receiver, produce a change in display: For the first part of the sweep it will show the 1 kHz test signal. Then once the receiver's demodulator has been captured by the transmitter power, the display will show the frequency difference from the assigned frequency to the actual transmitter frequency versus time. The instant when the 1 kHz test signal is completely suppressed (including any capture time due to phasing) is considered to be t_{on} . The trace should be maintained within the allowed divisions during the period t_1 and t_2 .
6. During the time from the end of t_2 to the beginning of t_3 the frequency difference should not exceed the limits set by the FCC in Part 90.214 and the outlined in the Carrier Frequency Stability sections. The allowed limit is equal to FCC frequency tolerance limits specified in FCC 90.213.
7. Repeat the above steps when the transmitter was turned off for measuring t_3 .

ULTRATECH GROUP OF LABS

3000 Bristol Circle, Oakville, Ontario, Canada L6H 6G4
Tel. #: 905-829-1570, Fax. #: 905-829-8050, Email: yhk.ultratech@sympatico.ca, Website: <http://www.ultratech-labs.com>

File #: ICOM27-FTX
June 25, 2001

- Assessed by ITI (UK) Competent Body, NVLAP (USA) Accreditation Body & ACA/AUSTEL (Australia), VCCI (Japan)
- Accredited by Industry Canada (Canada) under ACC-LAB (Europe/Canada MRA and APEC/Canada MRA)
- Recognized/Listed by FCC (USA)
- *All test results contained in this engineering test report are traceable to National Institute of Standards and Technology (NIST)*