

# ENGINEERING TEST REPORT

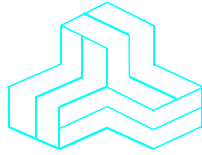

**VHF Air Band Transceiver**  
**Model No.: IC-A110**  
**FCC ID: AFJIC-A110**

*Applicant:*

**ICOM Incorporated**  
1-1-32, Kamiminami, Hirano-ku  
Osaka, Japan, 547-0003

**Tested in Accordance With**

**Federal Communications Commission (FCC)**  
**47 CFR, Parts 2 and 87 (Subpart D) – Aviation Services**

**UltraTech's File No.: ICOM-269F87**

This Test report is Issued under the Authority of  
Tri M. Luu, BASc  
Vice President of Engineering  
UltraTech Group of Labs

Date: February 14, 2011

Report Prepared by: Dan Huynh

Tested by: Wei Wu

Issued Date: February 14, 2011

Test Dates: February 9, 2011

- *The results in this Test Report apply only to the sample(s) tested, and the sample tested is randomly selected.*
- *This report must not be used by the client to claim product endorsement by NVLAP or any agency of the US Government.*

## UltraTech

3000 Bristol Circle, Oakville, Ontario, Canada, L6H 6G4  
Tel.: (905) 829-1570 Fax.: (905) 829-8050  
Website: [www.ultratech-labs.com](http://www.ultratech-labs.com), Email: [vic@ultratech-labs.com](mailto:vic@ultratech-labs.com), Email: [tri@ultratech-labs.com](mailto:tri@ultratech-labs.com)

FCC

91038



1309



Approved Test Facility  
46390-2049



NVLap Lab Code 200093-0



SL2-IN-E-1119R



Korea KCC-RRL  
CA2049

## TABLE OF CONTENTS

<b>EXHIBIT 1.</b>	<b>INTRODUCTION.....</b>	<b>2</b>
1.1.	SCOPE .....	2
1.2.	RELATED SUBMITTAL(S)/GRANT(S).....	2
1.3.	NORMATIVE REFERENCES .....	2
<b>EXHIBIT 2.</b>	<b>PERFORMANCE ASSESSMENT .....</b>	<b>3</b>
2.1.	CLIENT INFORMATION .....	3
2.2.	EQUIPMENT UNDER TEST (EUT) INFORMATION.....	3
2.3.	EUT'S TECHNICAL SPECIFICATIONS .....	4
2.4.	LIST OF EUT'S PORTS .....	4
<b>EXHIBIT 3.</b>	<b>EUT OPERATING CONDITION AND CONFIGURATIONS DURING TESTS.....</b>	<b>5</b>
3.1.	CLIMATE TEST CONDITIONS .....	5
3.2.	OPERATIONAL TEST CONDITIONS & ARRANGEMENT FOR TEST SIGNALS .....	5
<b>EXHIBIT 4.</b>	<b>SUMMARY OF TEST RESULTS.....</b>	<b>6</b>
4.1.	LOCATION OF TESTS .....	6
4.2.	APPLICABILITY & SUMMARY OF EMISSION TEST RESULTS .....	6
4.3.	MODIFICATIONS INCORPORATED IN THE EUT FOR COMPLIANCE PURPOSES .....	6
4.4.	DEVIATION OF STANDARD TEST PROCEDURES .....	6
<b>EXHIBIT 5.</b>	<b>MEASUREMENTS, EXAMINATIONS &amp; TEST DATA FOR EMC EMISSIONS .....</b>	<b>7</b>
5.1.	TEST PROCEDURES.....	7
5.2.	MEASUREMENT UNCERTAINTIES.....	7
5.3.	MEASUREMENT EQUIPMENT USED .....	7
5.4.	ESSENTIAL/PRIMARY FUNCTIONS AS DECLARED BY THE MANUFACTURER .....	7
5.5.	RF POWER OUTPUT [ §§ 2.1046 & 87.131] .....	8
5.6.	OCCUPIED BANDWIDTH AND EMISSION LIMITATIONS [ §§ 2.1049, 87.135 & 87.139].....	9
<b>EXHIBIT 6.</b>	<b>TEST EQUIPMENT LIST .....</b>	<b>16</b>
<b>EXHIBIT 7.</b>	<b>MEASUREMENT UNCERTAINTY.....</b>	<b>17</b>
7.1.	RADIATED EMISSION MEASUREMENT UNCERTAINTY .....	17
<b>EXHIBIT 8.</b>	<b>MEASUREMENT METHODS.....</b>	<b>18</b>
8.1.	CONDUCTED POWER MEASUREMENTS.....	18
8.2.	RADIATED POWER MEASUREMENTS (ERP & EIRP) USING SUBSTITUTION METHOD.....	19
8.3.	FREQUENCY STABILITY .....	22
8.4.	EMISSION LIMITATIONS.....	23
8.5.	SPURIOUS EMISSIONS (CONDUCTED) .....	23

## EXHIBIT 1. INTRODUCTION

### 1.1. SCOPE

<b>Reference:</b>	FCC Parts 2 and 87
<b>Title:</b>	Code of Federal Regulations (CFR), Title 47 Telecommunication – Parts 2 & 87
<b>Purpose of Test:</b>	To obtain FCC Certification Authorization for Radio operating in the frequency band 118-136.975 MHz.
<b>Test Procedures:</b>	Both conducted and radiated emissions measurements were conducted in accordance with TIA/EIA Standard TIA/EIA-603-C – Land Mobile FM or PM Communications Equipment Measurement and performance Standards.

### 1.2. RELATED SUBMITTAL(S)/GRANT(S)

None.

### 1.3. NORMATIVE REFERENCES

Publication	Year	Title
FCC CFR Parts 0-19, 80-End	2009	Code of Federal Regulations – Telecommunication
ANSI C63.4	2009	American National Standard for Methods of Measurement of Radio-Noise Emissions from Low-Voltage Electrical and Electronic Equipment in the Range of 9 kHz to 40 GHz
TIA/EIA 603, Edition C	2004	Land Mobile FM or PM Communications Equipment Measurement and Performance Standards

## EXHIBIT 2. PERFORMANCE ASSESSMENT

### 2.1. CLIENT INFORMATION

APPLICANT	
<b>Name:</b>	Icom Incorporated
<b>Address:</b>	1-1-32, Kamiminami Hirano-ku, Osaka Japan, 547-0003
<b>Contact Person:</b>	Mr. Takayuki Watanabe Phone #: +81 6 6793 5302 Fax #: +81 6 6793 0013 Email Address: <a href="mailto:export@icom.co.jp">export@icom.co.jp</a>

MANUFACTURER	
<b>Name:</b>	Icom Incorporated
<b>Address:</b>	1-1-32, Kamiminami Hirano-ku, Osaka Japan, 547-0003
<b>Contact Person:</b>	Mr. Takayuki Watanabe Phone #: +81 6 6793 5302 Fax #: +81 6 6793 0013 Email Address: <a href="mailto:export@icom.co.jp">export@icom.co.jp</a>

### 2.2. EQUIPMENT UNDER TEST (EUT) INFORMATION

The following information (with the exception of the Date of Receipt) has been supplied by the applicant.

<b>Brand Name:</b>	ICOM Incorporated
<b>Product Name:</b>	VHF Air Band Transceiver
<b>Model Name or Number:</b>	IC-A110
<b>Serial Number:</b>	0528200
<b>External Power Supply:</b>	13.75 V or 27.5 V DC Battery Pack
<b>Transmitting/Receiving Antenna Type:</b>	Non-integral
<b>Type of Equipment:</b>	Non-broadcast Radio Communication Equipment
<b>Primary User Functions of EUT:</b>	VHF air band transceiver for voice communication in occupational environment.

#### ULTRATECH GROUP OF LABS

3000 Bristol Circle, Oakville, Ontario, Canada L6H 6G4  
Tel. #: 905-829-1570, Fax. #: 905-829-8050, Email: [vic@ultratech-labs.com](mailto:vic@ultratech-labs.com), Website: <http://www.ultratech-labs.com>

File #: ICOM-269F87  
February 14, 2011

All test results contained in this engineering test report are traceable to National Institute of Standards and Technology (NIST)

**2.3. EUT’S TECHNICAL SPECIFICATIONS**

<b>TRANSMITTER</b>	
<b>Equipment Type:</b>	Mobile
<b>Intended Operating Environment:</b>	Aviation Services
<b>Power Supply Requirement:</b>	13.75 V or 27.5 V DC Battery
<b>RF Output Power Rating:</b>	9 W Conducted
<b>Operating Frequency Range:</b>	118.00-136.975 MHz
<b>RF Output Impedance:</b>	50 Ω
<b>Channel Spacing:</b>	25.0 kHz, 8.33 kHz
<b>Emission Designation*:</b>	6K00A3E, 5K60A3E
<b>Antenna Connector Type:</b>	J Type

\* For an average case of commercial telephony, the Necessary Bandwidth is calculated as follows:

**Calculation of Necessary Bandwidth for Telephony (Commercial Quality)**

Telephony, double-sideband (single channel):

$B_n = 2M$

Where:  $B_n$  = necessary bandwidth in hertz  
 $M$  = maximum modulation frequency in hertz

$M = 3000\text{Hz}$

$B_n = 2(3000) = 6000 \text{ Hz} = 6.00 \text{ KHz}$

**2.4. LIST OF EUT’S PORTS**

<b>Port Number</b>	<b>EUT’s Port Description</b>	<b>Number of Identical Ports</b>	<b>Connector Type</b>	<b>Cable Type (Shielded/Non-shielded)</b>
1	Microphone	1	RJ45	Shielded
2	Antenna	1	J Type	Terminated to 50 Ω Load
3	External Speaker Jack	1	SP MIC Jack	Non-shielded
4	DC Power Jack	1	Custom 2 pins	Non-shielded
5	Headset Adapter	1	OPC-871	Shielded

**ULTRATECH GROUP OF LABS**

3000 Bristol Circle, Oakville, Ontario, Canada L6H 6G4  
Tel. #: 905-829-1570, Fax. #: 905-829-8050, Email: [vic@ultratech-labs.com](mailto:vic@ultratech-labs.com), Website: <http://www.ultratech-labs.com>

File #: ICOM-269F87  
February 14, 2011

*All test results contained in this engineering test report are traceable to National Institute of Standards and Technology (NIST)*

### EXHIBIT 3. EUT OPERATING CONDITION AND CONFIGURATIONS DURING TESTS

#### 3.1. CLIMATE TEST CONDITIONS

The climate conditions of the test environment are as follows:

Temperature:	21°C
Humidity:	51%
Pressure:	102 kPa
Power input source:	13.75 VDC/27.5 VDC

#### 3.2. OPERATIONAL TEST CONDITIONS & ARRANGEMENT FOR TEST SIGNALS

<b>Operating Modes:</b>	The transmitter was operated in a continuous transmission mode with the carrier modulated as specified in the Test Data.
<b>Special Test Software:</b>	N/A
<b>Special Hardware Used:</b>	None
<b>Transmitter Test Antenna:</b>	The EUT is tested with the transmitter antenna port terminated to a 50 Ω Load.

<b>Transmitter Test Signals</b>	
<b>Frequency Band(s):</b>	118.00-136.975 MHz
<b>Test Frequency(ies):</b> (Near lowest, near middle & near highest frequencies in the frequency range of operation.)	118.01, 127.51 and 136.98 MHz
<b>Transmitter Wanted Output Test Signals:</b>	
▪ RF Power Output (measured maximum output power):	9.23 W
▪ Normal Test Modulation:	AM
▪ Modulating signal source:	External

## EXHIBIT 4. SUMMARY OF TEST RESULTS

### 4.1. LOCATION OF TESTS

All of the measurements described in this report were performed at Ultratech Group of Labs located in the city of Oakville, Province of Ontario, Canada.

Radiated Emissions were performed at the Ultratech's 3-10 TDK Semi-Anechoic Chamber situated in the Town of Oakville, province of Ontario. This test site been calibrated in accordance with ANSI C63.4, and found to be in compliance with the requirements of Sec. 2.948 of the FCC Rules. The descriptions and site measurement data of the Oakville 3-10 TDK Semi-Anechoic Chamber has been filed with FCC office (FCC File No.: 91038) and Industry Canada office (Industry Canada File No.: 2049A-3). Expiry Date: 2011-05-01.

### 4.2. APPLICABILITY & SUMMARY OF EMISSION TEST RESULTS

FCC Section(s)	Test Requirements	Applicability (Yes/No)
2.1046 & 87.131	RF Power Output	Yes
1.1307, 1.1310, 2.1091 & 2.1093	RF Exposure Limit	N/A
2.1047(a) & 87.141(f)	Modulation Characteristics - Audio Frequency Response of Lowpass Filter	N/A
2.1047(b) & 87.141	Modulation Characteristics - Modulation Limiting	N/A
2.1049, 87.135 & 87.139	Occupied Bandwidth and Emission Limitations	Yes
2.1051, 2.1057 & 87.139,	Spurious Emissions at Antenna Terminal	N/A
2.1053, 2.1057 & 87.139	Field Strength of Spurious Emissions	N/A
2.1055 & 87.133	Frequency Stability	N/A

### 4.3. MODIFICATIONS INCORPORATED IN THE EUT FOR COMPLIANCE PURPOSES

None.

### 4.4. DEVIATION OF STANDARD TEST PROCEDURES

None.

---

#### ULTRATECH GROUP OF LABS

3000 Bristol Circle, Oakville, Ontario, Canada L6H 6G4  
Tel. #: 905-829-1570, Fax. #: 905-829-8050, Email: [vic@ultratech-labs.com](mailto:vic@ultratech-labs.com), Website: <http://www.ultratech-labs.com>

File #: ICOM-269F87  
February 14, 2011

All test results contained in this engineering test report are traceable to National Institute of Standards and Technology (NIST)

---

---

## **EXHIBIT 5. MEASUREMENTS, EXAMINATIONS & TEST DATA FOR EMC EMISSIONS**

### **5.1. TEST PROCEDURES**

This section contains test results only. Details of test methods and procedures can be found in Exhibit 8 of this report.

### **5.2. MEASUREMENT UNCERTAINTIES**

The measurement uncertainties stated were calculated in accordance with the requirements of CISPR 16-4-2 @ IEC:2003 and JCGM 100:2008 (GUM 1995) – Guide to the Expression of Uncertainty in Measurement. Refer to Exhibit 7 for Measurement Uncertainties.

### **5.3. MEASUREMENT EQUIPMENT USED**

The measurement equipment used complied with the requirements of the Standards referenced in the Methods & Procedures ANSI C63.4 and CISPR 16-1-1.

### **5.4. ESSENTIAL/PRIMARY FUNCTIONS AS DECLARED BY THE MANUFACTURER**

The essential function of the EUT is to correctly communicate data to and from radios over RF link.



## 5.5. RF POWER OUTPUT [§§ 2.1046 & 87.131]

### 5.5.1. Limits

The following table lists authorized emissions and maximum power. Power must be determined by direct measurement.

Class of station	Frequency band/ frequency	Authorized emission(s) <sup>2</sup>	Maximum power <sup>1</sup>
Aeronautical advisory	VHF	A3E	10 watts <sup>3</sup>
Aeronautical multicom	VHF	A3E	10 watts
Aeronautical search and rescue	VHF	A3E	10 watts
Aeronautical utility mobile	VHF	A3E	10 watts

#### Notes:

- (1) The power is measured at the transmitter output terminals and the type of power is determined according to the emission designator as follows:
  - (i) Mean power (pY) for amplitude modulated emissions and transmitting both sidebands using unmodulated full carrier.
  - (ii) Peak envelope power (pX) for all emission designators other than those referred to in paragraph (i) of this note.
- (2) Excludes automatic link establishment.
- (3) Power is limited to 0.5 watt, but may not exceed 2 watts when station is used in an automatic unattended mode.

### 5.5.2. Method of Measurements

Refer to Exhibit 8, Section 8.1 of this report for measurement details.

### 5.5.3. Test Arrangement

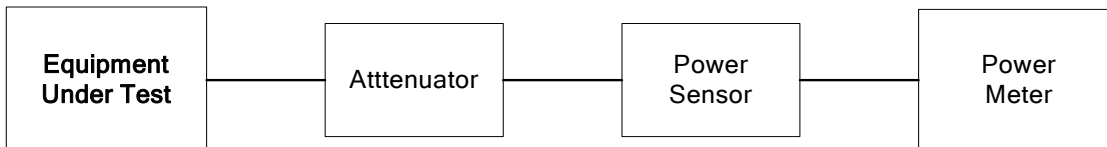

### 5.5.4. Test Data

Input Voltage (VDC)	Transmitter Channel Output	Fundamental Frequency (MHz)	Measured (Average) Power @ Antenna Port (watts)	Maximum Power Limit (watts)
13.75	Lowest	118.01	8.97	10
	Middle	127.51	9.23	10
	Highest	136.98	8.57	10
27.5	Lowest	118.01	8.99	10
	Middle	127.51	9.23	10
	Highest	136.98	8.55	10

#### ULTRATECH GROUP OF LABS

3000 Bristol Circle, Oakville, Ontario, Canada L6H 6G4  
 Tel. #: 905-829-1570, Fax. #: 905-829-8050, Email: [vic@ultratech-labs.com](mailto:vic@ultratech-labs.com), Website: <http://www.ultratech-labs.com>

File #: ICOM-269F87  
 February 14, 2011

All test results contained in this engineering test report are traceable to National Institute of Standards and Technology (NIST)

## 5.6. OCCUPIED BANDWIDTH AND EMISSION LIMITATIONS [§§ 2.1049, 87.135 & 87.139]

### 5.6.1. Limits

§ 87.139(a) - Except for ELTs and when using single sideband (R3E, H3E, J3E), or frequency modulation (F9) or digital modulation (F9Y) for telemetry or telecommand in the frequency bands 1435–1535 MHz and 2310–2390 MHz or digital modulation (G7D) for differential GPS, the mean power of any emission must be attenuated below the mean power of the transmitter (pY) as follows:

- (1) When the frequency is removed from the assigned frequency by more than 50 percent up to and including 100 percent of the authorized bandwidth the attenuation must be at least 25 dB;
- (2) When the frequency is removed from the assigned frequency by more than 100 percent up to and including 250 percent of the authorized bandwidth the attenuation must be at least 35 dB.
- (3) When the frequency is removed from the assigned frequency by more than 250 percent of the authorized bandwidth the attenuation for aircraft station transmitters must be at least 40 dB; and the attenuation for aeronautical station transmitters must be at least  $43 + 10 \log_{10} pY$  dB.

### 5.6.2. Method of Measurements

Refer to Exhibit 8, Section 8.4 of this report for measurement details.

### 5.6.3. Test Arrangement

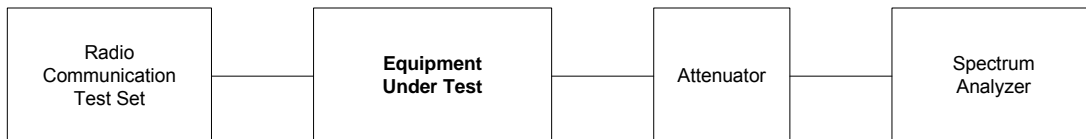

### 5.6.4. Test Data

#### 5.6.4.1. 99% Occupied Bandwidth

Frequency (MHz)	*Measured 99% OBW (kHz)	Authorized Bandwidth (kHz)
118.01	5.29	8.33
127.51	5.33	8.33
136.98	5.33	8.33

\* See the following plots for details of measurements

**Plot 5.6.4.1.1. Occupied Bandwidth for 118.01 MHz**

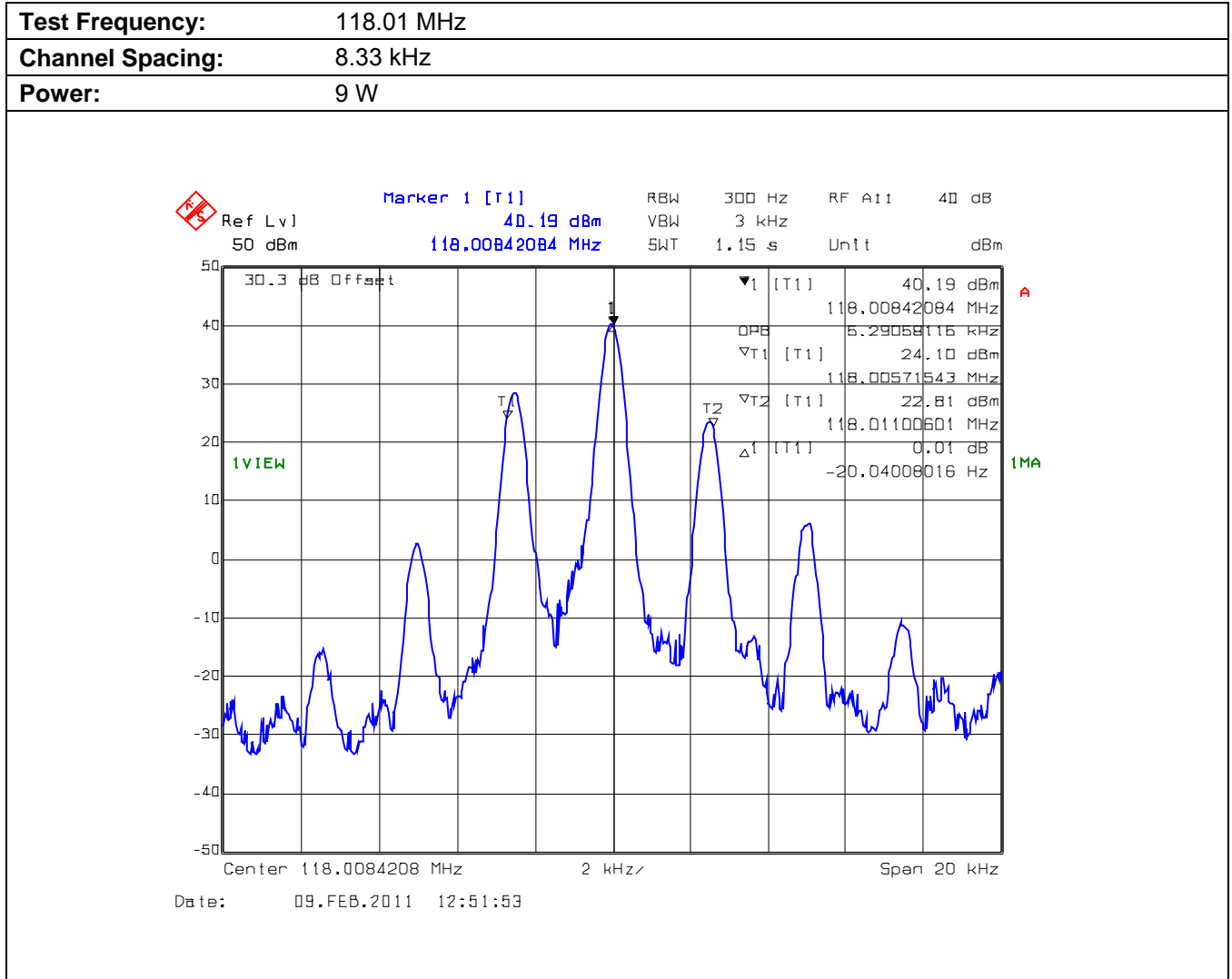

**ULTRATECH GROUP OF LABS**

3000 Bristol Circle, Oakville, Ontario, Canada L6H 6G4  
 Tel. #: 905-829-1570, Fax. #: 905-829-8050, Email: [vic@ultratech-labs.com](mailto:vic@ultratech-labs.com), Website: <http://www.ultratech-labs.com>

**File #: ICOM-269F87**

February 14, 2011

All test results contained in this engineering test report are traceable to National Institute of Standards and Technology (NIST)

Plot 5.6.4.1.2. Occupied Bandwidth for 127.51 MHz

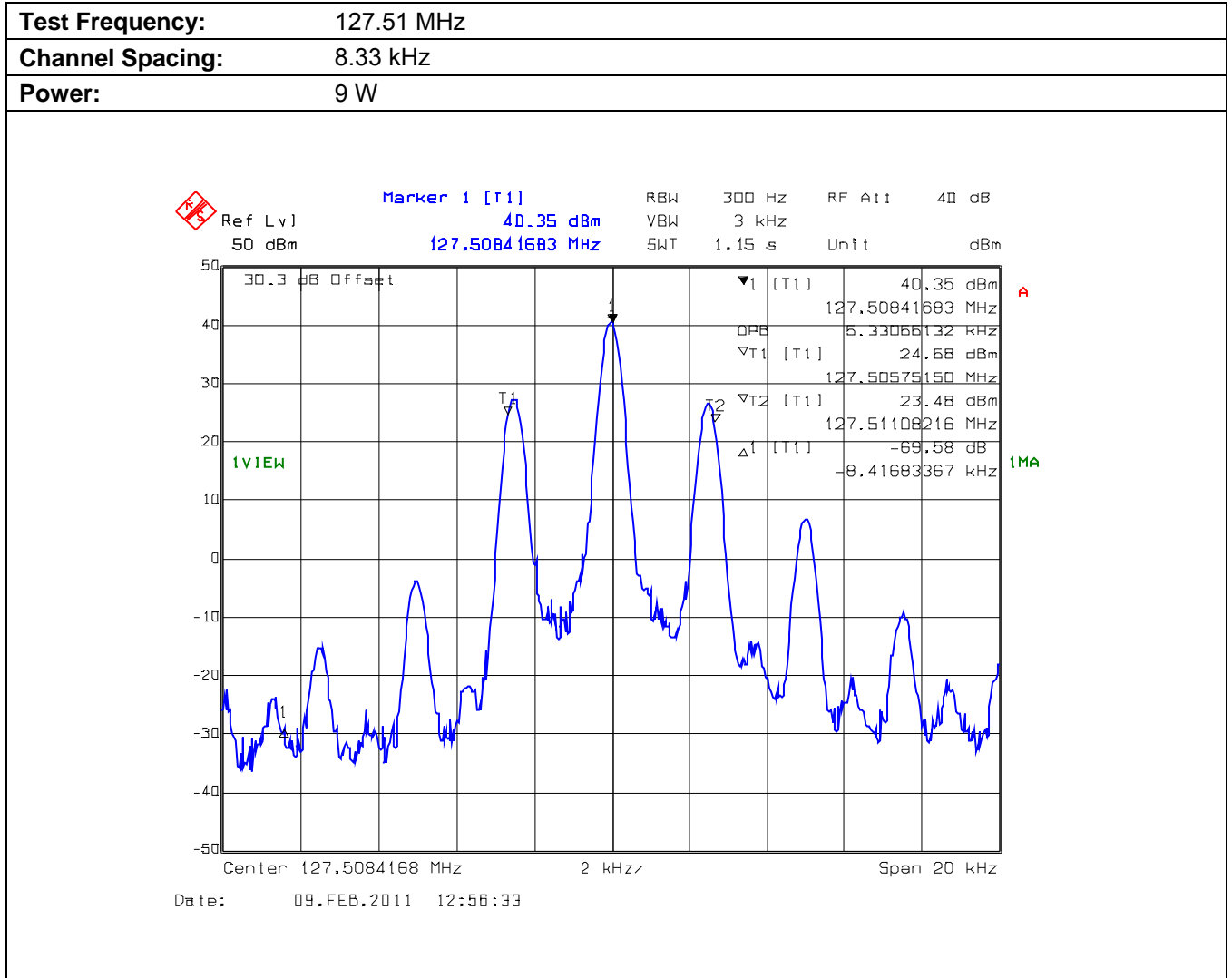

**ULTRATECH GROUP OF LABS**

3000 Bristol Circle, Oakville, Ontario, Canada L6H 6G4  
 Tel. #: 905-829-1570, Fax. #: 905-829-8050, Email: [vic@ultratech-labs.com](mailto:vic@ultratech-labs.com), Website: <http://www.ultratech-labs.com>

File #: ICOM-269F87

February 14, 2011

All test results contained in this engineering test report are traceable to National Institute of Standards and Technology (NIST)

**Plot 5.6.4.1.3. Occupied Bandwidth for 136.98 MHz**

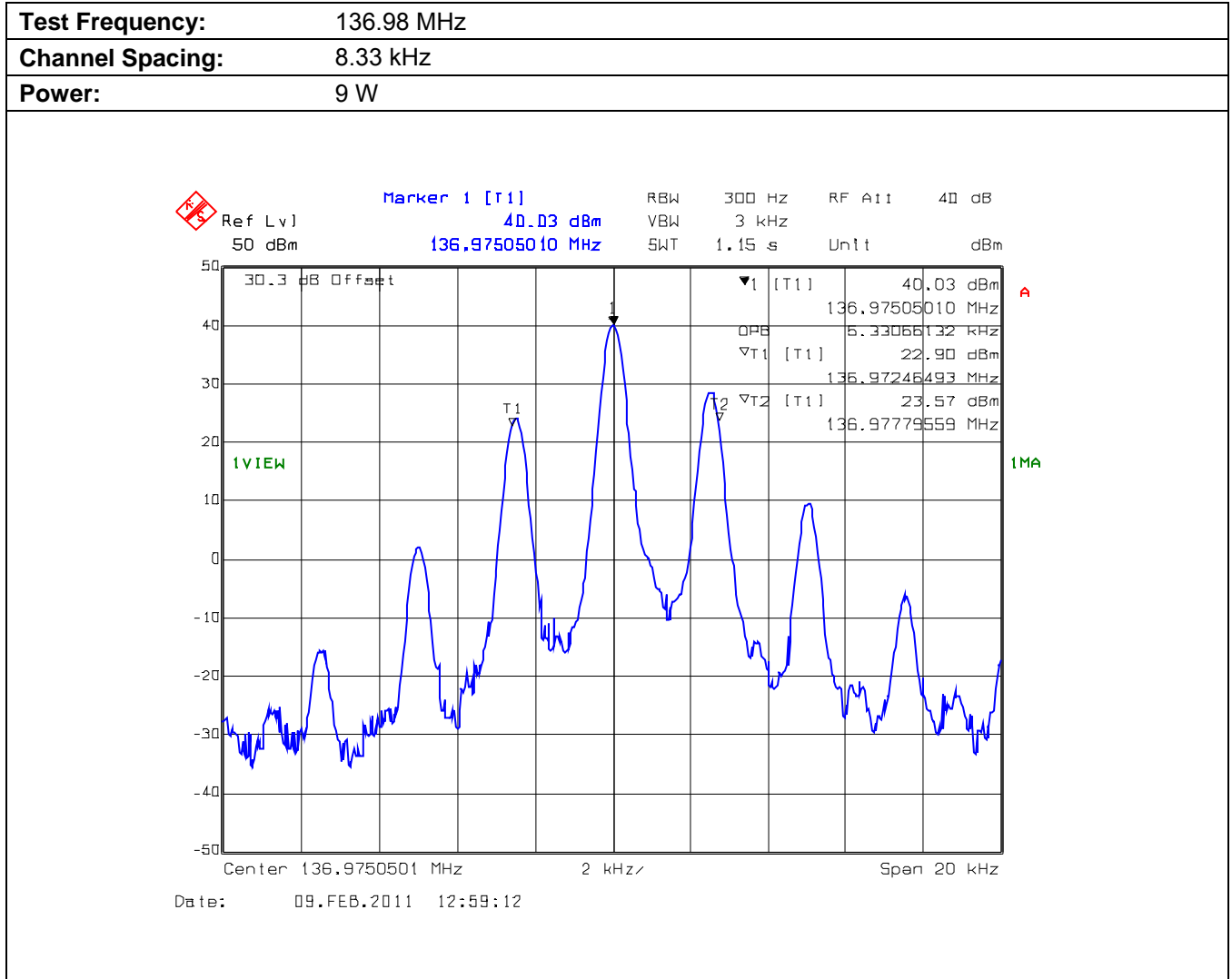

**ULTRATECH GROUP OF LABS**

3000 Bristol Circle, Oakville, Ontario, Canada L6H 6G4  
Tel. #: 905-829-1570, Fax. #: 905-829-8050, Email: [vic@ultratech-labs.com](mailto:vic@ultratech-labs.com), Website: <http://www.ultratech-labs.com>

File #: ICOM-269F87

February 14, 2011

All test results contained in this engineering test report are traceable to National Institute of Standards and Technology (NIST)

5.6.4.2. Emission Limitations

Plot 5.6.4.2.1. Emission Limitation for 118.01 MHz

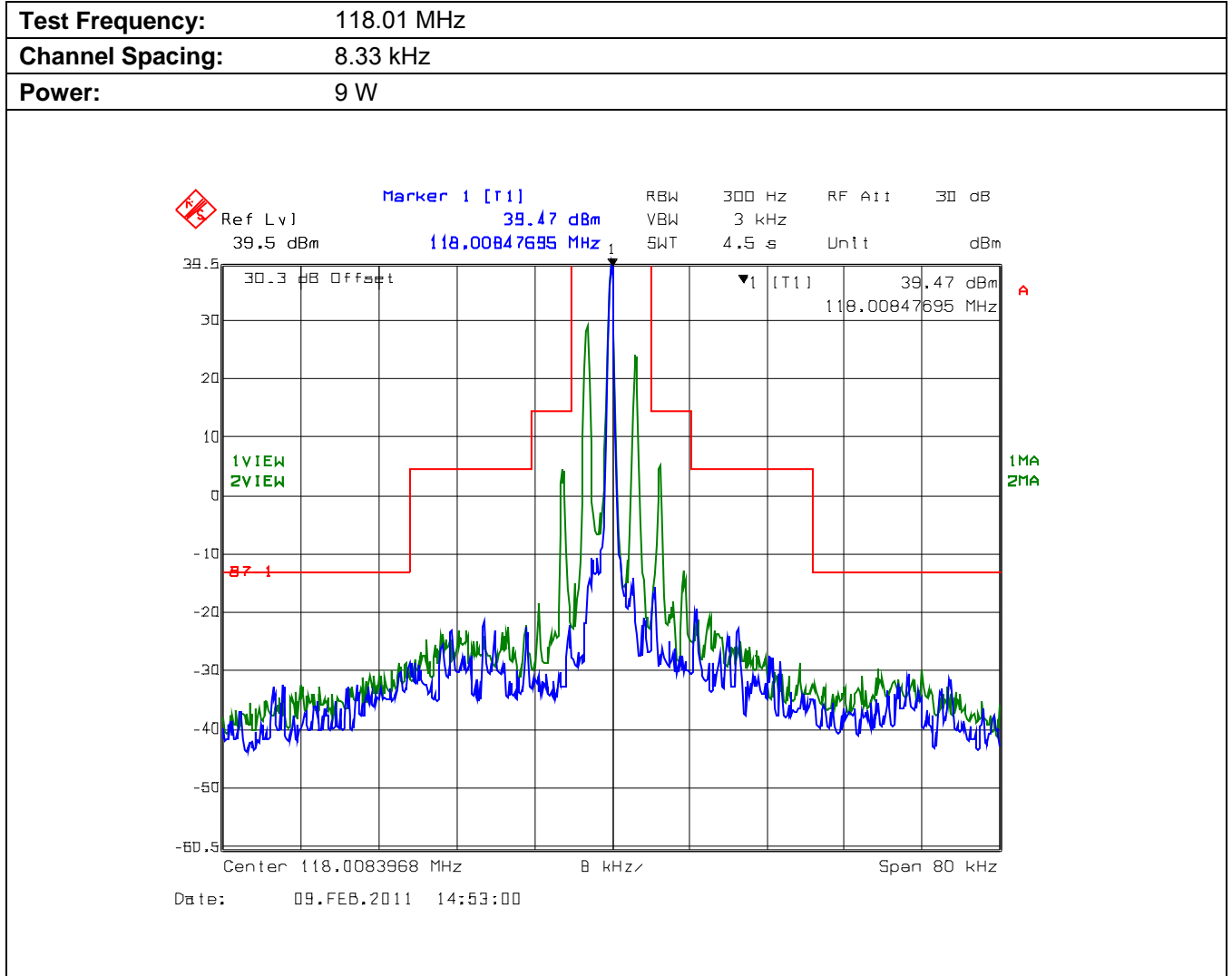

**ULTRATECH GROUP OF LABS**

3000 Bristol Circle, Oakville, Ontario, Canada L6H 6G4  
 Tel. #: 905-829-1570, Fax. #: 905-829-8050, Email: [vic@ultratech-labs.com](mailto:vic@ultratech-labs.com), Website: <http://www.ultratech-labs.com>

File #: ICOM-269F87

February 14, 2011

All test results contained in this engineering test report are traceable to National Institute of Standards and Technology (NIST)

Plot 5.6.4.2.2. Emission Limitation for 127.51 MHz

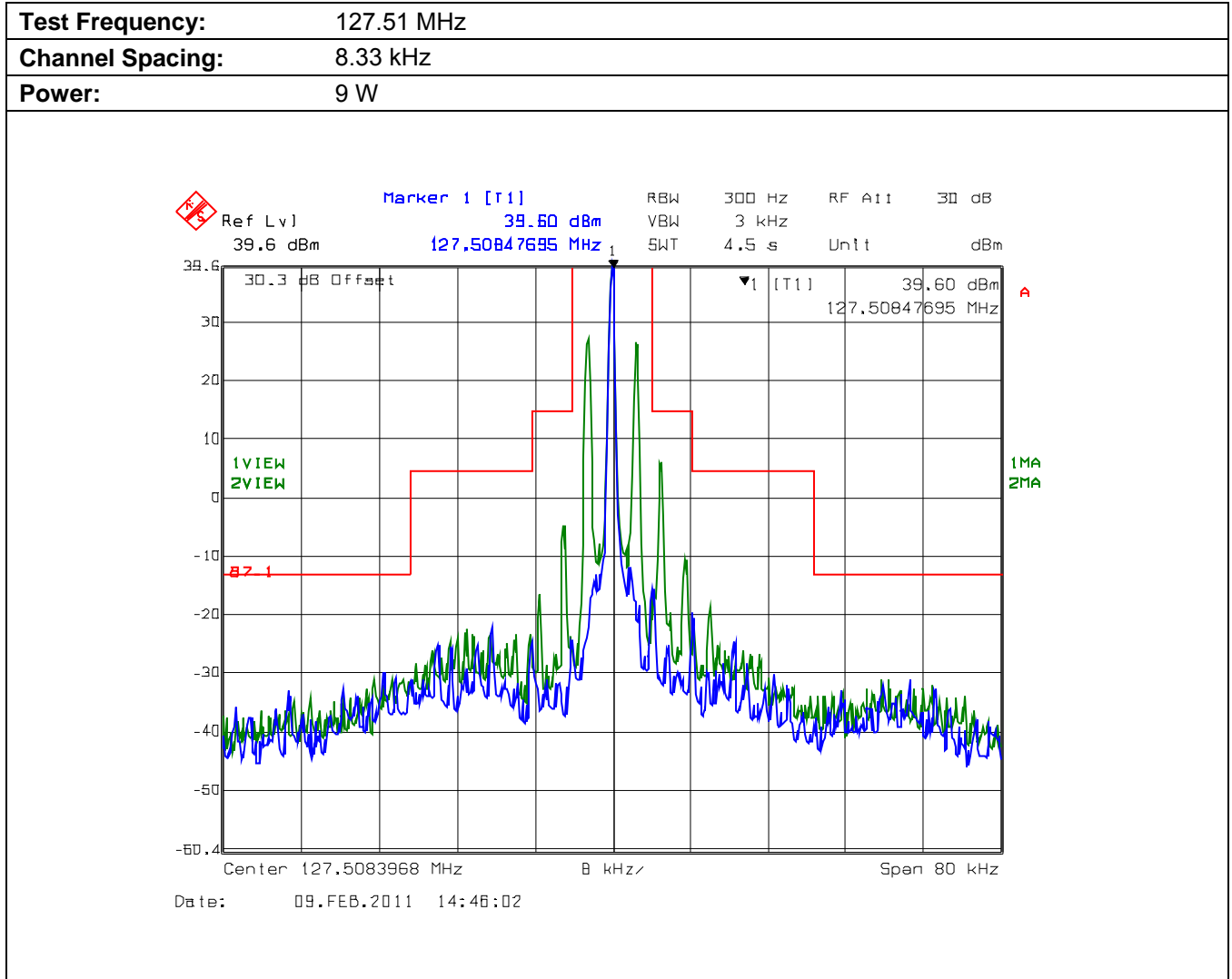

**ULTRATECH GROUP OF LABS**

3000 Bristol Circle, Oakville, Ontario, Canada L6H 6G4  
 Tel. #: 905-829-1570, Fax. #: 905-829-8050, Email: [vic@ultratech-labs.com](mailto:vic@ultratech-labs.com), Website: <http://www.ultratech-labs.com>

File #: ICOM-269F87

February 14, 2011

All test results contained in this engineering test report are traceable to National Institute of Standards and Technology (NIST)

Plot 5.6.4.2.3. Emission Limitation for 136.98 MHz

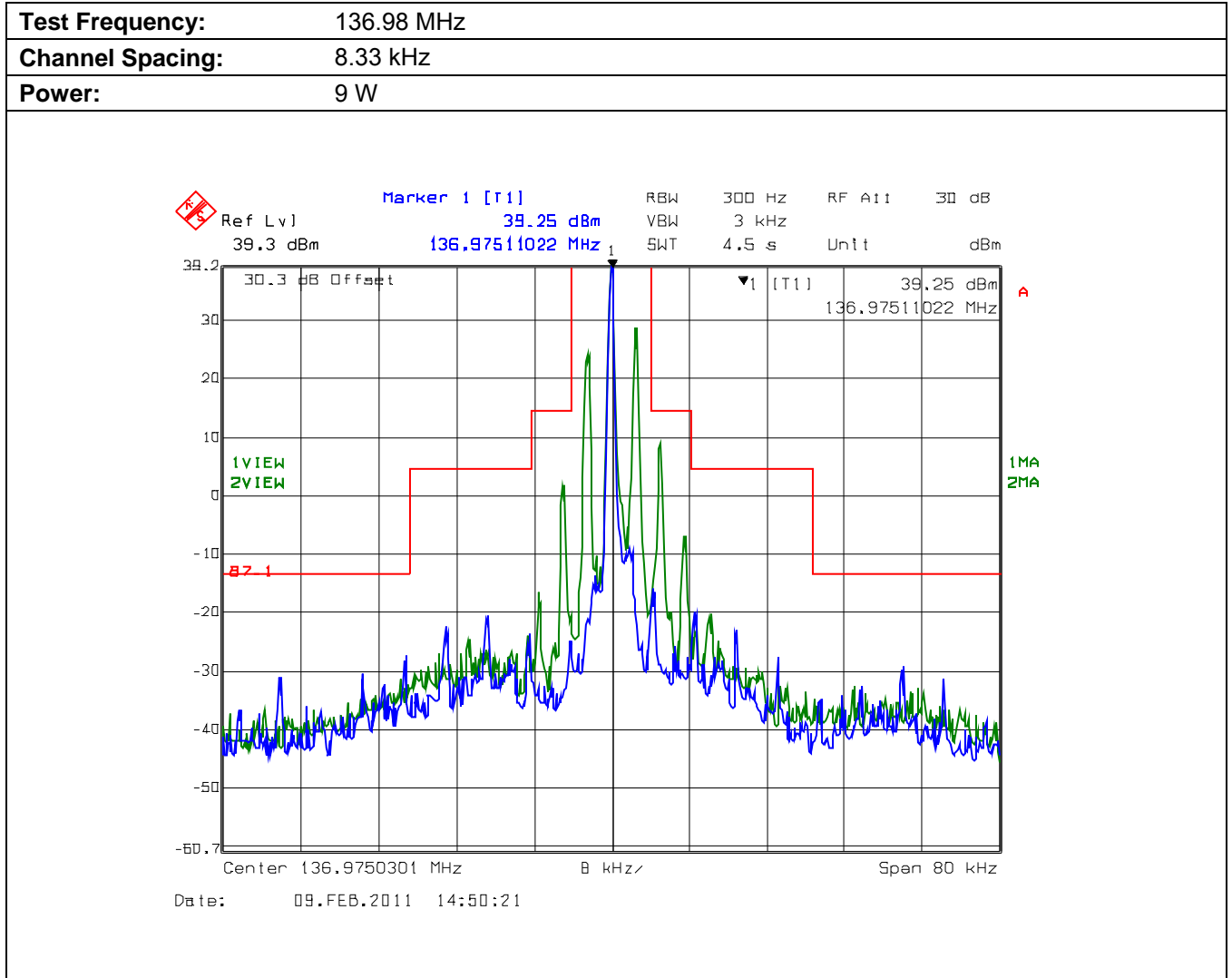

**ULTRATECH GROUP OF LABS**

3000 Bristol Circle, Oakville, Ontario, Canada L6H 6G4  
 Tel. #: 905-829-1570, Fax. #: 905-829-8050, Email: [vic@ultratech-labs.com](mailto:vic@ultratech-labs.com), Website: <http://www.ultratech-labs.com>

File #: ICOM-269F87

February 14, 2011

All test results contained in this engineering test report are traceable to National Institute of Standards and Technology (NIST)



**EXHIBIT 6. TEST EQUIPMENT LIST**

Test Instruments	Manufacturer	Model No.	Serial No.	Frequency Range	Cal. Due Date
Spectrum Analyzer	Rhode & Schwarz	FSEK	834157/005	9 KHz – 40 GHz	26 Jul 2011
Attenuator (30dB)	Aeroflex/Weinschel	46-30-34	BR9127	DC-18 GHz	Cal. on use
Power Meter	Hewlett Packard	437B	3125U06665	100K--50G sensor dependent	20 Aug 2011
Power Sensor	Hewlett Packard	8481A	1550A15143	0.1 - 18 GHz	21 Jul 2011
RF Communication Test Set	Hewlett Packard	8920B	US39064699	30MHz-1GHz	27 Oct 2012

**ULTRATECH GROUP OF LABS**

3000 Bristol Circle, Oakville, Ontario, Canada L6H 6G4  
Tel. #: 905-829-1570, Fax. #: 905-829-8050, Email: [vic@ultratech-labs.com](mailto:vic@ultratech-labs.com), Website: <http://www.ultratech-labs.com>

File #: ICOM-269F87  
February 14, 2011

*All test results contained in this engineering test report are traceable to National Institute of Standards and Technology (NIST)*

## EXHIBIT 7. MEASUREMENT UNCERTAINTY

The measurement uncertainties stated were calculated in accordance with the requirements of CISPR 16-4-2 @ IEC:2003 and JCGM 100:2008 (GUM 1995) – Guide to the Expression of Uncertainty in Measurement.

### 7.1. RADIATED EMISSION MEASUREMENT UNCERTAINTY

	Radiated Emission Measurement Uncertainty @ 3m, Horizontal (30-1000 MHz):	Measured	Limit
$u_c$	<b>Combined standard uncertainty:</b> $u_c(y) = \sqrt{\sum_{i=1}^m u_i^2(y)}$	$\pm 2.15$	$\pm 2.6$
<b>U</b>	<b>Expanded uncertainty U:</b> $U = 2u_c(y)$	$\pm 4.30$	$\pm 5.2$

	Radiated Emission Measurement Uncertainty @ 3m, Vertical (30-1000 MHz):	Measured	Limit
$u_c$	<b>Combined standard uncertainty:</b> $u_c(y) = \sqrt{\sum_{i=1}^m u_i^2(y)}$	$\pm 2.39$	$\pm 2.6$
<b>U</b>	<b>Expanded uncertainty U:</b> $U = 2u_c(y)$	$\pm 4.78$	$\pm 5.2$

	Radiated Emission Measurement Uncertainty @ 3 m, Horizontal & Vertical (1 – 18 GHz):	Measured	Limit
$u_c$	<b>Combined standard uncertainty:</b> $u_c(y) = \sqrt{\sum_{i=1}^m u_i^2(y)}$	$\pm 1.87$	Under consideration
<b>U</b>	<b>Expanded uncertainty U:</b> $U = 2u_c(y)$	$\pm 3.75$	Under consideration

## EXHIBIT 8. MEASUREMENT METHODS

### 8.1. CONDUCTED POWER MEASUREMENTS

- The following shall be applied to the combination(s) of the radio device and its intended antenna(e).
- If the RF level is user adjustable, all measurements shall be made with the highest power level available to the user for that combination.
- The following method of measurement shall apply to both conducted and radiated measurements.
- The radiated measurements are performed at the Ultratech Calibrated Open Field Test Site.
- The measurement shall be performed using normal operation of the equipment with modulation.

Test procedure shall be as follows:

**Step 1:** Duty Cycle measurements if the transmitter's transmission is transient

- Using a EMI Receiver with the frequency span set to 0 Hz and the sweep time set at a suitable value to capture the envelope peaks and the duty cycle of the transmitter output signal;
- The duty cycle of the transmitter,  $x = \text{Tx on} / (\text{Tx on} + \text{Tx off})$  with  $0 < x < 1$ , is measure and recorded in the test report. For the purpose of testing, the equipment shall be operated with a duty cycle that is equal or more than 0.1.

**Step 2:** Calculation of Average EIRP. See Figure 1

- The average output power of the transmitter shall be determined using a wideband, calibrated RF average power meter with the power sensor with an integration period that exceeds the repetition period of the transmitter by a factor 5 or more. The observed value shall be recorded as "A" (in dBm);
- The e.i.r.p. shall be calculated from the above measured power output "A", the observed duty cycle x, and the applicable antenna assembly gain "G" in dBi, according to the formula:

$$\text{EIRP} = \text{A} + \text{G} + 10\log(1/x)$$

{ X = 1 for continuous transmission =>  $10\log(1/x) = 0 \text{ dB}$  }

**Figure 1.**

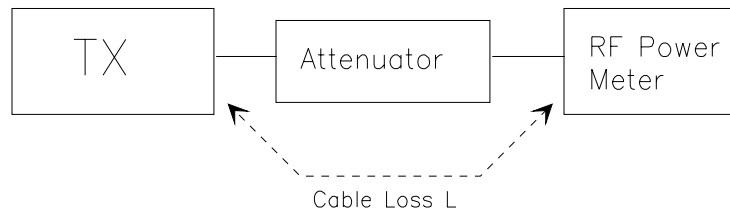

## 8.2. RADIATED POWER MEASUREMENTS (ERP & EIRP) USING SUBSTITUTION METHOD

### 8.2.1. Maximizing RF Emission Level (E-Field)

- (a) The measurements was performed with full rf output power and modulation.
- (b) Test was performed at listed 3m open area test site (listed with FCC, IC, ITI, NVLAP, ACA & VCCI).
- (c) The transmitter under test was placed at the specified height on a non-conducting turntable (80 cm height)
- (d) The BICONILOG antenna (20 MHz to 1 GHz) or HORN antenna (1 GHz to 18 GHz) was used for measuring.
- (e) Load an appropriate correction factors file in EMI Receiver for correcting the field strength reading level

Total Correction Factor recorded in the EMI Receiver = Cable Loss + Antenna Factor  
E (dBuV/m) = Reading (dBuV) + Total Correction Factor (dB/m)

- (f) Set the EMI Receiver and #2 as follows:

Center Frequency: test frequency  
Resolution BW: 100 kHz  
Video BW: same  
Detector Mode: positive  
Average: off  
Span: 3 x the signal bandwidth

- (g) The test antenna was lowered or raised from 1 to 4 meters until the maximum signal level was detected.
- (h) The transmitter was rotated through 360° about a vertical axis until a higher maximum signal was received.
- (i) The test antenna was lowered or raised again from 1 to 4 meters until a maximum was obtained. This level was recorded.
- (j) The recorded reading was corrected to the true field strength level by adding the antenna factor, cable loss and subtracting the pre-amplifier gain.
- (k) The above steps were repeated with both transmitters' antenna and test receiving antenna placed in vertical and horizontal polarization. Both readings with the antennas placed in vertical and horizontal polarization shall be recorded.
- (l) Repeat for all different test signal frequencies

### 8.2.2. Measuring the EIRP of Spurious/Harmonic Emissions Using Substitution Method

(a) Set the EMI Receiver (for measuring E-Field) and Receiver #2 (for measuring EIRP) as follows:

Center Frequency: equal to the signal source  
Resolution BW: 10 kHz  
Video BW: same  
Detector Mode: positive  
Average: off  
Span: 3 x the signal bandwidth

(b) Load an appropriate correction factors file in EMI Receiver for correcting the field strength reading level

Total Correction Factor recorded in the EMI Receiver = Cable Loss + Antenna Factor  
 $E \text{ (dBuV/m)} = \text{Reading (dBuV)} + \text{Total Correction Factor (dB/m)}$

(c) Select the frequency and E-field levels obtained in the Section 8.2.1 for ERP/EIRP measurements.

(d) Substitute the EUT by a signal generator and one of the following transmitting antenna (substitution antenna):

- ◆ DIPOLE antenna for frequency from 30-1000 MHz or
- ◆ HORN antenna for frequency above 1 GHz }.

(e) Mount the transmitting antenna at 1.5 meter high from the ground plane.

(f) Use one of the following antenna as a receiving antenna:

- ◆ DIPOLE antenna for frequency from 30-1000 MHz or
- ◆ HORN antenna for frequency above 1 GHz }.

(g) If the DIPOLE antenna is used, tune it's elements to the frequency as specified in the calibration manual.

(h) Adjust both transmitting and receiving antenna in a VERTICAL polarization.

(i) Tune the EMI Receivers to the test frequency.

(j) Lower or raise the test antenna from 1 to 4 meters until the maximum signal level was detected.

(k) The transmitter was rotated through 360° about a vertical axis until a higher maximum signal was received.

(l) Lower or raise the test antenna from 1 to 4 meters until the maximum signal level was detected.

(m) Adjust input signal to the substitution antenna until an equal or a known related level to that detected from the transmitter was obtained in the test receiver.

(n) Record the power level read from the Average Power Meter and calculate the ERP/EIRP as follows:

$$P = P1 - L1 = (P2 + L2) - L1 = P3 + A + L2 - L1$$

$$\text{EIRP} = P + G1 = P3 + L2 - L1 + A + G1$$

$$\text{ERP} = \text{EIRP} - 2.15 \text{ dB}$$

$$\text{Total Correction factor in EMI Receiver \# 2} = L2 - L1 + G1$$

Where: P: Actual RF Power fed into the substitution antenna port after corrected.

P1: Power output from the signal generator

P2: Power measured at attenuator A input

P3: Power reading on the Average Power Meter

EIRP: EIRP after correction

ERP: ERP after correction

(o) Adjust both transmitting and receiving antenna in a HORIZONTAL polarization, then repeat step (k) to (o)

(p) Repeat step (d) to (o) for different test frequency

(q) Repeat steps (c) to (j) with the substitution antenna oriented in horizontal polarization.

(r) Actual gain of the EUT's antenna is the difference of the measured EIRP and measured RF power at the RF port. Correct the antenna gain if necessary.

Figure 2

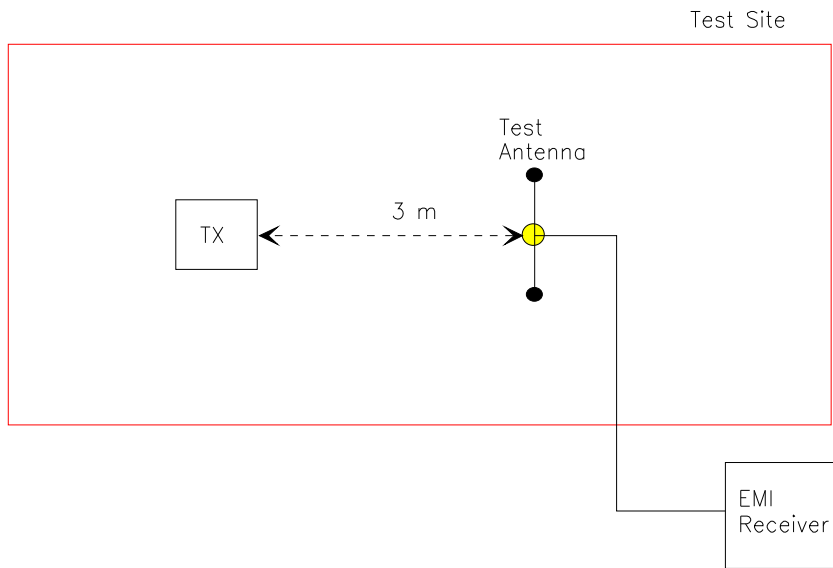
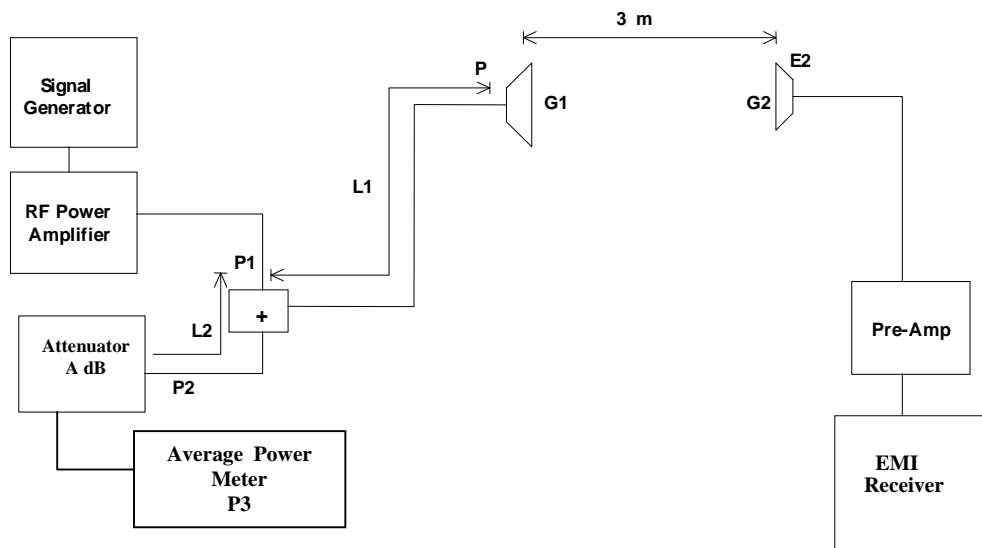

Figure 3



### 8.3. FREQUENCY STABILITY

Refer to FCC @ 2.1055.

- (a) The frequency stability shall be measured with variation of ambient temperature as follows: From -30 to +50 centigrade except that specified in subparagraph (2) & (3) of this paragraph.
- (b) Frequency measurements shall be made at extremes of the specified temperature range and at intervals of not more than 10 centigrade through the range. A period of time sufficient to stabilize all of the components of the oscillator circuit at each temperature level shall be allowed prior to frequency measurement. The short-term transient effects on the frequency of the transmitter due to keying (except for broadcast transmitters) and any heating element cycling normally occurring at each ambient temperature level also shall be shown. Only the portion or portions of the transmitter containing the frequency determining and stability circuitry need be subjected to the temperature variation test.
- (d) The frequency stability supply shall be measured with variation of primary supply voltage as follows:
  - (1) Vary primary supply voltage from 85 to 115 percent of the nominal value for other than hand carried battery equipment.
  - (2) For hand carried, battery powered equipment, reduce primary supply voltage to the battery operating end point which shall be specified by the manufacturer.
  - (3) The supply voltage shall be measured at the input to the cable normally provide with the equipment, or at the power supply terminals if cables are not normally provided. Effects on frequency of transmitter keying (except for broadcast transmitters) and any heating element cycling at the nominal supply voltage and at each extreme also shall be shown.
- (e) When deemed necessary, the Commission may require tests of frequency stability under conditions in addition to those specifically set out in paragraphs (a), (b), (c) and (d) of this section. (For example, measurements showing the effect of proximity to large metal objects, or of various types of antennas, may be required for portable equipment).

## 8.4. EMISSION LIMITATIONS

**Voice or Digital Modulation Through a Voice Input Port @ 2.1049(c)(i):**- The transmitter was modulated by a 2.5 KHz tone signal at an input level 16 dB greater than that required to produce 50% modulation (e.g.:  $\pm 2.5$  KHz peak deviation at 1 KHz modulating frequency). The input level was established at the frequency of maximum response of the audio modulating circuit.

**Digital Modulation Through a Data Input Port @ 2.1049(h):**- Transmitters employing digital modulation techniques - when modulated by an input signal such that its amplitude and symbol rate represent the maximum rated conditions under which the equipment will be operated. The signal shall be applied through any filter networks, pseudo-random generators or other devices required in normal service. Additionally, the Emission Masks shall be shown for operation with any devices used for modifying the spectrum when such devices are operational at the discretion of the user.

The following EMI Receiver bandwidth shall be used for measurement of Emission Mask/Out-of-Band Emission Measurements:

- (1) For 25 kHz Channel Spacing: RBW = 300 Hz
- (2) For 12.5 kHz or 6.25 kHz Channel Spacings: RBW = 100 Hz

The all cases the Video Bandwidth shall be equal or greater than the measuring bandwidth.

## 8.5. SPURIOUS EMISSIONS (CONDUCTED)

With transmitter modulation characteristics described in Out-of-Band Emissions measurements @ 2.1049, the transmitter spurious and harmonic emissions were scanned. The spurious and harmonic emissions were measured with the EMI Receiver controls set as RBW = 30 kHz minimum , VBW  $\geq$  RBW and SWEEP TIME = AUTO). The transmitter was operated at a full rated power output, and modulated as follows:

**FCC CFR 47, Para. 2.1057 - Frequency spectrum to be investigated:-** The spectrum was investigated from the lowest radio generated in the equipment up to at least the 10<sup>th</sup> harmonic of the carrier frequency or to the highest frequency practicable in the present state of the art of measuring techniques, whichever is lower. Particular attention should be paid to harmonics and subharmonics of the carrier frequency. Radiation at the frequencies of multiplier stages should be checked. The amplitude of spurious emissions which are attenuated more than 20 dB below the permissible value need not be reported.

**FCC CFR 47, Para. 2.1051 - Spurious Emissions at Antenna Terminal:-** The radio frequency voltage or powers generated within the equipment and appearing on a spurious frequency shall be checked at the equipment output terminals when properly loaded with a suitable artificial antenna. Curves or equivalent data shall show the magnitude of the harmonic and other spurious emission that can be detected when the equipment is operated under the conditions specified in 2.1049 as appropriate. The magnitude of spurious emissions which are attenuated more than 20 dB below the permissible value need not be specified.