

Test System-Arrangement (Drawings)

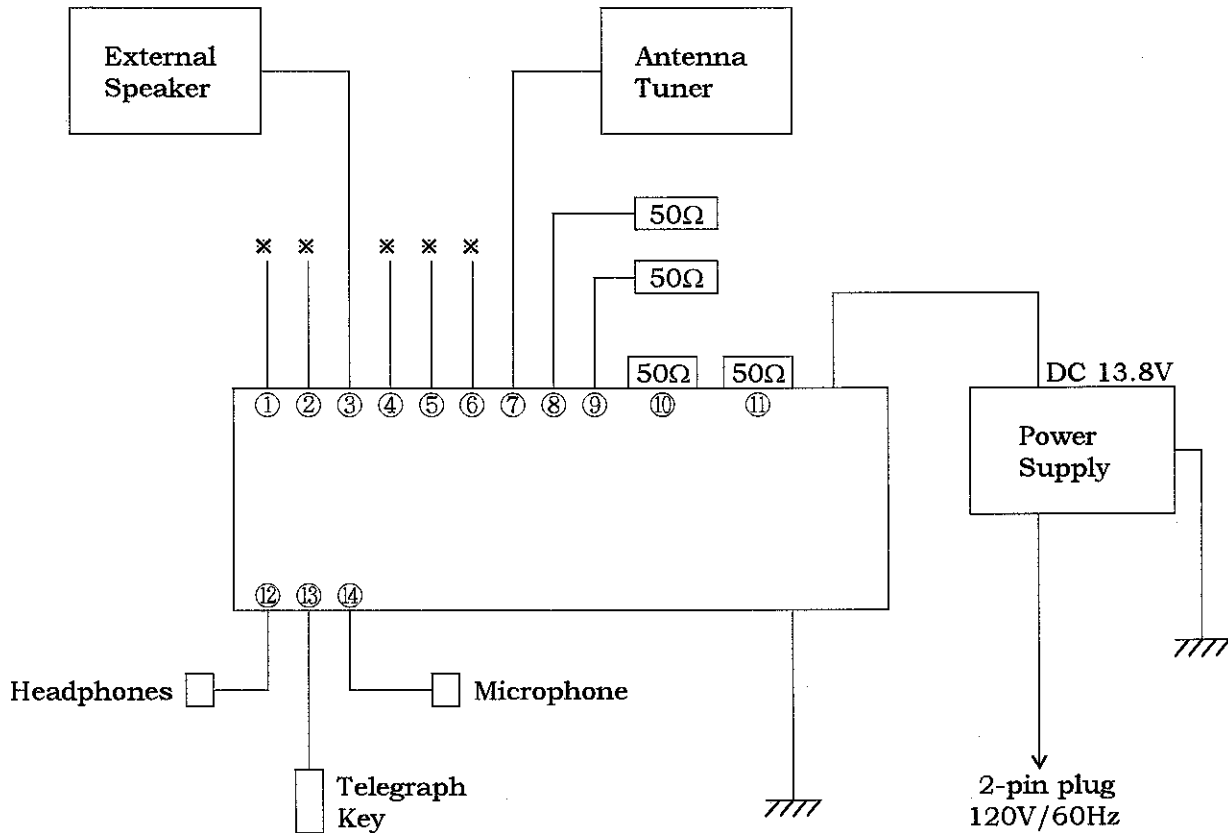

Note)

* - No termination

- | | |
|------------|--------------|
| ① - SEND | ⑧ - RX ANT |
| ② - ALC | ⑨ - X-VERTER |
| ③ - EXT SP | ⑩ - ANT 1 |
| ④ - REMOTE | ⑪ - ANT 2 |
| ⑤ - ACC(1) | ⑫ - PHONES |
| ⑥ - ACC(2) | ⑬ - ELEC-KEY |
| ⑦ - TUNER | ⑭ - MIC |

Preliminary Test and Test-setup(Drawings)

AC Powerline Conducted Emission 450 kHz - 30 MHz:

The preliminary test was performed according to the description of ANSI C63.4-1992 Sec.7.2.3 (Preliminary AC Powerline Conducted Emissions Tests) and Sec.6.2.1 (Tabletop Equipment Tests).

The preliminary test was carried out to investigate the frequency of the emission that has the highest amplitude relative to the limits within normal operating modes, cable positions, and a typical system configuration. In order to find out to the maximum emission, the preliminary test and a final test were performed in accordance with the following steps.

Step 1: One operation mode of the test system was setting.

Step 2: Using both of a spectrum analyzer and a test receiver, the emission's circumstance from the system was monitored in one of ten divided frequency bands of the specified frequency range (450 kHz - 30 MHz). The maximum emission in the band was found by changing the typical cable positions or cable manipulation under a typical system configuration and by selecting of current-carrying conductor. The level and the frequency at the one point which are regarded as relative high emission in the band was measured and recorded. This step was repeated until the ending frequency band.

Step 3: Return to step 1, if the other operation mode was possible to be setting.

Step 4: Based on the collected results, the operation mode produced the maximum emission was selected. The final test on the selected operation mode was performed. But if it was difficult to select the operation mode, the final tests on all operation modes were performed.

Step 5: Based on the same data, as result if the final measurement, at the worst point that has the highest amplitude relative to the limit the repeatability of the worst was reconfirmed.

The photographs of the test system setup on the worst point were taken and recorded.

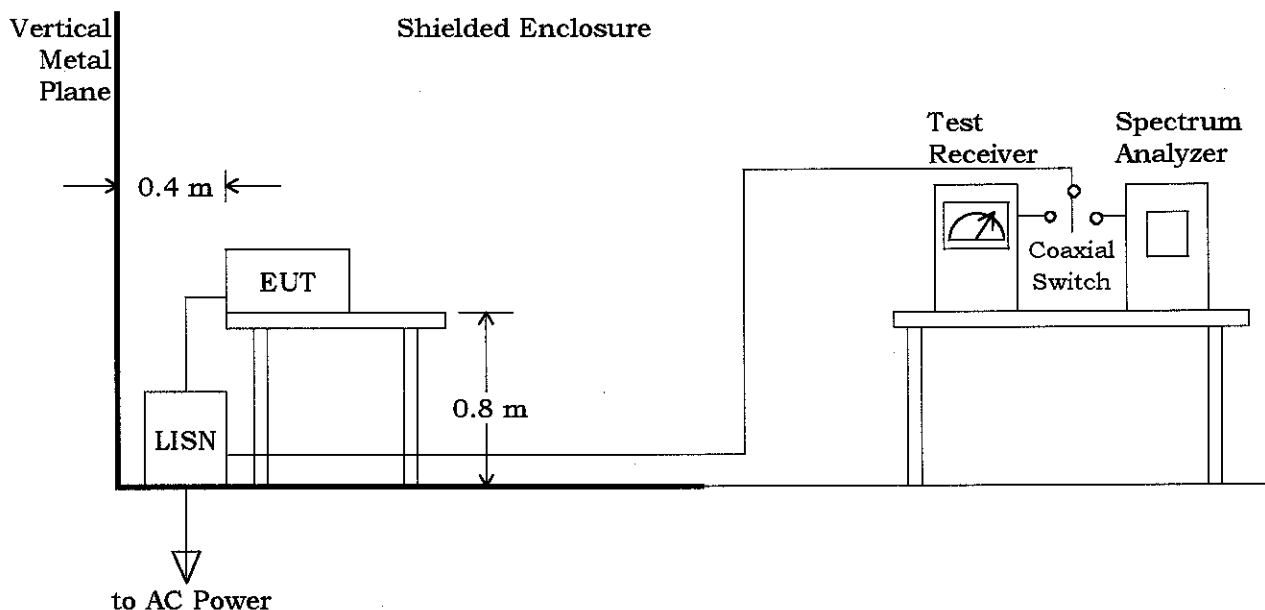

Electromagnetic Field Radiated Emission 30 MHz - 1000 MHz:

The preliminary test was performed according to the description of ANSI C63.4-1992 Sec.8.3.1.1 (Preliminary Radiated Emissions Tests) and Sec.6.2.1 (Tabletop Equipment Tests).

The preliminary test was carried out to investigate the frequency of the emission that has the highest amplitude relative to the limits within normal operating modes, cable positions, and a typical system configuration. In order to find out to the maximum emission, the preliminary test and a final test were performed in accordance with the following steps.

Step 1: One operation mode of the test system was setting.

Step 2: Using a test receiver and a test antenna probe, the significant frequency of the emission's circumstance from the test system were investigated. These data were recorded every one of 22 divided bands in the specified frequency band (30 MHz - 1000 MHz).

Step 3: Using a test receiver and a resonant tuned dipole antenna, the emission's circumstance from the test system was measured in according with ANSI C63.4-1992 Sec.8.3.1.2 (Final Radiated Emissions Tests) at each frequency which was found the higher emission referred to level vs. frequency on the list and which was measured by the resonant tuned dipole antenna. The maximum emission was found by changing the cable positions or cable manipulation under a typical system configuration.

Step 4: Return to step 1, if the other operation mode was possible to be setting.

Step 5: The worst result was reported arranging data of which was obtained and performed by one or plural operation modes as the final test.

At the worst point that has the highest amplitude relative to the limit the repeatability of the level was reconfirmed. The photographs of the tests system setup on the worst point were taken and recorded.

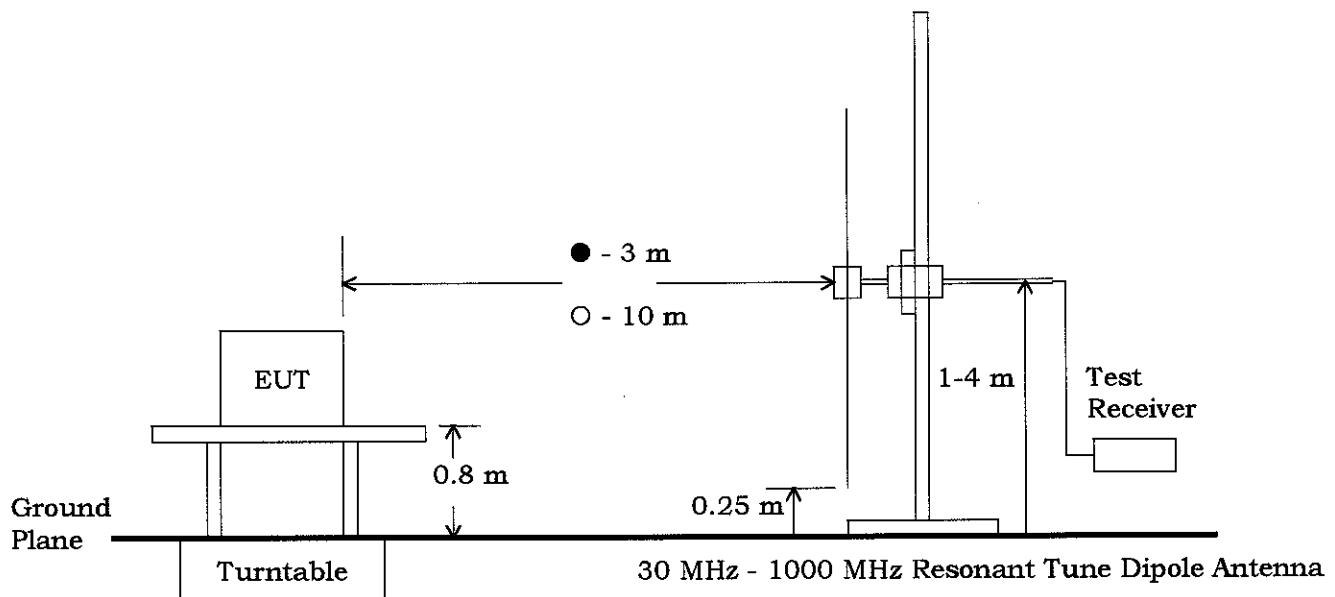

Antenna-Conducted Power 30 MHz - 1000 MHz:

The test was performed according to the description of ANSI C63.4-1992 Sec.12.1.5 (Antenna-Conducted Power Measurements).



Test-Setup (Photographs) at worst case

Conducted Emission 450kHz - 30MHz:



Front View

Radiated Emission 30MHz - 1000MHz:



Front View

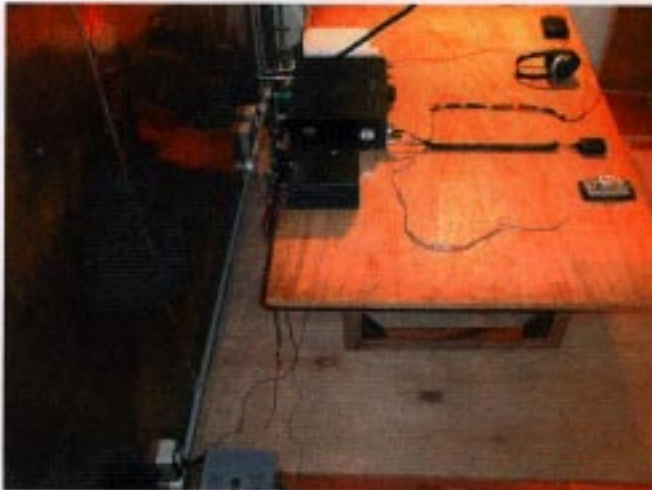

Side View



Rear View