

## FCC IC Test Report (Collocation)

**Report No.:** FCC\_IC\_SL19041701-SEV-040\_Collocation\_Rev1.0

**FCC ID** AFJ382500

**IC** 202D-382500

**Test Model:** IP501M

**Received Date:** 06/21/2019

**Test Date:** 07/08/2019

**Issued Date:** 08/15/2019

**FCC Applicant:** ICOM Incorporated

**Address:** 1-1-32 Kamiminami Hirano-ku Osaka 547-0003 Japan

**FCC Manufacturer:** ICOM Incorporated

**Address:** 1-1-32 Kamiminami Hirano-ku Osaka 547-0003 Japan

**IC Applicant:** ICOM CANADA

**Address:** 150-6165 Highway 17, Glenwood Ctr., Delta BC V4K5B8  
Canada

**IC Manufacturer:** ICOM CANADA

**Address:** 150-6165 Highway 17, Glenwood Ctr., Delta BC V4K5B8  
Canada

**Issued By:** Bureau Veritas Consumer Products Services, Inc.

**Lab Address:** 775 Montague Expressway, Milpitas, CA 95035

**FCC Registration /** 540430

**Designation Number:**

**ISED# / CAB** 4842D  
**identifier:**



This report is for your exclusive use. Any copying or replication of this report to or for any other person or entity, or use of our name or trademark, is permitted only with our prior written permission. This report sets forth our findings solely with respect to the test samples identified herein. The results set forth in this report are not indicative or representative of the quality or characteristics of the lot from which a test sample was taken or any similar or identical product unless specifically and expressly noted. Our report includes all of the tests requested by you and the results thereof based upon the information that you provided to us. You have 60 days from date of issuance of this report to notify us of any material error or omission caused by our negligence, provided, however, that such notice shall be in writing and shall specifically address the issue you wish to raise. A failure to raise such issue within the prescribed time shall constitute your unqualified acceptance of the completeness of this report, the tests conducted and the correctness of the report contents. Unless specific mention, the uncertainty of measurement has been explicitly taken into account to declare the compliance or non-compliance to the specification. The report must not be used by the client to claim product certification, approval, or endorsement by A2LA or any government agencies.

## Table of Contents

<b>Release Control Record</b> .....	<b>3</b>
<b>1 Certificate of Conformity</b> .....	<b>4</b>
<b>2 Summary of Test Results</b> .....	<b>5</b>
2.1 Measurement Uncertainty.....	5
2.2 Modification Record.....	5
2.3 Test Instruments.....	6
<b>3 General Information</b> .....	<b>7</b>
3.1 General Description of EUT.....	7
3.1.1 Test Mode Applicability.....	8
3.2 Description of Support Units.....	8
3.2.1 Configuration of System under Test.....	8
3.3 General Description of Applied Standards.....	9
<b>4 Test Types and Results</b> .....	<b>10</b>
4.1 Radiated Emission and Bandedge Measurement.....	10
4.1.1 Limits of Radiated Emission and Bandedge Measurement.....	10
4.1.2 Test Instruments.....	10
4.1.3 Test Procedures.....	10
4.1.4 Deviation from Test Standard.....	11
4.1.5 Test Setup.....	12
4.1.6 EUT Operating Conditions.....	12
4.1.7 Test Results.....	13
<b>Appendix – Information of the Testing Laboratories</b> .....	<b>15</b>

### Release Control Record

Issue No.	Description	Date Issued
FCC_IC_SL19041701-SEV-040_Collocation	Original Release	07/19/2019
FCC_IC_SL19041701-SEV-040_Collocation_Rev1.0	Updated as per reviewer's comments	08/15/2019

## 1 Certificate of Conformity

**Product:** IP Advanced Radio System

**Brand:** Icom

**Test Model:** IP501M

**Sample Status:** ENGINEERING SAMPLE

**FCC Applicant:** ICOM Incorporated

**IC Applicant:** ICOM CANADA

**Test Date:** 06/21/2019 – 06/23/2019

**Standards:** 47 CFR FCC Part 15, Subpart C (Section 15.247)  
ANSI C63.10: 2013  
RSS 247 Issue 2, February 2017

The above equipment has been tested by **by Bureau Veritas Consumer Products Services, Inc., Milpitas Branch**, and found compliance with the requirement of the above standards. The test record, data evaluation & Equipment Under Test (EUT) configurations represented herein are true and accurate accounts of the measurements of the sample's EMC characteristics under the conditions specified in this report.

**Prepared by :** , **Date:** 08/15/2019  
Rachana Khanduri / Test Engineer

**Approved by :** , **Date:** 08/15/2019  
Chen Ge / Engineer Reviewer

## 2 Summary of Test Results

47 CFR FCC 15.247, RSS 247 Issue 2, February 2017			
FCC IC Clause	Test Item	Result	Remarks
15.207 RSS Gen 8.8	AC Power Conducted Emission	PASS	Pass*
15.205 & 209 & 15.247(d) RSS247(5.5)	Radiated Emissions & Band Edge Measurement	PASS	Meet the requirement of limit.

### NOTE:

- Note: Pass\*: Only radiated spurious emission is tested in this report, for other test items please refer to the RF reports for module UT-133. FCC ID: AFJ356100, IC: 202D-356100 (FCC Report No: 10171657H-A-R1, IC Report No: 10171657H-B-R1).
- Co-location was evaluated as per the worst case configuration. Co-location evaluation includes technology operating under the following rule parts: 47CFR Part 22/24/27 and RSS-130 Issue 2, RSS-132 Issue 3, RSS-133 Issue 6, RSS-139 Issue 3.

### Test Condition:

Test Item	Environmental Conditions	Input Power	Tested By
Radiated Emission	22deg. C, 71%RH	13.8VDC	Rachana Khanduri

### 2.1 Measurement Uncertainty

Where relevant, the following measurement uncertainty levels have been estimated for tests performed on the EUT as specified in CISPR 16-4-2:

Measurement	Frequency	Expanded Uncertainty (k=2) (±)
Conducted Emissions at mains ports	150kHz ~ 30MHz	3.51dB
Radiated Emissions up to 1 GHz	30MHz ~ 1GHz	3.73dB
Radiated Emissions above 1 GHz	1GHz ~ 6GHz	4.64dB
	6GHz ~ 18GHz	4.82dB
	18GHz ~ 40GHz	4.91dB

### 2.2 Modification Record

There were no modifications required for compliance.

### 2.3 Test Instruments

DESCRIPTION & MANUFACTURER	MODEL NO.	SERIAL NO.	DATE OF CALIBRATION	DUE DATE OF CALIBRATION
EMI Test Receiver ROHDE & SCHWARZ	ESIB 40	100179	08/28/2018	08/28/2019
Spectrum Analyzer KEYSIGHT	N9030B	MY57140374	07/22/2018	07/22/2019
Hybrid Antenna SUNAR	JB6	A111717	03/09/2019	03/09/2020
DRG Horn Antenna ETS LINDGREN	3117	214309	11/22/2018	11/22/2019
Horn Antenna EMCO	3115	100059	01/26/2018	01/26/2020
Tuned Dipole Antenna COM-POWER	AD-100	40133	01/23/2018	01/23/2020
Preamplifier RF-LAMBDA	RAMP00M50GA	17032300047	09/19/2018	09/19/2019
Preamplifier RF-BAY	LPA-6-30	11170601	07/24/2018	07/24/2019
Signal Generator KEYSIGHT	N5182A	MY47071065	08/10/2018	08/10/2019

### 3 General Information

#### 3.1 General Description of EUT

Product	IP Advanced Radio System	
Brand	Icom	
Test Model	IP501M	
Serial No.	000000000300	
Serial Mode	N/A	
Model Difference	N/A	
HVIN	382500-01	
Status of EUT	ENGINEERING SAMPLE	
Power Supply Rating	13.8VDC	
Equipment Class/ Category	PCB	
Modulation Type	BT	GFSK, $\pi/4$ -DQPSK, 8DPSK
	WCDMA	QPSK
	LTE	QPSK, 16QAM, 64QAM
Frequency Range	BT	2402MHz ~ 2480MHz
	WCDMA Band 2	TX: 1850 MHz to 1910 MHz RX: 1930 MHz to 1990 MHz
	WCDMA Band 5	TX: 824 MHz to 849 MHz RX: 869 MHz to 894 MHz
	LTE Band 2	TX: 1850 MHz to 1910 MHz RX: 1930 MHz to 1990 MHz
	LTE Band 4	TX: 1710 MHz to 1755 MHz RX: 2110 MHz to 2155 MHz
	LTE Band 12	TX: 699 MHz to 716 MHz RX: 729 MHz to 746 MHz
Bandwidth	WCDMA Band 2	5MHz
	WCDMA Band 5	5 MHz
	LTE Band 2	1.4MHz, 3MHz, 5MHz, 10MHz, 15MHz, 20MHz
	LTE Band 4	1.4MHz, 3MHz, 5MHz, 10MHz, 15MHz, 20MHz
	LTE Band 12	1.4MHz, 3MHz, 5MHz, 10MHz
Hardware Version	N/A	
Software Version	N/A	
Antenna Type	Chip Antenna (BT), LTE/GSM Passive Antenna (LTE/WCDMA)	
Antenna Gain	-6.5 dBi (Chip Antenna), 0dBi (LTE/GSM Passive Antenna)	
Antenna Connector	Mounted on PC board (BT) and Reverse SMA (LTE/WCDMA)	
Accessory Device	N/A	

Note:

- The EUT consumes power from the DC power supply

MODEL	RIGOL DP712
RATING	13.8Vdc

- The above EUT information is declared by manufacturer and for more detailed features description, please refer to the manufacturer's specifications or User's Manual.

### 3.1.1 Test Mode Applicability

EUT CONFIGURE MODE	APPLICABLE TO				DESCRIPTION
	RE $\geq$ 1G	RE<1G	PLC	APCM	
-	√	√	-	-	

Where **RE $\geq$ 1G**: Radiated Emission above 1GHz      **RE<1G**: Radiated Emission below 1GHz  
**PLC**: Power Line Conducted Emission      **APCM**: Antenna Port Conducted Measurement

**NOTE:**

1. The EUT had been pre-tested on the positioned of each 3 axis. The worst case was found when positioned on **X-plane**.
3. "-" means no effect.

### 3.2 Description of Support Units

The EUT has been tested as an independent unit together with other necessary accessories or support units. The following support units or accessories were used to form a representative test configuration during the tests.

ID	Product	Brand	Model No.	Serial No.	FCC ID	Remarks
A.	DC Power Supply	RIGOL	DP712	DP7B182100095	N/A	-
B.	Wideband Radio Communicator	Rohde & Schwarz	CMW500	108852	NA	-

Note:

1. All power cords of the above support units are non-shielded (1.8m).

ID	Descriptions	Qty.	Length (m)	Shielding (Yes/No)	Cores (Qty.)	Remarks
1.	USB Cable	1	1	No	-	Connect USB cable between USB port on the Jig and USB port on PC.
2.	DC Cable	1	`	No	-	Supply DC13.8V to IP501M.
3.						

Note: The core(s) is(are) originally attached to the cable(s).

### 3.2.1 Configuration of System under Test

<Radiated Emission Test>

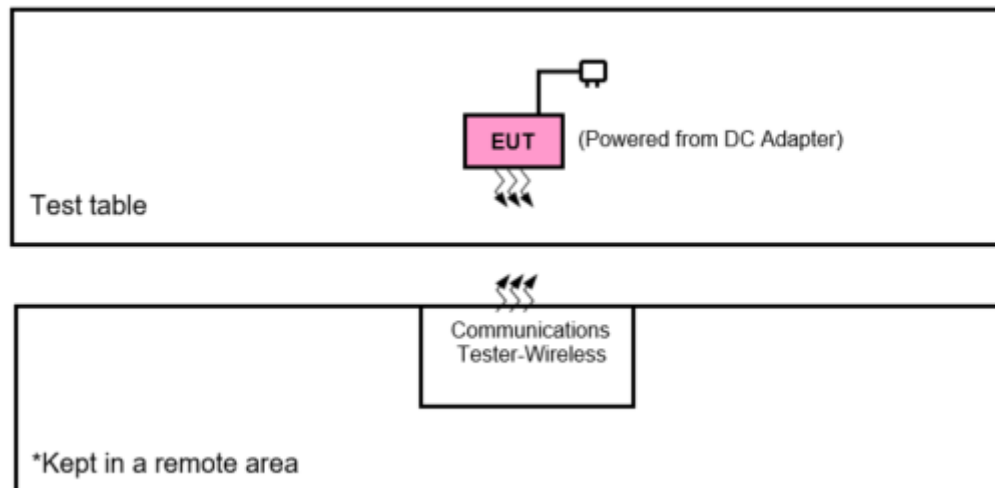



### **3.3 General Description of Applied Standards**

The EUT is a RF Product. According to the specifications of the manufacturer, it must comply with the requirements of the following standards:

**47 CFR FCC 15.247**  
**RSS247 Issue 2, February 2017**

All test items have been performed and recorded as per the above standards.

## 4 Test Types and Results

### 4.1 Radiated Emission and Bandedge Measurement

#### 4.1.1 Limits of Radiated Emission and Bandedge Measurement

Radiated emissions which fall in the restricted bands must comply with the radiated emission limits specified as below table. Other emissions shall be at least 20dB below the highest level of the desired power:

Frequencies (MHz)	Field Strength (microvolts/meter)	Measurement Distance (meters)
0.009 ~ 0.490	2400/F(kHz)	300
0.490 ~ 1.705	24000/F(kHz)	30
1.705 ~ 30.0	30	30
30 ~ 88	100	3
88 ~ 216	150	3
216 ~ 960	200	3
Above 960	500	3

#### NOTE:

1. The lower limit shall apply at the transition frequencies.
2. Emission level (dBuV/m) = 20 log Emission level (uV/m).
3. For frequencies above 1000MHz, the field strength limits are based on average detector, however, the peak field strength of any emission shall not exceed the maximum permitted average limits, specified above by more than 20dB under any condition of modulation.

#### 4.1.2 Test Instruments

Refer to section 2.3 to get information of above instrument.

#### 4.1.3 Test Procedures

##### For Radiated emission above 30MHz

- a. The EUT was placed on the top of a rotating table 0.8 meters (for 30MHz ~ 1GHz) / 1.5 meters (for above 1GHz) above the ground at 3 meter chamber room for test. The table was rotated 360 degrees to determine the position of the highest radiation.
- b. The EUT was set 3 meters away from the interference-receiving antenna, which was mounted on the top of a variable-height antenna tower.
- c. The height of antenna is varied from one meter to four meters above the ground to determine the maximum value of the field strength. Both horizontal and vertical polarizations of the antenna are set to make the measurement.
- d. For each suspected emission, the EUT was arranged to its worst case and then the antenna was tuned to heights from 1 meter to 4 meters and the rotatable table was turned from 0 degrees to 360 degrees to find the maximum reading.
- e. The test-receiver system was set to quasi-peak detect function and specified bandwidth with maximum hold mode when the test frequency is below 1 GHz.
- f. The test-receiver system was set to peak and average detect function and specified bandwidth with maximum hold mode when the test frequency is above 1 GHz. If the peak reading value also meets

average limit, measurement with the average detector is unnecessary.

**Note:**

1. The resolution bandwidth and video bandwidth of test receiver/spectrum analyzer is 120kHz for Quasi-peak detection (QP) at frequency below 1GHz.
  2. The resolution bandwidth of test receiver/spectrum analyzer is 1 MHz and the video bandwidth is 3 MHz for Peak detection (PK) at frequency above 1GHz.
  3. The resolution bandwidth of test receiver/spectrum analyzer is 1MHz and the video bandwidth is  $\geq 1/T$  (Duty cycle  $< 98\%$ ) or 10Hz (Duty cycle  $\geq 98\%$ ) for Average detection (AV) at frequency above 1GHz.
1. All modes of operation were investigated and the worst-case emissions are reported.

**4.1.4 Deviation from Test Standard**

No deviation.

#### 4.1.5 Test Setup

##### For Radiated emission 30MHz to 1GHz

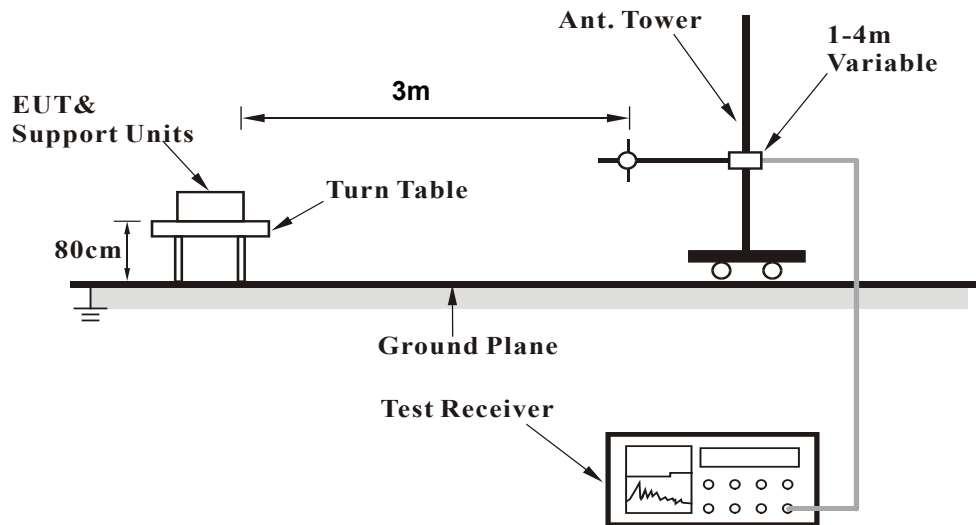

##### For Radiated emission above 1GHz

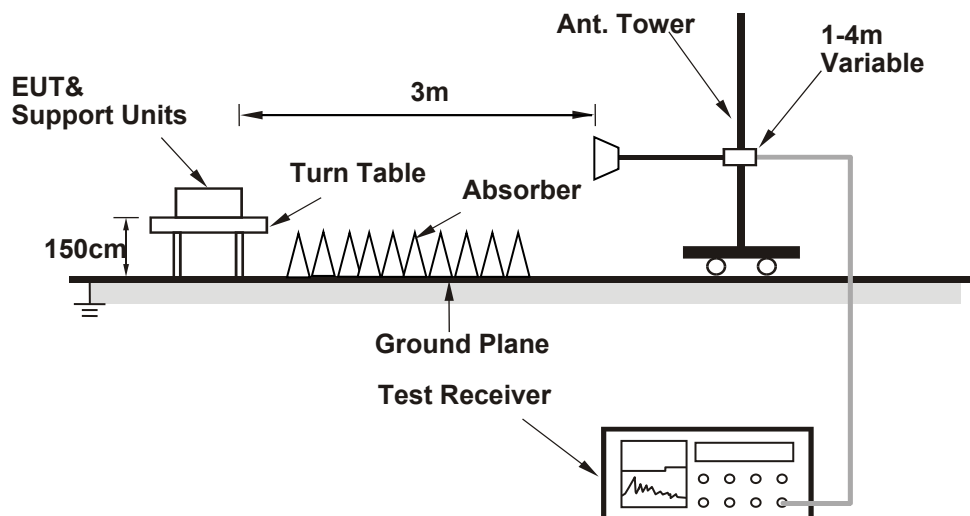

For the actual test configuration, please refer to the attached file (Test Setup Photo).

#### 4.1.6 EUT Operating Conditions

- Supply DC13.8V to IP501M.
- Connect USB cable between USB port on the Jig and USB port on PC.
- The other ports of the JIG are not connected.
- Controlling software (Teraterm and Bluetest 3) has been activated to set the EUT on specific status.

#### 4.1.7 Test Results

Below 1GHz Data:

BT Band LTE transmitting:



Frequency (MHz)	Raw (dBuV)	Cable Loss (dB)	AF (dB)	Level (dBuV/m)	Measurement Type	Pol (V/H)	Hgt (cm)	Azt (Deg)	Limit (dBuV/m)	Margin (dB)	Pass /Fail
143.52	35.15	12.20	-23.62	23.74	Quasi Max	H	224	282	43.5	-19.76	Pass
345.02	44.88	13.52	-21.28	37.12	Quasi Max	H	102	326	46	-8.88	Pass
549.97	28.78	14.45	-18.13	25.10	Quasi Max	H	177	44	46	-20.90	Pass
119.81	28.51	12.06	-22.74	17.84	Quasi Max	H	123	106	43.5	-25.66	Pass
798.21	20.04	15.47	-14.06	21.45	Quasi Max	H	398	151	46	-24.55	Pass
53.95	29.63	11.47	-26.74	14.37	Quasi Max	H	177	306	40	-25.64	Pass

**Above 1GHz Data:**

**BT and LTE transmitting:**

Frequency (MHz)	Raw (dBuV)	Cable Loss (dB)	AF (dB)	Level (dBuV/m)	Measurement Type	Pol (V/H)	Hgt (cm)	Azt (Deg)	Limit (dBuV/m)	Margin (dB)	Pass /Fail
11855.47	46.17	8.15	-2.82	51.51	Peak Max	V	105	183	74	-22.49	Pass
1434.77	60.76	2.74	-16.87	46.63	Peak Max	V	127	97	74	-27.37	Pass
4838.82	51.17	5.66	-11.02	45.81	Peak Max	V	120	80	74	-28.19	Pass
11855.47	33.84	8.15	-2.82	39.17	Average Max	V	105	183	54	-14.83	Pass
1434.77	42.34	2.74	-16.87	28.21	Average Max	V	127	97	54	-25.79	Pass
4838.82	39.05	5.66	-11.02	33.69	Average Max	V	120	80	54	-20.31	Pass

**Note:** Possible co-location combinations are Bluetooth with LTE and Bluetooth with WCDMA module. The worst case combination of Bluetooth co-locating with LTE was tested in this report.

## Appendix – Information of the Testing Laboratories

Bureau Veritas is a global leader in testing, inspection and certification (TIC) services. We help businesses improve safety, sustainability and productivity; and our clients include the majority of leading brands in retail, manufacturing and other industries. With a presence in every major country around the world, our quality assurance and compliance solutions are vital in helping our customers enhance product quality and concept-to-consumer journeys. We also assist with increasing speed to market, profitability and brand equity throughout the supply chain. Bureau Veritas is a leading wireless/IoT testing, inspection, audit and certification provider, with a global network of test laboratories to support the IoT industry in areas of connectivity, security, interoperability as well as quality, health & safety, and environmental/chemical requirements.

If you have any comments, please feel free to contact us at the following:

**Milpitas EMC/RF/Safety/Telecom Lab**

775 Montague Expressway, Milpitas, CA 95035  
Tel: +1 408 526 1188

**Sunnyvale OTA/Bluetooth Lab**

1293 Anvilwood Avenue, Sunnyvale, CA  
94089  
Tel: +1 669 600 5293

**Littleton EMC/RF/Safety/Environmental Lab**

1 Distribution Center Cir #1, Littleton, MA 01460  
Tel: +1 978 486 8880

**Irvine OTA/PTCRB/Bluetooth/V2X Lab**

15 Musick, Irvine, CA 92618  
Tel: +1 949 716 6512

**Email:** [sales.eaw@us.bureauveritas.com](mailto:sales.eaw@us.bureauveritas.com)

**Web Site:** [www.cpsusa-bureauveritas.com](http://www.cpsusa-bureauveritas.com)

The address and road map of all our labs can be found in our web site also.

--- END ---