

**LTE Band 5 (16-QAM, Band Width 1.4MHz, RB Size 1, RB Offset 5, Channel 20643, Frequency 848.3MHz)**

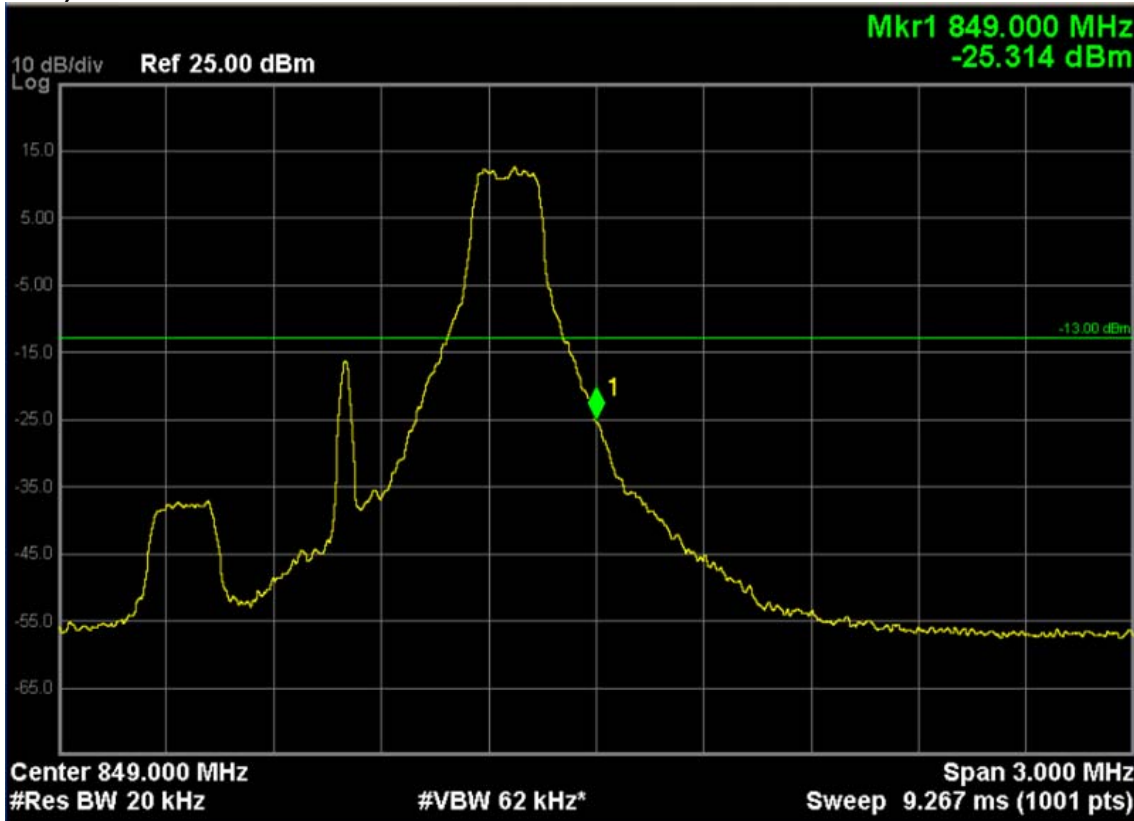

**LTE Band 5 (16-QAM, Band Width 1.4MHz, RB Size 6, RB Offset 0, Channel 20643, Frequency 848.3MHz)**

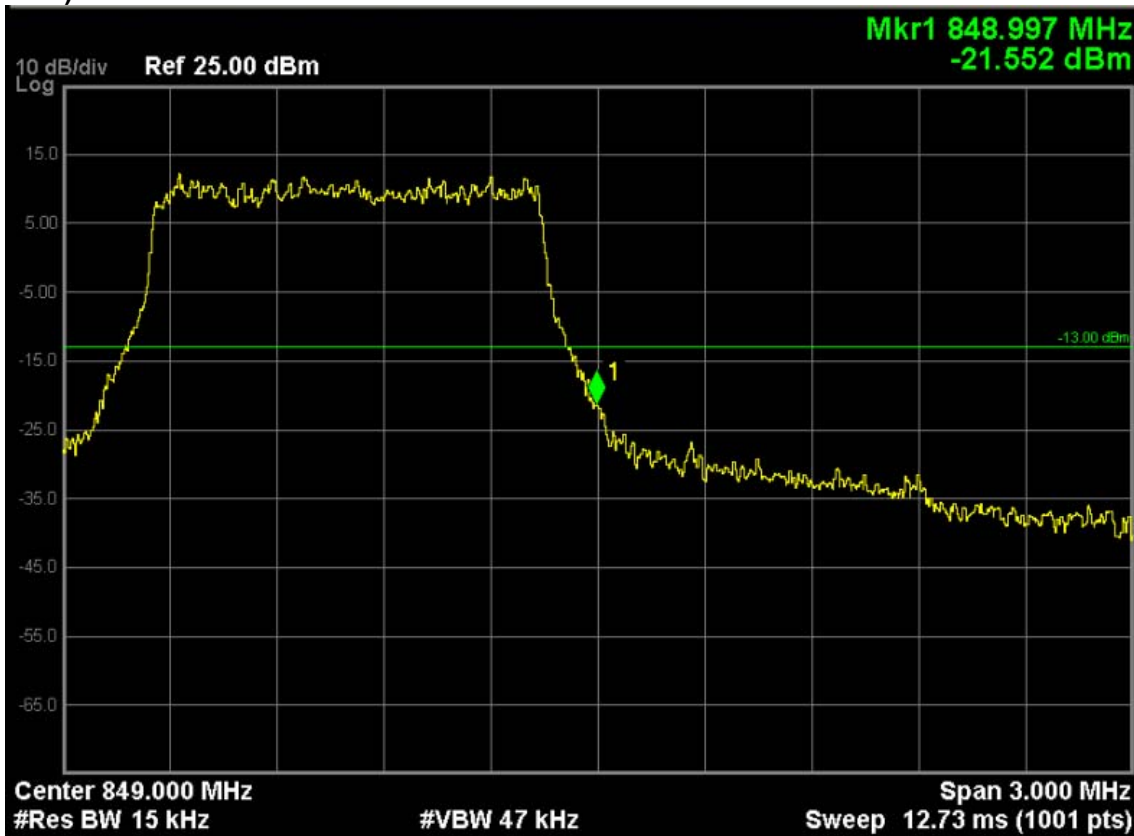

**LTE Band 5 (QPSK, Band Width 3MHz, RB Size 1, RB Offset 0, Channel 20415, Frequency 825.5MHz)**

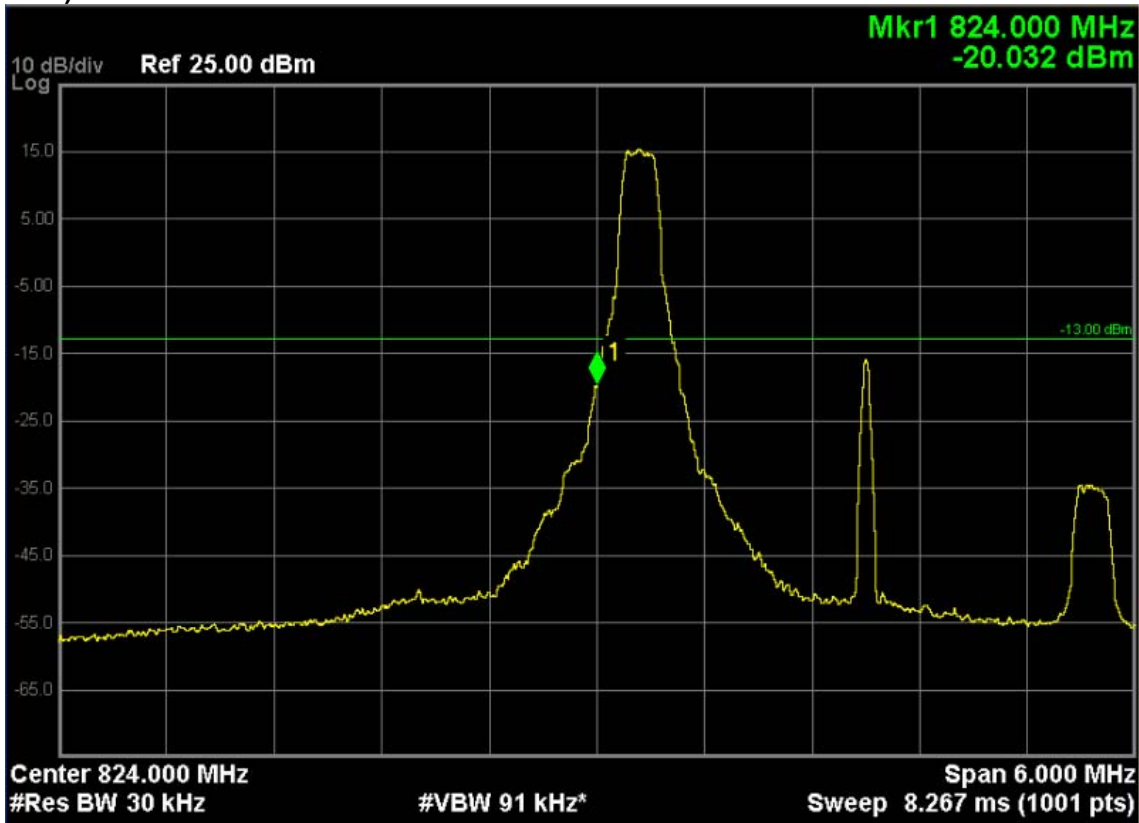

**LTE Band 5 (QPSK, Band Width 3MHz, RB Size 15, RB Offset 0, Channel 20415, Frequency 825.5MHz)**

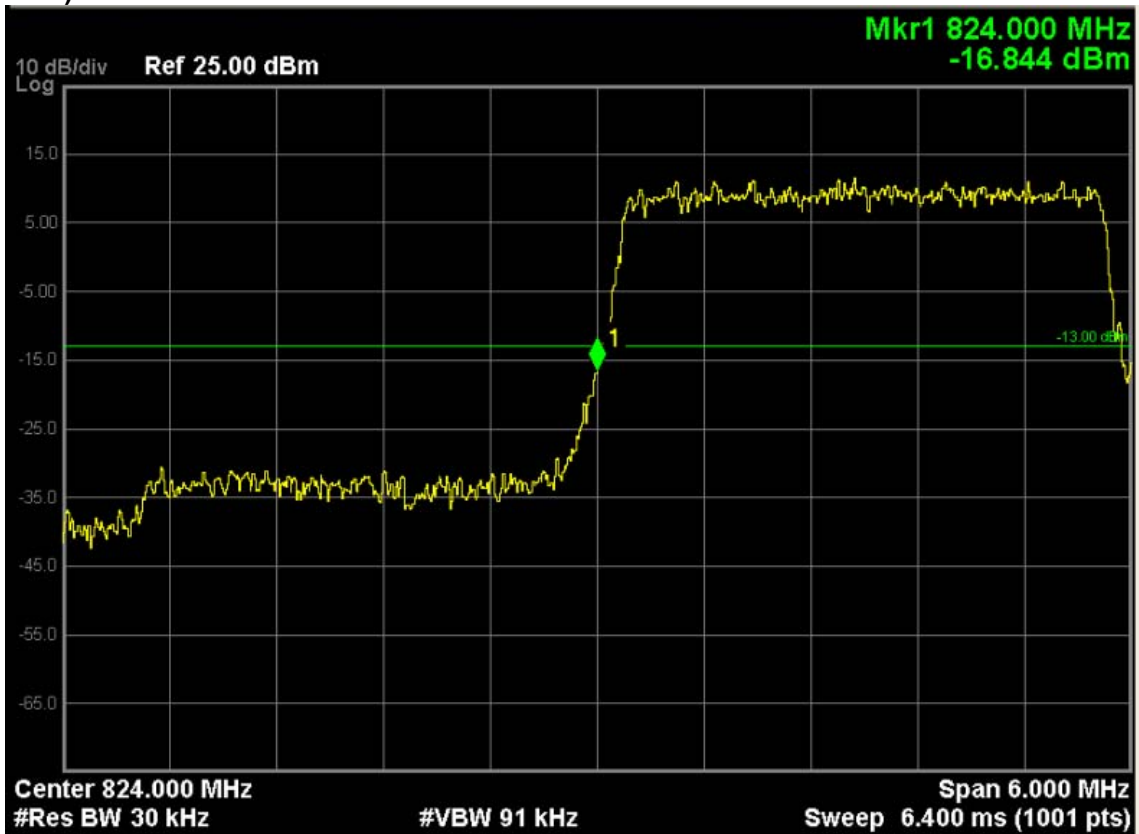

**LTE Band 5 (QPSK, Band Width 3MHz, RB Size 1, RB Offset 14, Channel 20635, Frequency 847.5MHz)**

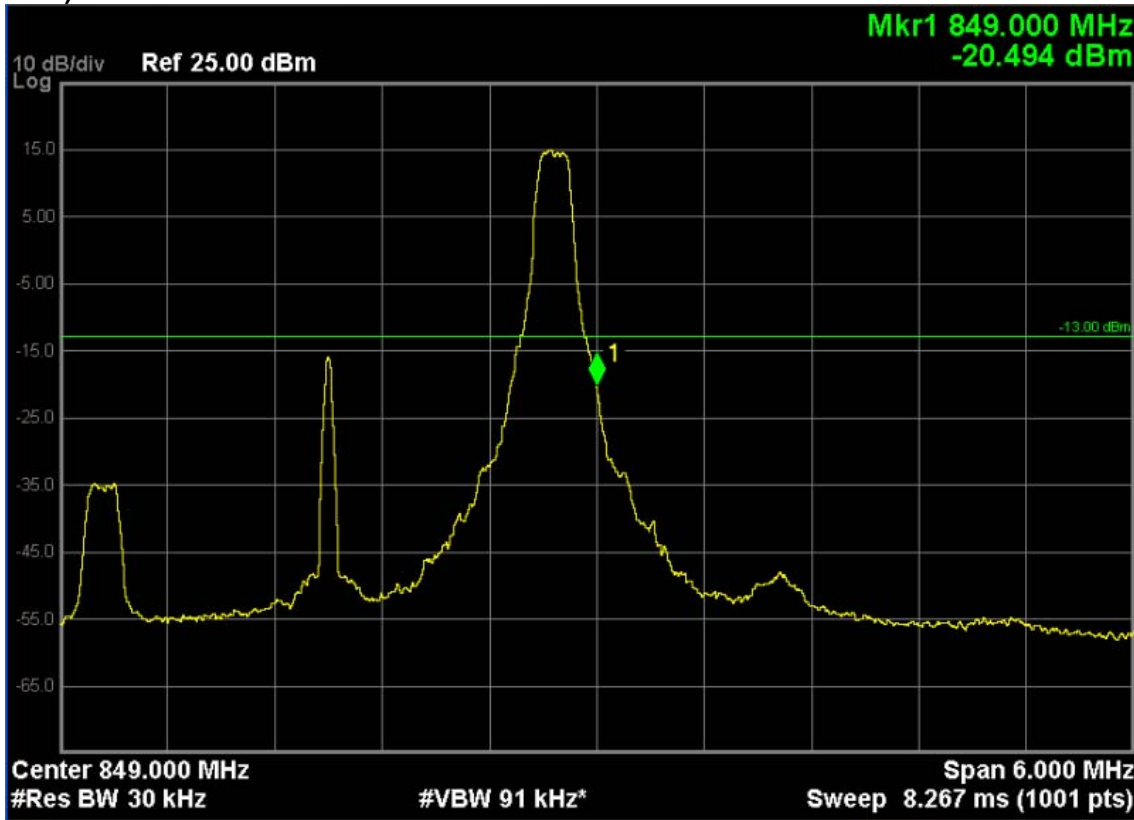

**LTE Band 5 (QPSK, Band Width 3MHz, RB Size 15, RB Offset 0, Channel 20635, Frequency 847.5MHz)**

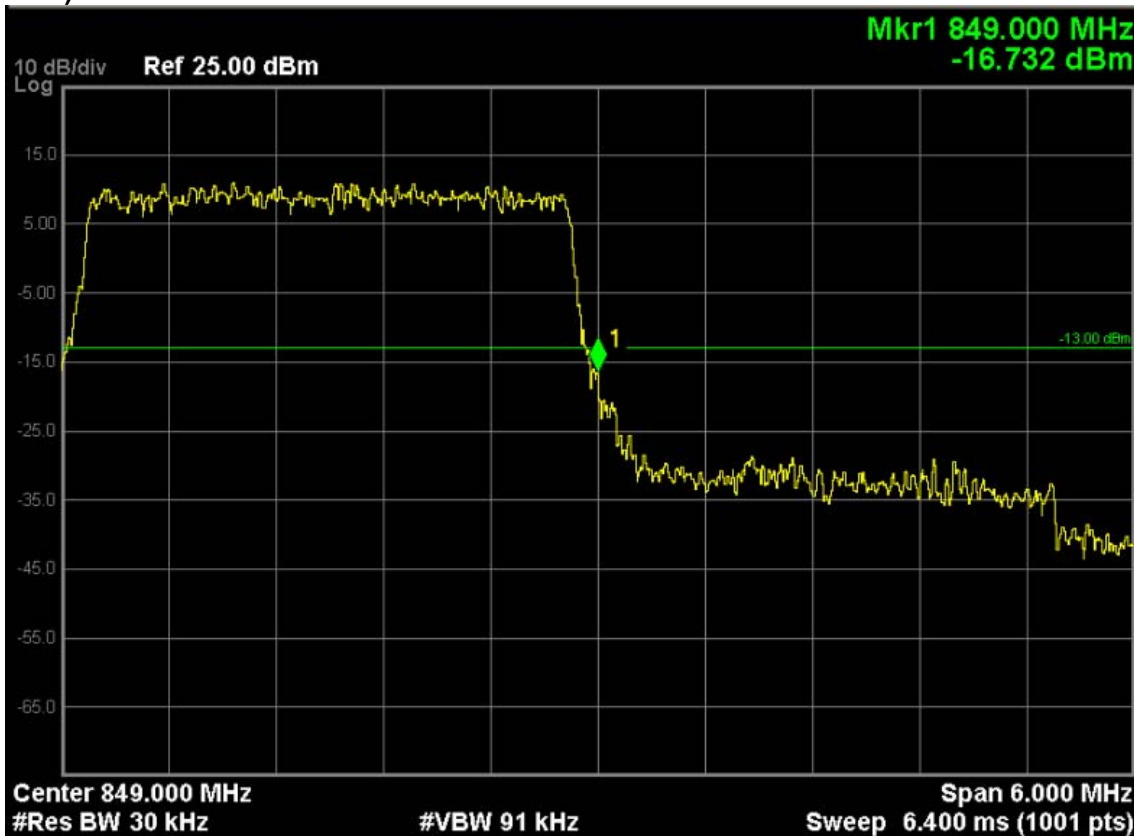

**LTE Band 5 (16-QAM, Band Width 3MHz, RB Size 1, RB Offset 0, Channel 20415, Frequency 825.5MHz)**

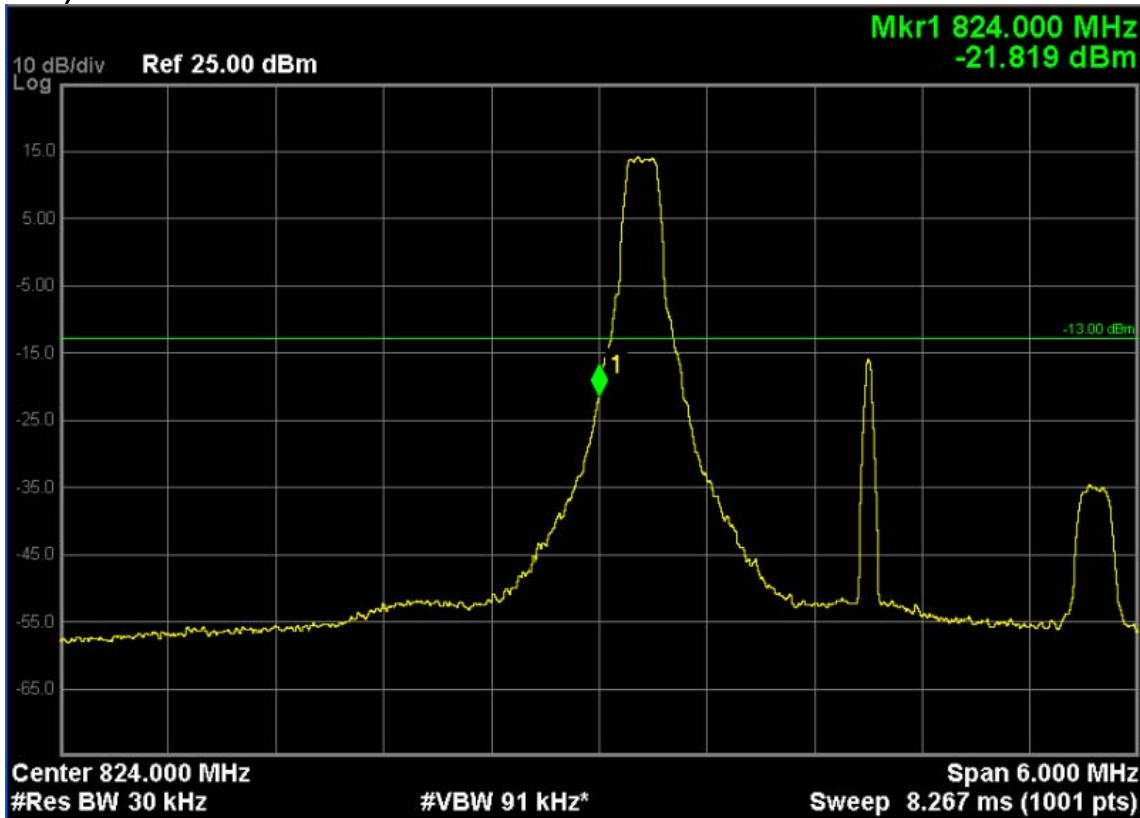

**LTE Band 5 (16-QAM, Band Width 3MHz, RB Size 15, RB Offset 0, Channel 20415, Frequency 825.5MHz)**

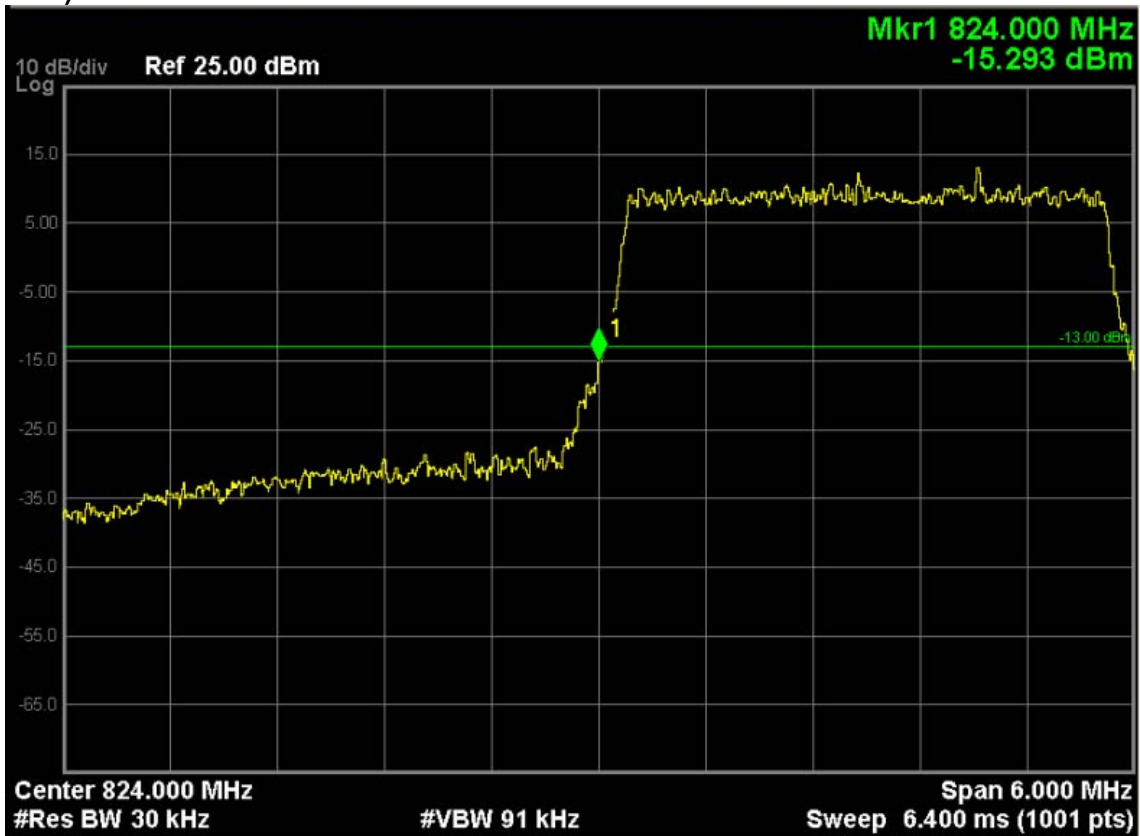

**LTE Band 5 (16-QAM, Band Width 3MHz, RB Size 1, RB Offset 14, Channel 20635, Frequency 847.5MHz)**

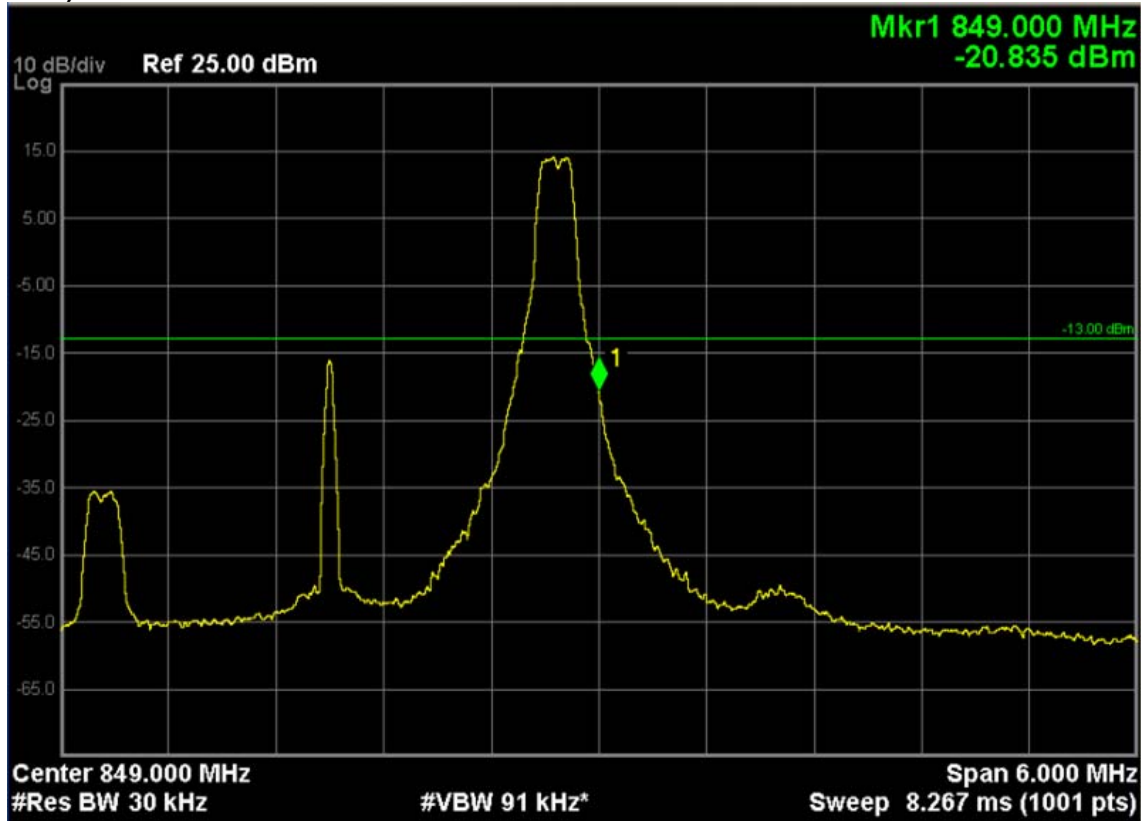

**LTE Band 5 (16-QAM, Band Width 3MHz, RB Size 15, RB Offset 0, Channel 20635, Frequency 847.5MHz)**

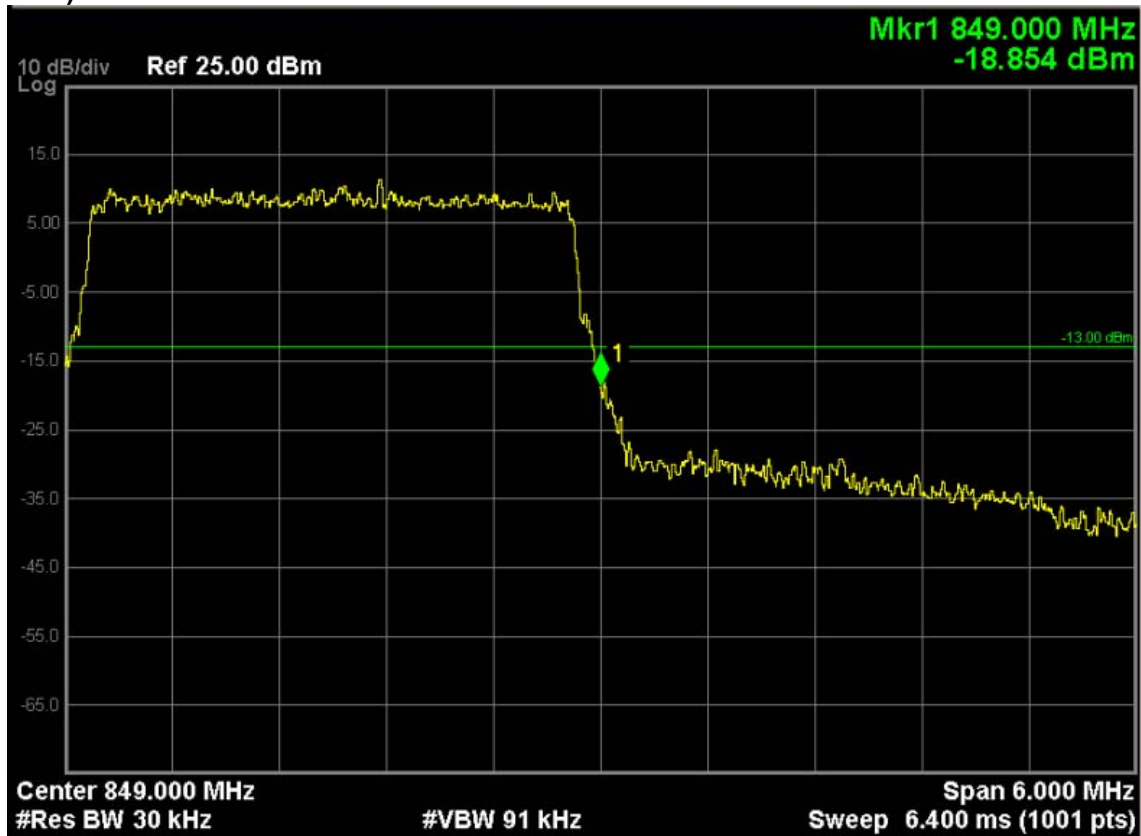

**LTE Band 5 (QPSK, Band Width 5MHz, RB Size 1, RB Offset 0, Channel 20425, Frequency 826.5MHz)**

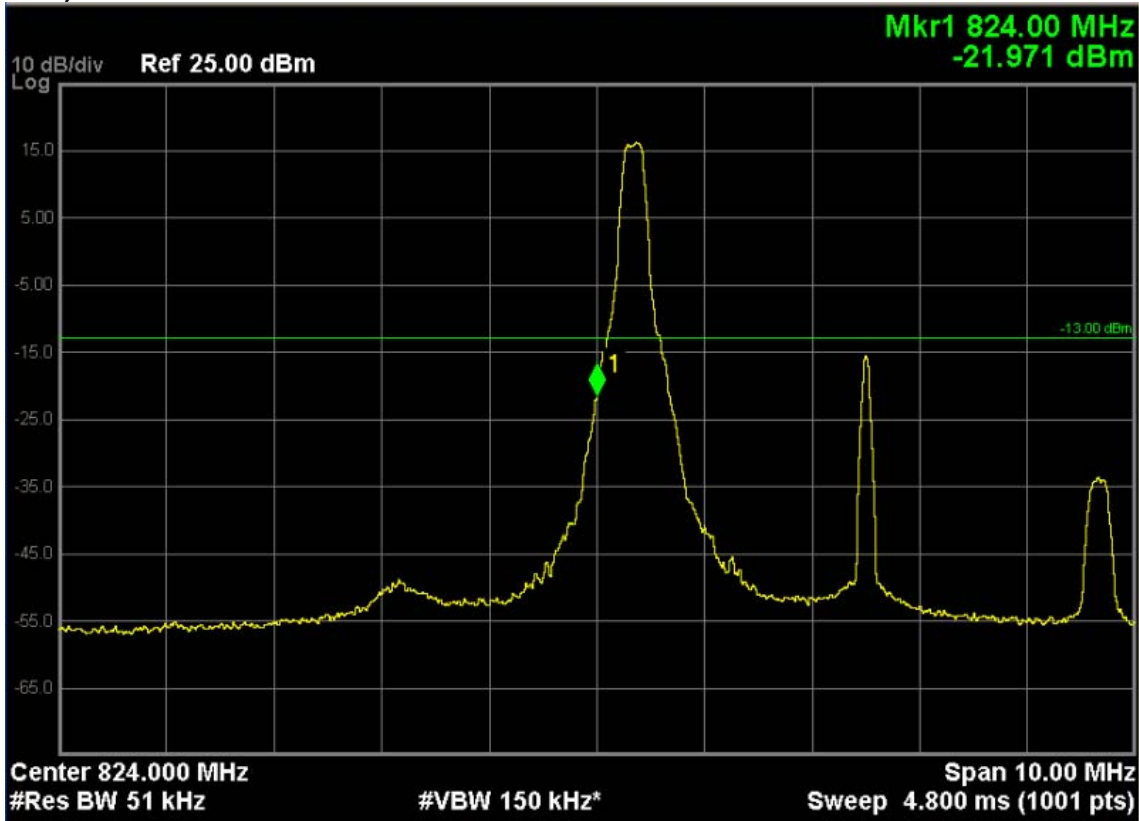

**LTE Band 5 (QPSK, Band Width 5MHz, RB Size 25, RB Offset 0, Channel 20425, Frequency 826.5MHz)**



**LTE Band 5 (QPSK, Band Width 5MHz, RB Size 1, RB Offset 24, Channel 20625, Frequency 846.5MHz)**

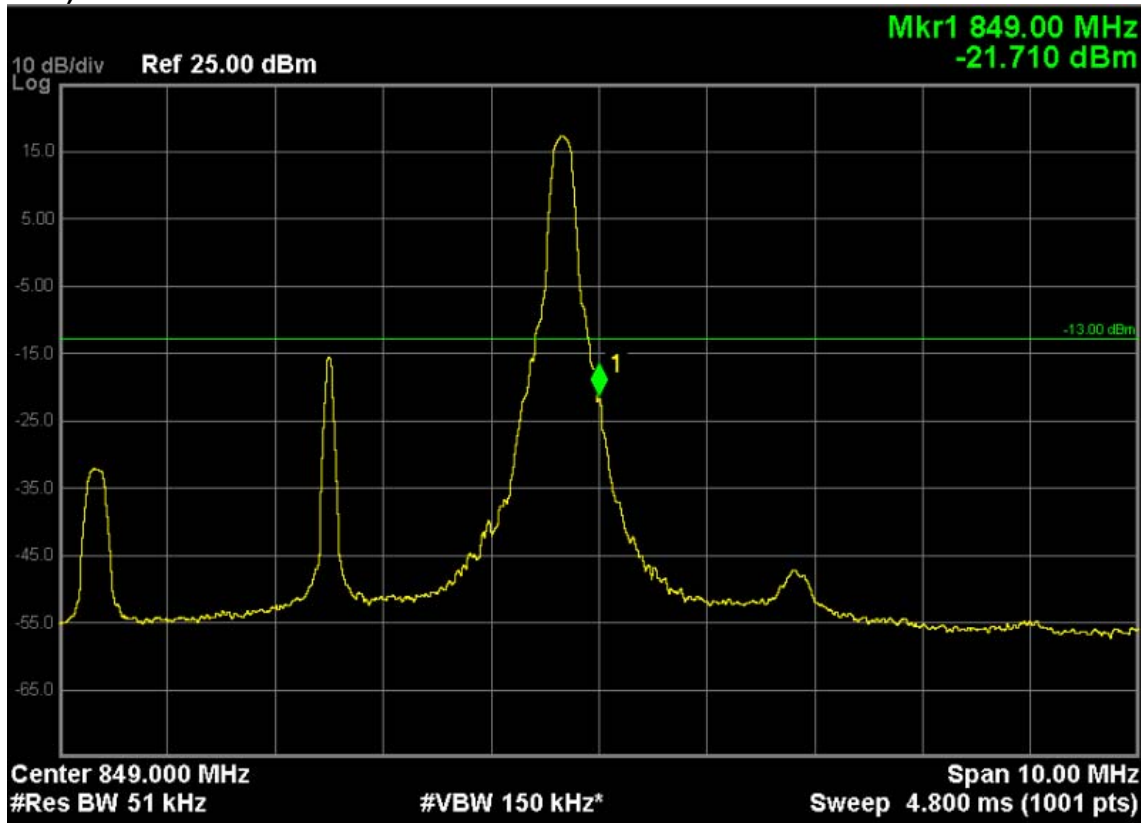

**LTE Band 5 (QPSK, Band Width 5MHz, RB Size 25, RB Offset 0, Channel 20625, Frequency 846.5MHz)**



**LTE Band 5 (16-QAM, Band Width 5MHz, RB Size 1, RB Offset 0, Channel 20425, Frequency 826.5MHz)**

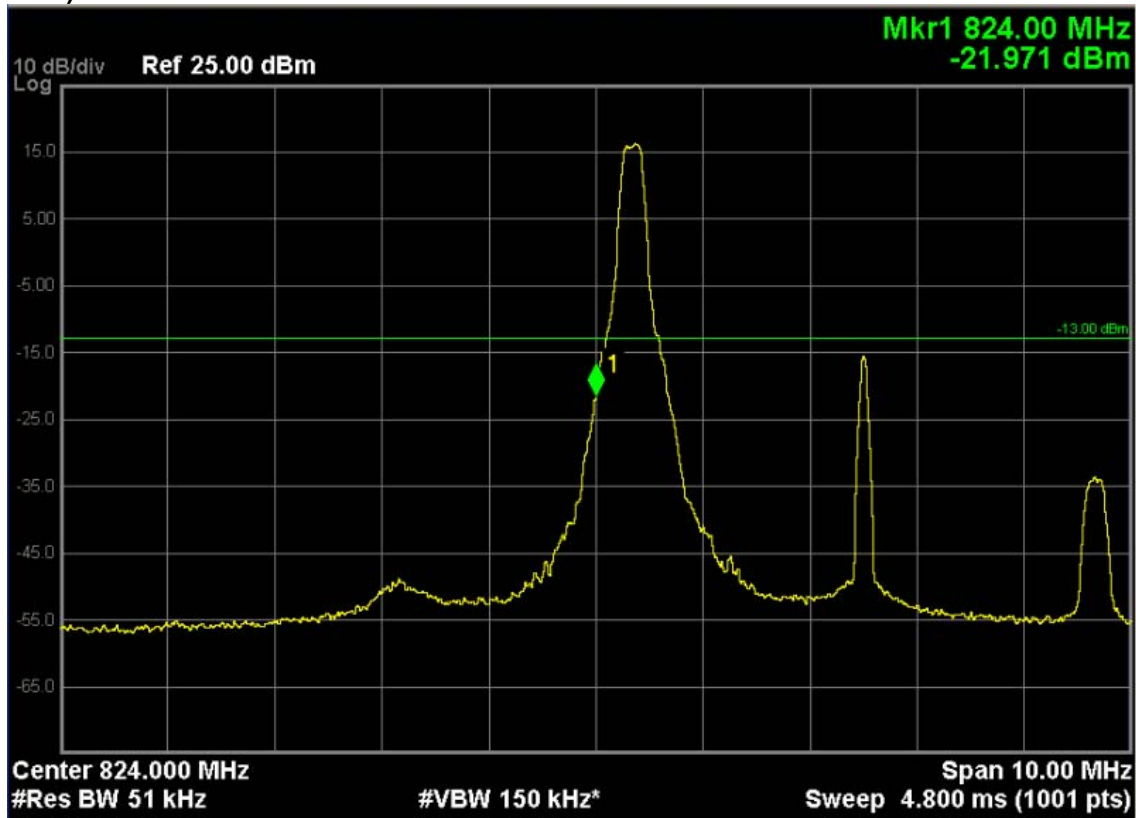

**LTE Band 5 (16-QAM, Band Width 5MHz, RB Size 25, RB Offset 0, Channel 20425, Frequency 826.5MHz)**

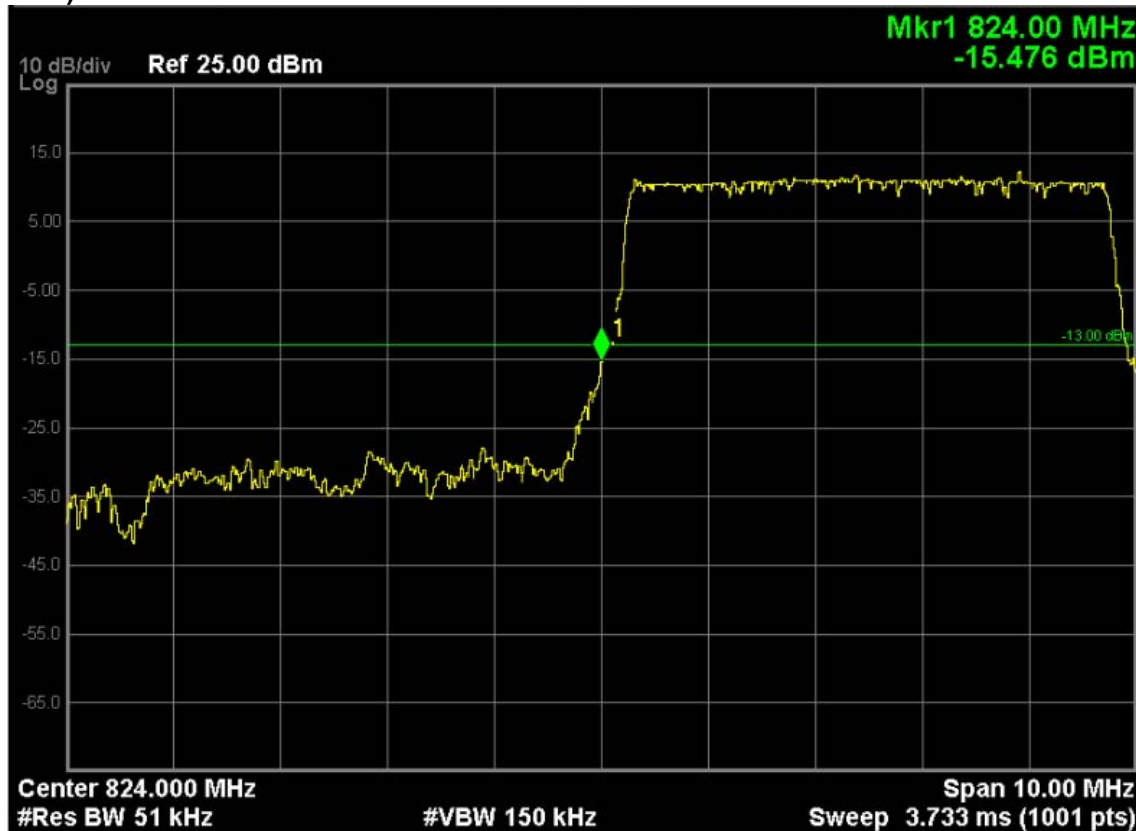



**LTE Band 5 (16-QAM, Band Width 5MHz, RB Size 1, RB Offset 24, Channel 20625, Frequency 846.5MHz)**

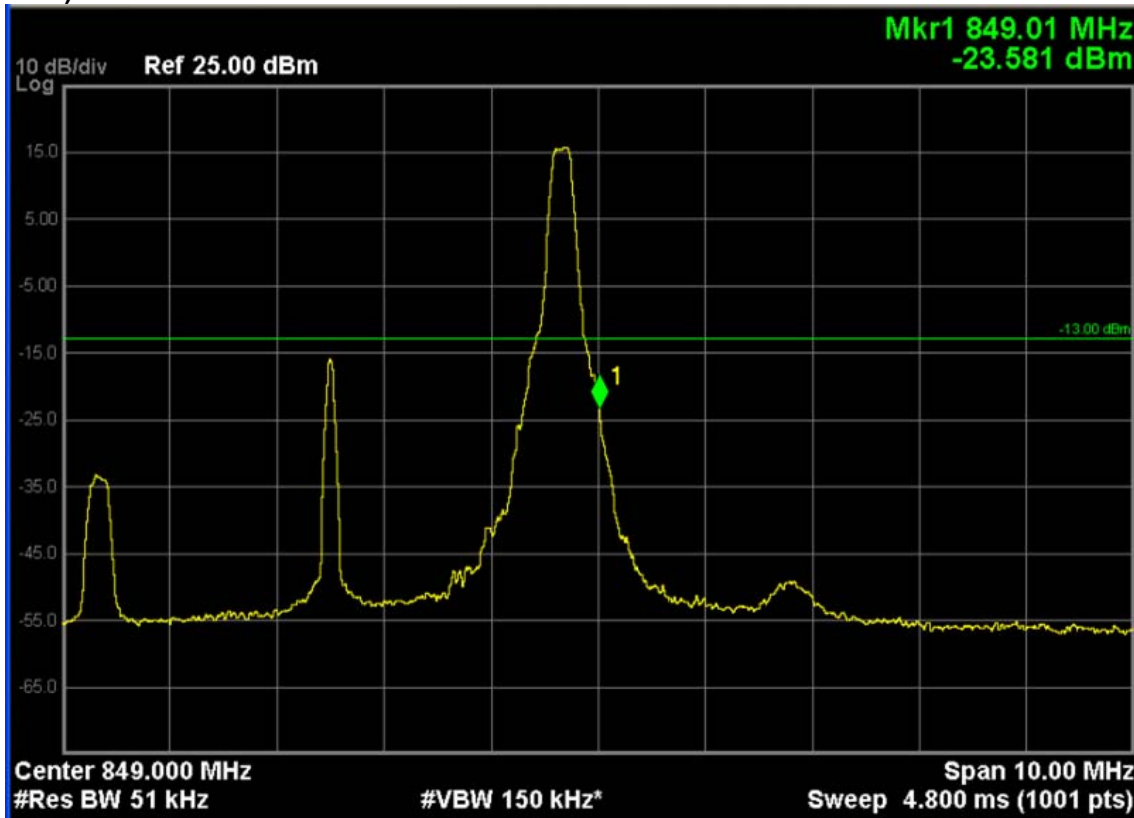

**LTE Band 5 (16-QAM, Band Width 5MHz, RB Size 25, RB Offset 0, Channel 20625, Frequency 846.5MHz)**

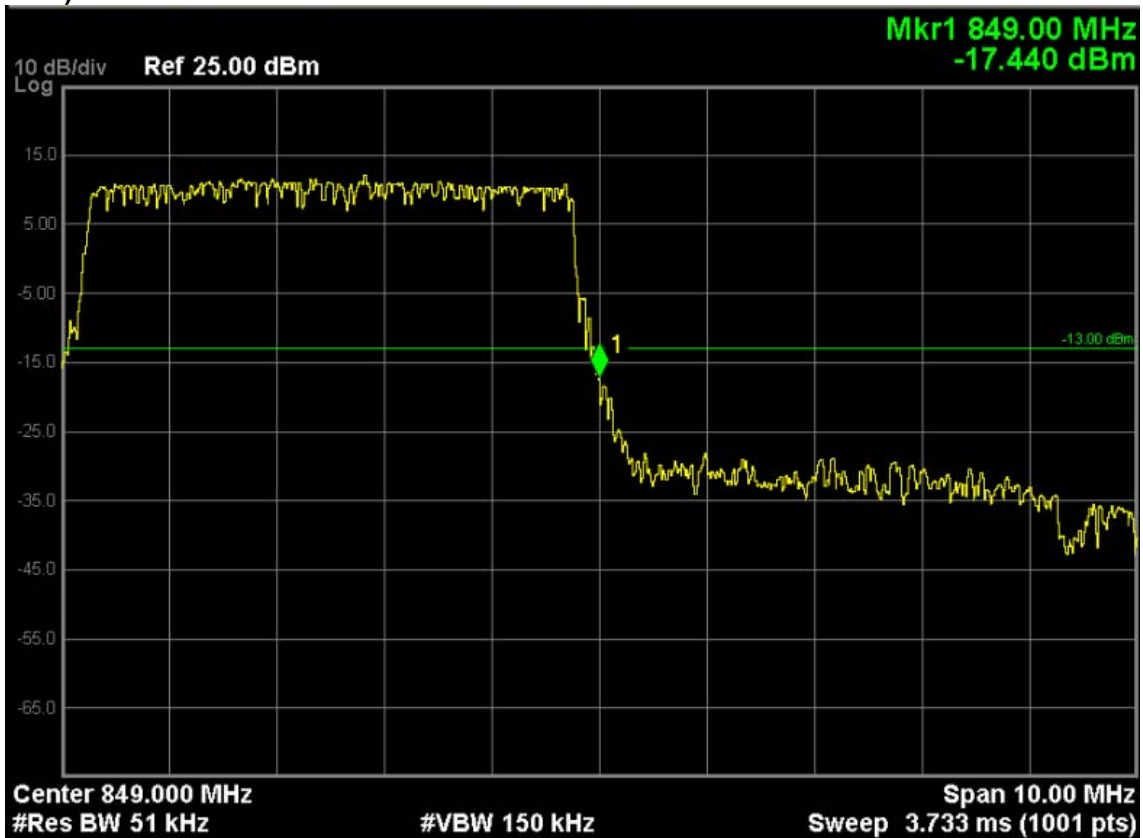

**LTE Band 5 (QPSK, Band Width 10MHz, RB Size 1, RB Offset 0, Channel 20450, Frequency 829.0MHz)**

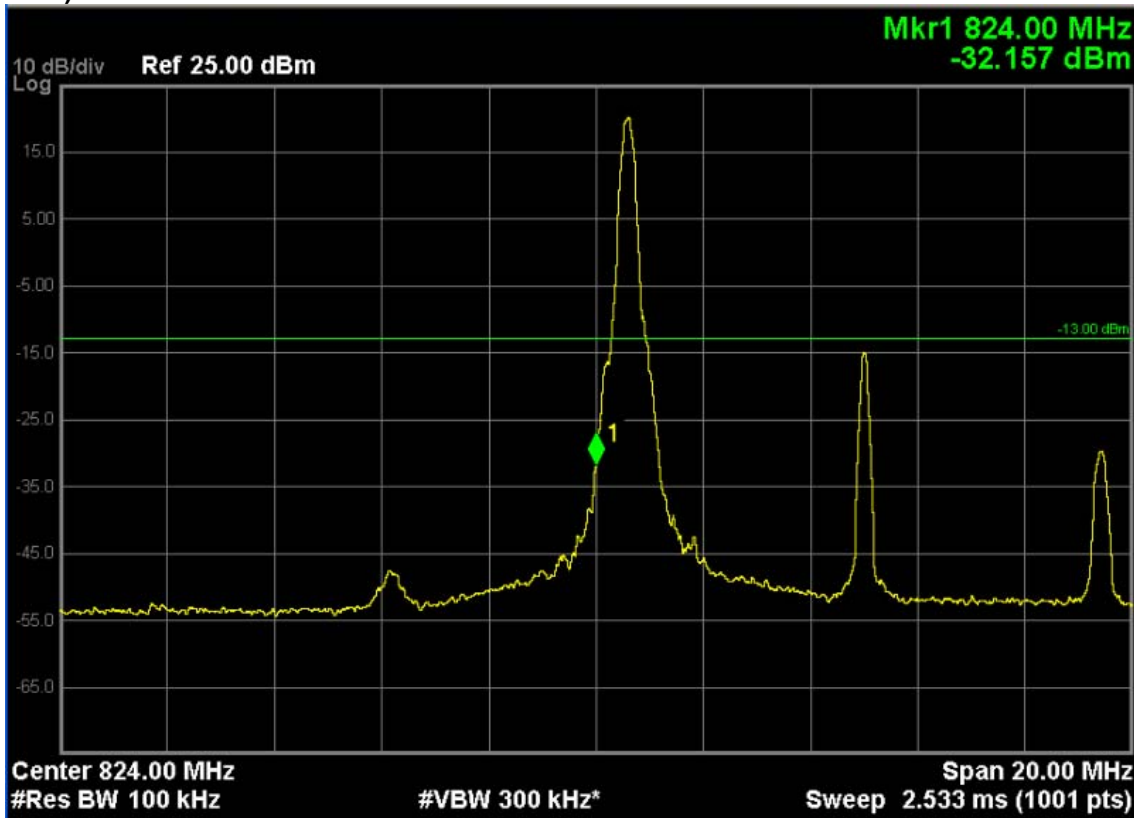

**LTE Band 5 (QPSK, Band Width 10MHz, RB Size 50, RB Offset 0, Channel 20450, Frequency 829.0MHz)**

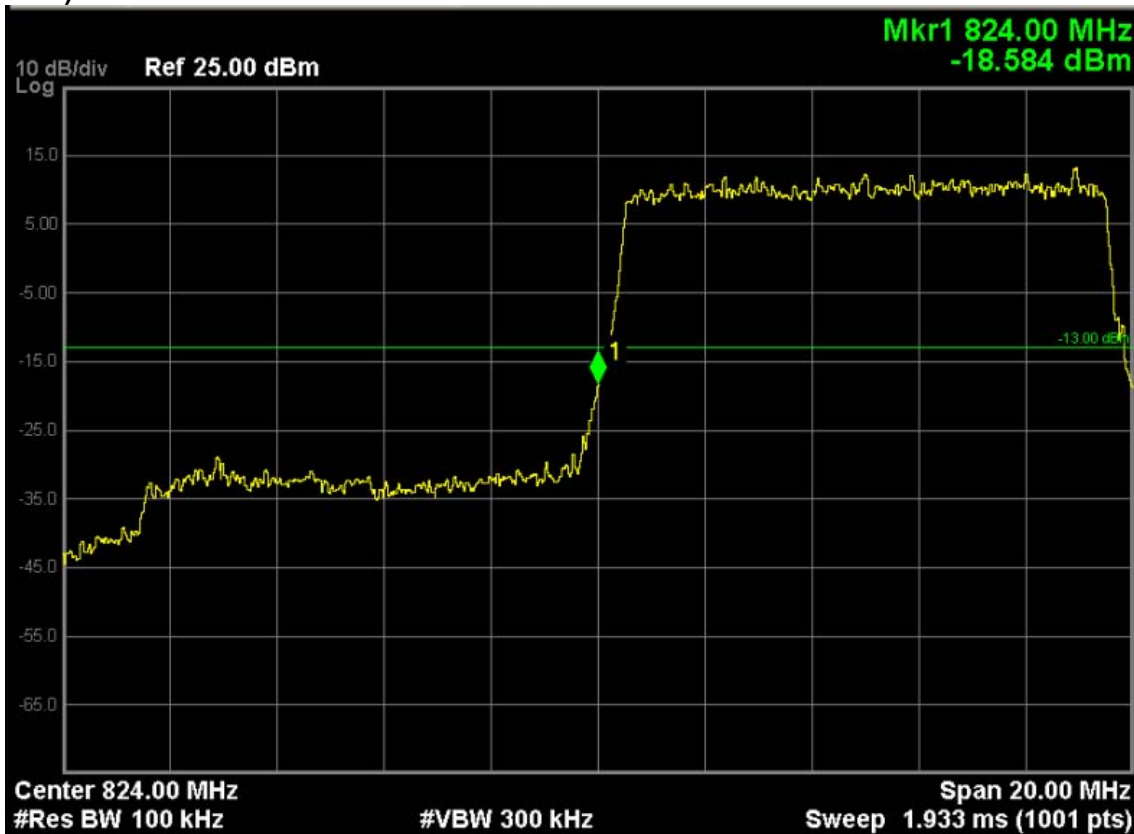

**LTE Band 5 (QPSK, Band Width 10MHz, RB Size 1, RB Offset 49, Channel 20600, Frequency 844.0MHz)**

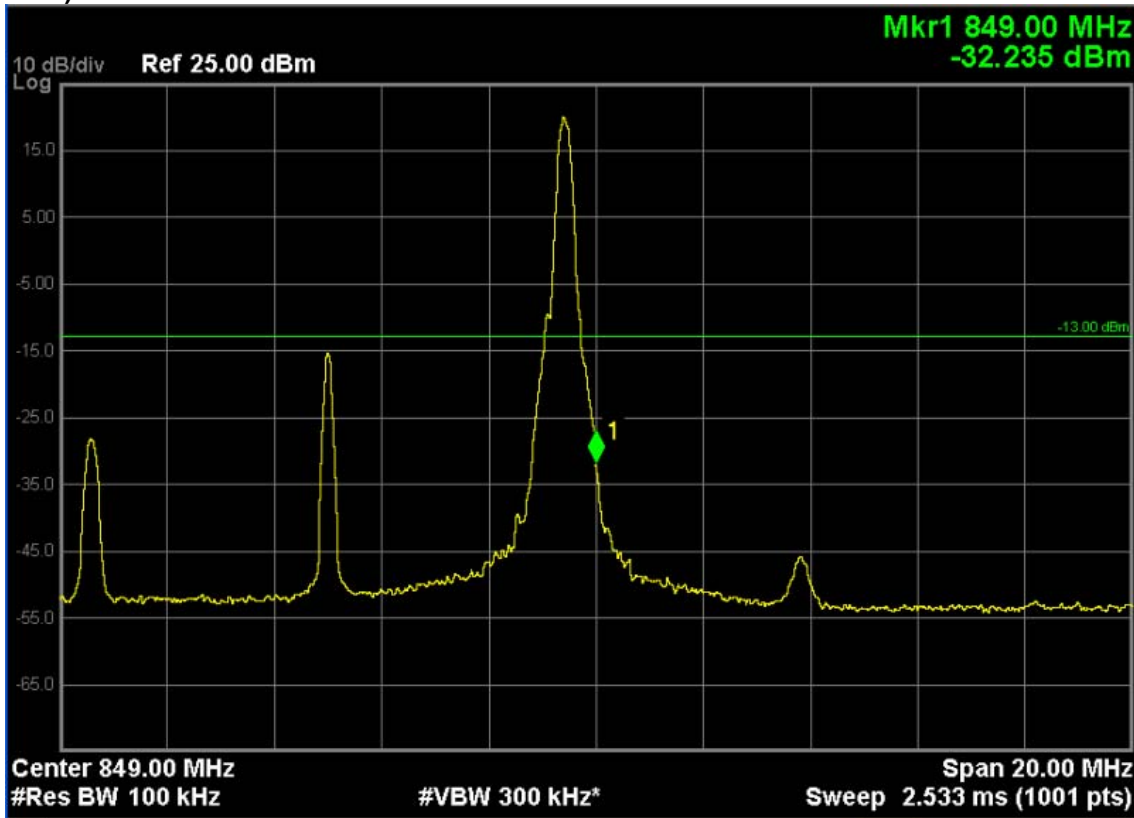

**LTE Band 5 (QPSK, Band Width 10MHz, RB Size 50, RB Offset 0, Channel 20600, Frequency 844.0MHz)**

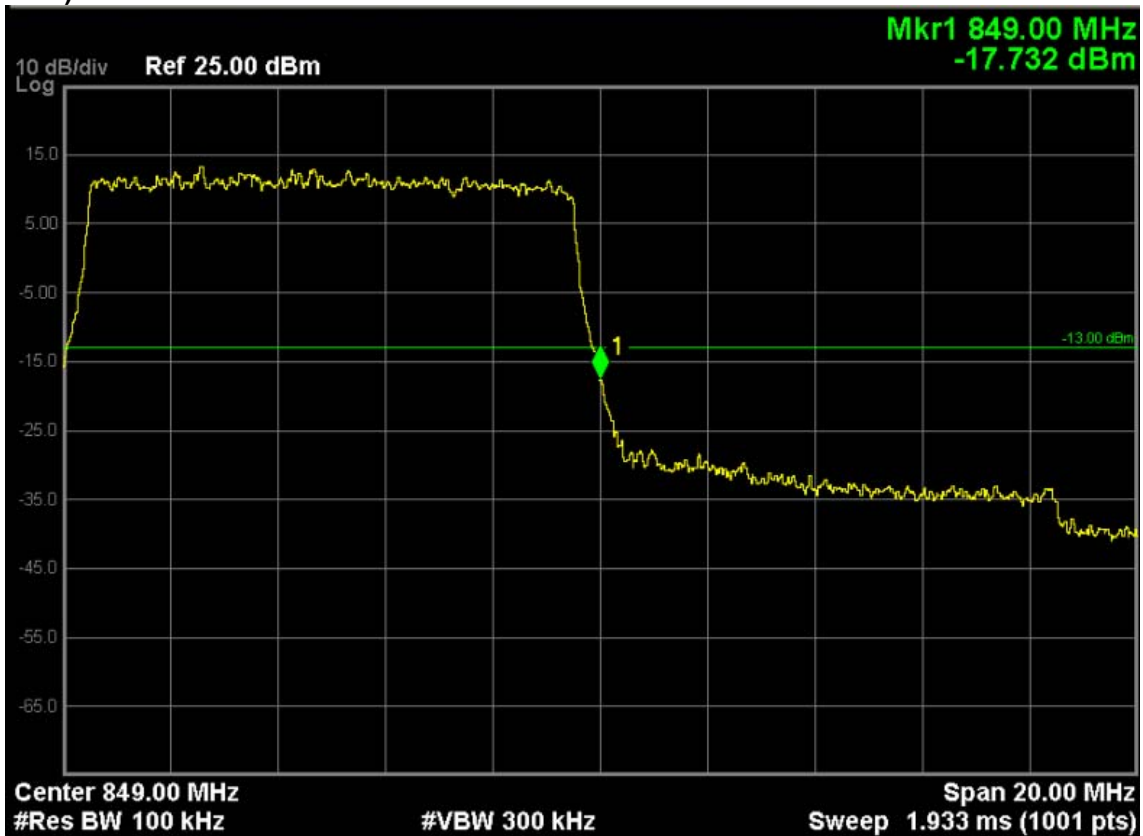

**LTE Band 5 (16-QAM, Band Width 10MHz, RB Size 1, RB Offset 0, Channel 20450, Frequency 829.0MHz)**

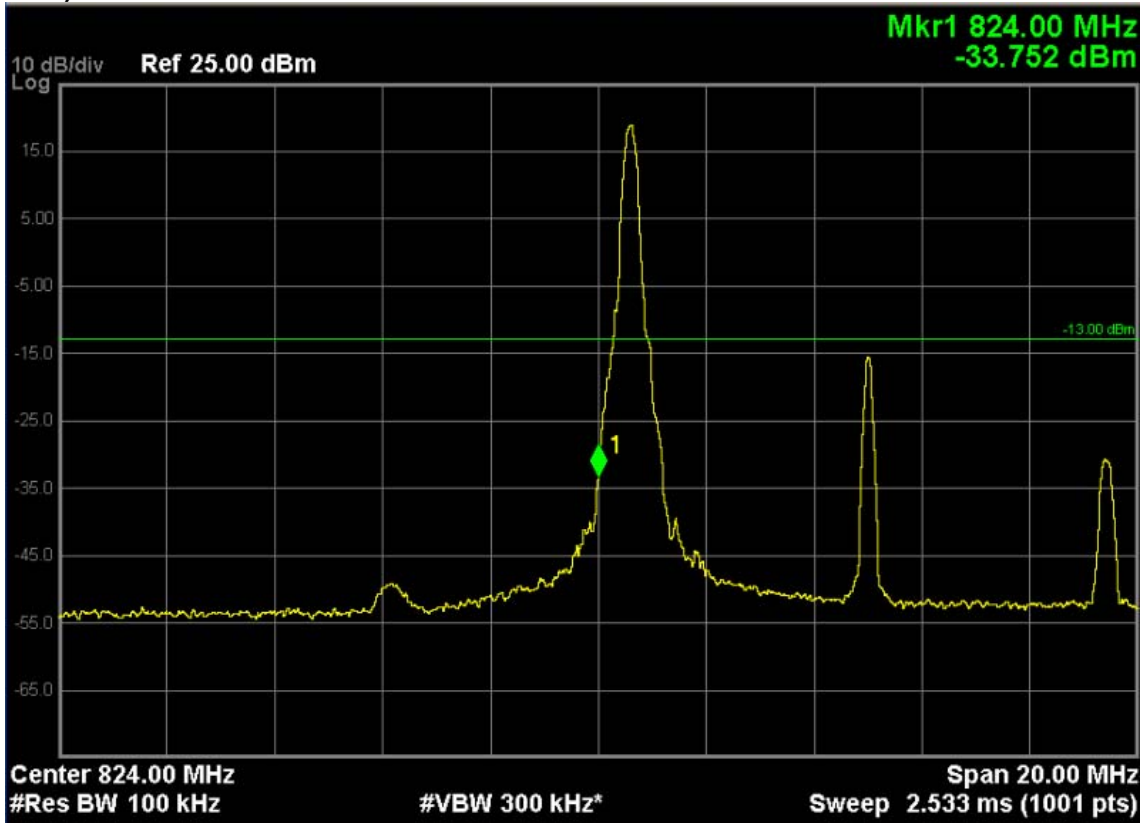

**LTE Band 5 (16-QAM, Band Width 10MHz, RB Size 50, RB Offset 0, Channel 20450, Frequency 829.0MHz)**

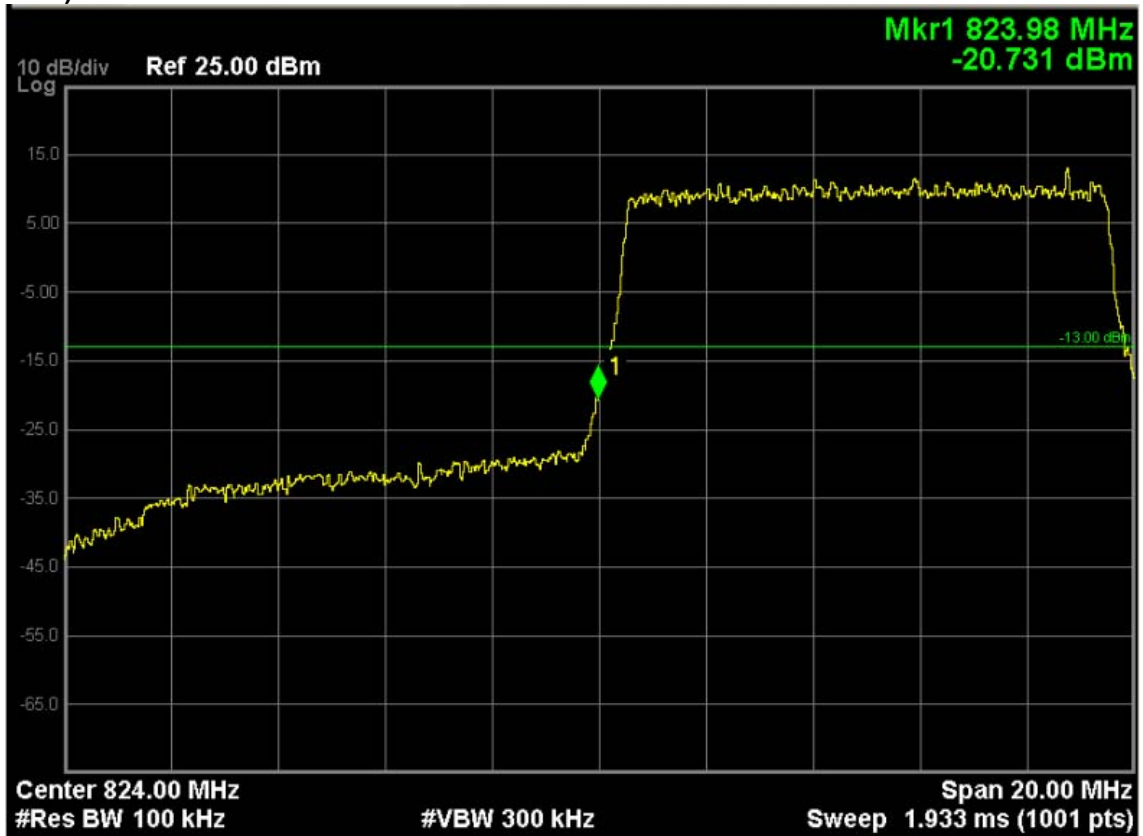

**LTE Band 5 (16-QAM, Band Width 10MHz, RB Size 1, RB Offset 49, Channel 20600, Frequency 844.0MHz)**

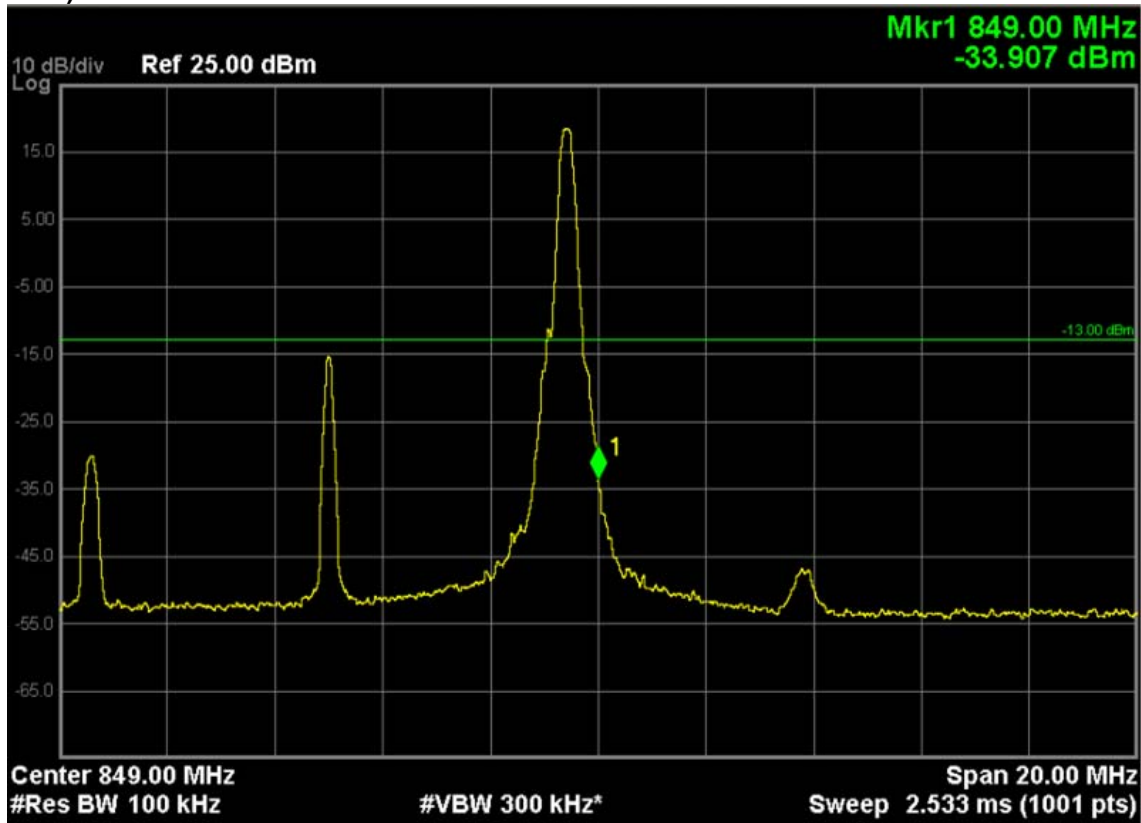

**LTE Band 5 (16-QAM, Band Width 10MHz, RB Size 50, RB Offset 0, Channel 20600, Frequency 844.0MHz)**

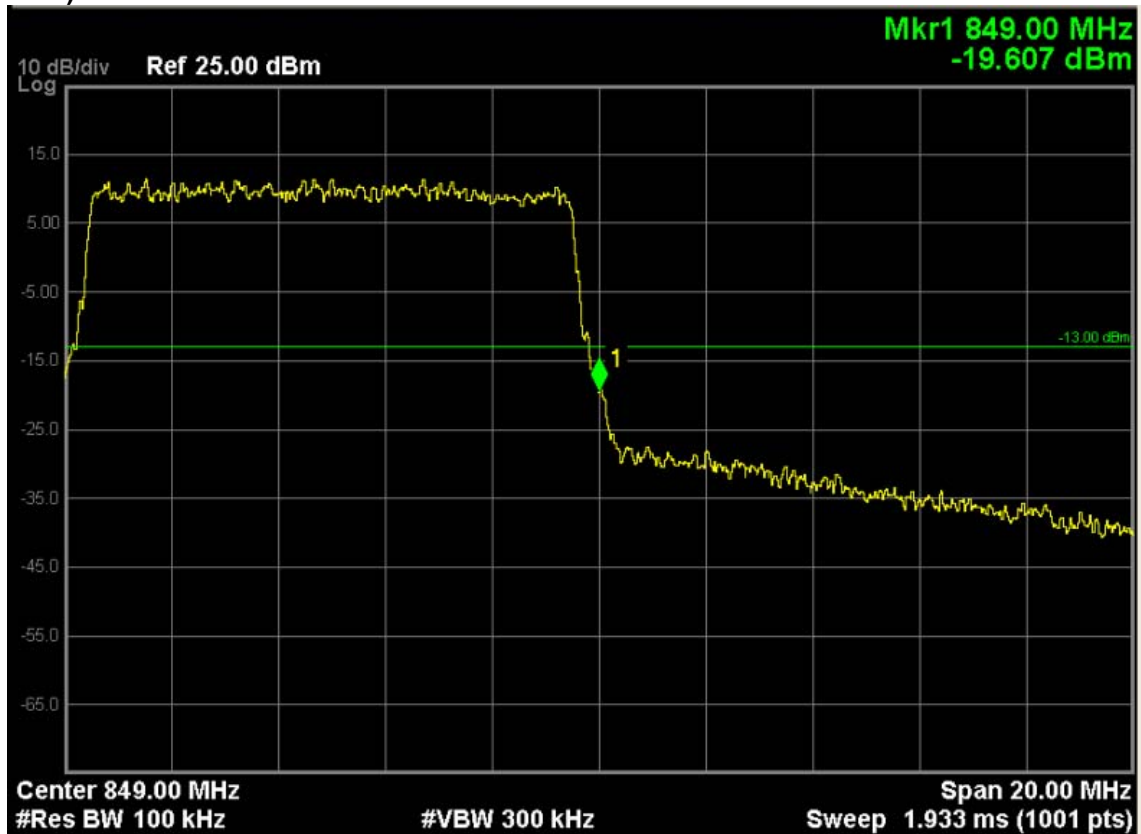

**LTE Band 17 (QPSK, Band Width 5MHz, RB Size 1, RB Offset 0, Channel 23755, Frequency 706.5MHz)**

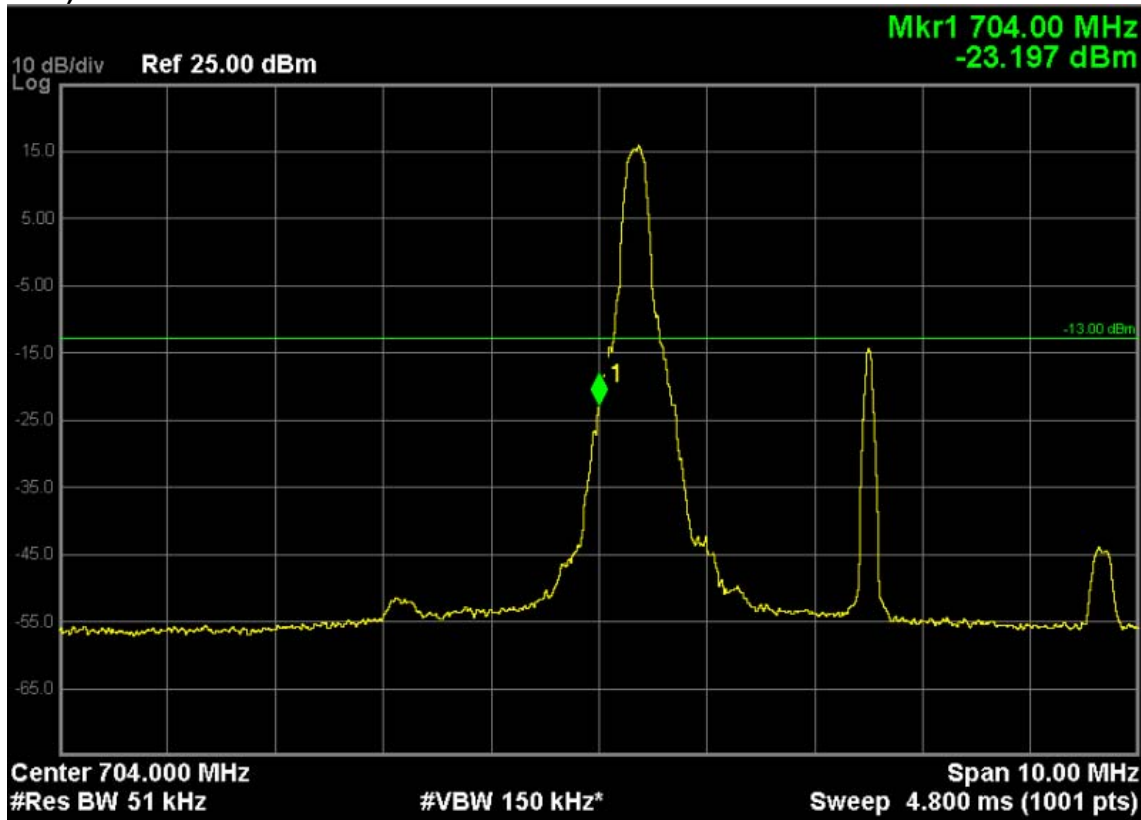

**LTE Band 17 (QPSK, Band Width 5MHz, RB Size 25, RB Offset 0, Channel 23755, Frequency 706.5MHz)**

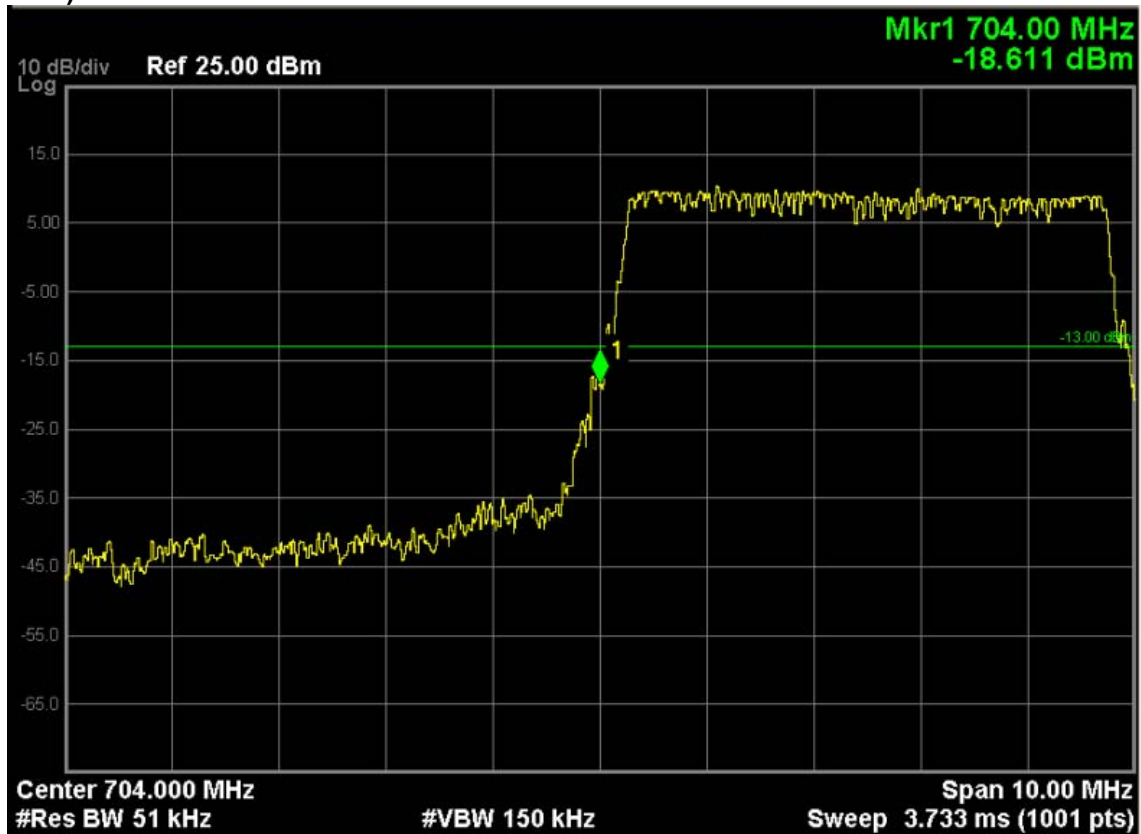

**LTE Band 17 (QPSK, Band Width 5MHz, RB Size 1, RB Offset 24, Channel 23825, Frequency 713.5MHz)**

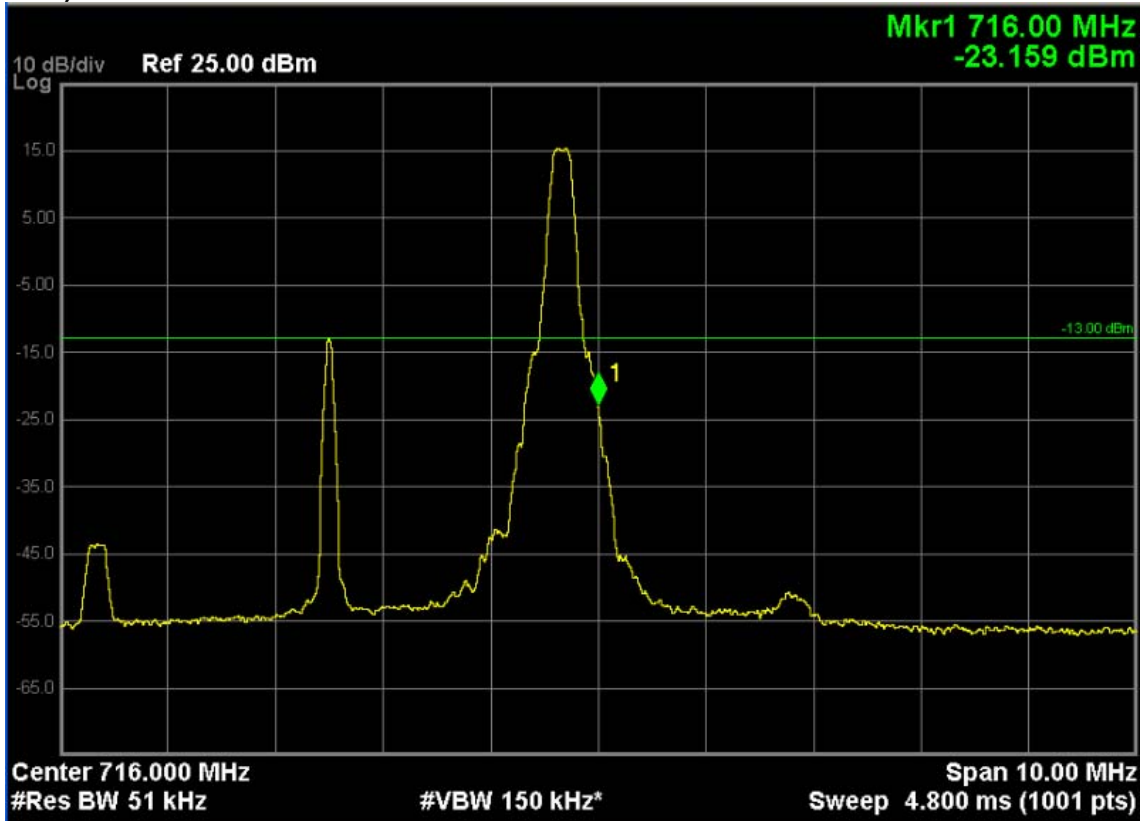

**LTE Band 17 (QPSK, Band Width 5MHz, RB Size 25, RB Offset 0, Channel 23825, Frequency 713.5MHz)**

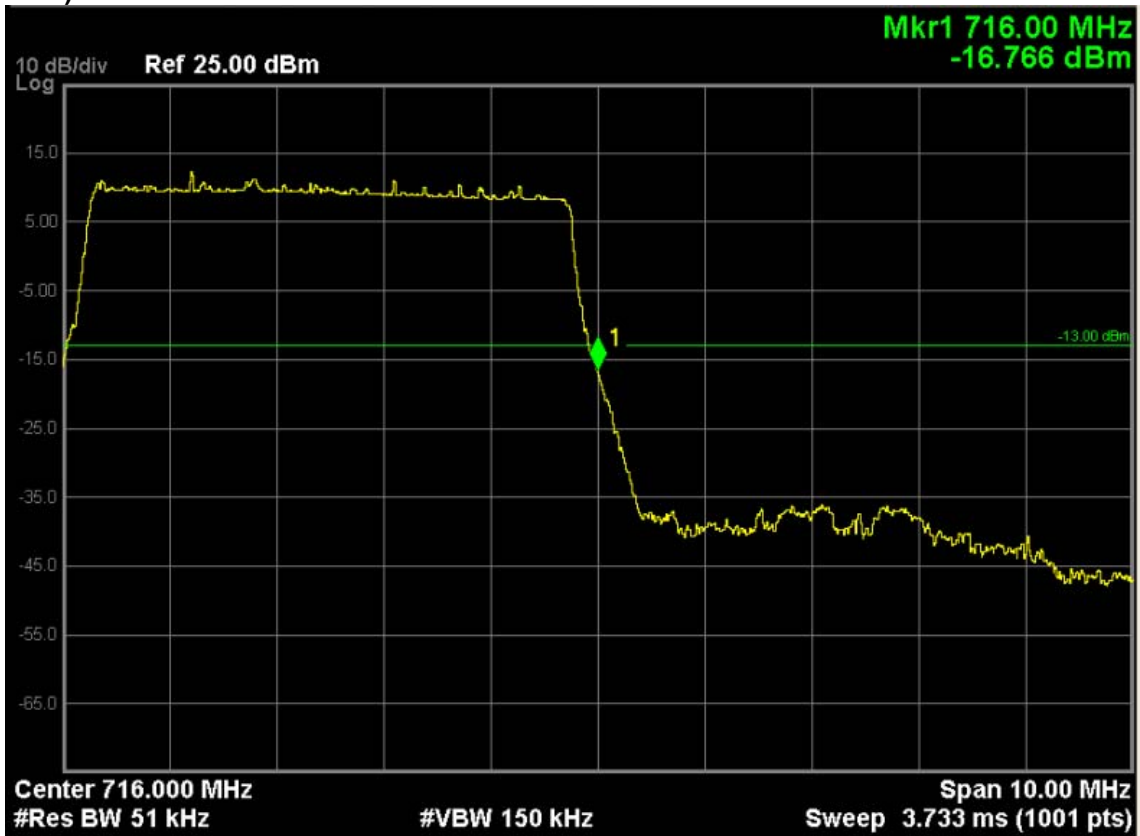

**LTE Band 17 (16-QAM, Band Width 5MHz, RB Size 1, RB Offset 0, Channel 23755, Frequency 706.5MHz)**

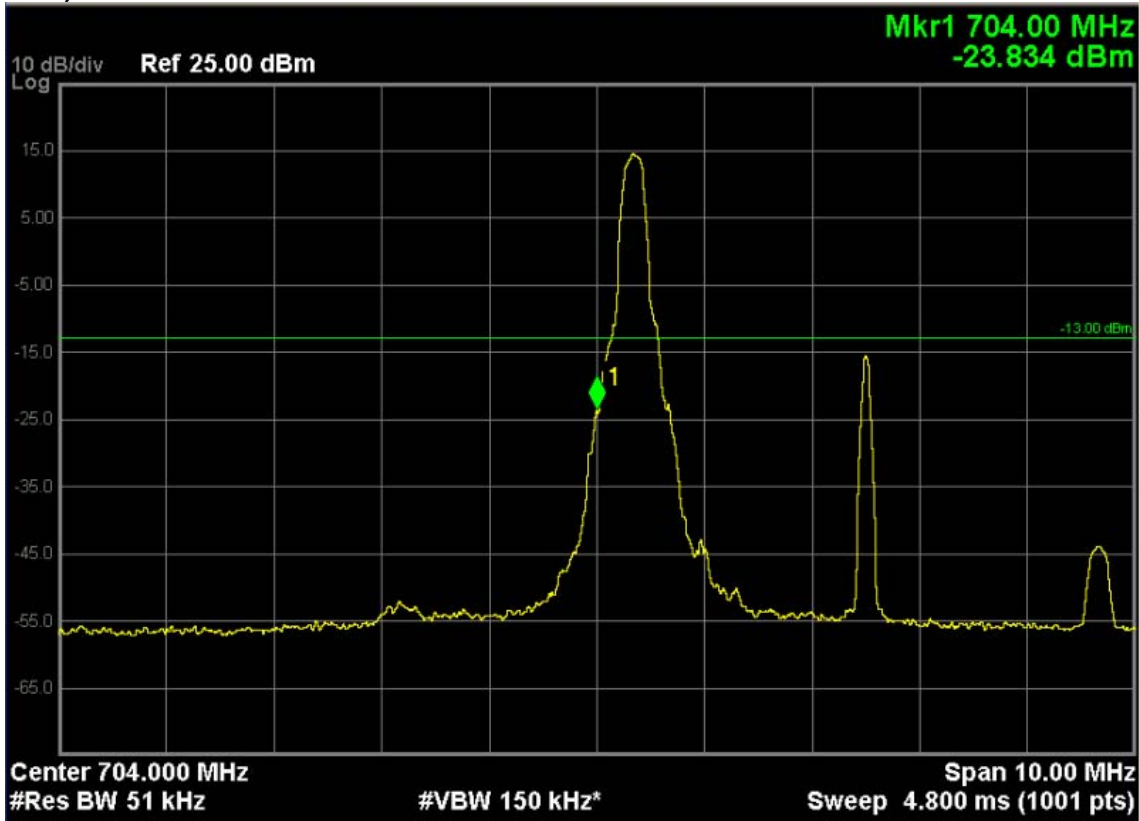

**LTE Band 17 (16-QAM, Band Width 5MHz, RB Size 25, RB Offset 0, Channel 23755, Frequency 706.5MHz)**

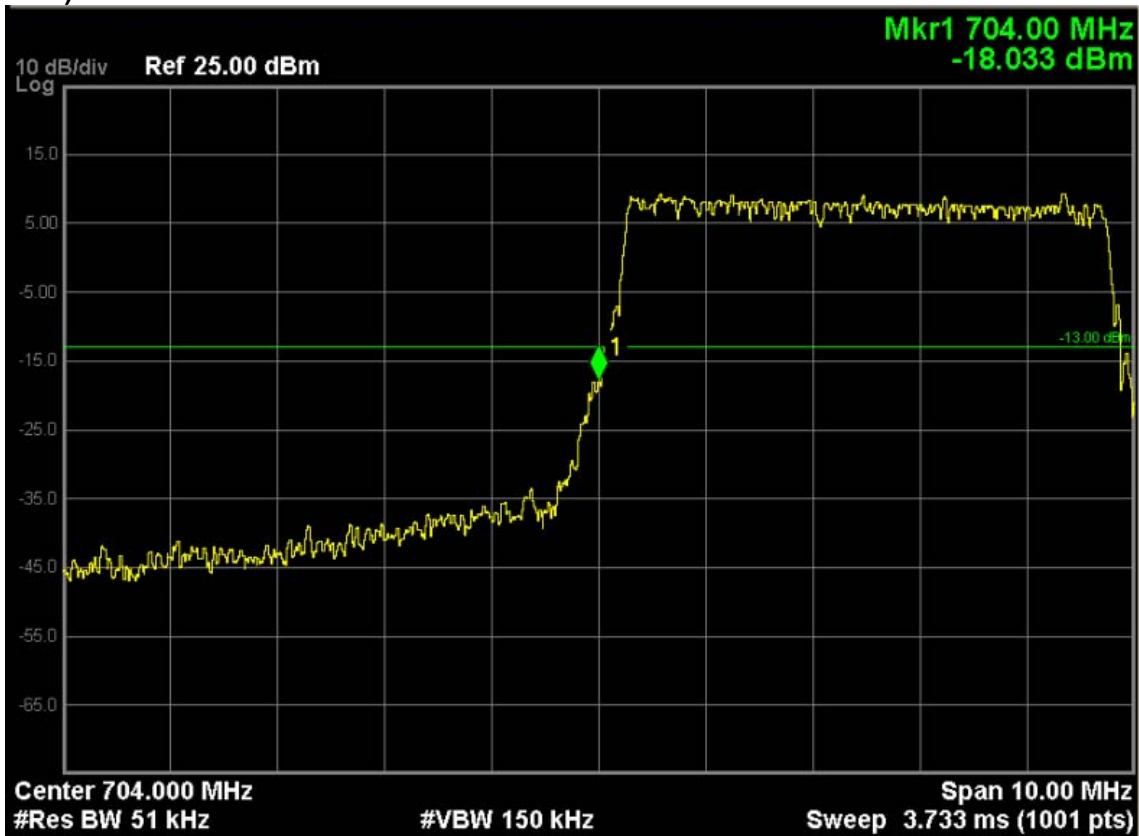



**LTE Band 17 (16-QAM, Band Width 5MHz, RB Size 1, RB Offset 24, Channel 23825, Frequency 713.5MHz)**

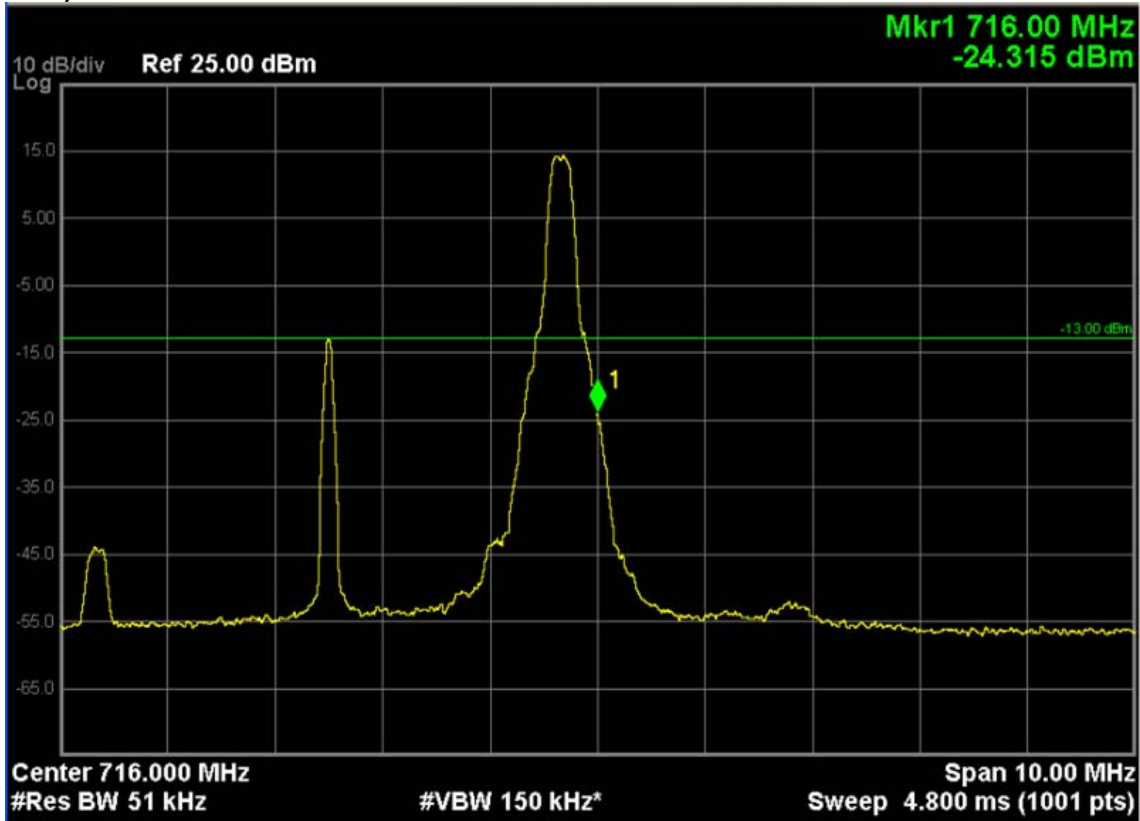

**LTE Band 17 (16-QAM, Band Width 5MHz, RB Size 25, RB Offset 0, Channel 23825, Frequency 713.5MHz)**

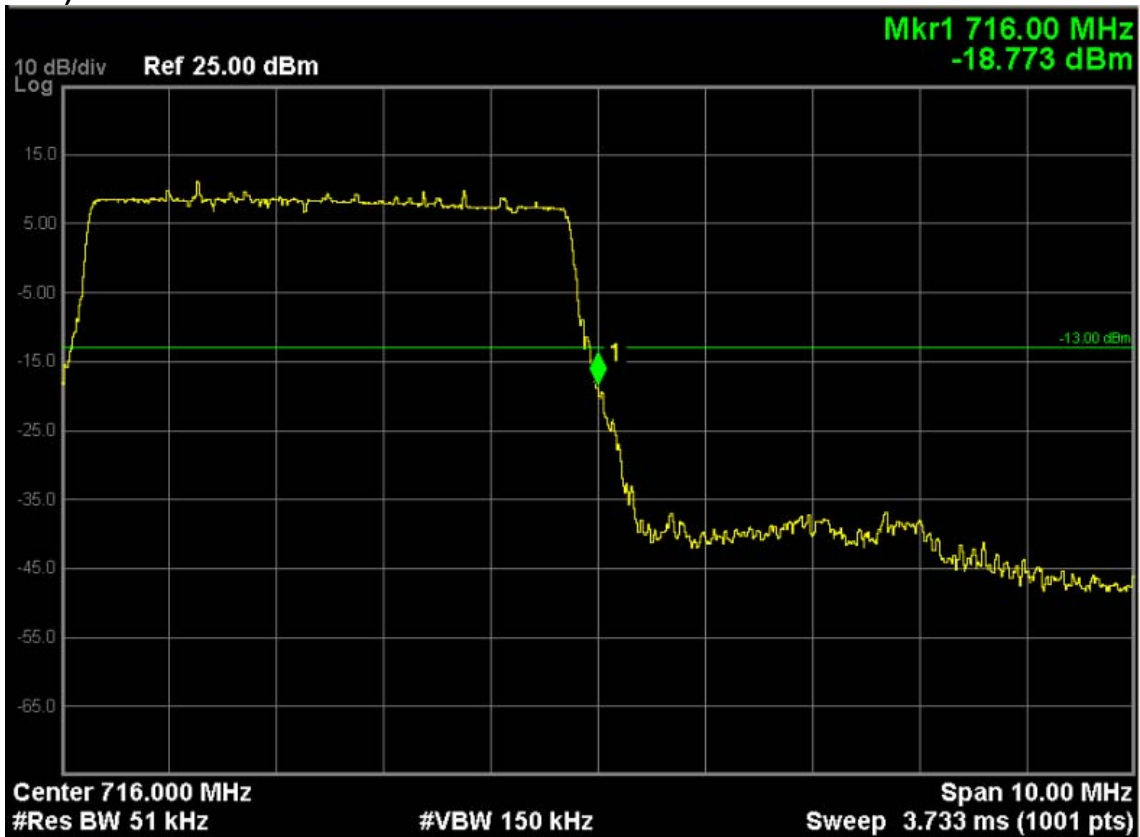

**LTE Band 17 (QPSK, Band Width 10MHz,RB Size 1,RB Offset 0,Channel 23780,Frequeny 709.0MHz)**

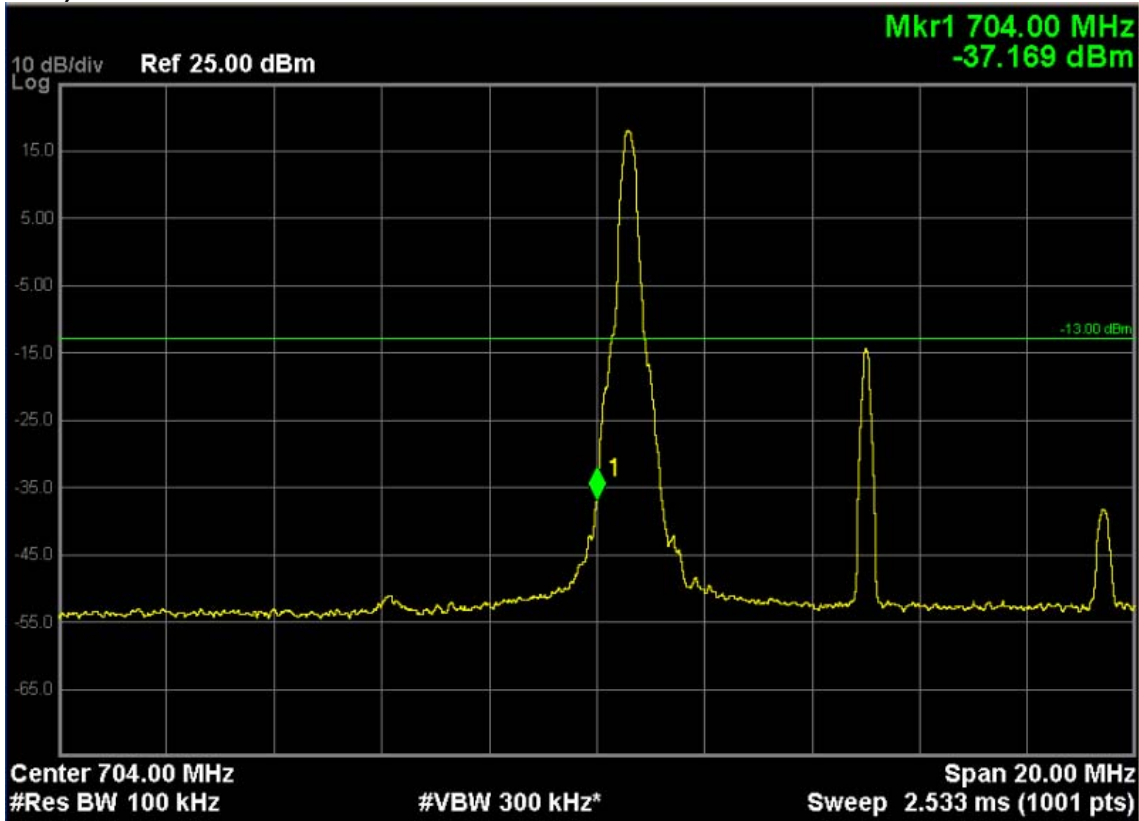

**LTE Band 17 (QPSK, Band Width 10MHz,RB Size 50,RB Offset 0,Channel 23780,Frequeny 709.0MHz)**

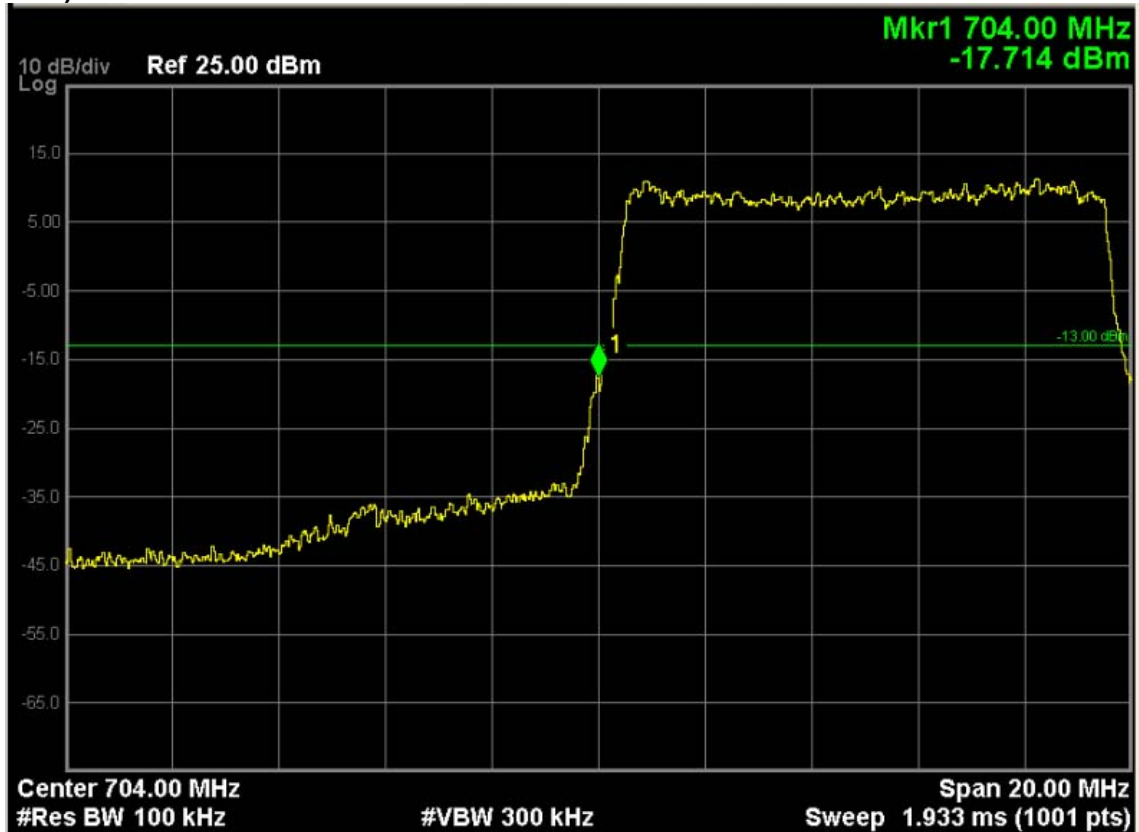

**LTE Band 17 (QPSK, Band Width 10MHz, RB Size 1, RB Offset 49, Channel 23800, Frequency 711.0MHz)**

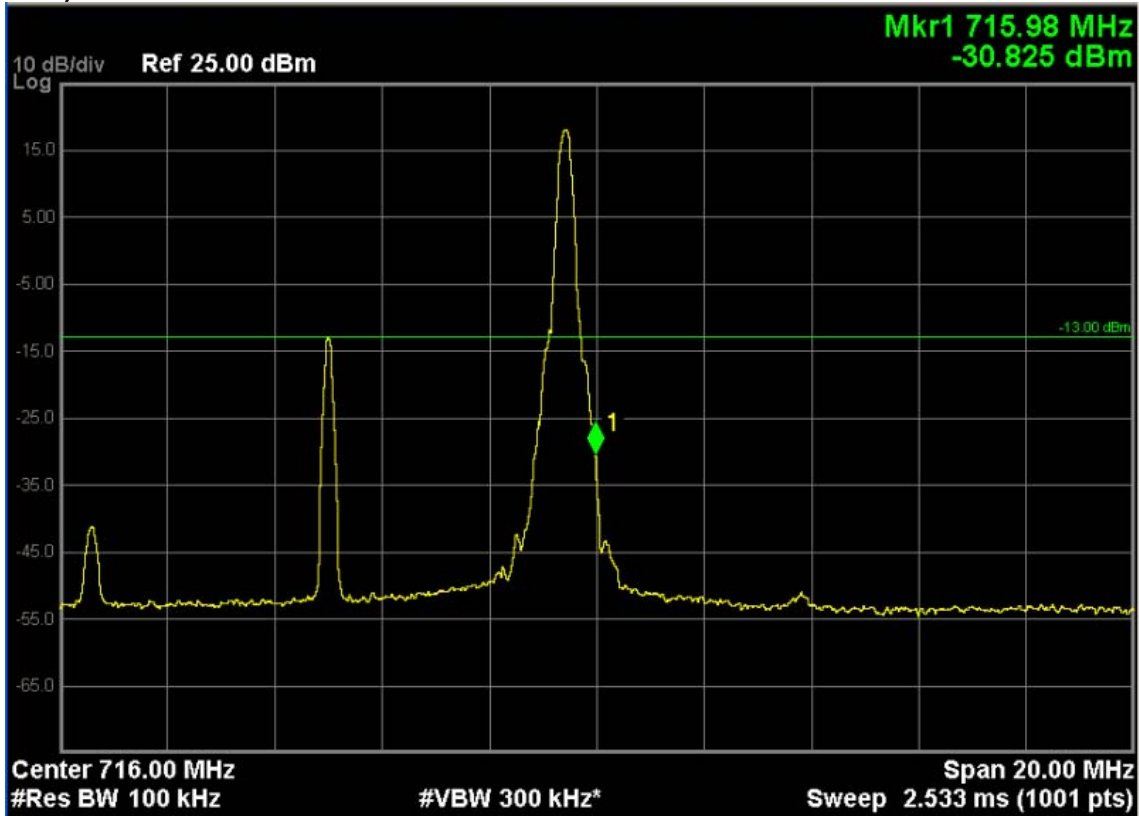

**LTE Band 17 (QPSK, Band Width 10MHz, RB Size 50, RB Offset 0, Channel 23800, Frequency 711.0MHz)**

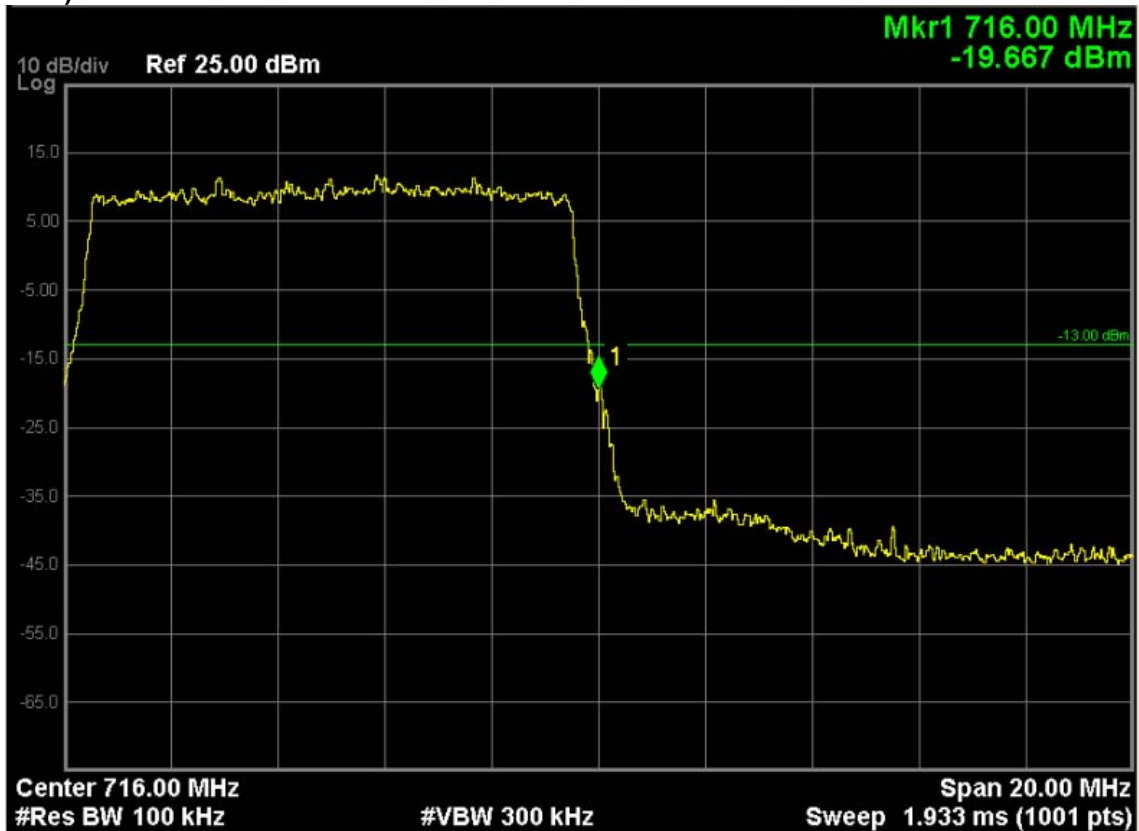

**LTE Band 17 (16-QAM, Band Width 10MHz, RB Size 1, RB Offset 0, Channel 23780, Frequency 709.0MHz)**

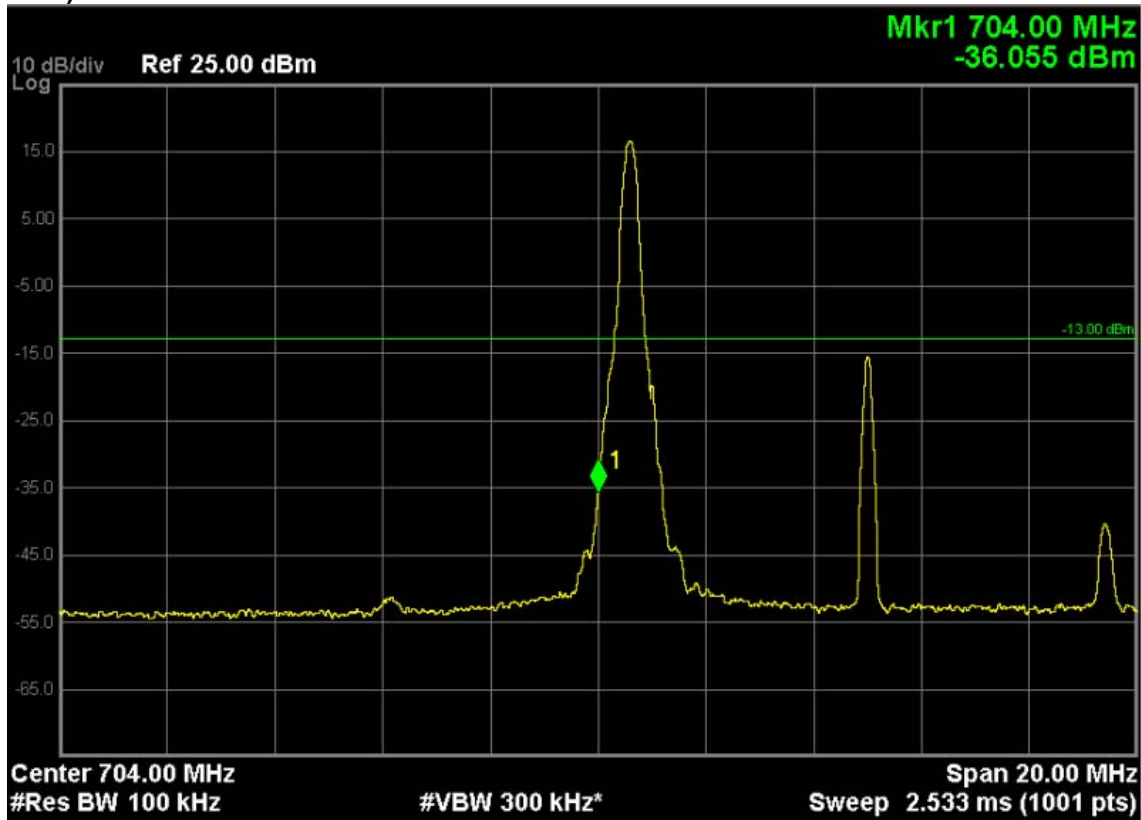

**LTE Band 17 (16-QAM, Band Width 10MHz, RB Size 50, RB Offset 0, Channel 23780, Frequency 709.0MHz)**

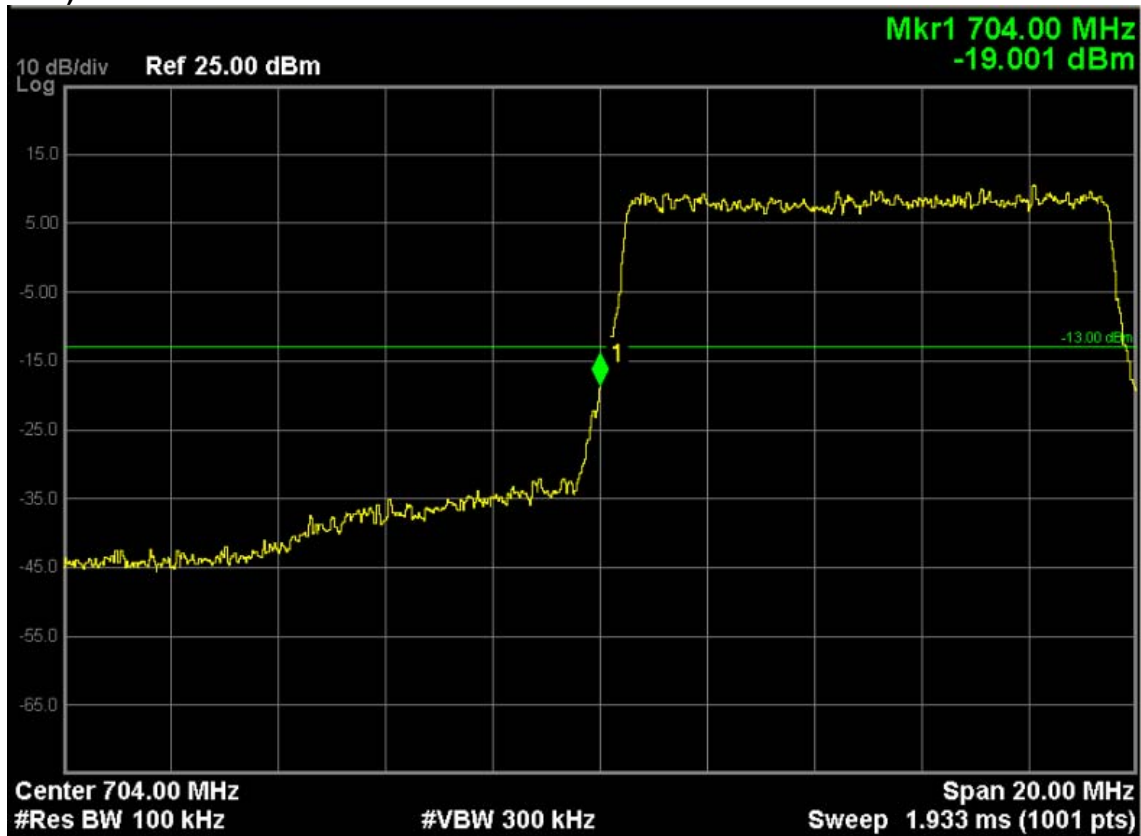

**LTE Band 17 (16-QAM, Band Width 10MHz, RB Size 1, RB Offset 49, Channel 23800, Frequency 711.0MHz)**

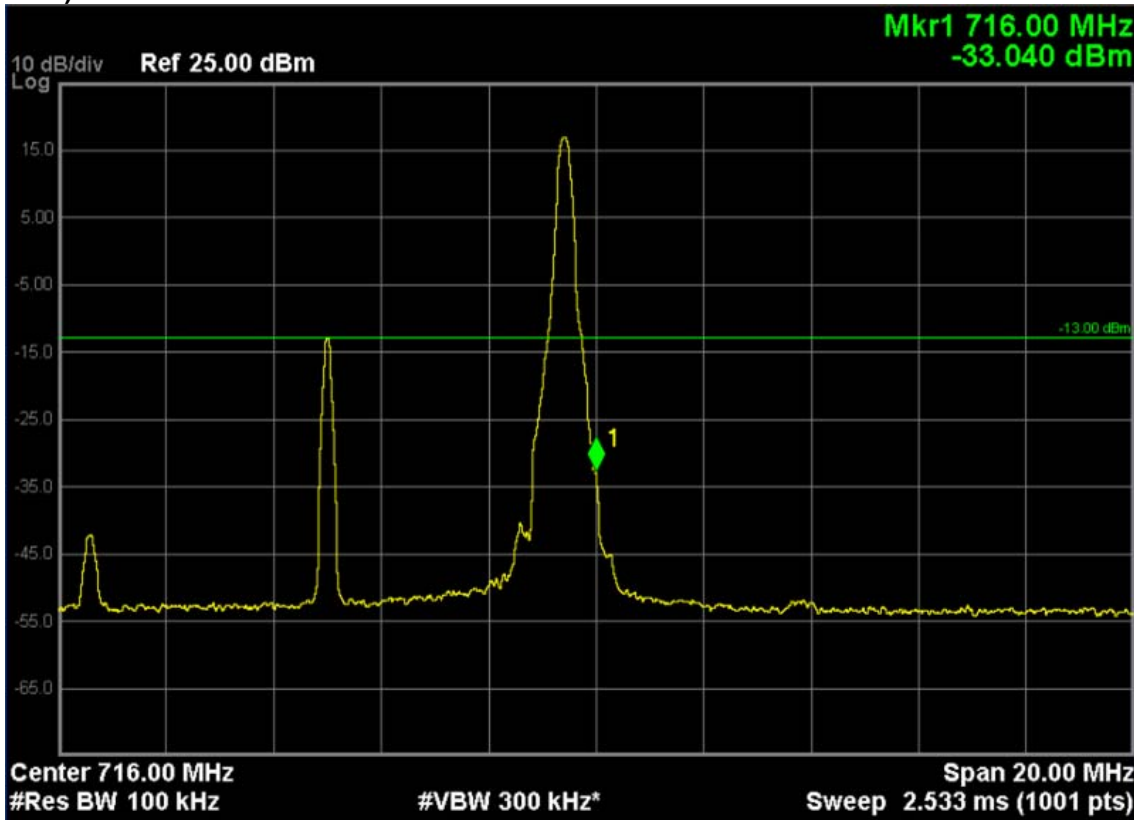

**LTE Band 17 (16-QAM, Band Width 10MHz, RB Size 50, RB Offset 0, Channel 23800, Frequency 711.0MHz)**

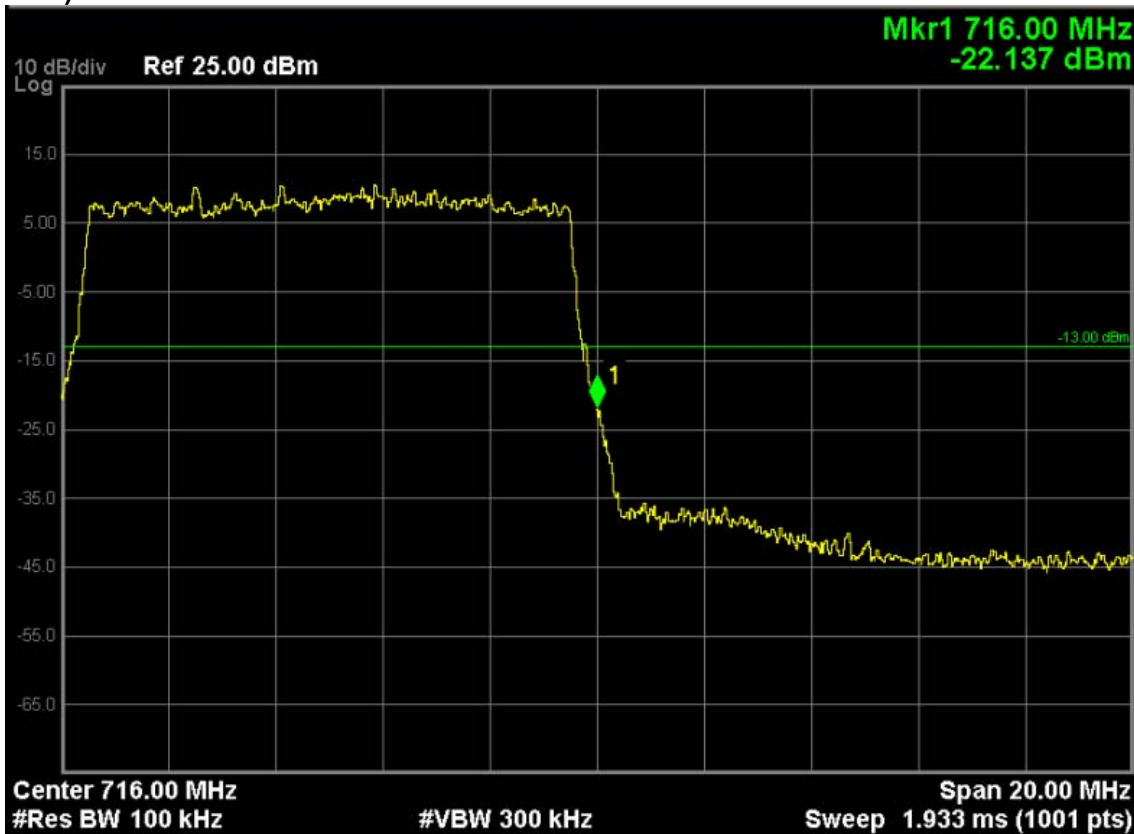

## 6.Spurious Emission

### 6.1. Test Equipment

Instrument	Manufacturer	Model	Serial No.	Cali. Due Date
Spectrum Analyzer	Agilent	N9038A	MY51210142	12/17/2014
Radio Communication Tester	R&S	CMW500	147483	10/15/2015
Signal Generator	Agilent	N5183A	MY50140938	01/03/2015
Preamplifier	CEM	EM30180	3008A0245	02/28/2015
Loop Antenna	Schwarzbeck	FMZB1519	1519-020	03/26/2015
Bilog Antenna	Schwarzbeck	VULB9160	9160-3316	10/19/2015
VHF-UHF-Biconical Antenna	Schwarzbeck	VUBA9117	9117-263	10/19/2015
Broad-Band Horn Antenna	Schwarzbeck	BBHA9120D	9120D-942	10/19/2015
Broad-Band Horn Antenna	Schwarzbeck	BBHA9120D	9120D-943	10/19/2015

The measure equipment had been calibrated once a year.

## 6.2. Test Setup

Conducted Spurious Emission Measurement:

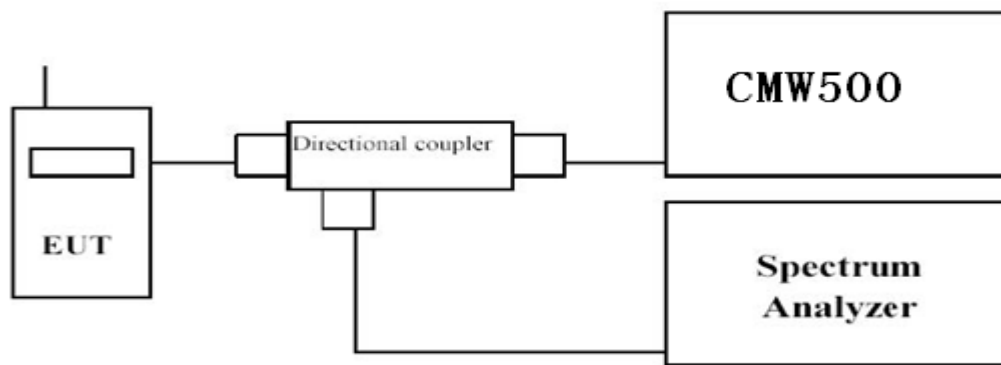

Radiated Spurious Measurement: below 30MHz

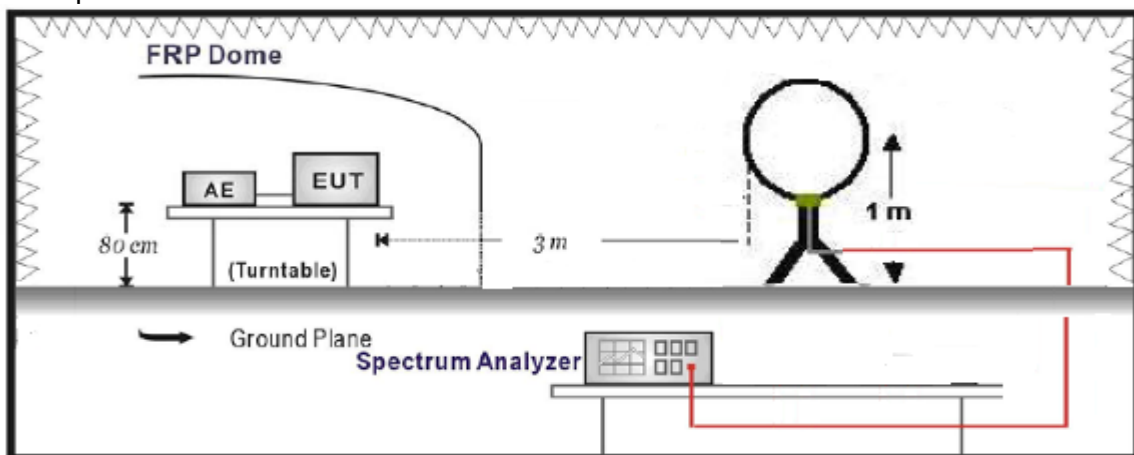

Radiated Spurious Measurement: 30MHz to 1GHz

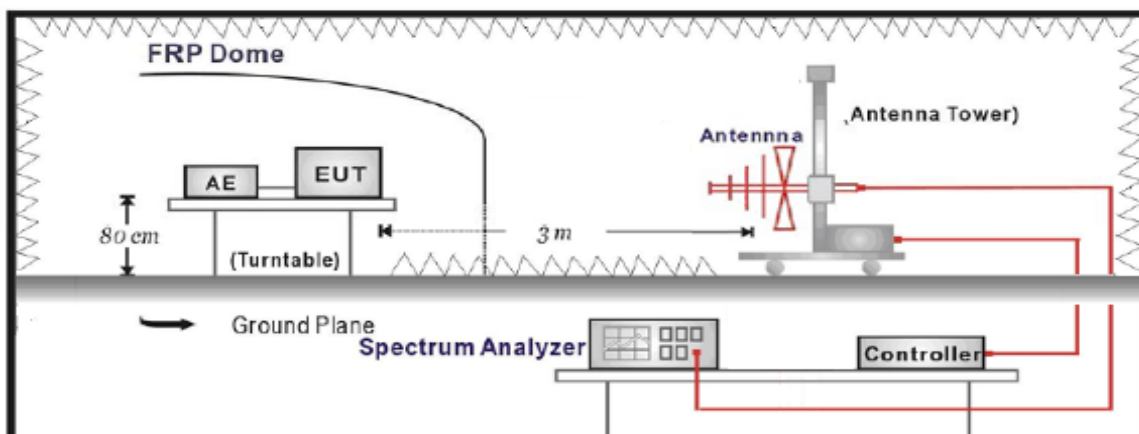

### Radiated Spurious Measurement: above 1GHz

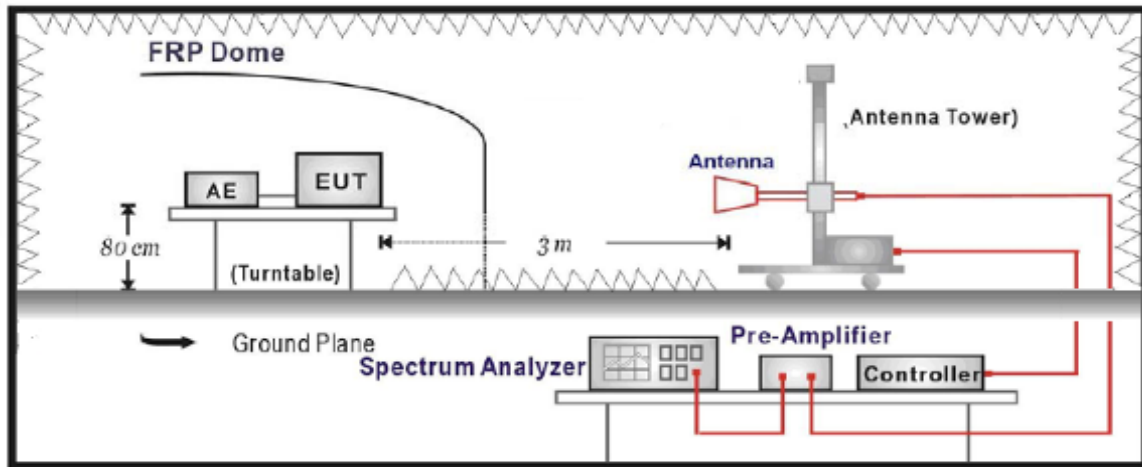

### 6.3. Limit

The power of any emission outside of the authorized operating frequency ranges must be attenuated below the transmitting power (P) by a factor of at least  $43 + 10\log(P)$  dB.

### 6.4. Test Procedure

#### Conducted Spurious Measurement:

- The testing follows FCC KDB 972268 v02v02 Section 6.0;
- Place the EUT on a bench and set it in transmitting mode.
- Connect a low loss RF cable from the antenna port to a spectrum analyzer and CMW500 by a Directional Coupler.
- EUT Communicate with CMW500, then select a channel for testing.
- Add a correction factor to the display of spectrum, and then test.
- The resolution bandwidth of the spectrum analyzer was set at 1 MHz, sufficient scans were taken to show the out of band Emission if any up to 10th harmonic.

#### Radiated Spurious Measurement:

- The testing follows FCC KDB 972268 v02v02 Section 5.8 and ANSI/TIA-603-C-2004 Section 2.2.12;
- The EUT shall be placed at the specified height on a support, and in the position closest to normal use as declared by provider.
- The test antenna shall be oriented initially for vertical polarization and shall be chosen to correspond to the frequency of the transmitter
- The output of the test antenna shall be connected to the measuring receiver. The transmitter shall be switched on and the measuring receiver shall be tuned to the frequency of the transmitter under test.
- The test antenna shall be raised and lowered through the specified range of height until a



maximum signal level is detected by the measuring receiver.

- f. The transmitter shall then be rotated through  $360^\circ$  in the horizontal plane, until the maximum signal level is detected by the measuring receiver.
- g. The test antenna shall be raised and lowered again through the specified range of height until a maximum signal level is detected by the measuring receiver.
- h. The maximum signal level detected by the measuring receiver shall be noted.
- i. The transmitter shall be replaced by a substitution antenna.
- j. The substitution antenna shall be orientated for vertical polarization and the length of the substitution antenna shall be adjusted to correspond to the frequency of the transmitter.
- k. The substitution antenna shall be connected to a calibrated signal generator.
- l. If necessary, the input attenuator setting of the measuring receiver shall be adjusted in order to increase the sensitivity of the measuring receiver.
- m. The test antenna shall be raised and lowered through the specified range of height to ensure that the maximum signal is received.
- n. The input signal to the substitution antenna shall be adjusted to the level that produces a level detected by the measuring receiver, that is equal to the level noted while the transmitter radiated power was measured, corrected for the change of input attenuator setting of the measuring receiver.
- o. The measurement shall be repeated with the test antenna and the substitution antenna orientated for horizontal polarization.
- p. The measure of the effective radiated power is the larger of the two levels recorded at the input to the substitution antenna, corrected for gain of the substitution antenna if necessary.
- q. The frequency range was checked up to 10<sup>th</sup> harmonic.

## **6.5. Uncertainty**

The measurement uncertainty is defined as 3.2 dB for Radiated Power Measurement.

### 6.6. Test Result

#### Conducted Spurious Measurement:

LTE Band 2 (QPSK, Band Width 1.4MHz,RB Size 1,RB Offset 0,Channel 18900,Frequeny 1880.0MHz)

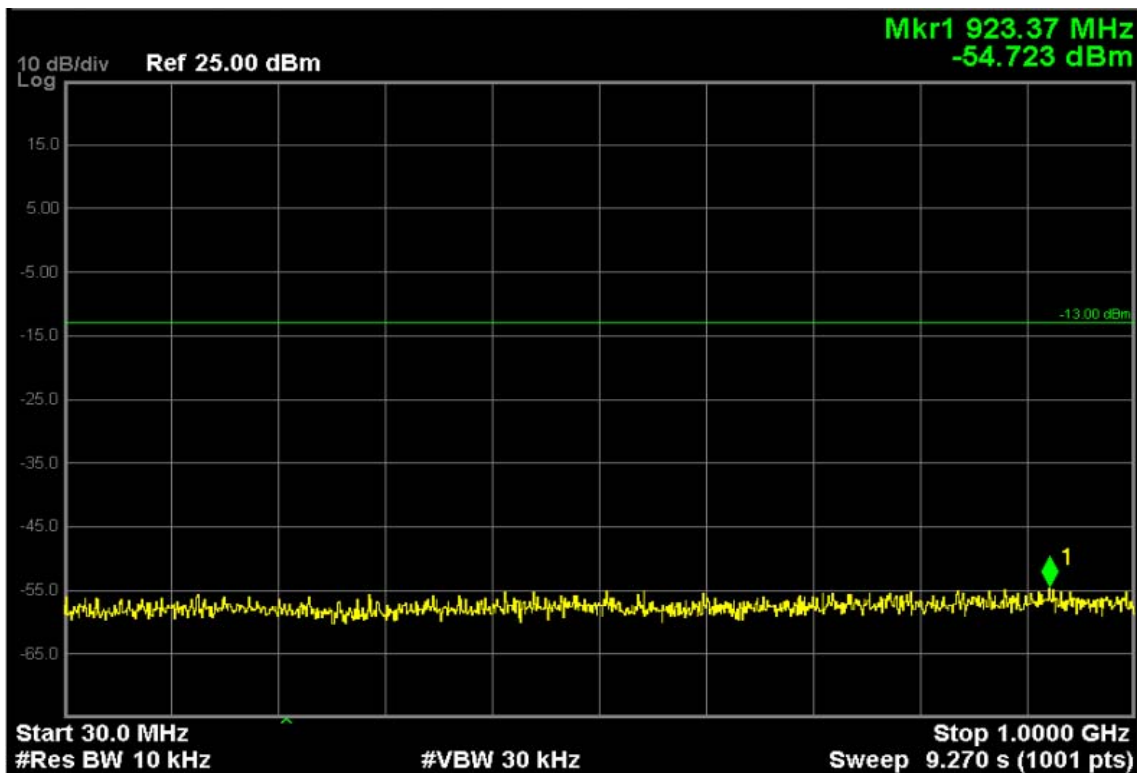
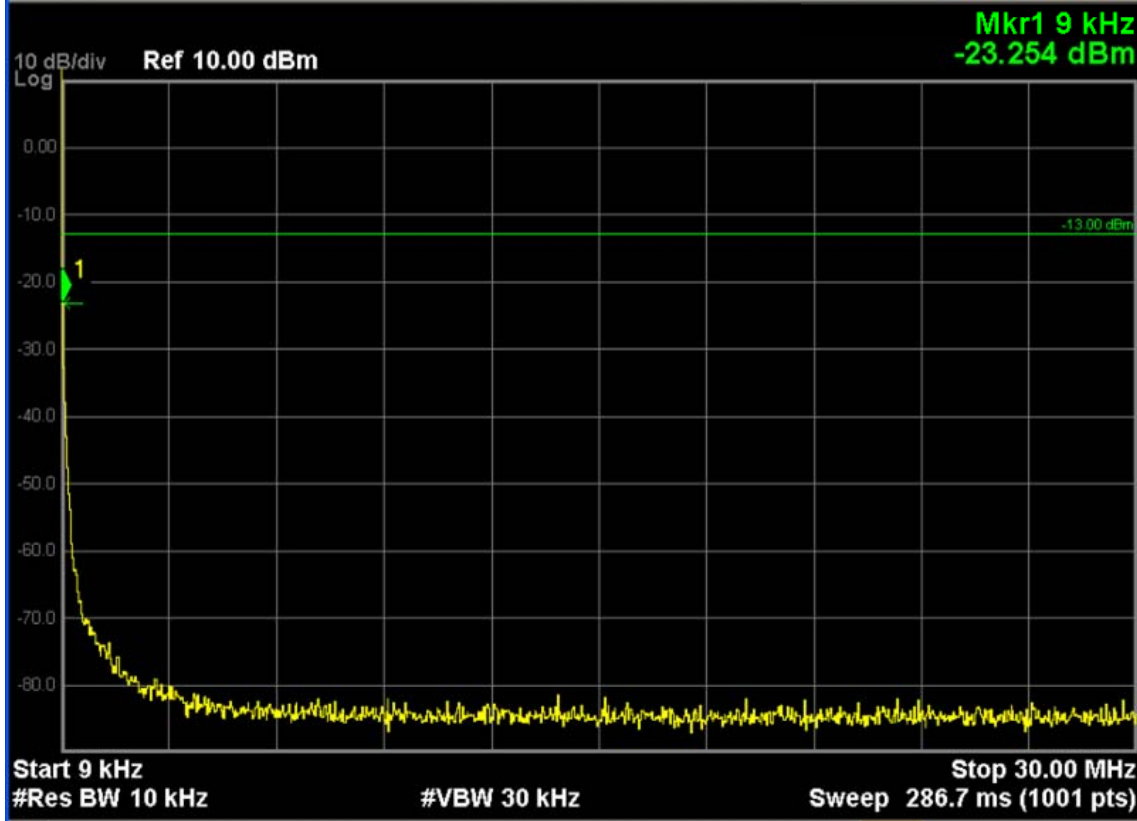

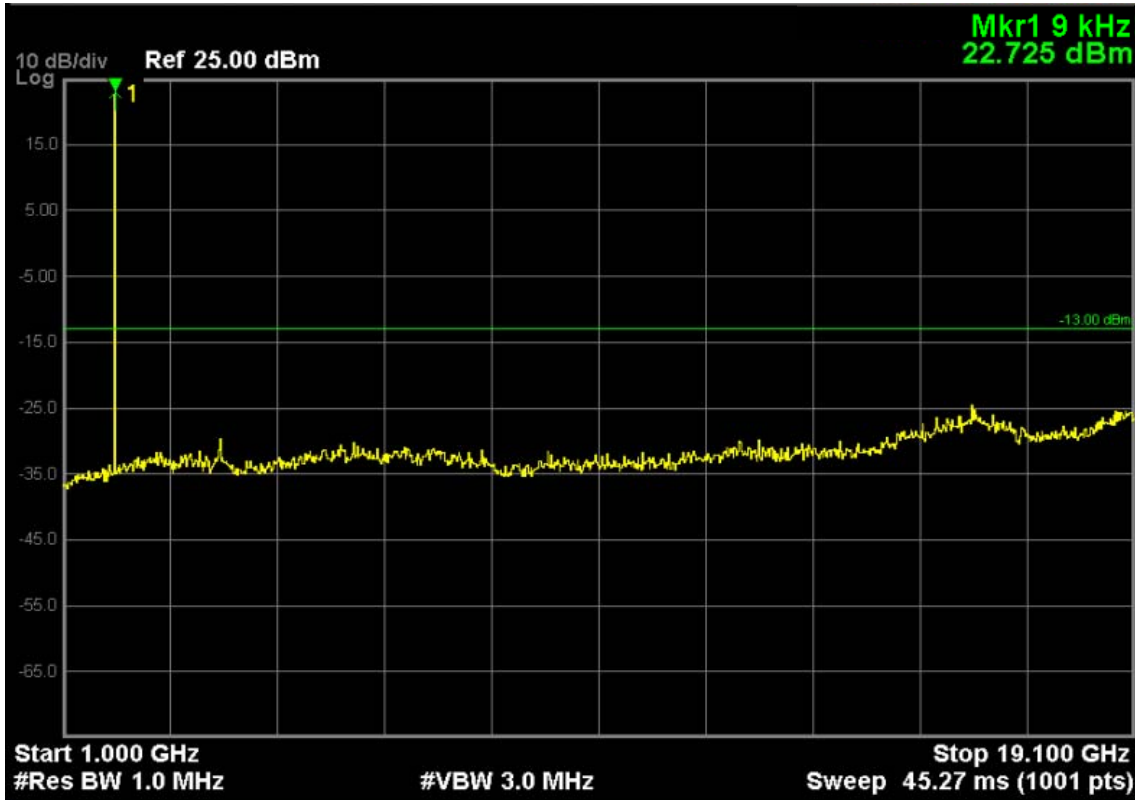

Note: The signal at point 1 is carrier

LTE Band 2 (16-QAM, Band Width 1.4MHz, RB Size 1, RB Offset 5, Channel 18607, Frequency 1850.7MHz)

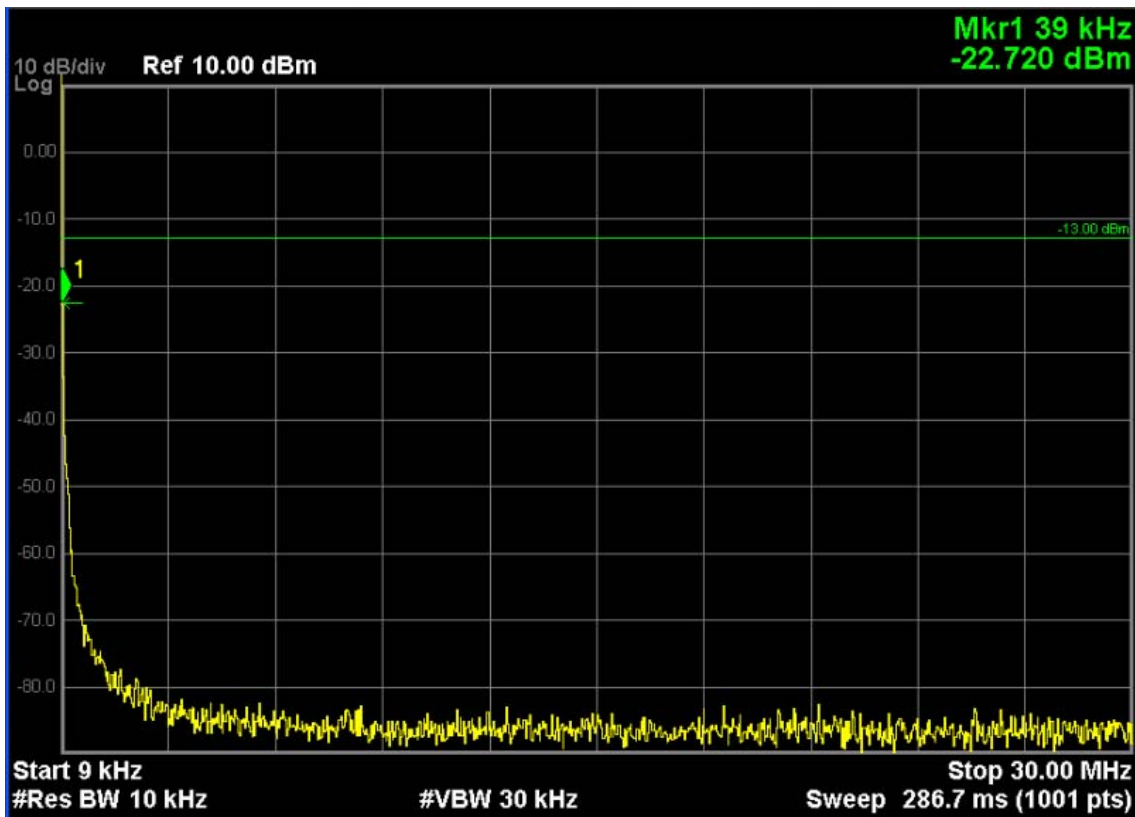

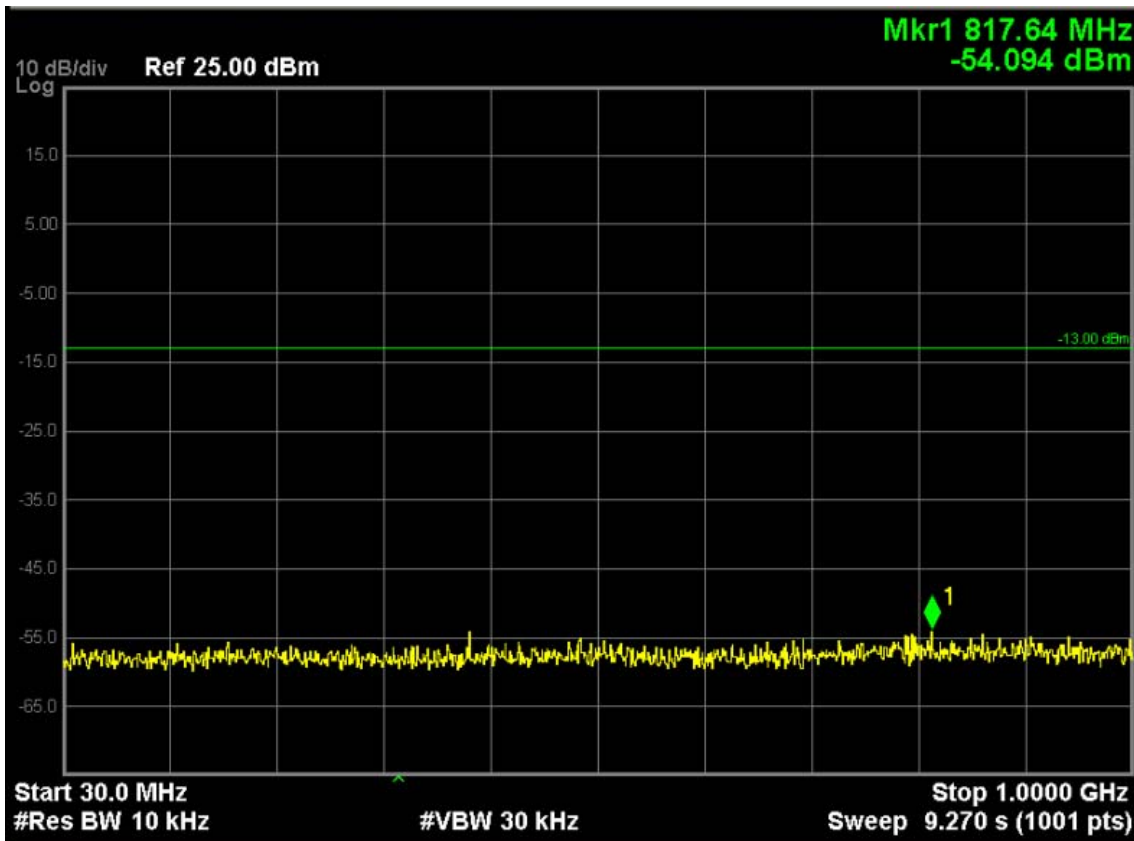

Note: The signal at point 1 is carrier

**LTE Band 2 (QPSK, Band Width 3MHz, RB Size 1, RB Offset 0, Channel 18900, Frequency 1880.0MHz)**

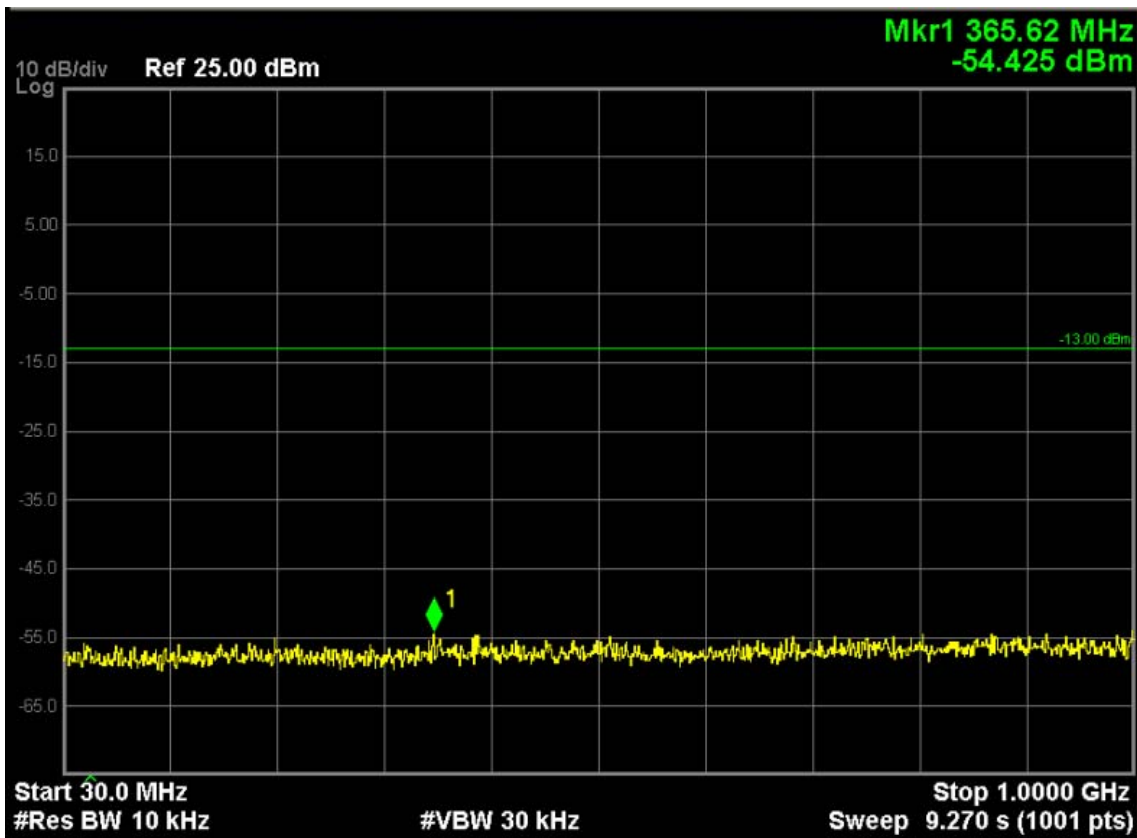
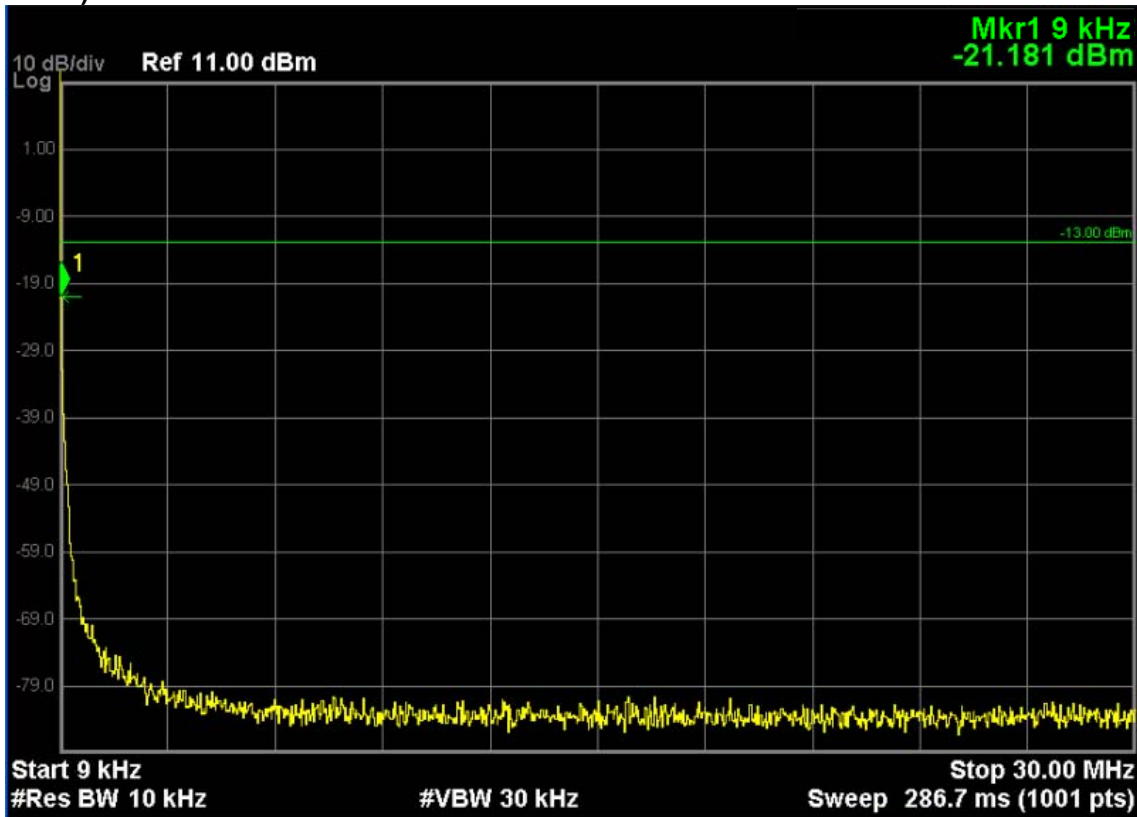

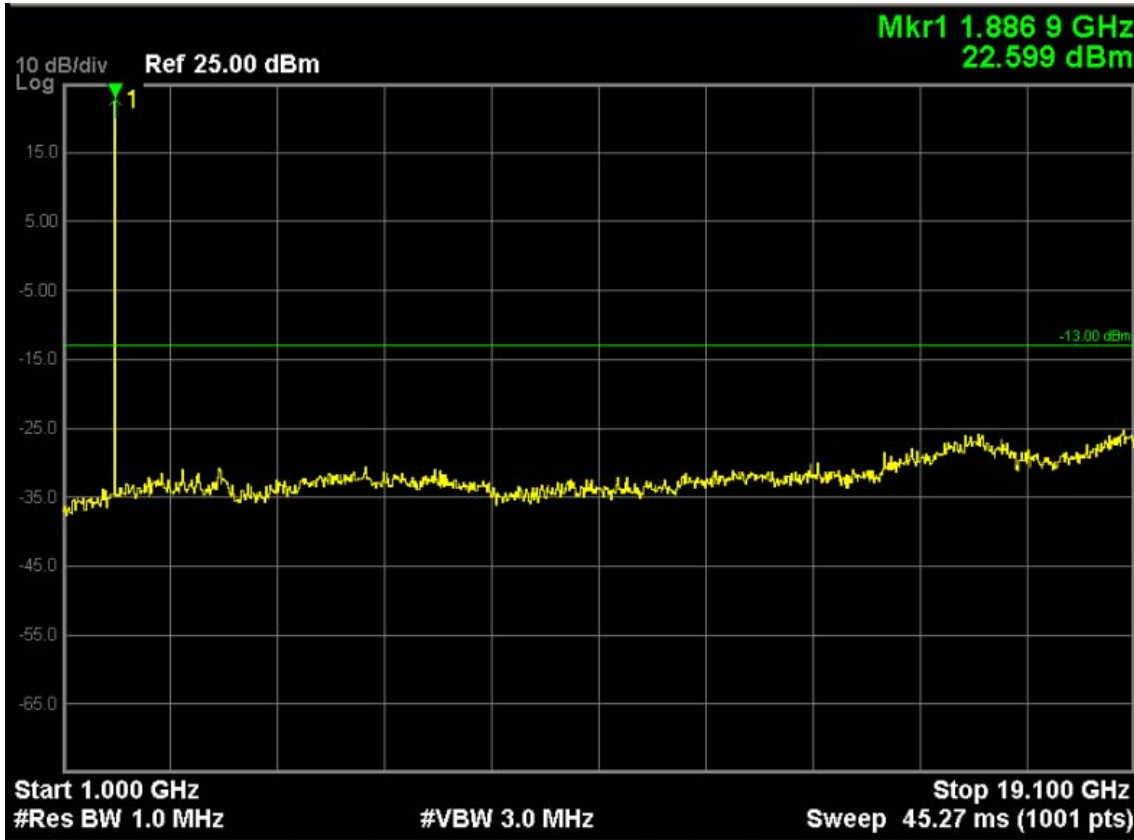

Note: The signal at point 1 is carrier

LTE Band 2 (16-QAM, Band Width 3MHz, RB Size 1, RB Offset 0, Channel 18900, Frequency 1880.0MHz)

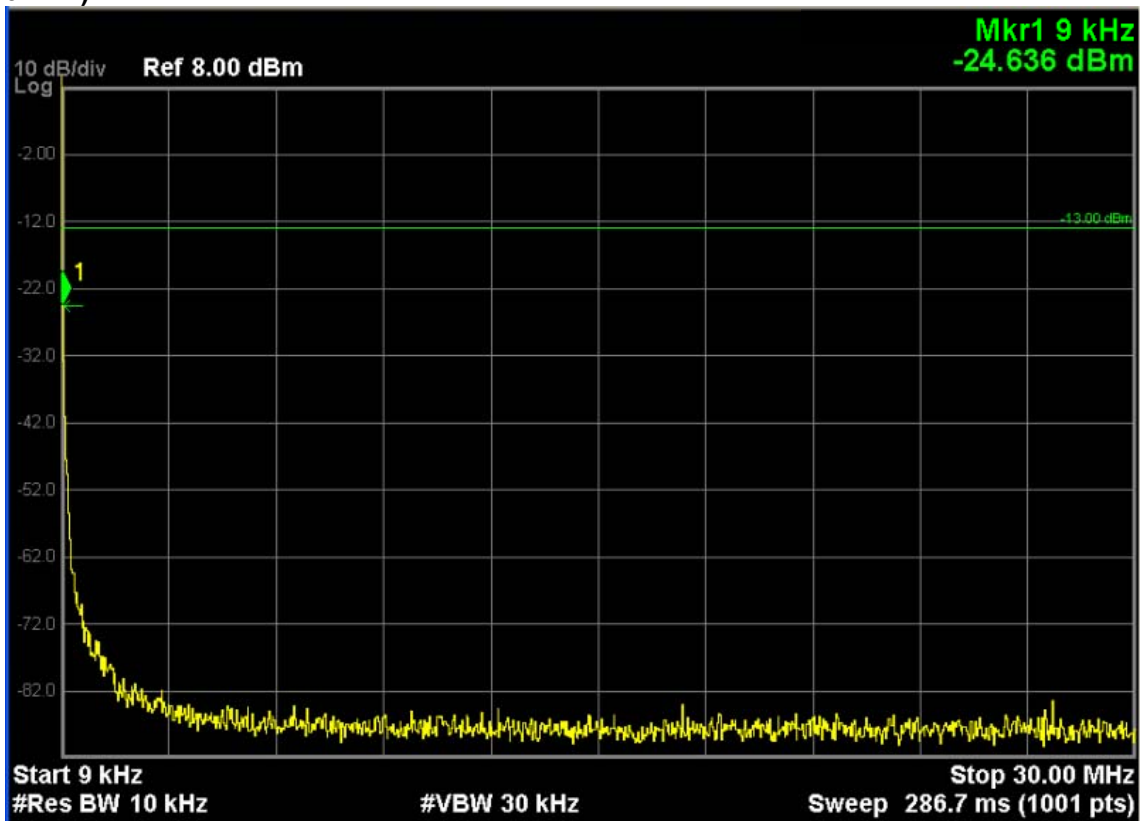

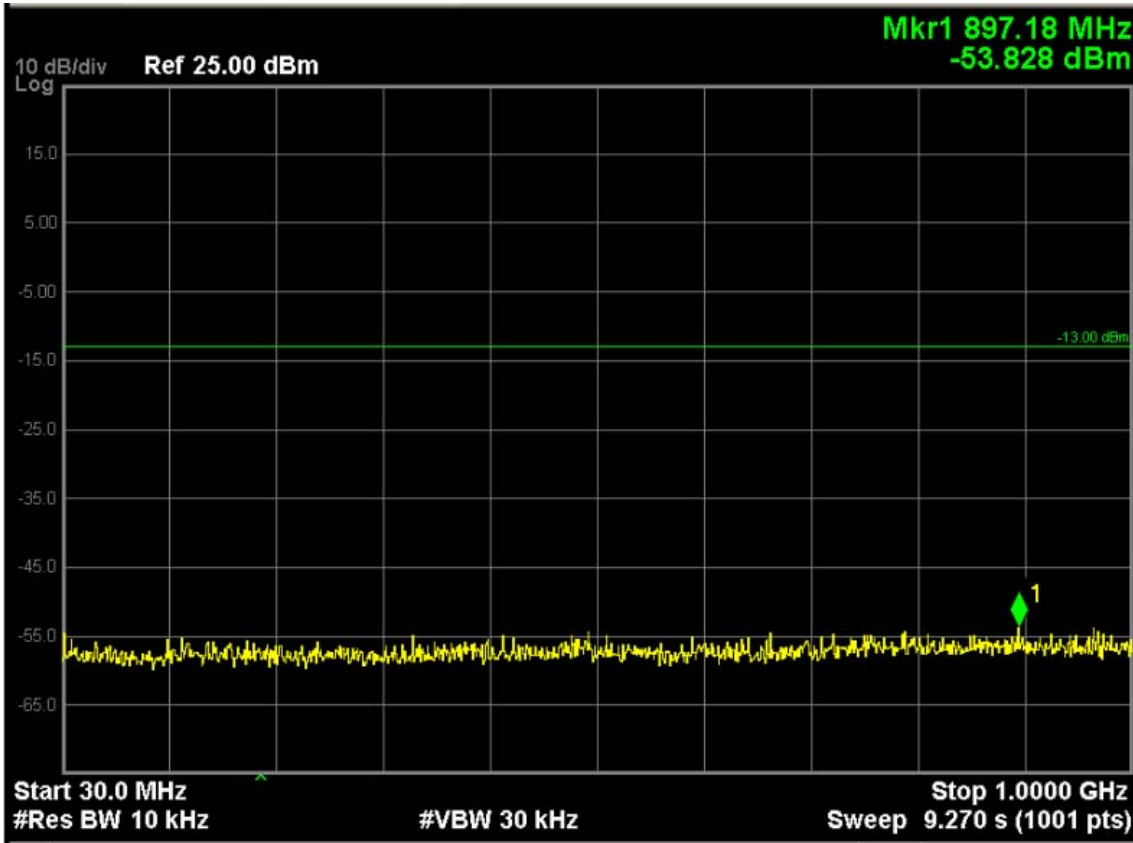

Note: The signal at point 1 is carrier

**LTE Band 2 (QPSK, Band Width 5MHz, RB Size 1, RB Offset 24, Channel 18625, Frequency 1852.5MHz)**

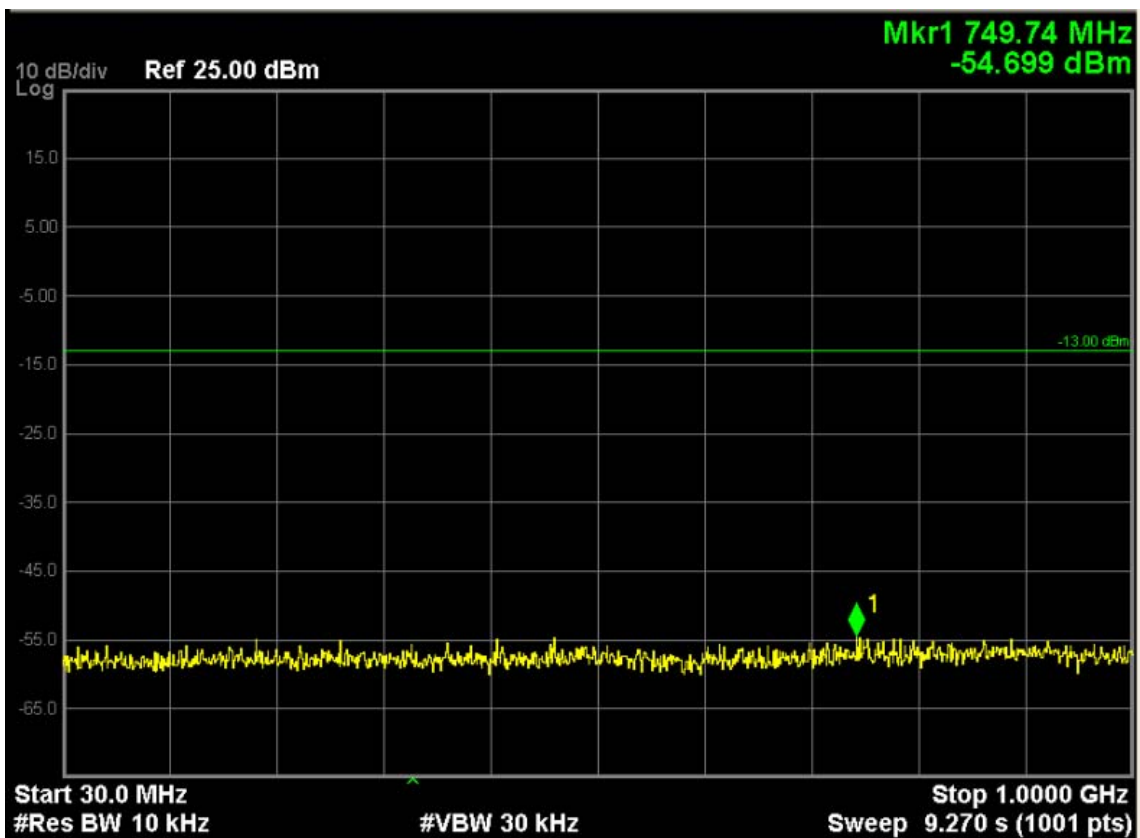
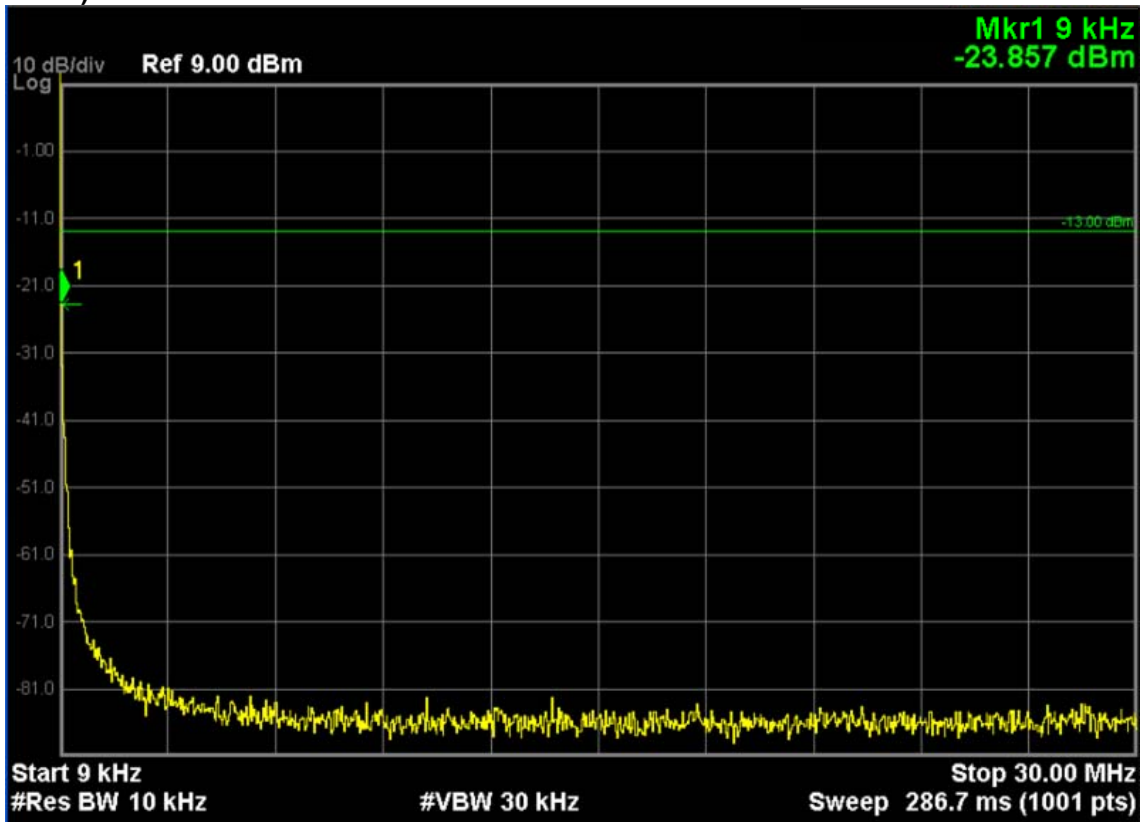



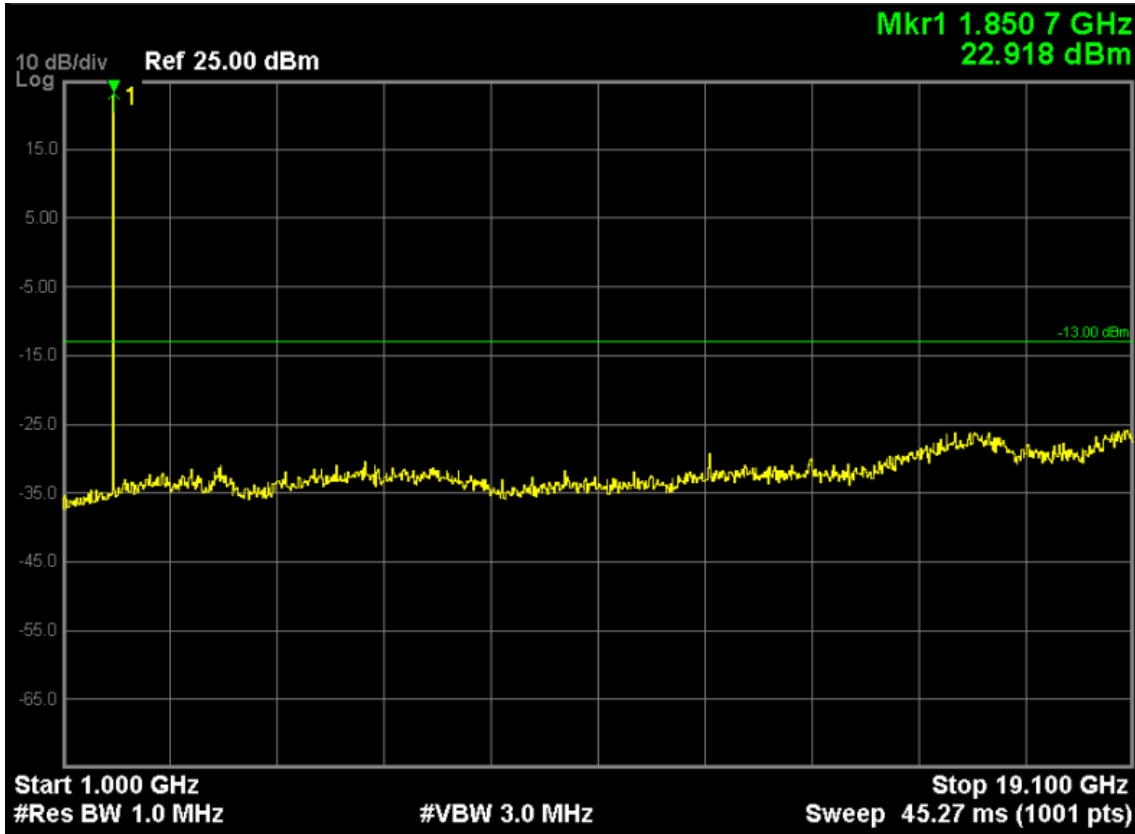

Note: The signal at point 1 is carrier

LTE Band 2 (16-QAM, Band Width 5MHz, RB Size 1, RB Offset 24, Channel 18625, Frequency 1852.5MHz)

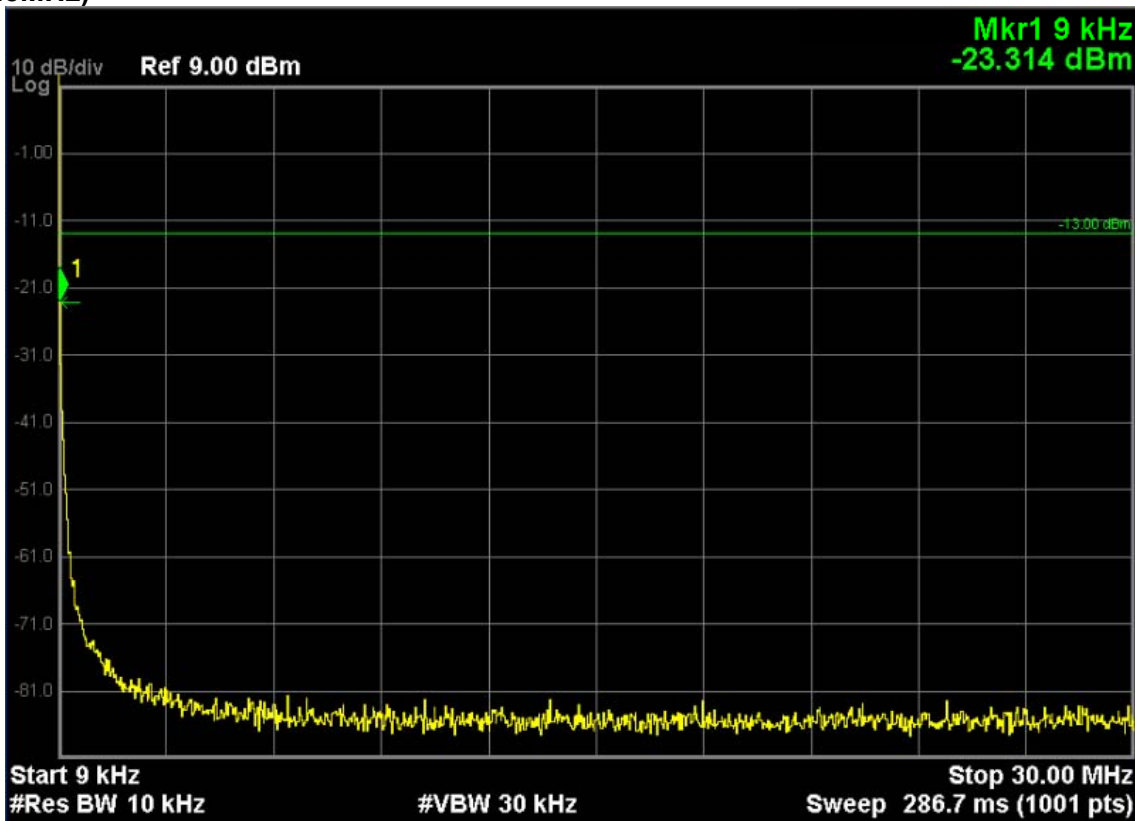

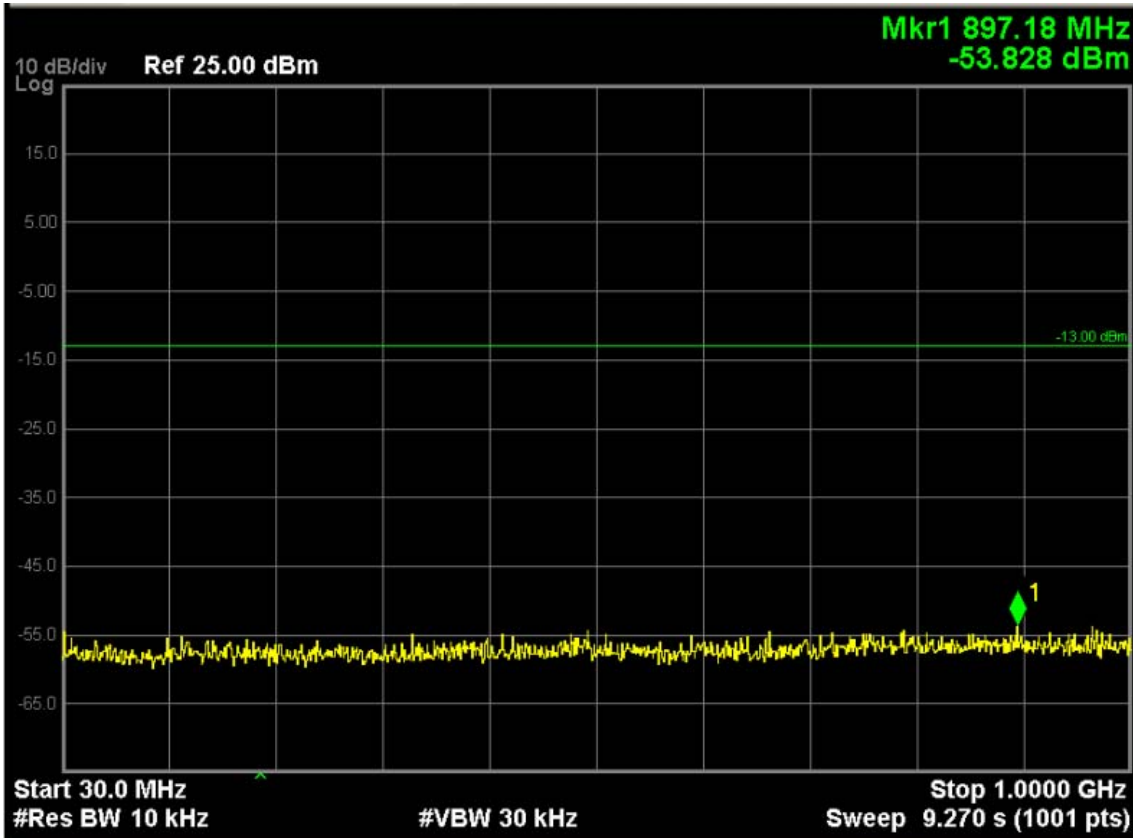

Note: The signal at point 1 is carrier

**LTE Band 2 (QPSK, Band Width 10MHz,RB Size 1,RB Offset 49,Channel 18650,Frequency 1855.0MHz)**

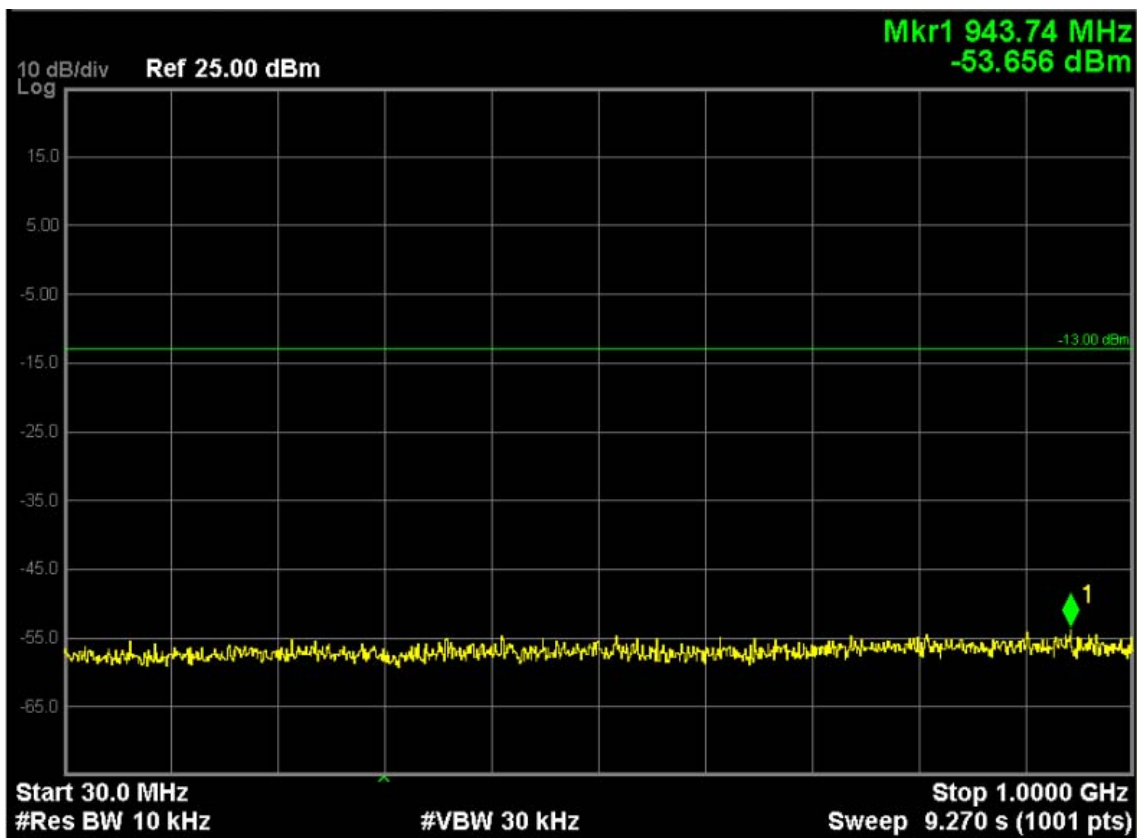
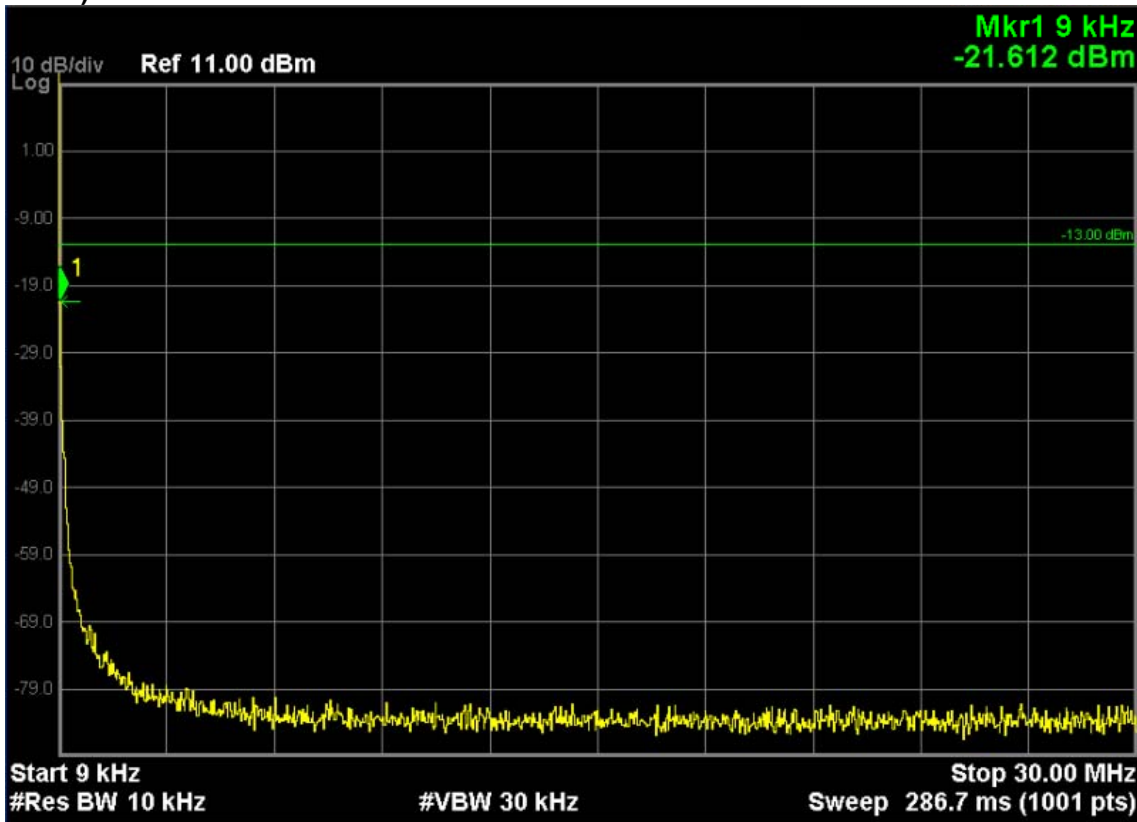

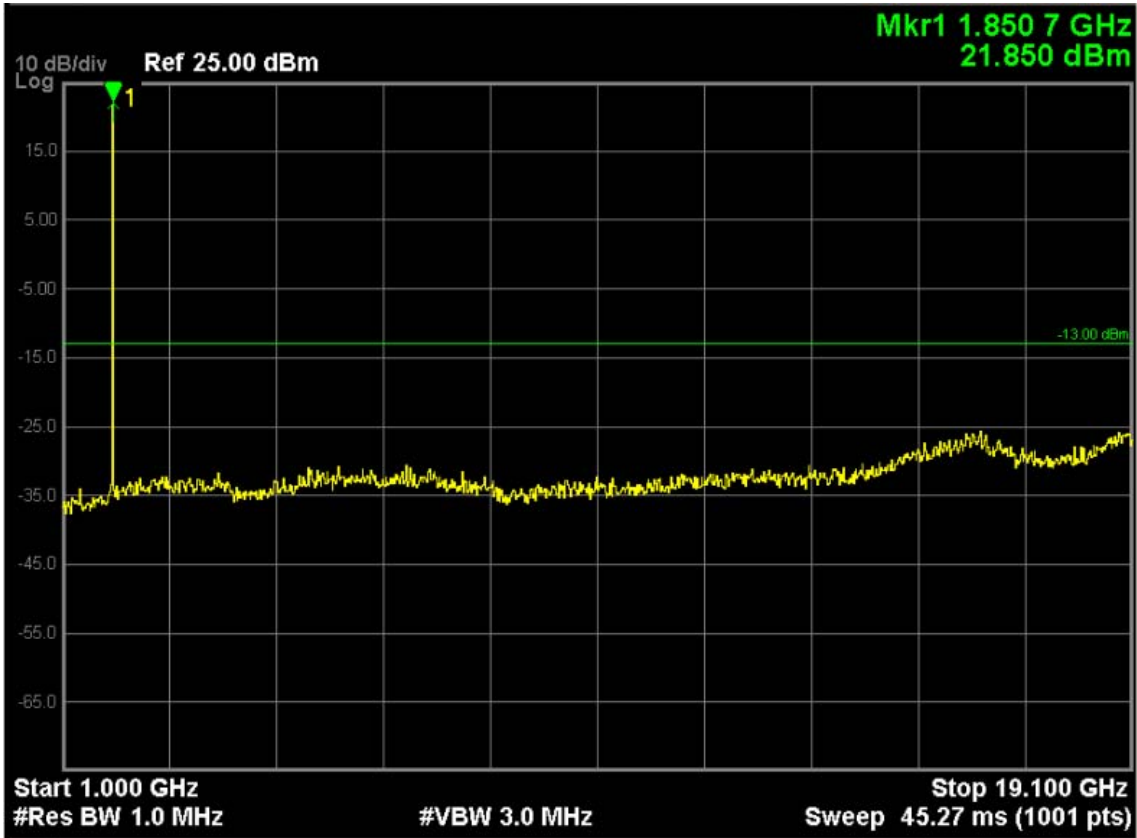

LTE Band 2 (16-QAM, Band Width 10MHz, RB Size 1, RB Offset 49, Channel 18900, Frequency 1880.0MHz)

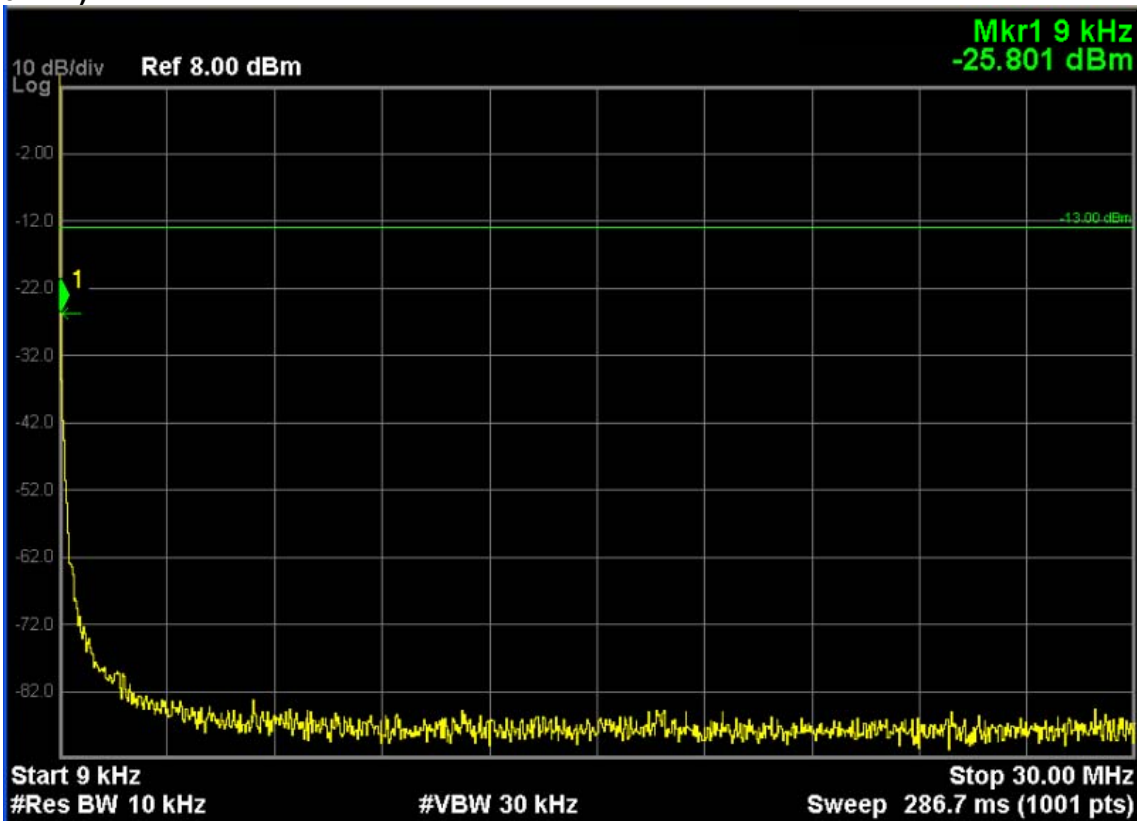

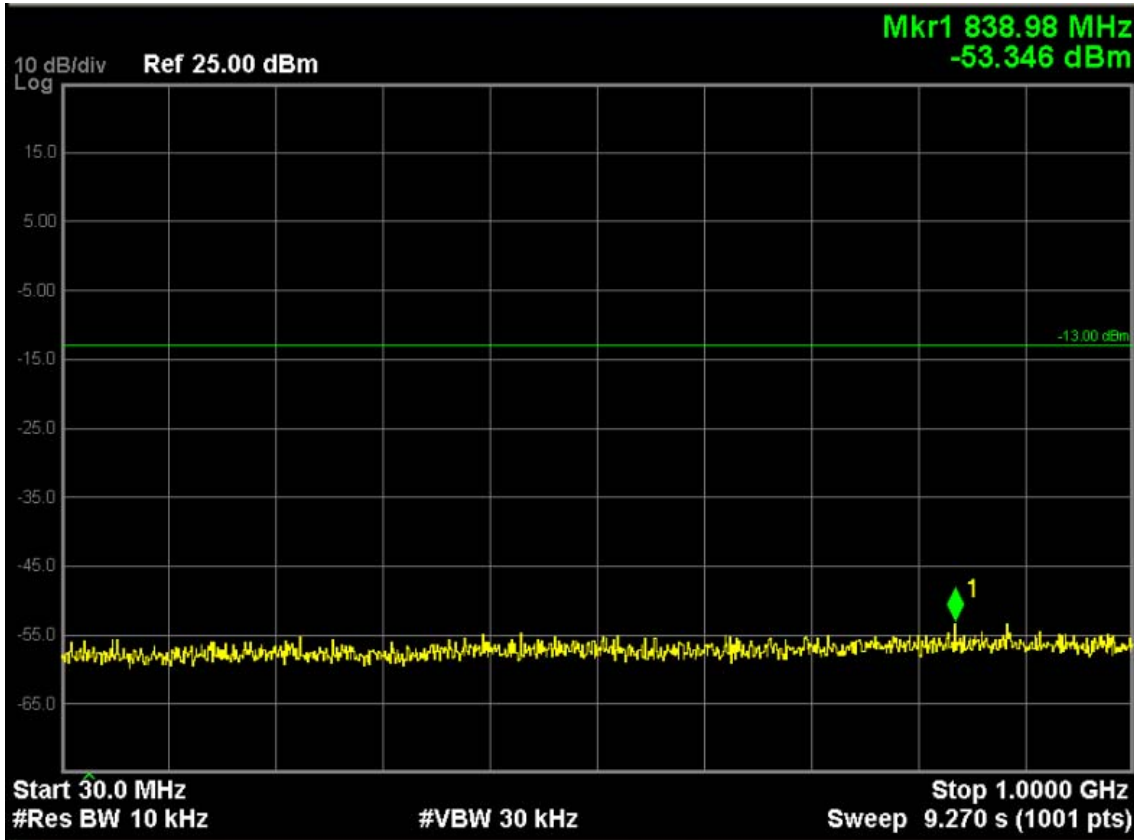

Note: The signal at point 1 is carrier

**LTE Band 2 (QPSK, Band Width 15MHz,RB Size 1,RB Offset 74,Channel 18675,Frequeeny 1857.5MHz)**

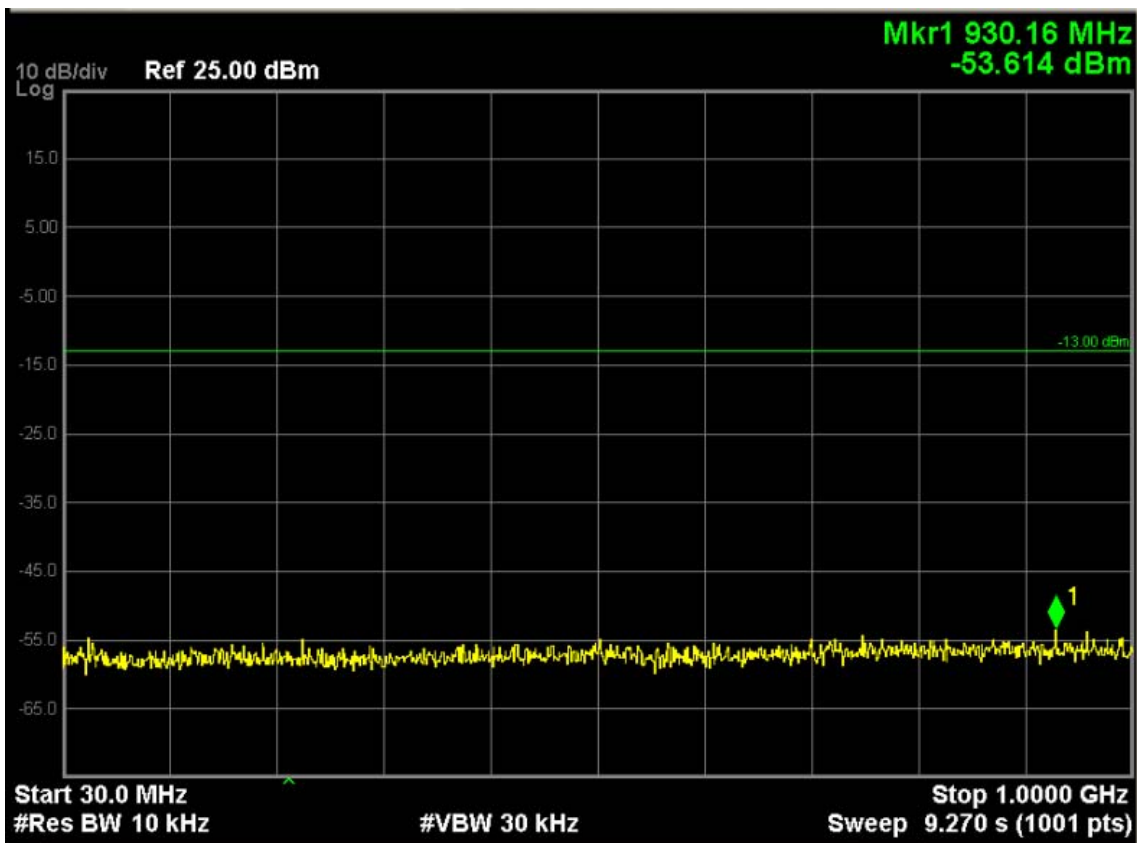
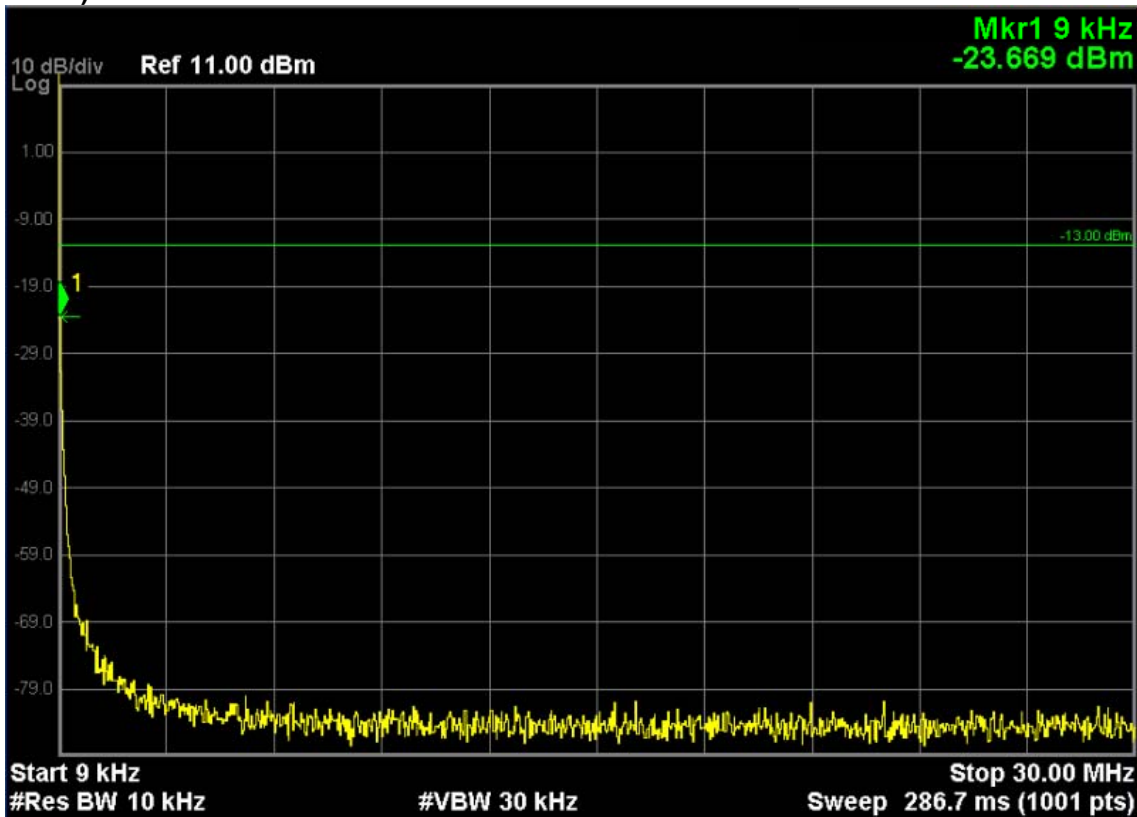



LTE Band 2 (16-QAM, Band Width 15MHz, RB Size 1, RB Offset 0, Channel 19125, Frequency 1902.5MHz)

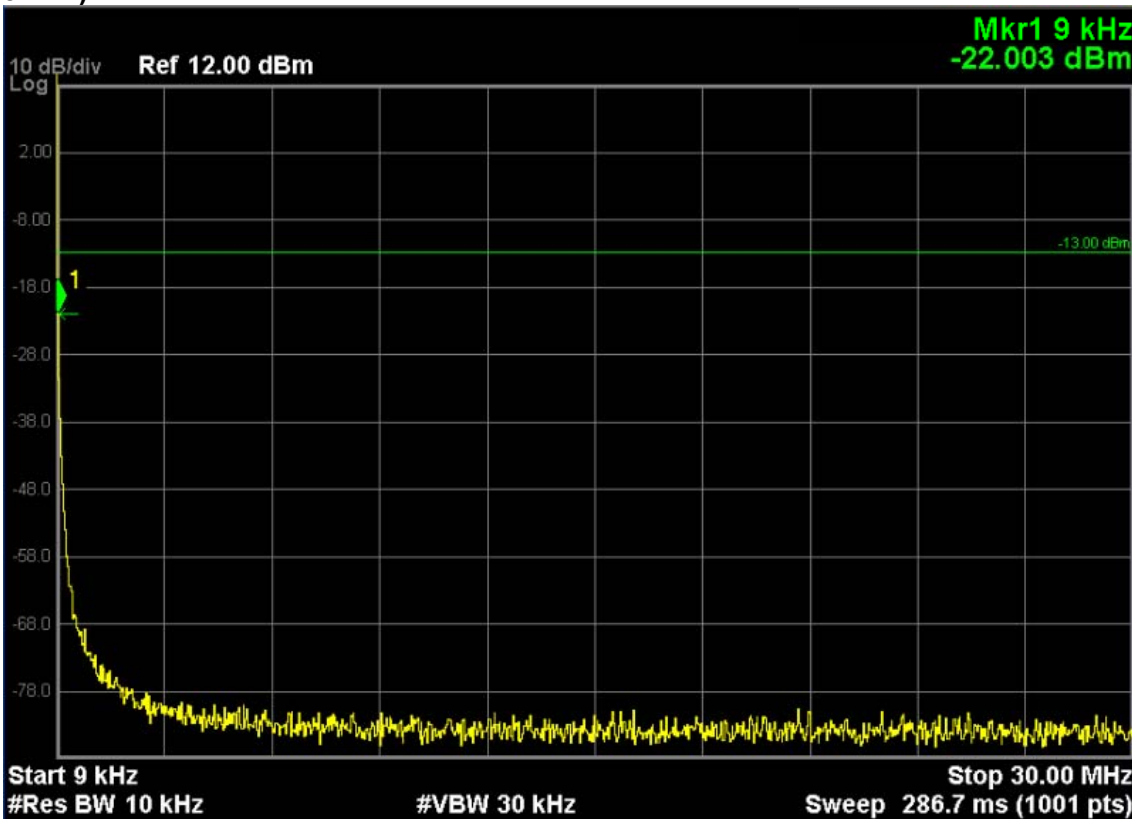

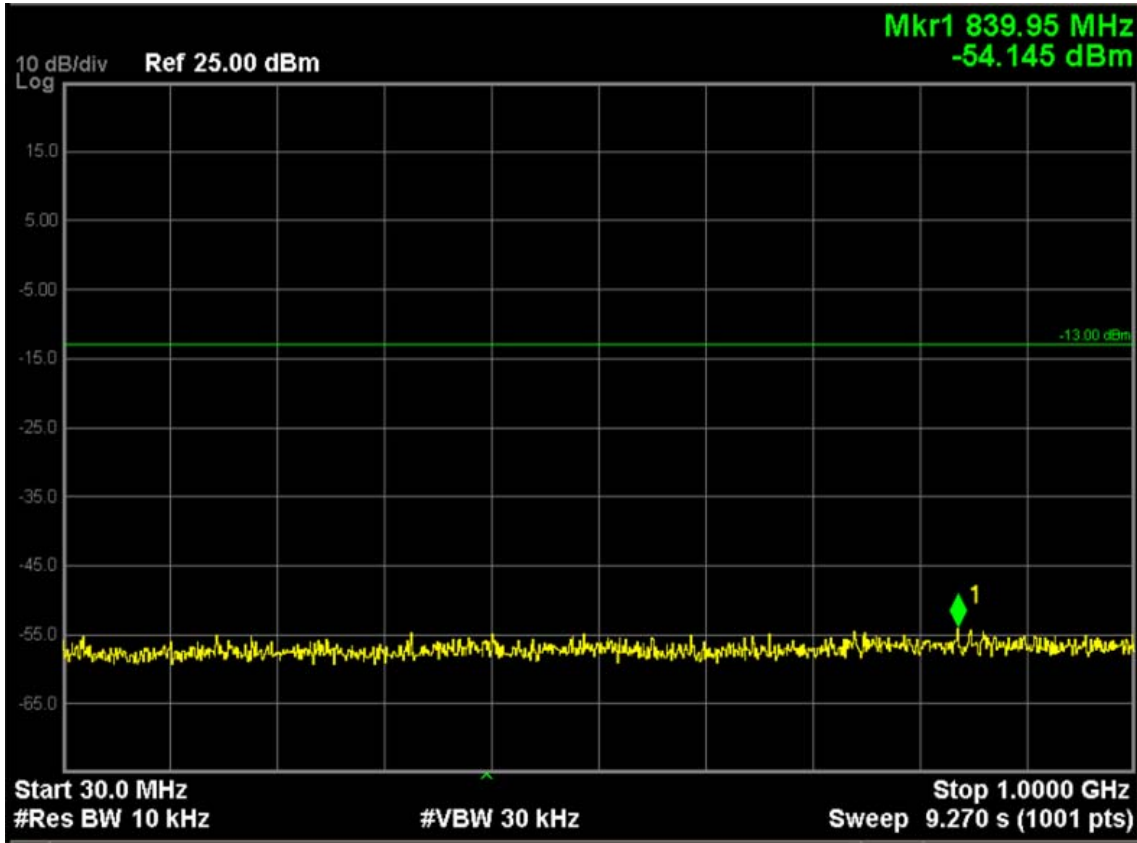

Note: The signal at point 1 is carrier



**LTE Band 2 (QPSK, Band Width 20MHz,RB Size 1,RB Offset 0,Channel 19100,Frequency 1900.0MHz)**

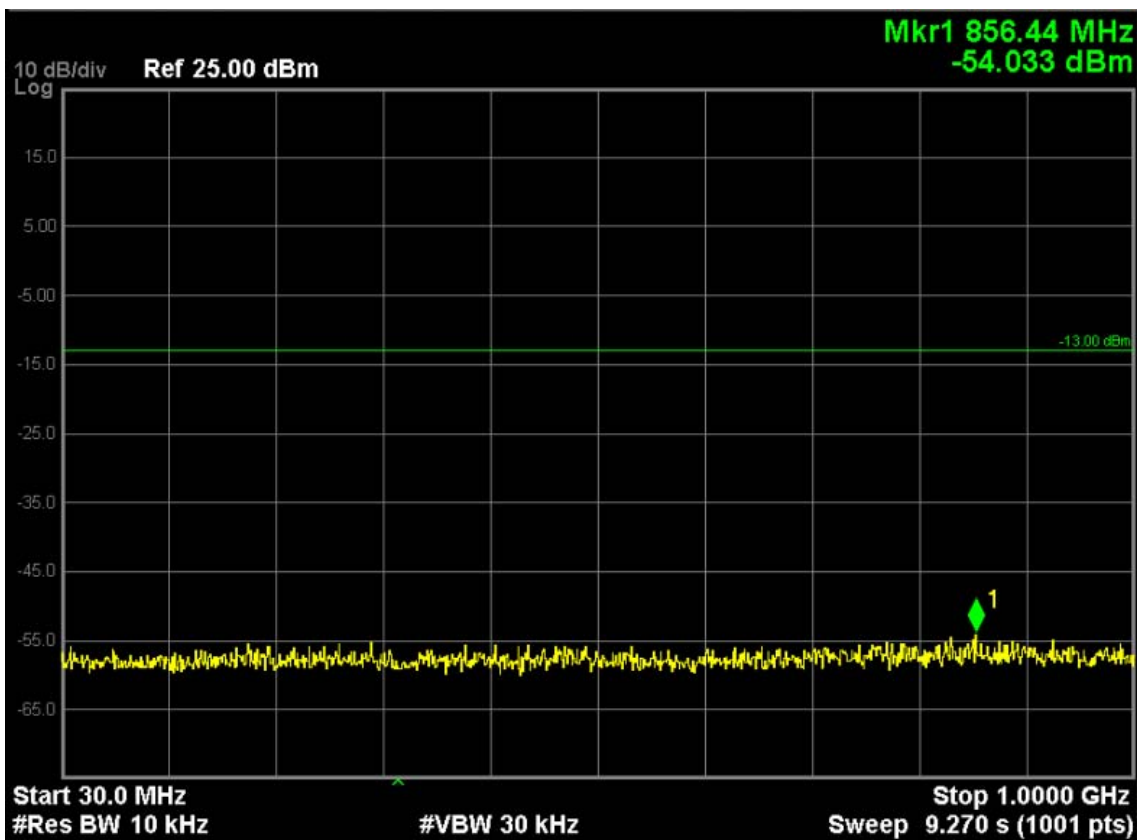
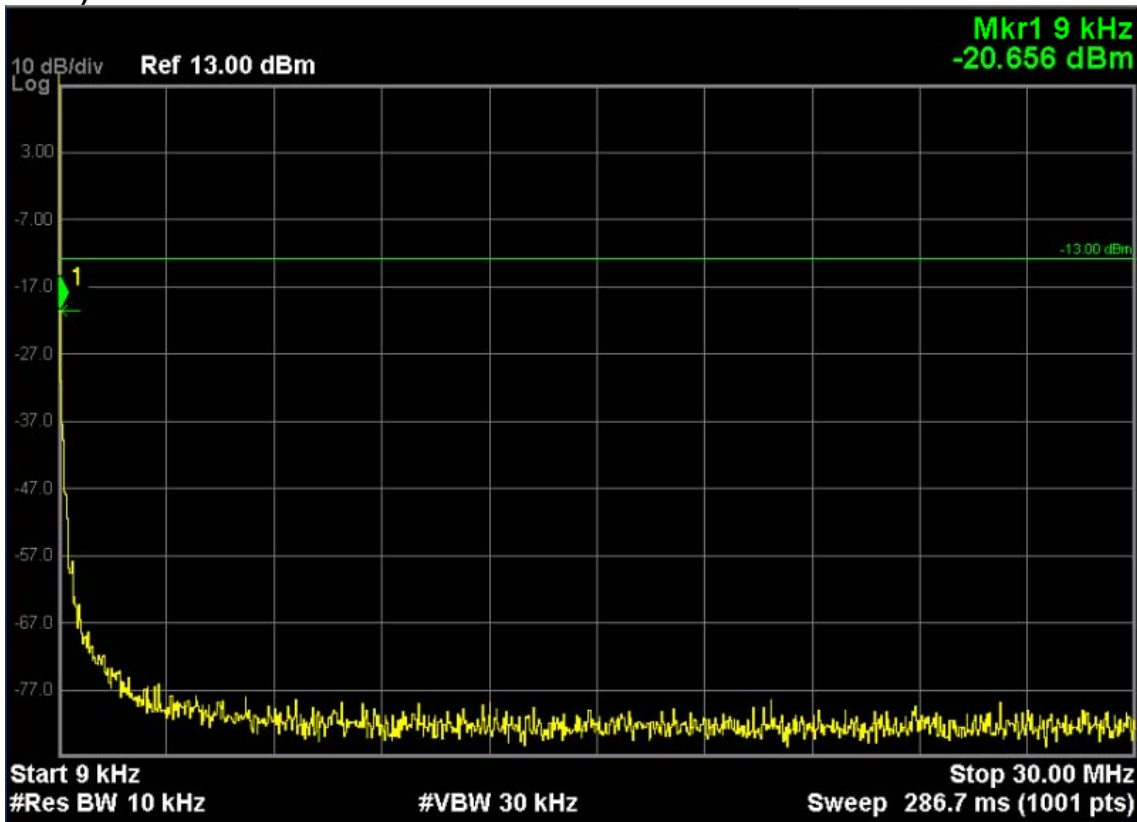

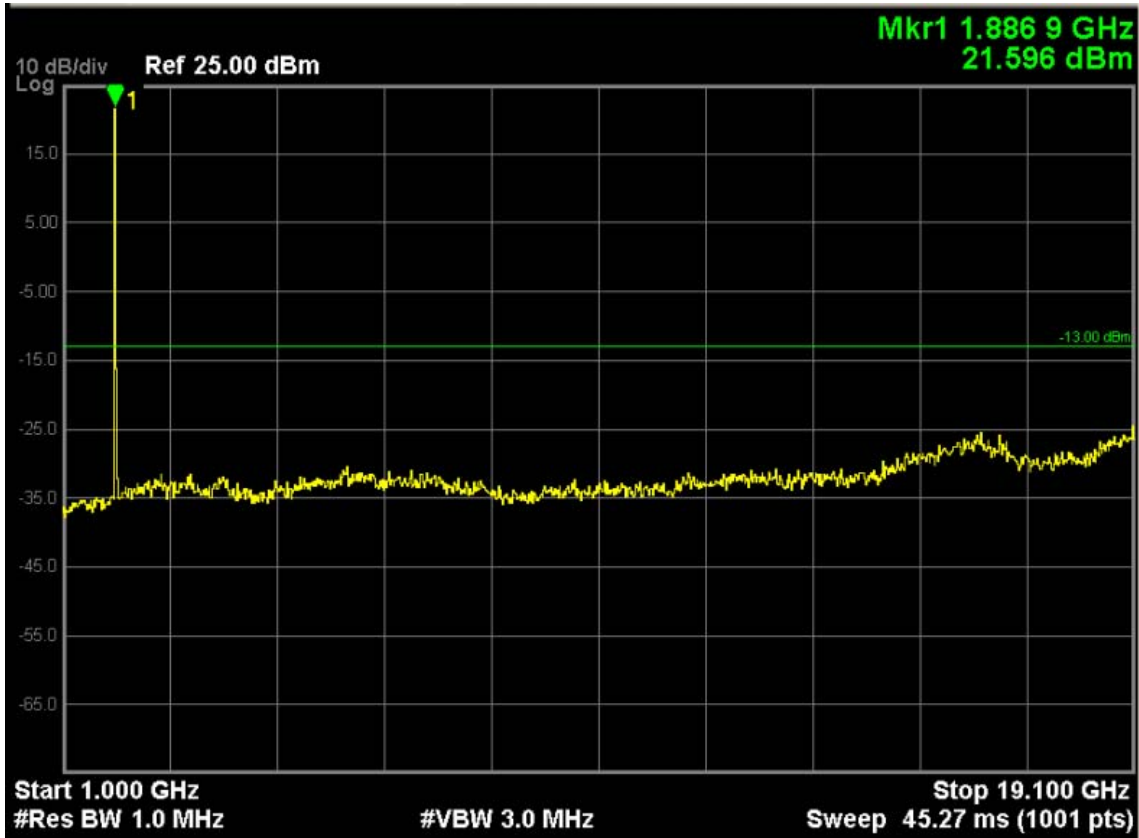

Note: The signal at point 1 is carrier

LTE Band 2 (16-QAM, Band Width 20MHz, RB Size 1, RB Offset 99, Channel 18900, Frequency 1880.0MHz)

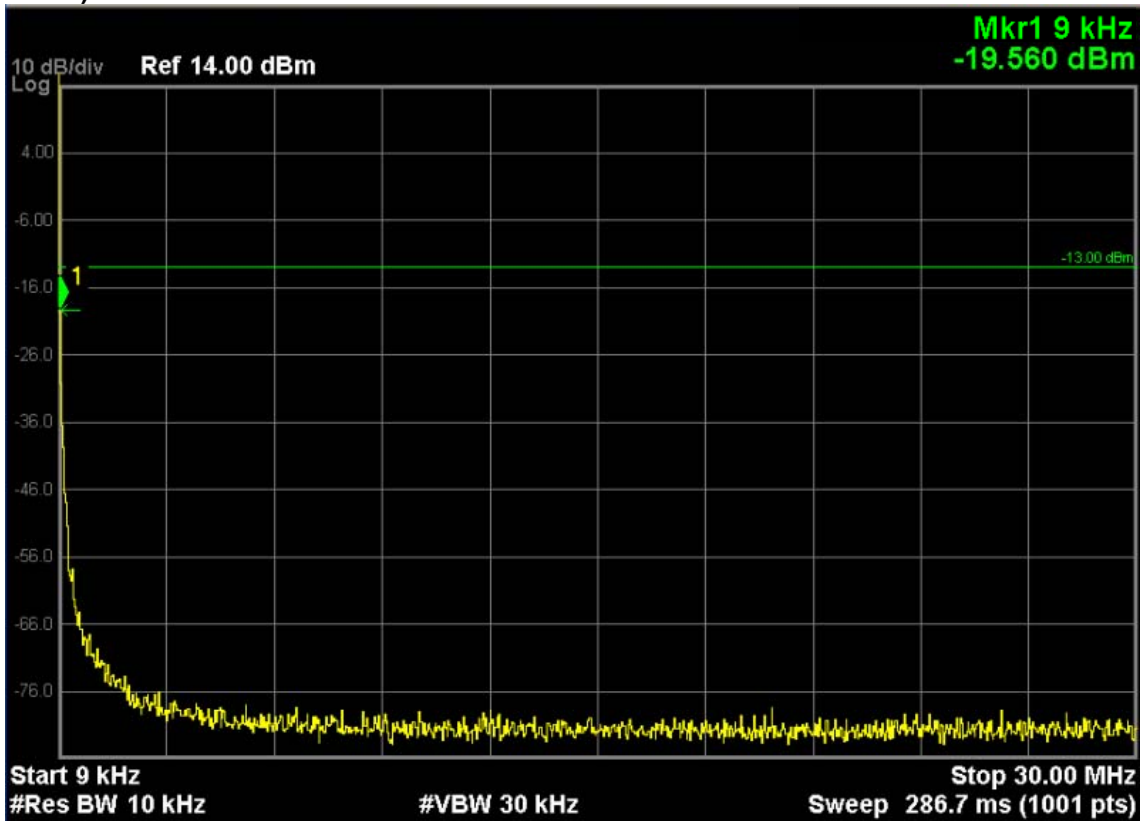

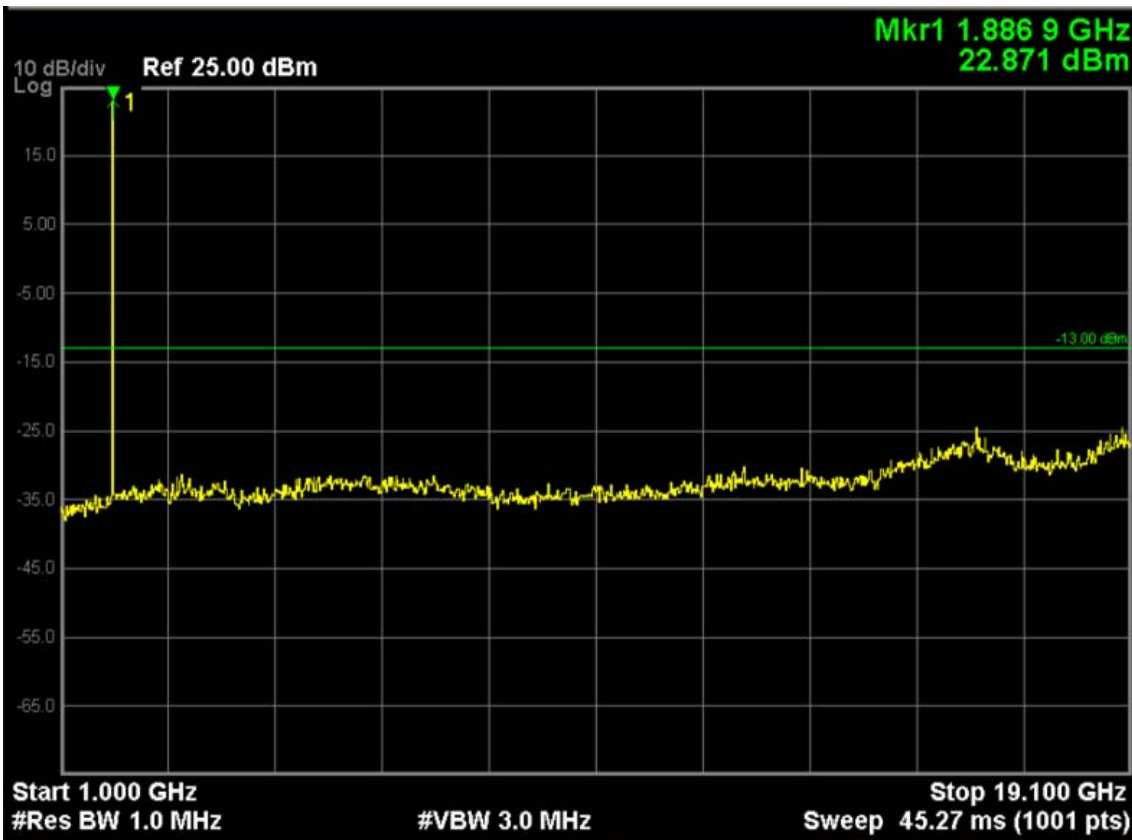
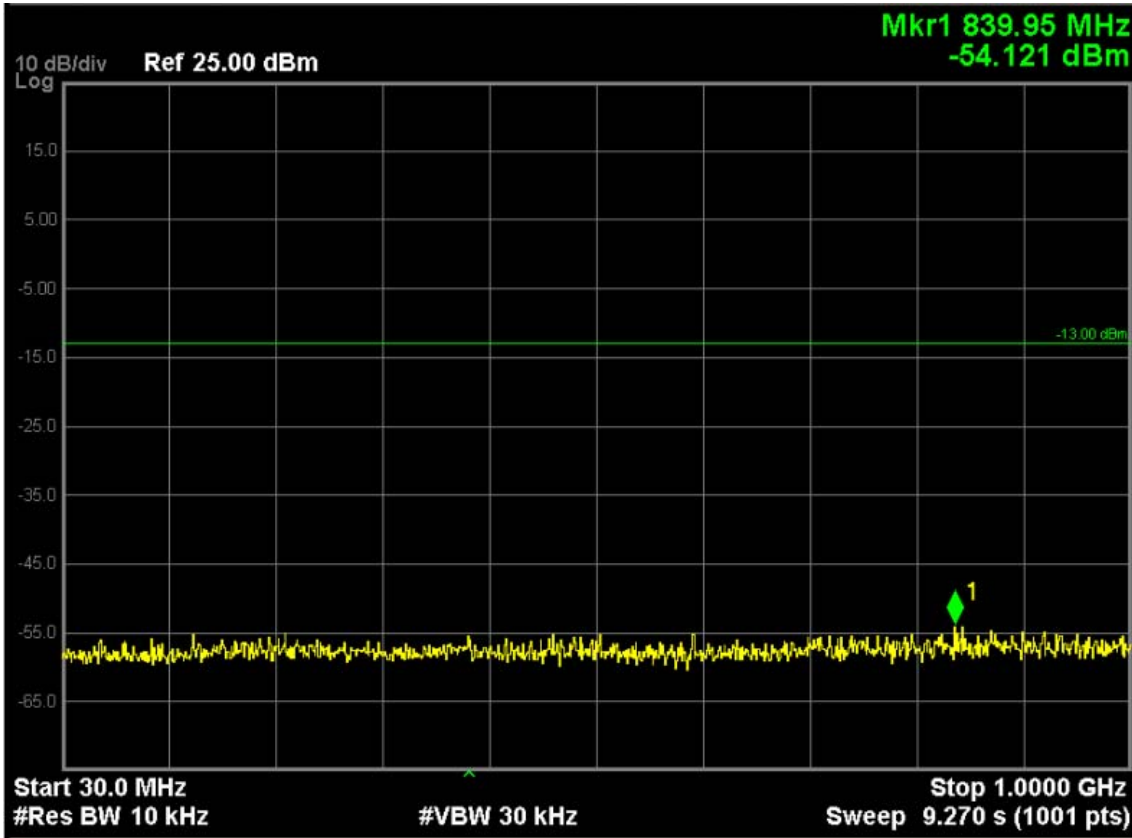

Note: The signal at point 1 is carrier

**LTE Band 4 (QPSK, Band Width 1.4MHz, RB Size 1, RB Offset 0, Channel 19957, Frequency 1710.7MHz)**

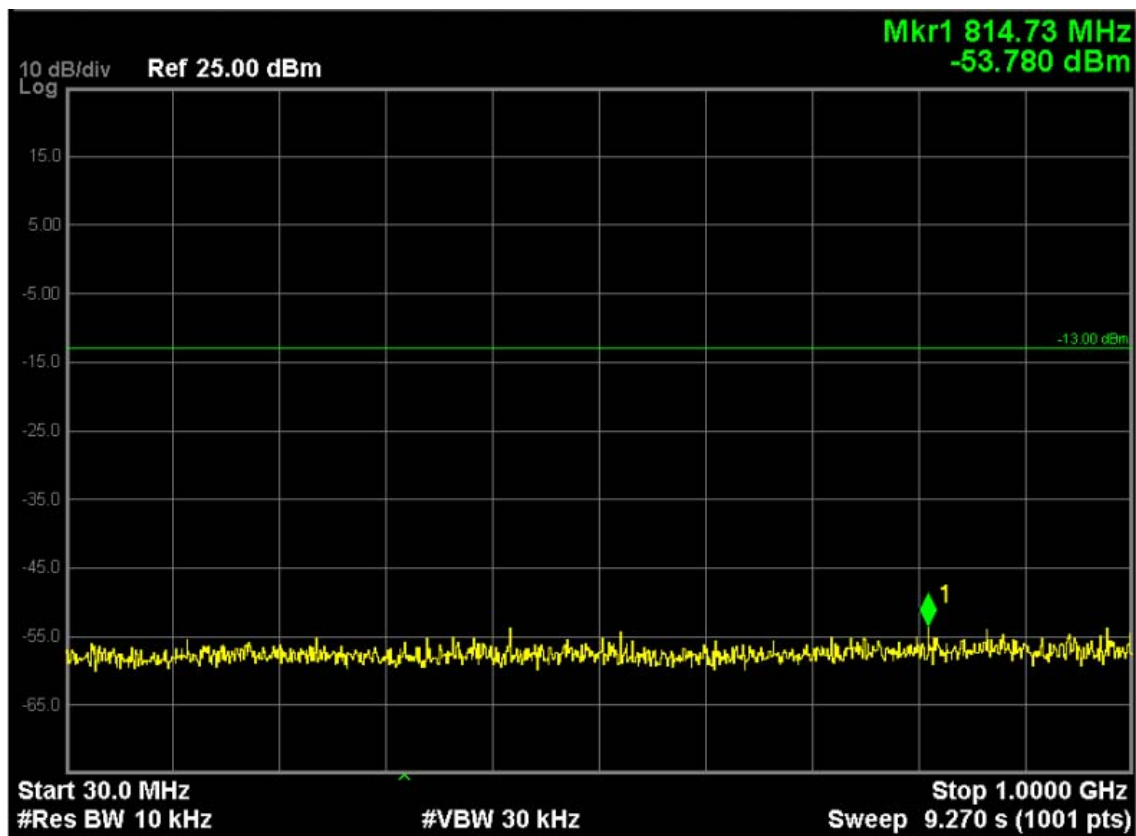
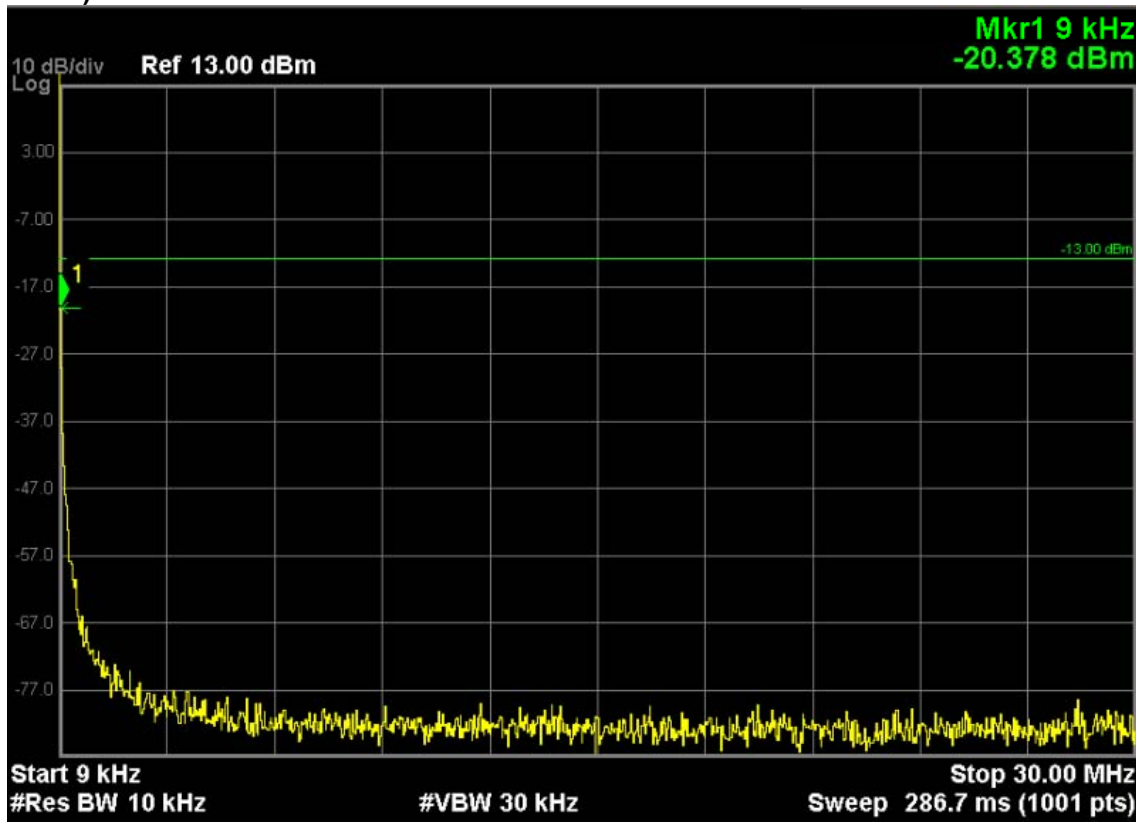

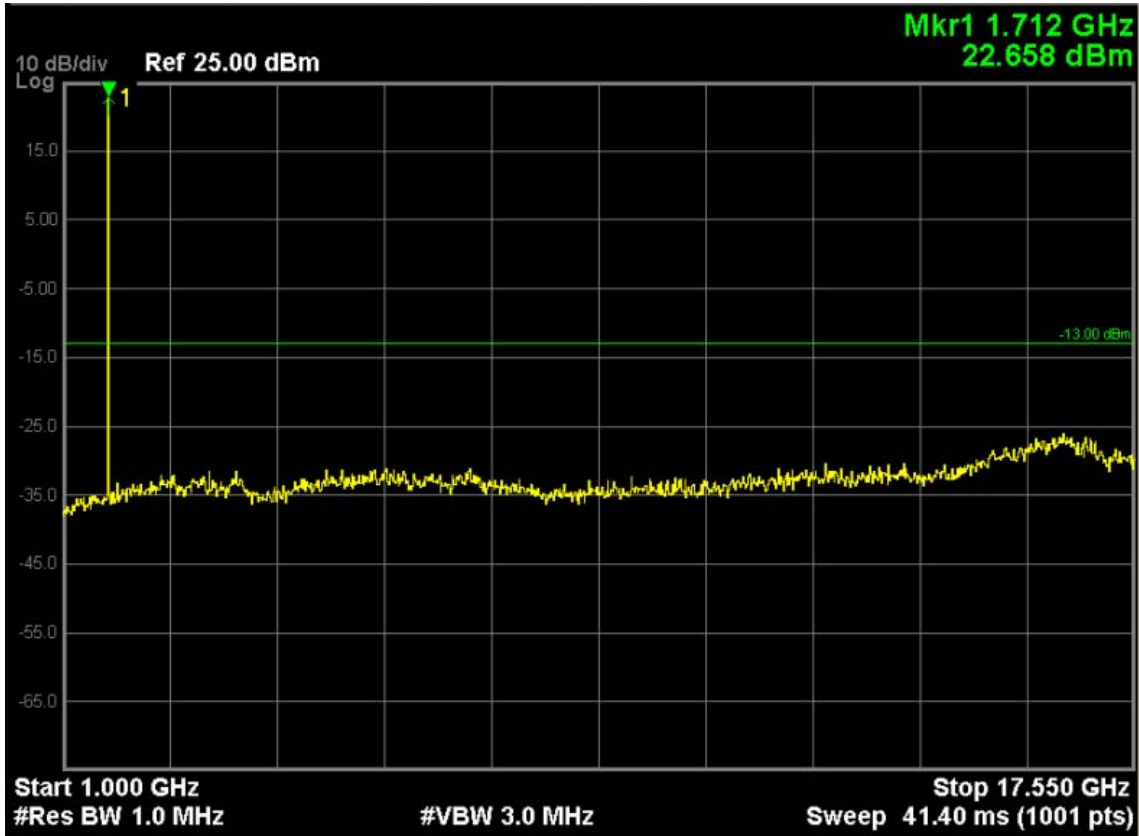

Note: The signal at point 1 is carrier

LTE Band 4 (16-QAM, Band Width 1.4MHz, RB Size 1, RB Offset 0, Channel 19957, Frequency 1710.7MHz)

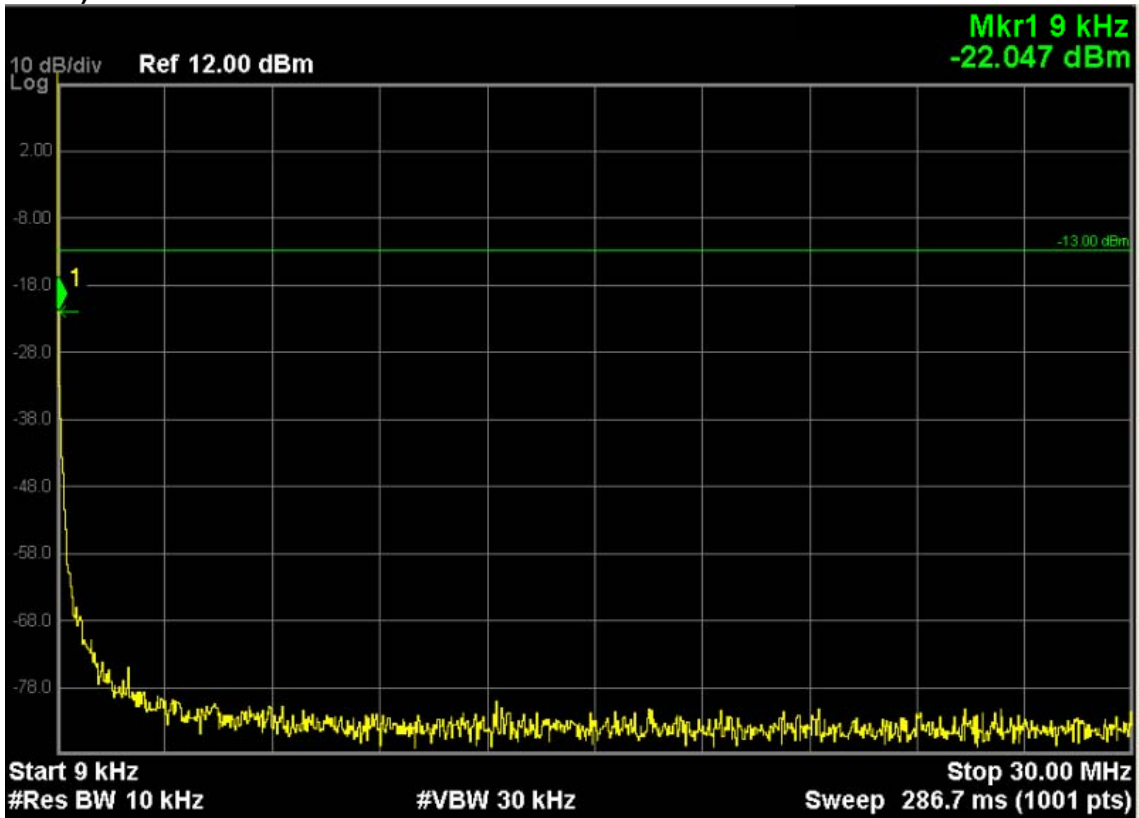

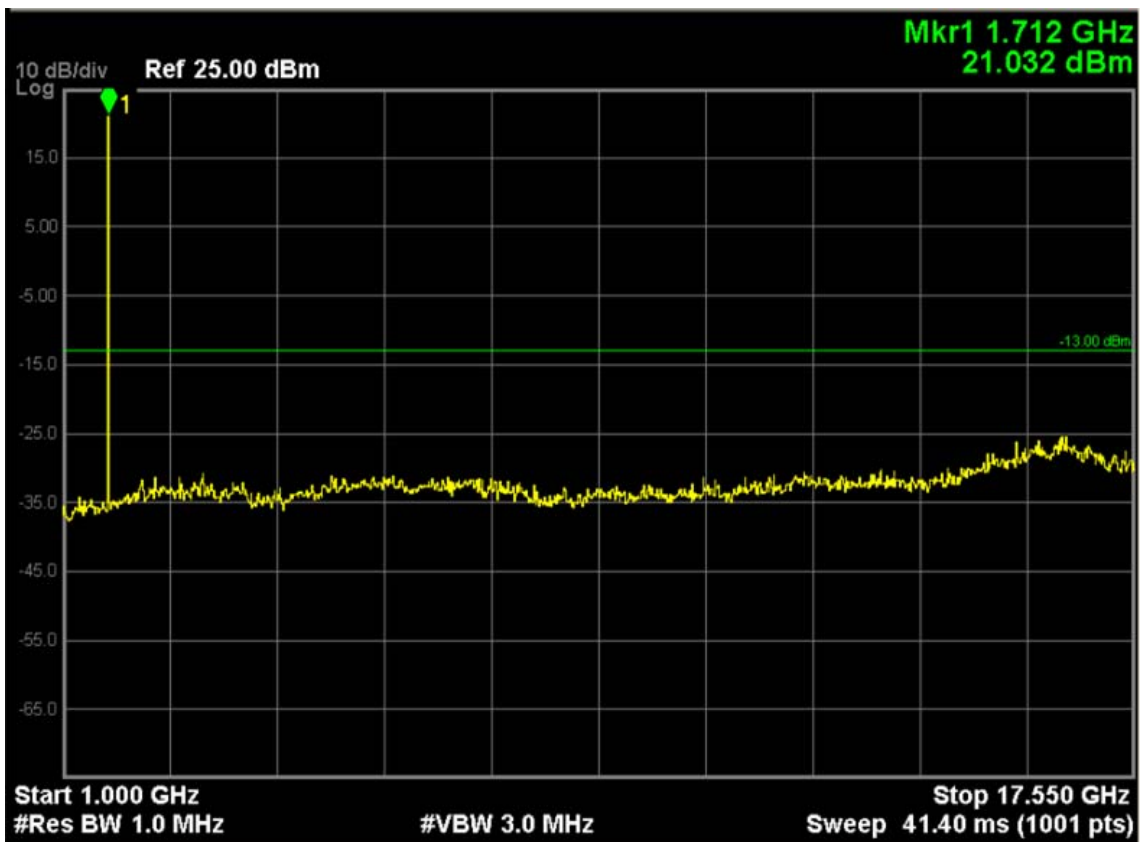
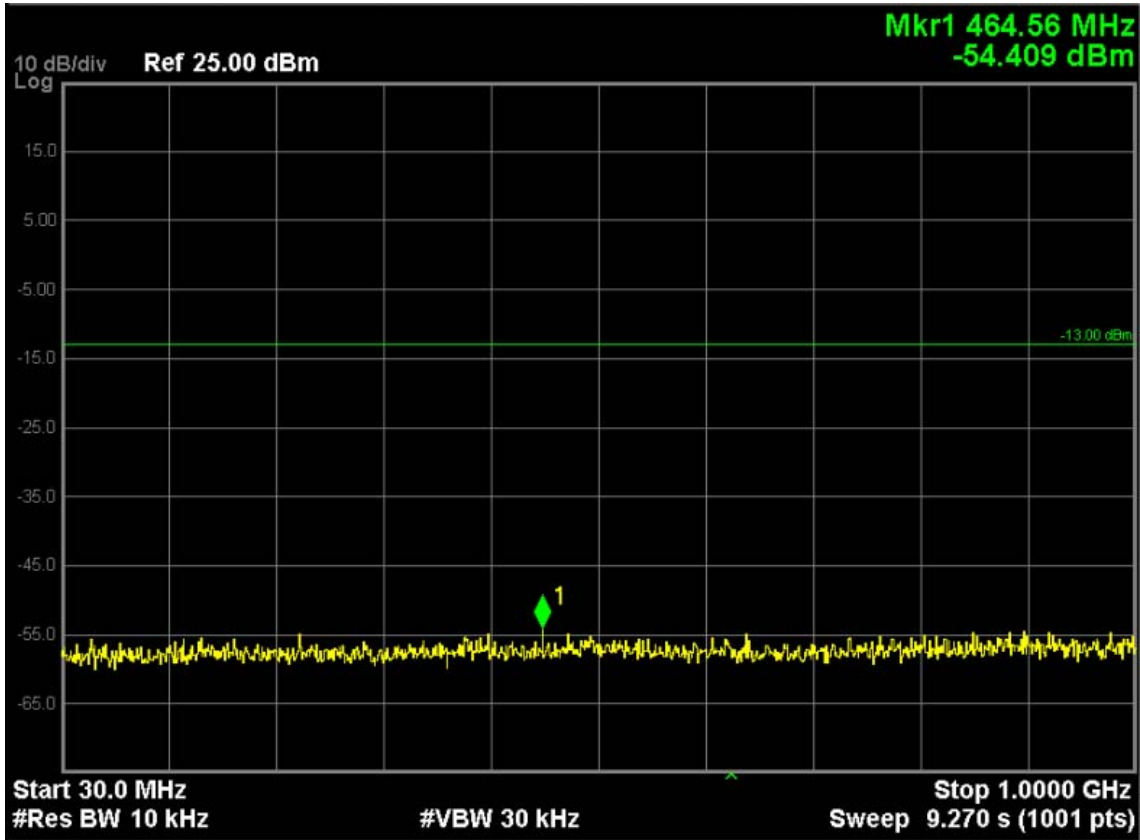

Note: The signal at point 1 is carrier

**LTE Band 4 (QPSK, Band Width 3MHz, RB Size 1, RB Offset 0, Channel 19965, Frequency 1711.5MHz)**

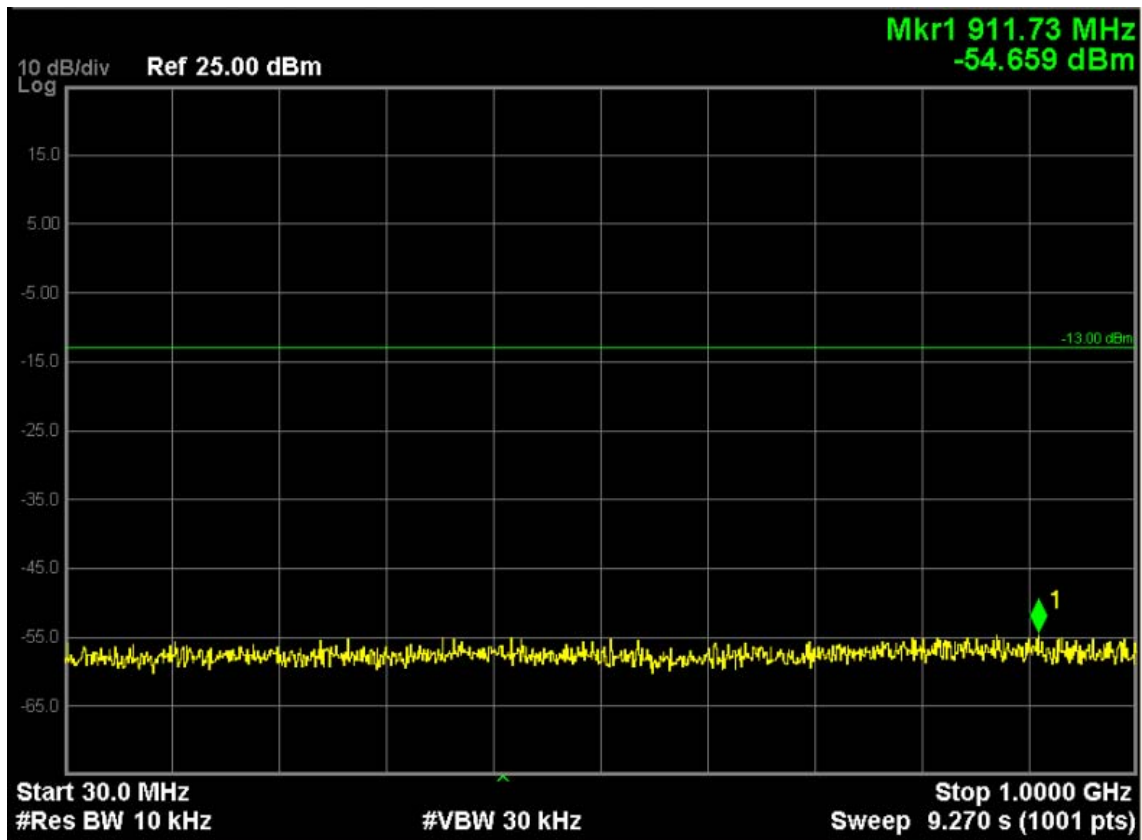
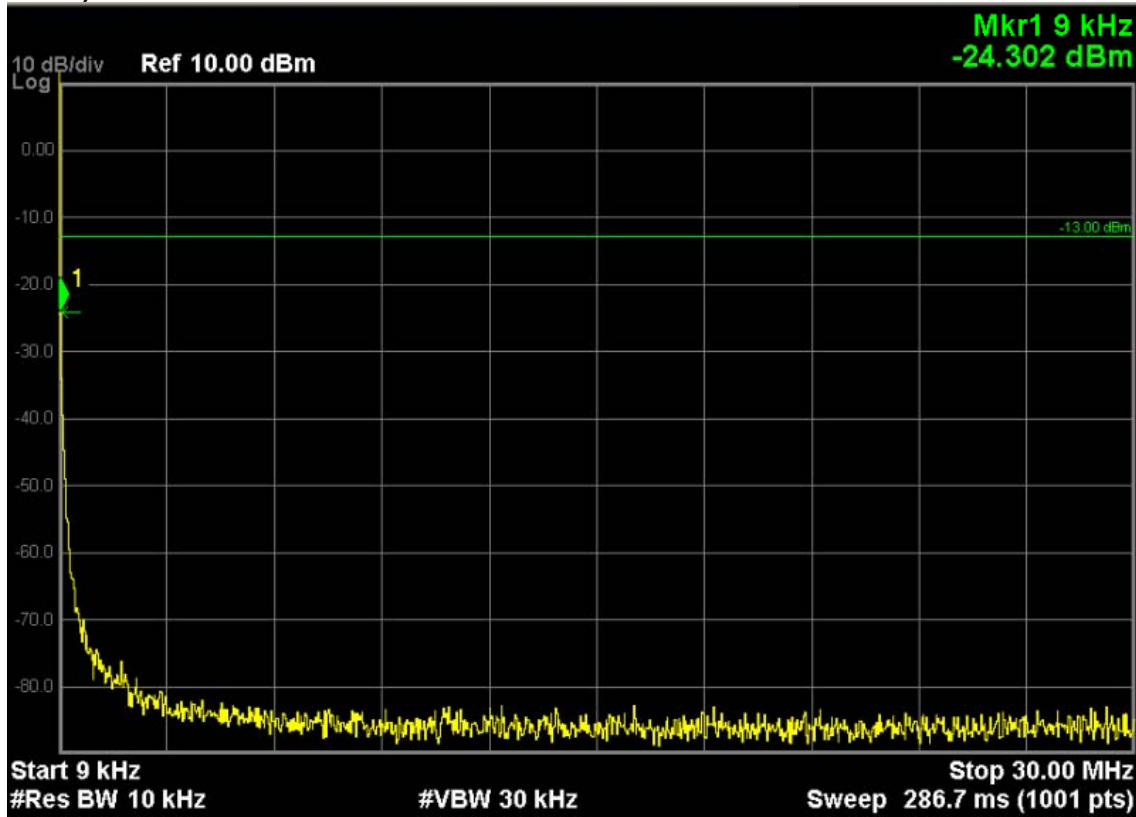

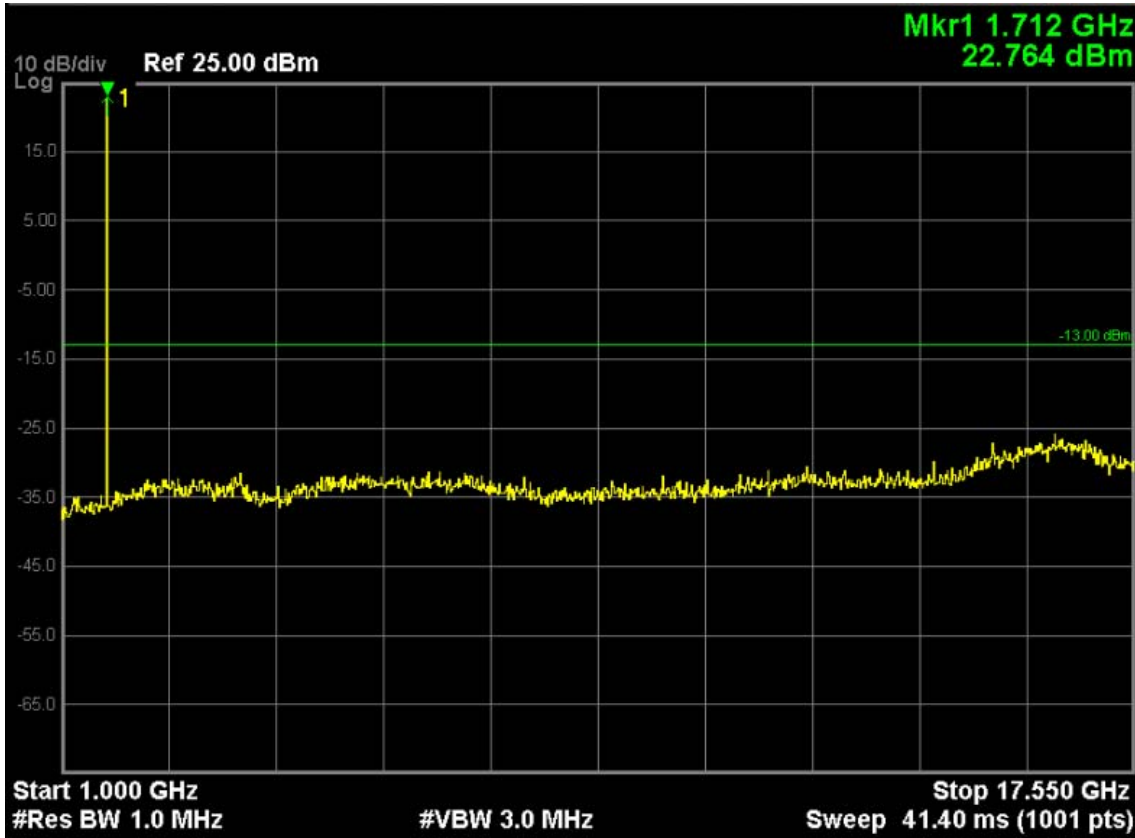

Note: The signal at point 1 is carrier

LTE Band 4 (16-QAM, Band Width 3MHz, RB Size 1, RB Offset 0, Channel 20385, Frequency 1753.5MHz)

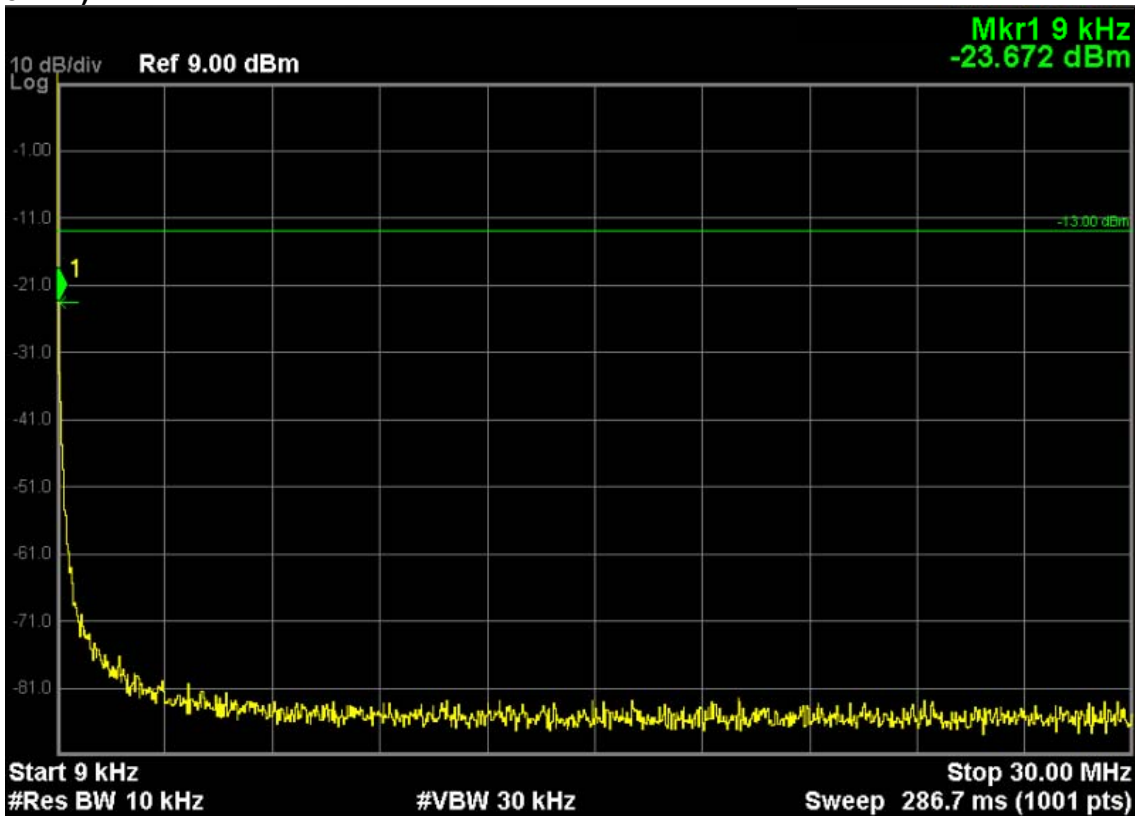



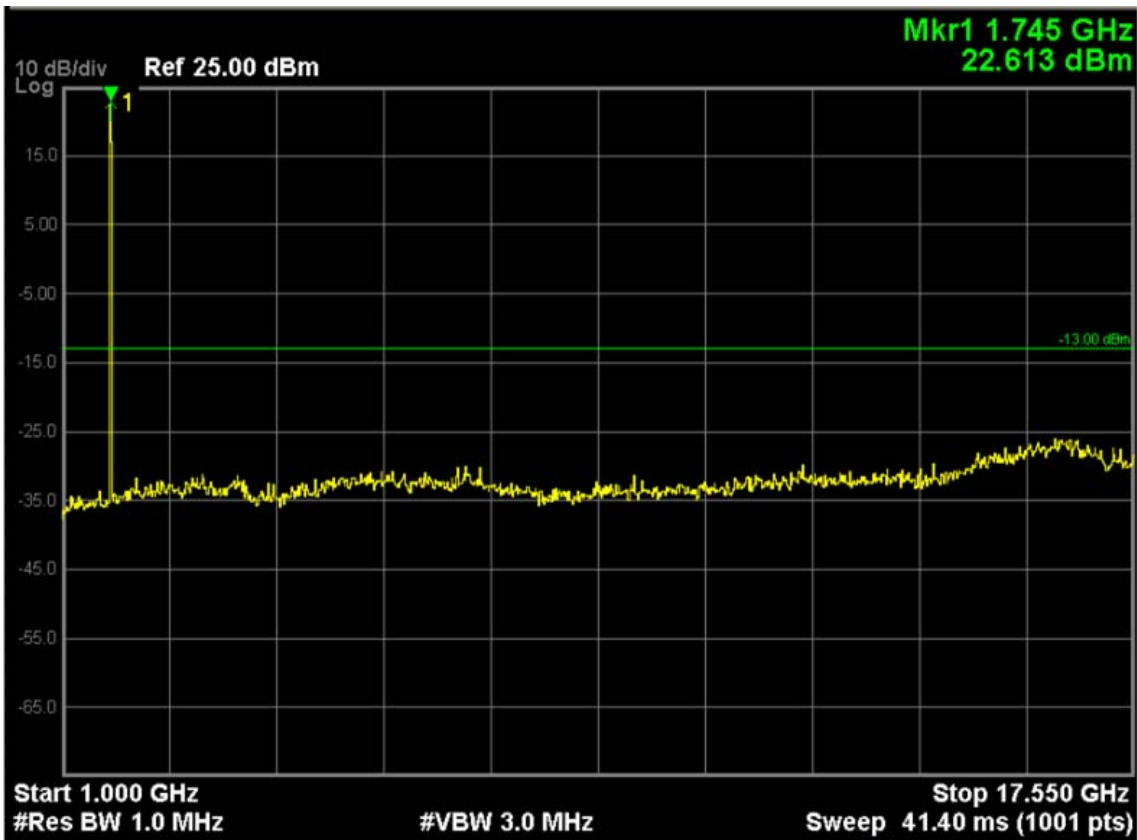
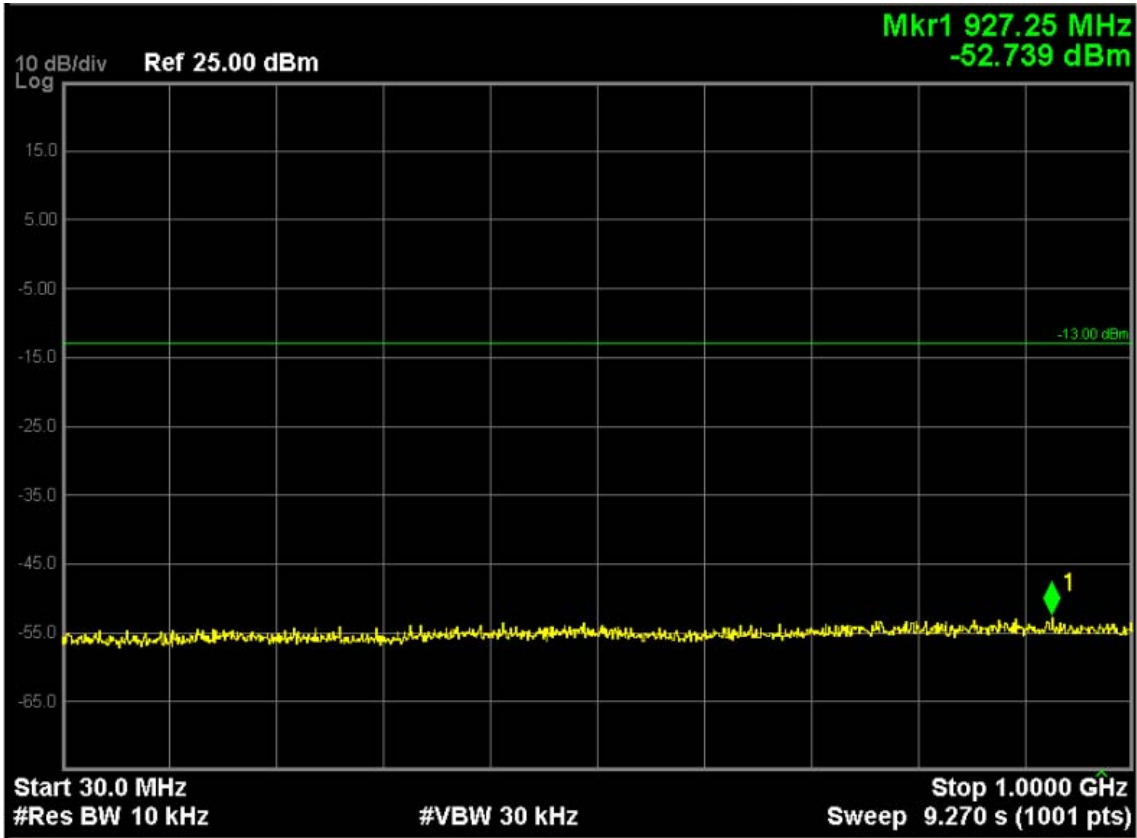

Note: The signal at point 1 is carrier

**LTE Band 4 (QPSK, Band Width 5MHz,RB Size 1,RB Offset 0,Channel 19975,Frequency 1712.5MHz)**

