

FCC Test Report

Product Name	Wireless Access Point
Model No	AP-90M
FCC ID	AFJ360300

Applicant	ICOM Incorporated
Address	1-1-32 Kamiminami, Hirano-ku, Osaka, 547-0003, Japan

Date of Receipt	Sep. 10, 2014
Issued Date	Feb. 04, 2015
Report No.	1490280R-RFUSP05V00
Report Version	V1.0



The test results relate only to the samples tested.
 The test results shown in the test report are traceable to the national/international standard through the calibration report of the equipment and evaluated measurement uncertainty herein.
 This report must not be used to claim product endorsement by TAF or any agency of the government.
 The test report shall not be reproduced without the written approval of QuieTek Corporation.

Test Report

Issued Date: Feb. 04, 2015

Report No.: 1490280R-RFUSP05V00



Product Name	Wireless Access Point
Applicant	ICOM Incorporated
Address	1-1-32 Kamiminami, Hirano-ku, Osaka, 547-0003, Japan
Manufacturer	ICOM Incorporated
Model No.	AP-90M
FCC ID.	AFJ360300
EUT Rated Voltage	AC 100-240V, 50-60Hz
EUT Test Voltage	AC 120V/60Hz
Trade Name	ICOM
Applicable Standard	FCC CFR Title 47 Part 15 Subpart E: 2013 ANSI C63.4: 2009, ANSI C63.10: 2009 FCC KDB 789033 D01 General UNII Test Procedures Old Rules v01r04
Test Result	Complied

Documented By :

(Senior Adm. Specialist / Joanne Lin)

Tested By :

(Engineer / Jack Hsu)

Approved By :

(Director / Vincent Lin)

TABLE OF CONTENTS

Description	Page
1. GENERAL INFORMATION.....	5
1.1. EUT Description.....	5
1.2. Operational Description	8
1.3. Tested System Details.....	9
1.4. Configuration of tested System	9
1.5. EUT Exercise Software	9
1.6. Test Facility	10
2. Conducted Emission	11
2.1. Test Equipment.....	11
2.2. Test Setup	11
2.3. Limits	12
2.4. Test Procedure	12
2.5. Uncertainty	12
2.6. Test Result of Conducted Emission.....	13
3. Maximun conducted output power.....	25
3.1. Test Equipment.....	25
3.2. Test Setup	25
3.3. Limits	26
3.4. Test Procedur.....	26
3.5. Uncertainty	27
3.6. Test Result of Maximum conducted output power.....	28
4. Peak Power Spectral Density	99
4.1. Test Equipment.....	99
4.2. Test Setup	99
4.3. Limits	99
4.4. Test Procedure	100
4.5. Uncertainty	100
4.6. Test Result of Peak Power Spectral Density	101
5. Peak Excursion.....	153
5.1. Test Equipment.....	153
5.2. Test Setup	153
5.3. Limits	153
5.4. Test Procedure	154
5.5. Uncertainty	154
5.6. Test Result of Peak Excursion.....	155
6. Radiated Emission.....	187

6.1.	Test Equipment.....	188
6.2.	Test Setup	189
6.3.	Limits	190
6.4.	Test Procedure	191
6.5.	Uncertainty	191
6.6.	Test Result of Radiated Emission.....	191
7.	Band Edge.....	265
7.1.	Test Equipment.....	265
7.2.	Test Setup	266
7.3.	Limits	267
7.4.	Test Procedure	267
7.5.	Uncertainty	267
7.6.	Test Result of Band Edge	268
8.	Frequency Stability	332
8.1.	Test Equipment.....	332
8.2.	Test Setup	332
8.3.	Limits	332
8.4.	Test Procedure	332
8.5.	Uncertainty	332
8.6.	Test Result of Frequency Stability.....	333
9.	EMI Reduction Method During Compliance Testing.....	349

Attachment 1: EUT Test Photographs

Attachment 2: EUT Detailed Photographs

1. GENERAL INFORMATION

1.1. EUT Description

Product Name	Wireless Access Point
Trade Name	ICOM
FCC ID.	AFJ360300
Model No.	AP-90M
Frequency Range	802.11a/n-20MHz: 5180-5320MHz, 5500-5700MHz 802.11n-40MHz: 5190-5310, 5510-5670MHz 802.11n-40MHz: 5190-5230, 5755-5795MHz 802.11ac-20MHz: 5720, 802.11ac-40MHz: 5710 MHz 802.11ac-80MHz: 5210-5290MHz, 5530-5690MHz
Number of Channels	802.11a/n-20MHz: 19; 802.11n-40MHz: 9 802.11ac-20MHz: 1, 802.11ac-40MHz: 1, 802.11ac-80MHz: 4
Data Rate	802.11a: 6 - 54Mbps 802.11n: up to 300Mbps 802.11ac-80MHz: up to 866.7MHz
Type of Modulation	802.11a/n:OFDM, BPSK, QPSK, 16QAM, 64QAM, 256QAM
Channel Control	Auto
Antenna type	Internal / External: Dipole
Antenna Gain	Refer to the table “Antenna List”
Power Adapter	MFR: ICOM, M/N: SA142B-12U Input: AC 100-240V~50-60Hz, 1.2A Output: 12V $\overline{=}$ 3.5A Cable Out: Non-Shielded, 1.8m

Antenna List

No.	Manufacturer	Part No.	Antenna Type	Peak Gain	Note
1	Wistron NeWeb Corp.	3ARNRA001S1 (Main)(Aux)	Dipole	2.73dBi for 5.15~5.25GHz 2.73dBi for 5.25~5.35GHz 3.24dBi for 5.47~5.725GHz 3.24dBi for 5.725~5.825GHz	Internal Antenna
2	WHA YU INDUSTRIAL	C1251-510008-A (Main)(Aux)	Dipole	5.00dBi for 5.15~5.25GHz 5.00dBi for 5.25~5.35GHz 5.00dBi for 5.47~5.725GHz 5.00dBi for 5.725~5.825GHz	External Antenna

Note: The antenna connector is Reverse SMA type.

Internal Antenna:

802.11a/n-20MHz Center Working Frequency of Each Channel:

Channel	Frequency	Channel	Frequency	Channel	Frequency	Channel	Frequency
Channel 36:	5180 MHz	Channel 40:	5200 MHz	Channel 44:	5220 MHz	Channel 48:	5240 MHz
Channel 52:	5260 MHz	Channel 56:	5280 MHz	Channel 60:	5300 MHz	Channel 64:	5320 MHz
Channel 100:	5500 MHz	Channel 104:	5520 MHz	Channel 108:	5540 MHz	Channel 112:	5560 MHz
Channel 116:	5580 MHz	Channel 132:	5660 MHz	Channel 136:	5680 MHz	Channel 140:	5700 MHz

802.11n-40MHz Center Working Frequency of Each Channel:

Channel	Frequency	Channel	Frequency
Channel 38:	5190 MHz	Channel 46:	5230 MHz

External Antenna:

802.11a/n-20MHz Center Working Frequency of Each Channel:

Channel	Frequency	Channel	Frequency	Channel	Frequency	Channel	Frequency
Channel 36:	5180 MHz	Channel 40:	5200 MHz	Channel 44:	5220 MHz	Channel 48:	5240 MHz
Channel 52:	5260 MHz	Channel 56:	5280 MHz	Channel 60:	5300 MHz	Channel 64:	5320 MHz
Channel 100:	5500 MHz	Channel 104:	5520 MHz	Channel 108:	5540 MHz	Channel 112:	5560 MHz
Channel 116:	5580 MHz	Channel 132:	5660 MHz	Channel 136:	5680 MHz	Channel 140:	5700 MHz

802.11n-40MHz Center Working Frequency of Each Channel:

Channel	Frequency	Channel	Frequency	Channel	Frequency	Channel	Frequency
Channel 38:	5190 MHz	Channel 46:	5230 MHz	Channel 54:	5270 MHz	Channel 62:	5310 MHz
Channel 102:	5510 MHz	Channel 110:	5550 MHz	Channel 134:	5670 MHz		

802.11ac-20MHz Center Working Frequency of Each Channel:

Channel	Frequency
Channel 144:	5720 MHz

802.11ac-40MHz Center Working Frequency of Each Channel:

Channel	Frequency
Channel 142:	5710 MHz

802.11ac-80MHz Center Working Frequency of Each Channel:

Channel	Frequency	Channel	Frequency	Channel	Frequency	Channel	Frequency
Channel 42:	5210 MHz	Channel 58:	5290 MHz	Channel 106:	5530 MHz	Channel 138:	5690 MHz

Note:

1. This device is a Wireless Access Point with a built-in two WLAN transceivers, Internal Antenna of transceiver support 802.11a/n20/n40, External Antenna of transceiver support 802.11a/n20/n40/ac20/ac40/ac80 technology.
2. Regarding to the operation frequency, the lowest, middle and highest frequency are selected to perform the test.
3. Continuous transmission mode provides a 100% duty cycle to perform the test.
4. At result of pretests, module supports dual-channel transmission, only the worst case is shown in the report. (802.11a is chain A)
5. Lowest and highest data rates are tested in each mode. Only worst case is shown in the report. (802.11a is 6Mbps 、 802.11n-20BW is 14.4Mbps 、 802.11n-40BW is 30Mbps and 802.11ac(80M-BW) is 65 Mbps)
6. These tests were conducted on a sample of the equipment for the purpose of demonstrating compliance with Part 15 Subpart E for Unlicensed National Information Infrastructure devices.
7. The EUT was setup according to ANSI C63.10: 2009 (table height of 1.5 meters was used during radiated emission measurements above 1 GHz instead of a 80 cm table height).

Test Mode	Mode 1: Transmit (802.11a-6Mbps) Mode 2: Transmit (802.11n-20BW 14.4Mbps) Mode 3: Transmit (802.11n-40BW 30Mbps) Mode 4: Transmit (802.11ac-20BW-7.2Mbps) Mode 5: Transmit (802.11ac-40BW-15Mbps) Mode 6: Transmit (802.11ac-80BW-65Mbps)
-----------	--

1.3. Tested System Details

The types for all equipment, plus descriptions of all cables used in the tested system (including inserted cards) are:

Product	Manufacturer	Model No.	Serial No.	Power Cord
1 Notebook PC	DELL	PP18L	36119001664	Non-Shielded, 0.8m
2 FLASH	Transcend	JetFlash110	155422-2931	N/A

Signal Cable Type	Signal cable Description
A LAN Cable	Non-Shielded, 2m

1.4. Configuration of tested System

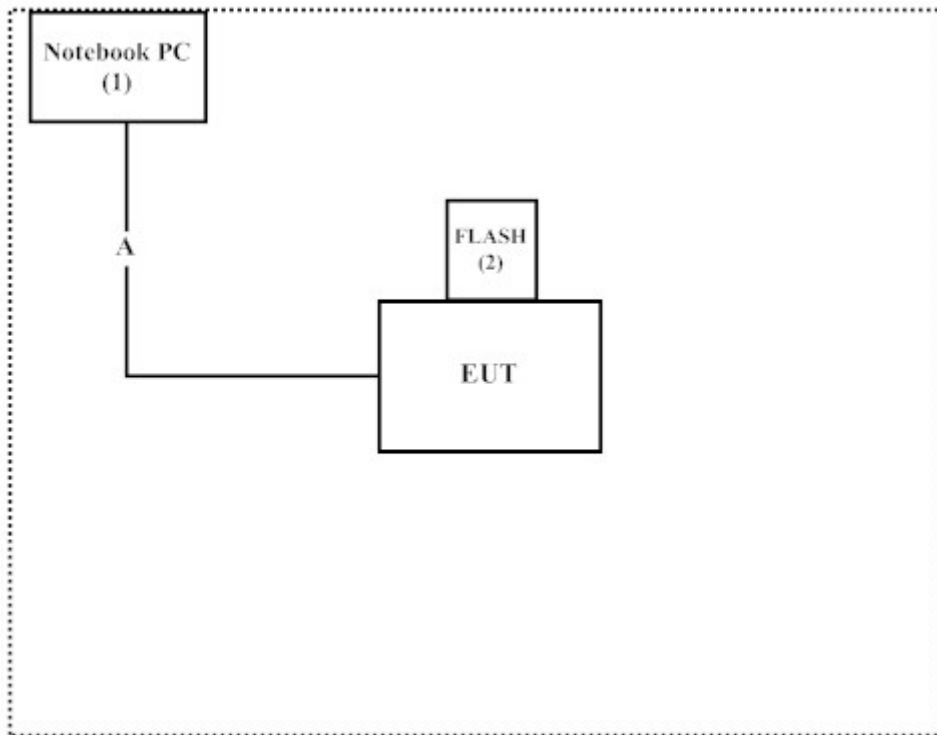

1.5. EUT Exercise Software

- (1) Setup the EUT as shown on 1.4
- (2) Execute “Cmd Tool v1.0.0.3” program on the EUT.
- (3) Configure the test mode, the test channel, and the data rate.
- (4) Start the continuous transmission.
- (5) Verify that the EUT works properly.

1.6. Test Facility

Ambient conditions in the laboratory:

Items	Required (IEC 68-1)	Actual
Temperature (°C)	15-35	20-35
Humidity (%RH)	25-75	50-65
Barometric pressure (mbar)	860-1060	950-1000

The related certificate for our laboratories about the test site and management system can be downloaded from Quietek Corporation's Web Site : <http://tw.quietek.com/modules/myalbum/>

The address and introduction of Quietek Corporation's laboratories can be founded in our Web site : <http://www.quietek.com/>

Site Description: File on
 Federal Communications Commission
 FCC Engineering Laboratory
 7435 Oakland Mills Road
 Columbia, MD 21046
 Registration Number: 92195

Site Name: Quietek Corporation
 Site Address: No.5-22, Ruishukeng Linkou Dist.,
 New Taipei City 24451, Taiwan, R.O.C.
 TEL: 886-2-8601-3788 / FAX : 886-2-8601-3789
 E-Mail : service@quietek.com

FCC Accreditation Number: TW1014

2. Conducted Emission

2.1. Test Equipment

	Equipment	Manufacturer	Model No. / Serial No.	Last Cal.	Remark
X	Test Receiver	R & S	ESCS 30 / 825442/018	Sep., 2014	
X	Artificial Mains Network	R & S	ENV4200 / 848411/10	Feb., 2015	Peripherals
X	LISN	R & S	ESH3-Z5 / 825562/002	Feb., 2015	EUT
	DC LISN	Schwarzbeck	8226 / 176	Mar., 2014	EUT
X	Pulse Limiter	R & S	ESH3-Z2 / 357.8810.52	Feb., 2015	
	No.1 Shielded Room				

Note:

1. All equipments are calibrated every one year.
2. The test instruments marked by “X” are used to measure the final test results.

2.2. Test Setup

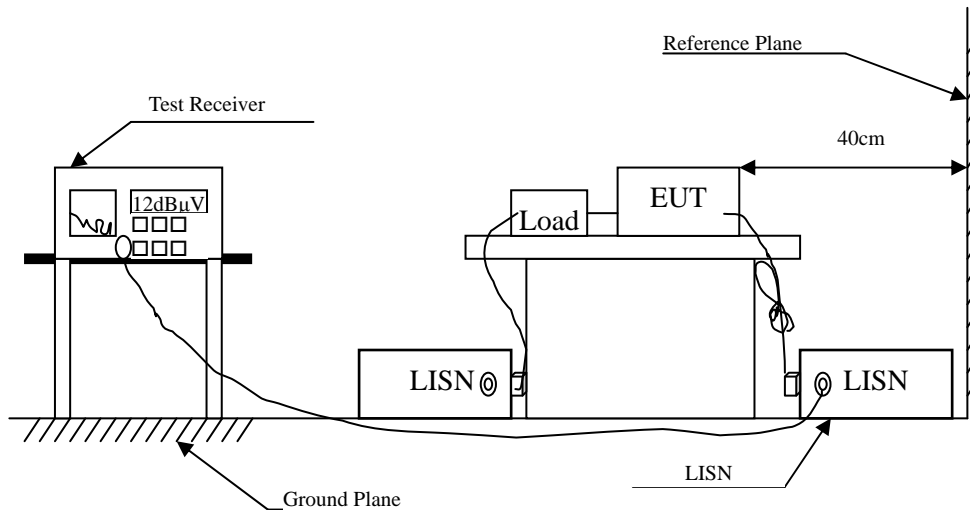

2.3. Limits

FCC Part 15 Subpart C Paragraph 15.207 (dBμV) Limit		
Frequency MHz	Limits	
	QP	AV
0.15 - 0.50	66-56	56-46
0.50-5.0	56	46
5.0 - 30	60	50

Remarks : In the above table, the tighter limit applies at the band edges.

2.4. Test Procedure

The EUT and simulators are connected to the main power through a line impedance stabilization network (L.I.S.N.). This provides a 50 ohm /50uH coupling impedance for the measuring equipment. The peripheral devices are also connected to the main power through a LISN that provides a 50ohm /50uH coupling impedance with 50ohm termination. (Please refers to the block diagram of the test setup and photographs.)

Both sides of A.C. line are checked for maximum conducted interference. In order to find the maximum emission, the relative positions of equipment and all of the interface cables must be changed according to ANSI C63.10: 2009 on conducted measurement.

Conducted emissions were invested over the frequency range from 0.15MHz to 30MHz using a receiver bandwidth of 9kHz.

The EUT was setup to ANSI C63.10: 2009; tested to UNII test procedure of FCC KDB-789033 for compliance to FCC 47CFR Subpart E requirements.

2.5. Uncertainty

± 2.26 dB

2.6. Test Result of Conducted Emission

Product : Wireless Access Point
 Test Item : Conducted Emission Test
 Power Line : Line 1
 Test Mode : Mode 2: Transmit (802.11n-20BW 14.4Mbps) (5260MHz) (Internal Antenna)

Frequency MHz	Correct Factor dB	Reading Level dBμV	Measurement Level dBμV	Margin dB	Limit dBμV
LINE 1					
Quasi-Peak					
0.181	9.662	36.400	46.062	-19.052	65.114
0.236	9.662	30.010	39.672	-23.871	63.543
0.291	9.665	30.540	40.205	-21.766	61.971
0.459	9.675	32.960	42.635	-14.536	57.171
0.685	9.687	25.220	34.907	-21.093	56.000
28.302	10.047	23.300	33.347	-26.653	60.000
Average					
0.181	9.662	23.980	33.642	-21.472	55.114
0.236	9.662	18.730	28.392	-25.151	53.543
0.291	9.665	19.820	29.485	-22.486	51.971
0.459	9.675	22.770	32.445	-14.726	47.171
0.685	9.687	14.780	24.467	-21.533	46.000
28.302	10.047	15.370	25.417	-24.583	50.000

Note:

1. All Reading Levels are Quasi-Peak and average value.
2. “■” means the worst emission level.
3. Measurement Level = Reading Level + Correct Factor

Product : Wireless Access Point
 Test Item : Conducted Emission Test
 Power Line : Line 2
 Test Mode : Mode 2: Transmit (802.11n-20BW 14.4Mbps) (5260MHz) (Internal Antenna)

Frequency MHz	Correct Factor dB	Reading Level dBμV	Measurement Level dBμV	Margin dB	Limit dBμV
LINE 2					
Quasi-Peak					
0.189	9.660	32.280	41.940	-22.946	64.886
0.306	9.666	32.030	41.696	-19.847	61.543
0.459	9.675	34.200	43.875	-13.296	57.171
0.806	9.693	25.730	35.423	-20.577	56.000
1.611	9.747	20.330	30.077	-25.923	56.000
27.955	10.274	21.970	32.244	-27.756	60.000
Average					
0.189	9.660	14.600	24.260	-30.626	54.886
0.306	9.666	24.660	34.326	-17.217	51.543
0.459	9.675	22.250	31.925	-15.246	47.171
0.806	9.693	15.300	24.993	-21.007	46.000
1.611	9.747	13.840	23.587	-22.413	46.000
27.955	10.274	16.090	26.364	-23.636	50.000

Note:

1. All Reading Levels are Quasi-Peak and average value.
2. “■” means the worst emission level.
3. Measurement Level = Reading Level + Correct Factor

Product : Wireless Access Point
 Test Item : Conducted Emission Test
 Power Line : Line 1
 Test Mode : Mode 2: Transmit (802.11n-20BW 14.4Mbps) (5500MHz) (Internal Antenna)

Frequency MHz	Correct Factor dB	Reading Level dBμV	Measurement Level dBμV	Margin dB	Limit dBμV
LINE 1					
Quasi-Peak					
0.177	9.663	36.720	46.383	-18.846	65.229
0.232	9.662	29.810	39.472	-24.185	63.657
0.310	9.666	30.440	40.106	-21.323	61.429
0.455	9.674	32.670	42.344	-14.942	57.286
0.810	9.694	25.340	35.034	-20.966	56.000
28.384	10.048	23.380	33.428	-26.572	60.000
Average					
0.177	9.663	30.100	39.763	-15.466	55.229
0.232	9.662	16.730	26.392	-27.265	53.657
0.310	9.666	18.910	28.576	-22.853	51.429
0.455	9.674	21.800	31.474	-15.812	47.286
0.810	9.694	12.950	22.644	-23.356	46.000
28.384	10.048	16.100	26.148	-23.852	50.000

Note:

1. All Reading Levels are Quasi-Peak and average value.
2. "■" means the worst emission level.
3. Measurement Level = Reading Level + Correct Factor

Product : Wireless Access Point
 Test Item : Conducted Emission Test
 Power Line : Line 2
 Test Mode : Mode 2: Transmit (802.11n-20BW 14.4Mbps) (5500MHz) (Internal Antenna)

Frequency MHz	Correct Factor dB	Reading Level dBμV	Measurement Level dBμV	Margin dB	Limit dBμV
LINE 2					
Quasi-Peak					
0.177	9.663	37.100	46.763	-18.466	65.229
0.306	9.666	32.070	41.736	-19.807	61.543
0.451	9.674	34.200	43.874	-13.526	57.400
0.841	9.695	25.790	35.485	-20.515	56.000
1.748	9.755	20.330	30.085	-25.915	56.000
27.818	10.273	21.880	32.153	-27.847	60.000
Average					
0.177	9.663	29.410	39.073	-16.156	55.229
0.306	9.666	24.250	33.916	-17.627	51.543
0.451	9.674	26.220	35.894	-11.506	47.400
0.841	9.695	15.870	25.565	-20.435	46.000
1.748	9.755	12.270	22.025	-23.975	46.000
27.818	10.273	13.070	23.343	-26.657	50.000

Note:

1. All Reading Levels are Quasi-Peak and average value.
2. “■” means the worst emission level.
3. Measurement Level = Reading Level + Correct Factor

Product : Wireless Access Point
 Test Item : Conducted Emission Test
 Power Line : Line 1
 Test Mode : Mode 3: Transmit (802.11n-40BW 30Mbps) (5230MHz) (Internal Antenna)

Frequency MHz	Correct Factor dB	Reading Level dBμV	Measurement Level dBμV	Margin dB	Limit dBμV
LINE 1					
Quasi-Peak					
0.173	9.664	36.600	46.264	-19.079	65.343
0.228	9.662	29.700	39.362	-24.409	63.771
0.341	9.668	27.460	37.128	-23.415	60.543
0.443	9.674	30.680	40.354	-17.275	57.629
0.834	9.695	25.500	35.195	-20.805	56.000
28.783	10.051	23.610	33.661	-26.339	60.000
Average					
0.173	9.664	30.730	40.394	-14.949	55.343
0.228	9.662	19.310	28.972	-24.799	53.771
0.341	9.668	18.770	28.438	-22.105	50.543
0.443	9.674	12.870	22.544	-25.085	47.629
0.834	9.695	13.690	23.385	-22.615	46.000
28.783	10.051	17.130	27.181	-22.819	50.000

Note:

1. All Reading Levels are Quasi-Peak and average value.
2. “█” means the worst emission level.
3. Measurement Level = Reading Level + Correct Factor

Product : Wireless Access Point
 Test Item : Conducted Emission Test
 Power Line : Line 2
 Test Mode : Mode 3: Transmit (802.11n-40BW 30Mbps) (5230MHz) (Internal Antenna)

Frequency MHz	Correct Factor dB	Reading Level dBμV	Measurement Level dBμV	Margin dB	Limit dBμV
LINE 2					
Quasi-Peak					
0.181	9.662	36.480	46.142	-18.972	65.114
0.236	9.662	28.750	38.412	-25.131	63.543
0.298	9.666	31.810	41.476	-20.295	61.771
0.463	9.675	34.220	43.895	-13.162	57.057
0.845	9.696	26.310	36.006	-19.994	56.000
27.970	10.274	23.110	33.384	-26.616	60.000
Average					
0.181	9.662	23.300	32.962	-22.152	55.114
0.236	9.662	19.610	29.272	-24.271	53.543
0.298	9.666	24.460	34.126	-17.645	51.771
0.463	9.675	22.250	31.925	-15.132	47.057
0.845	9.696	16.000	25.696	-20.304	46.000
27.970	10.274	15.300	25.574	-24.426	50.000

Note:

1. All Reading Levels are Quasi-Peak and average value.
2. “■” means the worst emission level.
3. Measurement Level = Reading Level + Correct Factor

Product : Wireless Access Point
 Test Item : Conducted Emission Test
 Power Line : Line 1
 Test Mode : Mode 6: Transmit (802.11ac-80BW-65Mbps) (5210MHz) (External Antenna)

Frequency MHz	Correct Factor dB	Reading Level dBμV	Measurement Level dBμV	Margin dB	Limit dBμV
LINE 1					
Quasi-Peak					
0.173	9.664	39.050	48.714	-16.629	65.343
0.220	9.662	27.580	37.242	-26.758	64.000
0.306	9.666	32.470	42.136	-19.407	61.543
0.463	9.675	34.480	44.155	-12.902	57.057
0.838	9.695	26.560	36.255	-19.745	56.000
28.470	10.049	23.200	33.249	-26.751	60.000
Average					
0.173	9.664	32.990	42.654	-12.689	55.343
0.220	9.662	11.350	21.012	-32.988	54.000
0.306	9.666	14.980	24.646	-26.897	51.543
0.463	9.675	22.950	32.625	-14.432	47.057
0.838	9.695	14.370	24.065	-21.935	46.000
28.470	10.049	16.010	26.059	-23.941	50.000

Note:

1. All Reading Levels are Quasi-Peak and average value.
2. “■” means the worst emission level.
3. Measurement Level = Reading Level + Correct Factor

Product : Wireless Access Point
 Test Item : Conducted Emission Test
 Power Line : Line 2
 Test Mode : Mode 6: Transmit (802.11ac-80BW-65Mbps) (5210MHz) (External Antenna)

Frequency MHz	Correct Factor dB	Reading Level dBμV	Measurement Level dBμV	Margin dB	Limit dBμV
LINE 2					
Quasi-Peak					
0.173	9.664	37.280	46.944	-18.399	65.343
0.244	9.663	30.820	40.483	-22.831	63.314
0.306	9.666	32.090	41.756	-19.787	61.543
0.466	9.675	33.180	42.855	-14.116	56.971
0.810	9.694	25.790	35.484	-20.516	56.000
27.396	10.259	23.230	33.489	-26.511	60.000
Average					
0.173	9.664	24.280	33.944	-21.399	55.343
0.244	9.663	22.880	32.543	-20.771	53.314
0.306	9.666	21.620	31.286	-20.257	51.543
0.466	9.675	23.880	33.555	-13.416	46.971
0.810	9.694	15.590	25.284	-20.716	46.000
27.396	10.259	17.590	27.849	-22.151	50.000

Note:

1. All Reading Levels are Quasi-Peak and average value.
2. “█” means the worst emission level.
3. Measurement Level = Reading Level + Correct Factor

Product : Wireless Access Point
 Test Item : Conducted Emission Test
 Power Line : Line 1
 Test Mode : Mode 6: Transmit (802.11ac-80BW-65Mbps) (5290MHz) (External Antenna)

Frequency MHz	Correct Factor dB	Reading Level dBμV	Measurement Level dBμV	Margin dB	Limit dBμV
LINE 1					
Quasi-Peak					
0.173	9.664	38.810	48.474	-16.869	65.343
0.240	9.663	30.340	40.003	-23.426	63.429
0.295	9.666	31.730	41.396	-20.461	61.857
0.470	9.675	34.470	44.145	-12.712	56.857
0.838	9.695	26.740	36.435	-19.565	56.000
6.814	9.893	15.340	25.233	-34.767	60.000
Average					
0.173	9.664	29.330	38.994	-16.349	55.343
0.240	9.663	19.840	29.503	-23.926	53.429
0.295	9.666	23.880	33.546	-18.311	51.857
0.470	9.675	23.180	32.855	-14.002	46.857
0.838	9.695	14.800	24.495	-21.505	46.000
6.814	9.893	10.760	20.653	-29.347	50.000

Note:

1. All Reading Levels are Quasi-Peak and average value.
2. “█” means the worst emission level.
3. Measurement Level = Reading Level + Correct Factor

Product : Wireless Access Point
 Test Item : Conducted Emission Test
 Power Line : Line 2
 Test Mode : Mode 6: Transmit (802.11ac-80BW-65Mbps) (5290MHz) (External Antenna)

Frequency MHz	Correct Factor dB	Reading Level dBμV	Measurement Level dBμV	Margin dB	Limit dBμV
LINE 2					
Quasi-Peak					
0.181	9.662	36.740	46.402	-18.712	65.114
0.228	9.662	30.630	40.292	-23.479	63.771
0.291	9.665	31.190	40.855	-21.116	61.971
0.463	9.675	33.980	43.655	-13.402	57.057
0.822	9.694	26.580	36.274	-19.726	56.000
28.998	10.282	21.020	31.302	-28.698	60.000
Average					
0.181	9.662	24.490	34.152	-20.962	55.114
0.228	9.662	19.620	29.282	-24.489	53.771
0.291	9.665	18.100	27.765	-24.206	51.971
0.463	9.675	23.730	33.405	-13.652	47.057
0.822	9.694	13.980	23.674	-22.326	46.000
28.998	10.282	15.780	26.062	-23.938	50.000

Note:

1. All Reading Levels are Quasi-Peak and average value.
2. “█” means the worst emission level.
3. Measurement Level = Reading Level + Correct Factor

Product : Wireless Access Point
 Test Item : Conducted Emission Test
 Power Line : Line 1
 Test Mode : Mode 6: Transmit (802.11ac-80BW-65Mbps) (5530MHz) (External Antenna)

Frequency MHz	Correct Factor dB	Reading Level dBμV	Measurement Level dBμV	Margin dB	Limit dBμV
LINE 1					
Quasi-Peak					
0.173	9.664	38.690	48.354	-16.989	65.343
0.283	9.665	31.280	40.945	-21.255	62.200
0.447	9.674	33.940	43.614	-13.900	57.514
0.810	9.694	27.210	36.904	-19.096	56.000
1.298	9.720	23.690	33.410	-22.590	56.000
28.591	10.050	23.550	33.600	-26.400	60.000
Average					
0.173	9.664	34.870	44.534	-10.809	55.343
0.283	9.665	22.780	32.445	-19.755	52.200
0.447	9.674	24.170	33.844	-13.670	47.514
0.810	9.694	14.690	24.384	-21.616	46.000
1.298	9.720	12.930	22.650	-23.350	46.000
28.591	10.050	13.980	24.030	-25.970	50.000

Note:

1. All Reading Levels are Quasi-Peak and average value.
2. “█” means the worst emission level.
3. Measurement Level = Reading Level + Correct Factor

Product : Wireless Access Point
 Test Item : Conducted Emission Test
 Power Line : Line 2
 Test Mode : Mode 6: Transmit (802.11ac-80BW-65Mbps) (5530MHz) (External Antenna)

Frequency MHz	Correct Factor dB	Reading Level dBμV	Measurement Level dBμV	Margin dB	Limit dBμV
LINE 2					
Quasi-Peak					
0.181	9.662	36.740	46.402	-18.712	65.114
0.236	9.662	30.870	40.532	-23.011	63.543
0.306	9.666	32.310	41.976	-19.567	61.543
0.466	9.675	33.340	43.015	-13.956	56.971
0.822	9.694	26.660	36.354	-19.646	56.000
27.509	10.270	23.250	33.520	-26.480	60.000
Average					
0.181	9.662	31.500	41.162	-13.952	55.114
0.236	9.662	21.820	31.482	-22.061	53.543
0.306	9.666	24.870	34.536	-17.007	51.543
0.466	9.675	23.340	33.015	-13.956	46.971
0.822	9.694	13.980	23.674	-22.326	46.000
27.509	10.270	16.900	27.170	-22.830	50.000

Note:

1. All Reading Levels are Quasi-Peak and average value.
2. “█” means the worst emission level.
3. Measurement Level = Reading Level + Correct Factor

3. Maximun conducted output power

3.1. Test Equipment

	Equipment	Manufacturer	Model No./Serial No.	Last Cal.
X	Power Meter	Anritsu	ML2495A/6K00003357	May, 2014
X	Power Sensor	Anritsu	MA2411B/0738448	Jun., 2014
X	Spectrum Analyzer	Agilent	N9010A / MY48030495	Apr., 2014

Note:

1. All equipments are calibrated with traceable calibrations. Each calibration is traceable to the national or international standards.
2. The test instruments marked with “X” are used to measure the final test results.

3.2. Test Setup

26dBc Occupied Bandwidth

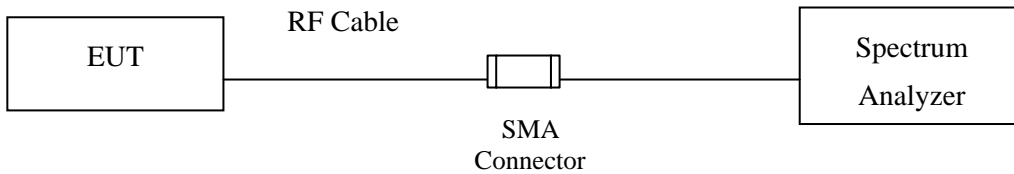

Conduction Power Measurement (for 802.11a)

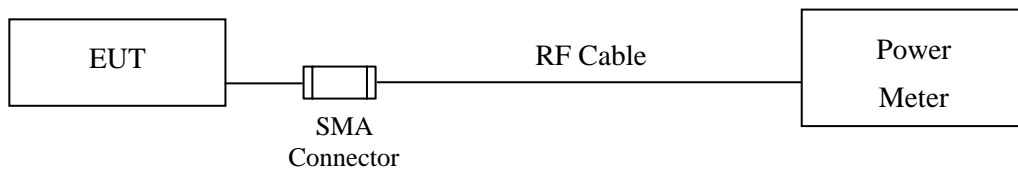

Conduction Power Measurement (for 802.11ac)

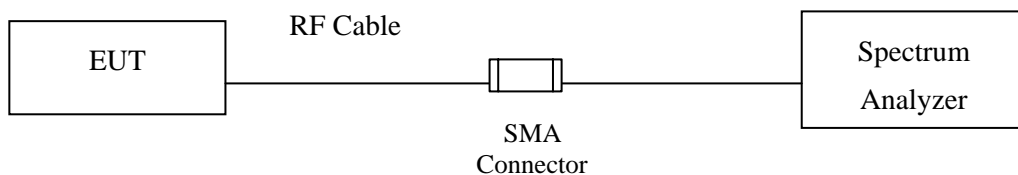

3.3. Limits

- (1) For the band 5.15-5.25 GHz, the maximum conducted output power over the frequency band of operation shall not exceed the lesser of 50 mW or $4 \text{ dBm} + 10\log B$, where B is the 26-dB emission bandwidth in MHz. If transmitting antenna of directional gain greater than 6 dBi are used, the peak transmit power shall be reduced by the amount in dB that directional gain of the antenna exceeds 6 dBi.
- (2) For the band 5.25-5.35 GHz, the maximum conducted output power over the frequency band of operation shall not exceed the lesser of 250 mW or $11 \text{ dBm} + 10\log B$, where B is the 26-dB emission bandwidth in MHz. If transmitting antenna of directional gain greater than 6 dBi are used, the peak transmit power shall be reduced by the amount in dB that directional gain of the antenna exceeds 6 dBi.
- (3) For the band 5.725-5.825 GHz, the maximum conducted output power over the frequency band of operation shall not exceed the lesser of 1W or $17 \text{ dBm} + 10\log B$, where B is the 26-dB emission bandwidth in MHz. If transmitting antenna of directional gain greater than 6 dBi are used, the peak transmit power shall be reduced by the amount in dB that directional gain of the antenna exceeds 6 dBi.

3.4. Test Procedur

As an alternative to FCC KDB-789033, the EUT maximum conducted output power was measured with an average power meter employing a video bandwidth greater than 6dB BW of the emission under test. Maximum conducted output power was read directly from the meter across all data rates, and across three channels within each sub-band. Special care was used to make sure that the EUT was transmitting in continuous mode. This method exceeds the limitations of FCC KDB-789033, and provides more accurate measurements.

802.11a (BW \leq 40MHz) Maximum conducted output power using KDB 789033 section E)3)a)

Method PM (Measurement using an RF average power meter):

Note: the power meter have a video bandwidth that is greater than or equal to the measurement bandwidth, (Anritsu/ MA2411B video bandwidth: 50MHz)

802.11ac (BW=80MHz) Maximum conducted output power using KDB 789033 section E)2)b)

Method SA-1 (trace averaging with the EUT transmitting at full power throughout each sweep).

When transmitted signals consist of two or more non-contiguous spectrum segments (e.g., 80+80 MHz mode) or when a single spectrum segment of a transmission crosses the boundary between two adjacent U-NII bands, KDB 644545 D01 section F) procedure is used for measurements.

3.5. Uncertainty

Power sensor/meter method: ± 0.517 dB

Spectrum analyzer method: ± 1.27 dB

3.6. Test Result of Maximum conducted output power

Product : Wireless Access Point
 Test Item : Maximum conducted output power
 Test Site : No.3 OATS
 Test Mode : Mode 1: Transmit (802.11a-6Mbps) (Internal Antenna)

CHAIN A

Cable loss=1dB		Maximum conducted output power								
Channel No.	Frequency (MHz)	Data Rate (Mbps)								Required Limit
		6	9	12	18	24	36	48	54	
		Measurement Level (dBm)								
36	5180	9.58	--	--	--	--	--	--	--	<17dBm
44	5220	9.91	9.82	9.71	9.64	9.52	9.46	9.35	9.22	<17dBm
48	5240	10.08	--	--	--	--	--	--	--	<17dBm
52	5260	10.25	--	--	--	--	--	--	--	<24dBm
60	5300	10.37	10.27	10.15	10.08	9.95	9.82	9.74	9.67	<24dBm
64	5320	10.27	--	--	--	--	--	--	--	<24dBm
100	5500	12.07	--	--	--	--	--	--	--	<24dBm
116	5580	12.4	12.29	12.17	12.04	11.95	11.87	11.74	11.61	<24dBm
140	5700	11.01	--	--	--	--	--	--	--	<24dBm

Note: Maximum conducted output power Value =Reading value on average power meter + cable loss

CHAIN B

Cable loss=1dB		Maximum conducted output power								
Channel No.	Frequency (MHz)	Data Rate (Mbps)								Required Limit
		6	9	12	18	24	36	48	54	
		Measurement Level (dBm)								
36	5180	9.44	--	--	--	--	--	--	--	<17dBm
44	5220	9.84	9.71	9.65	9.54	9.41	9.28	9.14	9.08	<17dBm
48	5240	10.91	--	--	--	--	--	--	--	<17dBm
52	5260	10.09	--	--	--	--	--	--	--	<24dBm
60	5300	10.24	10.18	10.02	9.94	9.81	9.74	9.66	9.53	<24dBm
64	5320	10.11	--	--	--	--	--	--	--	<24dBm
100	5500	11.94	--	--	--	--	--	--	--	<24dBm
116	5580	12.35	12.18	12.05	11.93	11.82	11.77	11.61	11.51	<24dBm
140	5700	10.88	--	--	--	--	--	--	--	<24dBm

Note: Maximum conducted output power Value =Reading value on average power meter + cable loss

Maximum conducted output power Measurement:

Channel No	Frequency Range (MHz)	26dB Bandwidth (MHz)	Output Power (dBm)	Output Power Limit	
				(dBm)	dBm+10log(BW)
36	5180	24.150	9.58	17	17.83
44	5220	23.500	9.91	17	17.71
48	5240	23.950	10.08	17	17.79
52	5260	23.150	10.25	24	24.65
60	5300	23.900	10.37	24	24.78
64	5320	23.050	10.27	24	24.63
100	5500	24.150	12.07	24	24.83
116	5580	23.500	12.4	24	24.71
140	5700	22.800	11.01	24	24.58

Note:

1. Power Output Value =Reading value on average power meter + cable loss
2. 26 dB Bandwidth is the bandwidth of chain A or chain B whichever is less bandwidth, output power limitation is more stringent.

26dBc Occupied Bandwidth:
Channel 36:

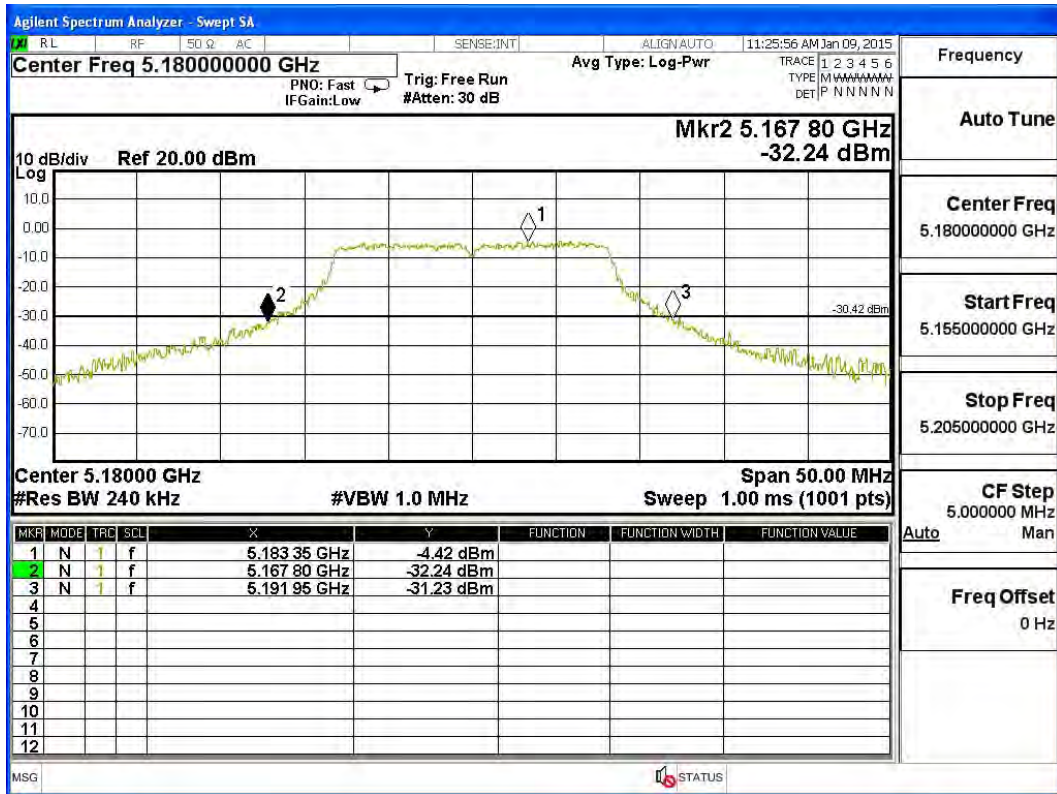

Channel 44:

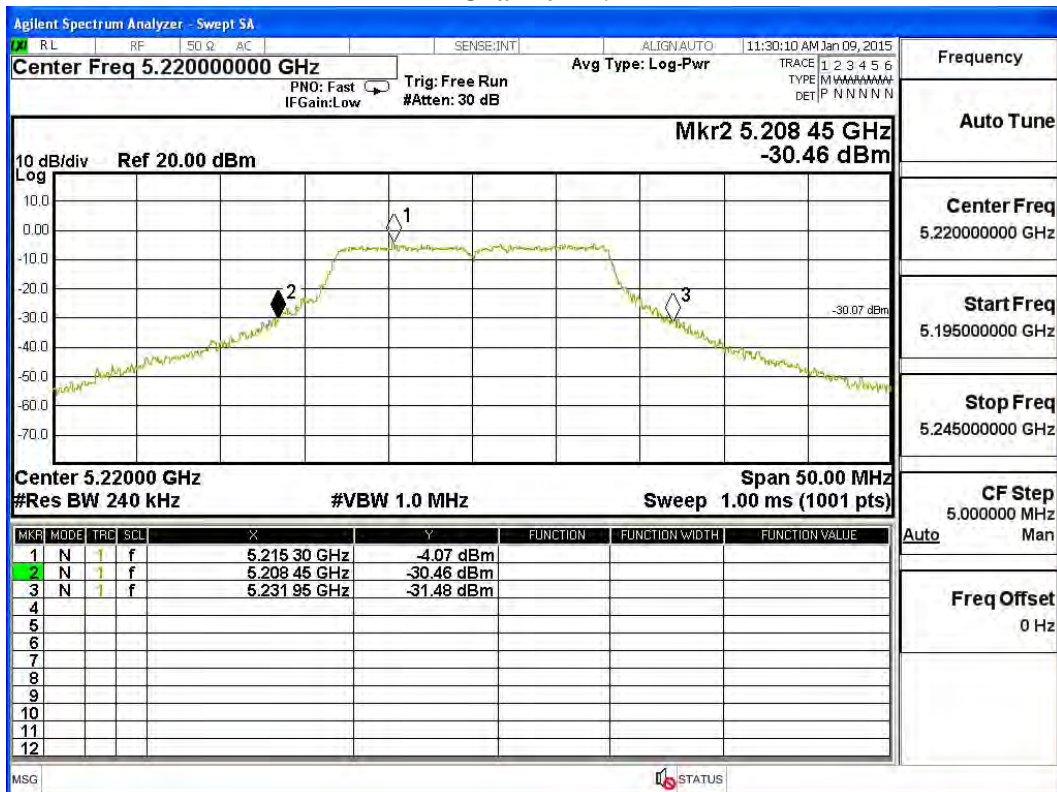

Channel 48:

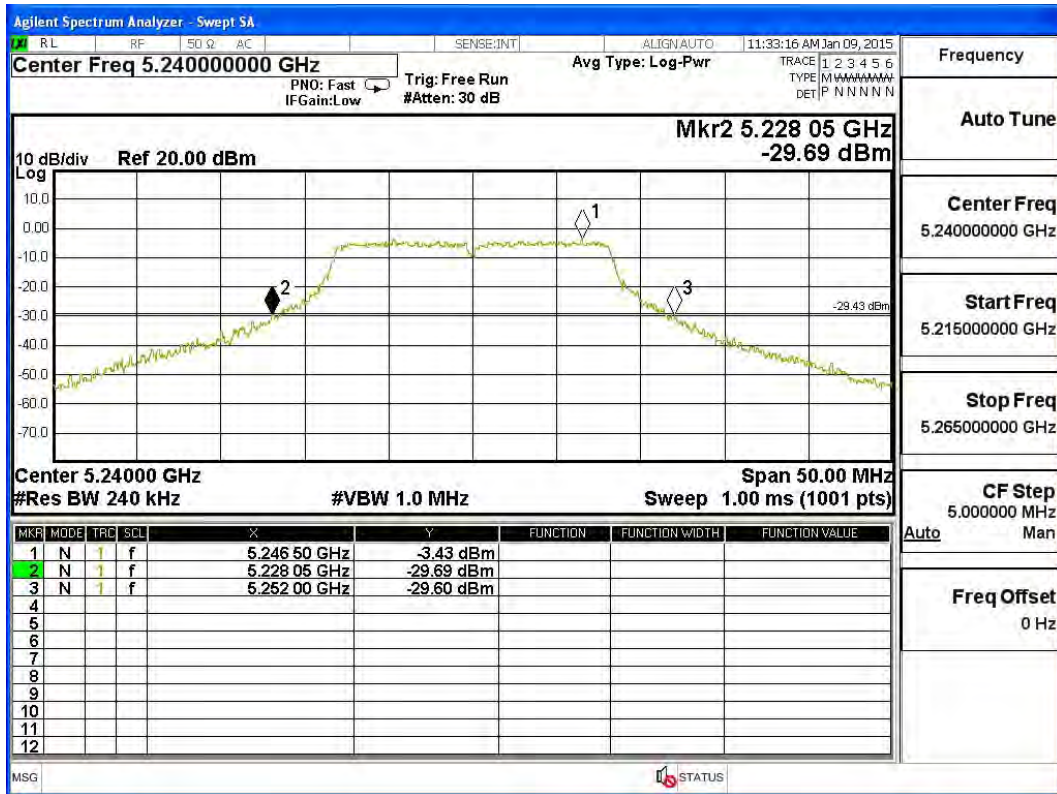

Channel 52:

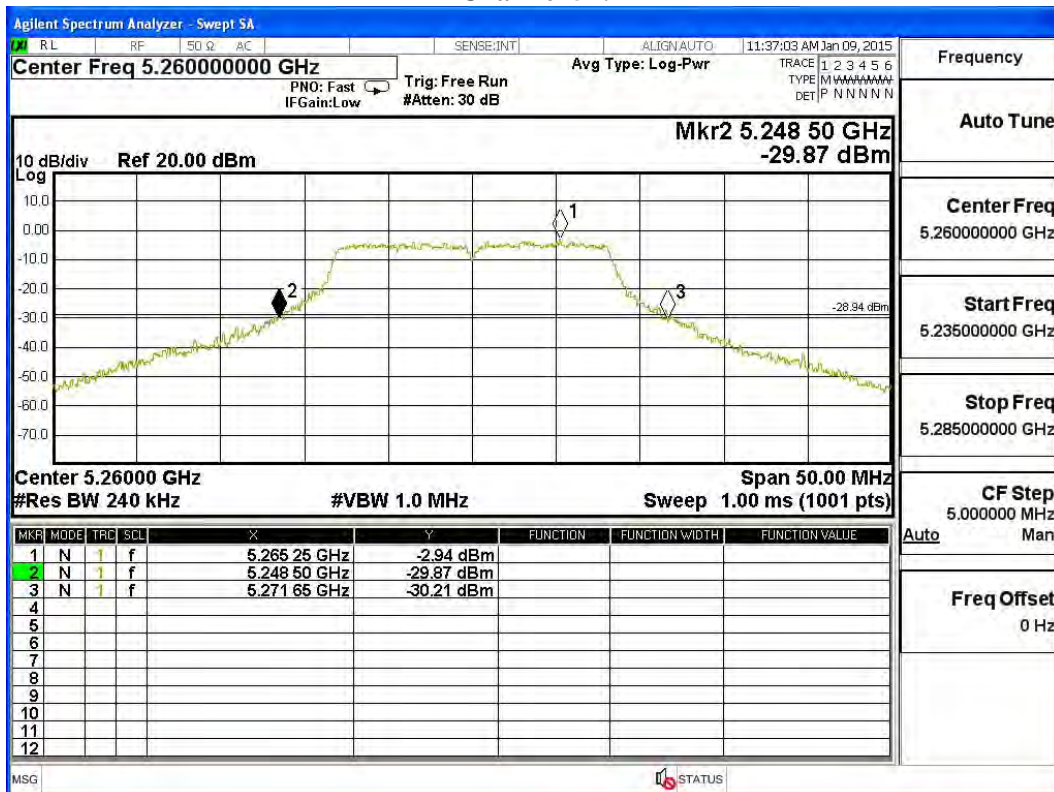

Channel 60:

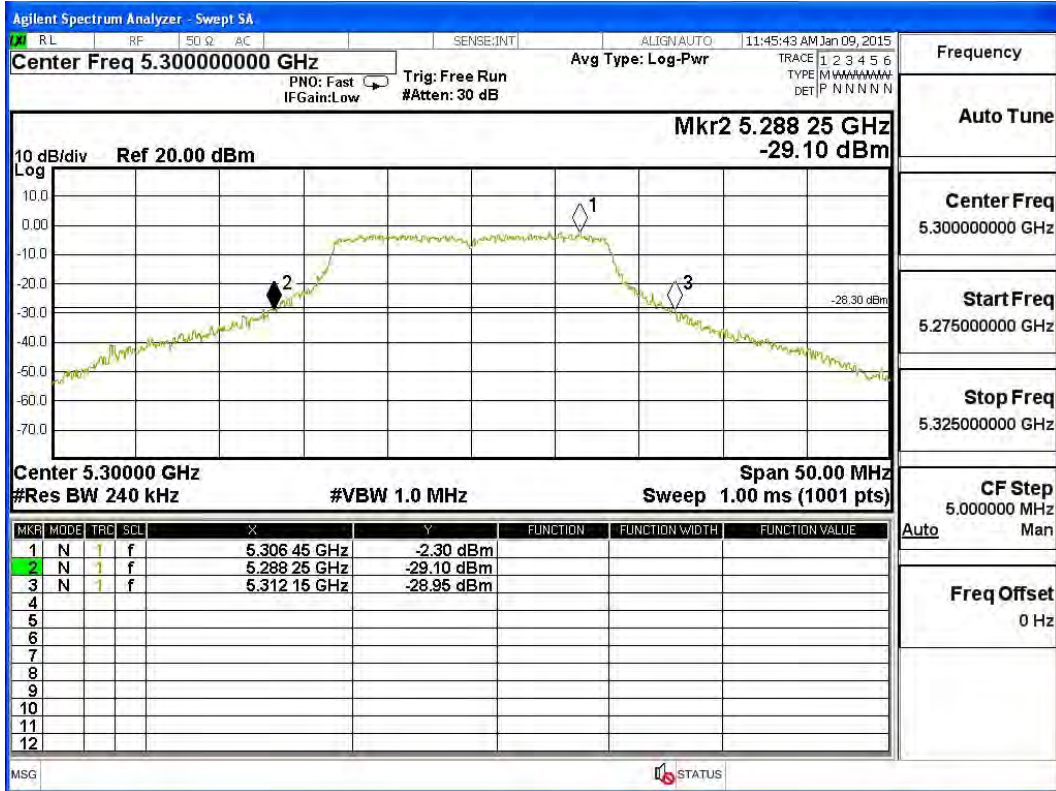

Channel 64:

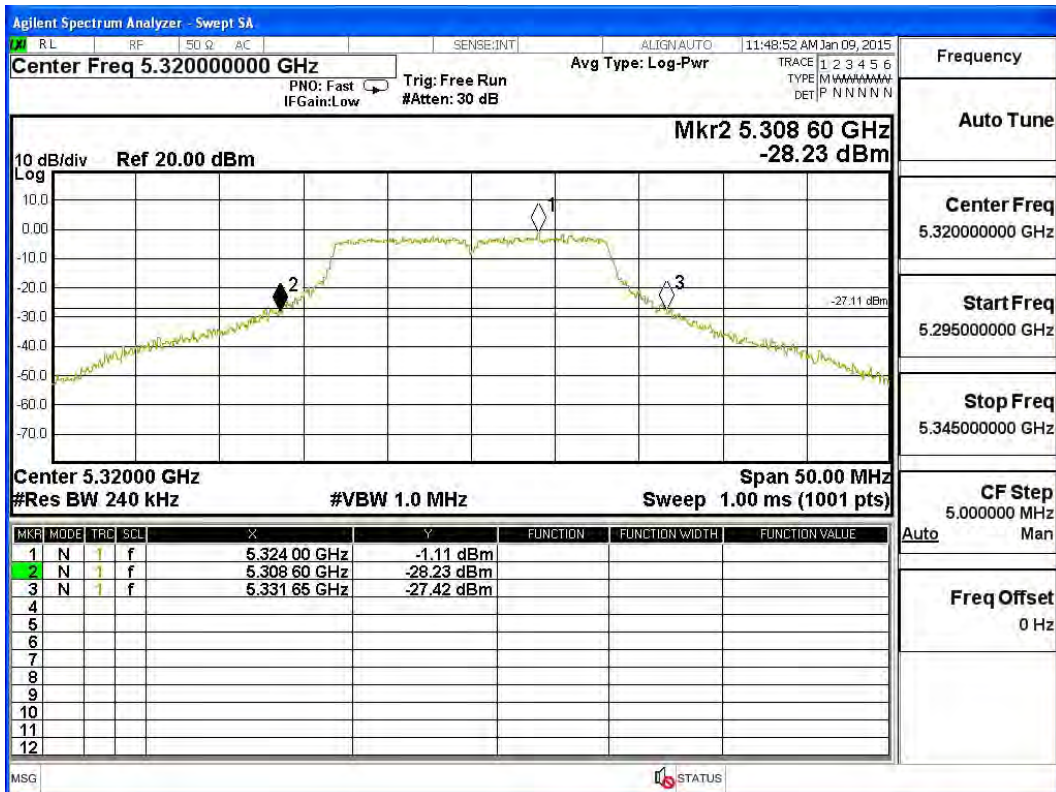

Channel 100:

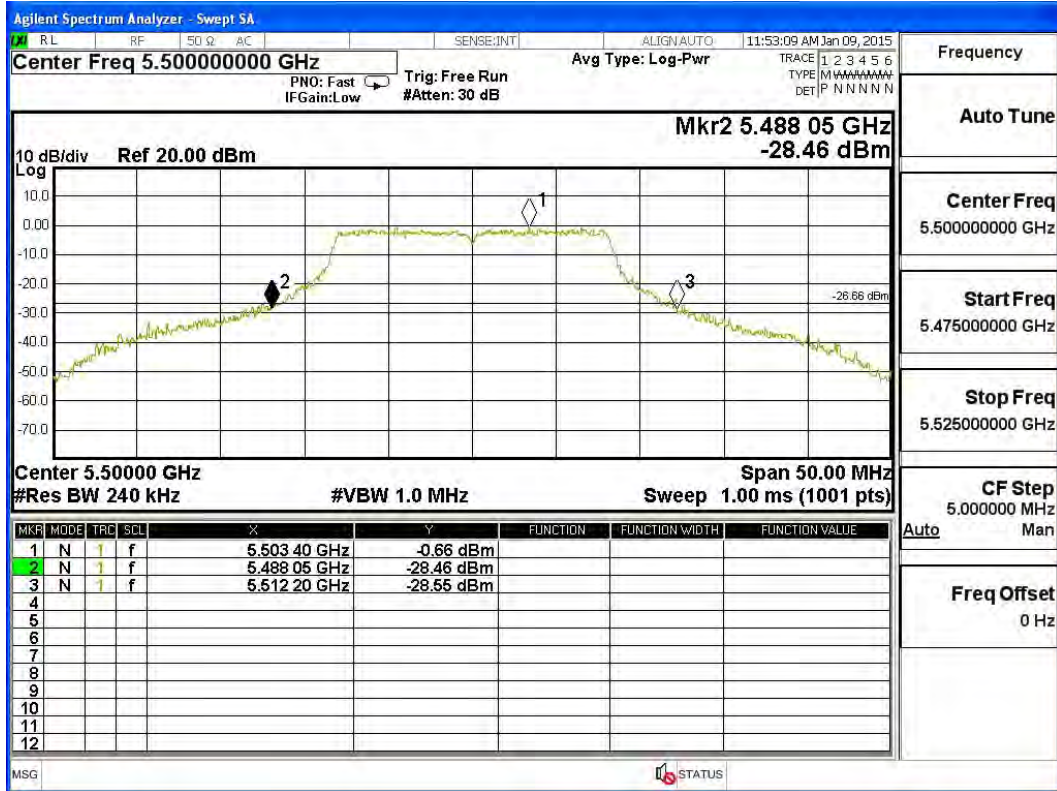

Channel 116:

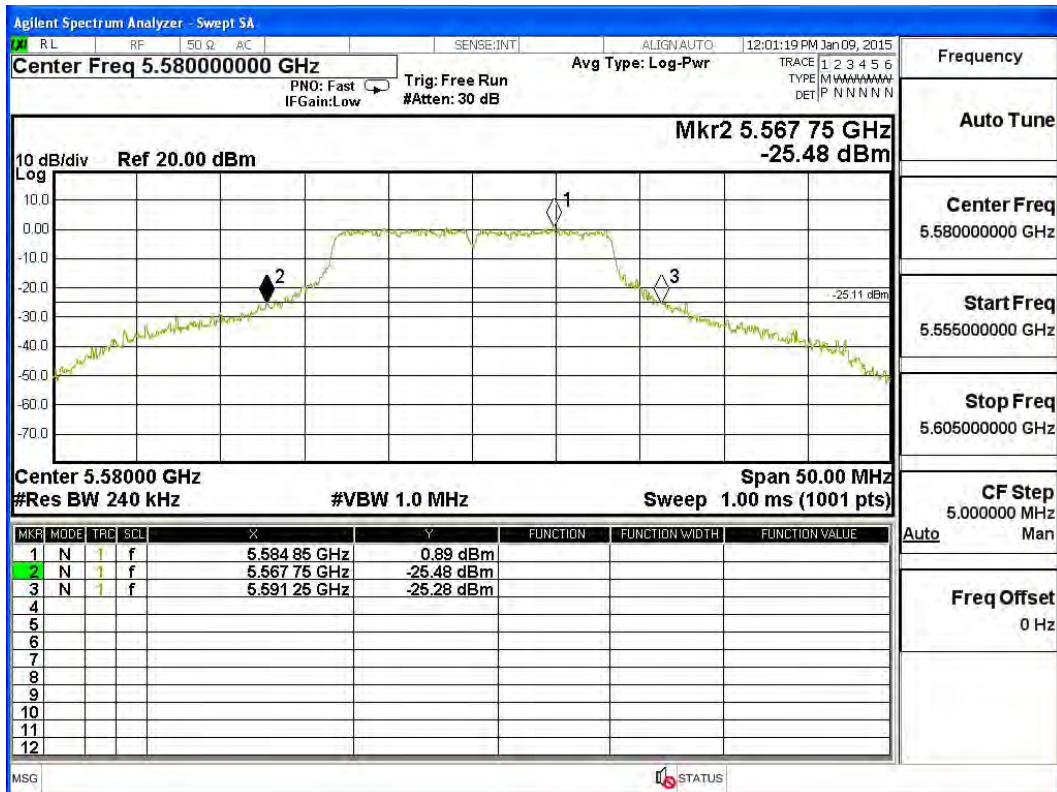

Channel 140:

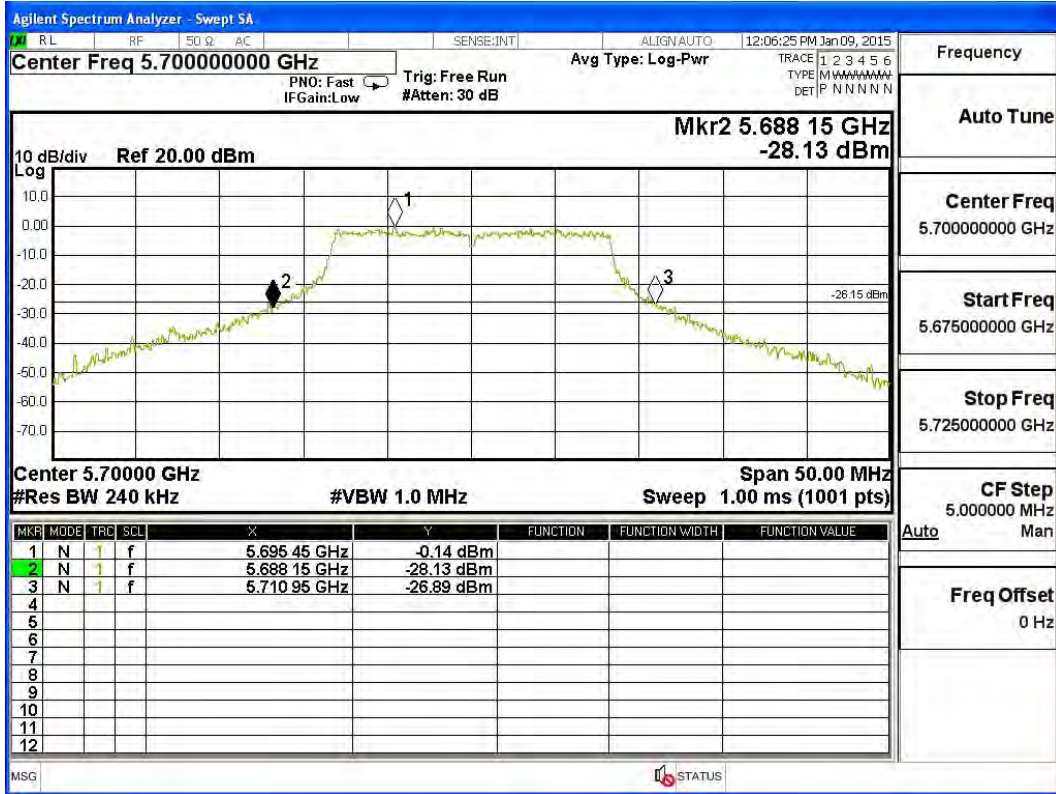

Product : Wireless Access Point
 Test Item : Maximum conducted output power
 Test Site : No.3 OATS
 Test Mode : Mode 2: Transmit (802.11n-20BW 14.4Mbps) (Internal Antenna)

CHAIN A

Cable loss=1dB		Maximum conducted output power								
Channel No.	Frequency (MHz)	Data Rate (Mbps)								Required Limit
		14.4	28.9	43.3	57.8	86.7	115.6	130	144.4	
		Measurement Level (dBm)								
36	5180	10.32	--	--	--	--	--	--	--	<17dBm
44	5220	10.63	10.56	10.47	10.41	10.35	10.25	10.21	10.12	<17dBm
48	5240	10.37	--	--	--	--	--	--	--	<17dBm
52	5260	10.55	--	--	--	--	--	--	--	<24dBm
60	5300	9.96	9.88	9.8	9.77	9.64	9.52	9.48	9.35	<24dBm
64	5320	10.06	--	--	--	--	--	--	--	<24dBm
100	5500	12.92	--	--	--	--	--	--	--	<24dBm
116	5580	13.23	13.15	13.05	12.97	12.91	12.83	12.75	12.63	<24dBm
140	5700	9.91	--	--	--	--	--	--	--	<24dBm

Note: Maximum conducted output power Value =Reading value on average power meter + cable loss

CHAIN B

Cable loss=1dB		Maximum conducted output power								
Channel No.	Frequency (MHz)	Data Rate (Mbps)								Required Limit
		14.4	28.9	43.3	57.8	86.7	115.6	130	144.4	
		Measurement Level (dBm)								
36	5180	10.81	--	--	--	--	--	--	--	<17dBm
44	5220	10.1	9.94	9.78	9.67	9.46	9.3	9.12	8.93	<17dBm
48	5240	9.35	--	--	--	--	--	--	--	<17dBm
52	5260	9.33	--	--	--	--	--	--	--	<24dBm
60	5300	9.66	9.51	9.36	9.22	9.06	8.94	8.76	8.58	<24dBm
64	5320	9.91	--	--	--	--	--	--	--	<24dBm
100	5500	12.25	--	--	--	--	--	--	--	<24dBm
116	5580	13.46	13.37	13.27	13.15	13.1	13.01	12.98	12.82	<24dBm
140	5700	9.69	--	--	--	--	--	--	--	<24dBm

Note: Maximum conducted output power Value =Reading value on average power meter + cable loss

Maximum conducted output power Measurement:

(CHAIN A+ B)

Channel Number	Frequency (MHz)	26dB Bandwidth (MHz)	Chain A Power (dBm)	Chain B Power (dBm)	Output Power (dBm)	Output Power Limit	
						(dBm)	dBm+10log(BW)
36	5180	23.300	10.32	10.81	13.58	17	17.67
44	5220	23.250	10.63	10.10	13.38	17	17.66
48	5240	23.000	10.37	9.35	12.90	17	17.62
52	5260	23.400	10.55	9.33	12.99	24	24.69
60	5300	23.750	9.96	9.66	12.82	24	24.76
64	5320	24.000	10.06	9.91	13.00	24	24.80
100	5500	23.900	12.92	12.25	15.61	24	24.78
116	5580	25.050	13.23	13.46	16.36	24	24.99
140	5700	24.150	9.91	9.69	12.81	24	24.83

Note:

1. Power Output Value =Reading value on average power meter + cable loss
2. Output Power (dBm) = 10LOG (Chain A Power (mW)+ Chain B Power (mW))
3. 26 dB Bandwidth is the bandwidth of chain A or chain B whichever is less bandwidth, output power limitation is more stringent.

26dBc Occupied Bandwidth:
Channel 36 -Chain A

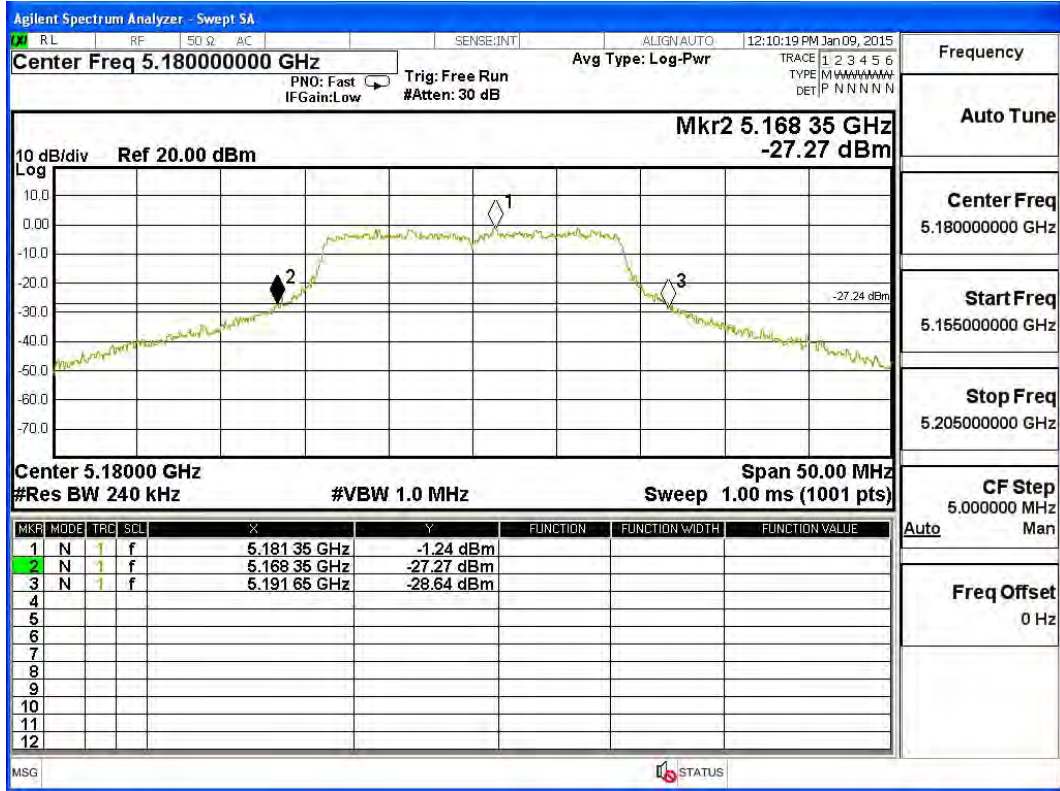

Channel 44 -Chain A

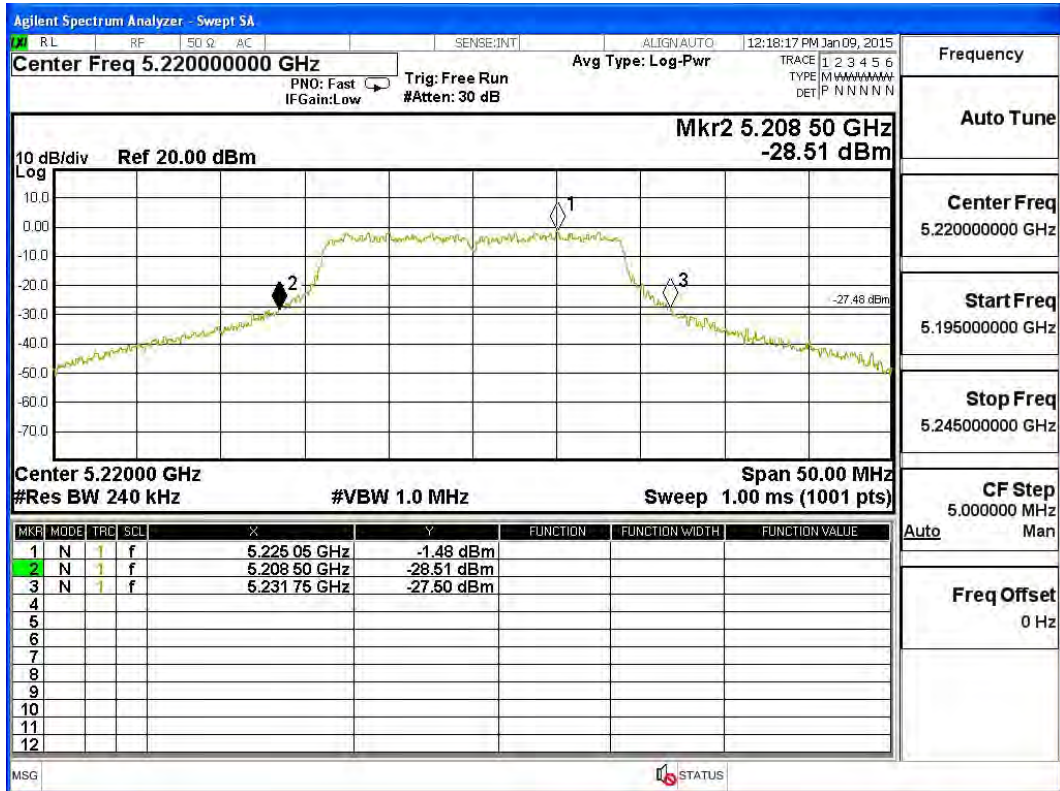

Channel 48 -Chain A

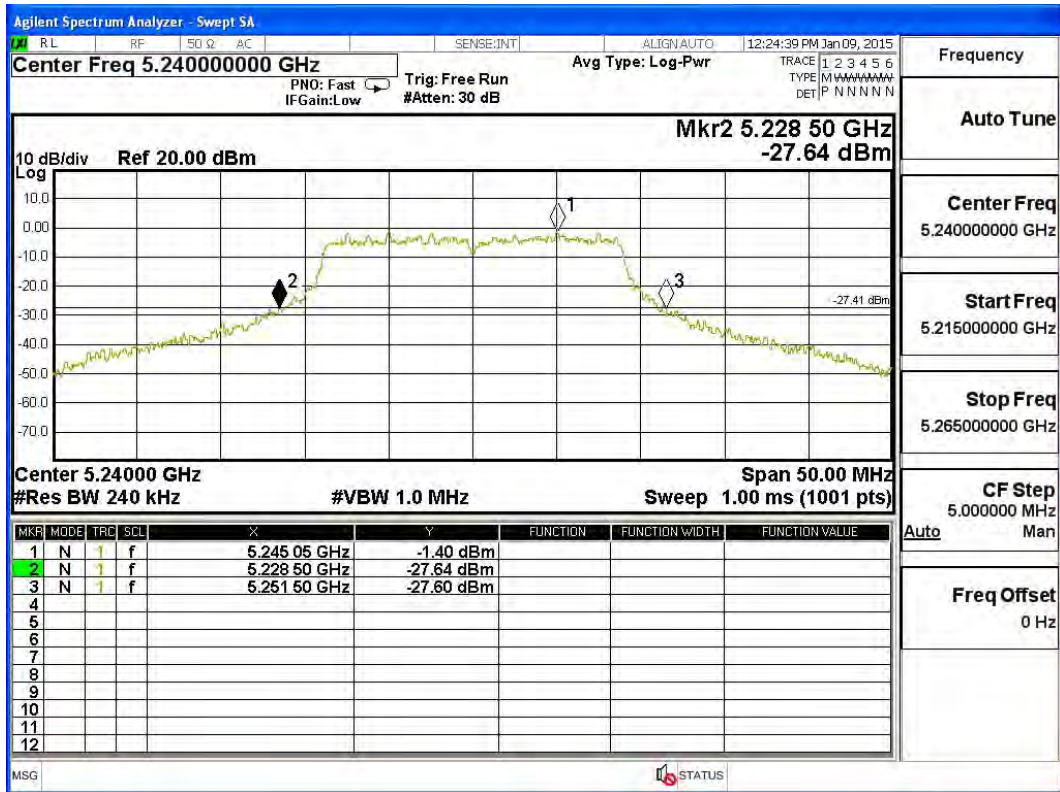

Channel 52 -Chain A

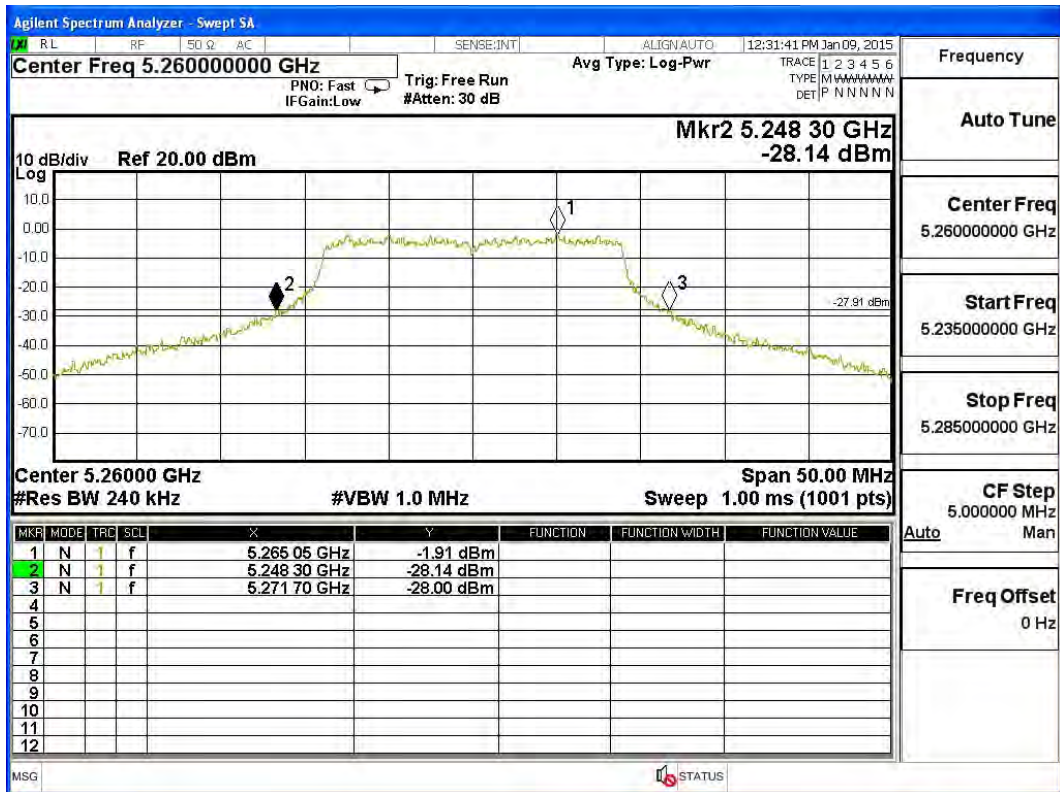

Channel 60 -Chain A

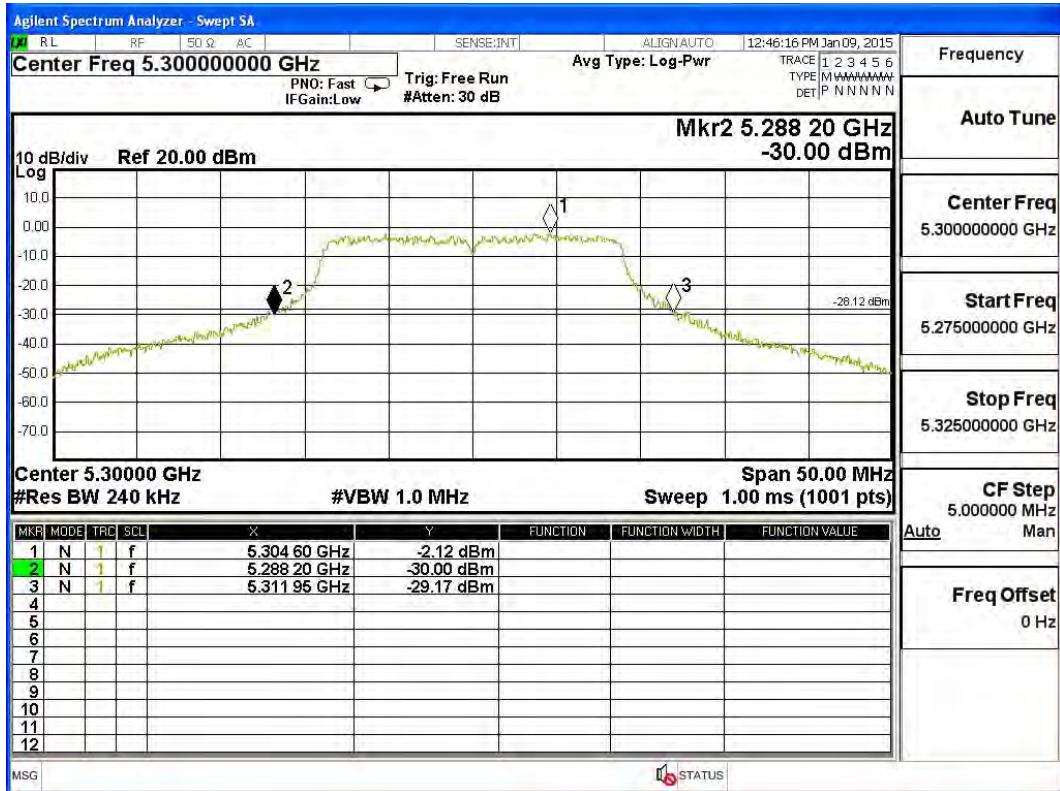

Channel 64 -Chain A

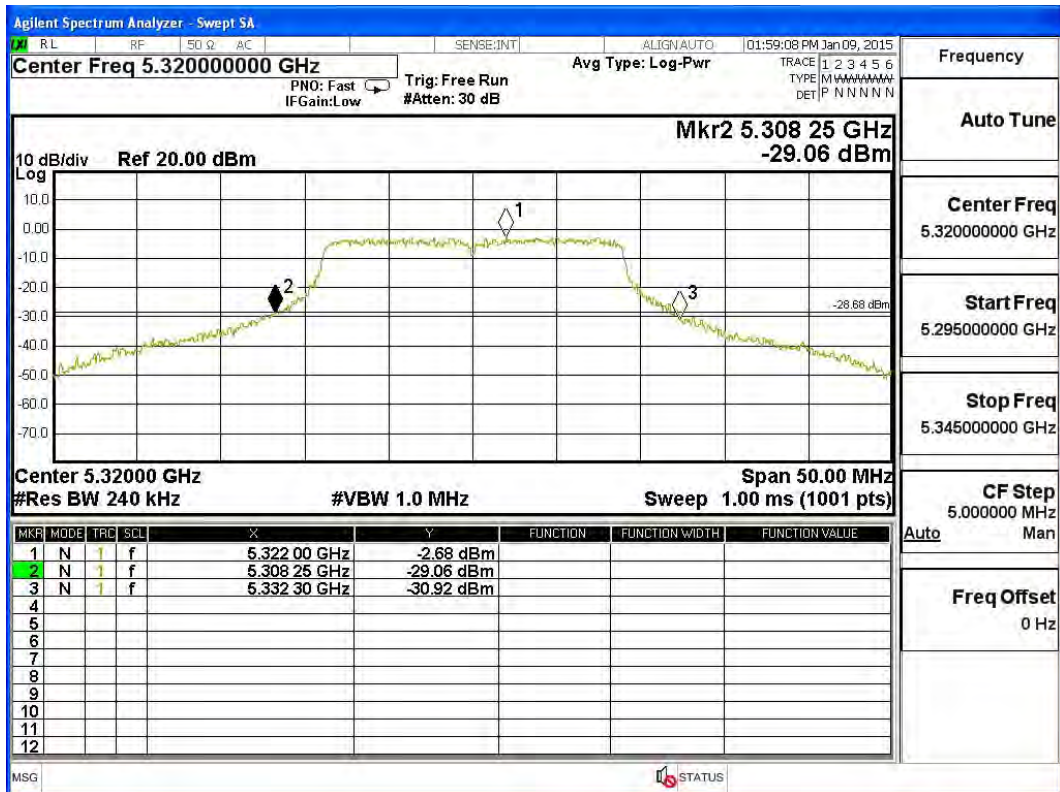

Channel 100 -Chain A

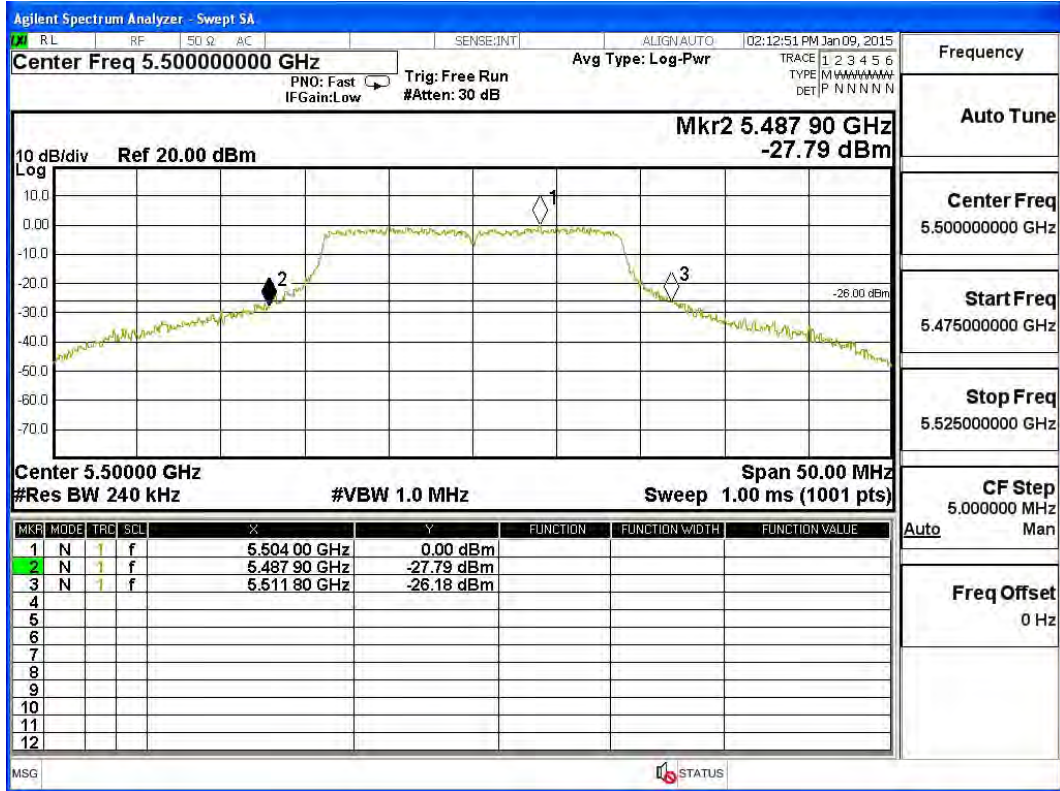

Channel 116 -Chain A

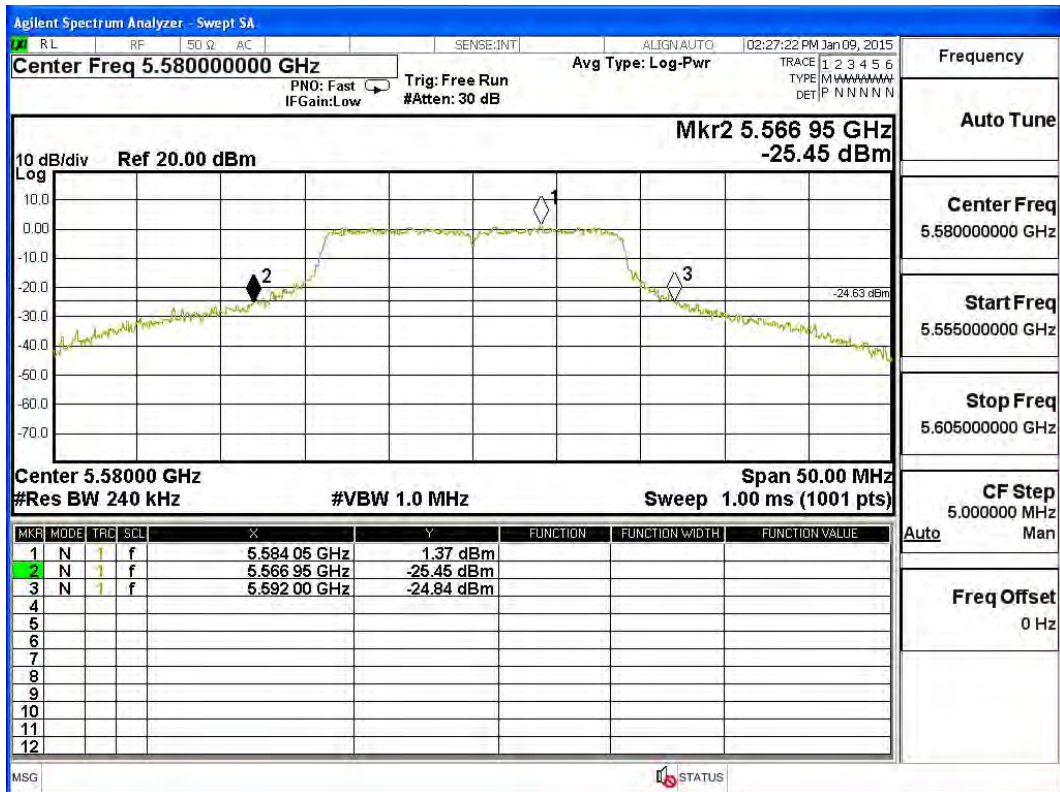

Channel 140 -Chain A

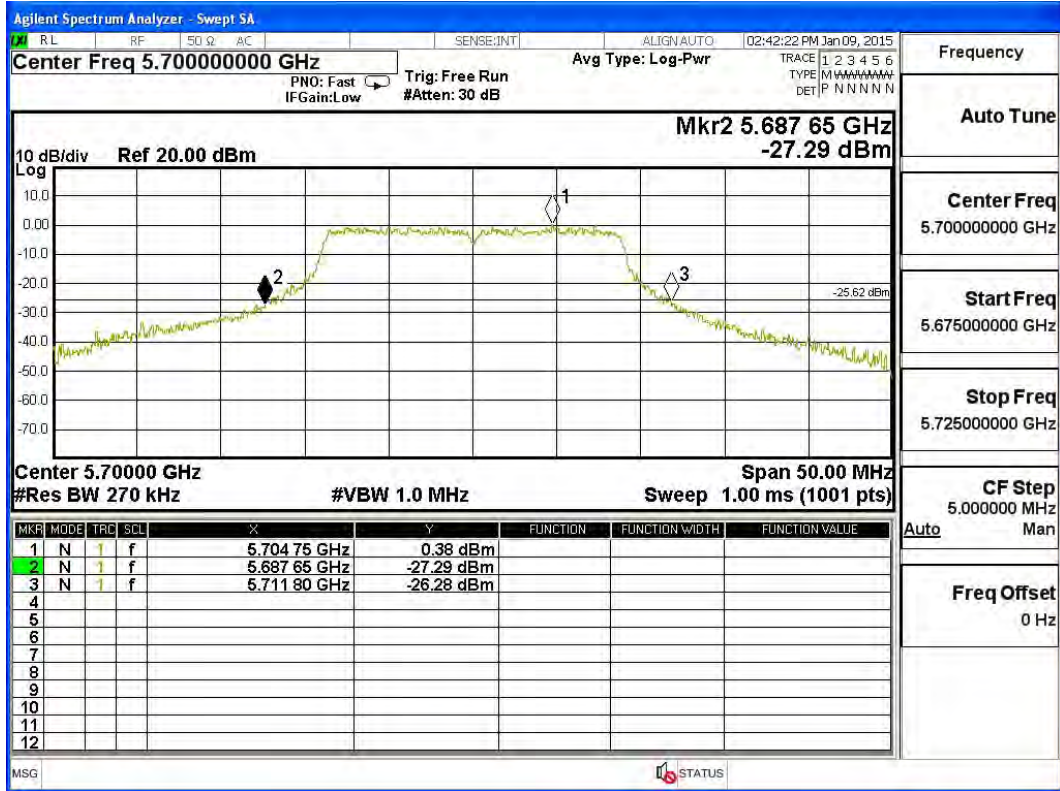

26dBc Occupied Bandwidth:
Channel 36 -Chain B

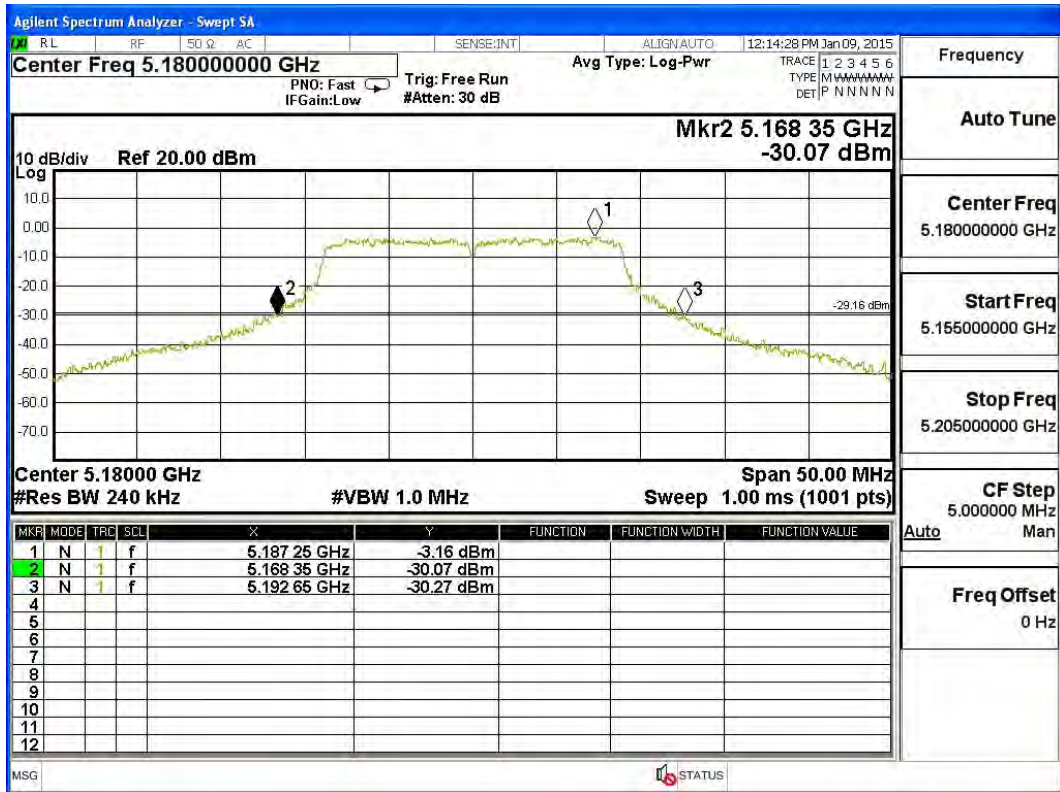

Channel 44 -Chain B

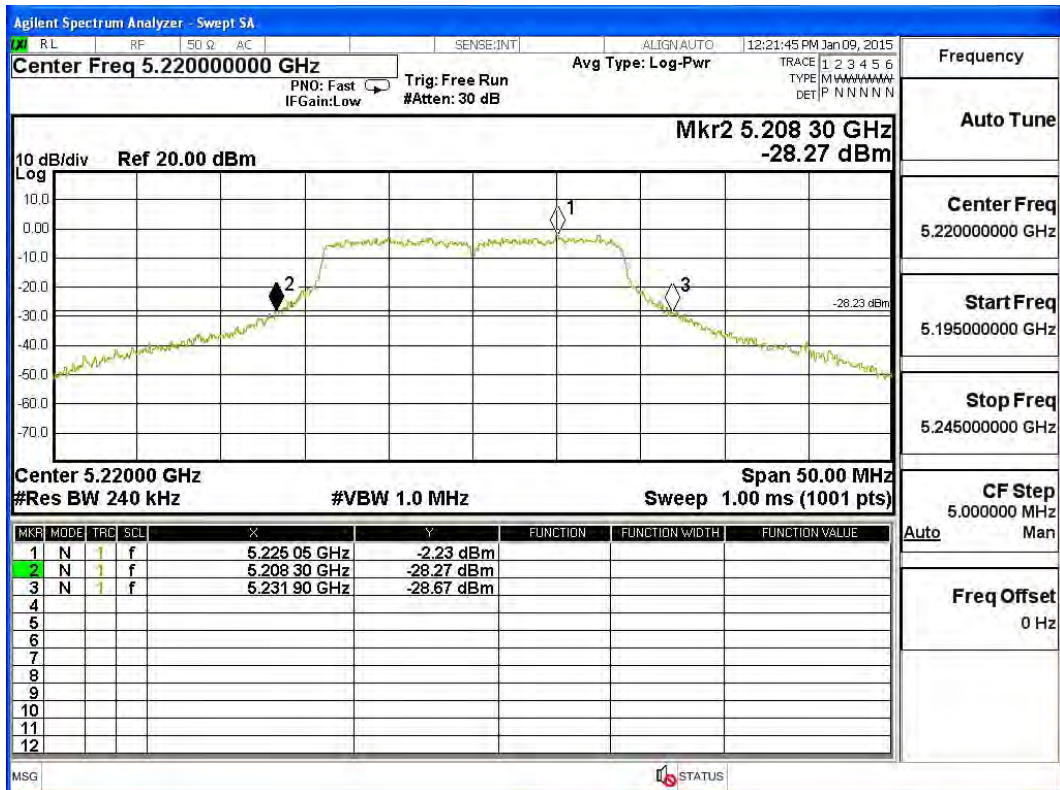

Channel 48 -Chain B

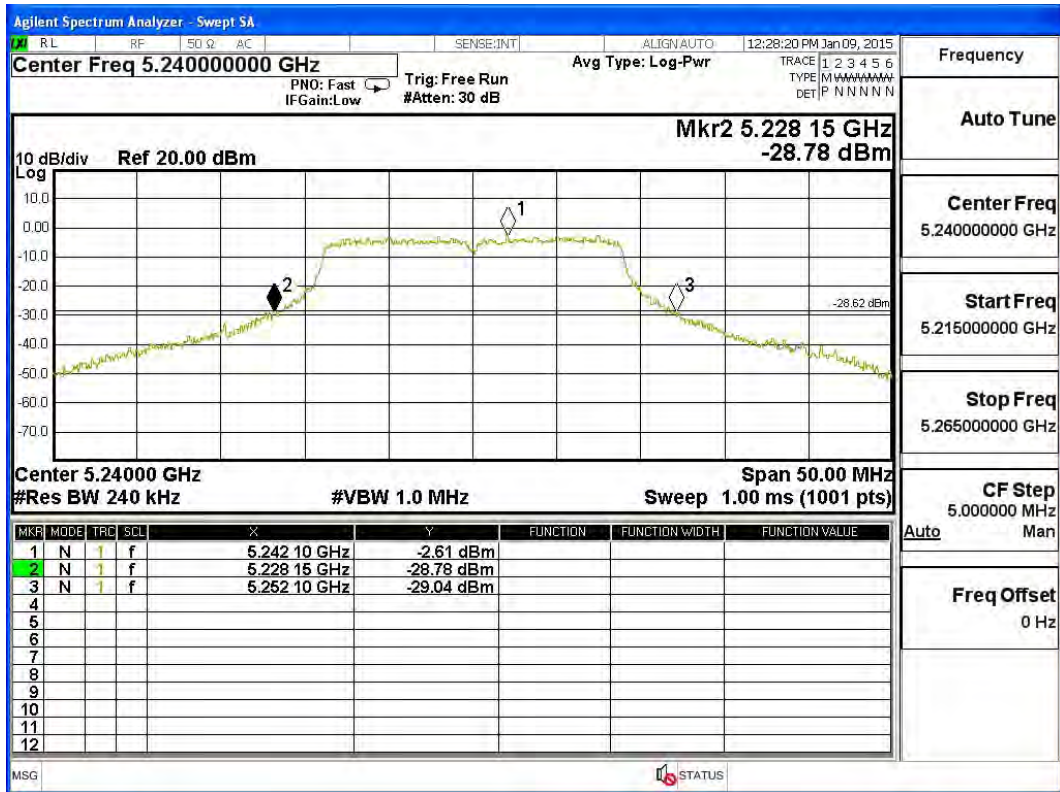

Channel 52 -Chain B

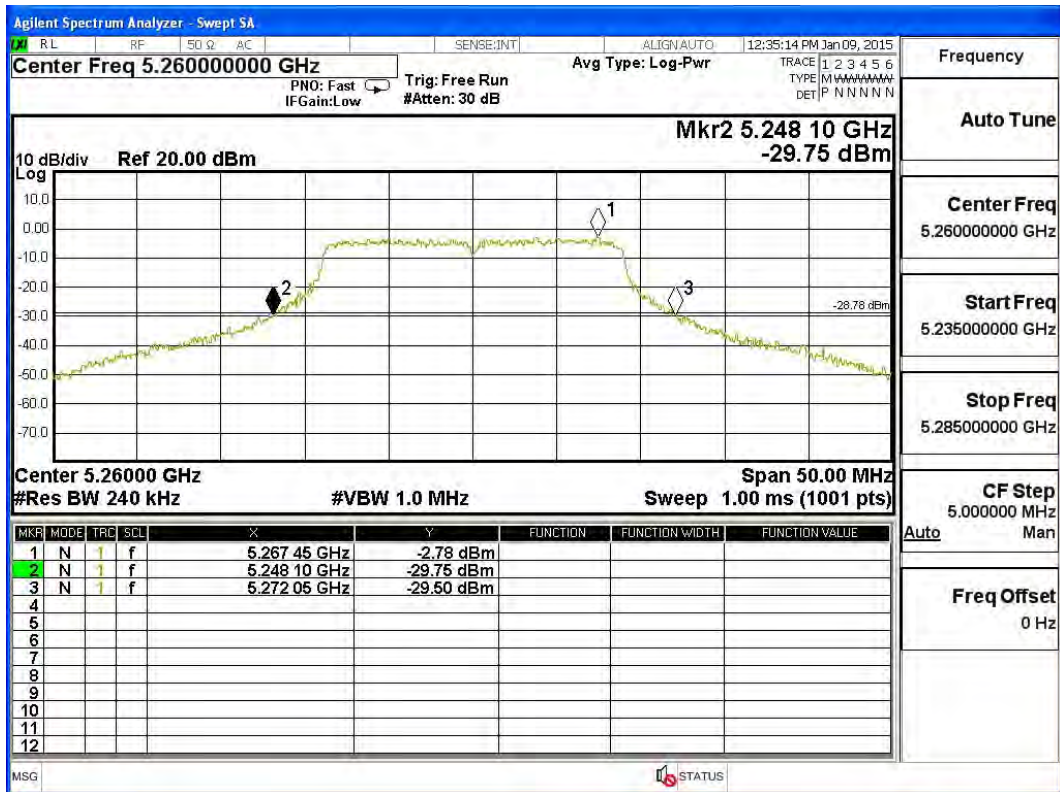

Channel 60 -Chain B

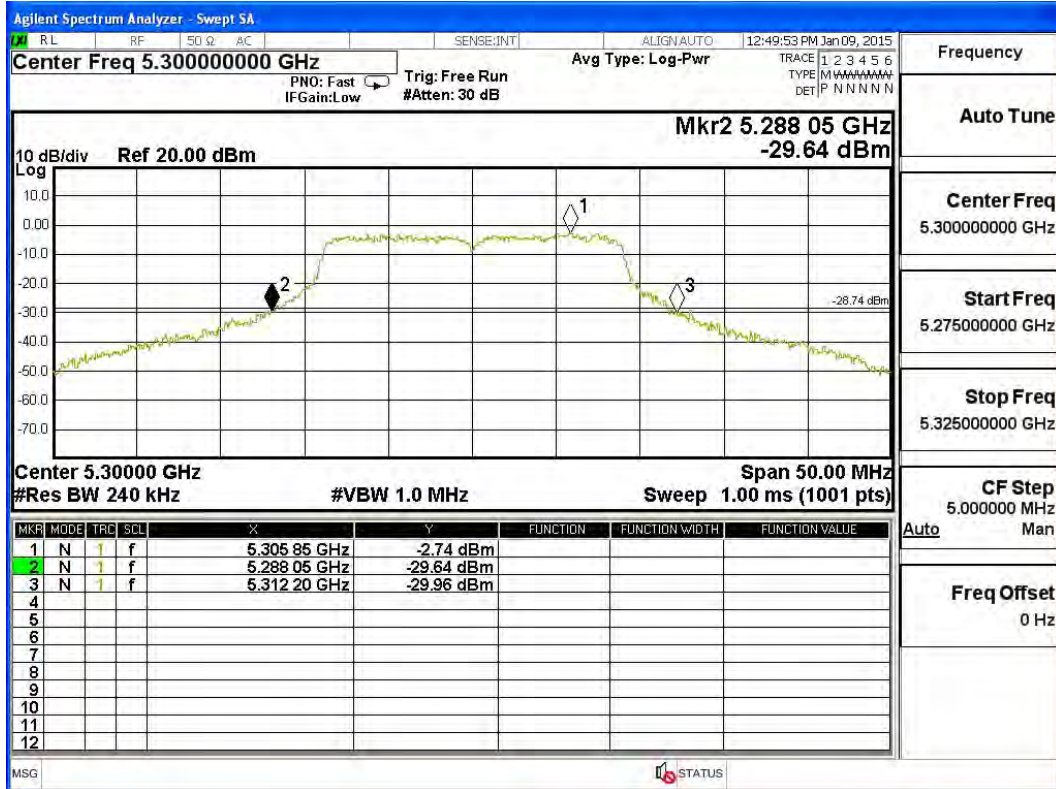

Channel 64 -Chain B

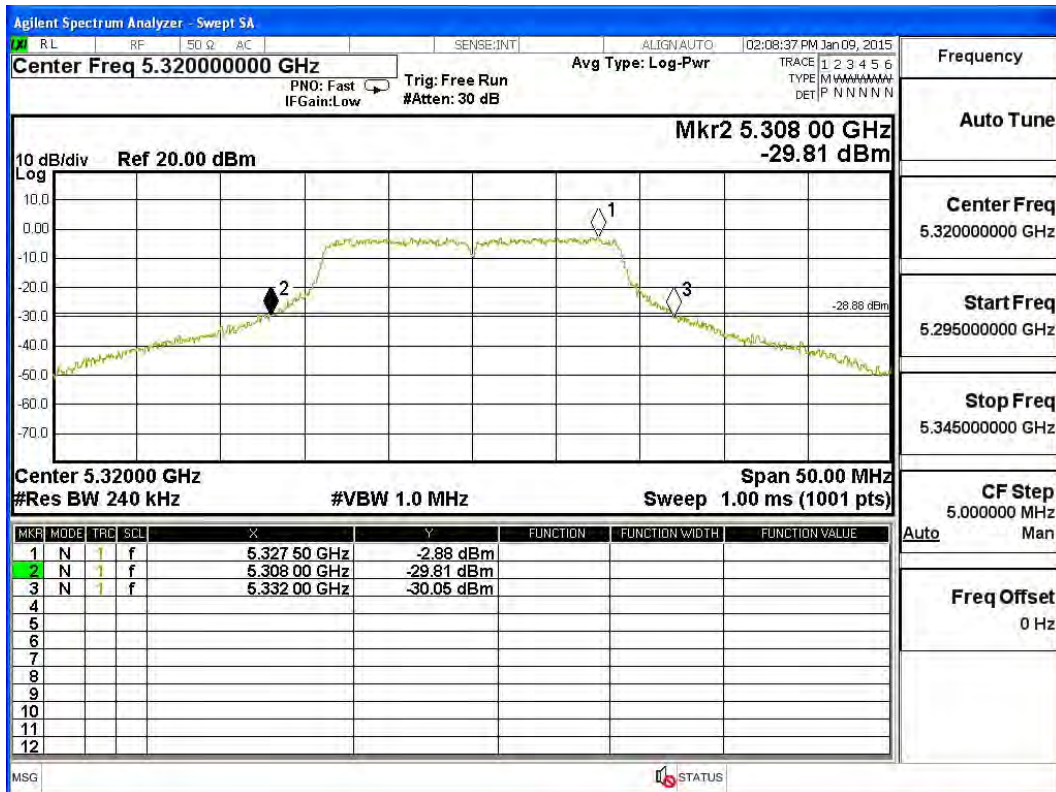

Channel 100 -Chain B

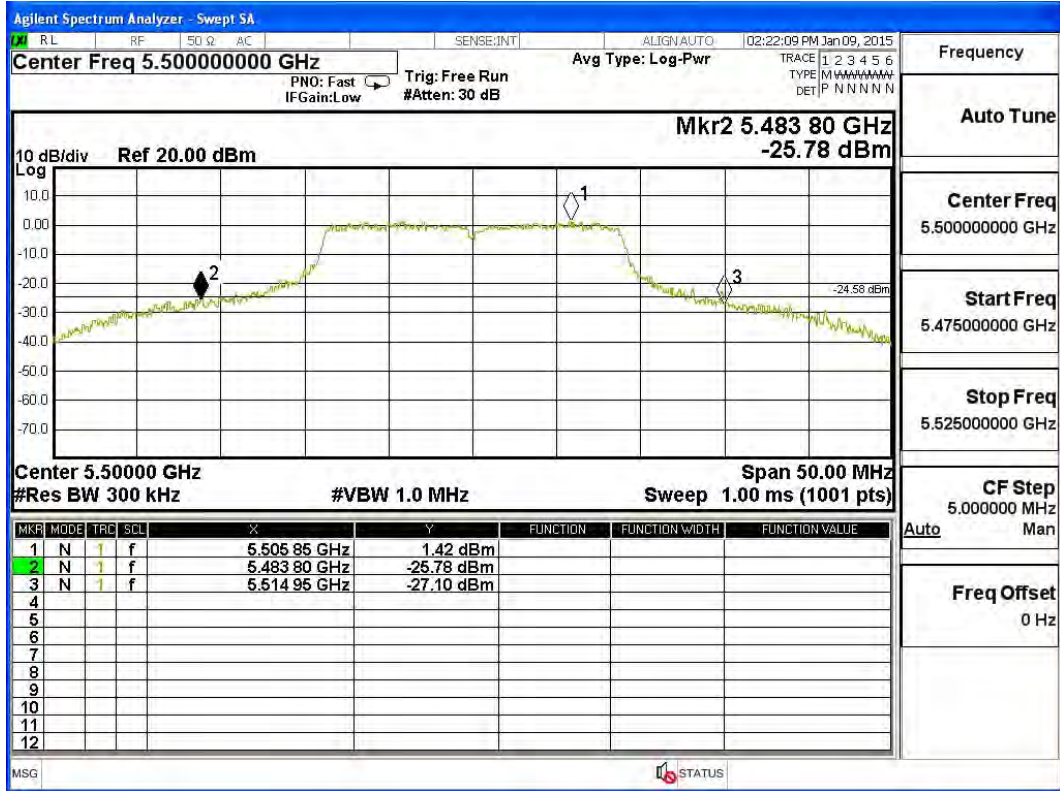

Channel 116 -Chain B

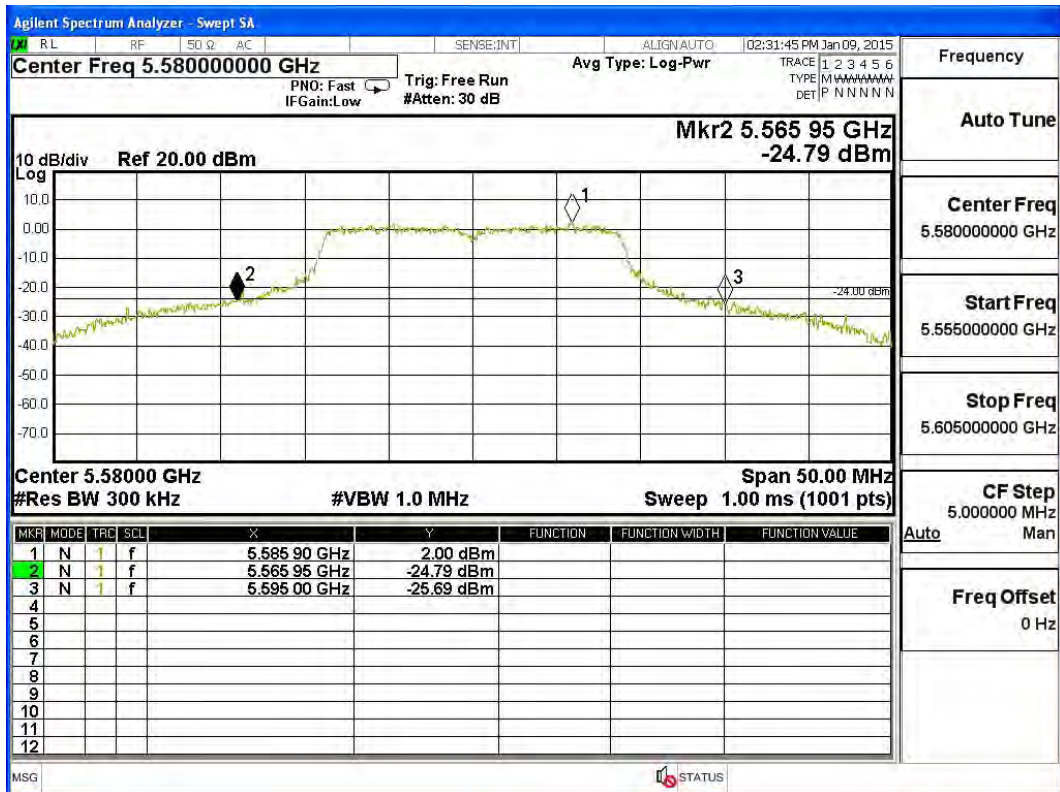

Channel 140 -Chain B

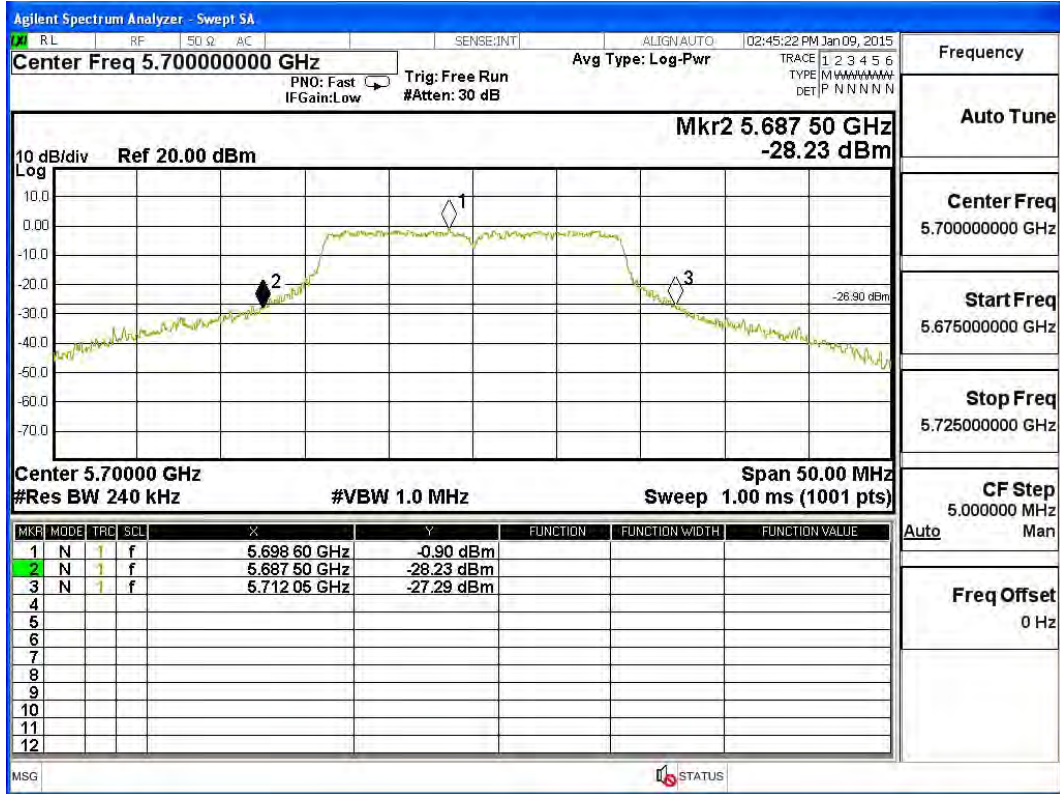

Product : Wireless Access Point
 Test Item : Maximum conducted output power
 Test Site : No.3 OATS
 Test Mode : Mode 3: Transmit (802.11n-40BW 30Mbps) (Internal Antenna)

CHAIN A

Cable loss=1dB		Maximum conducted output power								
Channel No.	Frequency (MHz)	Data Rate (Mbps)								Required Limit
		30	60	90	120	180	240	270	300	
		Measurement Level (dBm)								
38	5190	8.31	--	--	--	--	--	--	--	<17dBm
46	5230	9.92	9.83	9.72	9.65	9.54	9.47	9.37	9.25	<17dBm

Note: Maximum conducted output power Value =Reading value on average power meter + cable loss

CHAIN B

Cable loss=1dB		Maximum conducted output power								
Channel No.	Frequency (MHz)	Data Rate (Mbps)								Required Limit
		30	60	90	120	180	240	270	300	
		Measurement Level (dBm)								
38	5190	7.67	--	--	--	--	--	--	--	<17dBm
46	5230	9.47	9.34	9.2	9.08	8.91	8.82	8.67	8.55	<17dBm

Note: Maximum conducted output power Value =Reading value on average power meter + cable loss

Maximum conducted output power Measurement:

(CHAIN A+ B)

Channel Number	Frequency (MHz)	26dB Bandwidth (MHz)	Chain A Power (dBm)	Chain B Power (dBm)	Output Power (dBm)	Output Power Limit	
						(dBm)	dBm+10log(BW)
38	5190	44.700	8.31	7.67	11.01	17	20.50
46	5230	46.400	9.92	9.47	12.71	17	20.67

Note:

1. Power Output Value =Reading value on average power meter + cable loss
2. Output Power (dBm) = 10LOG (Chain A Power (mW)+ Chain B Power (mW))
3. 26 dB Bandwidth is the bandwidth of chain A or chain B whichever is less bandwidth, output power limitation is more stringent.

26dBc Occupied Bandwidth:
Channel 38 – Chain A

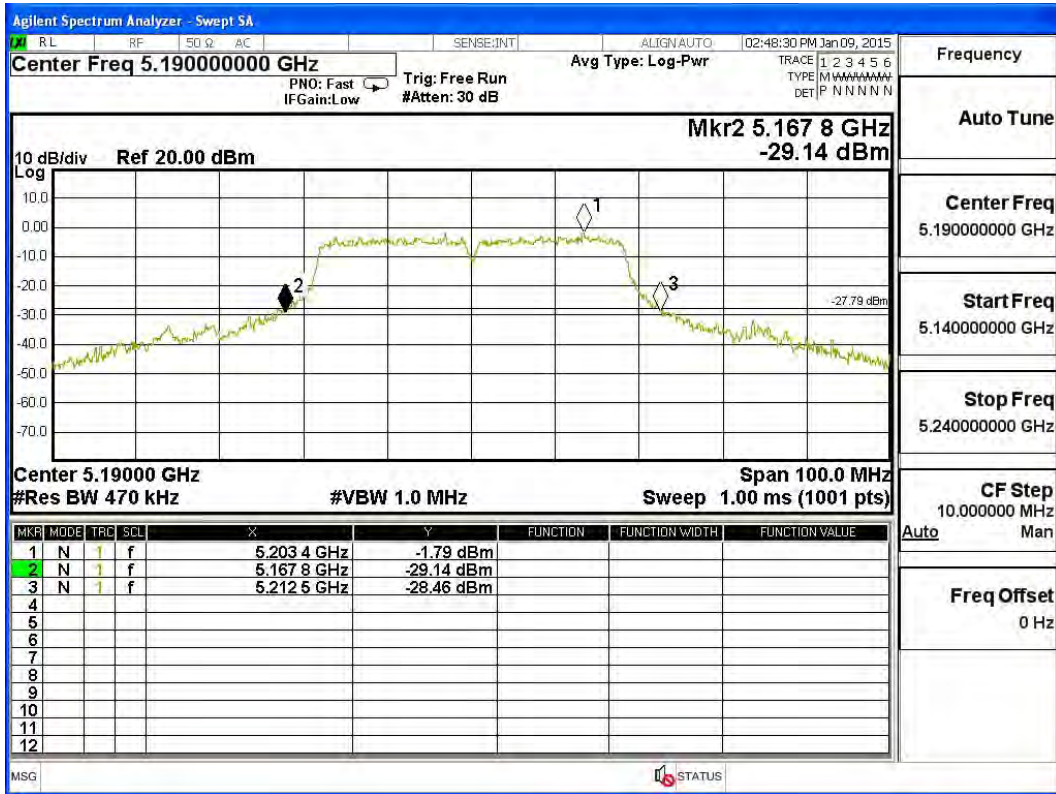

Channel 46 – Chain A

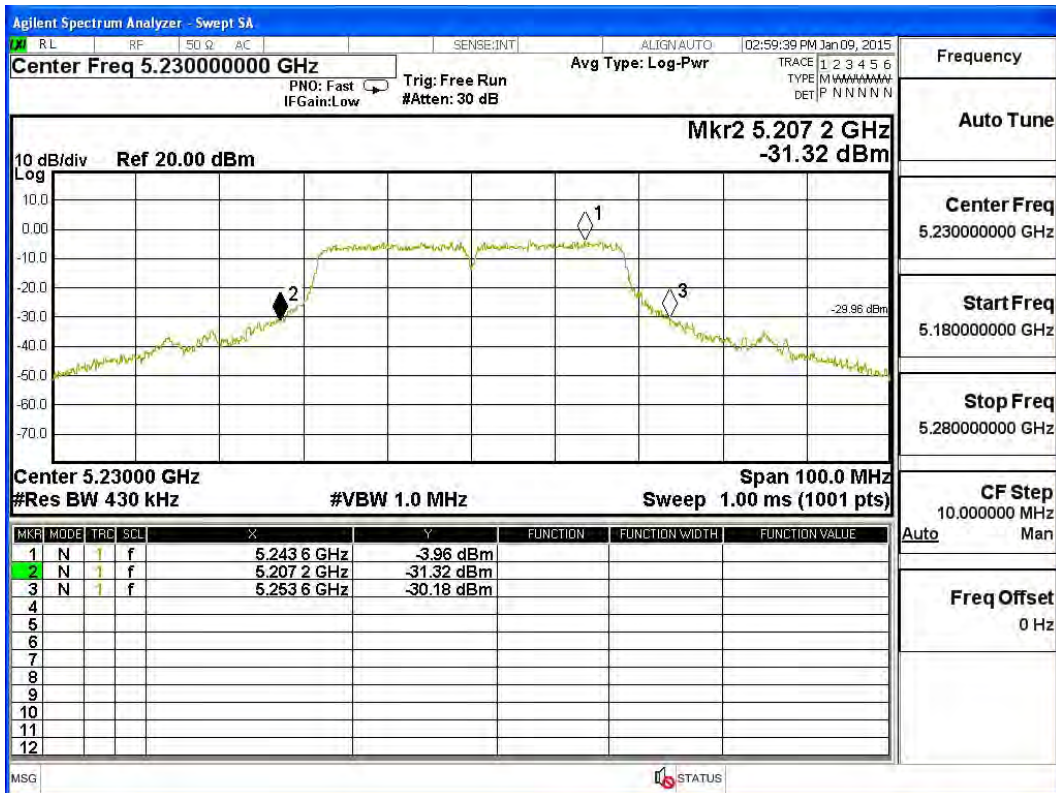

26dBc Occupied Bandwidth:
Channel 38 – Chain B

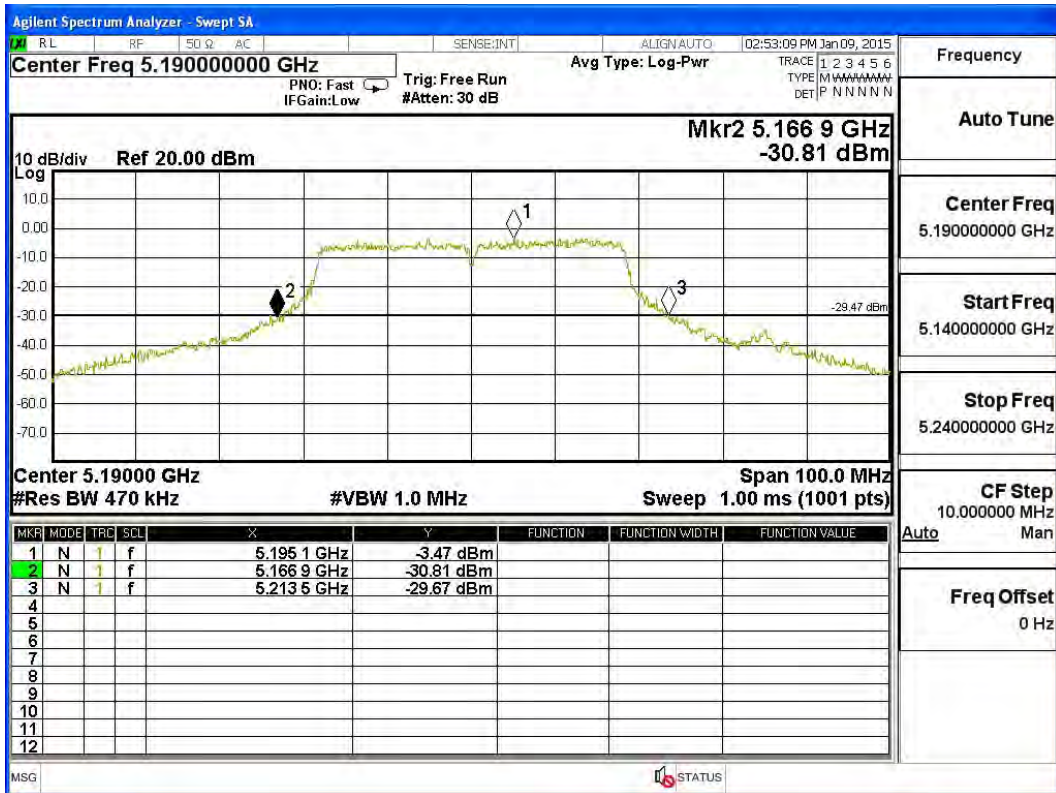

Channel 46 – Chain B

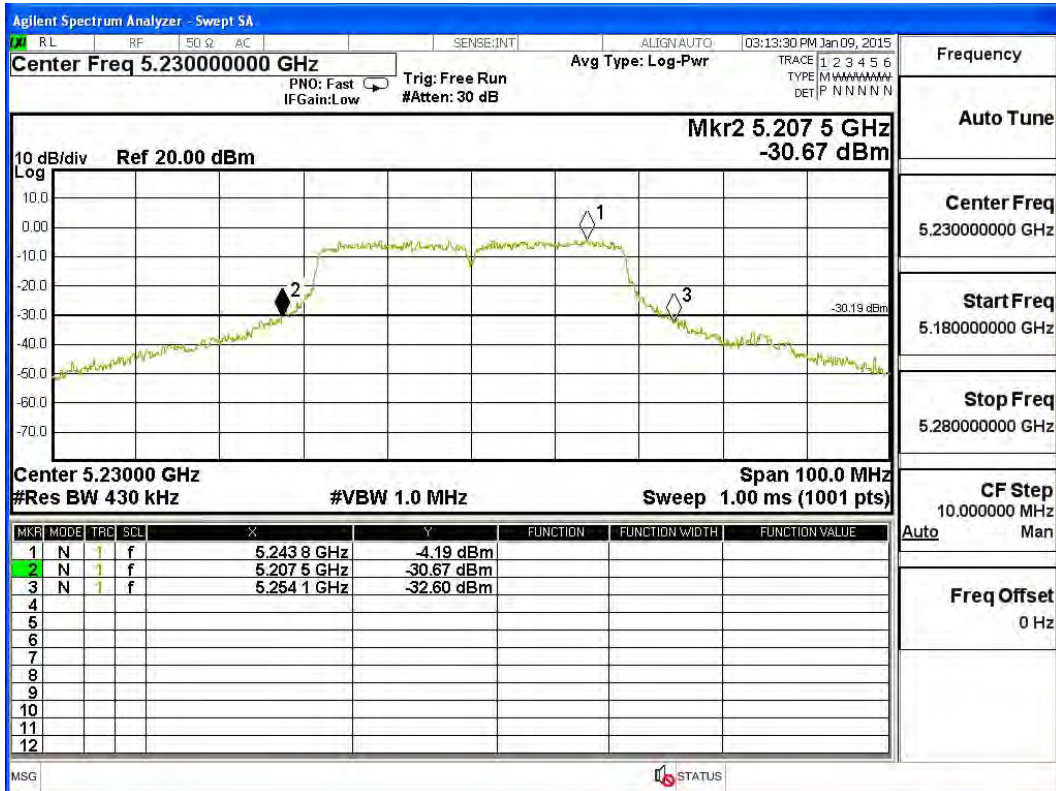

Product : Wireless Access Point
 Test Item : Maximum conducted output power
 Test Site : No.3 OATS
 Test Mode : Mode 1: Transmit (802.11a-6Mbps) (External Antenna)

CHAIN A

Cable loss=1dB		Maximum conducted output power								
Channel No.	Frequency (MHz)	Data Rate (Mbps)								Required Limit
		6	9	12	18	24	36	48	54	
		Measurement Level (dBm)								
36	5180	10.24	--	--	--	--	--	--	--	<17dBm
44	5220	10.28	10.21	10.18	10.07	10.01	9.91	9.86	9.79	<17dBm
48	5240	10.2	--	--	--	--	--	--	--	<17dBm
52	5260	10.13	--	--	--	--	--	--	--	<24dBm
60	5300	9.75	9.61	9.46	9.38	9.19	9.08	8.91	8.84	<24dBm
64	5320	9.53	--	--	--	--	--	--	--	<24dBm
100	5500	11.22	--	--	--	--	--	--	--	<24dBm
116	5580	11.47	11.34	11.26	11.18	10.96	10.82	10.71	10.66	<24dBm
140	5700	8.41	--	--	--	--	--	--	--	<24dBm

Note: Maximum conducted output power Value =Reading value on average power meter + cable loss

CHAIN B

Cable loss=1dB		Maximum conducted output power								
Channel No.	Frequency (MHz)	Data Rate (Mbps)								Required Limit
		6	9	12	18	24	36	48	54	
		Measurement Level (dBm)								
36	5180	10.11	--	--	--	--	--	--	--	<17dBm
44	5220	10.15	10.05	10.01	9.94	9.81	9.77	9.62	9.55	<17dBm
48	5240	10.1	--	--	--	--	--	--	--	<17dBm
52	5260	10.06	--	--	--	--	--	--	--	<24dBm
60	5300	9.66	9.52	9.44	9.31	9.15	9.02	8.81	8.77	<24dBm
64	5320	9.47	--	--	--	--	--	--	--	<24dBm
100	5500	11.09	--	--	--	--	--	--	--	<24dBm
116	5580	11.34	11.25	11.16	11.05	10.94	10.72	10.64	10.54	<24dBm
140	5700	8.32	--	--	--	--	--	--	--	<24dBm

Note: Maximum conducted output power Value =Reading value on average power meter + cable loss

Maximum conducted output power Measurement:

Channel No	Frequency Range (MHz)	26dB Bandwidth (MHz)	Output Power (dBm)	Output Power Limit	
				(dBm)	dBm+10log(BW)
36	5180	22.000	10.24	17	17.42
44	5220	21.900	10.28	17	17.40
48	5240	21.800	10.2	17	17.38
52	5260	22.950	10.13	24	24.61
60	5300	22.750	9.75	24	24.57
64	5320	22.150	9.53	24	24.45
100	5500	22.300	11.22	24	24.48
116	5580	21.850	11.47	24	24.39
140	5700	22.400	8.41	24	24.50

Note:

3. Power Output Value =Reading value on average power meter + cable loss
4. 26 dB Bandwidth is the bandwidth of chain A or chain B whichever is less bandwidth, output power limitation is more stringent.

26dBc Occupied Bandwidth:
Channel 36:

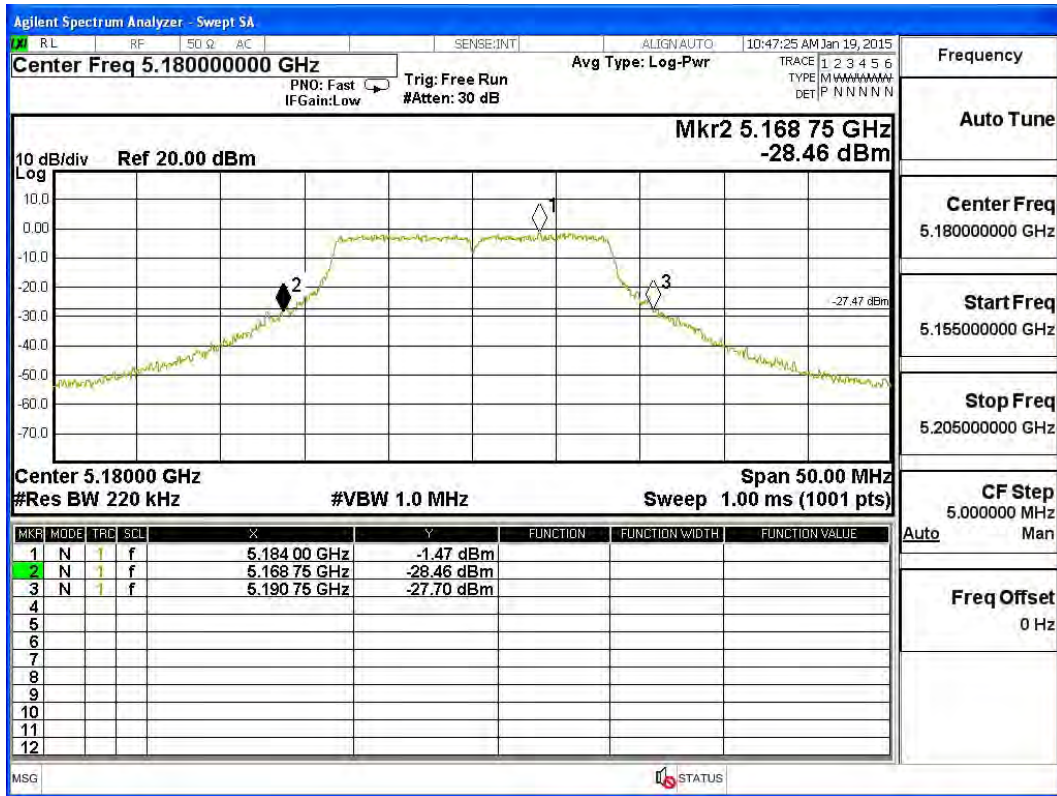

Channel 44:

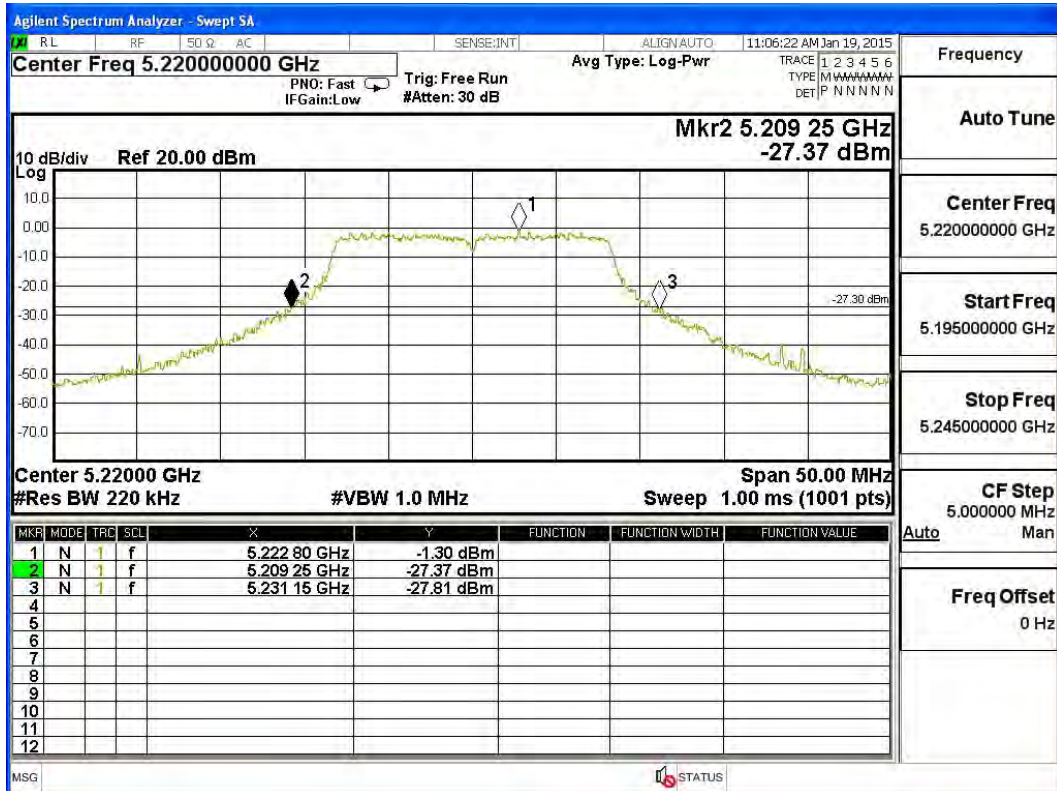

Channel 48:

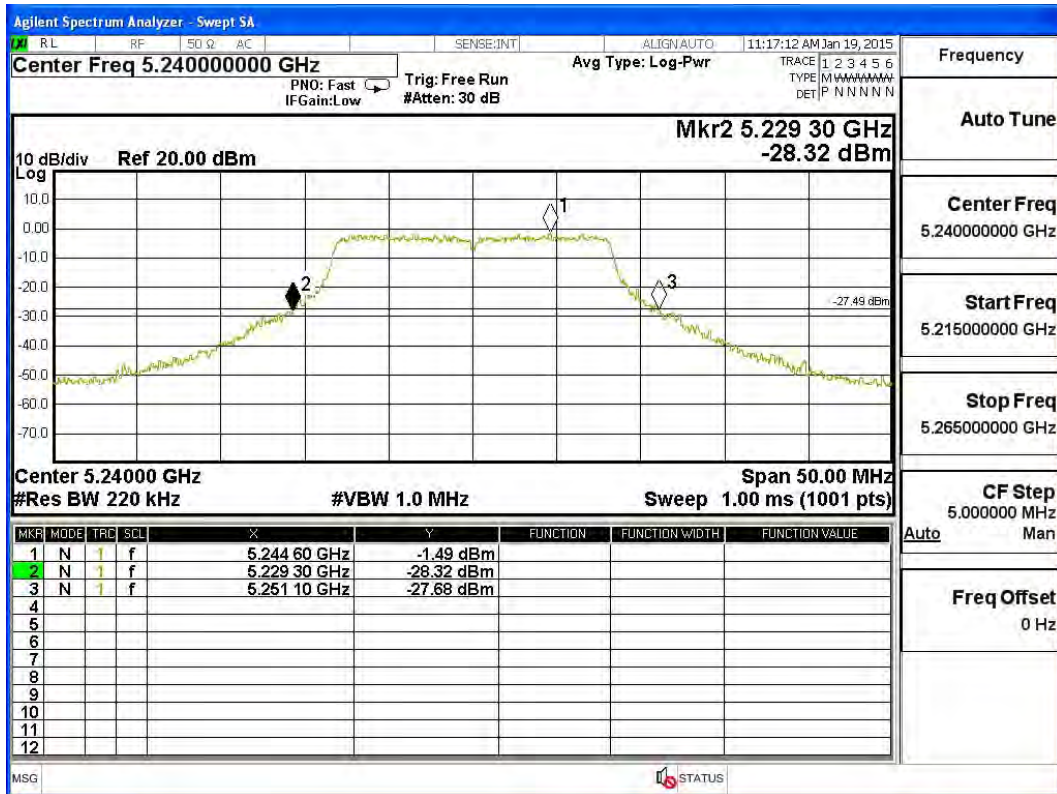

Channel 52:

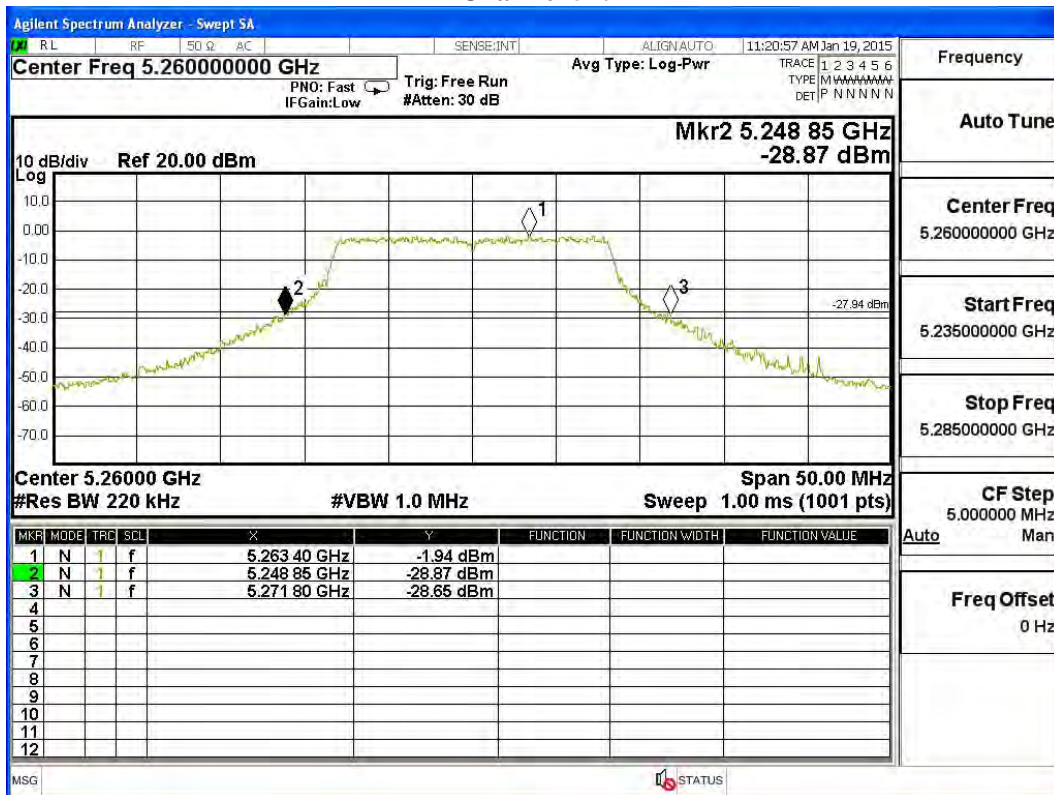

Channel 60:

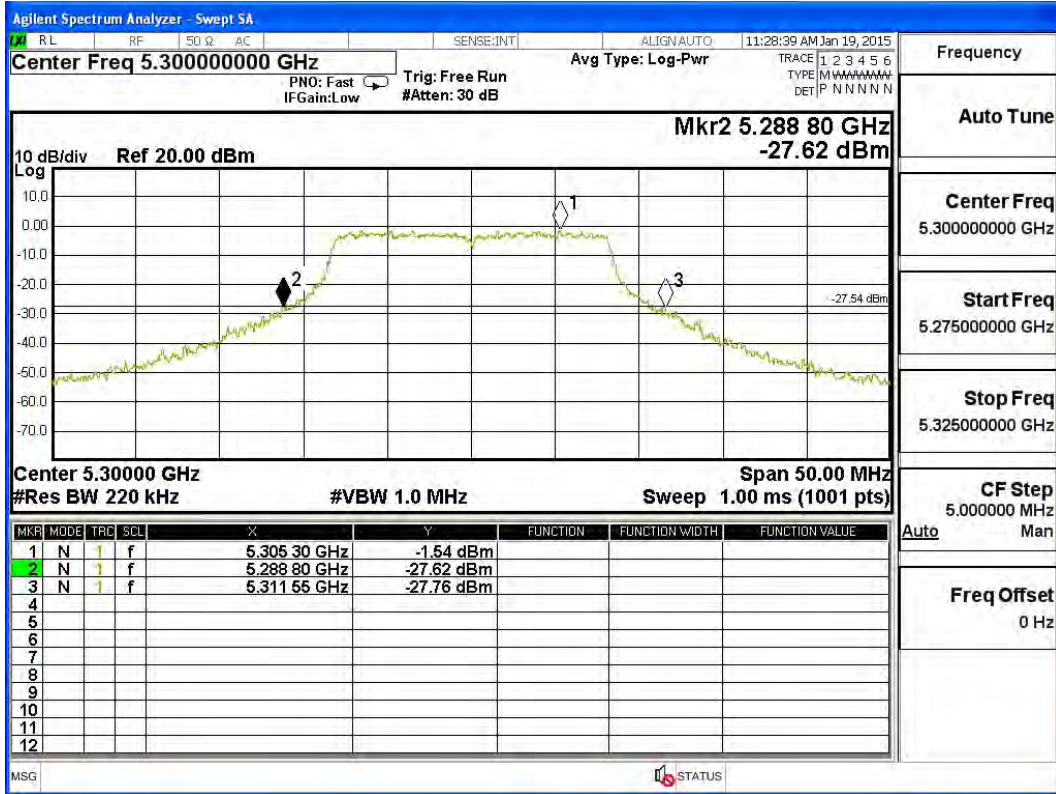

Channel 64:

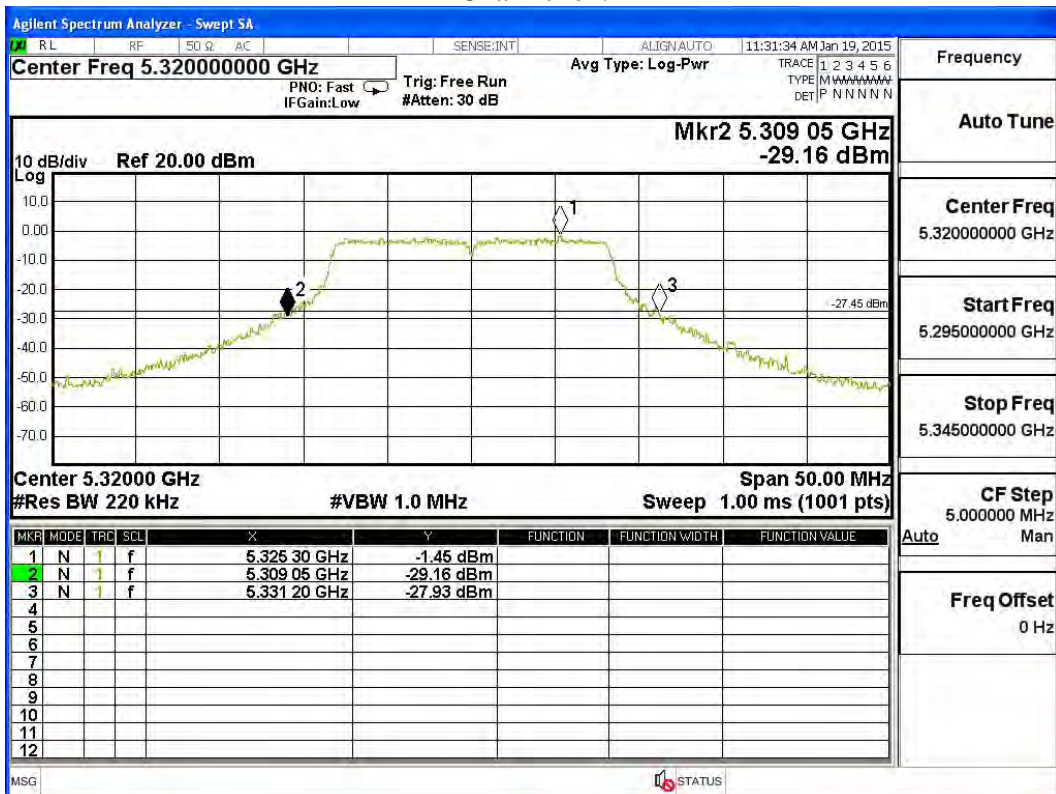

Channel 100:

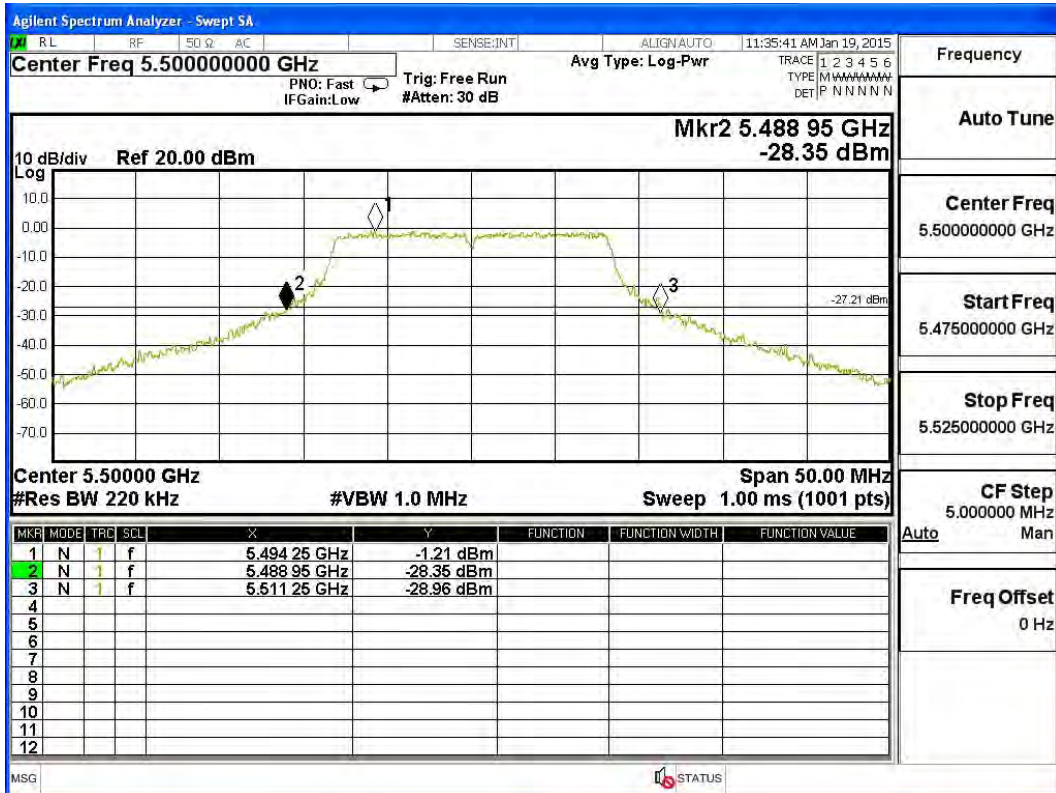

Channel 116:

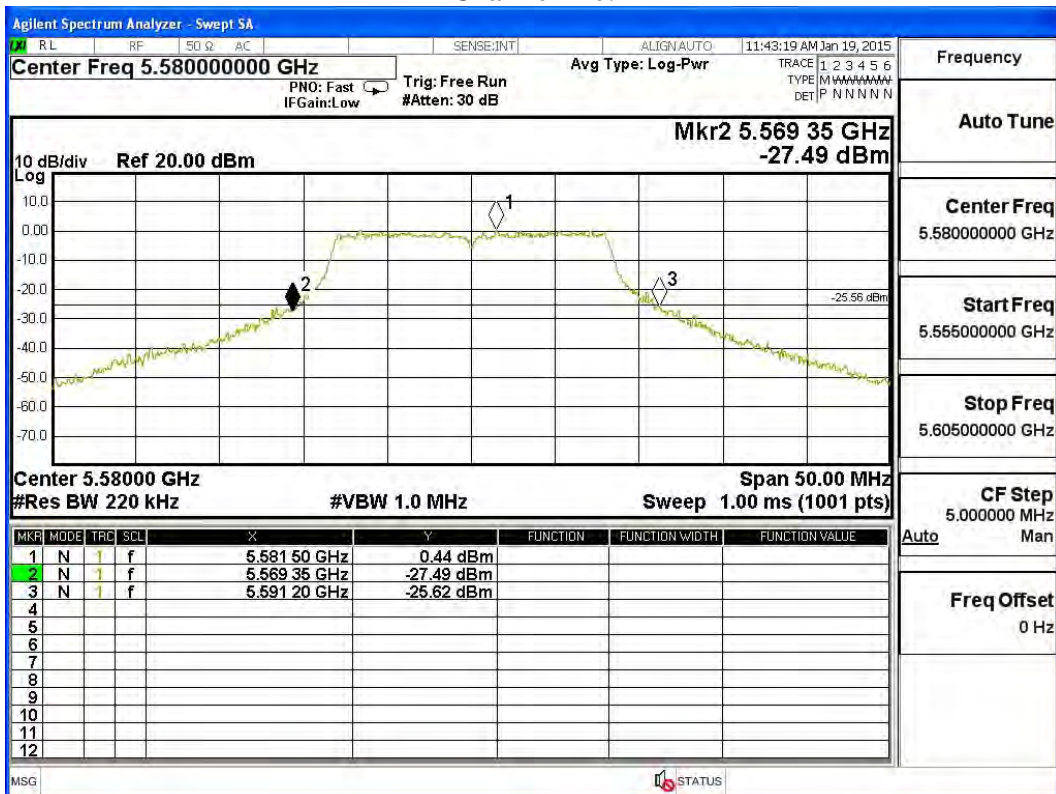

Channel 140:

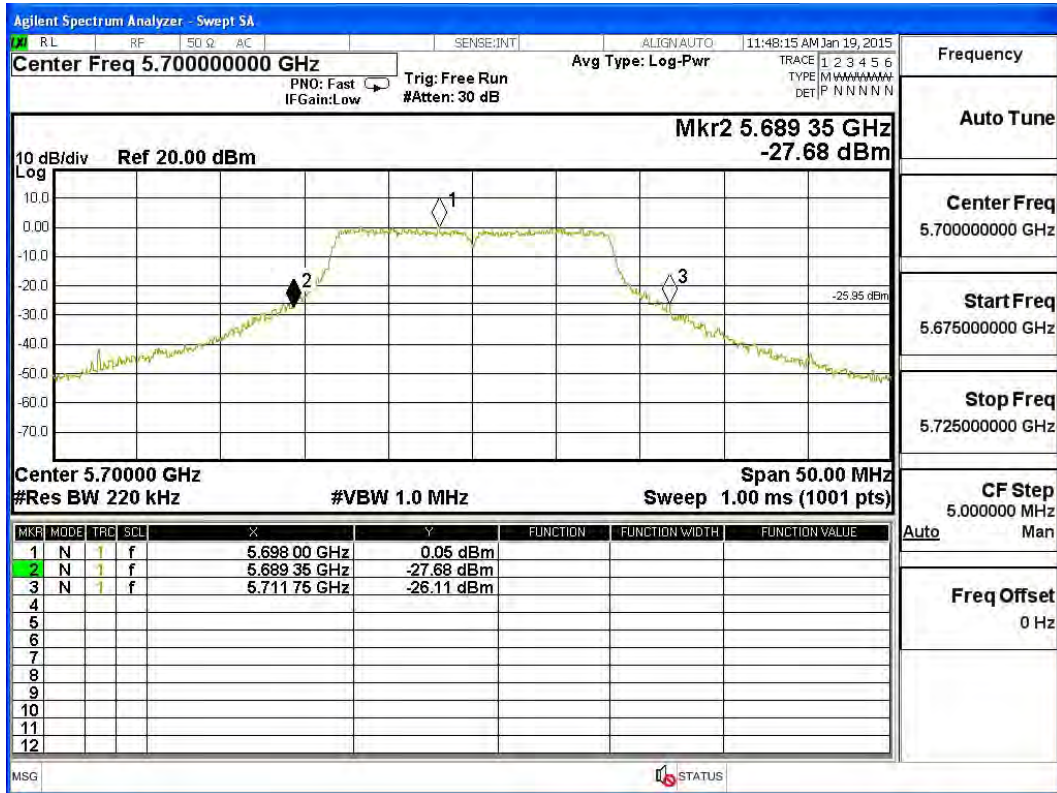

Product : Wireless Access Point
 Test Item : Maximum conducted output power
 Test Site : No.3 OATS
 Test Mode : Mode 2: Transmit (802.11n-20BW 14.4Mbps) (External Antenna)

CHAIN A

Cable loss=1dB		Maximum conducted output power								
Channel No.	Frequency (MHz)	Data Rate (Mbps)								Required Limit
		14.4	28.9	43.3	57.8	86.7	115.6	130	144.4	
		Measurement Level (dBm)								
36	5180	10.13	--	--	--	--	--	--	--	<17dBm
44	5220	10.12	10.04	9.95	9.88	9.82	9.71	9.64	9.58	<17dBm
48	5240	10.13	--	--	--	--	--	--	--	<17dBm
52	5260	9.94	--	--	--	--	--	--	--	<24dBm
60	5300	9.57	9.51	9.46	9.39	9.32	9.27	9.24	9.15	<24dBm
64	5320	9.31	--	--	--	--	--	--	--	<24dBm
100	5500	11.82	--	--	--	--	--	--	--	<24dBm
116	5580	12	11.94	11.88	11.85	11.76	11.68	11.64	11.51	<24dBm
140	5700	9.08	--	--	--	--	--	--	--	<24dBm

Note: Maximum conducted output power Value =Reading value on average power meter + cable loss

CHAIN B

Cable loss=1dB		Maximum conducted output power								
Channel No.	Frequency (MHz)	Data Rate (Mbps)								Required Limit
		14.4	28.9	43.3	57.8	86.7	115.6	130	144.4	
		Measurement Level (dBm)								
36	5180	9.11	--	--	--	--	--	--	--	<17dBm
44	5220	9.31	9.22	9.14	9.08	8.95	8.81	8.77	8.65	<17dBm
48	5240	9.25	--	--	--	--	--	--	--	<17dBm
52	5260	9.57	--	--	--	--	--	--	--	<24dBm
60	5300	9.82	9.77	9.72	9.66	9.62	9.55	9.52	9.41	<24dBm
64	5320	9.82	--	--	--	--	--	--	--	<24dBm
100	5500	12.37	--	--	--	--	--	--	--	<24dBm
116	5580	11.96	11.85	11.74	11.63	11.52	11.45	11.3	11.12	<24dBm
140	5700	10.31	--	--	--	--	--	--	--	<24dBm

Note: Maximum conducted output power Value =Reading value on average power meter + cable loss

Maximum conducted output power Measurement:

(CHAIN A+ B)

Channel Number	Frequency (MHz)	26dB Bandwidth (MHz)	Chain A Power (dBm)	Chain B Power (dBm)	Output Power (dBm)	Output Power Limit	
						(dBm)	dBm+10log(BW)
36	5180	22.200	10.13	9.11	12.66	17	17.46
44	5220	23.100	10.12	9.31	12.74	17	17.64
48	5240	22.150	10.13	9.25	12.72	17	17.45
52	5260	22.300	9.94	9.57	12.77	24	24.48
60	5300	22.750	9.57	9.82	12.71	24	24.57
64	5320	22.850	9.31	9.82	12.58	24	24.59
100	5500	22.600	11.82	12.37	15.11	24	24.54
116	5580	22.900	12.00	11.96	14.99	24	24.60
140	5700	23.100	9.08	10.31	12.75	24	24.64

Note:

1. Power Output Value =Reading value on average power meter + cable loss
2. Output Power (dBm) = 10LOG (Chain A Power (mW)+ Chain B Power (mW))
3. 26 dB Bandwidth is the bandwidth of chain A or chain B whichever is less bandwidth, output power limitation is more stringent.

26dBc Occupied Bandwidth:
Channel 36 -Chain A

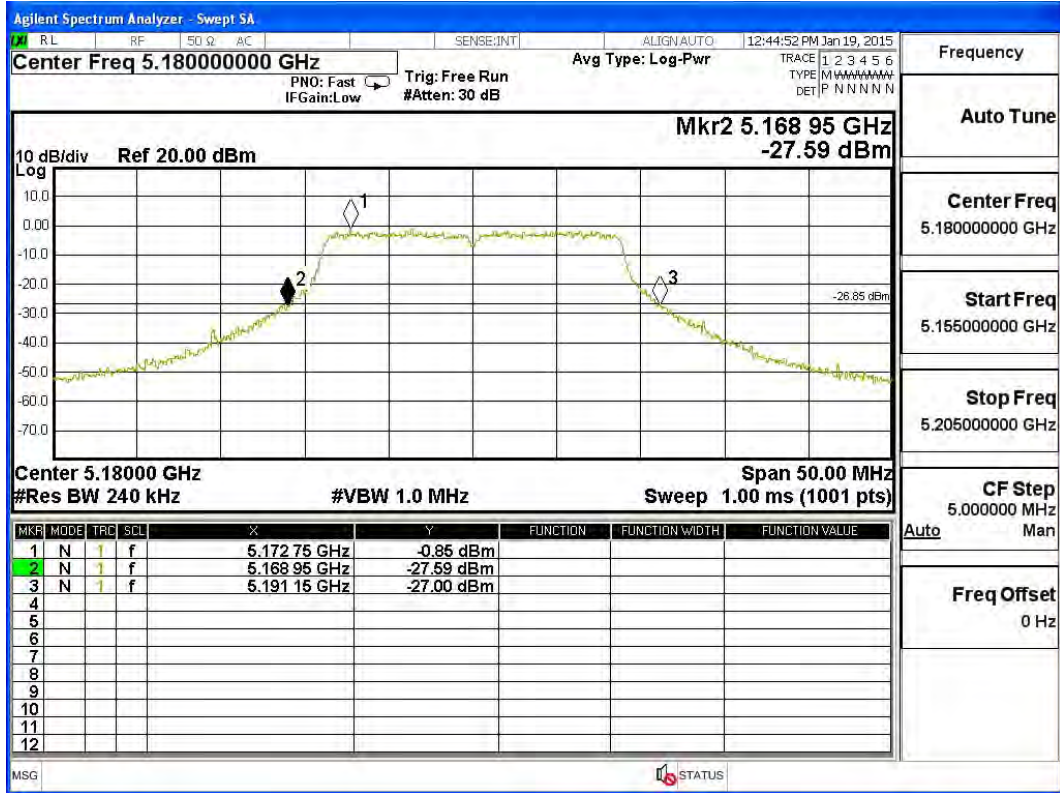

Channel 44 -Chain A

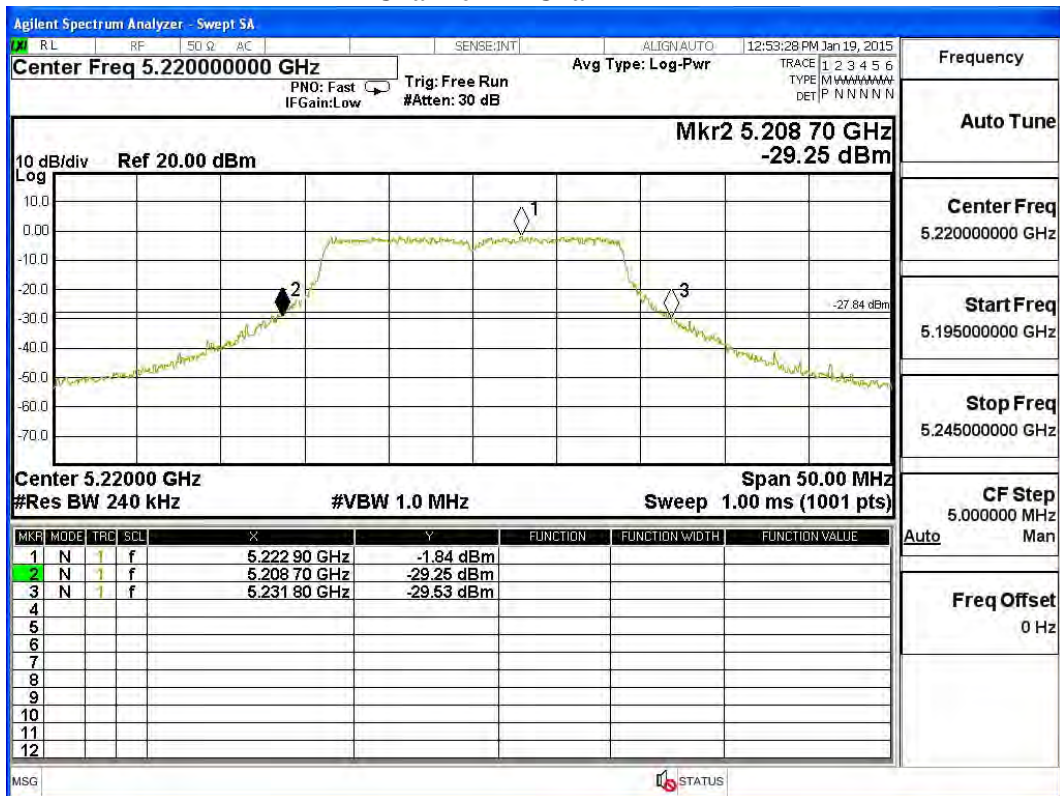

Channel 48 -Chain A

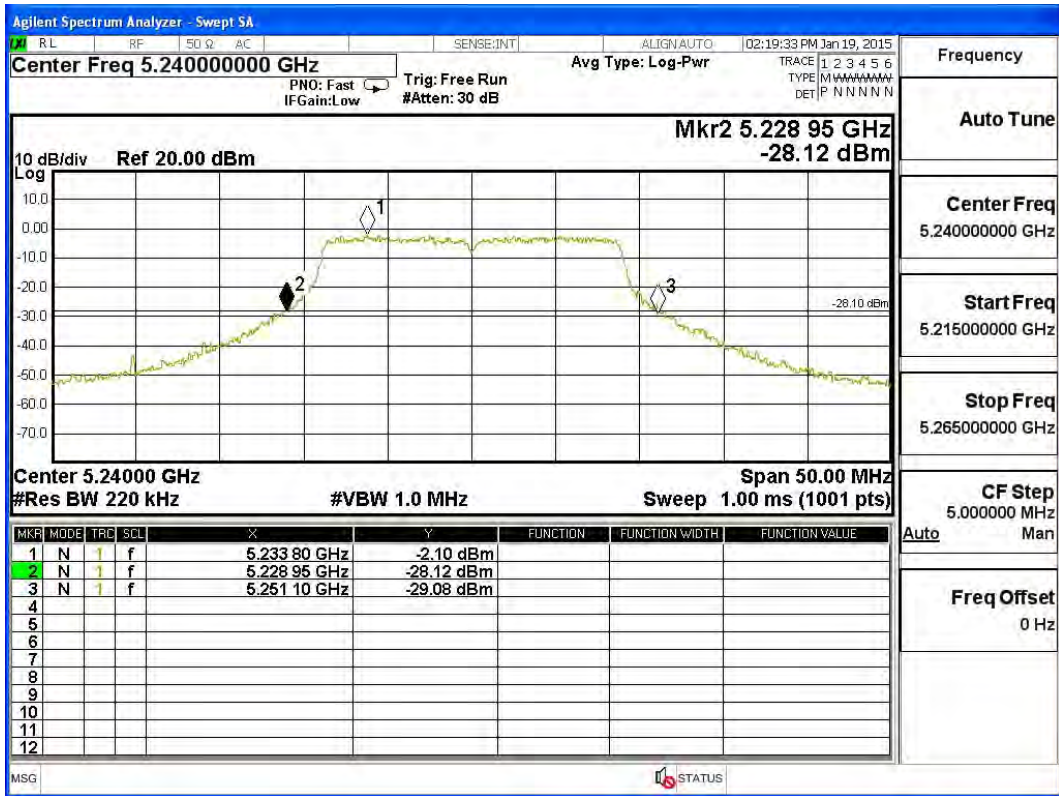

Channel 52 -Chain A

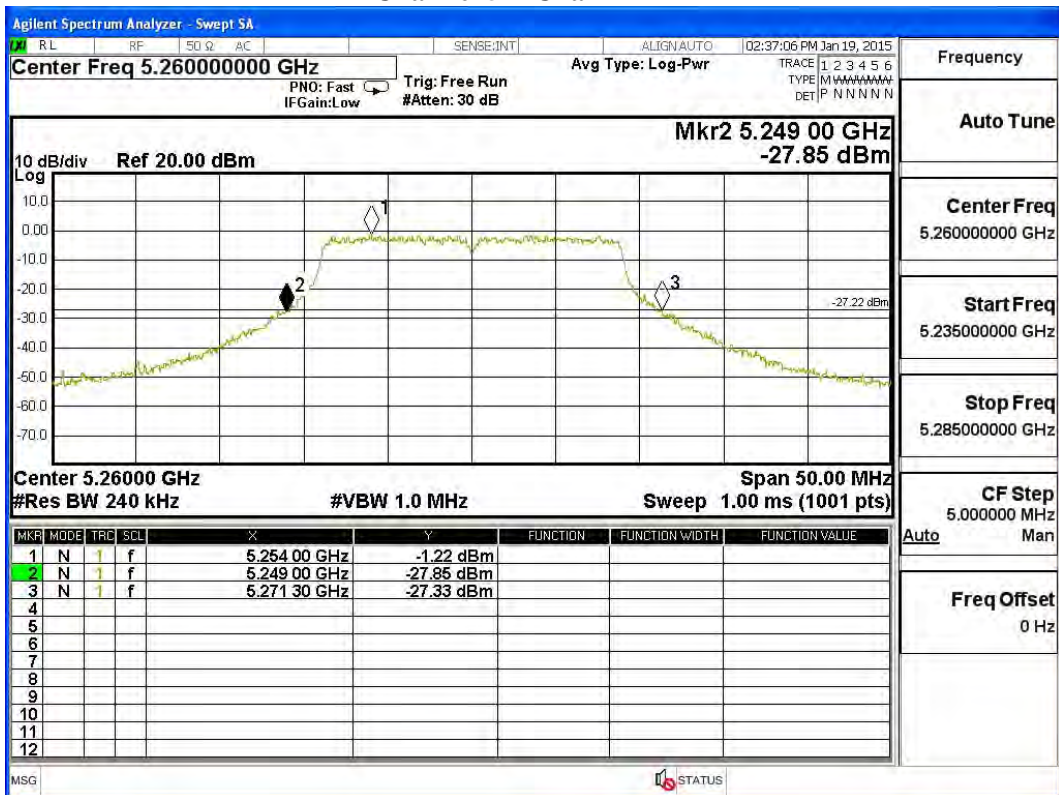

Channel 60 -Chain A

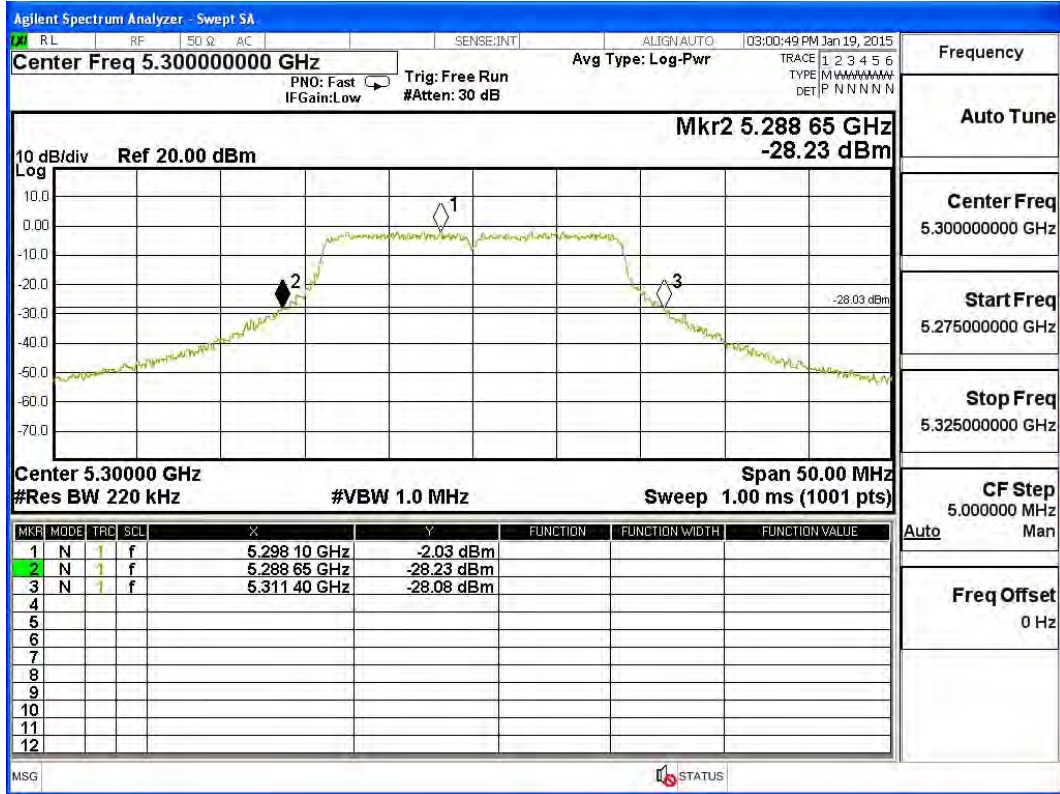

Channel 64 -Chain A

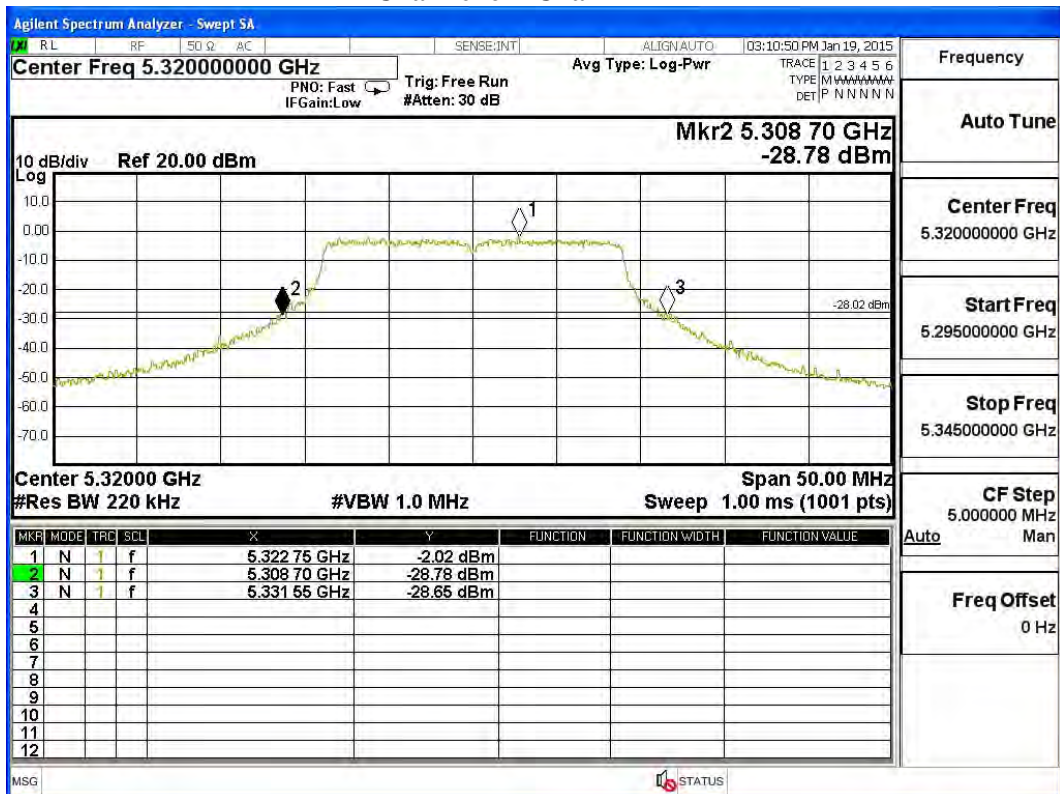

Channel 100 -Chain A

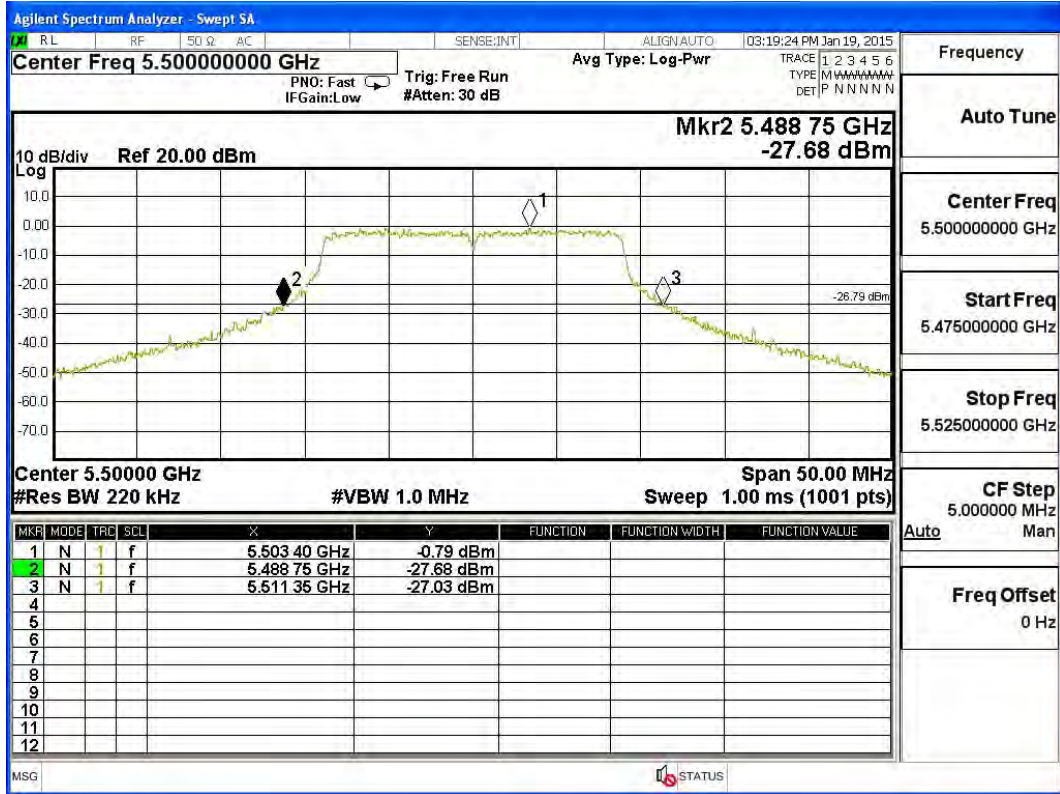

Channel 116 -Chain A

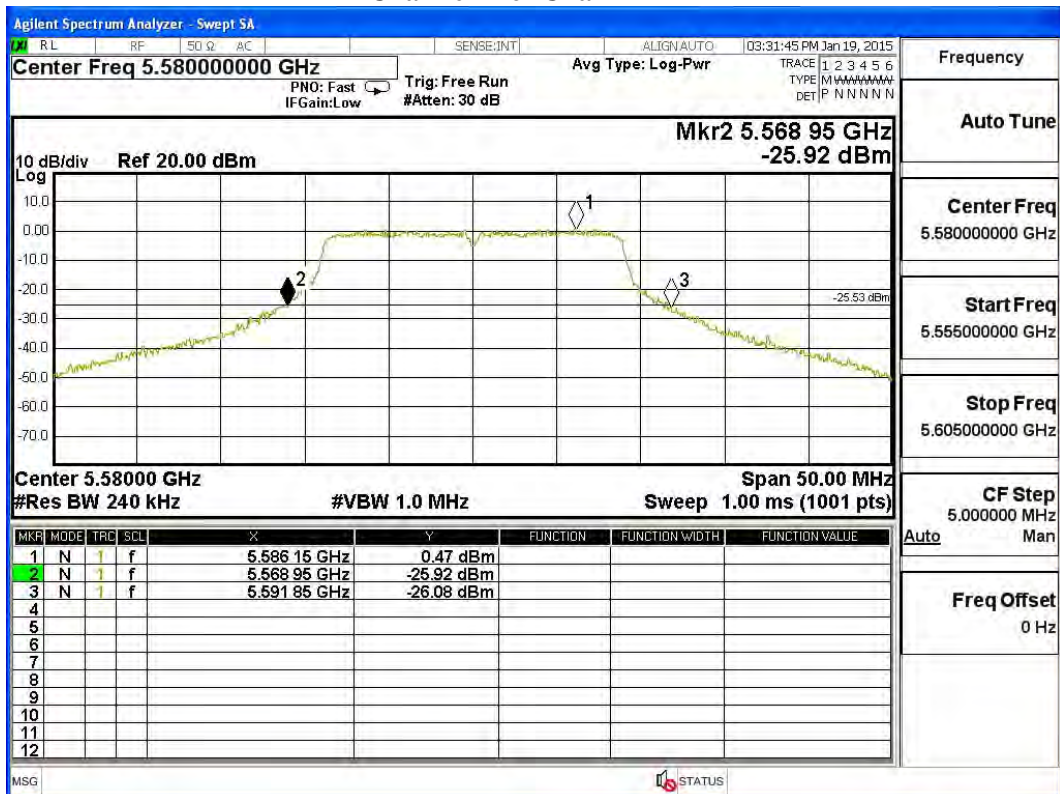

Channel 140 -Chain A

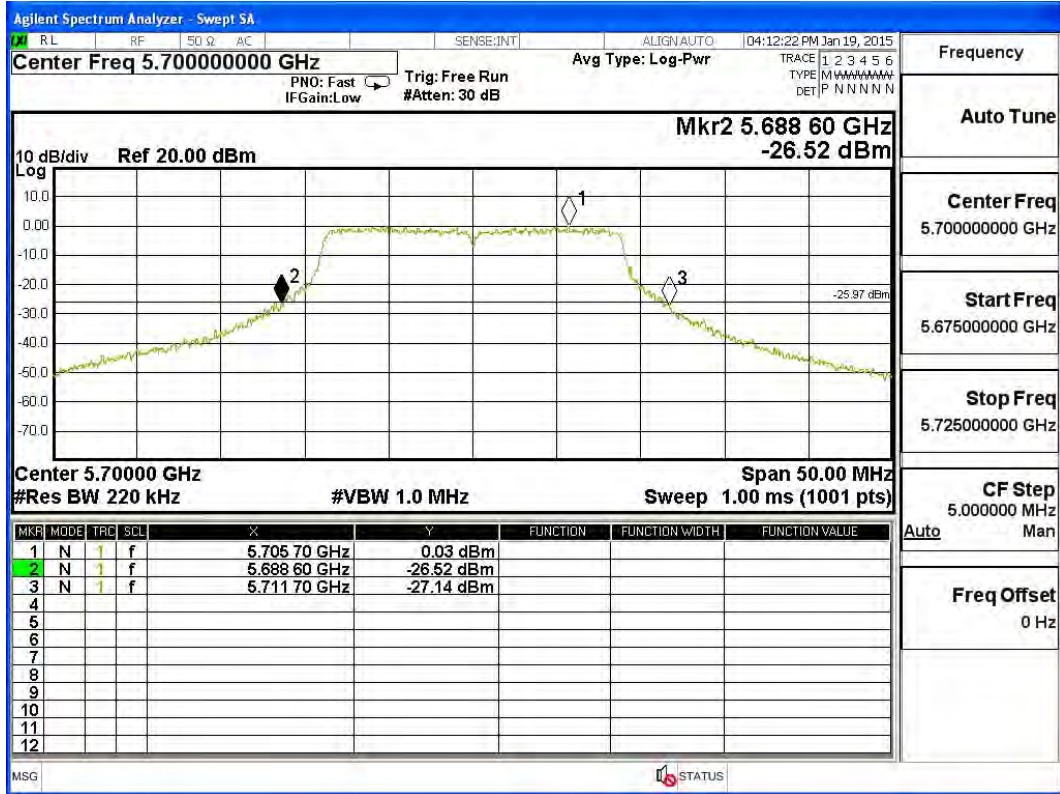

26dBc Occupied Bandwidth:
Channel 36 -Chain B

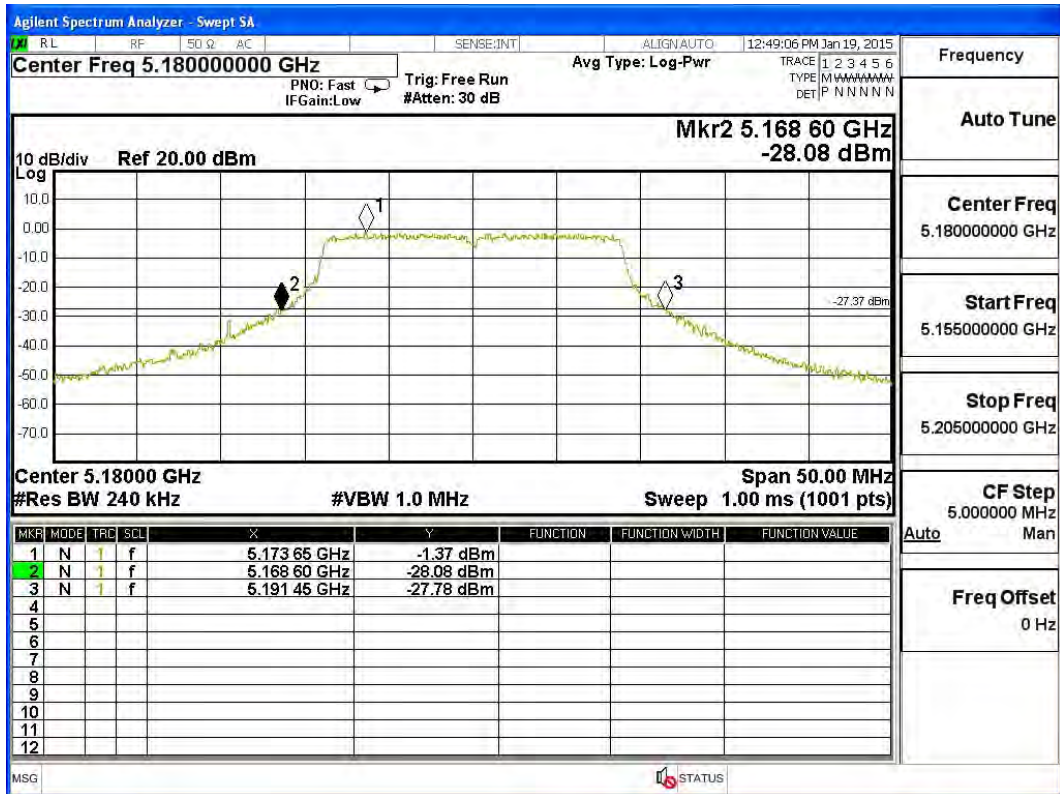

Channel 44 -Chain B

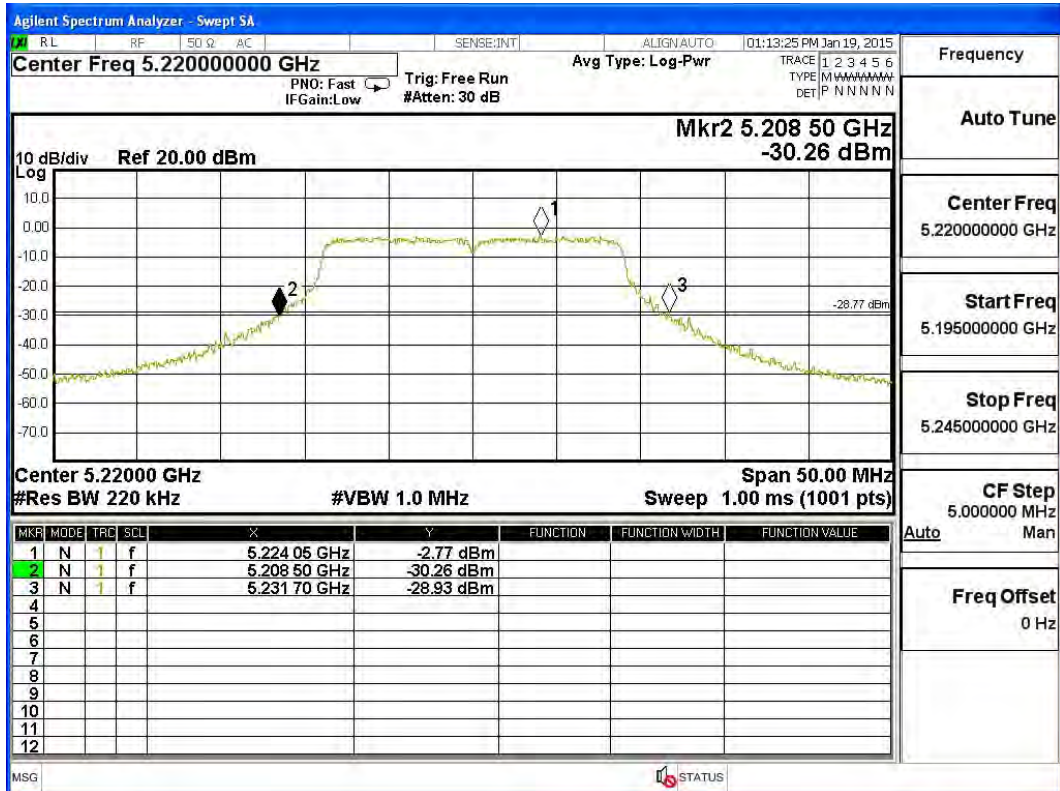

Channel 48 -Chain B

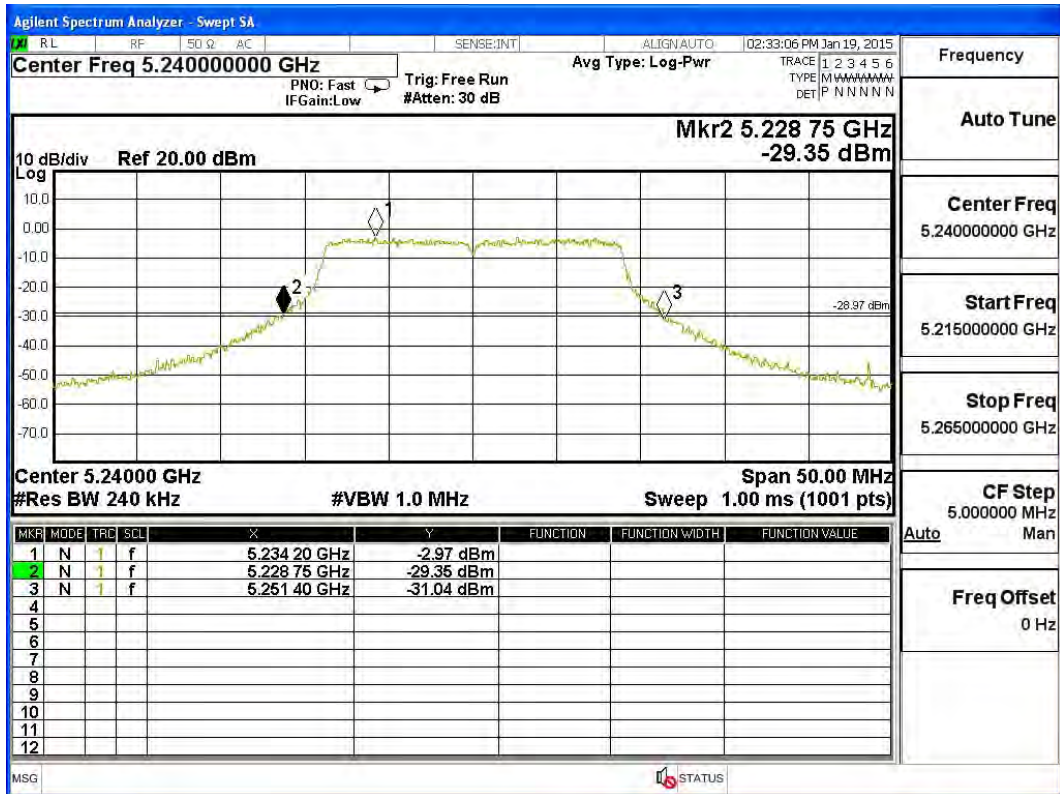

Channel 52 -Chain B

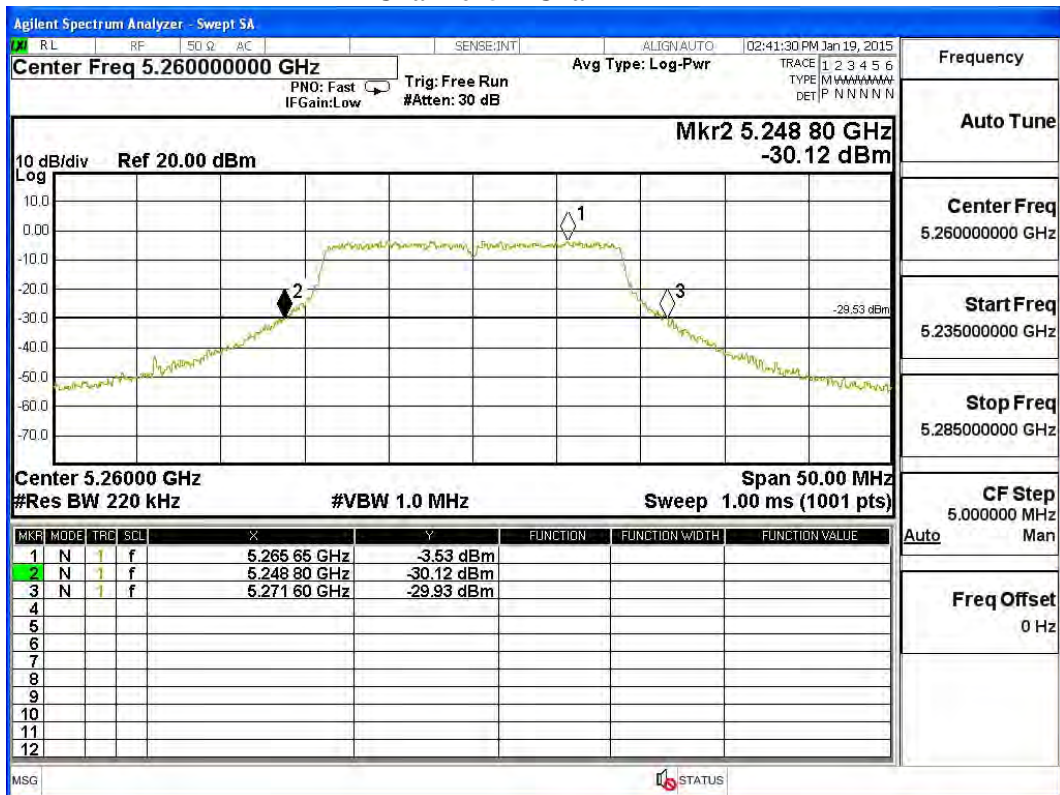

Channel 60 -Chain B

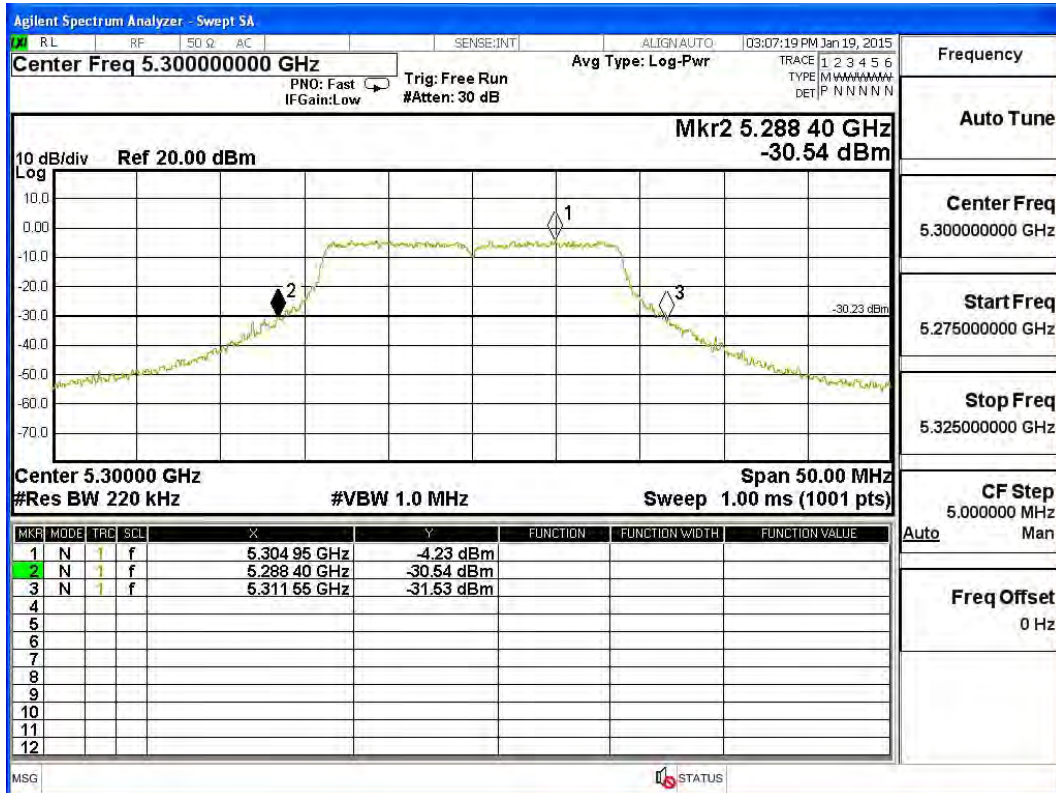

Channel 64 -Chain B

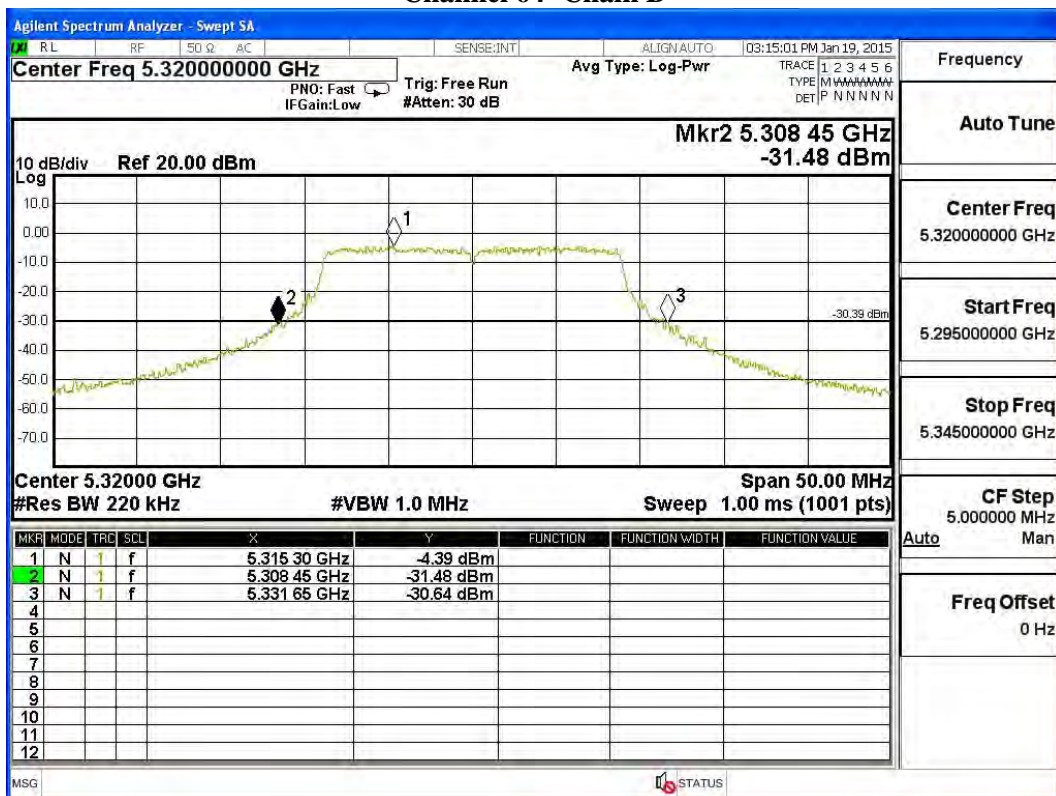

Channel 100 -Chain B

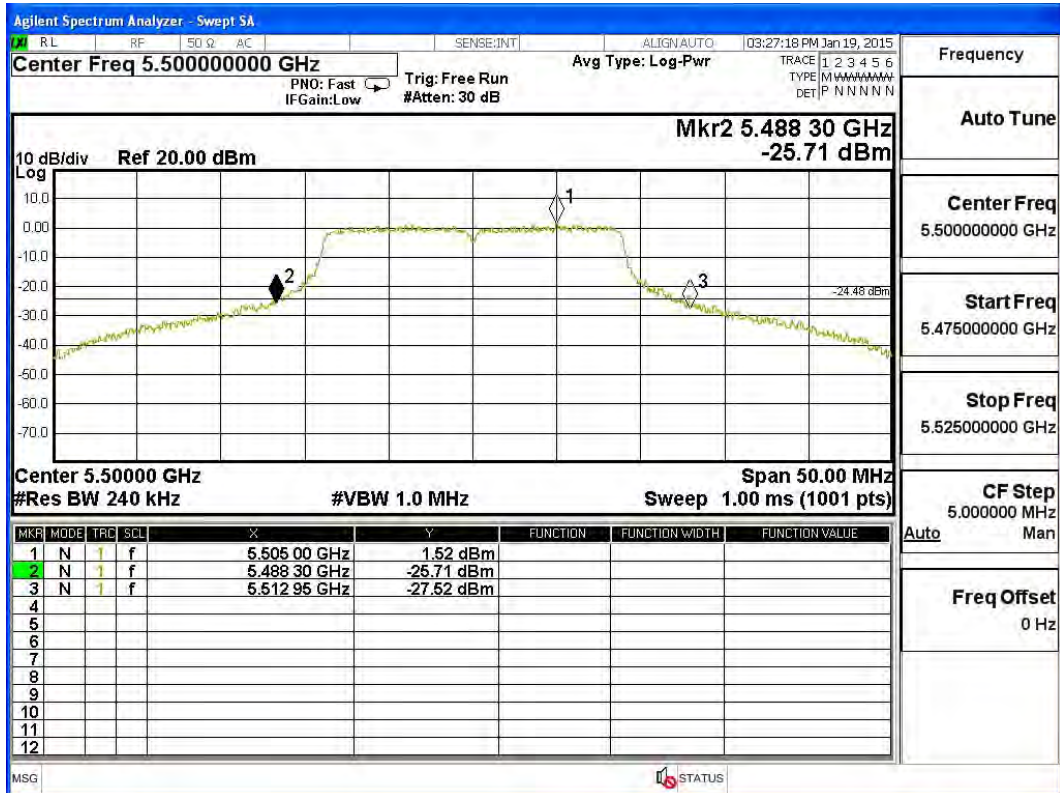

Channel 116 -Chain B

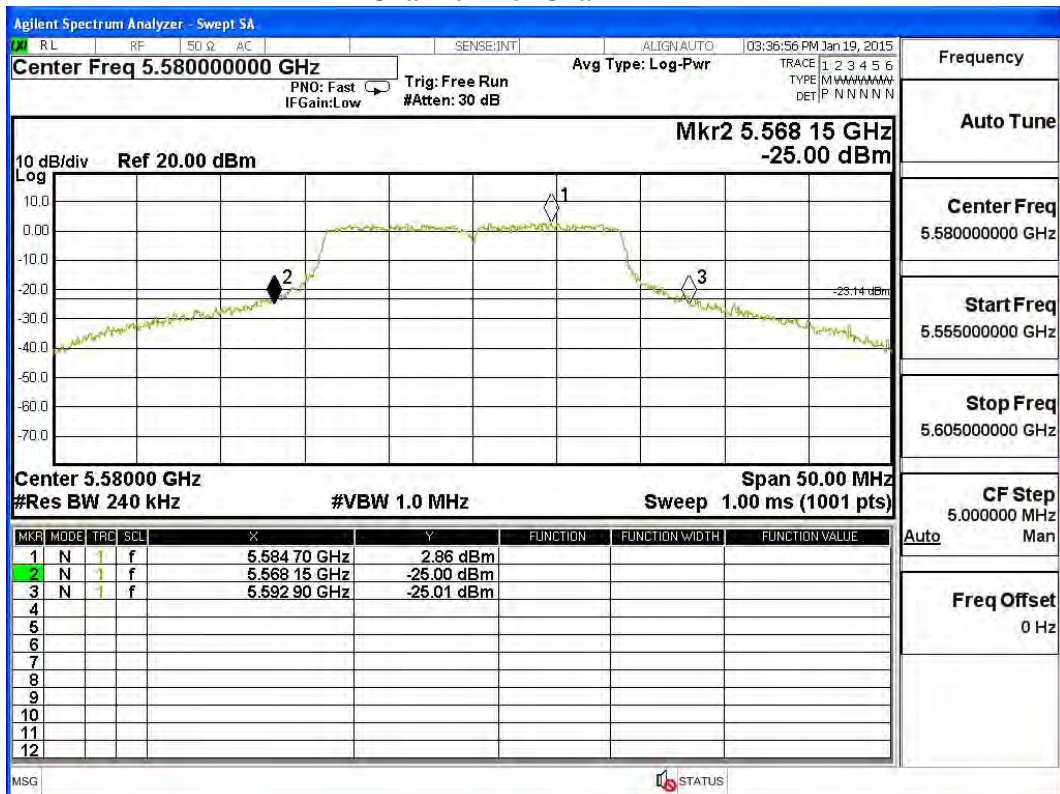

Channel 140 -Chain B

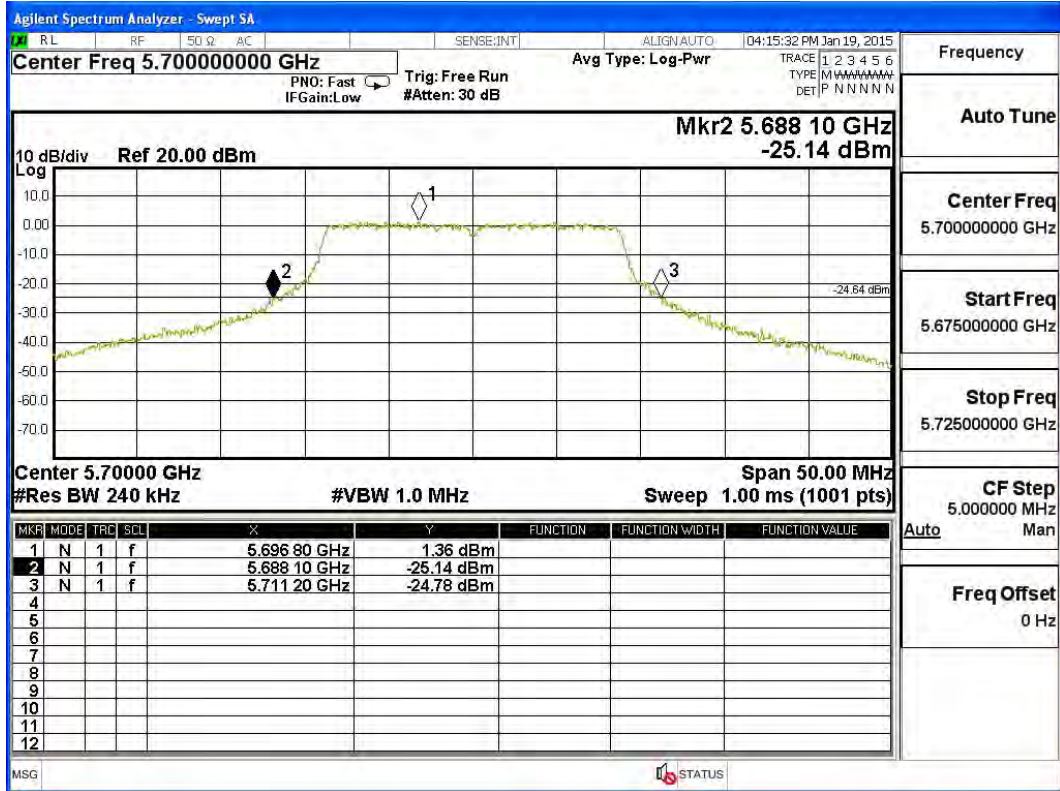

Product : Wireless Access Point
 Test Item : Maximum conducted output power
 Test Site : No.3 OATS
 Test Mode : Mode 3: Transmit (802.11n-40BW 30Mbps) (External Antenna)

CHAIN A

Cable loss=1dB		Maximum conducted output power								
Channel No.	Frequency (MHz)	Data Rate (Mbps)								Required Limit
		30	60	90	120	180	240	270	300	
		Measurement Level (dBm)								
38	5190	10.4	--	--	--	--	--	--	--	<17dBm
46	5230	10.53	10.44	10.36	10.26	10.18	10.08	9.92	9.81	<17dBm
54	5270	10.27	--	--	--	--	--	--	--	<24dBm
62	5310	9.96	9.88	9.8	9.75	9.64	9.59	9.42	9.38	<24dBm
102	5510	12.53	--	--	--	--	--	--	--	<24dBm
110	5550	12.66	12.58	12.5	12.45	12.34	12.24	12.18	12.16	<24dBm
134	5670	13.71	--	--	--	--	--	--	--	<24dBm

Note: Maximum conducted output power Value =Reading value on average power meter + cable loss

CHAIN B

Cable loss=1dB		Maximum conducted output power								
Channel No.	Frequency (MHz)	Data Rate (Mbps)								Required Limit
		30	60	90	120	180	240	270	300	
		Measurement Level (dBm)								
38	5190	10.5	--	--	--	--	--	--	--	<17dBm
46	5230	10.22	10.11	10.03	9.89	9.77	9.67	9.56	9.42	<17dBm
54	5270	10.64	--	--	--	--	--	--	--	<24dBm
62	5310	10.79	10.72	10.65	10.57	10.51	10.42	10.37	10.31	<24dBm
102	5510	13.11	--	--	--	--	--	--	--	<24dBm
110	5550	12.96	12.88	12.8	12.74	12.64	12.58	12.48	12.41	<24dBm
134	5670	13.84	--	--	--	--	--	--	--	<24dBm

Note: Maximum conducted output power Value =Reading value on average power meter + cable loss

Maximum conducted output power Measurement:

(CHAIN A+ B)

Channel Number	Frequency (MHz)	26dB Bandwidth (MHz)	Chain A Power (dBm)	Chain B Power (dBm)	Output Power (dBm)	Output Power Limit	
						(dBm)	dBm+10log(BW)
38	5190	44.200	10.40	10.50	13.46	17	20.45
46	5230	43.500	10.53	10.22	13.39	17	20.38
54	5270	43.100	10.27	10.64	13.47	24	27.34
62	5310	43.200	9.96	10.79	13.41	24	27.35
102	5510	45.600	12.53	13.11	15.84	24	27.59
110	5550	44.800	12.66	12.96	15.82	24	27.51
134	5670	45.600	13.71	13.84	16.79	24	27.59

Note:

1. Power Output Value =Reading value on average power meter + cable loss
2. Output Power (dBm) = 10LOG (Chain A Power (mW)+ Chain B Power (mW))
3. 26 dB Bandwidth is the bandwidth of chain A or chain B whichever is less bandwidth, output power limitation is more stringent.

26dBc Occupied Bandwidth:
Channel 38 – Chain A

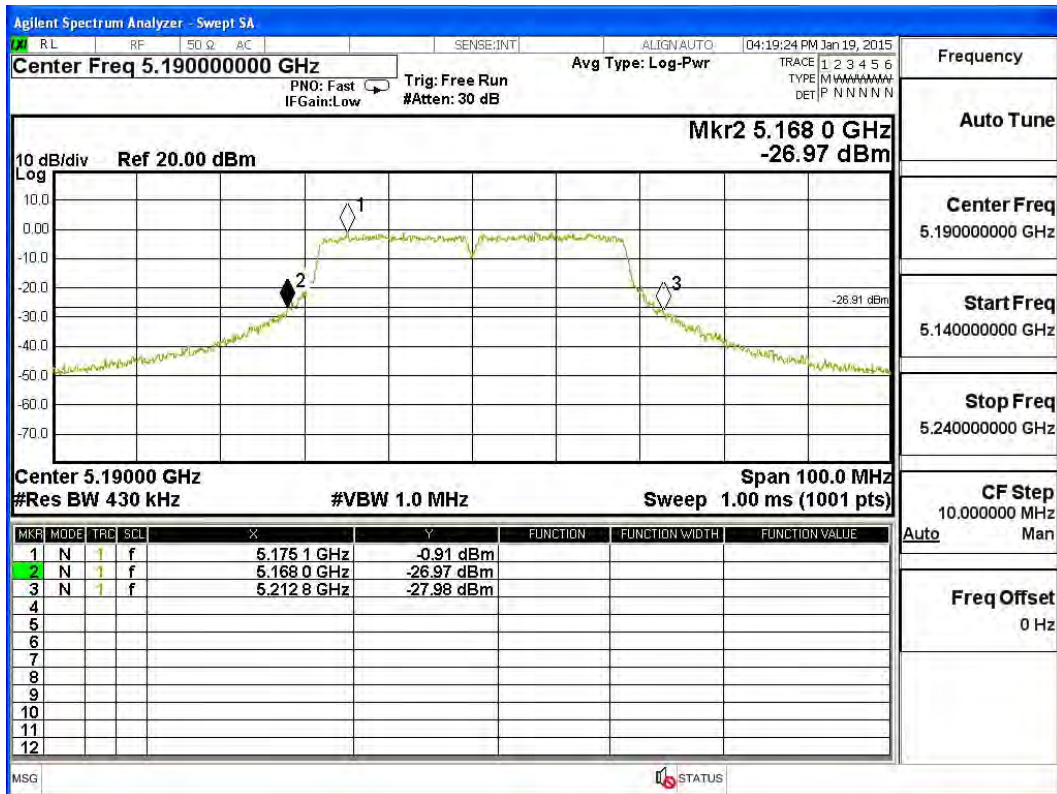

Channel 46 – Chain A

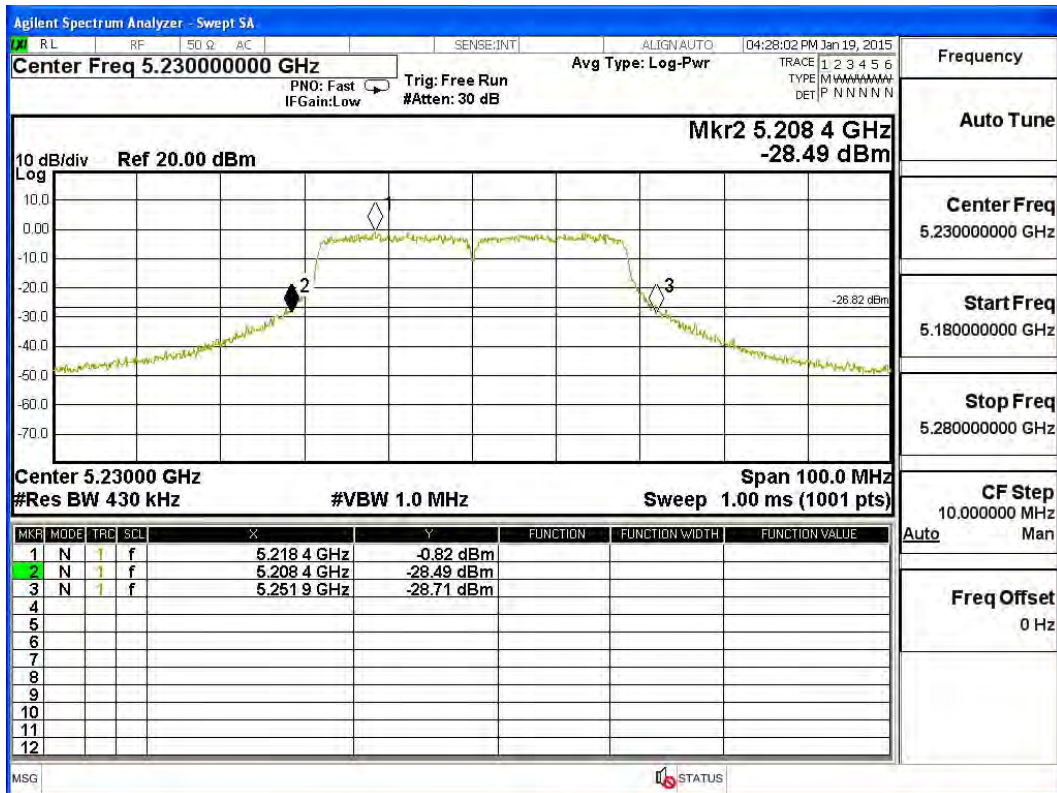

Channel 54 – Chain A

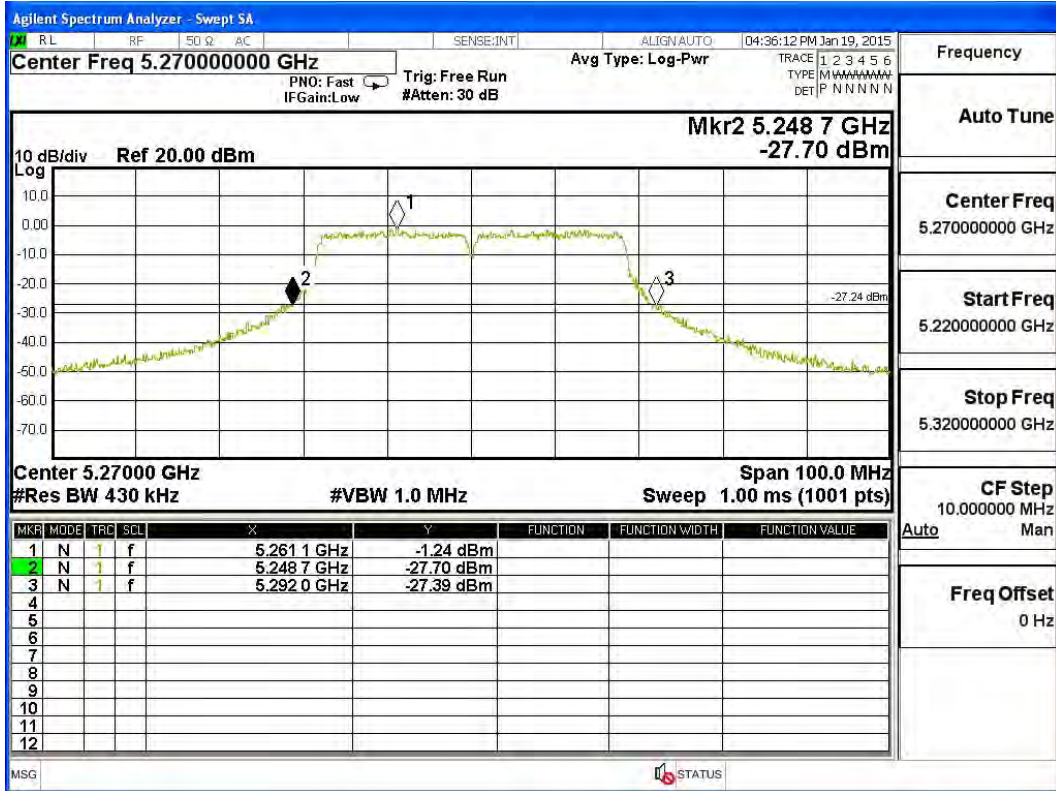

Channel 62 – Chain A

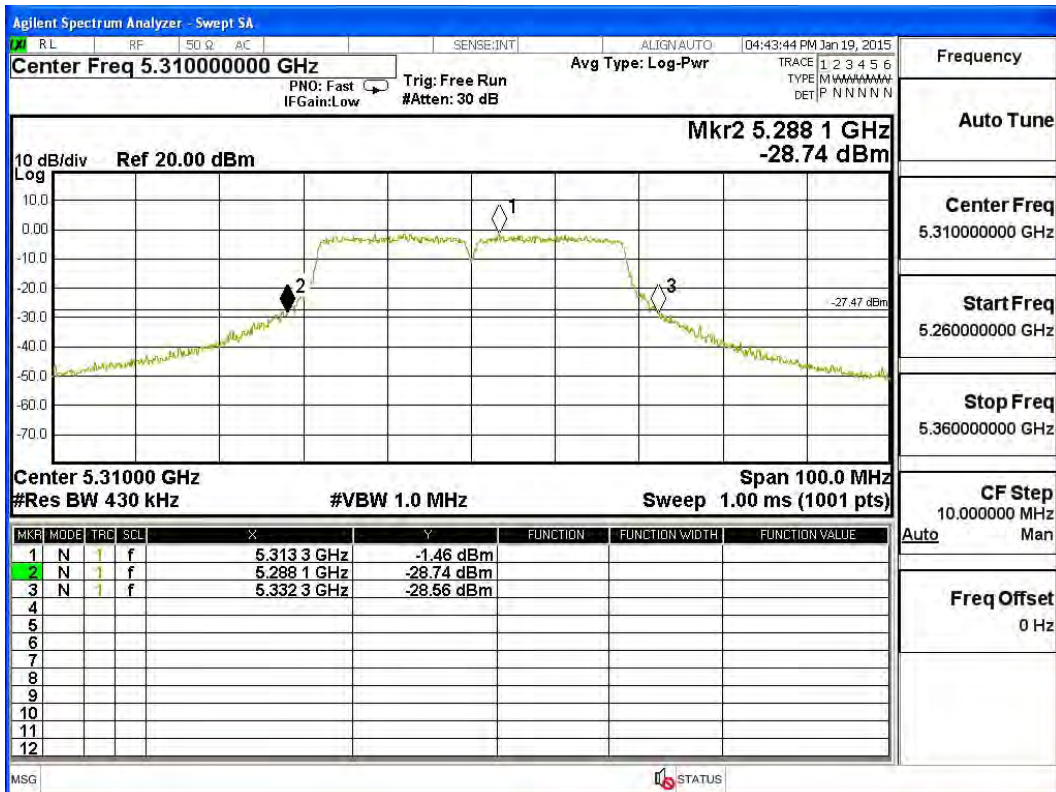

Channel 102 – Chain A

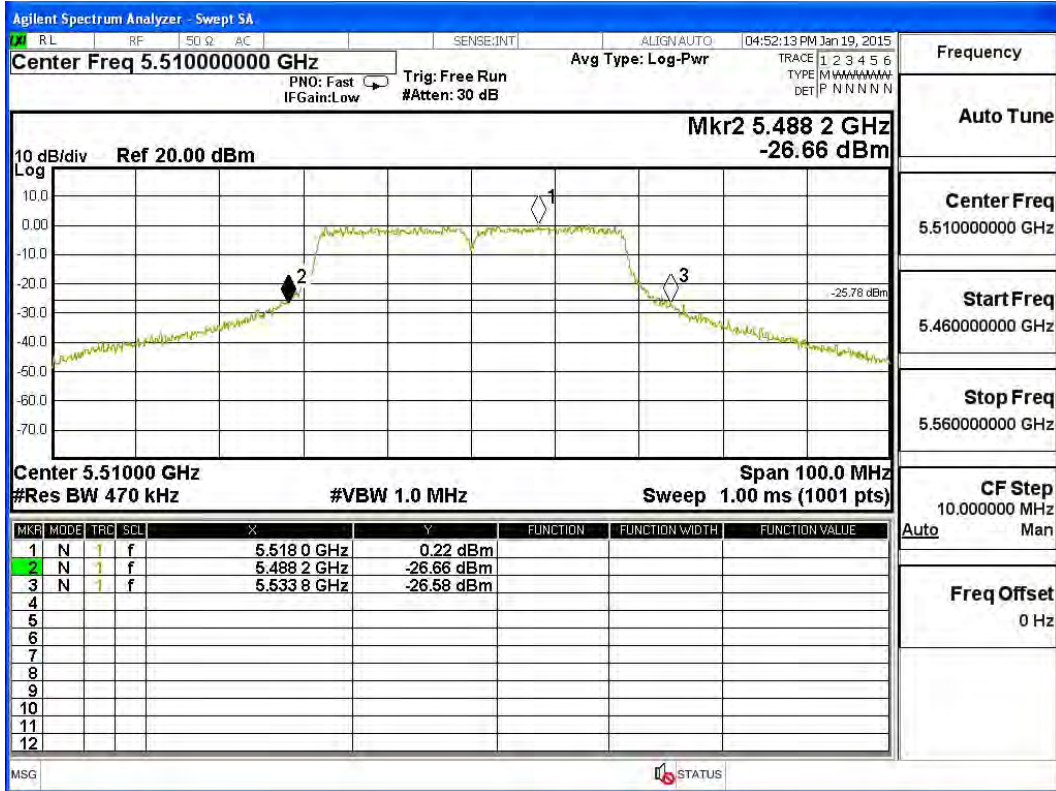

Channel 118 – Chain A

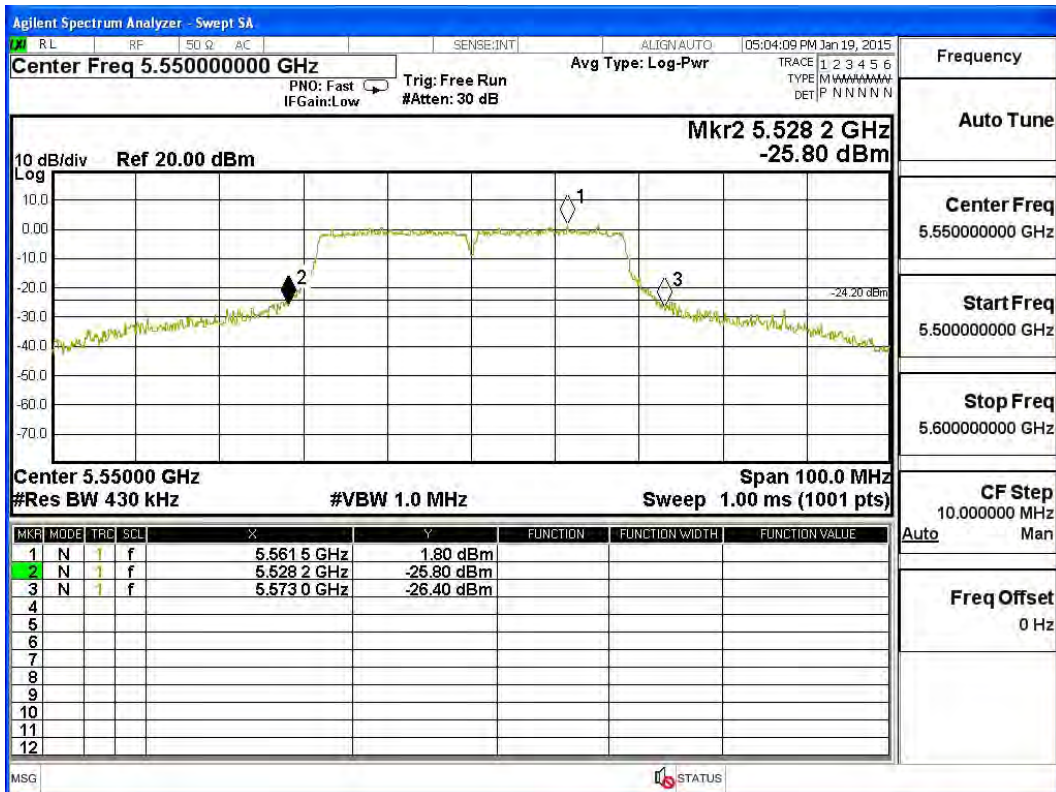

Channel 134 – Chain A

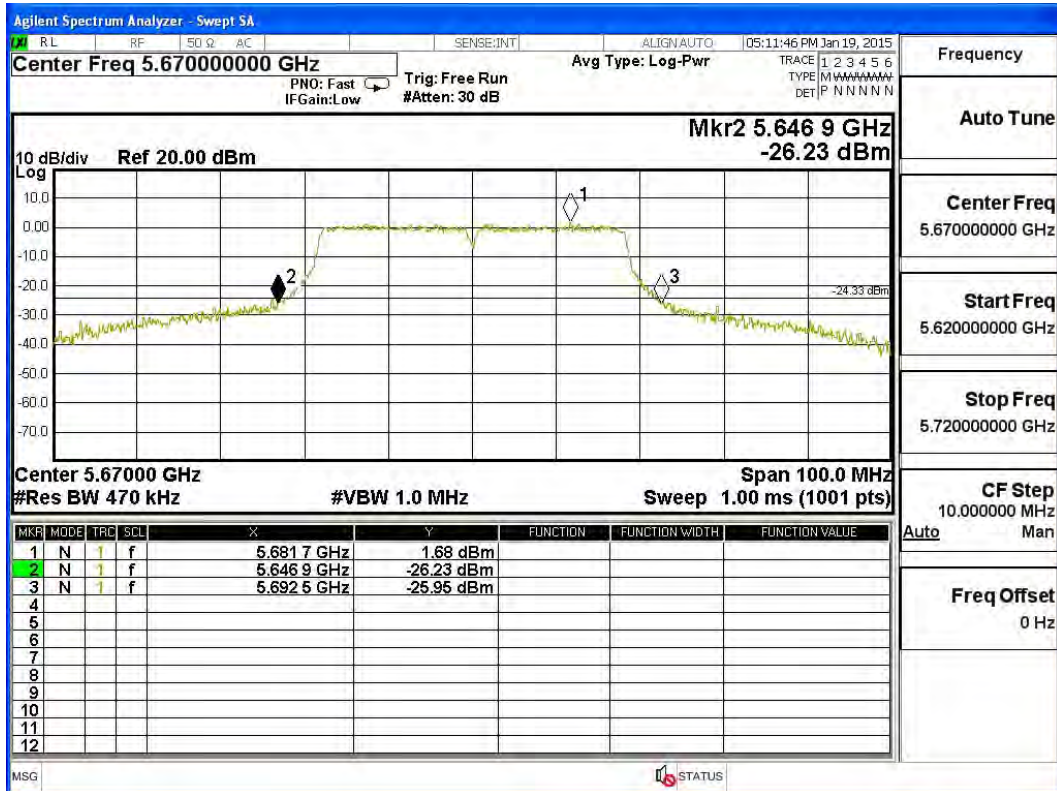

26dBc Occupied Bandwidth:
Channel 38 – Chain B

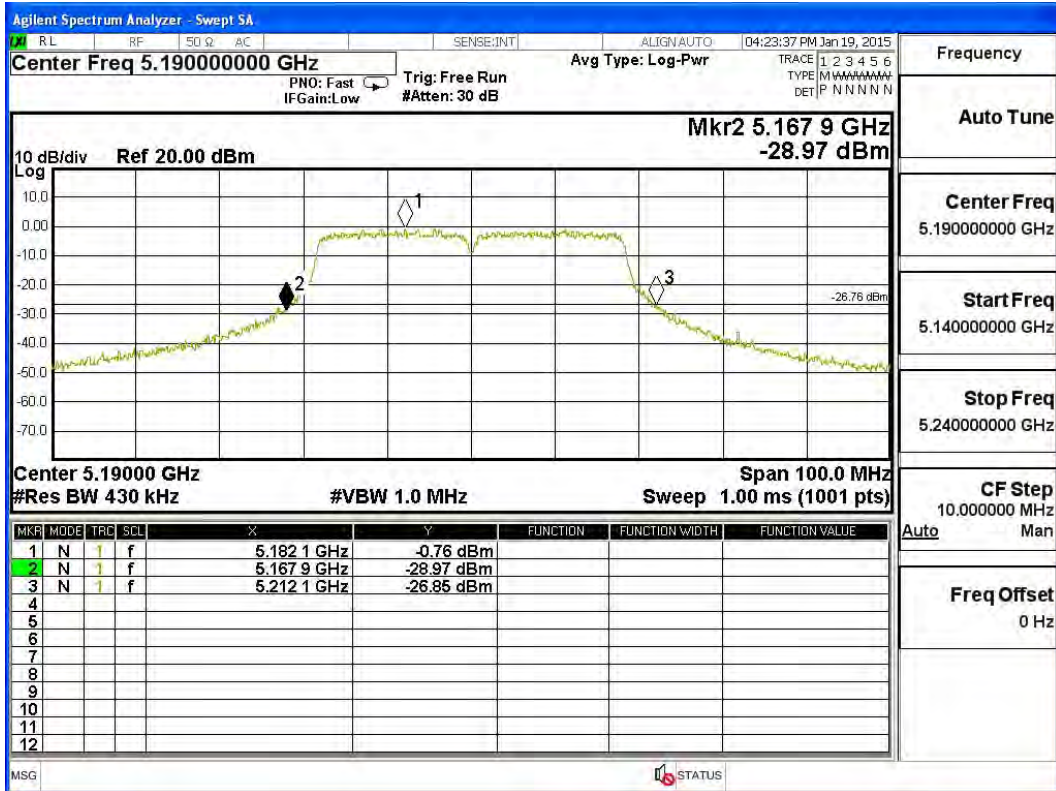

Channel 46 – Chain B

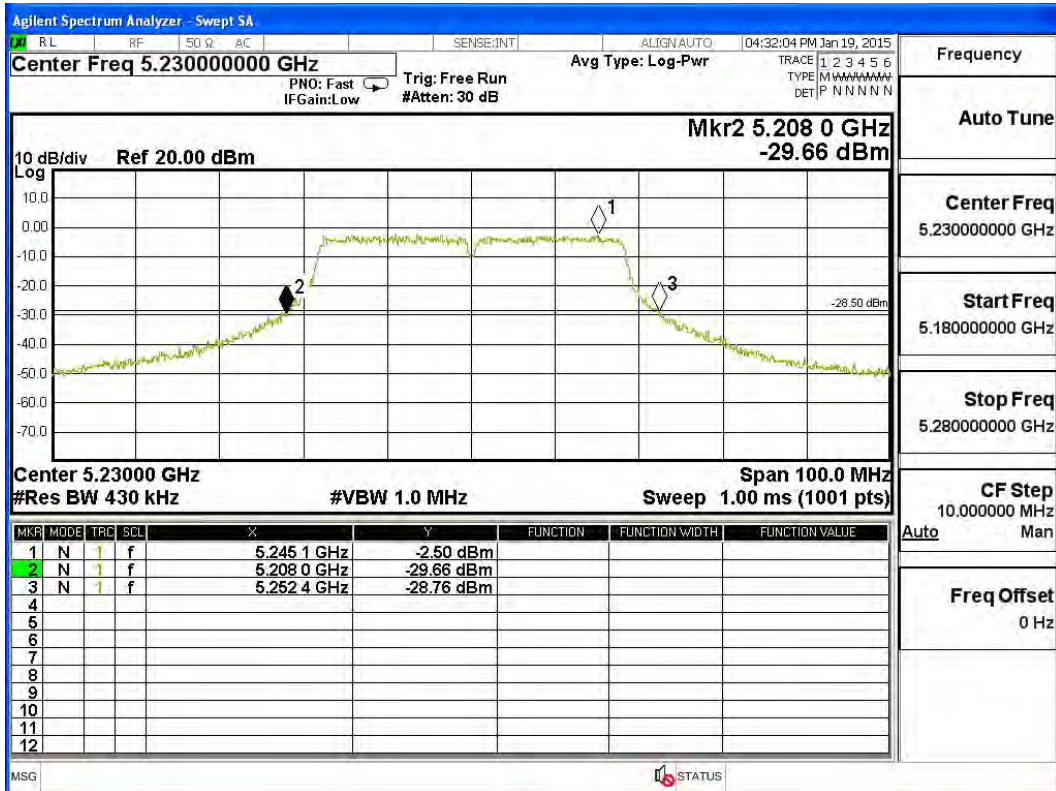

Channel 54 – Chain B

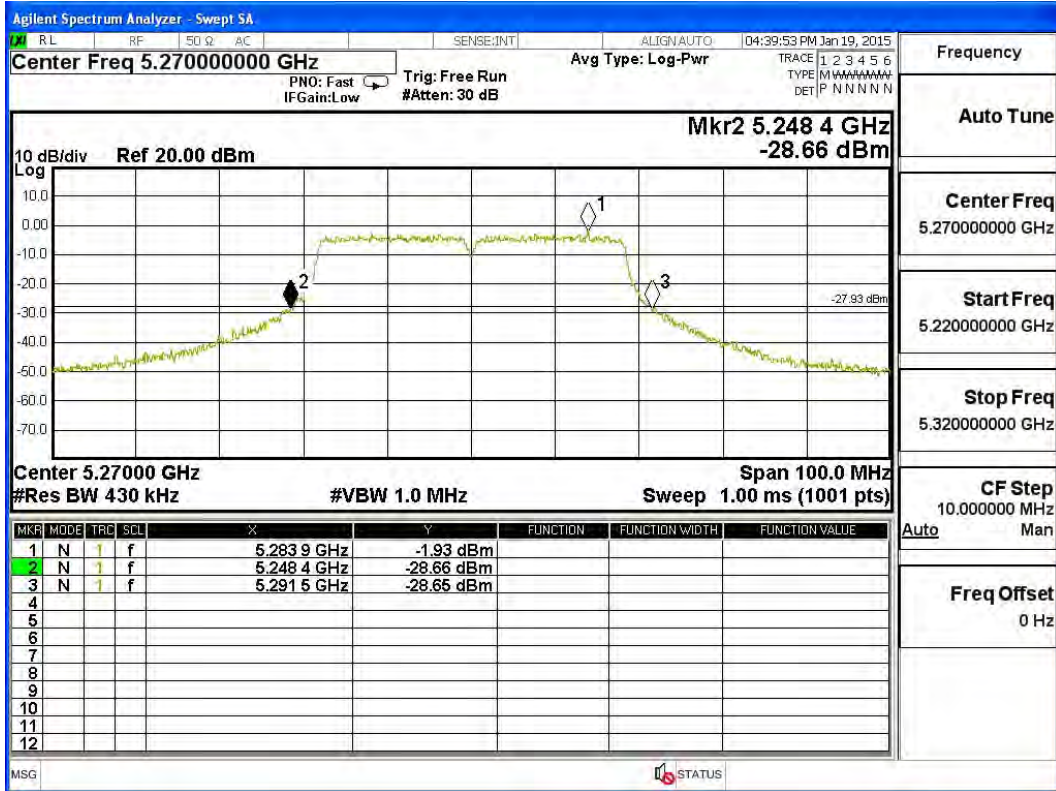

Channel 62 – Chain B

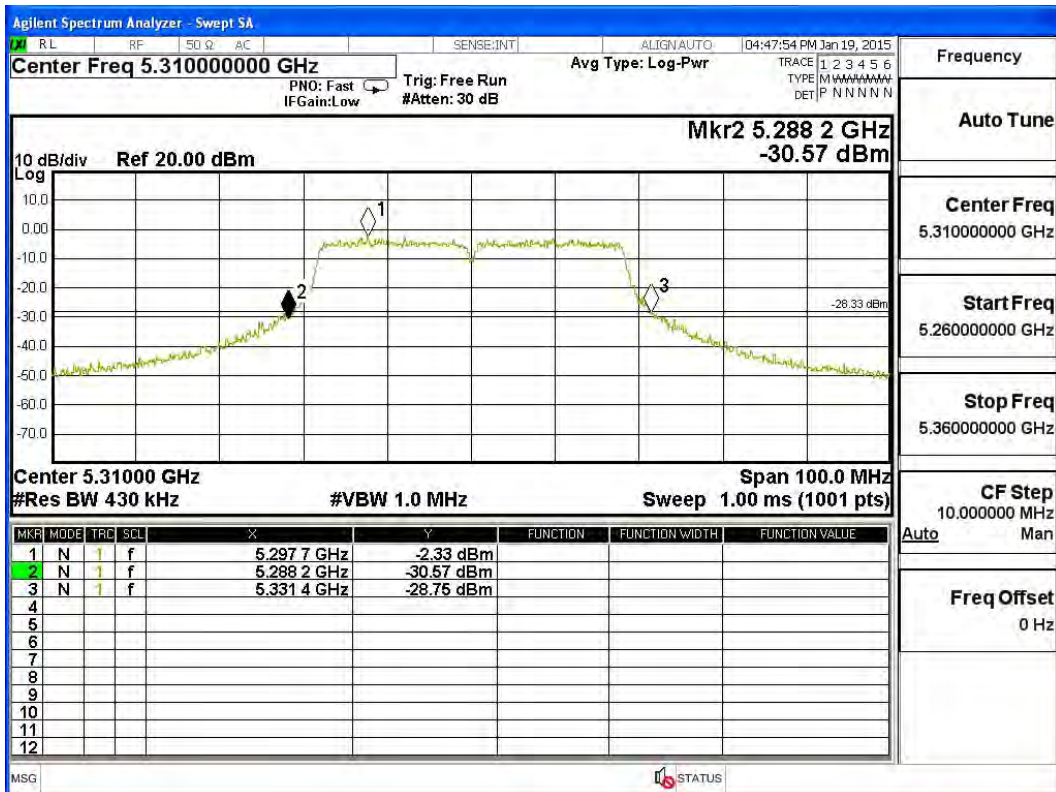

Channel 102 – Chain B

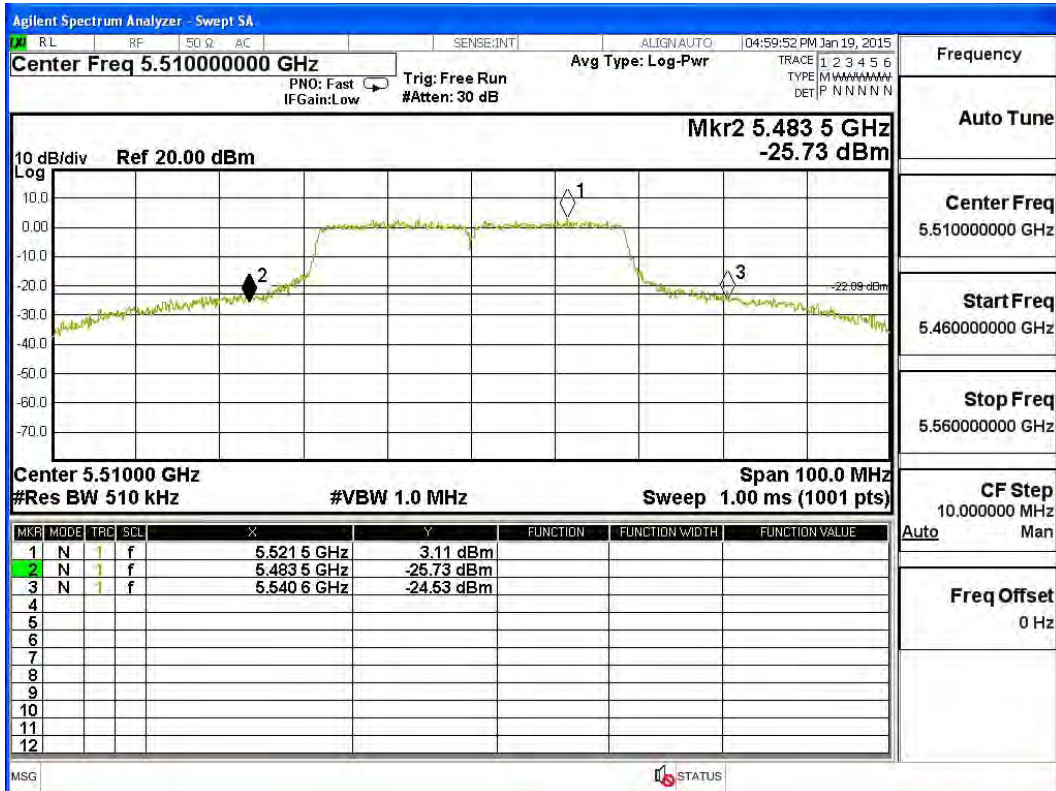

Channel 118 – Chain B

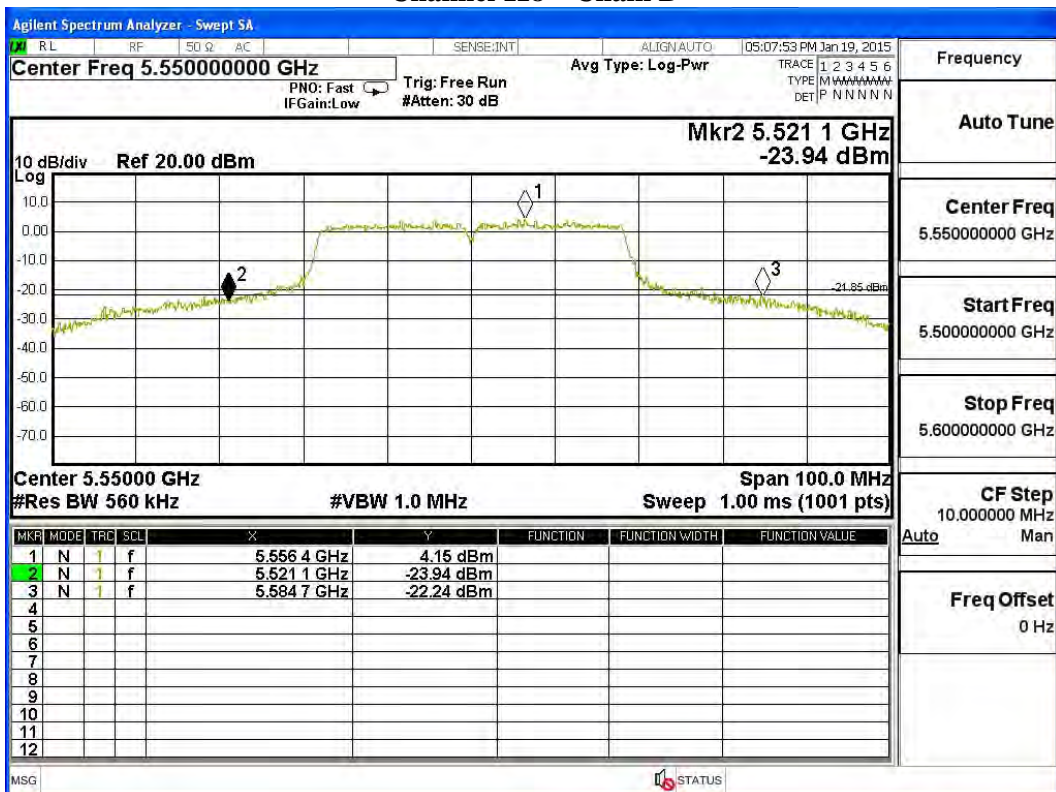

Channel 134 – Chain B

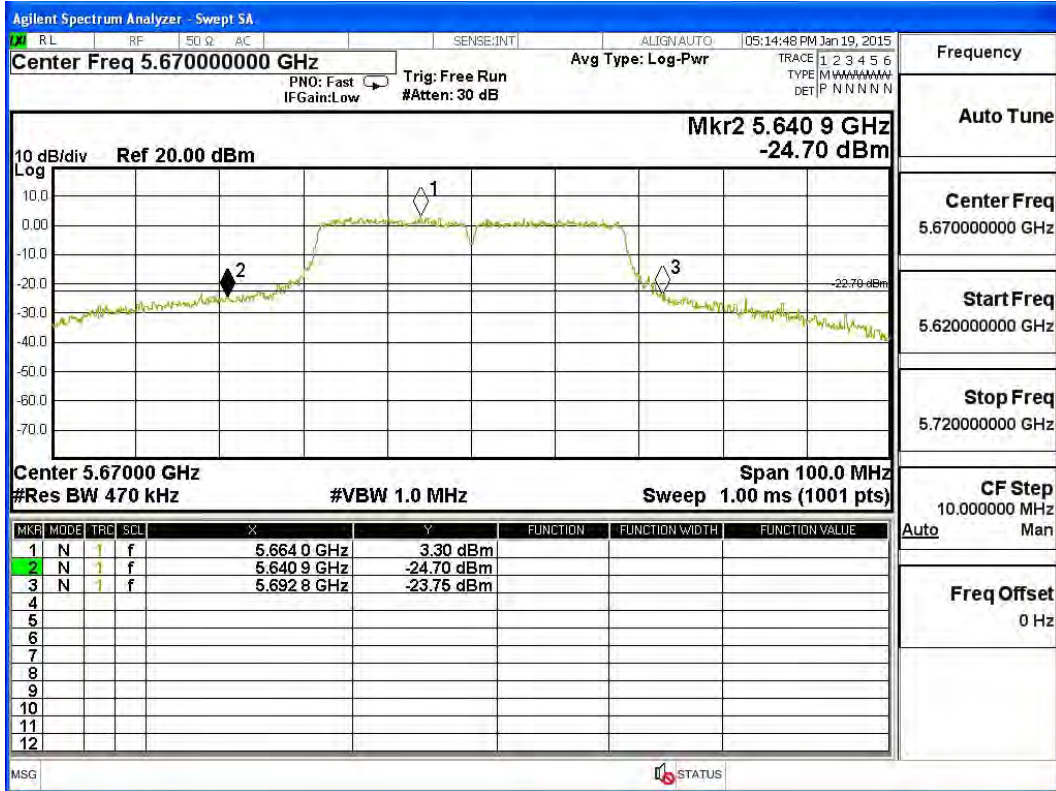

Product : Wireless Access Point
 Test Item : Maximum conducted output power
 Test Site : No.3 OATS
 Test Mode : Mode 4: Transmit (802.11ac-20BW-7.2Mbps) (External Antenna)

Chain A

Cable loss=1dB		Maximum conducted output power									
Channel No.	Frequency (MHz)	Data Rate (Mbps)									Required Limit
		VTH0	VTH1	VTH2	VTH3	VTH4	VTH5	VTH6	VTH7	VTH8	
		Measurement Level (dBm)									
144 (Band3)	5720	8.37	8.26	8.15	8.08	7.93	7.82	7.74	7.6	7.55	<24dBm
144 (Band4)	5720	2.87	2.78	2.69	2.62	2.54	2.42	2.35	2.24	2.24	<30dBm

Note: Maximum conducted output power Value =Reading value on average power meter + cable loss

Chain B

Cable loss=1dB		Maximum conducted output power									
Channel No.	Frequency (MHz)	Data Rate (Mbps)									Required Limit
		VTH0	VTH1	VTH2	VTH3	VTH4	VTH5	VTH6	VTH7	VTH8	
		Measurement Level (dBm)									
144 (Band3)	5720	8.71	8.66	8.61	8.57	8.51	8.43	8.41	8.36	8.32	<24dBm
144 (Band4)	5720	3.17	3.08	2.97	2.9	2.81	2.75	2.63	2.58	2.49	<30dBm

Note: Maximum conducted output power Value =Reading value on average power meter + cable loss

Maximum conducted output power Measurement:

Channel No	Frequency Range (MHz)	26dB Bandwidth (MHz)	Chain A Power (dBm)	Chain B Power (dBm)	Output Power (dBm)	Output Power Limit		Result
						(dBm)	dBm+10log(BW)	
144(Band3)	5720	16.250	8.37	8.71	11.55	24	23.11	Pass
144(Band4)	5720	6.250	2.87	3.17	6.03	30	18.96	Pass

Note: Power Output Value =Reading value on average power meter + cable loss

26dBc Occupied Bandwidth:
Channel 144 – Chain A

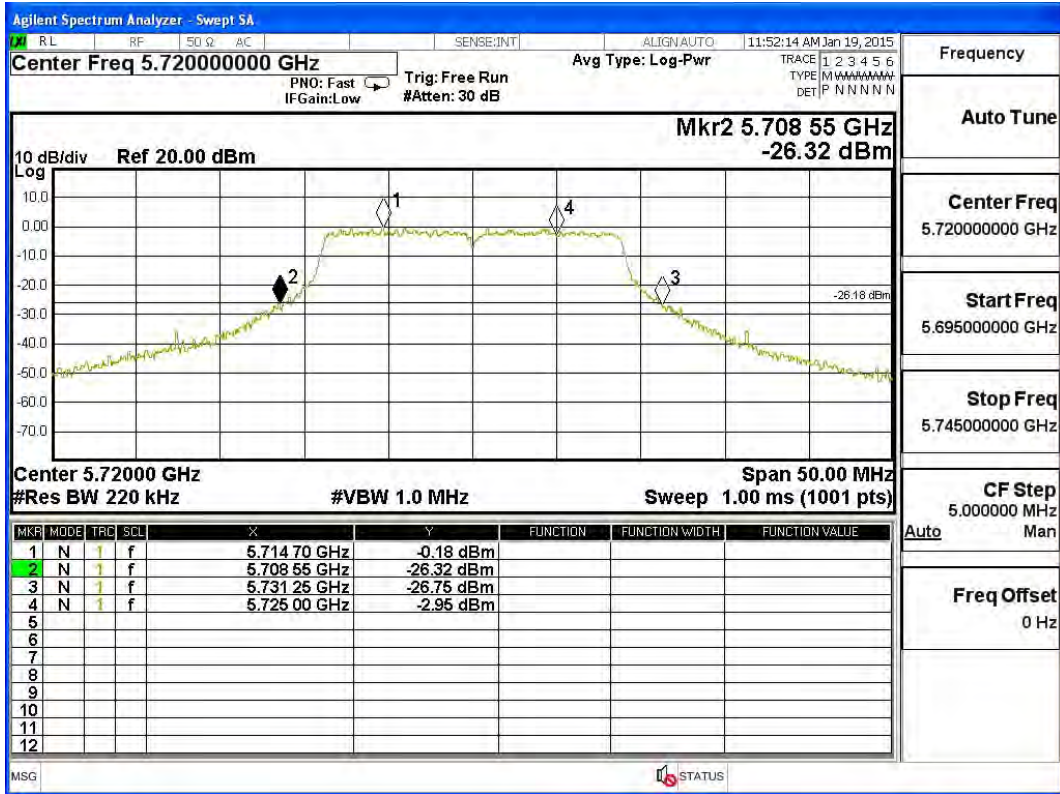

26dBc Occupied Bandwidth:
Channel 144 – Chain B

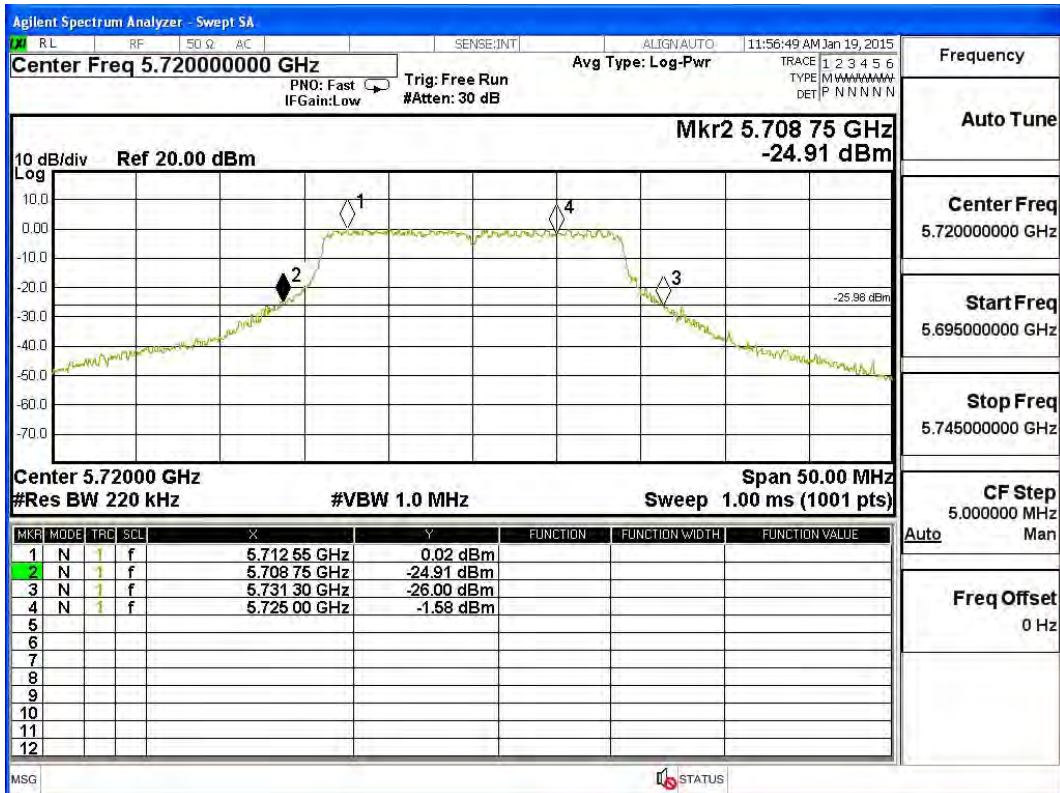

Maximum conducted output power:
Channel 144 (Band3) – Chain A

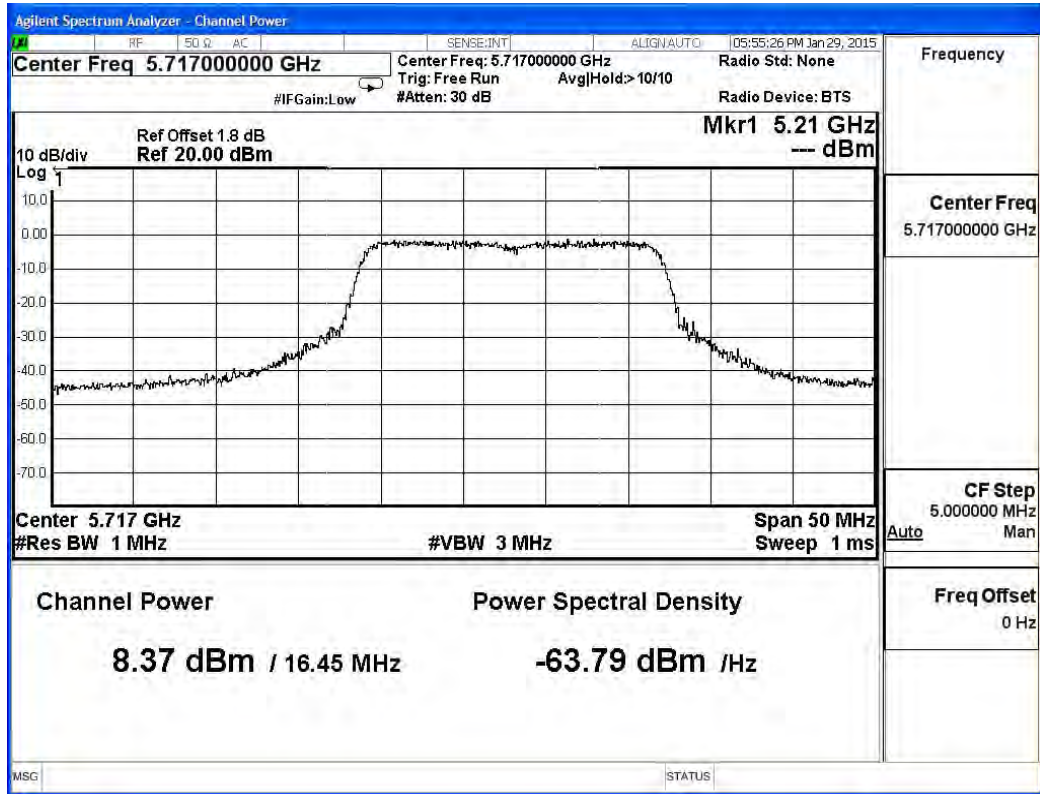

Channel 144 (Band4) – Chain A

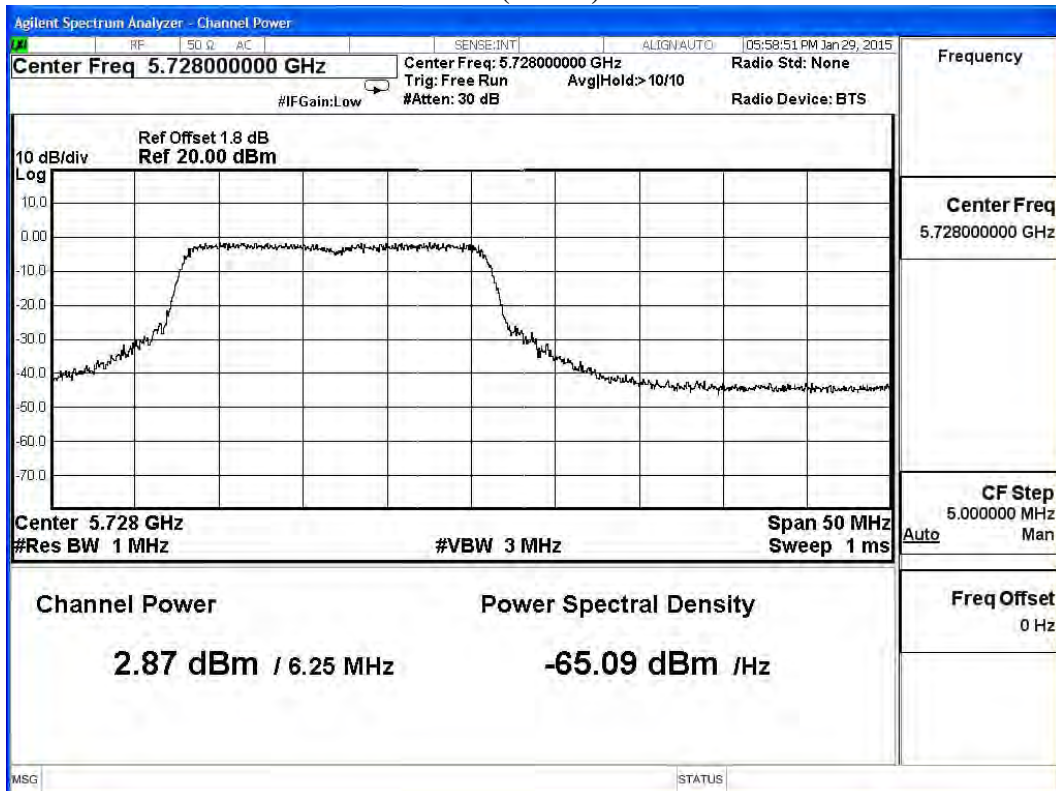

Maximum conducted output power:
Channel 144 (Band3) – Chain B

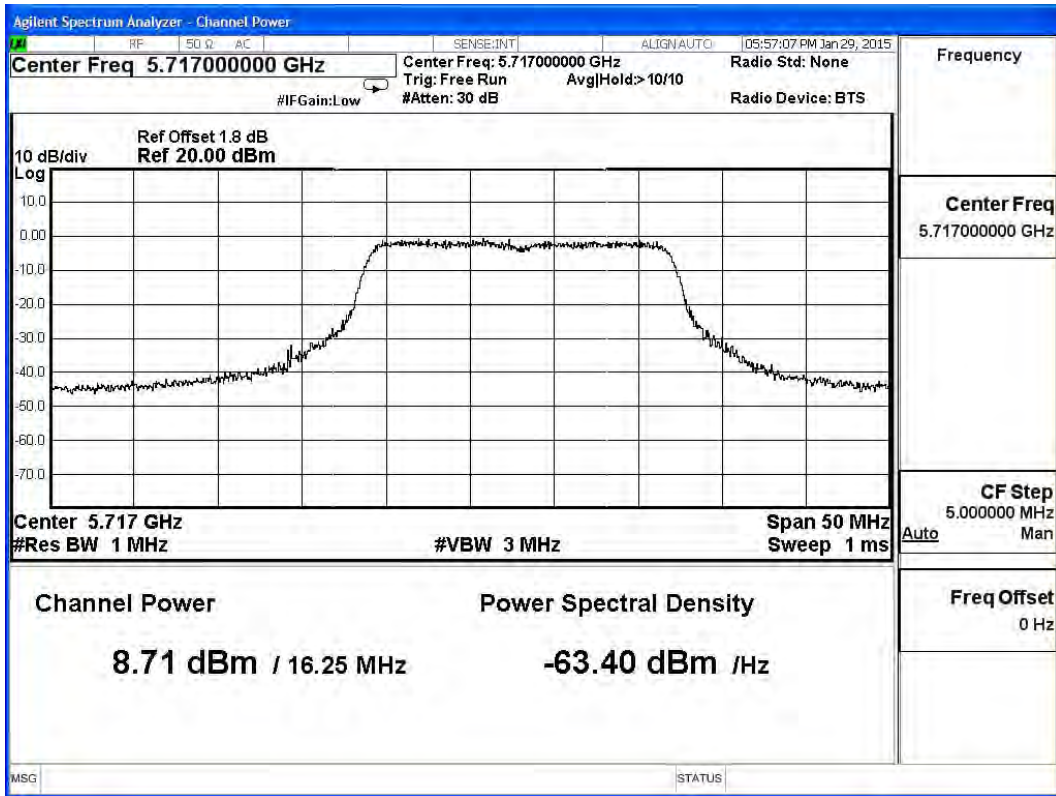

Channel 144 (Band4) – Chain B

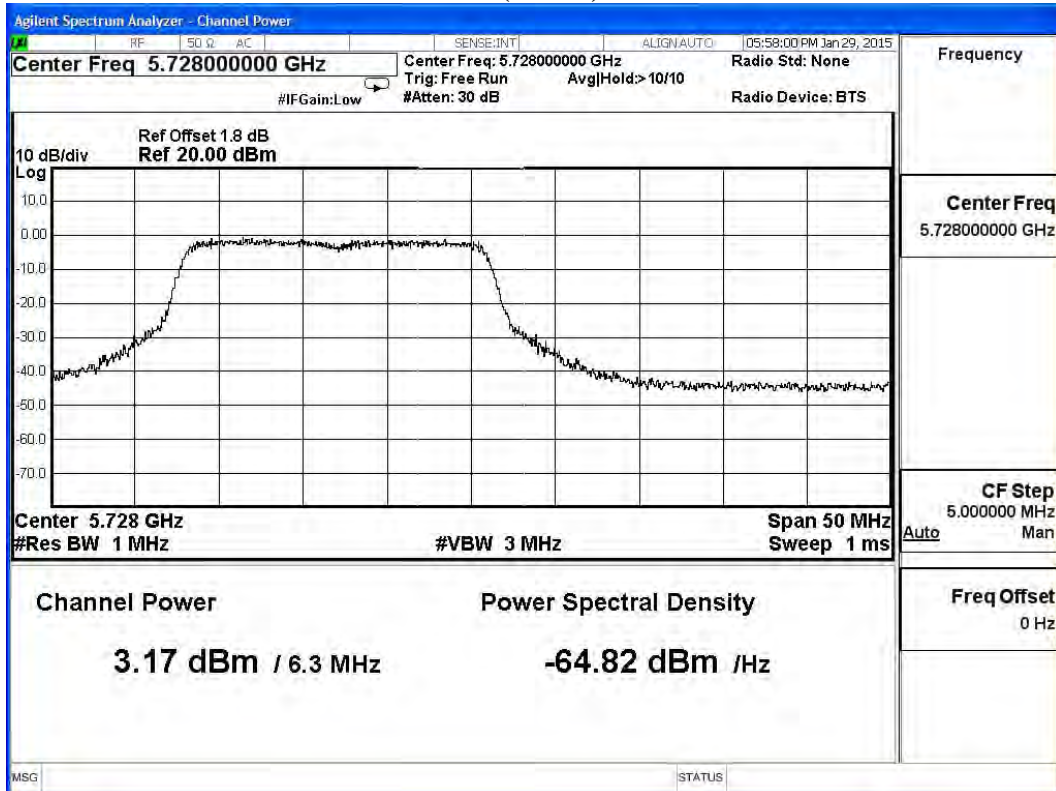

Product : Wireless Access Point
 Test Item : Maximum conducted output power
 Test Site : No.3 OATS
 Test Mode : Mode 5: Transmit (802.11ac-40BW-15Mbps) (External Antenna)

Chain A

Cable loss=1dB		Maximum conducted output power										
Channel No	Frequency (MHz)	Data Rate (Mbps)										Required Limit
		VTH0	VTH1	VTH2	VTH3	VTH4	VTH5	VTH6	VTH7	VTH8	VTH9	
142F(Band3)	5710	9.78	9.71	9.64	9.59	9.5	9.43	9.36	9.29	9.25	9.16	<24dBm
142F(Band4)	5710	-1.17	-1.22	-1.27	-1.35	-1.37	-1.42	-1.47	-1.52	-1.59	-1.62	<30dBm

Note: Maximum conducted output power Value =Reading value on average power meter + cable loss

Chain B

Cable loss=1dB		Maximum conducted output power										
Channel No	Frequency (MHz)	Data Rate (Mbps)										Required Limit
		VTH0	VTH1	VTH2	VTH3	VTH4	VTH5	VTH6	VTH7	VTH8	VTH9	
142F(Band3)	5710	10.12	10.06	10.01	9.94	9.85	9.82	9.76	9.7	9.68	9.58	<24dBm
142F(Band4)	5710	-0.55	-0.61	-0.67	-0.73	-0.79	-0.85	-0.94	-0.97	-1.05	-1.09	<30dBm

Note: Maximum conducted output power Value =Reading value on average power meter + cable loss

Maximum conducted output power Measurement:

Channel No	Frequency Range (MHz)	26dB Bandwidth (MHz)	Chain A Power (dBm)	Chain B Power (dBm)	Output Power (dBm)	Output Power Limit		Result
						(dBm)	dBm+10log(BW)	
142F(Band3)	5710	37.000	9.78	10.12	12.96	24	26.68	Pass
142F(Band4)	5710	6.000	-1.17	-0.55	2.16	30	18.78	Pass

Note: Power Output Value =Reading value on average power meter + cable loss

26dBc Occupied Bandwidth:
Channel 142 – Chain A

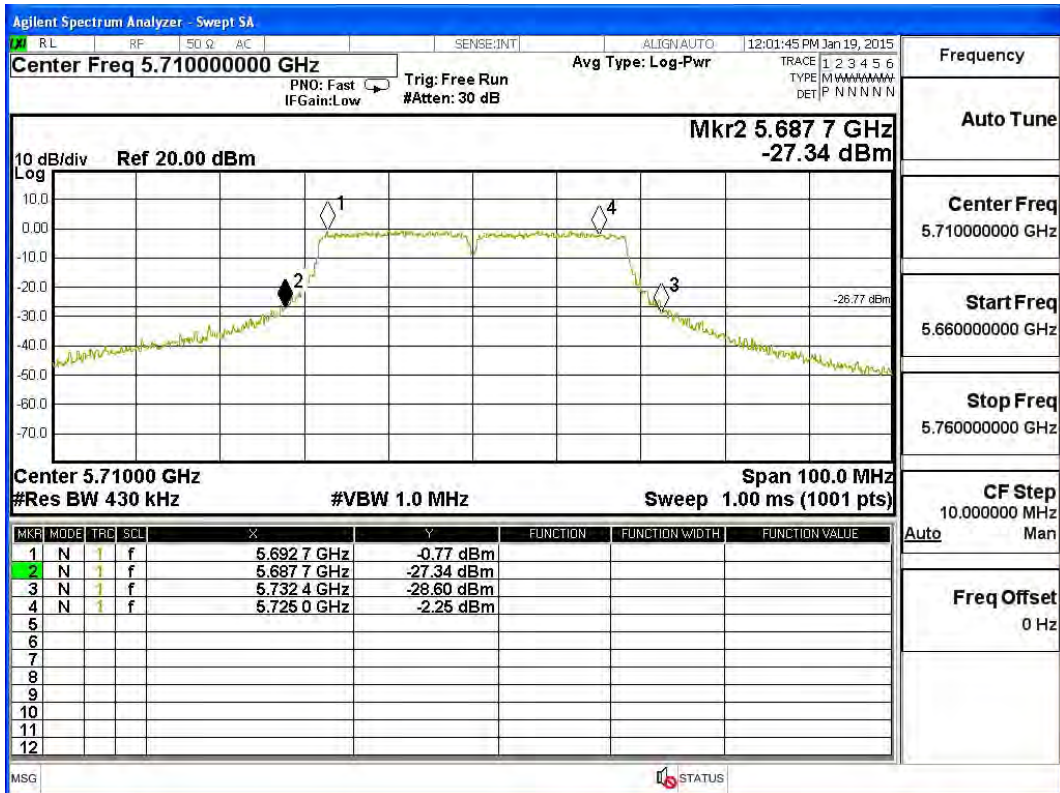

26dBc Occupied Bandwidth:
Channel 142 – Chain B

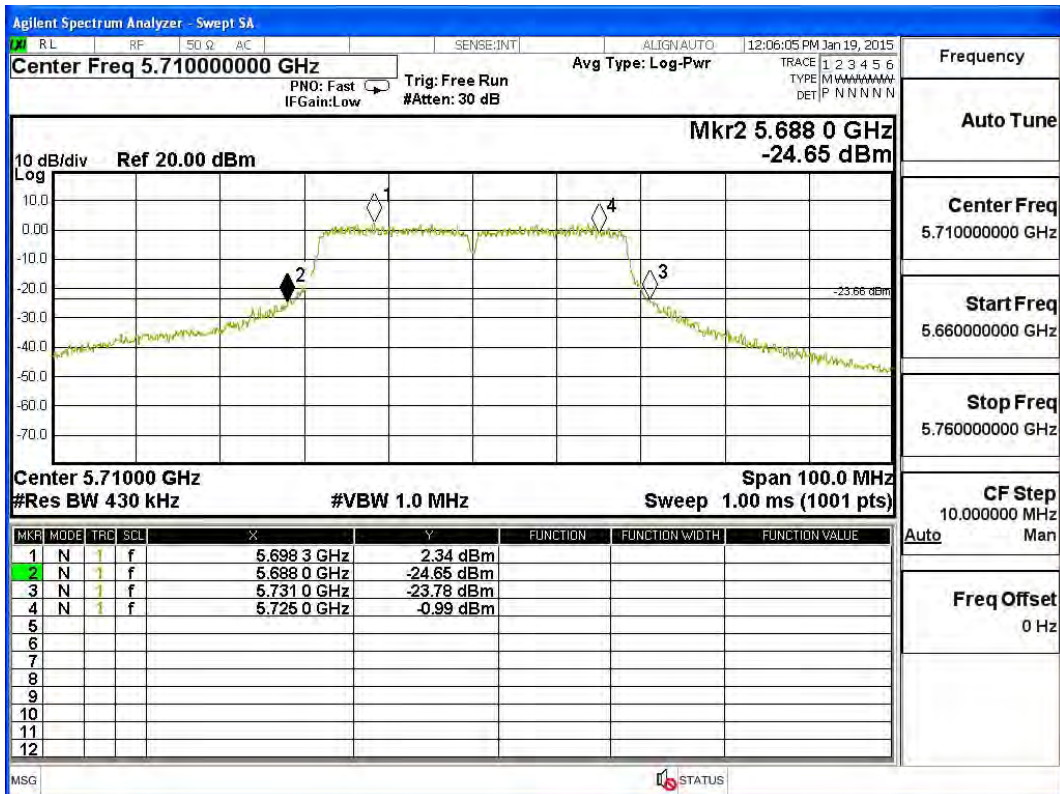

Maximum conducted output power:
Channel 142 (Band3) – Chain A

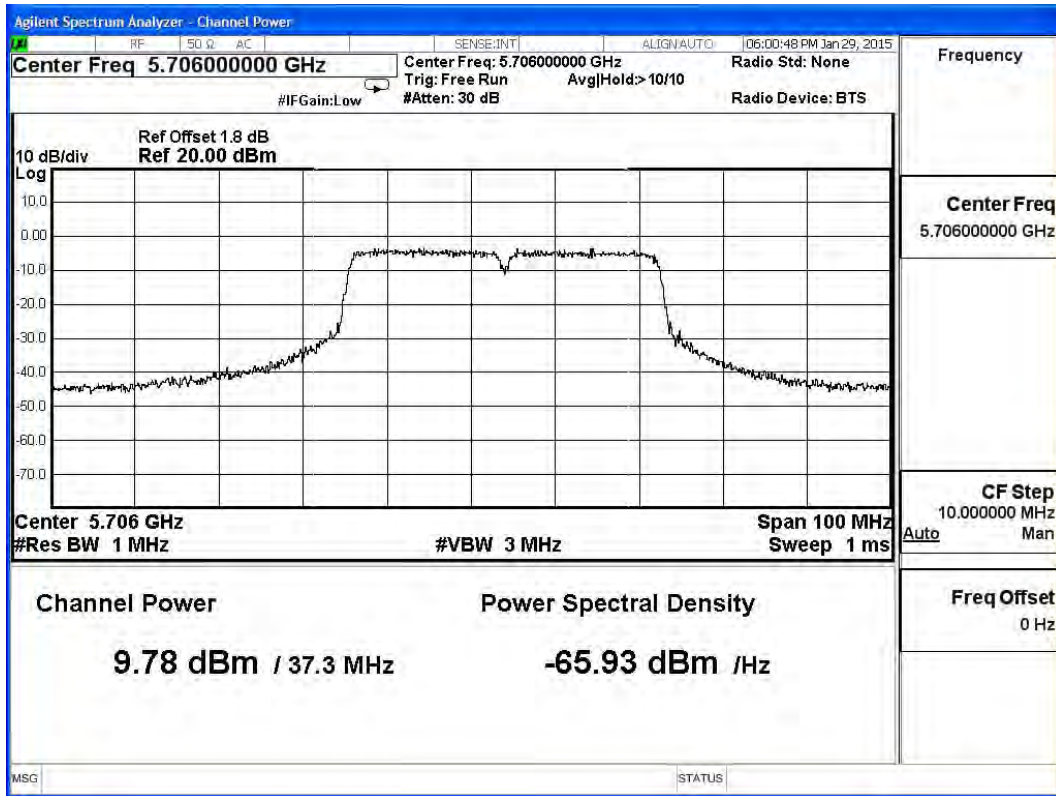

Channel 142 (Band4) – Chain A

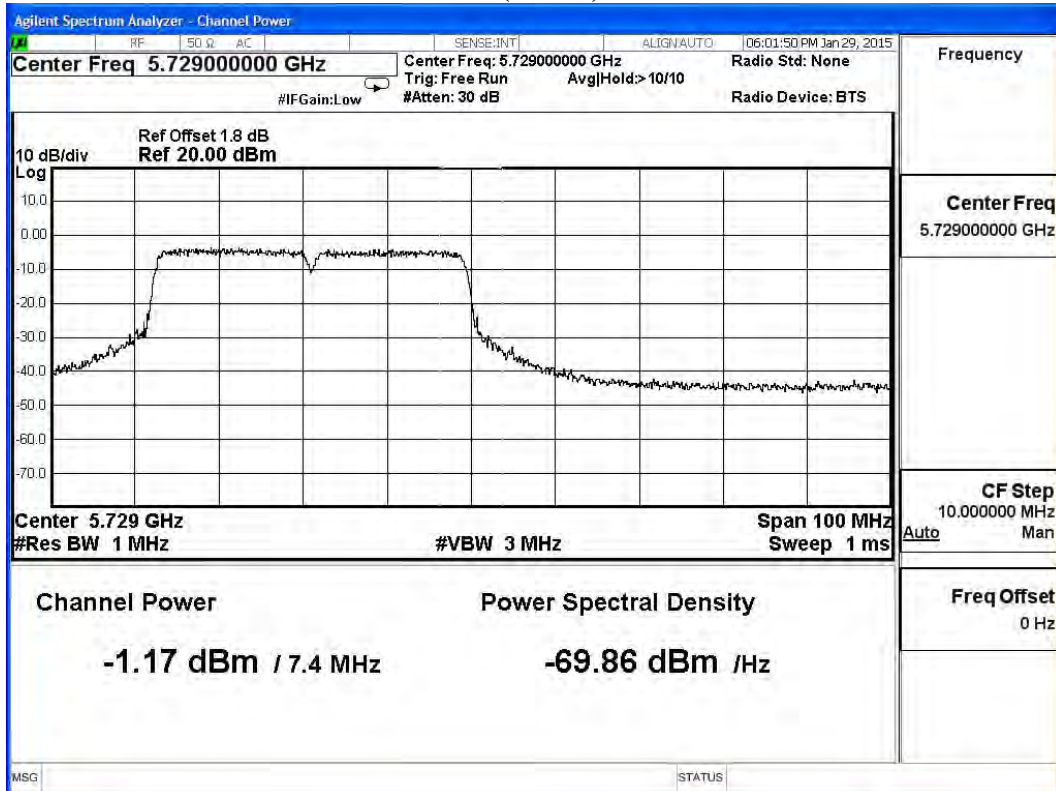

Maximum conducted output power:
Channel 142 (Band3) – Chain B

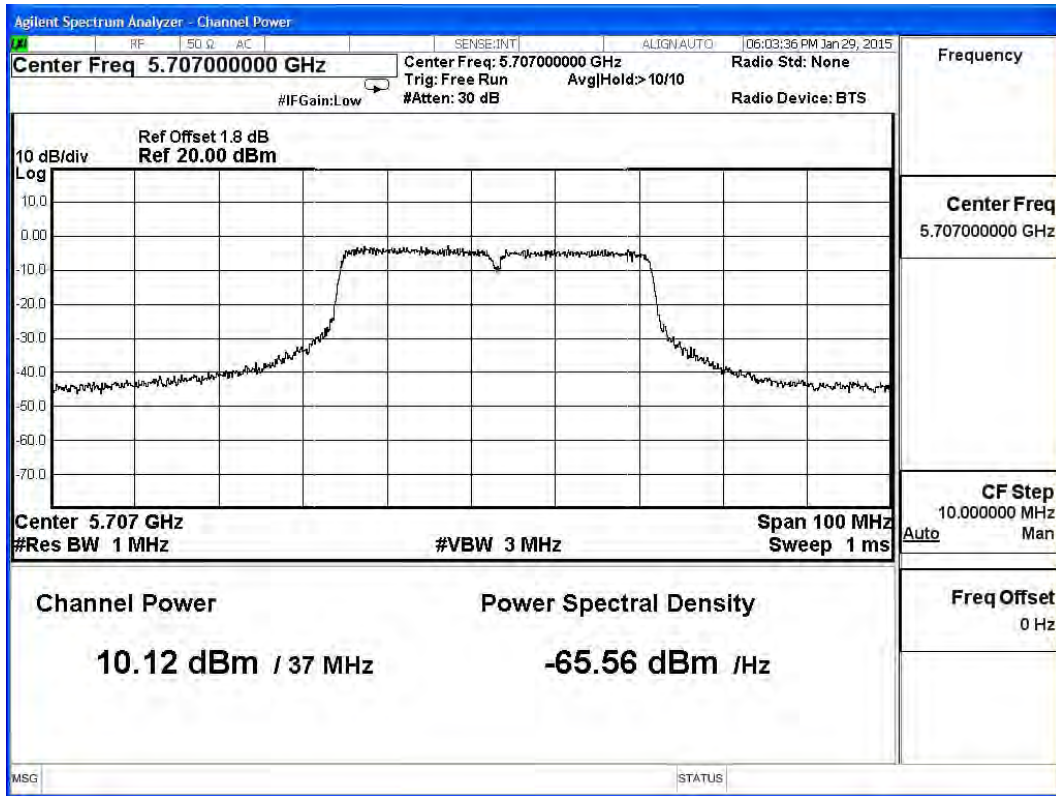

Channel 142 (Band4) – Chain B

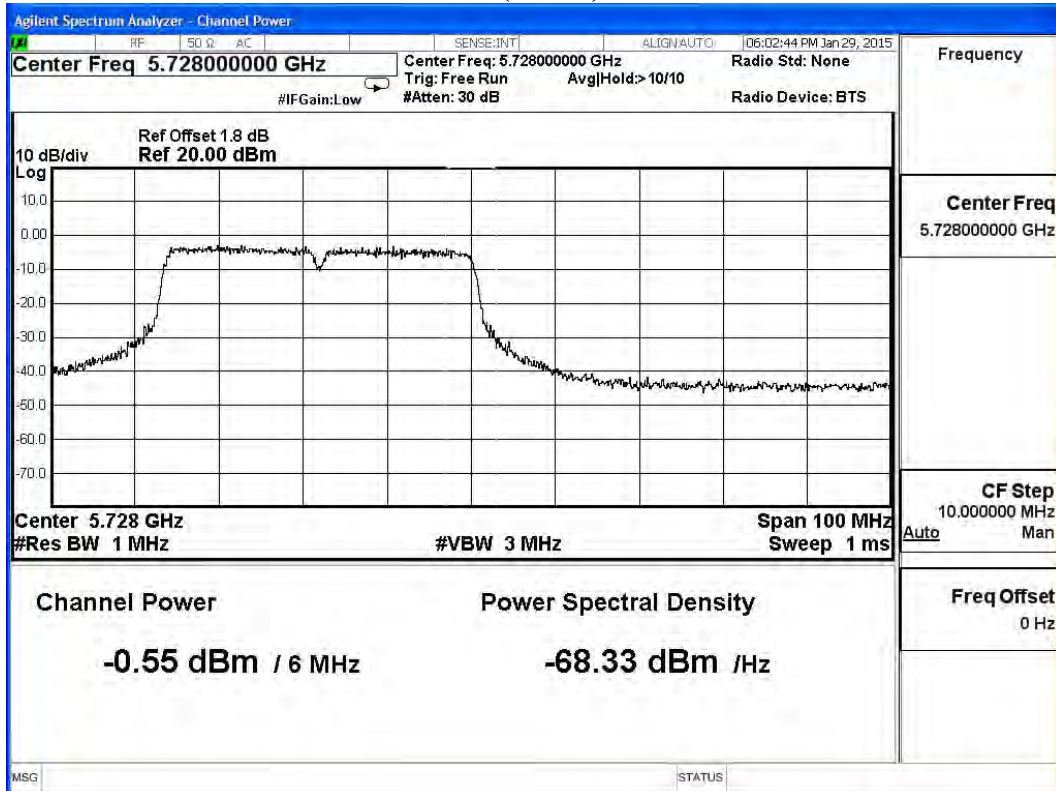

Product : Wireless Access Point
 Test Item : Maximum conducted output power
 Test Site : No.3 OATS
 Test Mode : Mode 6: Transmit (802.11ac-80BW-65Mbps) (External Antenna)

Chain A

Cable loss=1dB		Maximum conducted output power										
Channel No	Frequency (MHz)	Data Rate (Mbps)										Required Limit
		VTH0	VTH1	VTH2	VTH3	VTH4	VTH5	VTH6	VTH7	VTH8	VTH9	
42	5210	8.53	8.48	8.43	8.38	8.39	8.28	8.23	8.18	8.13	8.09	<24dBm
58	5290	8.12	8.07	8.02	7.97	7.92	7.87	7.82	7.76	7.72	7.67	<24dBm
106	5530	6.89	6.84	6.79	6.77	6.69	6.61	6.59	6.54	6.49	6.43	<24dBm
138(Band3)	5690	10.29	10.22	10.15	10.08	10.01	9.94	9.87	9.81	9.73	9.66	<24dBm
138(Band4)	5690	-4.37	-4.42	-4.47	-4.55	-4.57	-4.62	-4.67	-4.72	-4.78	-4.82	<30dBm

Note: Maximum conducted output power Value =Reading value on average power meter + cable loss

Chain B

Cable loss=1dB		Maximum conducted output power										
Channel No	Frequency (MHz)	Data Rate (Mbps)										Required Limit
		VTH0	VTH1	VTH2	VTH3	VTH4	VTH5	VTH6	VTH7	VTH8	VTH9	
42	5210	7.7	7.4	7.12	6.89	6.5	6.22	5.9	5.63	5.32	5.25	<24dBm
58	5290	6.58	6.47	6.36	6.25	6.14	6.03	5.98	5.81	5.7	5.56	<24dBm
106	5530	8.11	8.07	8.03	7.97	7.95	7.91	7.85	7.83	7.79	7.75	<24dBm
138(Band3)	5690	10.7	10.66	10.62	10.58	10.54	10.52	10.46	10.42	10.38	10.36	<24dBm
138(Band4)	5690	-4.33	-4.38	-4.43	-4.48	-4.53	-4.58	-4.61	-4.68	-4.72	-4.78	<30dBm

Note: Maximum conducted output power Value =Reading value on average power meter + cable loss

Maximum conducted output power Measurement:

Note: Power Output Value =Reading value on average power meter + cable loss

Channel No	Frequency Range (MHz)	26dB Bandwidth (MHz)	Chain A Power (dBm)	Chain B Power (dBm)	Output Power (dBm)	Output Power Limit		Result
						(dBm)	dBm+10log(BW)	
42	5210	90.600	8.53	7.70	11.15	17	30.57	Pass
58	5290	91.000	8.12	6.58	10.43	17	30.59	Pass
106	5530	90.200	6.89	8.11	10.55	24	30.55	Pass
138(Band3)	5690	80.000	10.29	10.70	13.51	24	30.03	Pass
138(Band4)	5690	8.200	-4.37	-4.33	-1.34	30	26.14	Pass

26dBc Occupied Bandwidth:
Channel 42 – Chain A

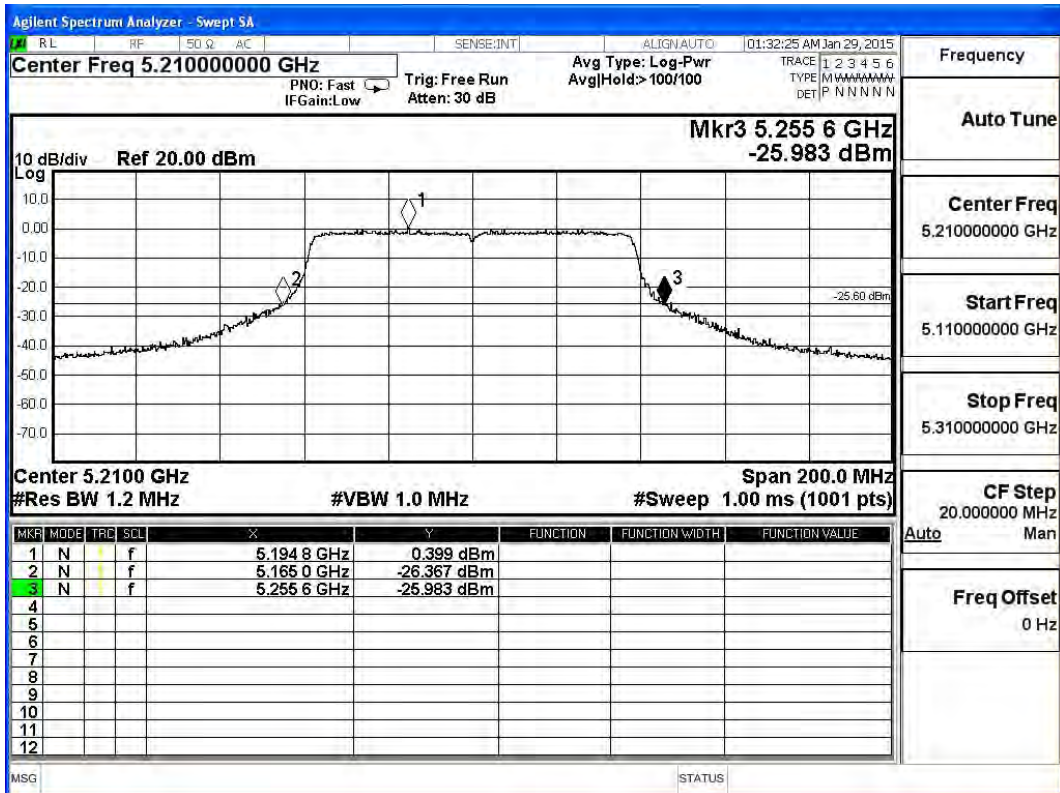

Channel 42 – Chain B

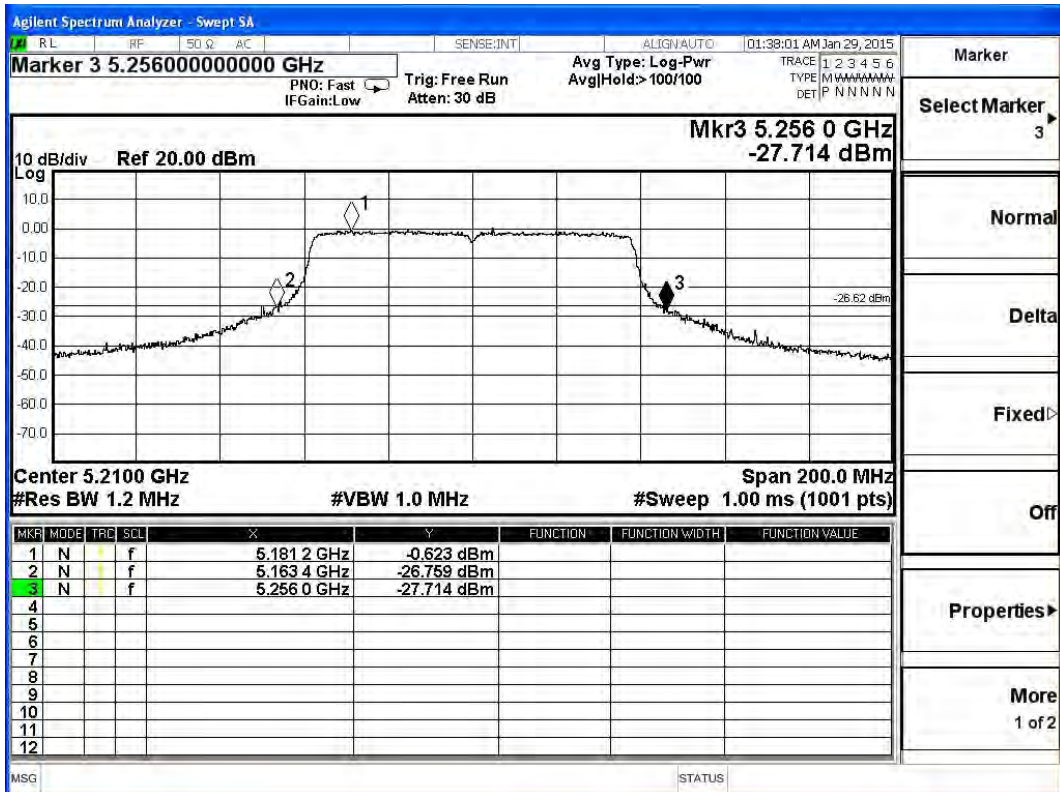

Channel 58 – Chain A

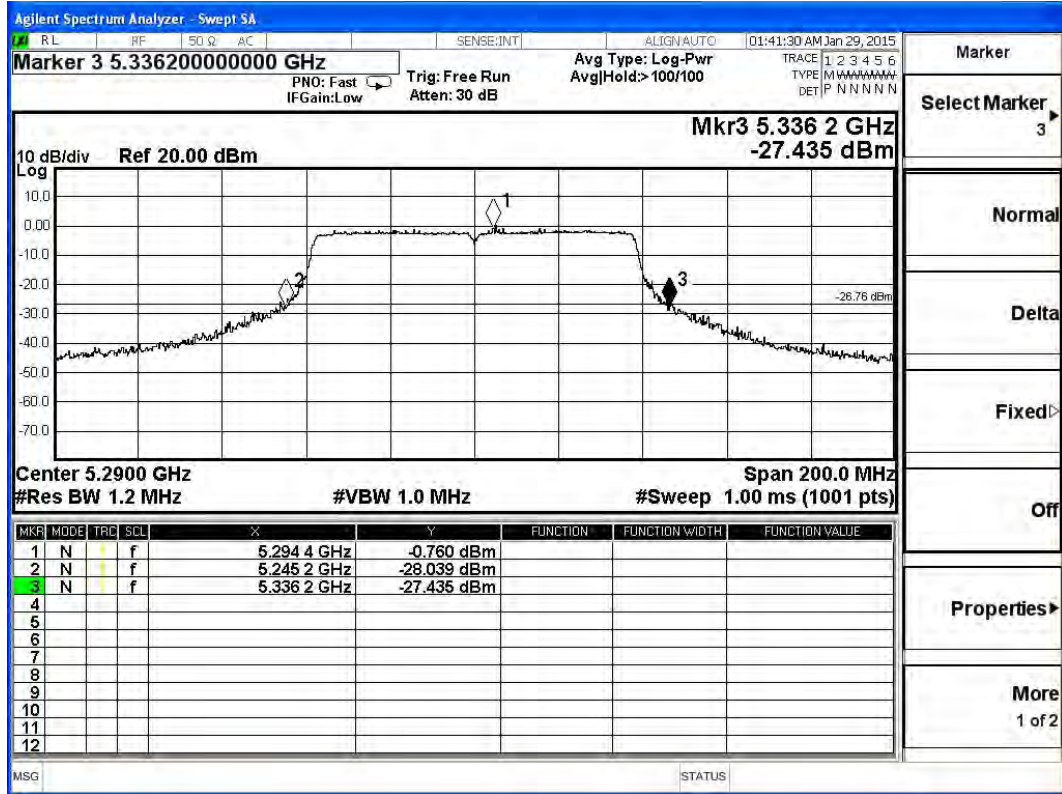

Channel 58 – Chain B

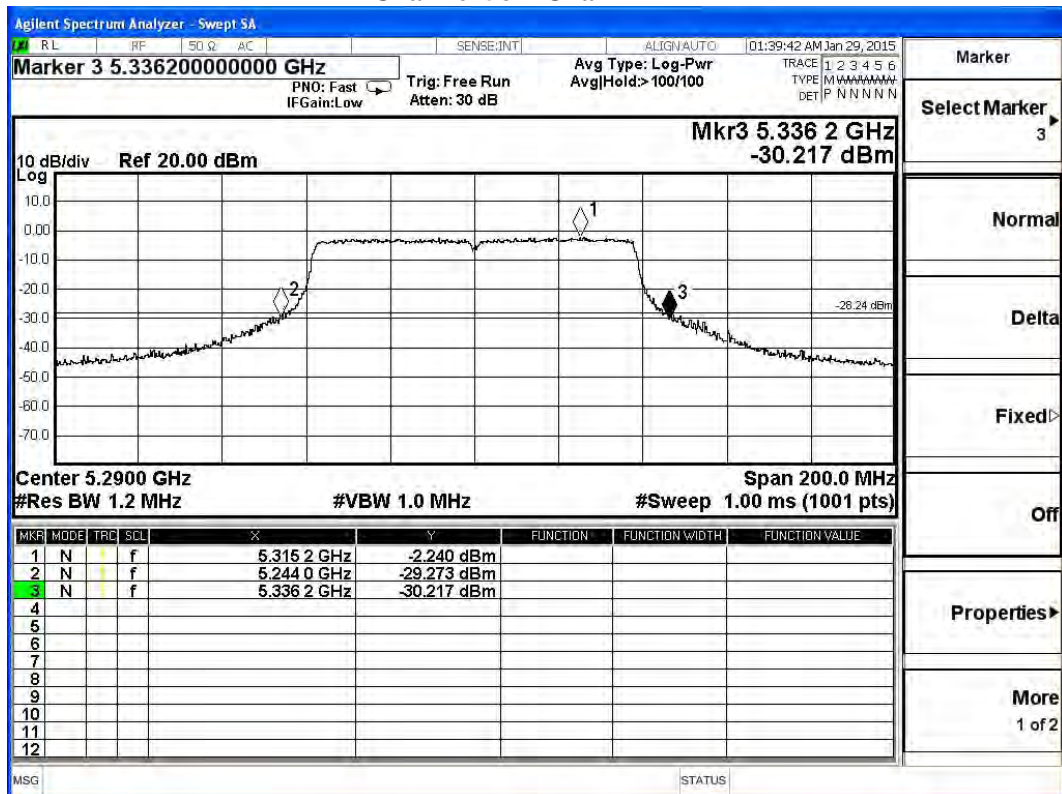

Channel 106 – Chain A

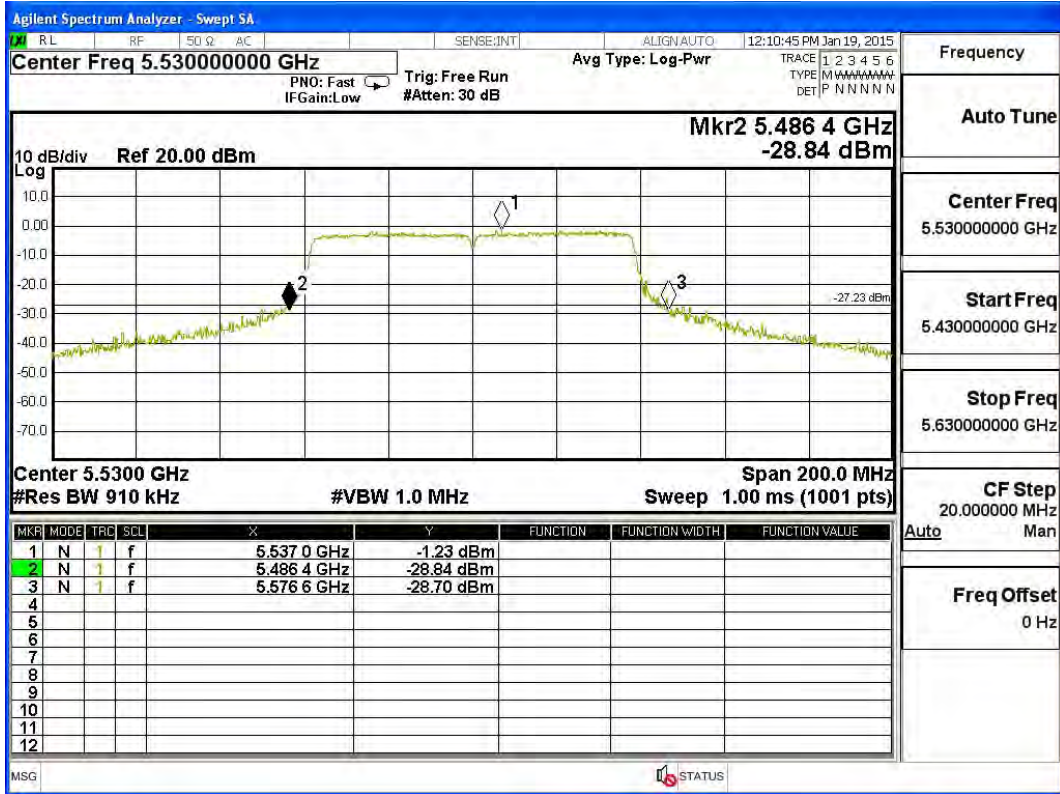

Channel 106 – Chain B

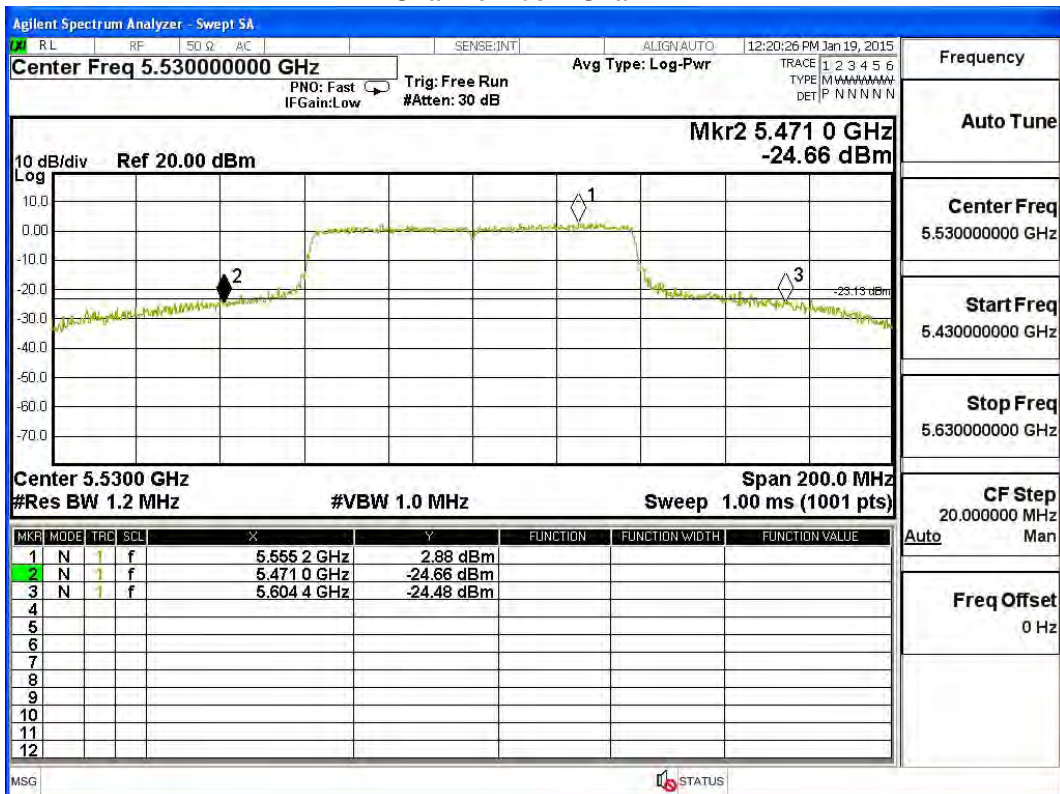

Channel 138 – Chain A

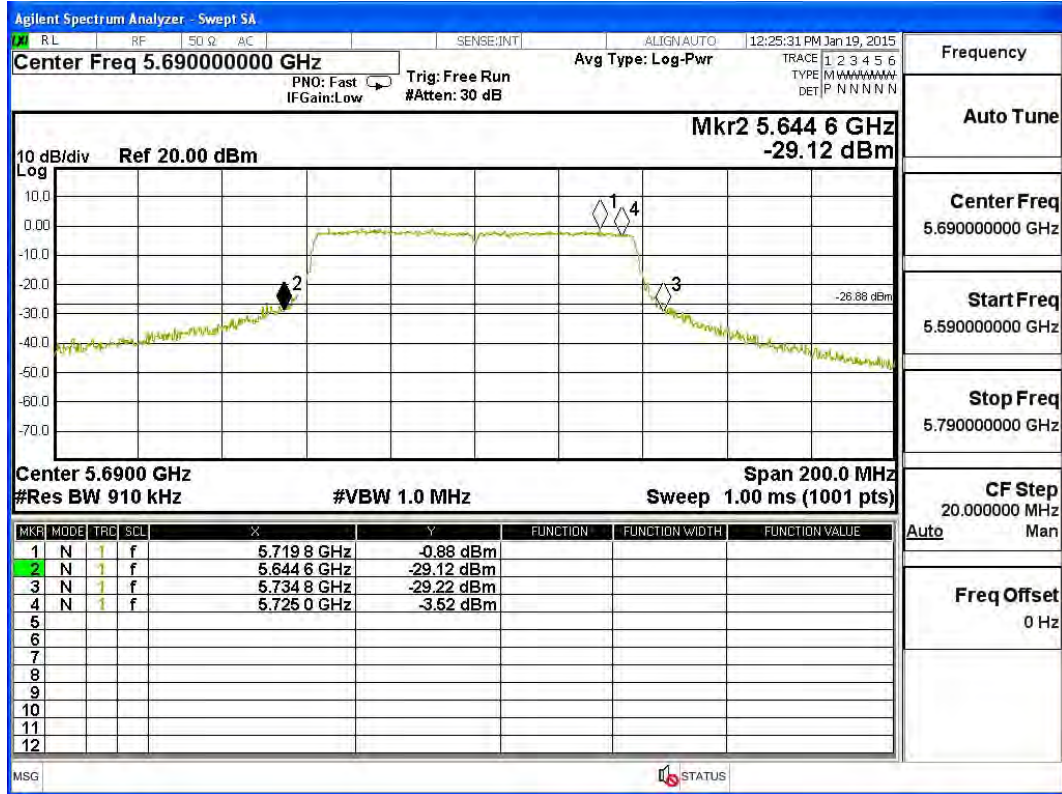

Channel 138 – Chain B

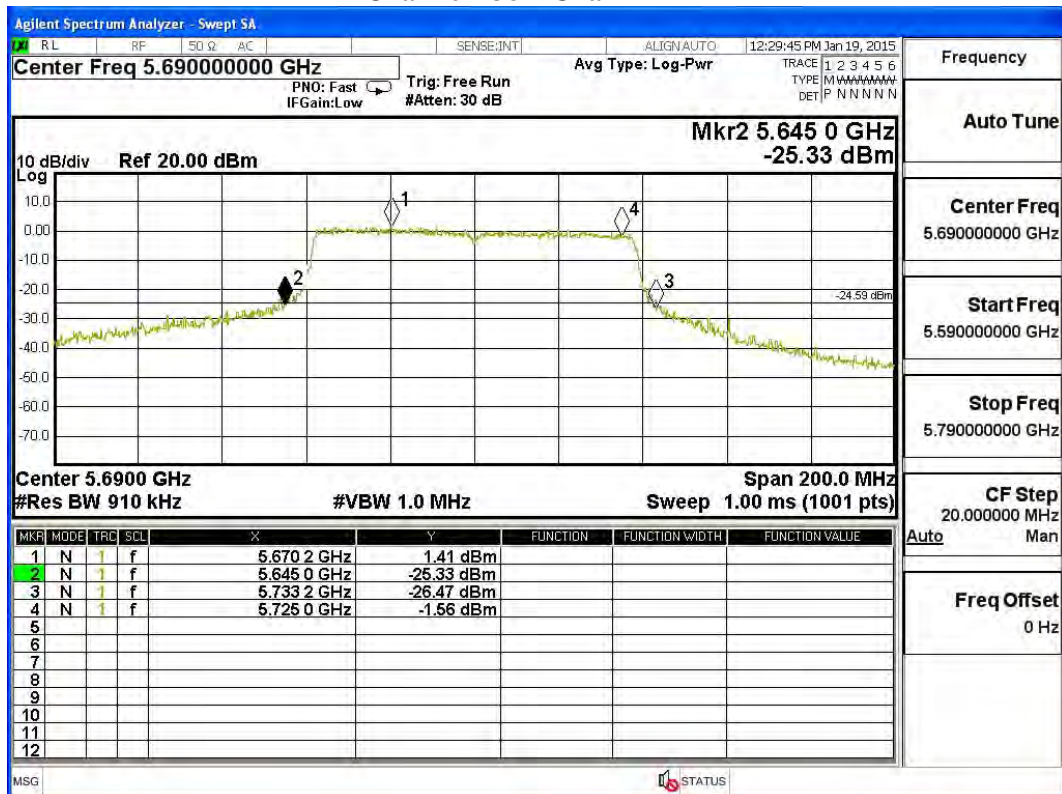

Maximum conducted output power:

Channel 42 – Chain A

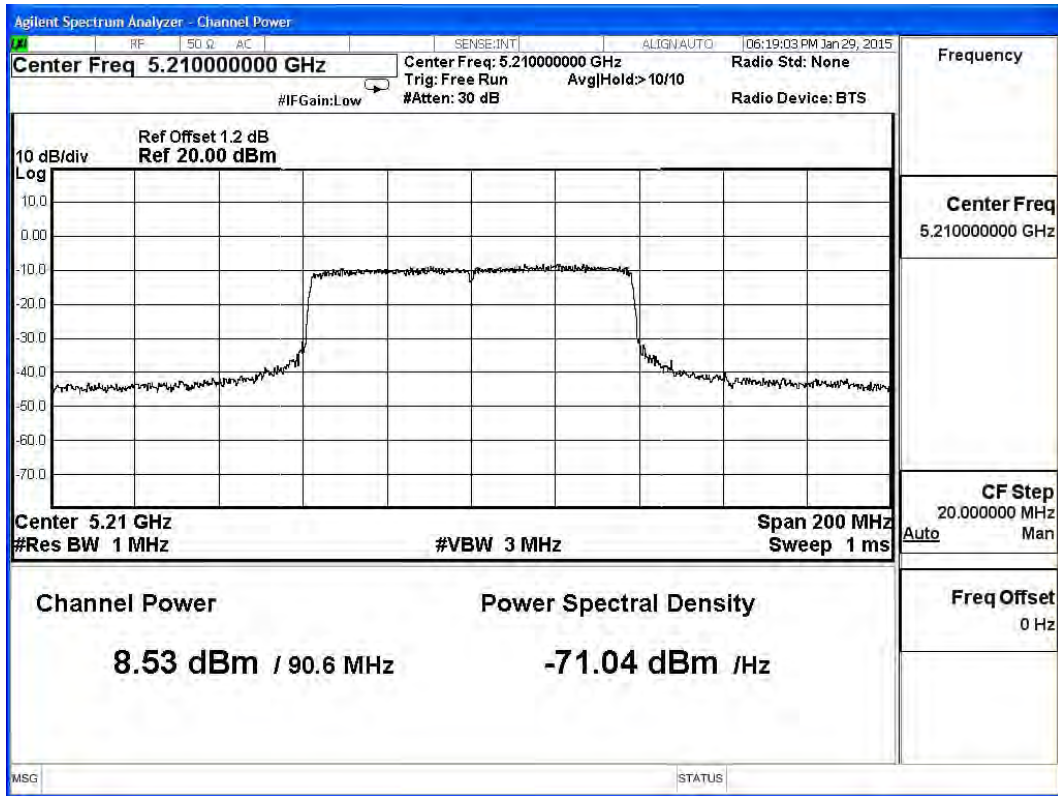

Maximum conducted output power:

Channel 58 – Chain A

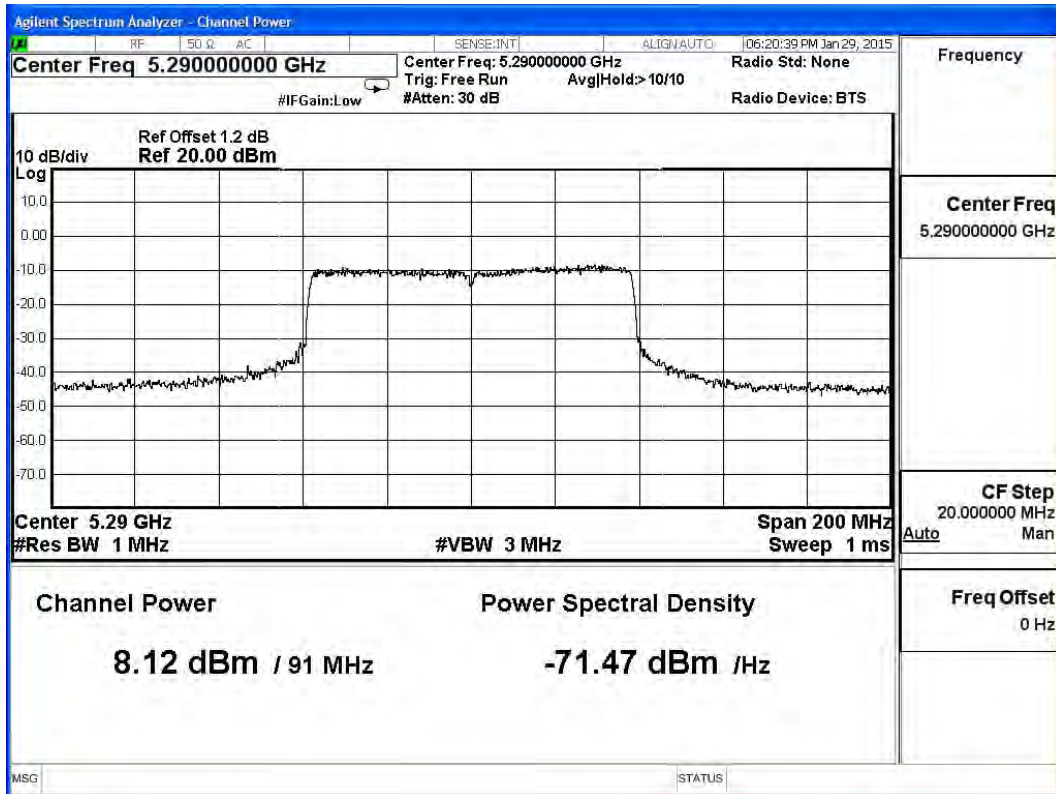

Maximum conducted output power:

Channel 106 – Chain A

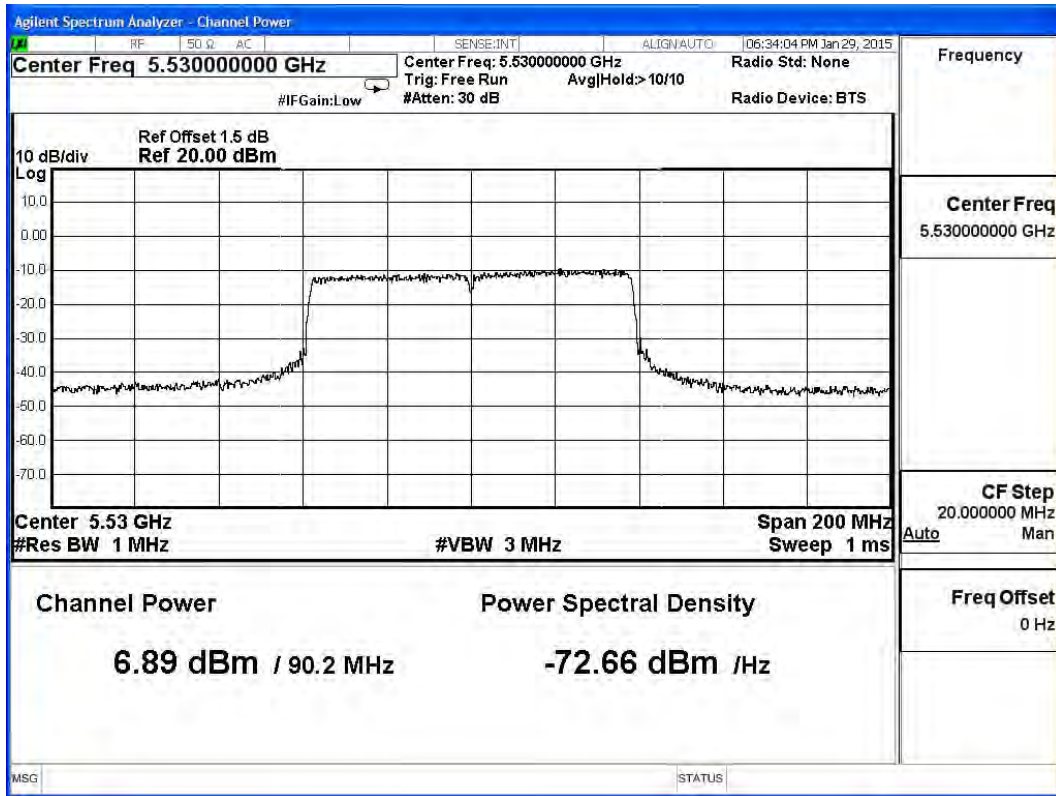

Maximum conducted output power:

Channel 138 (Band3) – Chain A

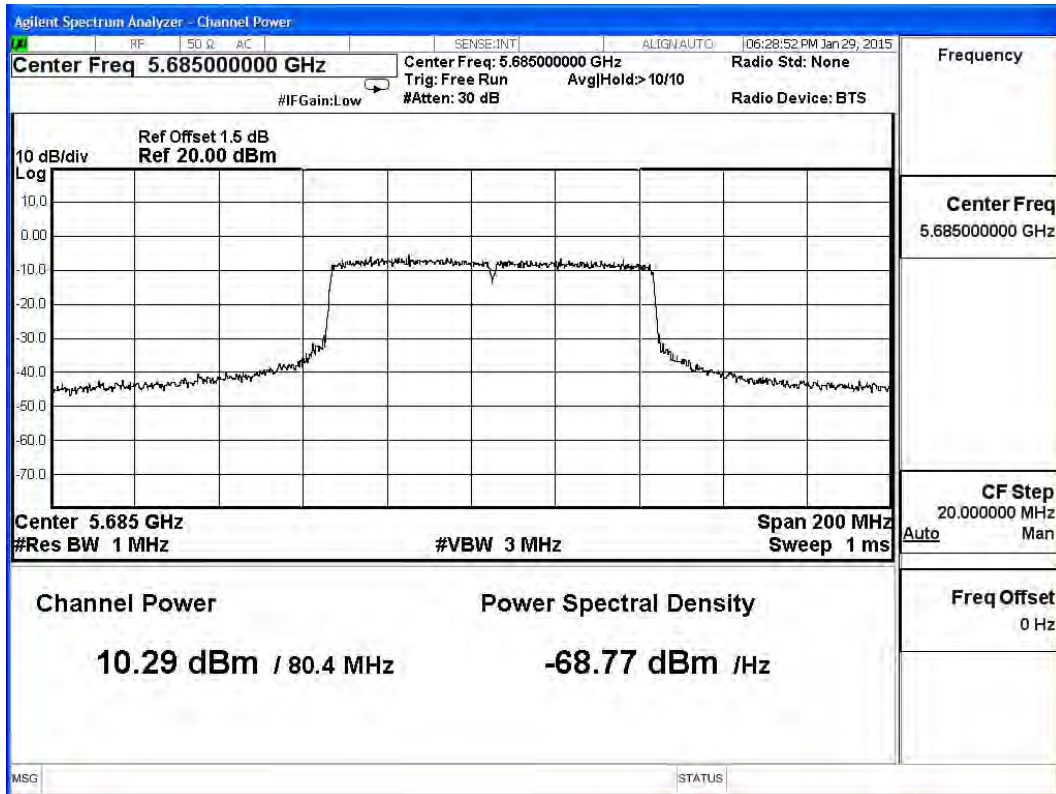

Maximum conducted output power:
Channel 138 (Band4) – Chain A

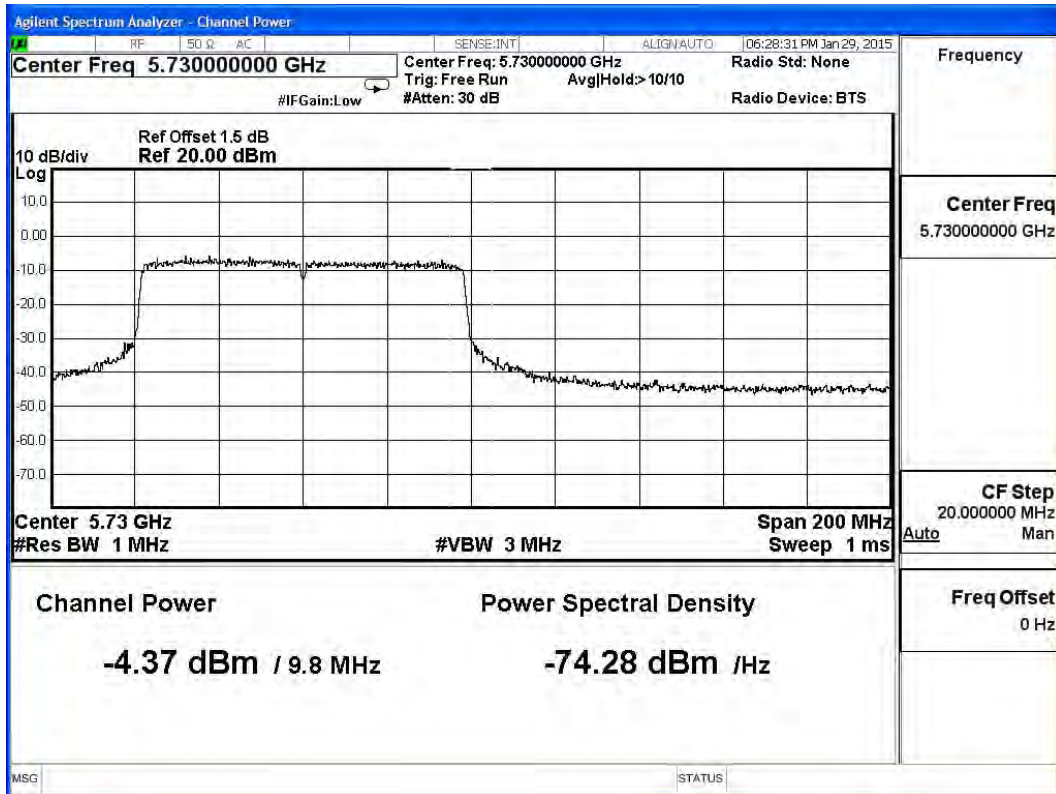

Maximum conducted output power:
Channel 42 – Chain B

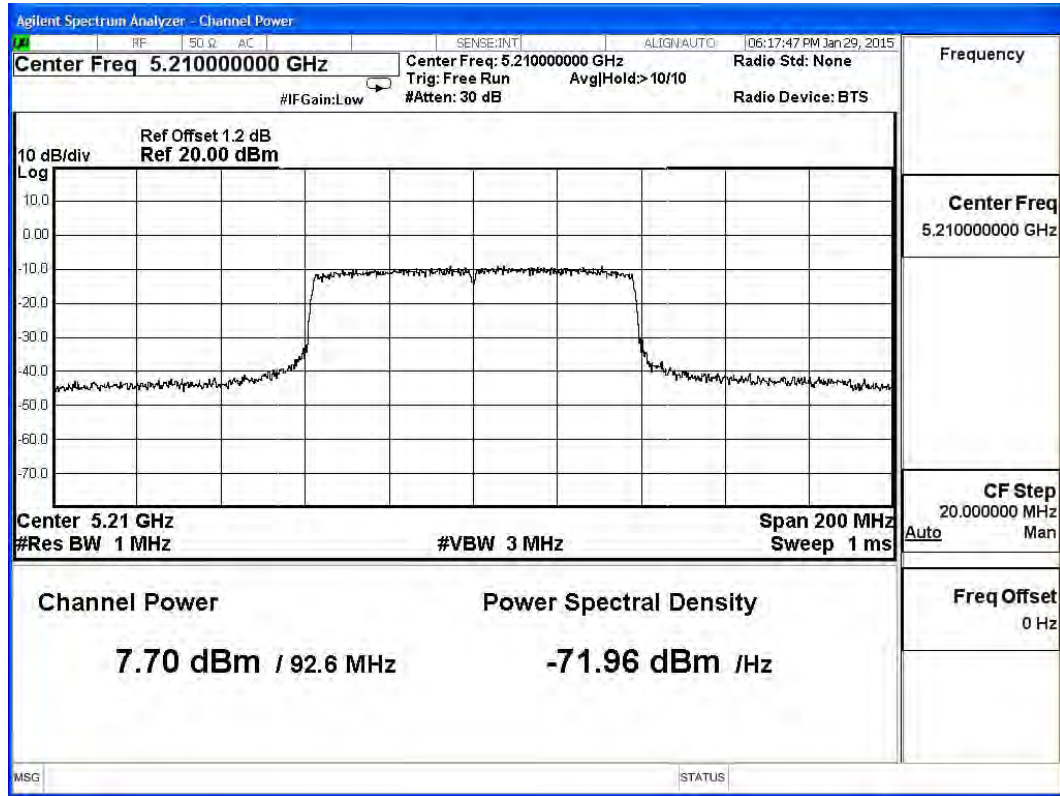

Maximum conducted output power:
Channel 58 – Chain B

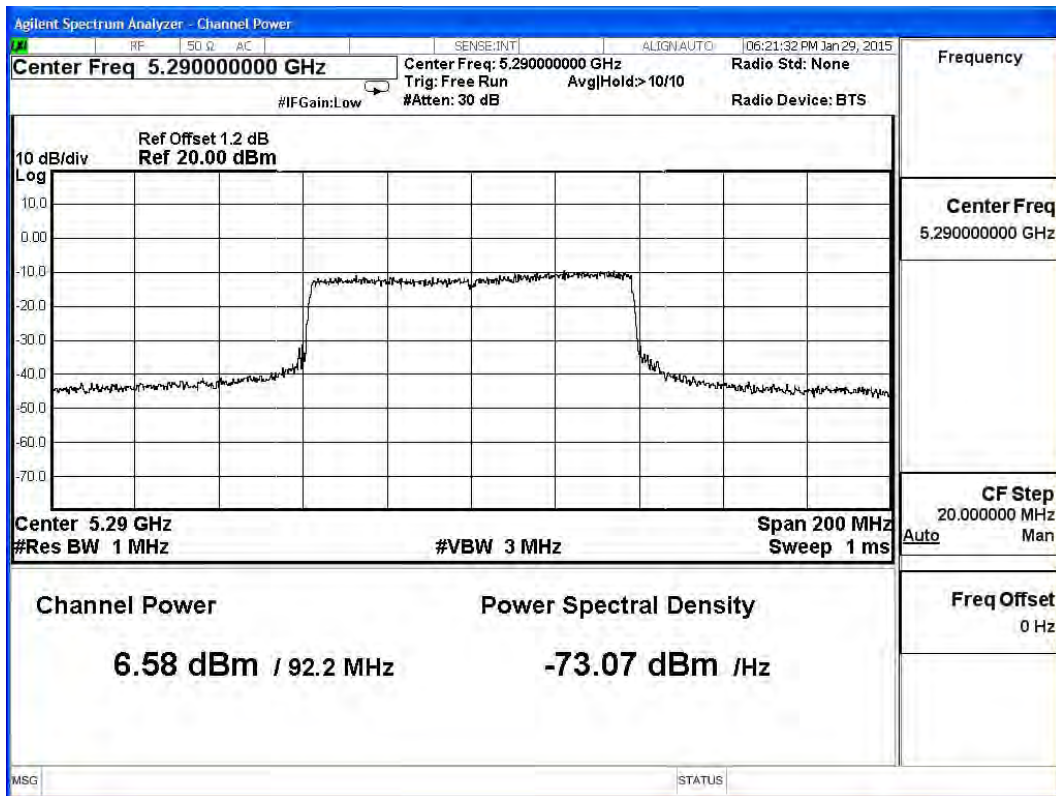

Maximum conducted output power:

Channel 106 – Chain B

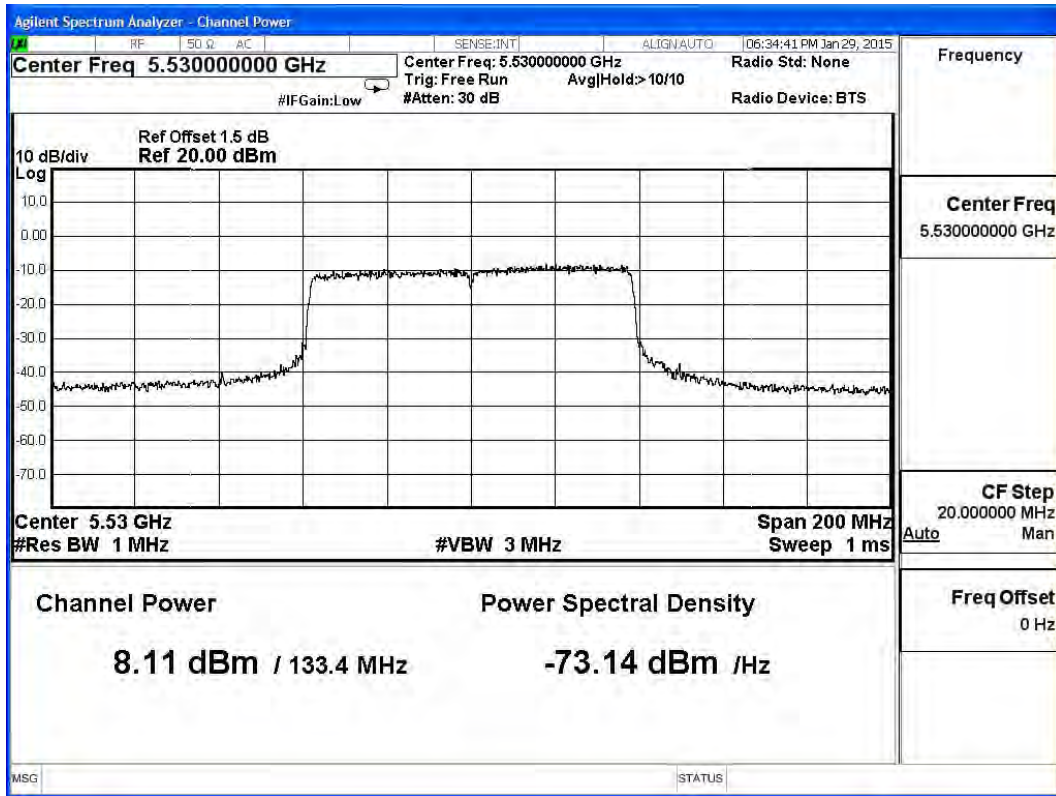

Maximum conducted output power:

Channel 138 (Band3) – Chain B

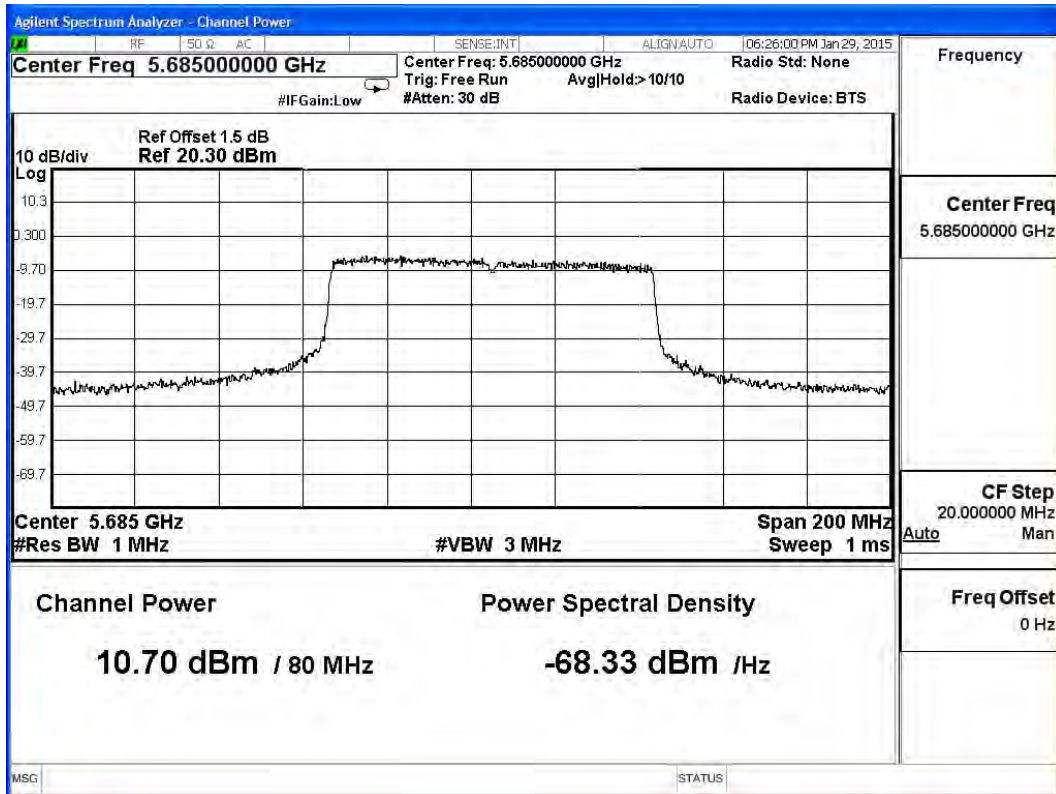

Maximum conducted output power:
 Channel 138 (Band4) – Chain B

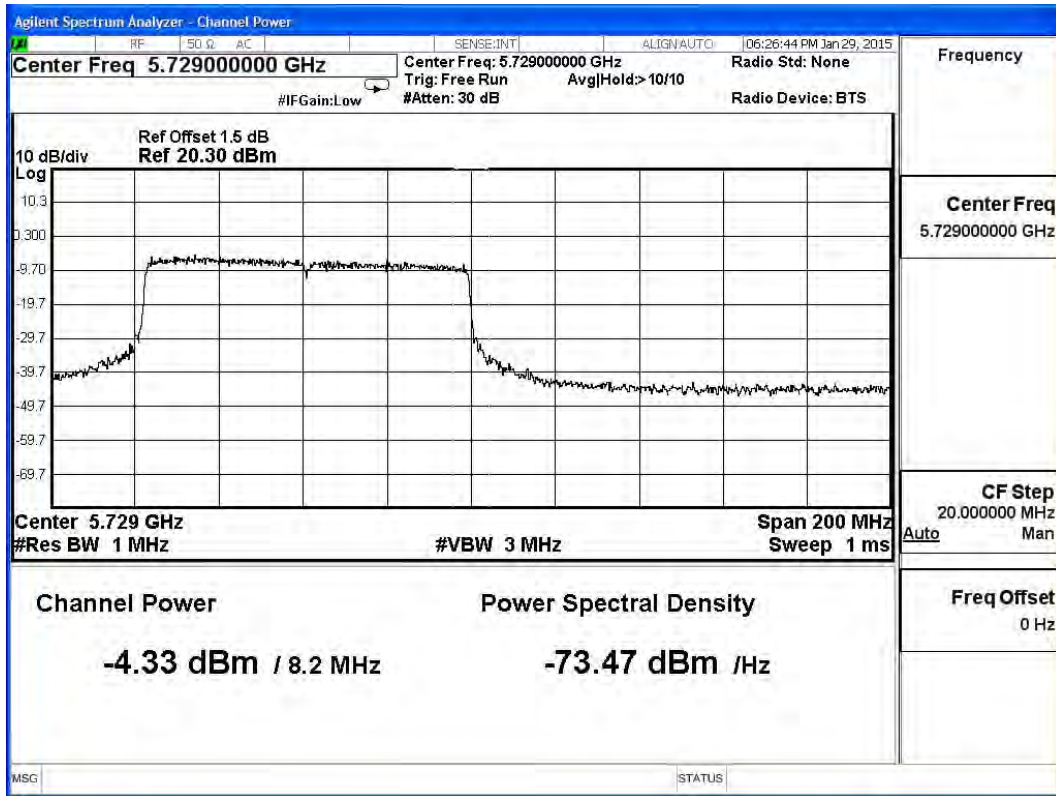

4. Peak Power Spectral Density

4.1. Test Equipment

	Equipment	Manufacturer	Model No./Serial No.	Last Cal.
	Spectrum Analyzer	R&S	FSP40 / 100170	Jun., 2014
	Spectrum Analyzer	Agilent	E4407B / US39440758	Jun., 2014
X	Spectrum Analyzer	Agilent	N9010A / MY48030495	Apr, 2014

Note:

1. All equipments are calibrated with traceable calibrations. Each calibration is traceable to the national or international standards.
2. The test instruments marked with “X” are used to measure the final test results.

4.2. Test Setup

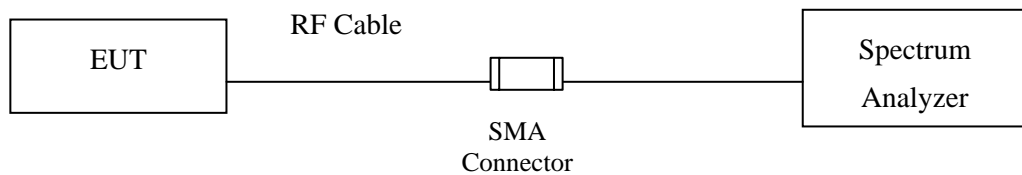

4.3. Limits

- (1) For the band 5.15-5.25 GHz, the peak power spectral density shall not exceed 4 dBm in any 1-MHz band. If transmitting antenna of directional gain greater than 6 dBi are used, the peak power spectral density shall be reduced by the amount in dB that directional gain of the antenna exceeds 6 dBi.
- (2) For the band 5.25-5.35 GHz, the peak power spectral density shall not exceed 11 dBm in any 1-MHz band. If transmitting antenna of directional gain greater than 6 dBi are used, the peak power spectral density shall be reduced by the amount in dB that directional gain of the antenna exceeds 6 dBi.
- (3) For the band 5.725-5.825 GHz, the peak power spectral density shall not exceed 17 dBm in any 1-MHz band. If transmitting antenna of directional gain greater than 6 dBi are used, the peak power spectral density shall be reduced by the amount in dB that directional gain of the antenna exceeds 6 dBi.

4.4. Test Procedure

The EUT was setup to ANSI C63.10: 2009; tested to DTS test procedure of FCC KDB-789033 for compliance to FCC 47CFR Subpart E requirements.

The Peak Power Spectral Density using KDB 789033 section F) procedure, Create an average power spectrum for the EUT operating mode being tested by following the instructions in section E)2) for measuring maximum conducted output power using a spectrum analyzer.

SA-1 method is selected to run the test.

4.5. Uncertainty

± 1.27 dB

4.6. Test Result of Peak Power Spectral Density

Product : Wireless Access Point
 Test Item : Peak Power Spectral Density
 Test Site : No.3 OATS
 Test Mode : Mode 1: Transmit (802.11a-6Mbps) (Internal Antenna)

Channel Number	Frequency (MHz)	Data Rata (Mbps)	Reading Level (dBm)	Cable Loss (dB)	Measurement Level (dBm)	Required Limit (dBm)	Result
36	5180	6	-6.18	1.2	-4.98	4	Pass
44	5220	6	-5.90	1.2	-4.70	4	Pass
48	5240	6	-5.27	1.2	-4.07	4	Pass
52	5260	6	-5.26	1.2	-4.06	11	Pass
60	5300	6	-4.30	1.2	-3.10	11	Pass
64	5320	6	-3.64	1.2	-2.44	11	Pass
100	5500	6	-2.36	1.5	-0.86	11	Pass
116	5580	6	-2.04	1.5	-0.54	11	Pass
140	5700	6	-3.45	1.5	-1.95	11	Pass

Channel 36:

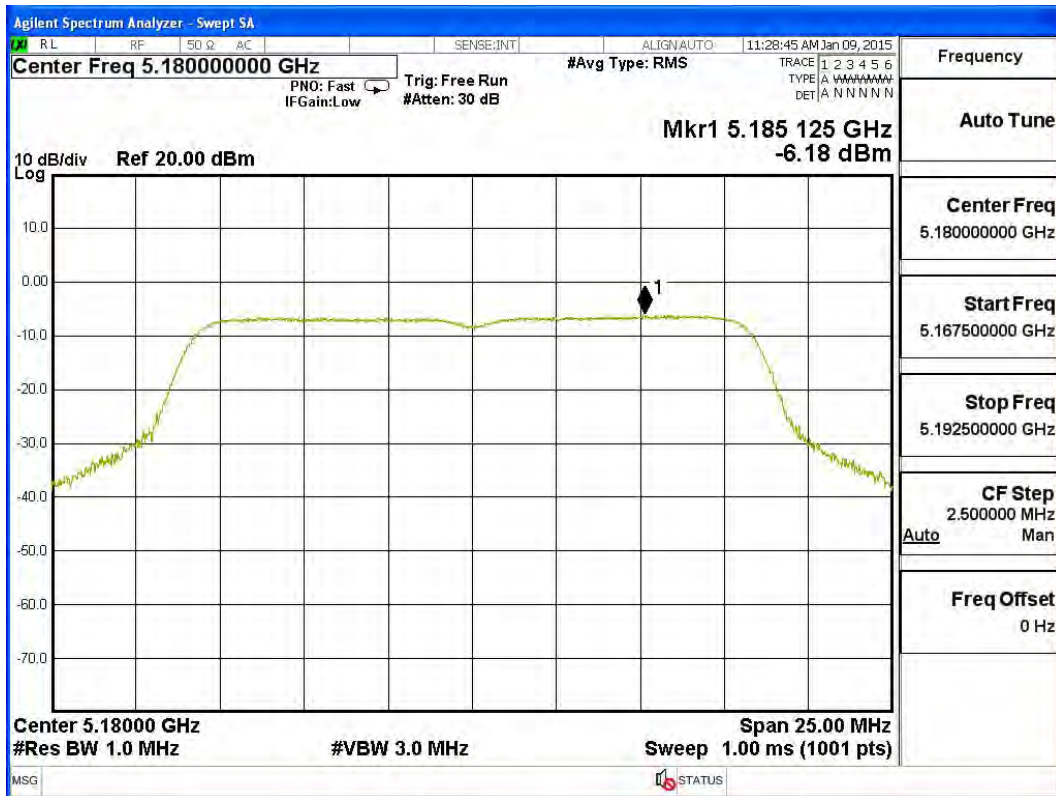

Channel 44:

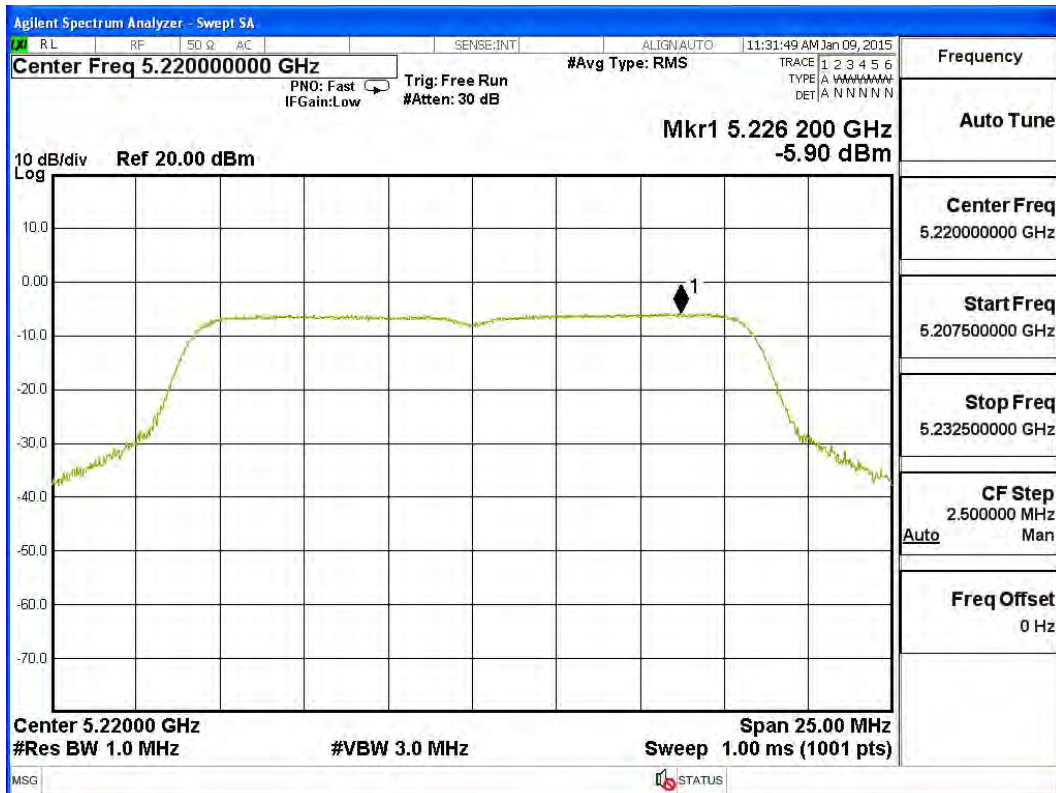

Channel 48:



Channel 52:

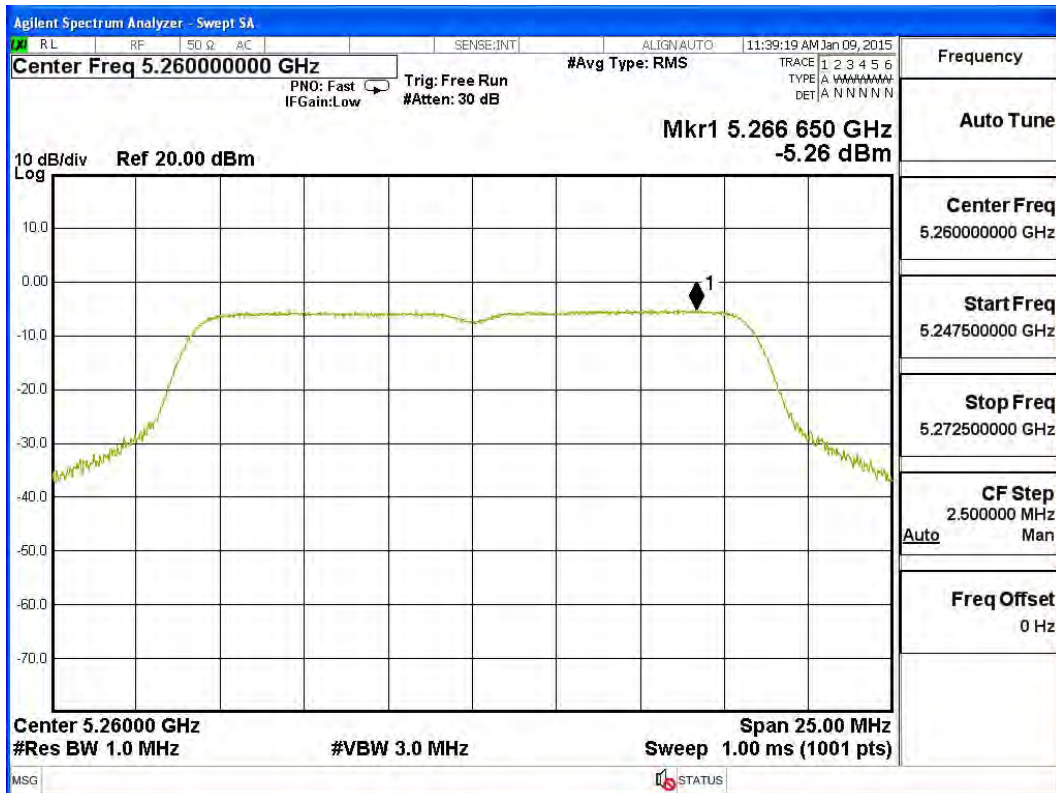

Channel 60:

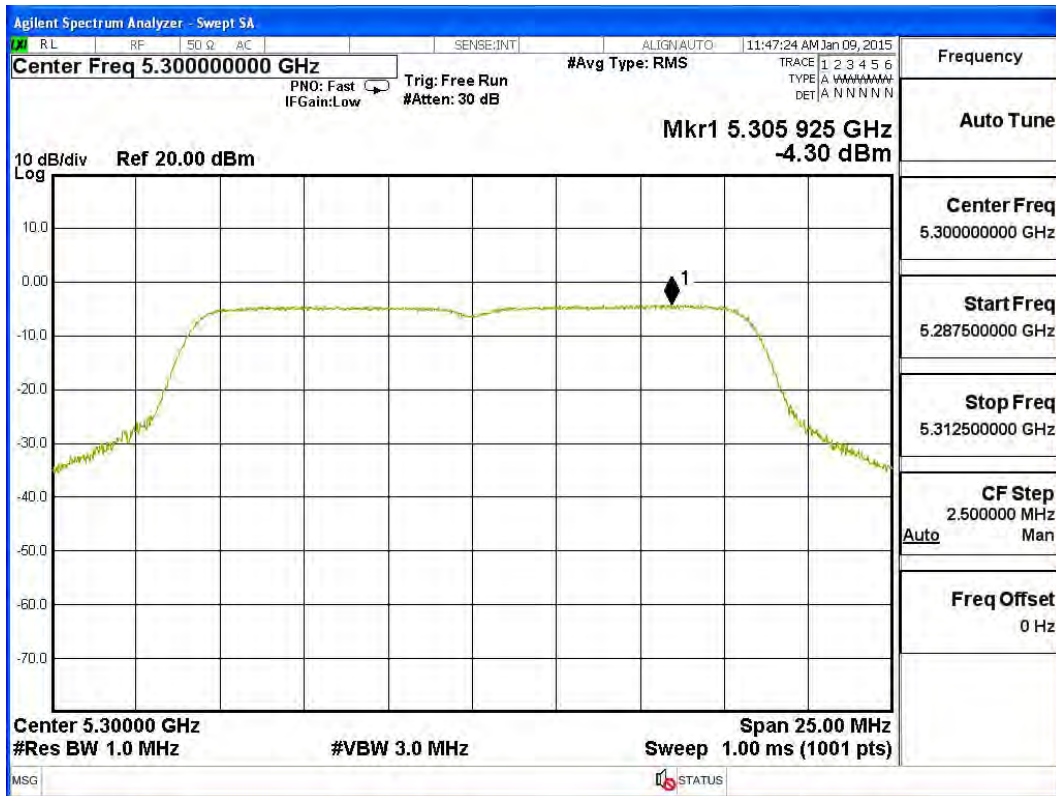

Channel 64:

