

ENGINEERING TEST REPORT

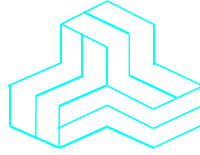

**HF/VHF/UHF All Mode Transceiver
Model No.: IC-7100**

FCC ID: AFJ339300

Applicant:

ICOM Incorporated
1-1-32, Kamiminami, Hirano-ku
Osaka, Japan, 547-0003

Tested in Accordance With

**Federal Communications Commission (FCC)
47 CFR, Part 15, Subpart B, Scanning Receivers**

UltraTech's File No.: 16ICOM416Q_FCC15B121

This Test report is Issued under the Authority of
Tri M. Luu, BAsC
Vice President of Engineering
UltraTech Group of Labs

Date: March 14, 2016

Report Prepared by: Dharmajit Solanki

Tested by: Wei Wu and Hien Luu

Issued Date: March 14, 2016

Test Dates: March 8 - 10, 2016

- *The results in this Test Report apply only to the sample(s) tested, and the sample tested is randomly selected.*
- *This report must not be used by the client to claim product endorsement by NVLAP or any agency of the US Government.*

UltraTech

3000 Bristol Circle, Oakville, Ontario, Canada, L6H 6G4
Tel.: (905) 829-1570 Fax.: (905) 829-8050

Website: www.ultratech-labs.com, Email: vic@ultratech-labs.com, Email: tri@ultratech-labs.com



91038



1309



46390-2049



NVLAP LAB
CODE 200093-0



AT-1945



SL2-IN-E-
1119R



CA2049



TL363_B



TPTDP
DA1300

TABLE OF CONTENTS

EXHIBIT 1. INTRODUCTION	1
1.1. SCOPE.....	1
1.2. RELATED SUBMITTAL(S)/GRANT(S)	1
1.3. NORMATIVE REFERENCES	1
EXHIBIT 2. PERFORMANCE ASSESSMENT	2
2.1. CLIENT INFORMATION.....	2
2.2. EQUIPMENT UNDER TEST (EUT) INFORMATION	2
2.3. EUT'S TECHNICAL SPECIFICATIONS	3
2.4. LIST OF EUT'S PORTS.....	3
2.5. ANCILLARY EQUIPMENT.....	3
EXHIBIT 3. EUT OPERATING CONDITIONS AND CONFIGURATIONS DURING TESTS.....	5
3.1. OPERATIONAL TEST CONDITIONS & ARRANGEMENT FOR TEST SIGNALS.....	5
EXHIBIT 4. SUMMARY OF TEST RESULTS.....	6
4.1. LOCATION OF TESTS.....	6
4.2. APPLICABILITY & SUMMARY OF EMC EMISSION TEST RESULTS	6
4.3. MODIFICATIONS REQUIRED FOR COMPLIANCE.....	6
EXHIBIT 5. MEASUREMENTS, EXAMINATIONS & TEST DATA FOR EMC EMISSIONS.....	7
5.1. TEST PROCEDURES.....	7
5.2. MEASUREMENT UNCERTAINTIES	7
5.3. MEASUREMENT EQUIPMENT USED	7
5.4. RECEIVER ANTENNA POWER SPURIOUS/HARMONIC CONDUCTED EMISSIONS [§15.111(A)]	8
5.5. SPURIOUS/HARMONIC RADIATED EMISSIONS FROM RECEIVER AND CLASS B UNINTENTIONAL RADIATORS (DIGITAL DEVICES) [§ 15.109(A)]	21
EXHIBIT 6. TEST EQUIPMENTS LIST	25
EXHIBIT 7. MEASUREMENT UNCERTAINTY.....	26
7.1. LINE CONDUCTED EMISSION MEASUREMENT UNCERTAINTY	26
7.2. RADIATED EMISSION MEASUREMENT UNCERTAINTY	26

EXHIBIT 1. INTRODUCTION

1.1. SCOPE

Reference:	FCC Part 15, Subpart B, Sections 15.107, 15.109, 15.111 & 15.121
Title:	Code of Federal Regulations (CFR), Title 47, Telecommunication, Part 15
Purpose of Test:	To gain FCC Class II Permissive Change Request Authorization for Scanning Receiver
Test Procedures:	Both conducted and radiated emissions measurements were conducted in accordance with American National Standards Institute ANSI C63.4 - American National Standard for Methods of Measurement of Radio-Noise Emissions from Low-Voltage Electrical and Electronic Equipment in the Range of 9 kHz to 40 GHz
Environmental Classification:	Residential, Commercial, Industrial or Business environments

1.2. RELATED SUBMITTAL(S)/GRANT(S)

None

1.3. NORMATIVE REFERENCES

Publication	Year	Title
FCC CFR Parts 0-19, 80-End	2016	Code of Federal Regulations – Telecommunication
ANSI C63.4	2014	American National Standard for Methods of Measurement of Radio-Noise Emissions from Low-Voltage Electrical and Electronic Equipment in the Range of 9 kHz to 40 GHz
ANSI C63.10	2013	American National Standard for Testing Unlicensed Wireless Devices
TIA/EIA 603, Edition D	2009	Land Mobile FM or PM Communications Equipment Measurement and Performance Standards

EXHIBIT 2. PERFORMANCE ASSESSMENT

2.1. CLIENT INFORMATION

APPLICANT	
Name:	Icom Incorporated
Address:	1-1-32, Kamiminami, Hirano-ku, Osaka Japan, 547-0003
Contact Person:	Mr. Hideji Fujishima Phone #: +81-66-793-8424 Fax #: +81-66-793-3336 Email Address: world_support@icom.co.jp

MANUFACTURER	
Name:	Icom Incorporated
Address:	1-1-32, Kamiminami Hirano-ku, Osaka Japan, 547-0003
Contact Person:	Mr. Hideji Fujishima Phone #: +81-66-793-8424 Fax #: +81-66-793-3336 Email Address: world_support@icom.co.jp

2.2. EQUIPMENT UNDER TEST (EUT) INFORMATION

The following information (with the exception of the Date of Receipt) has been supplied by the applicant.

Brand Name:	ICOM Incorporated
Product Name:	HF/VHF/UHF All Mode Transceiver
Model Name or Number:	IC-7100
Serial Number:	02006300
Type of Equipment:	Amateur Radio & Scanning Receiver
Power Input Source:	13.8V DC \pm 15%

2.3. EUT'S TECHNICAL SPECIFICATIONS

RECEIVER	
Equipment Type:	Mobile or Fixed
Power Supply Requirement:	13.8V DC \pm 15%
Operating Frequency Range:	0.03 - 199.999 MHz 400.00 - 470.00 MHz
RF Input Impedance:	50 Ω

2.4. LIST OF EUT'S PORTS

Port Number	EUT's Port Description	Number of Identical Ports	Connector Type	Cable Type (Shielded/Non-shielded)
1	Antenna Connectors [ANT1 & 2]	2	UHF Female	Shielded
2	Ext Speaker [SP]	1	2 Pin Jack	Non-Shielded
3	Microphone [MIC]	1	RJ45	Non-Shielded
4	DC IN JACK [DC IN]	1	Plug-In Jack	Non-Shielded
5	Tuner	1	Plug-In Jack	Non-Shielded
6	Controller	1	RJ45	Non-Shielded
7	DATA Jacks [DATA1 & 2]	1 each	Mini Jack & 6-Pin Din	Shielded
8	ACC Jack	1	13-Pin Din	Shielded
9	Remote & Key Jacks	1 each	Mini Jack	Shielded
10	USB	1	Micro USB	Shielded
11	Phones/SP	1	Mini Jack	Shielded
12	Elec Key	1	Mini Jack	Shielded

2.5. ANCILLARY EQUIPMENT

The EUT was tested while connected to the following representative configuration of ancillary equipment necessary to exercise the ports during tests:

Ancillary Equipment # 1	
Description:	External Microphone
Brand name:	ICOM
Model Name or Number:	HM-198
Cable Type:	Non-Shielded

Ancillary Equipment # 2	
Description:	D-Star Display Controller
Brand name:	ICOM
Model Name or Number:	IC-7100
Cable Type:	Shielded

Ancillary Equipment # 3	
Description:	External Speaker
Brand name:	ICOM
Model Name or Number:	SP-35L
Cable Type:	Non-Shielded

Ancillary Equipment # 4	
Description:	Headphone
Brand name:	Sony
Model Name or Number:	MDR-2500
Cable Type:	Non-Shielded

EXHIBIT 3. EUT OPERATING CONDITIONS AND CONFIGURATIONS DURING TESTS

3.1. CLIMATE TEST CONDITIONS

The climate conditions of the test environment are as follows:

Temperature:	21 - 24°C
Humidity:	40-56%
Pressure:	101 -102 kPa
Power input source:	13.8V DC \pm 15%

3.2. OPERATIONAL TEST CONDITIONS & ARRANGEMENT FOR TEST SIGNALS

Operating Modes:	The receiver was operated in the normal intended mode during testing
Special Test Software:	None
Special Hardware Used:	None
Receiver Test Antenna:	The EUT was tested with its antenna port terminated to 50 Ω

Receiver Test Signals	
Frequency Band(s):	0.03 - 199.999 MHz 400.00 - 470.00 MHz
Test Frequency(ies): (Near lowest, near middle & near highest frequencies in the frequency range of operation.)	30 MHz, 144.0 MHz, 199.9 MHz and 400 MHz, 435 MHz, 470 MHz

EXHIBIT 4. SUMMARY OF TEST RESULTS

4.1. LOCATION OF TESTS

All of the measurements described in this report were performed at Ultratech Group of Labs located in the city of Oakville, Province of Ontario, Canada.

- AC Power Line Conducted Emissions were performed in UltraTech's shielded room, 24'(L) by 16'(W) by 8'(H).
- Radiated Emissions were performed at the Ultratech's 3-10 TDK Semi-Anechoic Chamber situated in the Town of Oakville, province of Ontario. This test site been calibrated in accordance with ANSI C63.4, and found to be in compliance with the requirements of Sec. 2.948 of the FCC Rules. The descriptions and site measurement data of the Oakville 3-10 TDK Semi-Anechoic Chamber has been filed with FCC office (FCC File No.: 91038) and Industry Canada office (Industry Canada File No.: 2049A-3). Expiry Date: 2017-04-02.

4.2. APPLICABILITY & SUMMARY OF EMC EMISSION TEST RESULTS

FCC Part 15, Subpart B	Test Requirements	Compliance (Yes/No)
15.107(a), Class B	Power Line Conducted Emissions Measurements	N/A*
15.111(a)	Receiver Antenna Power Conducted Emissions for Non-Integral Antenna Port	Yes
15.109(a)	Radiated Emissions from Scanning Receivers & Class B Digital Device	Yes
15.121	Requirements for Scanning Receivers	N/A*

*Not affected due to the modifications performed by the applicant.

4.3. MODIFICATIONS REQUIRED FOR COMPLIANCE

None

EXHIBIT 5. MEASUREMENTS, EXAMINATIONS & TEST DATA FOR EMC EMISSIONS

5.1. TEST PROCEDURES

Please refer to Ultratech Test Procedures, File# ULTR-P001-2004 and for Test Procedures.

5.2. MEASUREMENT UNCERTAINTIES

The measurement uncertainties stated were calculated in accordance with the requirements of CISPR 16-4-2 @ IEC:2003 and JCGM 100:2008 (GUM 1995) – Guide to the Expression of Uncertainty in Measurement. Please refer to Exhibit 7 for Measurement Uncertainties.

5.3. MEASUREMENT EQUIPMENT USED

The measurement equipment used complied with the requirements contained in ANSI C63.10 and CISPR 16-1-1.

5.4. RECEIVER ANTENNA POWER SPURIOUS/HARMONIC CONDUCTED EMISSIONS [§ 15.111(a)]

5.4.1. Limits

Receivers that operate (tune) in the frequency range 30 to 960 MHz and CB receivers that provides terminals for the connection of an external antenna may be tested to demonstrate compliance with the provisions of @ 15.109 with the antenna terminals shielded and terminated with a resistive termination equal to the impedance specified for the antenna, provided these receivers also comply with the following:- With the receiver antenna terminal connected to a resistive termination equal to the impedance specified or employed for the antenna, the power at the antenna terminal at frequency within the range from 30 MHz to 5th harmonic of the highest frequency shall not exceed 2.0 nanowatts (or -57 dBm @ 50 Ohm).

5.4.2. Method of Measurements

Refer to Ultratech Test Procedures ULTR-P001-200 & ANSI C63.4 for method of measurements.

The spectrum shall be investigated from the lowest radio frequency signal generated or used in the device, without going below the lowest frequency for which the emission limit is specified, up to 5th harmonic of the highest frequency.

5.4.3. Test Arrangement

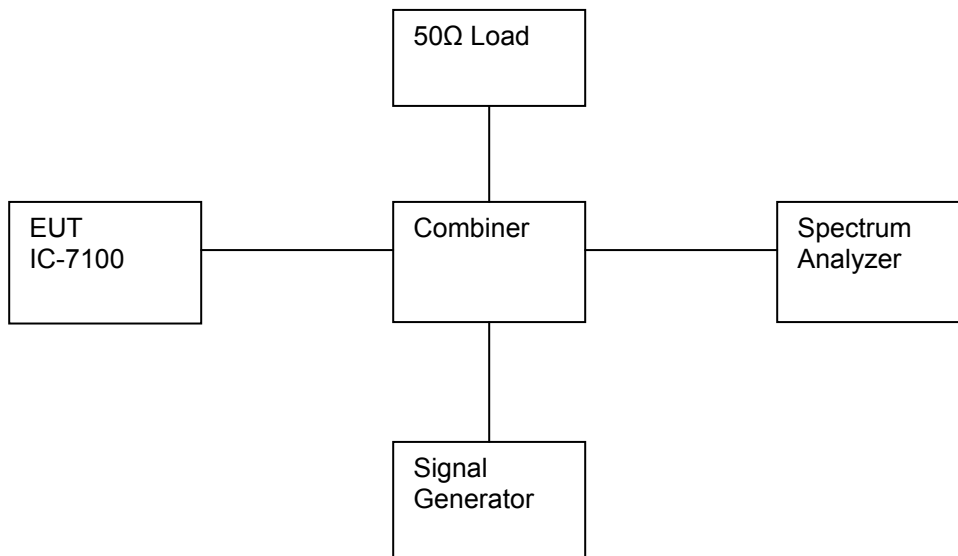

5.4.4. Test Data

ULTRATECH GROUP OF LABS

3000 Bristol Circle, Oakville, Ontario, Canada L6H 6G4
Tel. #: 905-829-1570, Fax. #: 905-829-8050, Email: vic@ultratech-labs.com, Website: <http://www.ultratech-labs.com>

File #: 16ICOM416Q_FCC15B121

March 14, 2016

All test results contained in this engineering test report are traceable to National Institute of Standards and Technology (NIST)

5.4.4.1. ANT 1 in Rx Mode

Plot 1: Conducted Receiver Spurious Emissions, 30 MHz – 5 GHz

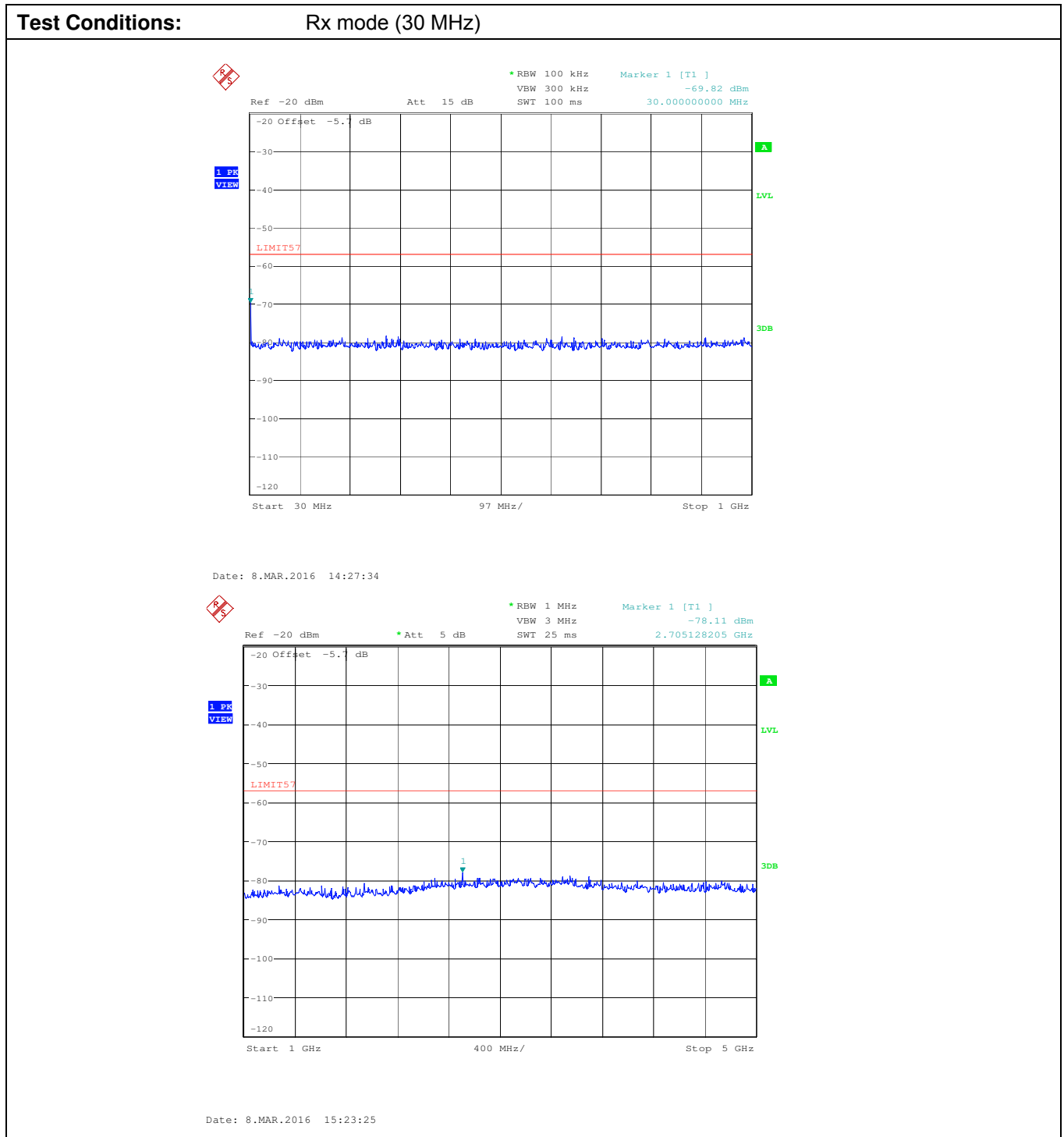

Plot 2: Conducted Receiver Spurious Emissions, 30 MHz – 5 GHz



ULTRATECH GROUP OF LABS

3000 Bristol Circle, Oakville, Ontario, Canada L6H 6G4
Tel. #: 905-829-1570, Fax. #: 905-829-8050, Email: vic@ultratech-labs.com, Website: <http://www.ultratech-labs.com>

File #: 16ICOM416Q_FCC15B121

March 14, 2016

All test results contained in this engineering test report are traceable to National Institute of Standards and Technology (NIST)

Plot 3: Conducted Receiver Spurious Emissions, 30 MHz – 5 GHz

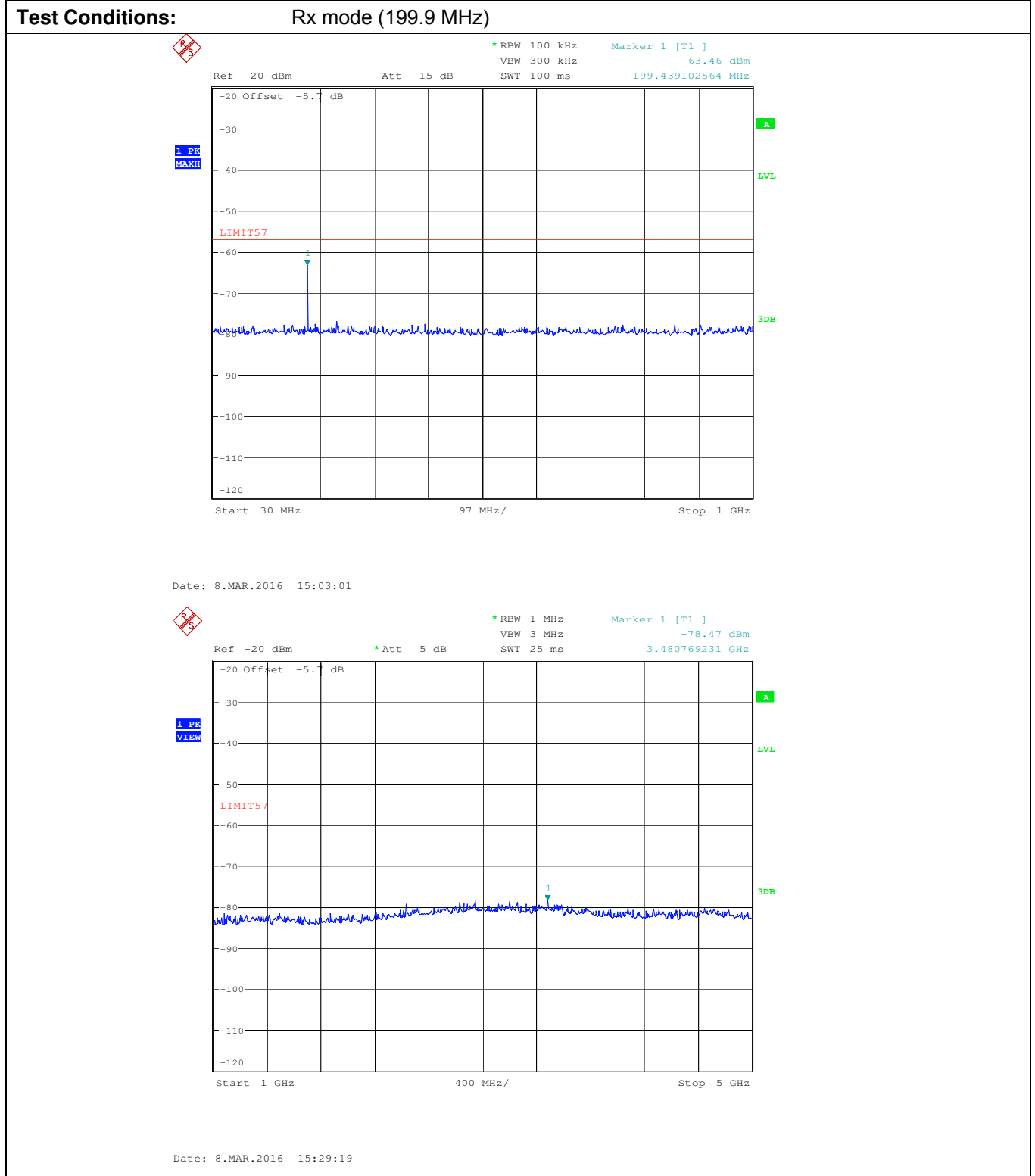

ULTRATECH GROUP OF LABS

3000 Bristol Circle, Oakville, Ontario, Canada L6H 6G4
Tel. #: 905-829-1570, Fax. #: 905-829-8050, Email: vic@ultratech-labs.com, Website: <http://www.ultratech-labs.com>

File #: 16ICOM416Q_FCC15B121

March 14, 2016

All test results contained in this engineering test report are traceable to National Institute of Standards and Technology (NIST)

Plot 4: Conducted Receiver Spurious Emissions, 30 MHz – 5.0 GHz

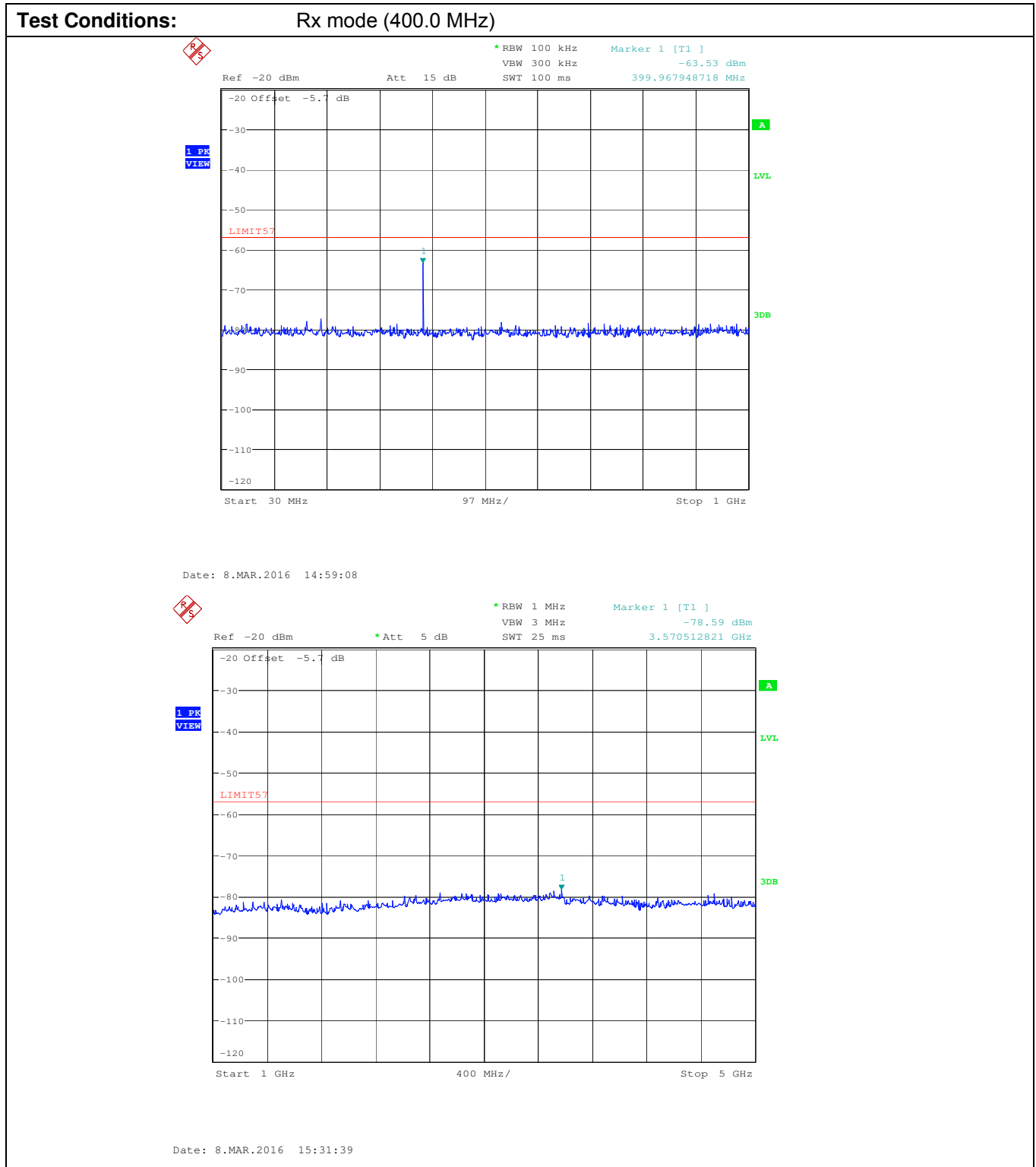

ULTRATECH GROUP OF LABS

3000 Bristol Circle, Oakville, Ontario, Canada L6H 6G4
Tel. #: 905-829-1570, Fax. #: 905-829-8050, Email: vic@ultratech-labs.com, Website: <http://www.ultratech-labs.com>

File #: 16ICOM416Q_FCC15B121

March 14, 2016

All test results contained in this engineering test report are traceable to National Institute of Standards and Technology (NIST)

Plot 5: Conducted Receiver Spurious Emissions, 30 MHz – 5.0 GHz



Plot 6: Conducted Receiver Spurious Emissions, 30 MHz – 5.0 GHz

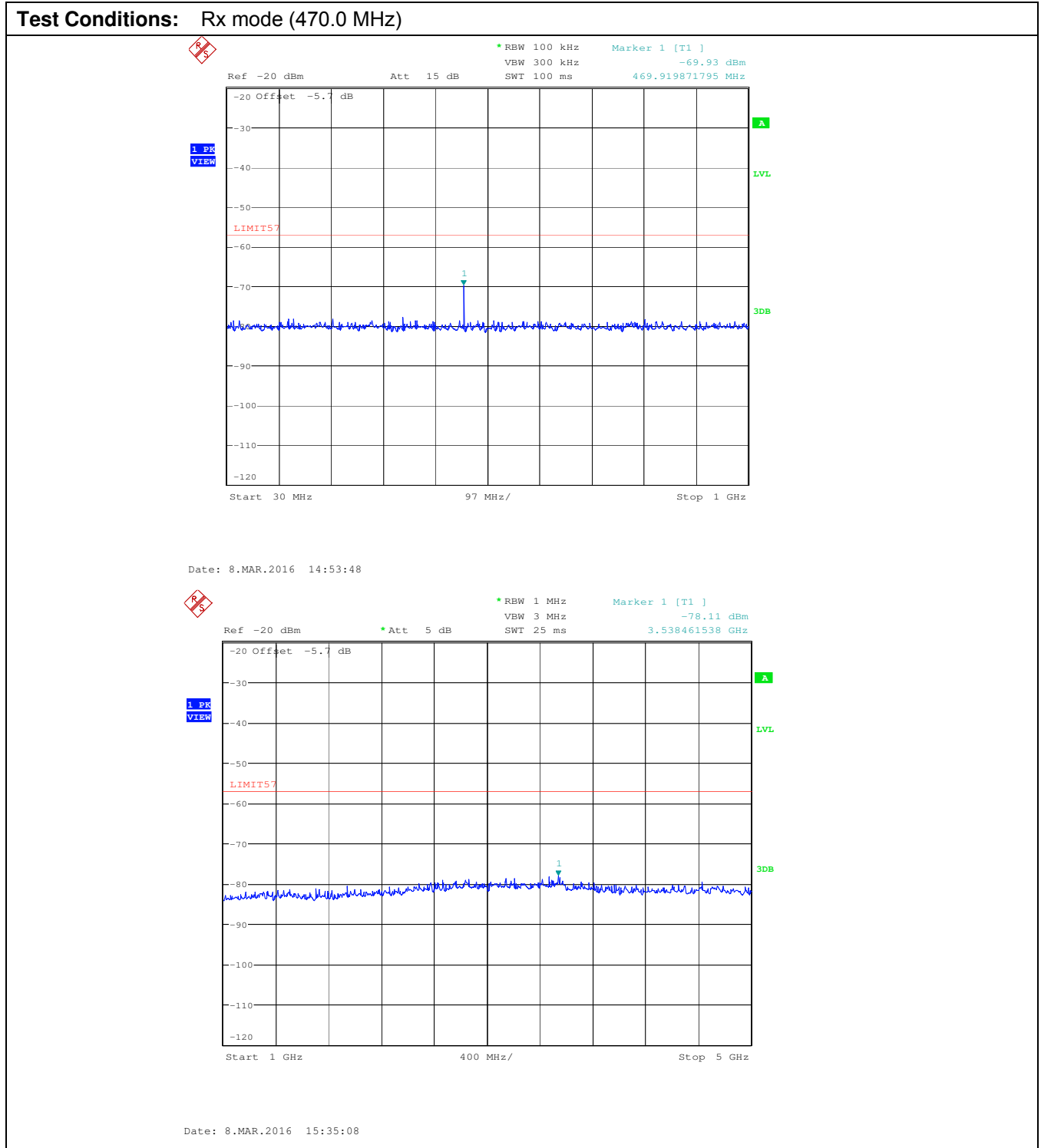

ULTRATECH GROUP OF LABS

3000 Bristol Circle, Oakville, Ontario, Canada L6H 6G4
Tel. #: 905-829-1570, Fax. #: 905-829-8050, Email: vic@ultratech-labs.com, Website: <http://www.ultratech-labs.com>

File #: 16ICOM416Q_FCC15B121

March 14, 2016

All test results contained in this engineering test report are traceable to National Institute of Standards and Technology (NIST)

5.4.4.2. ANT 2 in Rx Mode

Plot 7: Conducted Receiver Spurious Emissions, 30 MHz – 5 GHz

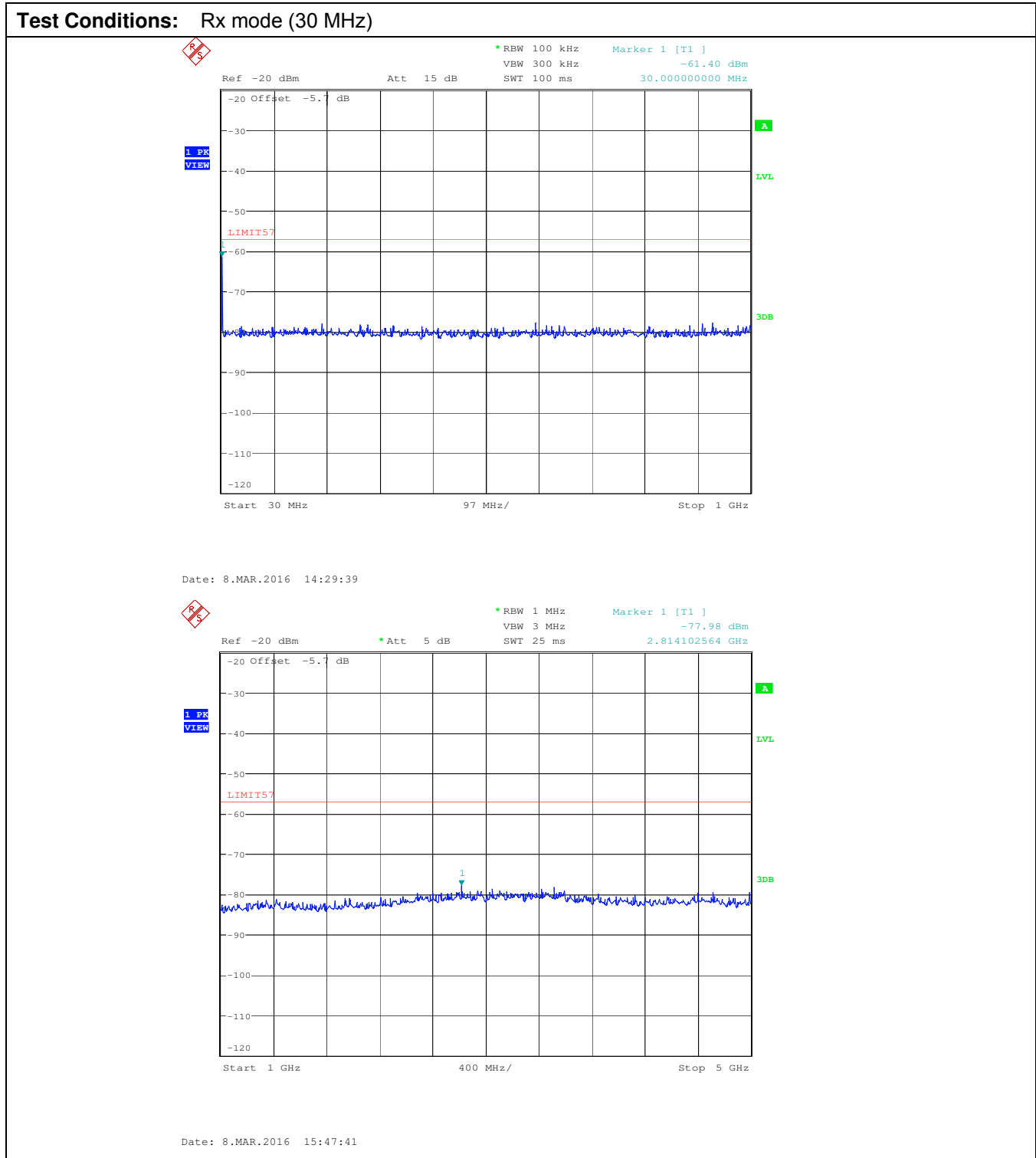

Plot 8: Conducted Receiver Spurious Emissions, 30 MHz – 5 GHz

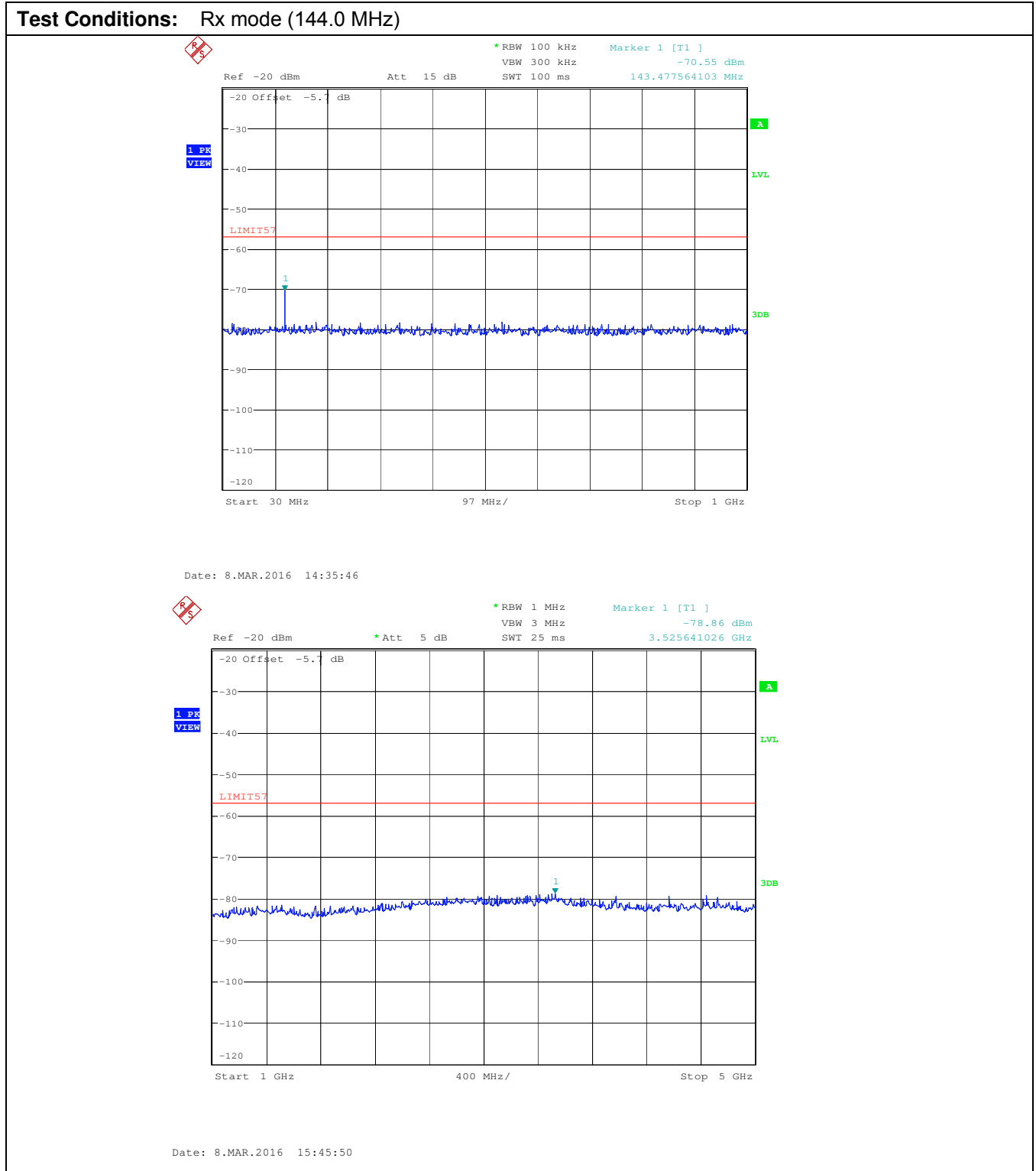

ULTRATECH GROUP OF LABS

3000 Bristol Circle, Oakville, Ontario, Canada L6H 6G4
Tel. #: 905-829-1570, Fax. #: 905-829-8050, Email: vic@ultratech-labs.com, Website: <http://www.ultratech-labs.com>

File #: 16ICOM416Q_FCC15B121

March 14, 2016

All test results contained in this engineering test report are traceable to National Institute of Standards and Technology (NIST)

Plot 9: Conducted Receiver Spurious Emissions, 30 MHz – 5 GHz

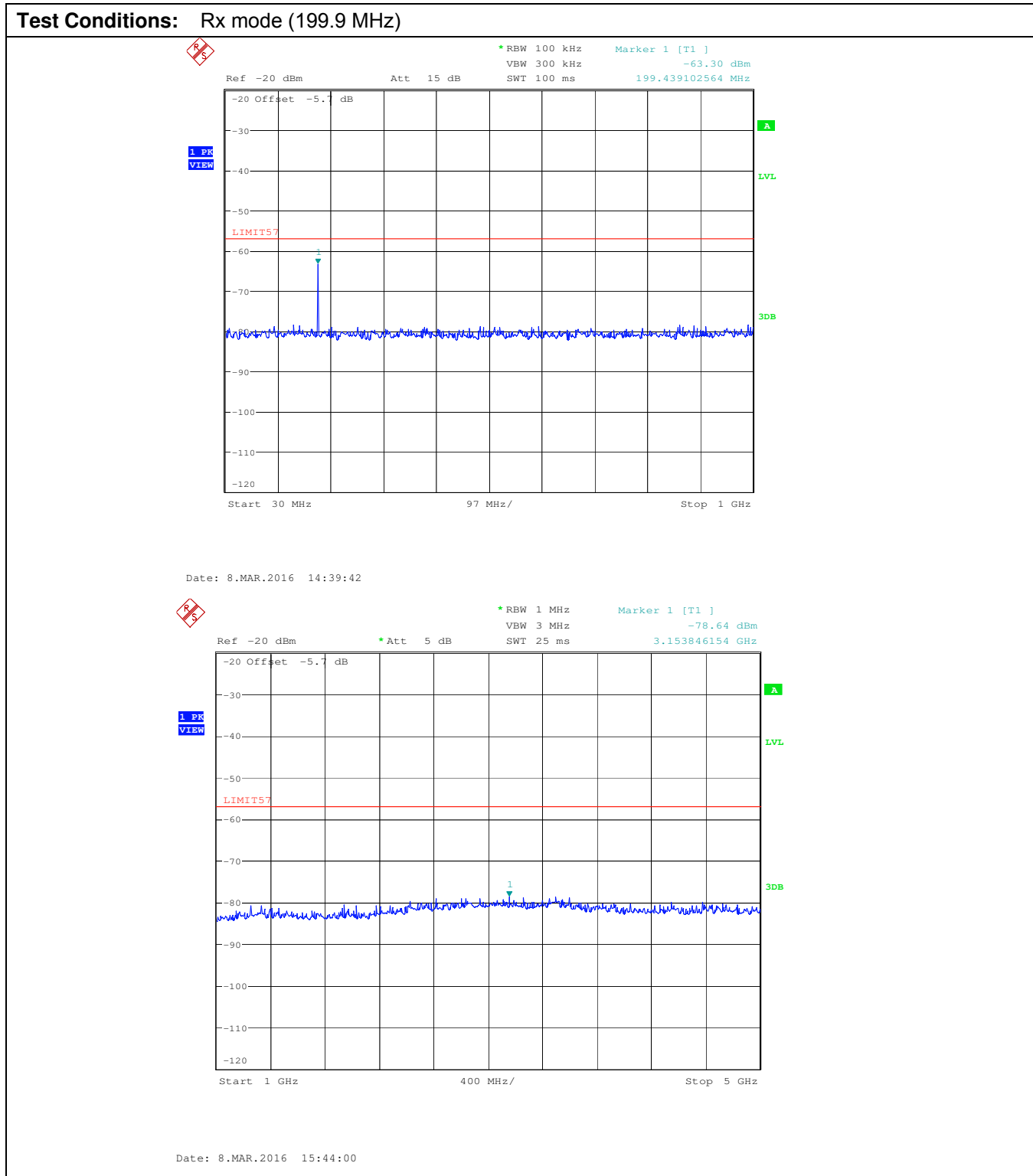

ULTRATECH GROUP OF LABS

3000 Bristol Circle, Oakville, Ontario, Canada L6H 6G4
Tel. #: 905-829-1570, Fax. #: 905-829-8050, Email: vic@ultratech-labs.com, Website: <http://www.ultratech-labs.com>

File #: 16ICOM416Q_FCC15B121

March 14, 2016

All test results contained in this engineering test report are traceable to National Institute of Standards and Technology (NIST)

Plot 10: Conducted Receiver Spurious Emissions, 30 MHz – 5.0 GHz

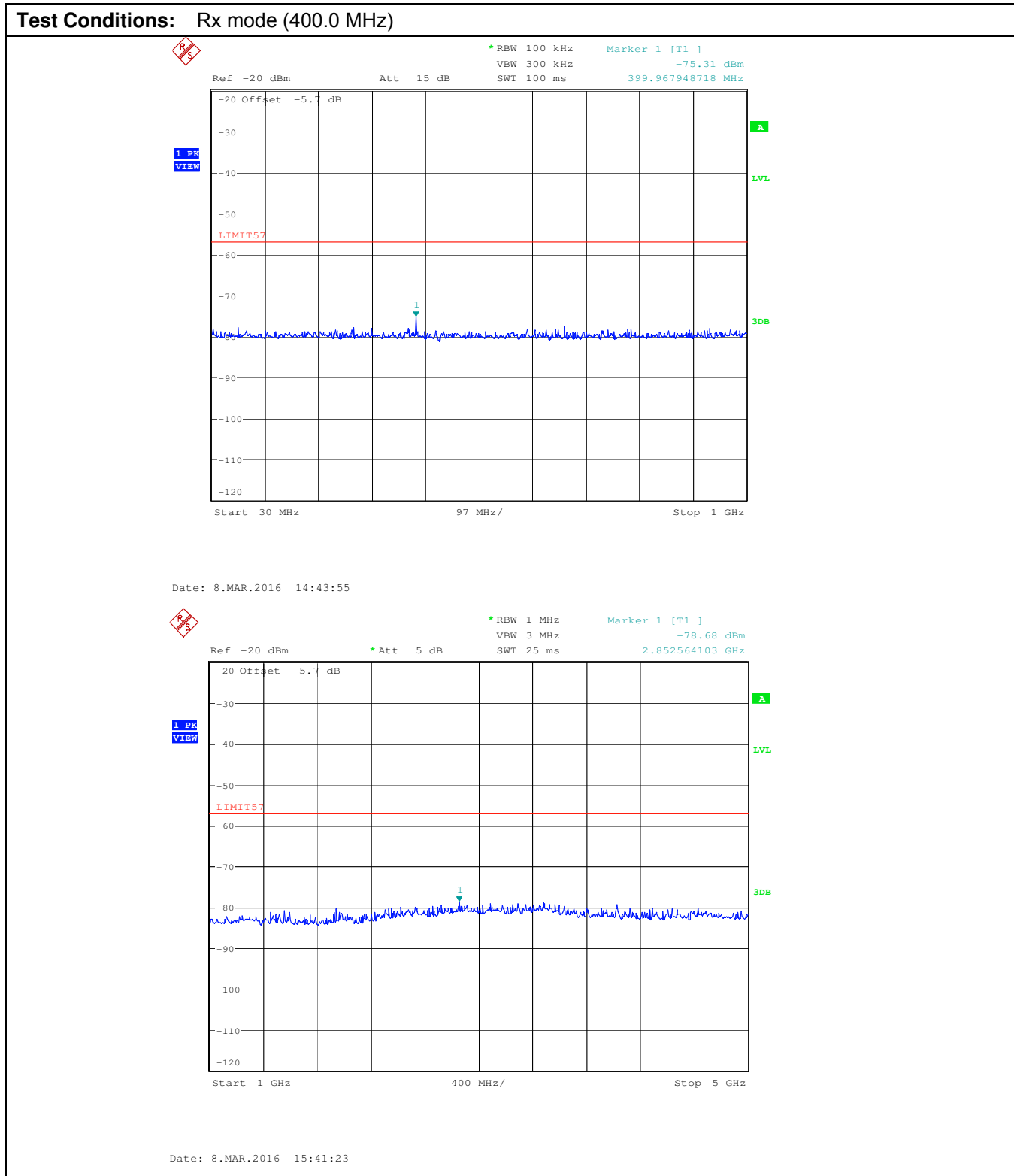

ULTRATECH GROUP OF LABS

3000 Bristol Circle, Oakville, Ontario, Canada L6H 6G4
Tel. #: 905-829-1570, Fax. #: 905-829-8050, Email: vic@ultratech-labs.com, Website: <http://www.ultratech-labs.com>

File #: 16ICOM416Q_FCC15B121

March 14, 2016

All test results contained in this engineering test report are traceable to National Institute of Standards and Technology (NIST)

Plot 11: Conducted Receiver Spurious Emissions, 30 MHz – 5.0 GHz

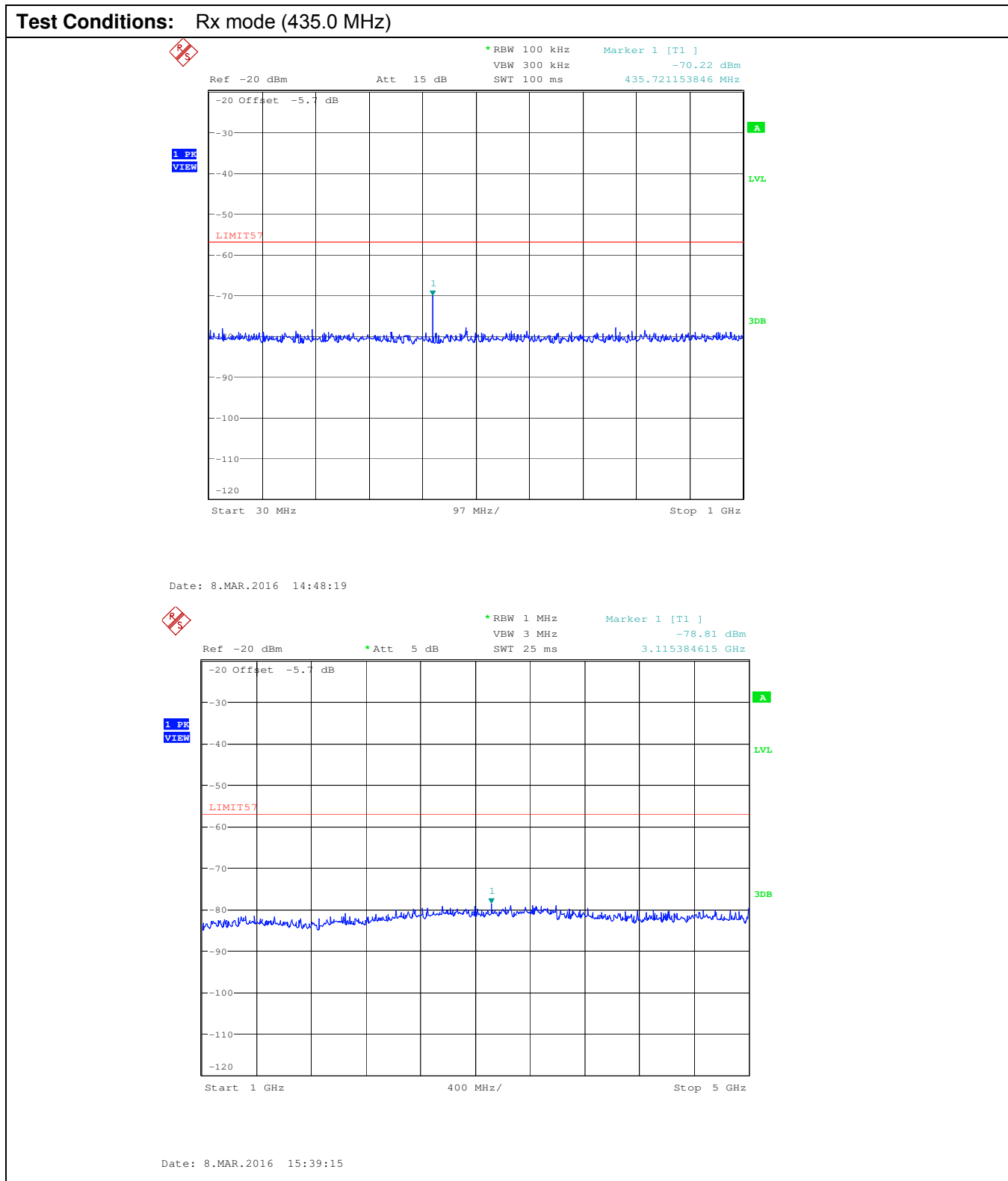

ULTRATECH GROUP OF LABS

3000 Bristol Circle, Oakville, Ontario, Canada L6H 6G4
Tel. #: 905-829-1570, Fax. #: 905-829-8050, Email: vic@ultratech-labs.com, Website: <http://www.ultratech-labs.com>

File #: 16ICOM416Q_FCC15B121

March 14, 2016

All test results contained in this engineering test report are traceable to National Institute of Standards and Technology (NIST)

Plot 12: Conducted Receiver Spurious Emissions, 30 MHz – 5.0 GHz

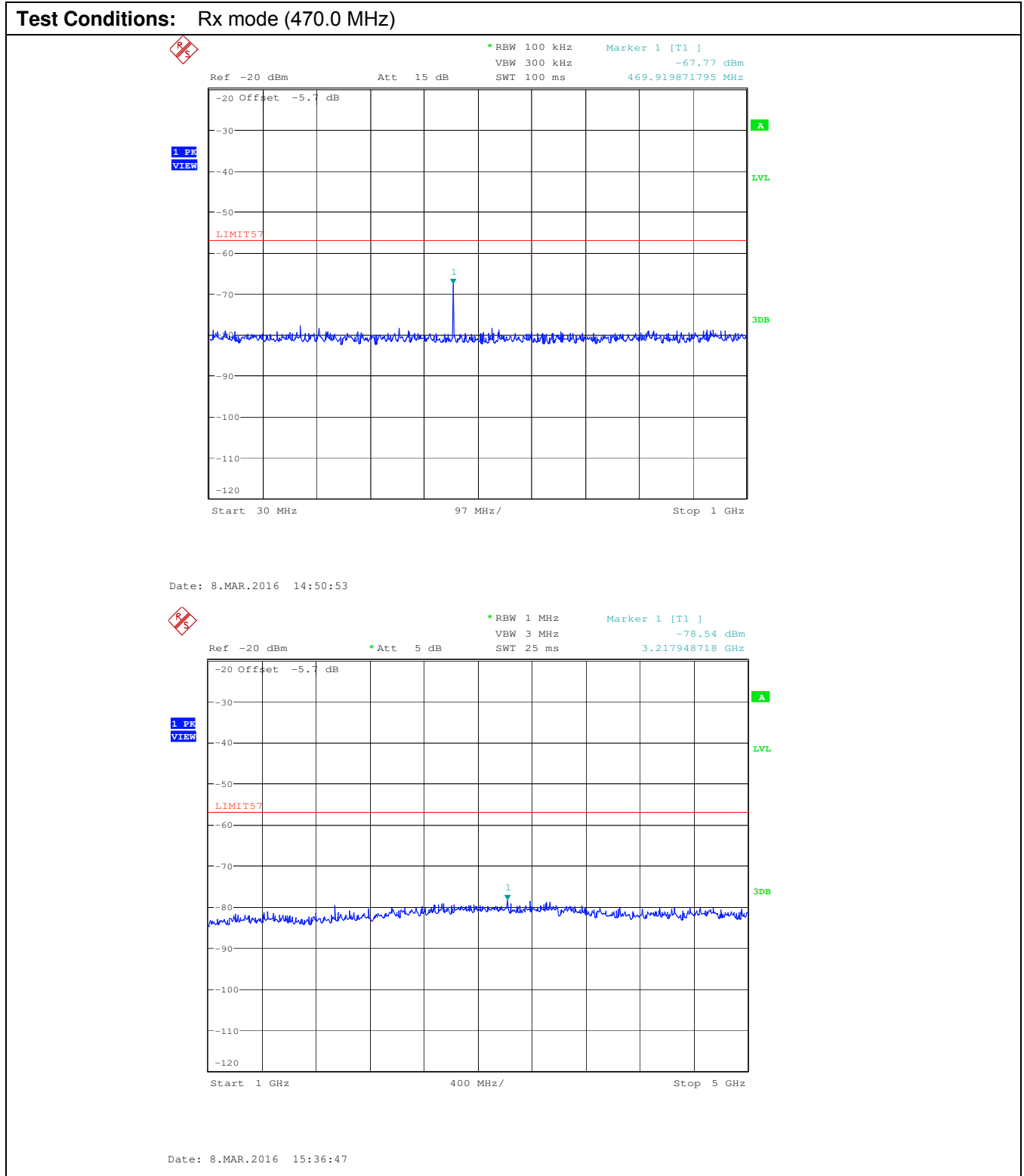

ULTRATECH GROUP OF LABS

3000 Bristol Circle, Oakville, Ontario, Canada L6H 6G4
Tel. #: 905-829-1570, Fax. #: 905-829-8050, Email: vic@ultratech-labs.com, Website: <http://www.ultratech-labs.com>

File #: 16ICOM416Q_FCC15B121

March 14, 2016

All test results contained in this engineering test report are traceable to National Institute of Standards and Technology (NIST)

5.5. SPURIOUS/HARMONIC RADIATED EMISSIONS FROM RECEIVER AND CLASS B UNINTENTIONAL RADIATORS (DIGITAL DEVICES) [§ 15.109(a)]

5.5.1. Limits

The equipment shall meet the limits of the following table:

Test Frequency Range (MHz)	Class B Limits @ 3 m (dB μ V/m)
30 – 88	40.0
88 – 216	43.5
216 – 960	46.0
Above 960	54.0

5.5.2. Method of Measurements

Refer to Ultratech Test Procedures ULTR-P001-200 & ANSI C63.4 for method of measurements.

The spectrum shall be investigated from the lowest radio frequency signal generated or used in the device, without going below the lowest frequency for which a radiated emission limit is specified, up to the frequency shown in the following table:

Highest frequency generated or used in the device or on which the device operates or tunes (MHz)	Upper frequency of measurement range (MHz)
Below 1.705	30
1.705 - 108	1000
108 – 500	2000
500 -1000	5000
Above 1000	5 th harmonic of the highest frequency or 40 GHz, whichever is lower

5.5.3. Test Arrangement

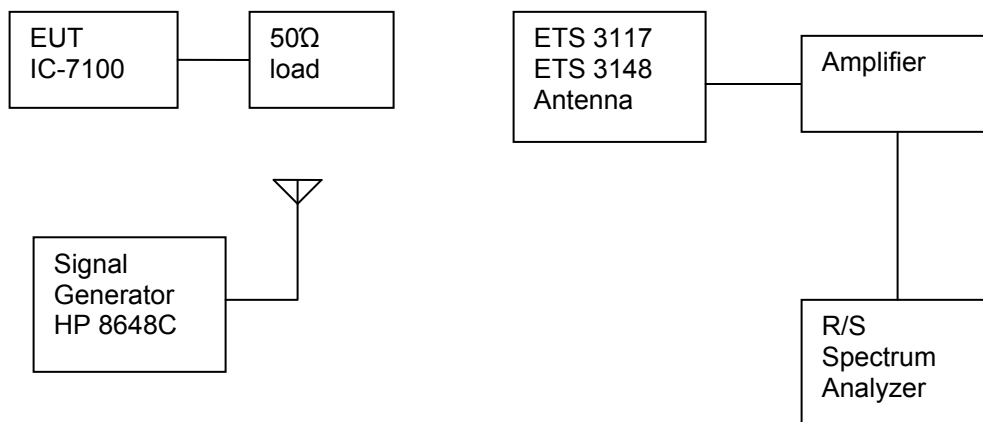

5.5.4. Test Data

Remarks:

- The measuring receiver shall be tuned over the frequency range 30 MHz to 6 GHz @ 3m.
- All spurious emissions that are in excess of 20 dB below the specified limit shall be recorded.

5.5.4.1. Lowest Frequency (30.0 MHz)

Frequency (MHz)	RF Level (dBμV/m)	Detector Used (Peak/QP/Avg)	Antenna Plane (H/V)	Limit (dBμV/m)	Margin (dB)	Pass/Fail
All receiver spurious emissions are more than 20 dB below the limit.						

5.5.4.2. Near Middle Frequency (144.0 MHz)

Frequency (MHz)	RF Level (dBμV/m)	Detector Used (Peak/QP/Avg)	Antenna Plane (H/V)	Limit (dBμV/m)	Margin (dB)	Pass/Fail
268.487	27.31	Peak	V	46.0	-18.7	Pass
268.487	28.01	Peak	H	46.0	-18.0	Pass
805.461	35.11	Peak	V	46.0	-10.9	Pass
805.461	39.90	Peak	H	46.0	-6.1	Pass
1342.425	43.90	Peak	V	54.0	-10.1	Pass
1342.425	44.75	Peak	H	54.0	-9.2	Pass
All receiver spurious emissions are more than 20 dB below the limit.						

5.5.4.3. Highest Frequency (199.90 MHz)

Frequency (MHz)	RF Level (dB μ V/m)	Detector Used (Peak/QP/Avg)	Antenna Plane (H/V)	Limit (dB μ V/m)	Margin (dB)	Pass/Fail
All receiver spurious emissions are more than 20 dB below the limit.						

5.5.4.4. Lowest Frequency (400.0 MHz)

Frequency (MHz)	RF Level (dB μ V/m)	Detector Used (Peak/QP/Avg)	Antenna Plane (H/V)	Limit (dB μ V/m)	Margin (dB)	Pass/Fail
524.487	36.90	Peak	V	46.0	-9.1	Pass
524.487	35.15	Peak	H	46.0	-10.8	Pass
1048.974	47.76	Peak	V	54.0	-6.2	Pass
1048.974	47.35	Peak	H	54.0	-6.6	Pass
1573.461	50.08	QP	V	54.0	-3.9	Pass
1573.461	49.60	QP	H	54.0	-4.4	Pass
All receiver spurious emissions are more than 20 dB below the limit.						

5.5.4.5. Near Middle Frequency (435.0 MHz)

Frequency (MHz)	RF Level (dB μ V/m)	Detector Used (Peak/QP/Avg)	Antenna Plane (H/V)	Limit (dB μ V/m)	Margin (dB)	Pass/Fail
559.487	40.40	QP	V	46.0	-5.6	Pass
559.487	43.65	QP	H	46.0	-2.3	Pass
1118.974	49.48	Peak	V	54.0	-4.5	Pass
1118.974	45.78	Peak	H	54.0	-8.2	Pass
1678.461	49.87	QP	V	54.0	-4.1	Pass
1678.461	51.20	QP	H	54.0	-2.8	Pass
All receiver spurious emissions are more than 20 dB below the limit.						

5.5.4.6. Highest Frequency (470.0 MHz)

Frequency (MHz)	RF Level (dB μ V/m)	Detector Used (Peak/QP/Avg)	Antenna Plane (H/V)	Limit (dB μ V/m)	Margin (dB)	Pass/Fail
594.487	31.67	Peak	V	46.0	-14.3	Pass
594.487	34.66	Peak	H	46.0	-11.3	Pass
1188.974	45.85	Peak	V	54.0	-8.1	Pass
1188.974	42.41	Peak	H	54.0	-11.6	Pass
1783.461	52.71	QP	V	54.0	-1.3	Pass
1783.461	48.99	QP	H	54.0	-5.0	Pass
All receiver spurious emissions are more than 20 dB below the limit.						

5.5.4.7. Radiated Emissions from Class B Digital Devices

Remark: The emissions were scanned from 30 MHz to 6 GHz at 3 m distance.
 Rx was set at 30 MHz & also in scanning mode.

Frequency (MHz)	Measured Field Strength @ 3 m (dBµV/m)	Detector Used (Peak/QP)	Antenna Plane (H/V)	Field Strength Limits (dBµV/m)	Margin (dB)
42.43	33.2	QP	V	40.0	-6.8
42.43	27.2	Peak	H	40.0	-12.8
89.07	29.9	Peak	V	43.5	-13.6
117.05	36.2	Peak	V	43.5	-7.3
117.05	27.4	Peak	H	43.5	-16.1
762.16	37.5	Peak	V	46.0	-8.5
762.16	38.0	Peak	H	46.0	-8.0
836.77	36.8	Peak	V	46.0	-9.2
836.77	37.9	Peak	H	46.0	-8.1
909.83	38.0	Peak	V	46.0	-8.0
909.83	35.7	Peak	H	46.0	-10.3
959.58	37.5	Peak	V	46.0	-8.5
959.58	35.1	Peak	H	46.0	-10.9
1112.0	43.5	Peak	V	54.0	-10.5
1112.0	40.8	Peak	H	54.0	-13.2
1482.0	44.8	Peak	V	54.0	-9.2
1482.0	45.9	Peak	H	54.0	-8.1

All other emissions are more than 20 dB below the limit.

EXHIBIT 6. TEST EQUIPMENTS LIST

Test Instruments	Manufacturer	Model No.	Serial No.	Frequency Range	Cal. Due Date
Spectrum Analyzer	Rohde & Schwarz	FSU	100398	20Hz - 26.5GHz	14 Sep 2017
EMI Receiver	Rohde & Schwarz	ESU40	100037	20Hz - 40GHz	08 May 2017
Pre Amplifier	Com-Power	PAM-103A	161243	10MHz - 1GHz	10 Jun 2016
Pre Amplifier	Com-Power	PAM-118A	551052	500MHz - 18GHz	13 Jul 2016
Bi-conical Antenna	ETS EMCO	3110B	3379	20-200MHz	11 Sep 2016
Biconilog Antenna	ETS EMCO	3142C	026873	26-3000MHz	14 Apr 2016
Horn Antenna	EMCO	3115	9911-9555	1GHz - 18GHz	26 Mar 2016
Combiner	Mini Circuit	ZFSC-3-4	9629 02	1MHz - 1GHz	--
Radiocommunication Service Monitor	Rohde & Schwarz	CMS 54	DE22858	0.3-2200MHz	27 Mar 2016
RF Signal Generator	Marconi Instruments	2024	112255/164	9KHz-2.4GHz	27 Aug 2017
Signal Generator	Hewlett Packard	8648	3443U00391	100KHz-3.2GHz	02 Feb 2017
Distortion analyzer	Hewlett-Packard	8903E	3514A01460	20Hz - 100KHz	10 Mar 2016

ULTRATECH GROUP OF LABS

3000 Bristol Circle, Oakville, Ontario, Canada L6H 6G4
 Tel. #: 905-829-1570, Fax. #: 905-829-8050, Email: vic@ultratech-labs.com, Website: <http://www.ultratech-labs.com>

File #: 16ICOM416Q_FCC15B121

March 14, 2016

All test results contained in this engineering test report are traceable to National Institute of Standards and Technology (NIST)

EXHIBIT 7. MEASUREMENT UNCERTAINTY

The measurement uncertainties stated were calculated in accordance with the requirements of CISPR 16-4-2 @ IEC:2003 and JCGM 100:2008 (GUM 1995) – Guide to the Expression of Uncertainty in Measurement.

7.1. LINE CONDUCTED EMISSION MEASUREMENT UNCERTAINTY

	Line Conducted Emission Measurement Uncertainty (150 kHz – 30 MHz):	Measured	Limit
u_c	Combined standard uncertainty: $u_c(y) = \sqrt{\sum_{i=1}^m u_i^2(y)}$	± 1.57	± 1.8
U	Expanded uncertainty U: $U = 2u_c(y)$	± 3.14	± 3.6

7.2. RADIATED EMISSION MEASUREMENT UNCERTAINTY

	Radiated Emission Measurement Uncertainty @ 3m, Horizontal (30-1000 MHz):	Measured	Limit
u_c	Combined standard uncertainty: $u_c(y) = \sqrt{\sum_{i=1}^m u_i^2(y)}$	± 2.15	± 2.6
U	Expanded uncertainty U: $U = 2u_c(y)$	± 4.30	± 5.2

	Radiated Emission Measurement Uncertainty @ 3m, Vertical (30-1000 MHz):	Measured	Limit
u_c	Combined standard uncertainty: $u_c(y) = \sqrt{\sum_{i=1}^m u_i^2(y)}$	± 2.39	± 2.6
U	Expanded uncertainty U: $U = 2u_c(y)$	± 4.78	± 5.2

	Radiated Emission Measurement Uncertainty @ 3 m, Horizontal & Vertical (1 – 18 GHz):	Measured	Limit
u_c	Combined standard uncertainty: $u_c(y) = \sqrt{\sum_{i=1}^m u_i^2(y)}$	± 1.87	Under consideration
U	Expanded uncertainty U: $U = 2u_c(y)$	± 3.75	Under consideration