

ENGINEERING TEST REPORT

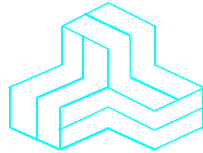

Scanning Receiver Model No.: IC-R6

FCC ID: AFJ325000

Applicant:

ICOM Incorporated
1-1-32, Kamiminami, Hirano-ku
Osaka, Japan, 547-0003

Tested in Accordance With

Federal Communications Commission (FCC)
47 CFR, Part 15, Subpart B
Scanning Receivers Operating in the Frequency Band
30 MHz - 960 MHz (excluding cellular bands)

UltraTech's File No.: 15ICOM408_FCC15C121

This Test report is Issued under the Authority of
Tri M. Luu, BAsC,
Vice President of Engineering
UltraTech Group of Labs

Date: October 26, 2015

Report Prepared by: Dharmajit Solanki

Tested by: Wayne Wu, EMI/RFI Technician

Issued Date: October 26, 2015

Test Dates: October 20-23, 2015

- *The results in this Test Report apply only to the sample(s) tested, and the sample tested is randomly selected.*
- *This report must not be used by the client to claim product endorsement by NVLAP or any agency of the US Government.*

UltraTech

3000 Bristol Circle, Oakville, Ontario, Canada, L6H 6G4
Tel.: (905) 829-1570 Fax.: (905) 829-8050
Website: www.ultratech-labs.com, Email: vic@ultratech-labs.com, Email: tri@ultratech-labs.com



91038



1309



46390-2049



NVLAP LAB
CODE 200093-0



AT-1945



SL2-IN-E-
1119R



CA2049



TL363_B



TPTDP
DA1300

TABLE OF CONTENTS

EXHIBIT 1.	INTRODUCTION	1
1.1.	SCOPE.....	1
1.2.	RELATED SUBMITTAL(S)/GRANT(S)	1
1.3.	NORMATIVE REFERENCES	1
EXHIBIT 2.	PERFORMANCE ASSESSMENT	2
2.1.	CLIENT INFORMATION	2
2.2.	EQUIPMENT UNDER TEST (EUT) INFORMATION	2
2.3.	EUT'S TECHNICAL SPECIFICATIONS	3
2.4.	LIST OF EUT'S PORTS.....	3
2.5.	ANCILLARY EQUIPMENT	3
EXHIBIT 3.	EUT OPERATING CONDITIONS AND CONFIGURATIONS DURING TESTS	2
3.1.	OPERATIONAL TEST CONDITIONS & ARRANGEMENT FOR TEST SIGNALS.....	2
EXHIBIT 4.	SUMMARY OF TEST RESULTS	3
4.1.	LOCATION OF TESTS.....	3
4.2.	APPLICABILITY & SUMMARY OF EMC EMISSION TEST RESULTS	3
4.3.	MODIFICATIONS REQUIRED FOR COMPLIANCE.....	3
EXHIBIT 5.	MEASUREMENTS, EXAMINATIONS & TEST DATA FOR EMC EMISSIONS	4
5.1.	TEST PROCEDURES.....	4
5.2.	MEASUREMENT UNCERTAINTIES	4
5.3.	MEASUREMENT EQUIPMENT USED	4
5.4.	POWER LINE CONDUCTED EMISSIONS [§ 15.107(A)].....	5
5.5.	RECEIVER ANTENNA POWER SPURIOUS/HARMONIC CONDUCTED EMISSIONS [§15.111(A)]	8
5.6.	SPURIOUS/HARMONIC RADIATED EMISSIONS FROM RECEIVER AND CLASS B UNINTENTIONAL RADIATORS (DIGITAL DEVICES) [§ 15.109(A)]	13
5.7.	REQUIREMENTS FOR SCANNING RECEIVERS [§ 15.121].....	16
5.8.	SCANNING RECEIVERS CELLULAR BAND REJECTION [§ 15.121(B)]	19
EXHIBIT 6.	TEST EQUIPMENTS LIST	21
EXHIBIT 7.	MEASUREMENT UNCERTAINTY	22
7.1.	LINE CONDUCTED EMISSION MEASUREMENT UNCERTAINTY	22
7.2.	RADIATED EMISSION MEASUREMENT UNCERTAINTY	22

EXHIBIT 1. INTRODUCTION

1.1. SCOPE

Reference:	FCC Part 15, Subpart B, Sections 15.107, 15.109, 15.111 & 15.121
Title:	Code of Federal Regulations (CFR), Title 47, Telecommunication, Part 15
Purpose of Test:	To gain FCC Class II Permissive Change acceptance for Scanning Receivers Operating in 30 MHz - 960 MHz band (excluding cellular bands).
Test Procedures:	Both conducted and radiated emissions measurements were conducted in accordance with American National Standards Institute ANSI C63.4 - American National Standard for Methods of Measurement of Radio-Noise Emissions from Low-Voltage Electrical and Electronic Equipment in the Range of 9 kHz to 40 GHz.
Environmental Classification:	Residential, Commercial, Industrial or Business environment.

1.2. RELATED SUBMITTAL(S)/GRANT(S)

None

1.3. NORMATIVE REFERENCES

Publication	Year	Title
FCC CFR Title 47, Parts 0-19	2015	Code of Federal Regulations – Telecommunication
ANSI C63.4	2014	American National Standard for Methods of Measurement of Radio-Noise Emissions from Low-Voltage Electrical and Electronic Equipment in the Range of 9 kHz to 40 GHz
ANSI C63.10	2009	American National Standard for Testing Unlicensed Wireless Devices
CISPR 22 EN 55022	2008-09, Ed 6 2009	Information Technology Equipment - Radio Disturbance Characteristics - Limits and Methods of Measurement

EXHIBIT 2. PERFORMANCE ASSESSMENT

2.1. CLIENT INFORMATION

APPLICANT	
Name:	Icom Incorporated
Address:	1-1-32, Kamiminami, Hirano-ku, Osaka Japan, 547-0003
Contact Person:	Mr. Hideji Fujishima Phone #: +81-66-793-8424 Fax #: +81-66-793-3336 Email Address: world_support@icom.co.jp

MANUFACTURER	
Name:	Icom Incorporated
Address:	1-1-32, Kamiminami Hirano-ku, Osaka Japan, 547-0003
Contact Person:	Mr. Hideji Fujishima Phone #: +81-66-793-8424 Fax #: +81-66-793-3336 Email Address: world_support@icom.co.jp

2.2. EQUIPMENT UNDER TEST (EUT) INFORMATION

The following information (with the exception of the Date of Receipt) has been supplied by the applicant.

Brand Name:	ICOM Incorporated
Product:	Scanning Receiver
Model Name or Number:	IC-R6
Serial Number:	00000406
Type of Equipment:	Scanning Receiver
Accessories:	Icom AC Adaptor, Model BC-196SA, INPUT: 120VAC 60Hz, 6W, OUTPUT: 4.5V DC, 400 mA
Power input source:	2 AA (R6) Ni MH cells or 4.5V dc at Dc Jack

2.3. EUT'S TECHNICAL SPECIFICATIONS

RECEIVER	
Equipment Type:	Portable
Power Supply Requirement:	4.5V dc at Dc Jack, or 2 AA (R6) Ni MH or alkaline cells
Operating Frequency Range:	0.100–823.995 MHz, 851.000–866.995 MHz & 896.000–1309.995 MHz
Intermediate Frequencies:	FM/AM: 1 st 266.7MHz, 2 nd 19.65 MHz, 3 rd 450 kHz WFM: 1 st 266.7MHz, 2 nd 19.95 MHz, 3 rd 750 kHz
RF Input Impedance:	50 Ω

2.4. LIST OF EUT'S PORTS

Port Number	EUT's Port Description	Number of Identical Ports	Connector Type	Cable Type (Shielded/Non-shielded)
1	Antenna Connector	1	SMA	N/A
2	External DC In Jack	1	Power Jack	Non-Shielded
3	External Speaker Jack	1	I/O Jack	Non-Shielded

2.5. ANCILLARY EQUIPMENT

The EUT was tested while connected to the following representative configuration of ancillary equipment necessary to exercise the ports during tests:

Ancillary Equipment # 1	
Description:	AC Adaptor
Brand name:	ICOM
Model Name or Number:	BC-196SA AC adaptor
Cable Type:	Non-Shielded

Ancillary Equipment # 2	
Description:	Speaker load 8 ohm resistor
Cable Type:	Non-Shielded

EXHIBIT 3. EUT OPERATING CONDITIONS AND CONFIGURATIONS DURING TESTS

3.1. OPERATIONAL TEST CONDITIONS & ARRANGEMENT FOR TEST SIGNALS

Operating Modes:	The receiver was operated in the normal intended mode during testing
Special Test Software:	None
Special Hardware Used:	None
Receiver Test Antenna:	The EUT's was tested with its antenna connected as intended.

Receiver Test Signals	
Frequency Band(s):	0.100–823.995 MHz, 851.000–866.995 MHz & 896.000–1309.995MHz
Test Frequency(ies): (Near lowest, near middle & near highest frequencies in the frequency range of operation.)	30 MHz, 650 MHz, 960 MHz

EXHIBIT 4. SUMMARY OF TEST RESULTS

4.1. LOCATION OF TESTS

All of the measurements described in this report were performed at Ultratech Group of Labs located in the city of Oakville, Province of Ontario, Canada.

- Power Line Conducted Emissions were performed in UltraTech's shielded room, 16'(L) by 12'(W) by 12'(H).
- Radiated Emissions were performed at the Ultratech's 3-10 TDK Semi-Anechoic Chamber situated in the Town of Oakville, province of Ontario. This test site has been calibrated in accordance with ANSI C63.4, and found to be in compliance with the requirements of Sec. 2.948 of the FCC Rules. The descriptions and site measurement data of the Oakville 3-10 TDK Semi-Anechoic Chamber has been filed with FCC office (FCC File No.: 91038) and Industry Canada office (Industry Canada File No.: 2049A-3). Expiry Date: 2017-04-02.

4.2. APPLICABILITY & SUMMARY OF EMC EMISSION TEST RESULTS

FCC Part 15, Subpart B	Test Requirements	Compliance (Yes/No)
15.107(a), Class B	Power Line Conducted Emissions Measurements	Yes
15.111(a)	Receiver Antenna Power Conducted Emissions for Non-Integral Antenna Port	Yes
15.109(a)	Radiated Emissions from Scanning Receivers & Class B Digital Device	Yes
15.121	Requirements for Scanning Receivers	Yes

4.3. MODIFICATIONS REQUIRED FOR COMPLIANCE

None

EXHIBIT 5. MEASUREMENTS, EXAMINATIONS & TEST DATA FOR EMC EMISSIONS

5.1. TEST PROCEDURES

Please refer to Ultratech Test Procedures, File# ULTR-P001-2004 and for Test Procedures.

5.2. MEASUREMENT UNCERTAINTIES

The measurement uncertainties stated were calculated in accordance with the requirements of CISPR 16-4-2 @ IEC:2003 and JCGM 100:2008 (GUM 1995) – Guide to the Expression of Uncertainty in Measurement. Please refer to Exhibit 7 for Measurement Uncertainties.

5.3. MEASUREMENT EQUIPMENT USED

The measurement equipment used complied with the requirements of the Standards referenced in the Methods & Procedures ANSI C63.4 & 63.10 and CIPSR 16-1-1.

5.4. POWER LINE CONDUCTED EMISSIONS [§ 15.107(a)]

5.4.1. Limits

The equipment shall meet the limits of the following table:

Frequency of Emissions (MHz)	Class B Conducted Limit (dB μ V)	
	Quasi-Peak	Average
0.15 to 0.5	66 to 56*	56 to 46*
0.5 to 5	56	46
5 to 30	60	50

* Decreasing linearly with logarithm of frequency

5.4.2. Method of Measurements

Refer to Ultratech Test Procedures ULTR-P001-200 & ANSI C63.4 for method of measurements.

5.4.3. Test Arrangement

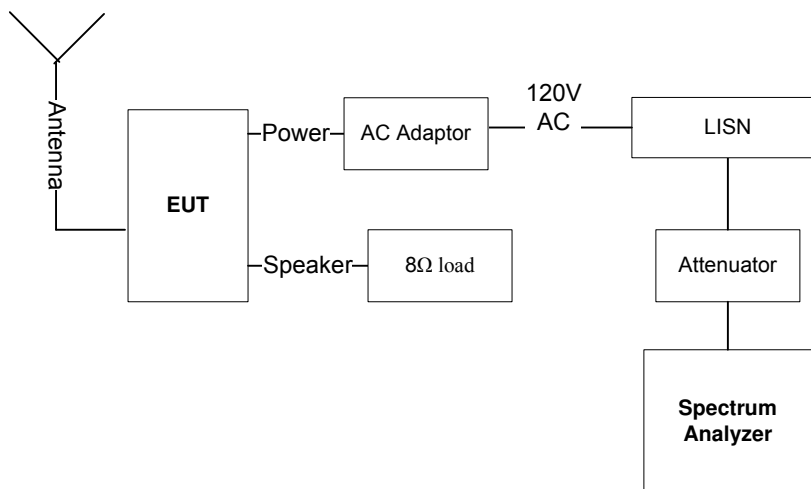

5.4.4. Test Data

Description: 120V AC, Scanning Mode.
 Setup Name: FCC 15 Class B
 Customer Name: ICOM America.
 Project Number: ICOM-408Q
 Operator Name: Wei
 EUT Name: IC-R6
 Date Created: 10/12/2015 11:35:02 PM

Current Graph

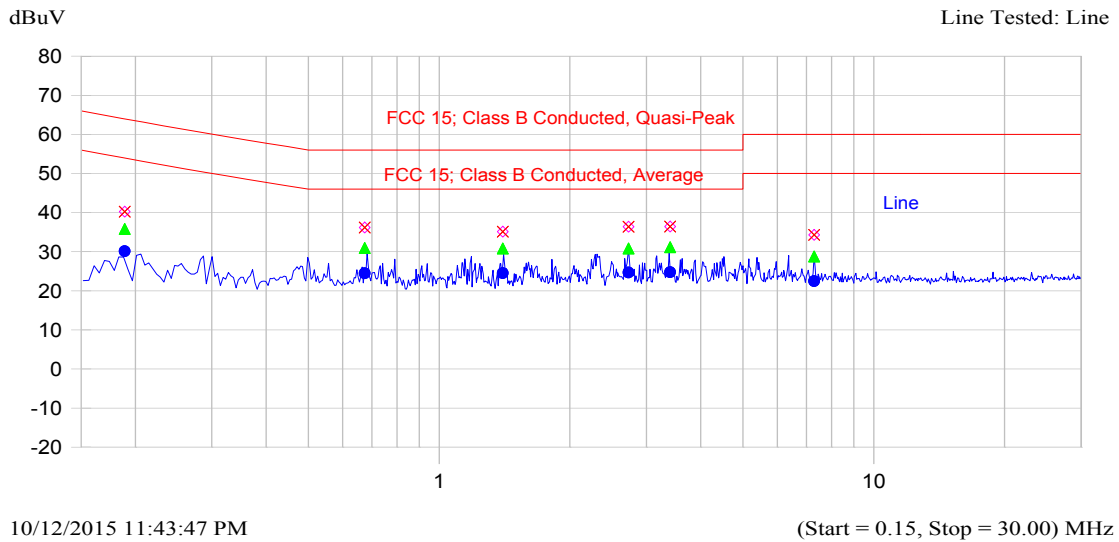

Current List

Frequency MHz	Peak dBuV	QP dBuV	Delta QP-QP Limit dB	Avg dBuV	Delta Avg-Avg Limit dB	Trace Name
0.189	40.2	35.8	-28.3	30.1	-24.0	Line
0.674	36.2	30.9	-25.1	24.5	-21.5	Line
1.401	35.1	30.8	-25.2	24.5	-21.5	Line
2.728	36.4	30.8	-25.2	24.7	-21.3	Line
3.399	36.4	31.1	-24.9	24.8	-21.2	Line
7.288	34.3	28.8	-31.2	22.5	-27.5	Line

Description: 120V AC, Scanning Mode.
 Setup Name: FCC 15 Class B
 Customer Name: ICOM America.
 Project Number: ICOM-408Q
 Operator Name: Wei
 EUT Name: IC-R6
 Date Created: 10/12/2015 11:35:02 PM

Current Graph

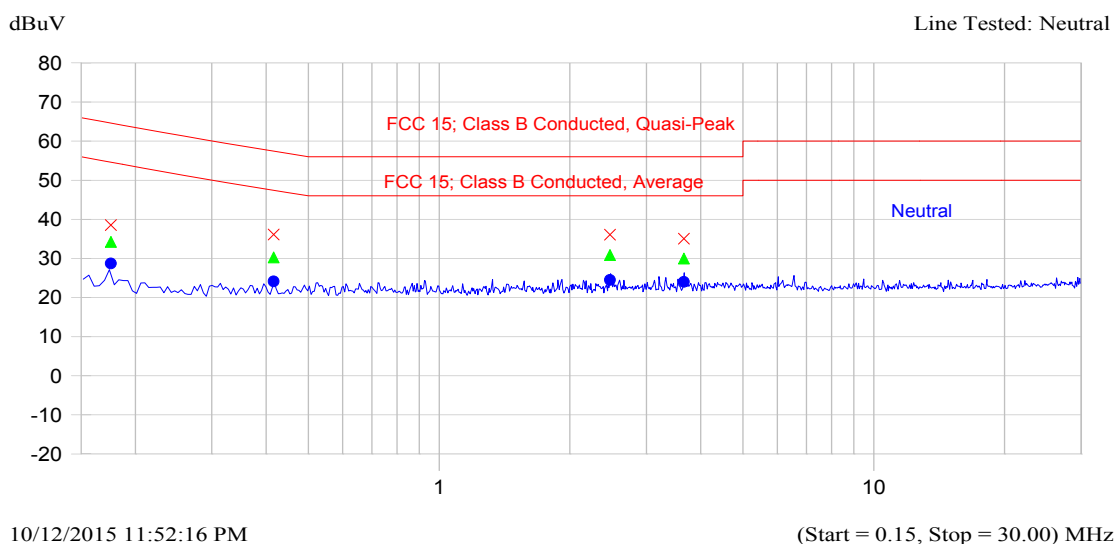

Current List

Frequency MHz	Peak dBuV	QP dBuV	Delta QP-QP Limit dB	Avg dBuV	Delta Avg-Avg Limit dB	Trace Name
0.176	38.5	34.2	-30.5	28.7	-26.0	Neutral
0.416	36.1	30.3	-27.3	24.1	-23.4	Neutral
2.471	36.1	30.9	-25.1	24.5	-21.5	Neutral
3.659	35.0	30.0	-26.0	24.0	-22.0	Neutral

5.5. RECEIVER ANTENNA POWER SPURIOUS/HARMONIC CONDUCTED EMISSIONS [§15.111(a)]

5.5.1. Limits

Receivers that operate (tune) in the frequency range 30 to 960 Mhz and CB receivers that provides terminals for the connection of an external antenna may be tested to demonstrate compliance with the provisions of @ 15.109 with the antenna terminals shielded and terminated with a resistive termination equal to the impedance specified for the antenna, provided these receivers also comply with the following:- ***With the receiver antenna terminal connected to a resistive termination equal to the impedance specified or employed for the antenna, the power at the antenna terminal at frequency within the range from 30 Mhz to 5th harmonic of the highest frequency shall not exceed 2.0 nanowatts (or -57 dBm @ 50 Ohm).***

5.5.2. Method of Measurements

Refer to Ultratech Test Procedures ULTR-P001-200 & ANSI C63.4 for method of measurements.

The spectrum shall be investigated from the lowest radio frequency signal generated or used in the device, without going below the lowest frequency for which a radiated emission limit is specified, up to the frequency shown in the following table:

Highest frequency generated or used in the device or on which the device operates or tunes (MHz)	Upper frequency of measurement range (MHz)
Below 1.705	30
1.705 - 108	1000
108 – 500	2000
500 -1000	5000
Above 1000	5 th harmonic of the highest frequency or 40 GHz, whichever is lower

5.5.3. Test Arrangement

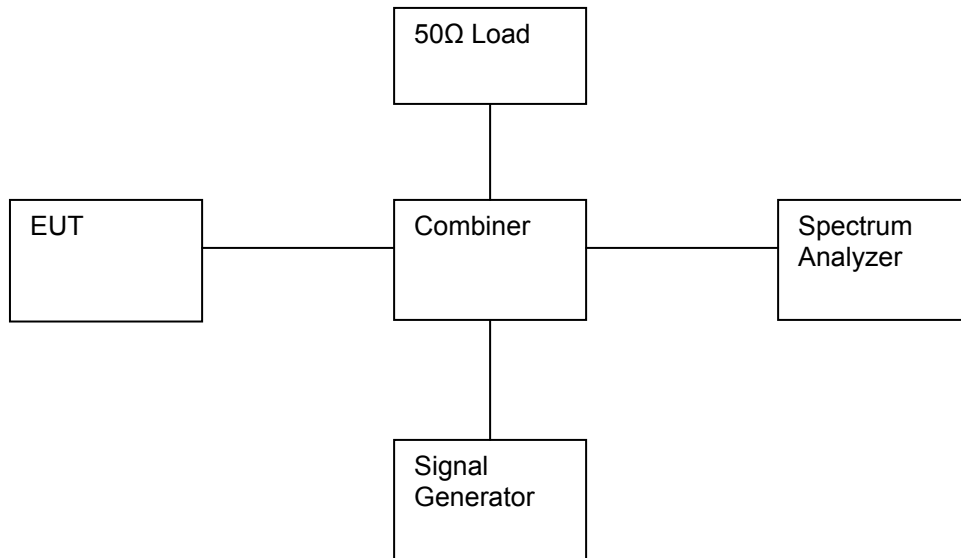

5.5.4. Test Data

5.5.4.1. Near Lowest Frequency (30 MHz, 60dBuV CW input)

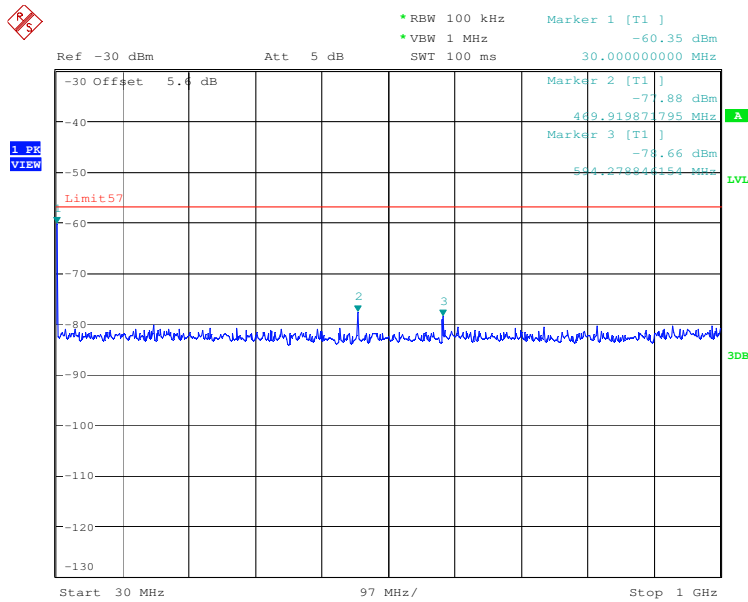

Date: 20.OCT.2015 14:04:57

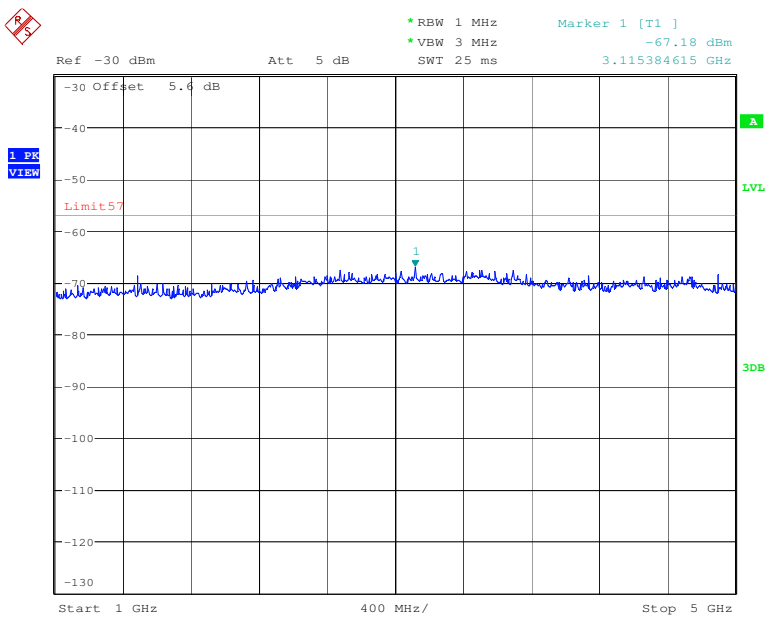

Date: 20.OCT.2015 14:16:35

5.5.4.2. Near Middle Frequency (650 MHz, 60dBuV CW input)

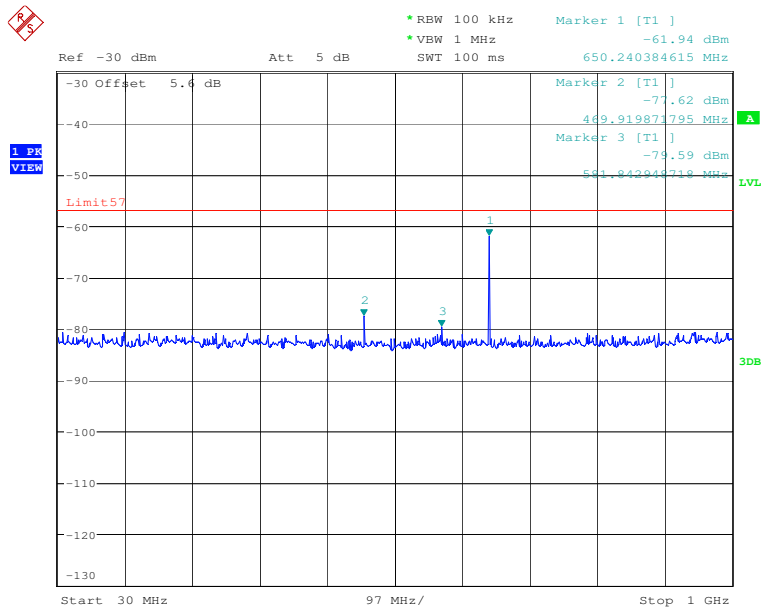

Date: 20.OCT.2015 14:07:11

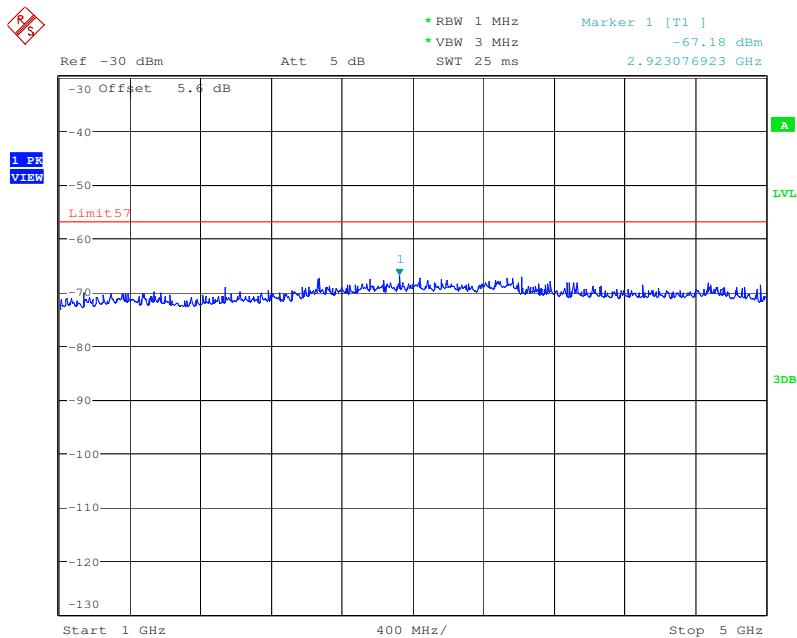

Date: 20.OCT.2015 14:14:08

ULTRATECH GROUP OF LABS

3000 Bristol Circle, Oakville, Ontario, Canada L6H 6G4
 Tel.: 905-829-1570, Fax. : 905-829-8050

File #: 15ICOM408_FCC15C121
 October 26, 2015

All test results contained in this engineering test report are traceable to National Institute of Standards and Technology (NIST)

5.5.4.3. Near Highest Frequency (960 MHz, 60dBuV CW input)

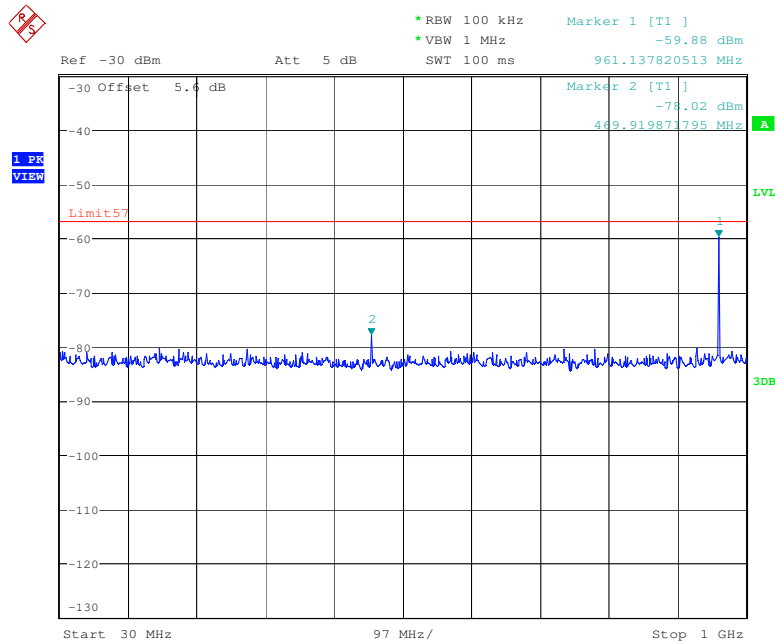

Date: 20.OCT.2015 14:10:45

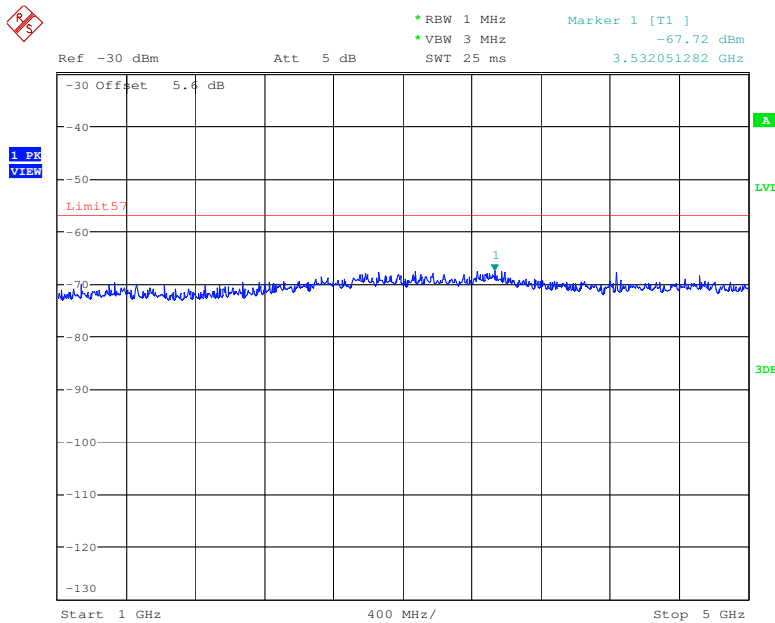

Date: 20.OCT.2015 14:12:16

ULTRATECH GROUP OF LABS

3000 Bristol Circle, Oakville, Ontario, Canada L6H 6G4
Tel.: 905-829-1570, Fax: 905-829-8050

File #: 15ICOM408_FCC15C121
October 26, 2015

All test results contained in this engineering test report are traceable to National Institute of Standards and Technology (NIST)

5.6. SPURIOUS/HARMONIC RADIATED EMISSIONS FROM RECEIVER AND CLASS B UNINTENTIONAL RADIATORS (DIGITAL DEVICES) [§ 15.109(a)]

5.6.1. Limits

The equipment shall meet the limits of the following table:

Test Frequency Range (MHz)	Class B Limits @ 3 m (dB μ V/m)
30 – 88	40.0
88 – 216	43.5
216 – 960	46.0
Above 960	54.0

5.6.2. Method of Measurements

Refer to Ultratech Test Procedures ULTR-P001-200 & ANSI C63.4 for method of measurements.

The spectrum shall be investigated from the lowest radio frequency signal generated or used in the device, without going below the lowest frequency for which a radiated emission limit is specified, up to the frequency shown in the following table:

Highest frequency generated or used in the device or on which the device operates or tunes (MHz)	Upper frequency of measurement range (MHz)
Below 1.705	30
1.705 - 108	1000
108 – 500	2000
500 -1000	5000
Above 1000	5 th harmonic of the highest frequency or 40 GHz, whichever is lower

5.6.3. Test Arrangement

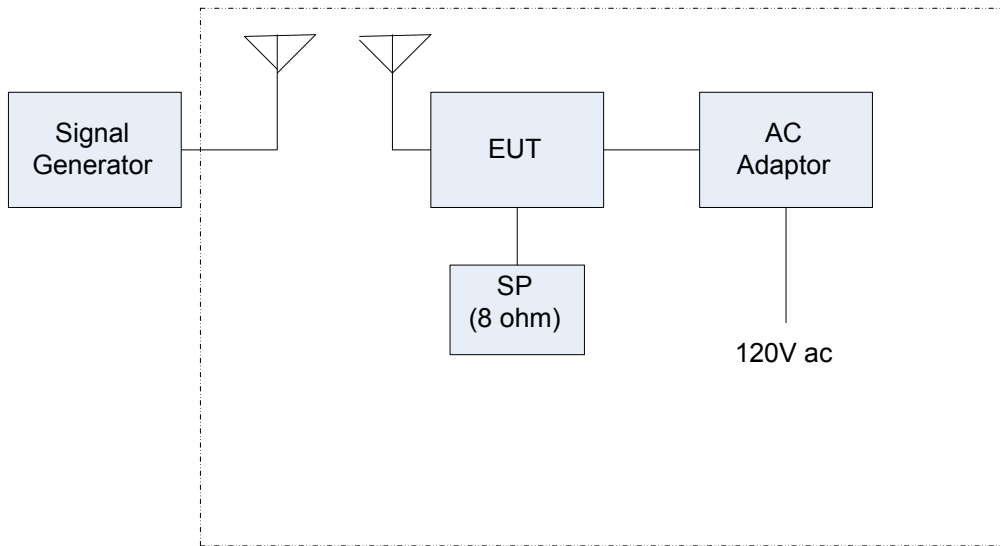

Setup for spurious Radiated Emissions from receiver

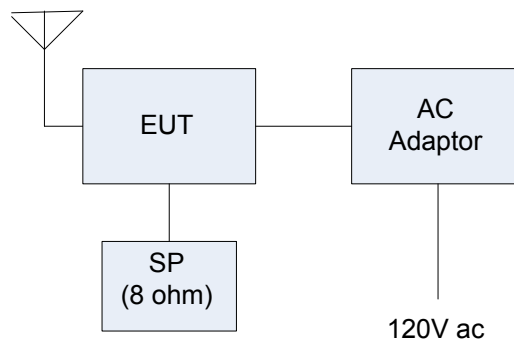

Setup for Unintentional Radiated Emissions from Digital devices

5.6.4. Test Data

5.6.4.1. Near Lowest Frequency (30 MHz)

The emissions were scanned from 30 MHz to 6GHz at 3 Meters distance and all emissions less than 20 dB below the limits were recorded.

FREQUENCY (MHz)	RF LEVEL (dBuV/m)	DETECTOR USED (PEAK/QP)	ANTENNA PLANE (H/V)	LIMIT (dBuV/m)	MARGIN (dB)	PASS/ FAIL
No signal found. All the measurements were at least 20 dB below the limits.						

5.6.4.2. Near Middle Frequency (650 MHz)

The emissions were scanned from 30 MHz to 6GHz at 3 Meters distance and all emissions less than 20 dB below the limits were recorded.

FREQUENCY (MHz)	RF LEVEL (dBuV/m)	DETECTOR USED (PEAK/QP)	ANTENNA PLANE (H/V)	LIMIT (dBuV/m)	MARGIN (dB)	PASS/ FAIL
No signal found. All the measurements were at least 20 dB below the limits.						

5.6.4.3. Near Highest Frequency (960 MHz)

The emissions were scanned from 30 MHz to 6GHz at 3 Meters distance and all emissions less than 20 dB below the limits were recorded.

FREQUENCY (MHz)	RF LEVEL (dBuV/m)	DETECTOR USED (PEAK/QP)	ANTENNA PLANE (H/V)	LIMIT (dBuV/m)	MARGIN (dB)	PASS/ FAIL
No signal found. All the measurements were at least 20 dB below the limits.						

5.6.4.4. Class B Digital Devices

The emissions were scanned from 30 MHz to 6GHz at 3 Meters distance and all emissions less than 20 dB below the limits were recorded.

FREQUENCY (MHz)	RF LEVEL (dBuV/m)	DETECTOR USED (PEAK/QP)	ANTENNA PLANE (H/V)	LIMIT (dBuV/m)	MARGIN (dB)	PASS/ FAIL
246.84	28.2	Peak	V	46.0	-17.8	Pass
246.84	26.7	Peak	H	46.0	-19.3	Pass
495.56	31.1	Peak	V	46.0	-14.9	Pass

5.7. REQUIREMENTS FOR SCANNING RECEIVERS [§ 15.121]

5.7.1. FCC Rules

- a. Except as provided in paragraph (c) of this section, scanning receivers and frequency converters designed or marketed for use with scanning receivers, shall:
 - (1) Be incapable of operating (tuning), or readily being altered by the user to operate, within the frequency bands allocated to the Cellular Radiotelephone Service in part 22 of this chapter (cellular telephone bands). Scanning receivers capable of "readily being altered by the user" include, but are not limited to, those for which the ability to receive transmissions in the cellular telephone bands can be added by clipping the leads of, or installing, a simple component such as a diode, resistor or jumper wire; replacing a plug-in semiconductor chip; or programming a semiconductor chip using special access codes or an external device, such as a personal computer. Scanning receivers, and frequency converters designed for use with scanning receivers, also shall be incapable of converting digital cellular communication transmissions to analog voice audio.
 - (2) Be designed so that the tuning, control and filtering circuitry is inaccessible. The design must be such that any attempts to modify the equipment to receive transmissions from the Cellular Radiotelephone Service likely will render the receiver inoperable.
- b. Except as provided in paragraph (c) of this section, scanning receivers shall reject any signals from the Cellular Radiotelephone Service frequency bands that are 38 dB or lower based upon a 12 dB SINAD measurement, which is considered the threshold where a signal can be clearly discerned from any interference that may be present.
- c. Scanning receivers and frequency converters designed or marketed for use with scanning receivers, are not subject to the requirements of paragraphs (a) and (b) of this section provided that they are manufactured exclusively for, and marketed exclusively to, entities described in 18 U.S.C. 2512(2), or are marketed exclusively as test equipment pursuant to Sec. 15.3(dd)
- d. Modification of a scanning receiver to receive transmissions from Cellular Radiotelephone Service frequency bands will be considered to constitute manufacture of such equipment. This includes any individual, individuals, entity or organization that modifies one or more scanners. Any modification to a scanning receiver to receive transmissions from the Cellular Radiotelephone Service frequency bands voids the certification of the scanning receiver, regardless of the date of manufacture of the original unit. In addition, the provisions of Sec. 15.23 shall not be interpreted as permitting modification of a scanning receiver to receiver cellular radiotelephone service transmissions.
- e. Scanning receivers and frequency converters designed for use with scanning receivers shall not be assembled from kits or marketed in kit form unless they comply with the requirements in paragraph (a) through (c) of this section.

- f. Scanning receivers shall have a label permanently affixed to the product, and this label shall be readily visible to the purchaser at the time of purchase. The label shall read as follows: WARNING: MODIFICATION OF THIS DEVICE TO RECEIVE CELLULAR RADIOTELEPHONE SERVICE SIGNALS IS PROHIBITED UNDER FCC RULES AND FEDERAL LAW.
- (1) ``Permanently affixed" means that the label is etched, engraved, stamped, silkscreened, indelible printed or otherwise permanently marked on a permanently attached part of the equipment or on a nameplate of metal, plastic or other material fastened to the equipment by welding, riveting, or permanent adhesive. The label shall be designed to last the expected lifetime of the equipment in the environment in which the equipment may be operated and must not be readily detachable. The label shall not be a stick-on, paper label.
 - (2) When the device is so small that it is not practicable to place the warning label on it, the information required by this paragraph shall be placed in a prominent location in the instruction manual or pamphlet supplied to the user and shall also be placed on the container in which the device is marketed. However, the FCC identifier must be displayed on the device.

5.7.2. Declaration for Compliance with FCC §15.121

- Comply with FCC 121(a)(1) – This Scanning Receiver is incapable of operating (tuning), or readily being altered by the user to operate, within the frequency bands allocated to the Cellular Radiotelephone Service in part 22 of this chapter (cellular telephone bands).

Please refer to ICOM attestation letter conforming compliance with this requirement.

- Comply with FCC 121(a)(2) – This Scanning Receiver is designed so that the tuning, control and filtering circuitry is inaccessible. The design is such that any attempts to modify the equipment to receive transmissions from the Cellular Radiotelephone Service likely will render the receiver inoperable.

Please refer to ICOM attestation letter conforming compliance with this requirement.

- Comply with FCC 121(b) – Please refer to the following Section of this Test Report for Scanning Receivers Cellular Band Rejection test.
- Comply with FCC 121(c) – Not applicable.
- Comply with FCC 121(d) – The Users Manual of this Scanning Receiver is provided with the Warning statement as below.

Warning: Modifications not expressly approved by ICOM Inc., could void the user’s authority to operate this device under FCC regulations.

- Comply with FCC 121(e) – This Scanning Receiver is not assembled from kits or marketed in kit form.
- Comply with FCC 121(f) – This device is so small that it is not practicable to place the warning label on it. Hence the information required by this paragraph is placed on front page of the user manual supplied to the user and will also be placed on the container in which the device is marketed.. The label reads as follows:
WARNING: MODIFICATION OF THIS DEVICE TO RECEIVE CELLULAR RADIOTELEPHONE SERVICE SIGNALS IS PROHIBITED UNDER FCC RULES AND FEDERAL LAW.

5.8. SCANNING RECEIVERS CELLULAR BAND REJECTION [§ 15.121(b)]

5.8.1. Limits

Except as provided in paragraph (c) of this section, scanning receivers shall reject any signals from the Cellular Radiotelephone Service frequency bands that are 38dB or lower based upon a 12dB SINAD measurement, which is considered the threshold where a signal can be clearly discerned from any interference that may be present.

5.8.2. Method of Measurements

- (1) Connected the EUT as shown in the following block diagram
- (2) Apply a standard RF signal to the receiver input port
- (3) Adjust the audio output signal of the receiver to it's rated value with the distortion less than 10%
- (4) Adjust the RF Signal Generator Output Power to produce 12 dB SINAD without the audio output power dropping by more than 3 dB
- (5) Repeat step (4) at lowest, middle and highest channel frequencies across all cellular base station band to establish a reference sensitivity level. The reference sensitivity taken was the lowest or worse-case sensitivity for all of the bands.
- (6) Adjust the RF Signal Generator output to a level of +60 dB above the reference sensitivity obtained in step (5)
- (7) Set the Receiver squelch threshold (the signal required to open the squelch) no greater than +20 dB above the reference sensitivity level.
- (8) Put the receiver in a scanning mode and allow it to scan across it's complete receive range
- (9) If the receiver unsquelched or stopped on any frequency, the display frequency is recorded. The signal generator output level was then adjusted until 12 dB SINAD from the receiver was produced. The signal generator level associated with this response was also noted.
- (10) Repeat this procedure for 3 frequencies in the cellular base station transmit band.
- (11) The difference between the signal generator output for any response recorded and reference sensitivity is the rejection ratio

Cellular band reject test

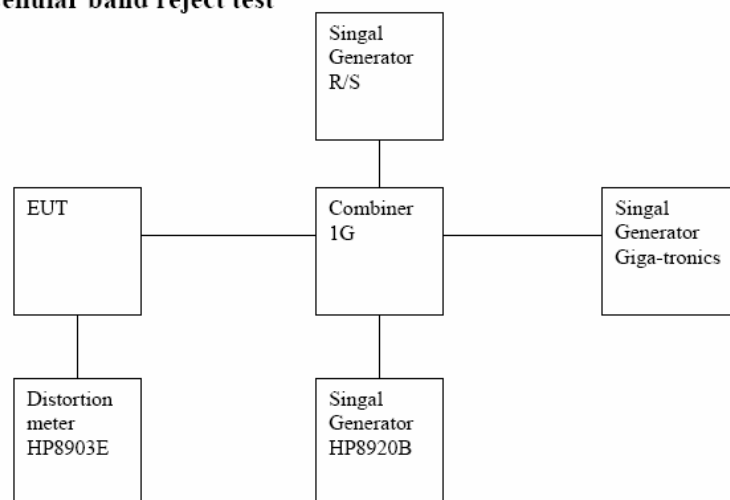

5.8.3. Test Data

5.8.3.1. AM mode

EUT's Scanning Frequency Band & Rx locked frequencies (MHz)	Cellular Transmitter Test Frequencies (MHz)	RF Input Signal Level @ Cellular Frequencies for 12 dB SINAD (dBm)	Sensitivity for 12 dB SINAD (dBm)	Rejection Ratio (dB)	Rejection Ratio Limit (dB)
0.495-30, 118-136, 220-330 & 315.57, 330.0	824.04, 836.40, 848.97, 869.04, 880.62, 893.97	-50	<-99.3	<-49.3	<-38.0

5.8.3.2. FM mode

EUT's Scanning Frequency Band & Rx locked frequencies (MHz)	Cellular Transmitter Test Frequencies (MHz)	RF Input Signal Level @ Cellular Frequencies for 12 dB SINAD (dBm)	Sensitivity for 12 dB SINAD (dBm)	Rejection Ratio (dB)	Rejection Ratio Limit (dB)
1.625-823.995, 851-866.995 & 896-1309.995 & 207.75, 303.2, 315.57, 330, 340, 477.8, 480.57, 490.46, 498.18, 514.21, 855.69, 905.56, 934.96, 957.39, 799.11, 696.97, 1111.365	824.04, 836.40, 848.97, 869.04, 880.62, 893.97	-50	<-98.7	<-48.7	<-38.0

5.8.3.3. WFM mode

EUT's Scanning Frequency Band & Rx locked frequencies (MHz)	Cellular Transmitter Test Frequencies (MHz)	RF Input Signal Level @ Cellular Frequencies for 12 dB SINAD (dBm)	Sensitivity for 12 dB SINAD (dBm)	Rejection Ratio (dB)	Rejection Ratio Limit (dB)
76-108, 175-221 & 470-770 & 493.150	824.04, 836.40, 848.97, 869.04, 880.62, 893.97	-50	<-97	<-47	<-38.0

EXHIBIT 6. TEST EQUIPMENTS LIST

Test Instruments	Manufacturer	Model No.	Serial No.	Frequency Range	Cal. Due Date
Spectrum Analyzer	Rohde & Schwarz	FSU	100398	20Hz – 26.5 GHz	14 Sep 2016
EMI Receiver	Rohde & Schwarz	ESU40	100037	20 Hz - 40 GHz	08 May 2016
Preamplifier	Com-power	PA-103A	161243	10-1000MHz	10 Jun 2016
Pre Amplifier	Com-Power	PA-118A	551016	500 MHz - 18 GHz	06 Jan 2016
Biconilog Antenna	EMCO	3142C	26873	26-3000 MHz	14 Apr 2016
Log Periodic Antenna	ETS	3148	23845	200-2000 MHz	14 Apr 2016
Horn Antenna	EMCO	3115	9911-5955	1GHz - 18 GHz	26 Mar 2016
Combiner	Mini Circuit	ZFSC-3-4	9629 02	1MHz - 1GHz	--
Combiner	Mini Circuit	ZFSC-2-10G	0 9917	1MHz - 1GHz	--
Radio Communication Test Set	HP	8920B	US39064699	30M- 1000MHz	30 Jan 2016
Signal Generator	Rohde & Schwarz	CMS 54	DE22858	300KHz-2.2GHz	27 Mar 2016
Distortion Analyzer	Hewlett-Packard	8903E	3514A01460	20 Hz - 100K Hz	10 Mar 2016
Signal Generator	Marconi Instruments	2024	112255/164	9KHz-2.4GHz	27 Aug 2016
Signal Generator	HP	8648C	3443U00391	100KHz-3.2GHz	02 Feb 2016
Preamplifier	HP	8449B	3008A00769	1-26.5GHz	25 Nov 2015
EMI Receiver	HP	8593EM	3412A00103	9 KHz – 26.5 GHz	09 Apr 2017
Attenuator	Pasternack	PE7010-20	--	DC-2 GHz	03 Feb 2017
LISN	EMCO	3825/2	8907-1531	10 KHz-100 MHz	03 Sep 2016

ULTRATECH GROUP OF LABS

3000 Bristol Circle, Oakville, Ontario, Canada L6H 6G4
 Tel.: 905-829-1570, Fax. : 905-829-8050

File #: 15ICOM408_FCC15C121
 October 26, 2015

All test results contained in this engineering test report are traceable to National Institute of Standards and Technology (NIST)

EXHIBIT 7. MEASUREMENT UNCERTAINTY

The measurement uncertainties stated were calculated in accordance with the requirements of CISPR 16-4-2 @ IEC:2003 and JCGM 100:2008 (GUM 1995) – Guide to the Expression of Uncertainty in Measurement.

7.1. LINE CONDUCTED EMISSION MEASUREMENT UNCERTAINTY

	Line Conducted Emission Measurement Uncertainty (150 kHz – 30 MHz):	Measured	Limit
u_c	Combined standard uncertainty: $u_c(y) = \sqrt{\sum_{i=1}^m u_i^2(y)}$	± 1.57	± 1.8
U	Expanded uncertainty U: $U = 2u_c(y)$	± 3.14	± 3.6

7.2. RADIATED EMISSION MEASUREMENT UNCERTAINTY

	Radiated Emission Measurement Uncertainty @ 3m, Horizontal (30-1000 MHz):	Measured	Limit
u_c	Combined standard uncertainty: $u_c(y) = \sqrt{\sum_{i=1}^m u_i^2(y)}$	± 2.15	± 2.6
U	Expanded uncertainty U: $U = 2u_c(y)$	± 4.30	± 5.2

	Radiated Emission Measurement Uncertainty @ 3m, Vertical (30-1000 MHz):	Measured	Limit
u_c	Combined standard uncertainty: $u_c(y) = \sqrt{\sum_{i=1}^m u_i^2(y)}$	± 2.39	± 2.6
U	Expanded uncertainty U: $U = 2u_c(y)$	± 4.78	± 5.2

	Radiated Emission Measurement Uncertainty @ 3 m, Horizontal & Vertical (1 – 18 GHz):	Measured	Limit
u_c	Combined standard uncertainty: $u_c(y) = \sqrt{\sum_{i=1}^m u_i^2(y)}$	± 1.87	Under consideration
U	Expanded uncertainty U: $U = 2u_c(y)$	± 3.75	Under consideration