

ENGINEERING TEST REPORT

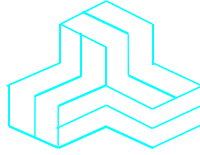

**VHF/UHF Armature Transceiver
Model No.: IC-80AD**

FCC ID: AFJ315500

Applicant:

ICOM Incorporated
1-1-32, Kamiminami, Hirano-ku
Osaka, Japan, 547-0003

Tested in Accordance With

**Federal Communications Commission (FCC)
47 CFR, Part 15, Subpart B
Scanning Receivers Operating in the Frequency Band
30 MHz - 999.990 MHz (excluding cellular bands)**

UltraTech's File No.: ICOM-196F15B121

This Test report is Issued under the Authority of
Tri M. Luu, Professional Engineer,
Vice President of Engineering
UltraTech Group of Labs



Date: February 18, 2009

Report Prepared by: JaeWook Choi

Tested by: Wayne Wu, EMI/RFI Technician

Issued Date: February 18, 2009

Test Dates: February 09, 10, 12 & 13, 2009

- *The results in this Test Report apply only to the sample(s) tested, and the sample tested is randomly selected.*
- *This report must not be used by the client to claim product endorsement by NVLAP or any agency of the US Government.*

UltraTech

3000 Bristol Circle, Oakville, Ontario, Canada, L6H 6G4
Tel.: (905) 829-1570 Fax.: (905) 829-8050

Website: www.ultratech-labs.com, Email: vic@ultratech-labs.com, Email: tri@ultratech-labs.com



0685



31040/SIT



C-1376



46390-2049



200093-0



SL2-IN-E-1119R

**Korea
MIC-RRL**

2005-82 & 83

TABLE OF CONTENTS

EXHIBIT 1. INTRODUCTION	1
1.1. SCOPE.....	1
1.2. RELATED SUBMITTAL(S)/GRANT(S).....	1
1.3. NORMATIVE REFERENCES	1
EXHIBIT 2. PERFORMANCE ASSESSMENT	2
2.1. CLIENT INFORMATION	2
2.2. EQUIPMENT UNDER TEST (EUT) INFORMATION	2
2.3. EUT'S TECHNICAL SPECIFICATIONS	3
2.4. LIST OF EUT'S PORTS.....	3
2.5. ANCILLARY EQUIPMENT	3
2.6. TEST SETUP BLOCK DIAGRAM.....	3
EXHIBIT 3. EUT OPERATING CONDITIONS AND CONFIGURATIONS DURING TESTS	4
3.1. OPERATIONAL TEST CONDITIONS & ARRANGEMENT FOR TEST SIGNALS	4
EXHIBIT 4. SUMMARY OF TEST RESULTS	5
4.1. LOCATION OF TESTS	5
4.2. APPLICABILITY & SUMMARY OF EMC EMISSION TEST RESULTS	5
4.3. MODIFICATIONS REQUIRED FOR COMPLIANCE.....	5
EXHIBIT 5. MEASUREMENTS, EXAMINATIONS & TEST DATA FOR EMC EMISSIONS.....	6
5.1. TEST PROCEDURES	6
5.2. MEASUREMENT UNCERTAINTIES.....	6
5.3. MEASUREMENT EQUIPMENT USED	6
5.4. POWER LINE CONDUCTED EMISSIONS [§ 15.107(A)]	7
5.5. RECEIVER ANTENNA POWER SPURIOUS/HARMONIC CONDUCTED EMISSIONS [§15.111(A)].....	10
5.6. SPURIOUS/HARMONIC RADIATED EMISSIONS FROM RECEIVER AND CLASS B UNINTENTIONAL RADIATORS (DIGITAL DEVICES) [§ 15.109(A)]	15
5.7. REQUIREMENTS FOR SCANNING RECEIVERS [§ 15.121]	19
5.8. SCANNING RECEIVERS CELLULAR BAND REJECTION [§ 15.121(B)]	22
EXHIBIT 6. TEST EQUIPMENTS LIST	28
EXHIBIT 7. MEASUREMENT UNCERTAINTY	30
7.1. LINE CONDUCTED EMISSION MEASUREMENT UNCERTAINTY	30
7.2. RADIATED EMISSION MEASUREMENT UNCERTAINTY	31

EXHIBIT 1. INTRODUCTION

1.1. SCOPE

Reference:	FCC Part 15, Subpart B, Sections 15.107, 15.109, 15.111 & 15.121
Title:	Code of Federal Regulations (CFR), Title 47, Telecommunication, Part 15
Purpose of Test:	To gain FCC Certification Authorization for Scanning Receivers Operating in 30 MHz - 999.990 MHz band (excluding cellular bands).
Test Procedures:	Both conducted and radiated emissions measurements were conducted in accordance with American National Standards Institute ANSI C63.4 - American National Standard for Methods of Measurement of Radio-Noise Emissions from Low-Voltage Electrical and Electronic Equipment in the Range of 9 kHz to 40 GHz.
Environmental Classification:	Residential, Commercial, Industrial or Business environment.

1.2. RELATED SUBMITTAL(S)/GRANT(S)

None.

1.3. NORMATIVE REFERENCES

Publication	Year	Title
FCC CFR Parts 0-19, 80-End	2008	Code of Federal Regulations – Telecommunication
ANSI C63.4	2003	American National Standard for Methods of Measurement of Radio-Noise Emissions from Low-Voltage Electrical and Electronic Equipment in the Range of 9 kHz to 40 GHz
TIA/EIA 603, Edition C	2004	Land Mobile FM or PM Communications Equipment Measurement and Performance Standards

ULTRATECH GROUP OF LABS

3000 Bristol Circle, Oakville, Ontario, Canada L6H 6G4
Tel. #: 905-829-1570, Fax. #: 905-829-8050, Email: vic@ultratech-labs.com, Website: <http://www.ultratech-labs.com>

File #: ICOM-196F15B121

February 18, 2009

All test results contained in this engineering test report are traceable to National Institute of Standards and Technology (NIST)

EXHIBIT 2. PERFORMANCE ASSESSMENT

2.1. CLIENT INFORMATION

APPLICANT	
Name:	Icom Incorporated
Address:	1-1-32, Kamiminami, Hirano-ku, Osaka Japan, 547-0003
Contact Person:	Mr. Yoshiteru Yano Phone #: +81-66-793-5302 Fax #: +81-66-793-0013 Email Address: export@icom.co.jp

MANUFACTURER	
Name:	Icom Incorporated
Address:	1-1-32, Kamiminami, Hirano-ku, Osaka Japan, 547-0003
Contact Person:	Mr. Yoshiteru Yano Phone #: +81-66-793-5302 Fax #: +81-66-793-0013 Email Address: export@icom.co.jp

2.2. EQUIPMENT UNDER TEST (EUT) INFORMATION

The following information (with the exception of the Date of Receipt) has been supplied by the applicant.

Brand Name:	ICOM Incorporated
Product Name:	VHF/UHF Armature Transceiver
Model Name or Number:	IC-80AD
Serial Number:	Test sample
Type of Equipment:	VHF/UHF Armature Transceiver
Power input source:	10.0 – 16.0 V DC for external power, or 7.4 V 1300 mAh Li-ion battery

2.3. EUT'S TECHNICAL SPECIFICATIONS

RECEIVER	
Equipment Type:	Portable
Power Supply Requirement:	10.0 – 16.0 V DC for external power, or 7.4 V 1300 mAh Li-ion battery
Operating Frequency Range:	0.495 – 823.993 MHz, 849 – 868.990 MHz and 894 – 999.990 MHz
Intermediate Frequencies:	1 st 61.65 MHz/59.25 MHz(WFM only), 2 nd 450 kHz/13.35 MHz (WFM only), 3 rd 1.95 MHz (WFM only)
RF Input Impedance:	50 Ω

2.4. LIST OF EUT'S PORTS

Port Number	EUT's Port Description	Number of Identical Ports	Connector Type	Cable Type (Shielded/Non-shielded)
1	ANT	1	SMA	N/A
2	SP/MIC	1	Mini Jack	N/A
3	DATA	1	Mini Jack	N/A
4	DC IN	1	Power Jack	N/A

2.5. ANCILLARY EQUIPMENT

N/A

2.6. TEST SETUP BLOCK DIAGRAM

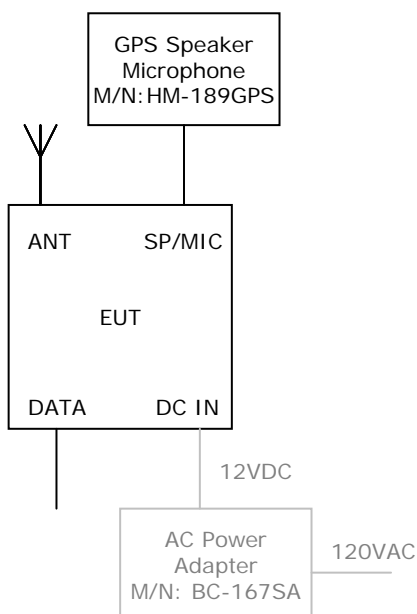

EXHIBIT 3. EUT OPERATING CONDITIONS AND CONFIGURATIONS DURING TESTS

3.1. OPERATIONAL TEST CONDITIONS & ARRANGEMENT FOR TEST SIGNALS

Operating Modes:	The receiver was operated in the normal intended mode during testing
Special Test Software:	None
Special Hardware Used:	None
Receiver Test Antenna:	The EUT was tested with its antenna fitted in normal operation condition

Receiver Test Signals	
Frequency Band(s):	0.495 – 823.993 MHz, 849 – 868.990 MHz and 894 – 999.990 MHz
Test Frequency(ies): (Near lowest, near middle & near highest frequencies in the frequency range of operation.)	30 MHz, 500 MHz, 999.990 MHz

EXHIBIT 4. SUMMARY OF TEST RESULTS

4.1. LOCATION OF TESTS

All of the measurements described in this report were performed at Ultratech Group of Labs located in the city of Oakville, Province of Ontario, Canada.

- Power Line Conducted Emissions were performed in UltraTech's shielded room, 16'(L) by 12'(W) by 12'(H).
- Radiated Emissions were performed at the Ultratech's 3-10 TDK Semi-Anechoic Chamber situated in the Town of Oakville, province of Ontario. This test site been calibrated in accordance with ANSI C63.4, and found to be in compliance with the requirements of Sec. 2.948 of the FCC Rules. The descriptions and site measurement data of the Oakville 3-10 TDK Semi-Anechoic Chamber has been filed with FCC office (FCC File No.: 31040/SIT 1300B3) and Industry Canada office (Industry Canada File No.: IC 2049A-3). Expiry Date of Site Registration is May 17, 2007.

4.2. APPLICABILITY & SUMMARY OF EMC EMISSION TEST RESULTS

FCC Part 15, Subpart B	Test Requirements	Compliance (Yes/No)
15.107(a), Class B	Power Line Conducted Emissions Measurements	Yes
15.111(a)	Receiver Antenna Power Conducted Emissions for Non-Integral Antenna Port	Yes
15.109(a)	Radiated Emissions from Scanning Receivers & Class B Digital Device	Yes
15.121	Requirements for Scanning Receivers	Yes

4.3. MODIFICATIONS REQUIRED FOR COMPLIANCE

None.

EXHIBIT 5. MEASUREMENTS, EXAMINATIONS & TEST DATA FOR EMC EMISSIONS

5.1. TEST PROCEDURES

Please refer to Ultratech Test Procedures, File# ULTR-P001-2004 and for Test Procedures.

5.2. MEASUREMENT UNCERTAINTIES

The measurement uncertainties stated were calculated in accordance with requirements of UKAS Document LAB 34 with a confidence level of 95%. Please refer to EXHIBIT 7. for Measurement Uncertainties.

5.3. MEASUREMENT EQUIPMENT USED

The measurement equipment used complied with the requirements of the Standards referenced in the Methods & Procedures ANSI C63.4 and CIPSR 16-1-1.

5.4. POWER LINE CONDUCTED EMISSIONS [§ 15.107(a)]

5.4.1. Limits

The equipment shall meet the limits of the following table:

Frequency of Emissions (MHz)	Class B Conducted Limit (dB μ V)	
	Quasi-Peak	Average
0.15 to 0.5	66 to 56*	56 to 46*
0.5 to 5	56	46
5 to 30	60	50

* Decreasing linearly with logarithm of frequency

5.4.2. Method of Measurements

Refer to Ultratech Test Procedures ULTR-P001-200 & ANSI C63.4 for method of measurements.

5.4.3. Test Arrangement

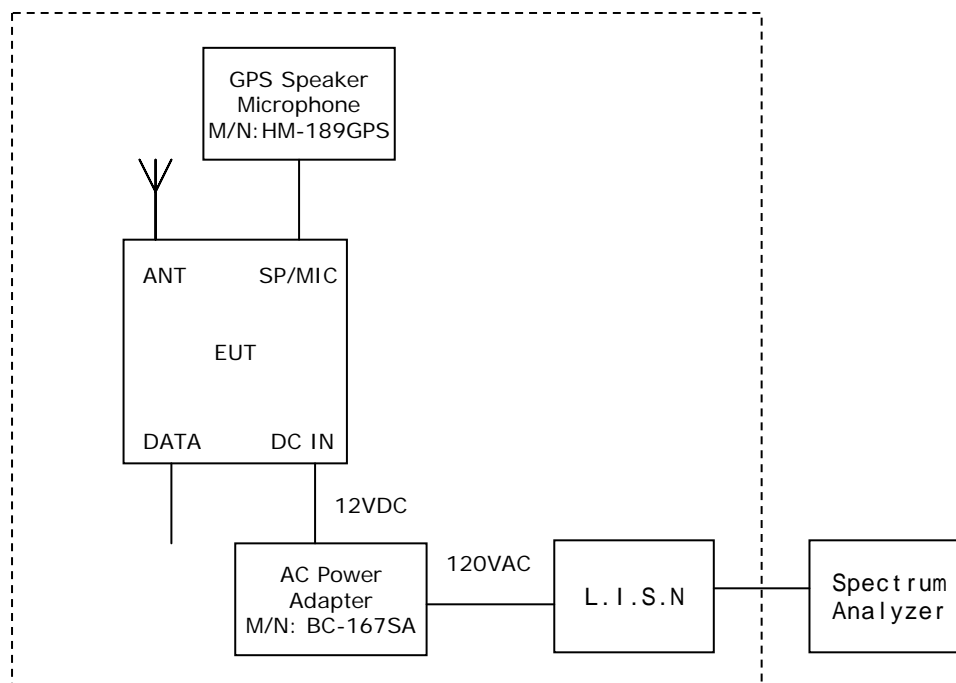

5.4.4. Test Data

< 120 VAC, Line Tested: Neutral >

Current Graph

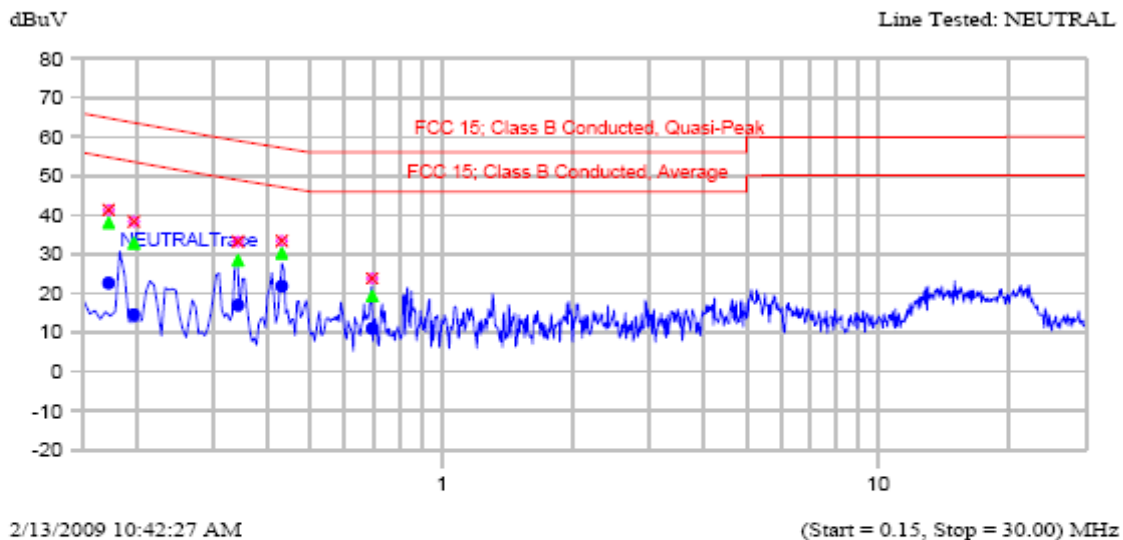

Current List

Frequency MHz	Peak dBuV	QP dBuV	Delta dB	QP-QP Limit dB	Avg dBuV	Delta dB	Avg-Avg Limit dB	Trace Name
0.173	41.3	38.0	-26.8		22.6	-32.2		NEUTRALTrace
0.197	38.4	32.8	-30.9		14.6	-39.1		NEUTRALTrace
0.342	33.2	28.5	-30.7		16.9	-32.2		NEUTRALTrace
0.431	33.4	30.2	-27.0		21.8	-25.4		NEUTRALTrace
0.694	23.8	19.3	-36.7		11.0	-35.0		NEUTRALTrace

< 120 VAC, Line Tested: Hot >

Current Graph

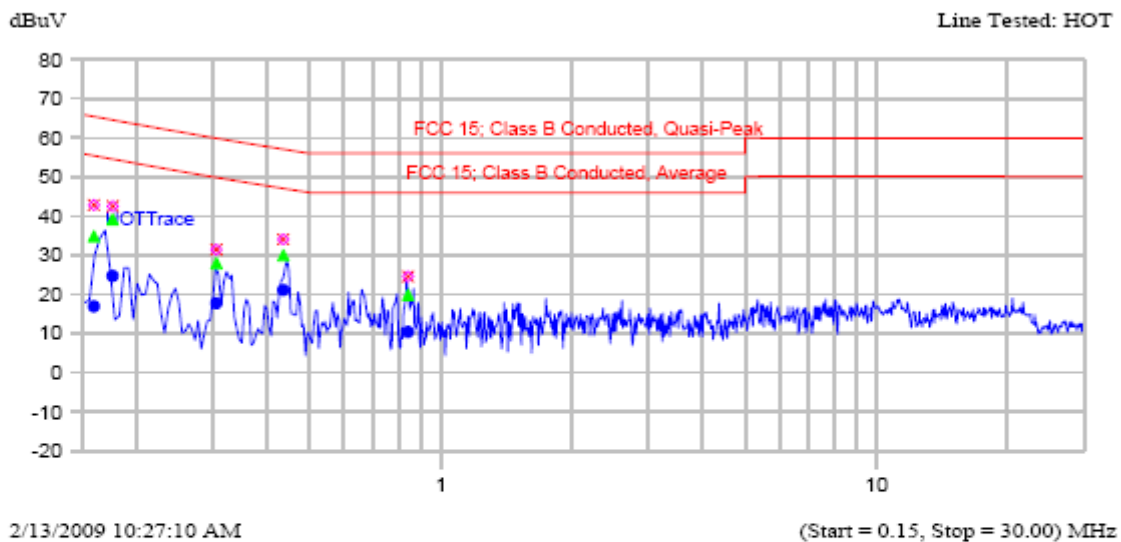

Current List

Frequency MHz	Peak dBuV	QP dBuV	Delta QP-QP Limit dB	Avg dBuV	Delta Avg-Avg Limit dB	Trace Name
0.160	42.8	34.9	-30.6	16.9	-38.6	HOTTrace
0.177	42.5	39.1	-25.5	24.7	-30.0	HOTTrace
0.306	31.4	27.9	-32.1	17.7	-32.3	HOTTrace
0.436	34.1	30.0	-27.1	21.1	-26.1	HOTTrace
0.843	24.6	19.9	-36.1	10.4	-35.6	HOTTrace

5.5. RECEIVER ANTENNA POWER SPURIOUS/HARMONIC CONDUCTED EMISSIONS [§ 15.111(a)]

5.5.1. Limits

Receivers that operate (tune) in the frequency range 30 to 960 Mhz and CB receivers that provides terminals for the connection of an external antenna may be tested to demonstrate compliance with the provisions of @ 15.109 with the antenna terminals shielded and terminated with a resistive termination equal to the impedance specified for the antenna, provided these receivers also comply with the following:- ***With the receiver antenna terminal connected to a resistive termination equal to the impedance specified or employed for the antenna, the power at the antenna terminal at frequency within the range from 30 Mhz to 5th harmonic of the highest frequency shall not exceed 2.0 nanowatts (or -57 dBm @ 50 Ohm).***

5.5.2. Method of Measurements

Refer to Ultratech Test Procedures ULTR-P001-200 & ANSI C63.4 for method of measurements.

The spectrum shall be investigated from the lowest radio frequency signal generated or used in the device, without going below the lowest frequency for which a radiated emission limit is specified, up to the frequency shown in the following table:

Highest frequency generated or used in the device or on which the device operates or tunes (MHz)	Upper frequency of measurement range (MHz)
Below 1.705	30
1.705 - 108	1000
108 – 500	2000
500 -1000	5000
Above 1000	5 th harmonic of the highest frequency or 40 GHz, whichever is lower

5.5.3. Test Arrangement

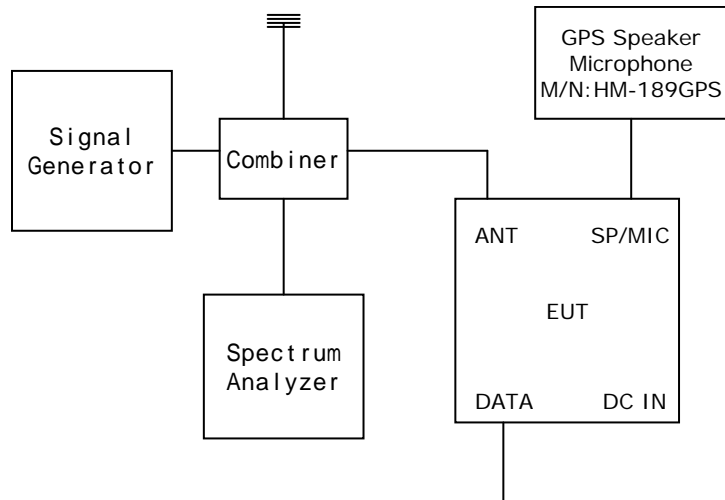

5.5.4. Test Data

5.5.4.1. Near Lowest Frequency (30 MHz, 60 dBuV CW input)

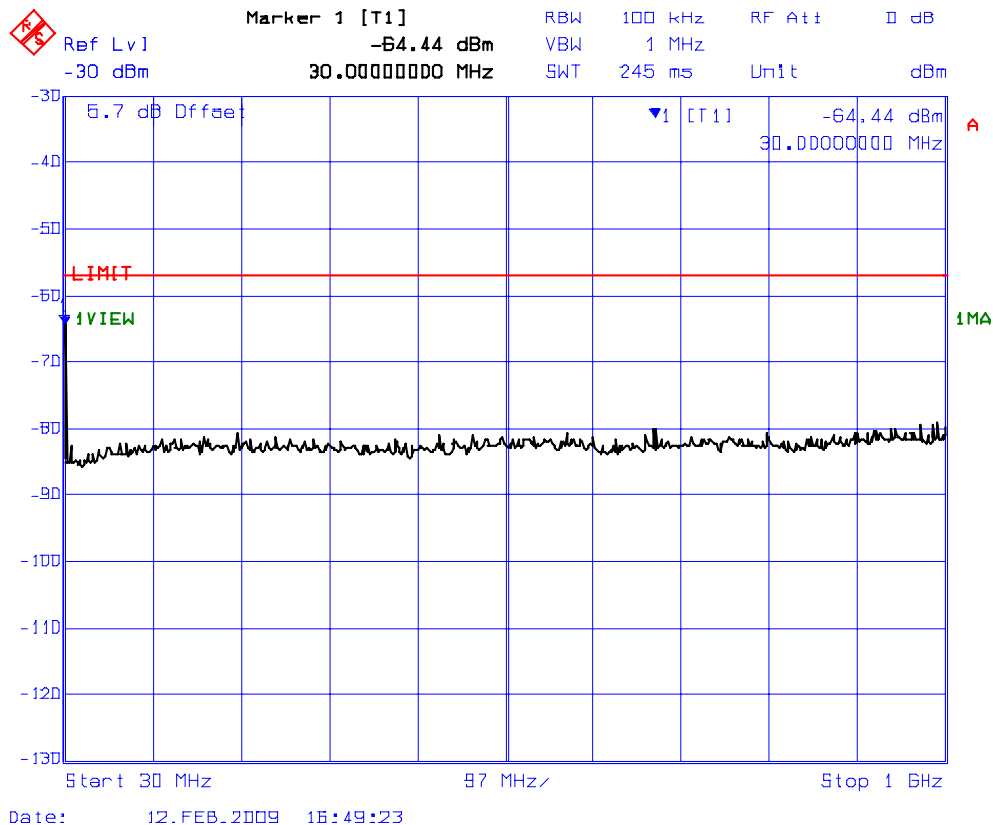

ULTRATECH GROUP OF LABS

3000 Bristol Circle, Oakville, Ontario, Canada L6H 6G4
Tel. #: 905-829-1570, Fax. #: 905-829-8050, Email: vic@ultratech-labs.com, Website: <http://www.ultratech-labs.com>

File #: ICOM-196F15B121

February 18, 2009

All test results contained in this engineering test report are traceable to National Institute of Standards and Technology (NIST)

5.5.4.2. Near Middle Frequency (500 MHz, 60 dBuV CW input)

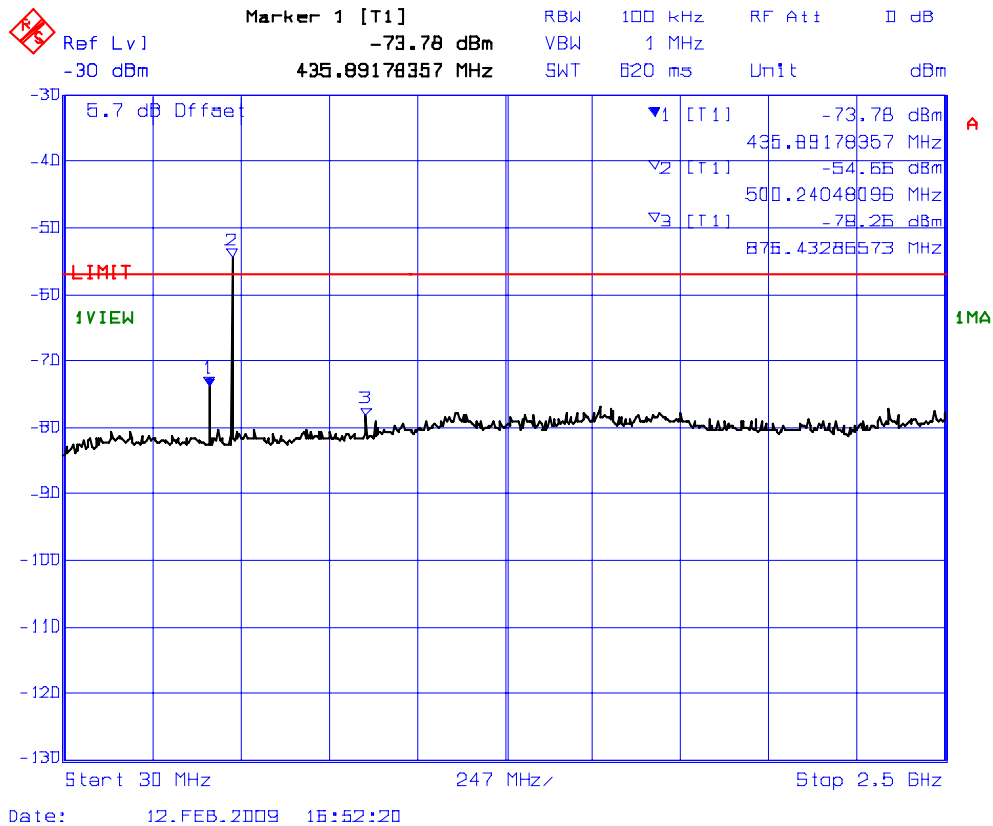

ULTRATECH GROUP OF LABS

3000 Bristol Circle, Oakville, Ontario, Canada L6H 6G4
Tel. #: 905-829-1570, Fax. #: 905-829-8050, Email: vic@ultratech-labs.com, Website: <http://www.ultratech-labs.com>

File #: ICOM-196F15B121

February 18, 2009

All test results contained in this engineering test report are traceable to National Institute of Standards and Technology (NIST)

5.5.4.3. Near Highest Frequency (999.99 MHz, 60 dBuV CW input)

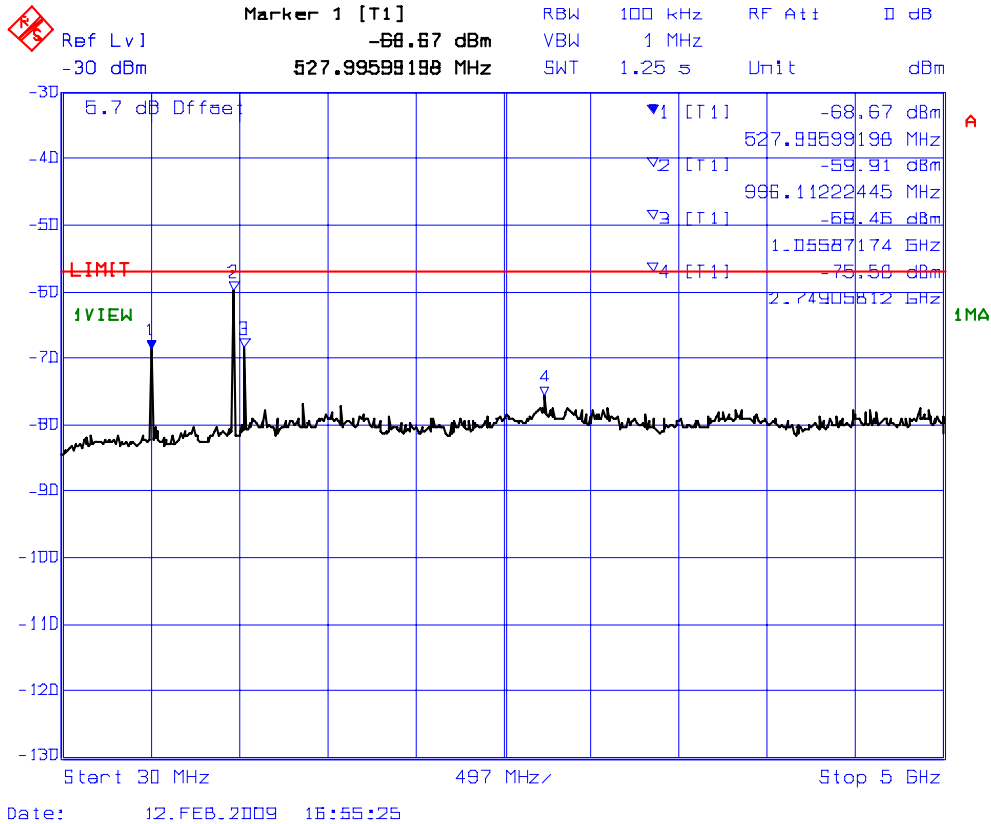

ULTRATECH GROUP OF LABS

3000 Bristol Circle, Oakville, Ontario, Canada L6H 6G4
 Tel. #: 905-829-1570, Fax. #: 905-829-8050, Email: vic@ultratech-labs.com, Website: <http://www.ultratech-labs.com>

File #: ICOM-196F15B121

February 18, 2009

All test results contained in this engineering test report are traceable to National Institute of Standards and Technology (NIST)

5.6. SPURIOUS/HARMONIC RADIATED EMISSIONS FROM RECEIVER AND CLASS B UNINTENTIONAL RADIATORS (§ 15.109(a))

5.6.1. Limits

The equipment shall meet the limits of the following table:

Test Frequency Range (MHz)	Class B Limits @ 3 m (dB μ V/m)
30 – 88	40.0
88 – 216	43.5
216 – 960	46.0
Above 960	54.0

5.6.2. Method of Measurements

Refer to Ultratech Test Procedures ULTR-P001-200 & ANSI C63.4 for method of measurements.

The spectrum shall be investigated from the lowest radio frequency signal generated or used in the device, without going below the lowest frequency for which a radiated emission limit is specified, up to the frequency shown in the following table:

Highest frequency generated or used in the device or on which the device operates or tunes (MHz)	Upper frequency of measurement range (MHz)
Below 1.705	30
1.705 - 108	1000
108 – 500	2000
500 -1000	5000
Above 1000	5 th harmonic of the highest frequency or 40 GHz, whichever is lower

5.6.3. Test Arrangement

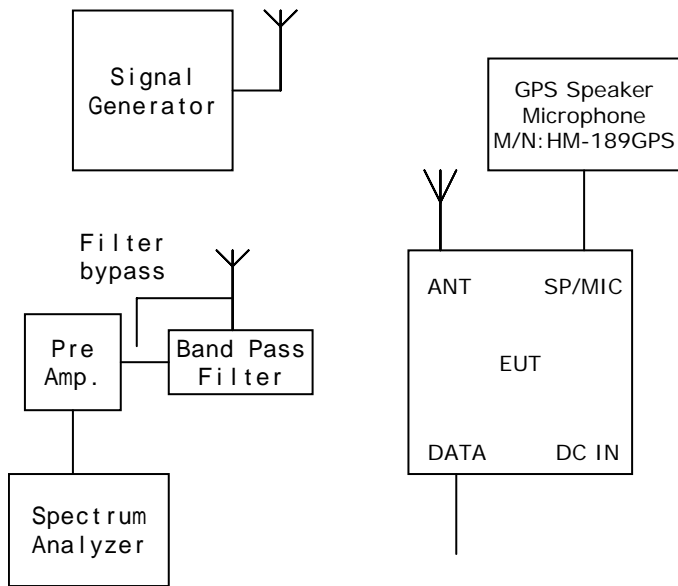

< Receiver mode >

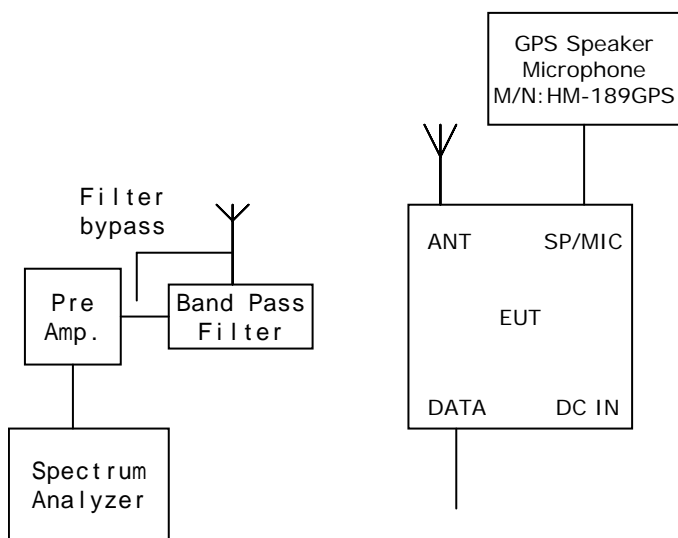

< Digital Device >

5.6.4. Test Data

5.6.4.1. Near Lowest Frequency, FM mode (30 MHz, 60dBuV, $Lo = Rx + IF = 30 + 61.65 = 91.65$ MHz)

The emissions were scanned from 30 MHz to 5th harmonic of Lo at 3 Meters distance and all emissions within 20 dB of the specified limits have been reported unless otherwise specified.

FREQUENCY (MHz)	RF LEVEL (dBuV/m)	DETECTOR USED (PEAK/QP)	ANTENNA PLANE (H/V)	LIMIT (dBuV/m)	MARGIN (dB)	PASS/ FAIL
No signal found.						

5.6.4.2. Near Middle Frequency, FM mode (500 MHz, 60dBuV, $Lo = Rx - IF = 500 + 61.65 = 438.35$ MHz)

The emissions were scanned from 30 MHz to 5th harmonic of Lo at 3 Meters distance and all emissions within 20 dB of the specified limits have been reported unless otherwise specified.

FREQUENCY (MHz)	RF LEVEL (dBuV/m)	DETECTOR USED (PEAK/QP)	ANTENNA PLANE (H/V)	LIMIT (dBuV/m)	MARGIN (dB)	PASS/ FAIL
No signal found.						

5.6.4.3. Near Middle Frequency, WFM mode (500 MHz, 60dBuV, $Lo = Rx - IF = 500 + 59.25 = 440.75$ MHz)

The emissions were scanned from 30 MHz to 5th harmonic of Lo at 3 Meters distance and all emissions within 20 dB of the specified limits have been reported unless otherwise specified.

FREQUENCY (MHz)	RF LEVEL (dBuV/m)	DETECTOR USED (PEAK/QP)	ANTENNA PLANE (H/V)	LIMIT (dBuV/m)	MARGIN (dB)	PASS/ FAIL
No signal found.						

5.6.4.4. Near Highest Frequency, FM mode (999.99 MHz, 60dBuV, $Lo = Rx - IF = 999.99 + 61.65 = 1061.64$ MHz)

The emissions were scanned from 30 MHz to 5th harmonic of Lo at 3 Meters distance and all emissions within 20 dB of the specified limits have been reported unless otherwise specified.

FREQUENCY (MHz)	RF LEVEL (dBuV/m)	DETECTOR USED (PEAK/QP)	ANTENNA PLANE (H/V)	LIMIT (dBuV/m)	MARGIN (dB)	PASS/ FAIL
No signal found.						

5.6.4.5. Class B Digital Devices

The emissions were scanned from 30 MHz to 6 GHz at 3 Meters distance and all emissions within 20 dB of the specified limits have been reported unless otherwise specified.

FREQUENCY (MHz)	RF LEVEL (dBuV/m)	DETECTOR USED (PEAK/QP)	ANTENNA PLANE (H/V)	LIMIT (dBuV/m)	MARGIN (dB)	PASS/ FAIL
79.000	34.35	PEAK	V	40.00	-5.65	PASS
79.000	27.43	PEAK	H	40.00	-12.57	PASS
81.000	33.01	PEAK	V	40.00	-6.99	PASS
81.000	25.70	PEAK	V	40.00	-14.30	PASS
84.300	30.66	PEAK	H	40.00	-9.34	PASS
84.300	23.33	PEAK	V	40.00	-16.67	PASS
89.500	29.49	PEAK	H	43.50	-14.01	PASS
89.500	22.11	PEAK	V	43.50	-21.39	PASS
91.500	28.46	PEAK	H	43.50	-15.04	PASS
91.500	20.38	PEAK	V	43.50	-23.12	PASS
94.800	26.86	PEAK	H	43.50	-16.64	PASS
94.800	18.94	PEAK	V	43.50	-24.56	PASS
100.000	29.76	PEAK	V	43.50	-13.74	PASS
100.000	20.27	PEAK	V	43.50	-23.23	PASS
105.300	28.42	PEAK	V	43.50	-15.08	PASS
105.300	20.20	PEAK	V	43.50	-23.30	PASS
110.500	32.04	PEAK	H	43.50	-11.46	PASS
112.500	31.27	PEAK	V	43.50	-12.23	PASS
115.800	28.87	PEAK	H	43.50	-14.63	PASS
121.300	29.11	PEAK	V	43.50	-14.39	PASS
121.300	19.48	PEAK	H	43.50	-24.02	PASS
123.300	28.46	PEAK	V	43.50	-15.04	PASS
133.400	30.09	PEAK	V	43.50	-13.41	PASS
133.400	21.98	PEAK	H	43.50	-21.52	PASS
136.800	32.06	PEAK	V	43.50	-11.44	PASS
136.800	23.89	PEAK	H	43.50	-19.61	PASS
139.400	31.08	PEAK	V	43.50	-12.42	PASS
139.400	21.57	PEAK	H	43.50	-21.93	PASS
395.000	29.52	PEAK	V	46.00	-16.48	PASS
395.000	34.20	PEAK	H	46.00	-11.80	PASS
790.300	35.00	PEAK	H	46.00	-11.00	PASS

ULTRATECH GROUP OF LABS

3000 Bristol Circle, Oakville, Ontario, Canada L6H 6G4
Tel. #: 905-829-1570, Fax. #: 905-829-8050, Email: vic@ultratech-labs.com, Website: <http://www.ultratech-labs.com>

File #: ICOM-196F15B121

February 18, 2009

All test results contained in this engineering test report are traceable to National Institute of Standards and Technology (NIST)

5.7. REQUIREMENTS FOR SCANNING RECEIVERS [§ 15.121]

5.7.1. FCC Rules

- a. Except as provided in paragraph (c) of this section, scanning receivers and frequency converters designed or marketed for use with scanning receivers, shall:
 - (1) Be incapable of operating (tuning), or readily being altered by the user to operate, within the frequency bands allocated to the Cellular Radiotelephone Service in part 22 of this chapter (cellular telephone bands). Scanning receivers capable of "readily being altered by the user" include, but are not limited to, those for which the ability to receive transmissions in the cellular telephone bands can be added by clipping the leads of, or installing, a simple component such as a diode, resistor or jumper wire; replacing a plug-in semiconductor chip; or programming a semiconductor chip using special access codes or an external device, such as a personal computer. Scanning receivers, and frequency converters designed for use with scanning receivers, also shall be incapable of converting digital cellular communication transmissions to analog voice audio.
 - (2) Be designed so that the tuning, control and filtering circuitry is inaccessible. The design must be such that any attempts to modify the equipment to receive transmissions from the Cellular Radiotelephone Service likely will render the receiver inoperable.
- b. Except as provided in paragraph (c) of this section, scanning receivers shall reject any signals from the Cellular Radiotelephone Service frequency bands that are 38 dB or lower based upon a 12 dB SINAD measurement, which is considered the threshold where a signal can be clearly discerned from any interference that may be present.
- c. Scanning receivers and frequency converters designed or marketed for use with scanning receivers, are not subject to the requirements of paragraphs (a) and (b) of this section provided that they are manufactured exclusively for, and marketed exclusively to, entities described in 18 U.S.C. 2512(2), or are marketed exclusively as test equipment pursuant to Sec. 15.3(dd)
- d. Modification of a scanning receiver to receive transmissions from Cellular Radiotelephone Service frequency bands will be considered to constitute manufacture of such equipment. This includes any individual, individuals, entity or organization that modifies one or more scanners. Any modification to a scanning receiver to receive transmissions from the Cellular Radiotelephone Service frequency bands voids the certification of the scanning receiver, regardless of the date of manufacture of the original unit. In addition, the provisions of Sec. 15.23 shall not be interpreted as permitting modification of a scanning receiver to receive cellular radiotelephone service transmissions.
- e. Scanning receivers and frequency converters designed for use with scanning receivers shall not be assembled from kits or marketed in kit form unless they comply with the requirements in paragraph (a) through (c) of this section.

- f. Scanning receivers shall have a label permanently affixed to the product, and this label shall be readily visible to the purchaser at the time of purchase. The label shall read as follows: WARNING: MODIFICATION OF THIS DEVICE TO RECEIVE CELLULAR RADIOTELEPHONE SERVICE SIGNALS IS PROHIBITED UNDER FCC RULES AND FEDERAL LAW.
- (1) ``Permanently affixed" means that the label is etched, engraved, stamped, silkscreened, indelible printed or otherwise permanently marked on a permanently attached part of the equipment or on a nameplate of metal, plastic or other material fastened to the equipment by welding, riveting, or permanent adhesive. The label shall be designed to last the expected lifetime of the equipment in the environment in which the equipment may be operated and must not be readily detachable. The label shall not be a stick-on, paper label.
 - (2) When the device is so small that it is not practicable to place the warning label on it, the information required by this paragraph shall be placed in a prominent location in the instruction manual or pamphlet supplied to the user and shall also be placed on the container in which the device is marketed. However, the FCC identifier must be displayed on the device.

5.7.2. Declaration for Compliance with FCC §15.121

- Comply with FCC 121(a)(1) – This Scanning Receiver is incapable of operating (tuning), or readily being altered by the user to operate, within the frequency bands allocated to the Cellular Radiotelephone Service in part 22 of this chapter (cellular telephone bands).

Please refer to ICOM attestation letter conforming compliance with this requirement.

- Comply with FCC 121(a)(2) – This Scanning Receiver is designed so that the tuning, control and filtering circuitry is inaccessible. The design is such that any attempts to modify the equipment to receive transmissions from the Cellular Radiotelephone Service likely will render the receiver inoperable.

Please refer to ICOM attestation letter conforming compliance with this requirement.

- Comply with FCC 121(b) – Please refer to the following Section of this Test Report for Scanning Receivers Cellular Band Rejection test.
- Comply with FCC 121(c) – Not applicable.
- Comply with FCC 121(d) – The Users Manual of this Scanning Receiver is provided with the Warning statement as below.

Warning: Modifications not expressly approved by ICOM Inc., could void the user’s authority to operate this device under FCC regulations.

- Comply with FCC 121(e) – This Scanning Receiver is not assembled from kits or marketed in kit form.
- Comply with FCC 121(f) – Scanning receivers shall have a label permanently affixed to the product, and this label shall be readily visible to the purchaser at the time of purchase. The label reads as follows: **WARNING: MODIFICATION OF THIS DEVICE TO RECEIVE CELLULAR RADIOTELEPHONE SERVICE SIGNALS IS PROHIBITED UNDER FCC RULES AND FEDERAL LAW.**

5.8. SCANNING RECEIVERS CELLULAR BAND REJECTION [§ 15.121(b)]

5.8.1. Limits

Except as provided in paragraph (c) of this section, scanning receivers shall reject any signals from the Cellular Radiotelephone Service frequency bands that are 38dB or lower based upon a 12dB SINAD measurement, which is considered the threshold where a signal can be clearly discerned from any interference that may be present.

5.8.2. Method of Measurements

- (1) Connected the EUT as shown in the following block diagram
- (2) Apply a standard RF signal to the receiver input port
- (3) Adjust the audio output signal of the receiver to it's rated value with the distortion less than 10%
- (4) Adjust the RF Signal Generator Output Power to produce 12 dB SINAD without the audio output power dropping by more than 3 dB
- (5) Repeat step (4) at lowest, middle and highest channel frequencies across all cellular base station band to establish a reference sensitivity level. The reference sensitivity taken was the lowest or worse-case sensitivity for all of the bands.
- (6) Adjust the RF Signal Generator output to a level of +60 dB above the reference sensitivity obtained in step (5)
- (7) Set the Receiver squelch threshold (the signal required to open the squelch) no greater than +20 dB above the reference sensitivity level.
- (8) Put the receiver in a scanning mode and allow it to scan across it's complete receive range
- (9) If the receiver unsquelched or stopped on any frequency, the display frequency is recorded. The signal generator output level was then adjusted until 12 dB SINAD from the receiver was produced. The signal generator level associated with this response was also noted.
- (10) Repeat this procedure for 3 frequencies in the cellular base station transmit band.
- (11) The difference between the signal generator output for any response recorded and reference sensitivity is the rejection ratio

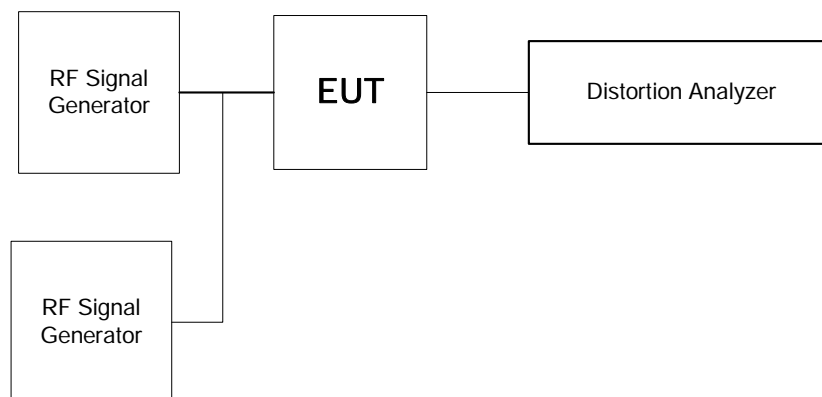

5.8.3. Test Data

5.8.3.1. DV mode

EUT's Scanning Frequency Band (MHz)	Cellular Transmitter Test Frequencies (MHz)	RF Input Signal Level @ Cellular Frequencies for 12 dB SINAD (dBm)	Reference Sensitivity (dBm)	Rejection Ratio (dB)	Maximum Rejection Ratio Limit (dB)
No signal found in scanning across complete receiver range from ANT, -40 dBm input Cellular Transmitter Test frequencies are 824.04, 836.40, 848.97, 869.04, 880.62 and 893.97 MHz					

5.8.3.2. AM mode

EUT's Scanning Frequency Band (MHz)	Cellular Transmitter Test Frequencies (MHz)	RF Input Signal Level @ Cellular Frequencies for 12 dB SINAD (dBm)	Reference Sensitivity (dBm)	Rejection Ratio (dB)	Maximum Rejection Ratio Limit (dB)
15.30	824.04, 836.40, 848.97, 869.04, 880.62, 893.97	-40	-100.4	> 50	38.0
61.20	824.04, 836.40, 848.97, 869.04, 880.62, 893.97	-40	-96.4	> 50	38.0
91.80	824.04, 836.40, 848.97, 869.04, 880.62, 893.97	-40	-97.5	> 50	38.0
102.75	824.04, 836.40, 848.97, 869.04, 880.62, 893.97	-40	-105.7	> 50	38.0
107.10	824.04, 836.40, 848.97, 869.04, 880.62, 893.97	-40	-98.3	> 50	38.0
137.70	824.04, 836.40, 848.97, 869.04, 880.62, 893.97	-40	-101.2	> 50	38.0
321.30	824.04, 836.40, 848.97, 869.04, 880.62, 893.97	-40	-103.6	> 50	38.0
737.97	824.04, 836.40, 848.97, 869.04, 880.62, 893.97	-40	-103.2	> 50	38.0
776.20	824.04, 836.40, 848.97, 869.04, 880.62, 893.97	-40	-103.2	> 50	38.0
781.54	824.04, 836.40, 848.97, 869.04, 880.62, 893.97	-40	-103.1	> 50	38.0
796.05	824.04, 836.40, 848.97, 869.04, 880.62, 893.97	-40	-99.3	> 50	38.0
855.69	824.04, 836.40, 848.97, 869.04, 880.62, 893.97	-40	-99.0	> 50	38.0
857.46	824.04, 836.40, 848.97, 869.04, 880.62, 893.97	-40	-99.1	> 50	38.0
865.59	824.04, 836.40, 848.97, 869.04, 880.62, 893.97	-40	-100.5	> 50	38.0
907.32	824.04, 836.40, 848.97, 869.04, 880.62, 893.97	-40	-99.9	> 50	38.0
917.13	824.04, 836.40, 848.97, 869.04, 880.62, 893.97	-40	-100.1	> 50	38.0
956.80	824.04, 836.40, 848.97, 869.04, 880.62, 893.97	-40	-99.6	> 50	38.0
961.17	824.04, 836.40, 848.97, 869.04, 880.62, 893.97	-40	-98.7	> 50	38.0
966.51	824.04, 836.40, 848.97, 869.04, 880.62, 893.97	-40	-97.1	> 50	38.0

ULTRATECH GROUP OF LABS

3000 Bristol Circle, Oakville, Ontario, Canada L6H 6G4
Tel. #: 905-829-1570, Fax. #: 905-829-8050, Email: vic@ultratech-labs.com, Website: <http://www.ultratech-labs.com>

File #: ICOM-196F15B121
February 18, 2009

All test results contained in this engineering test report are traceable to National Institute of Standards and Technology (NIST)

5.8.3.3. FM mode

EUT's Scanning Frequency Band (MHz)	Cellular Transmitter Test Frequencies (MHz)	RF Input Signal Level @ Cellular Frequencies for 12 dB SINAD (dBm)	Reference Sensitivity (dBm)	Rejection Ratio (dB)	Maximum Rejection Ratio Limit (dB)
15.30	824.04, 836.40, 848.97, 869.04, 880.62, 893.97	-40	-105.2	> 50	38.0
61.20	824.04, 836.40, 848.97, 869.04, 880.62, 893.97	-40	-97.3	> 50	38.0
91.80	824.04, 836.40, 848.97, 869.04, 880.62, 893.97	-40	-100.5	> 50	38.0
102.75	824.04, 836.40, 848.97, 869.04, 880.62, 893.97	-40	-109.7	> 50	38.0
107.10	824.04, 836.40, 848.97, 869.04, 880.62, 893.97	-40	-102.4	> 50	38.0
137.70	824.04, 836.40, 848.97, 869.04, 880.62, 893.97	-40	-109.1	> 50	38.0
321.30	824.04, 836.40, 848.97, 869.04, 880.62, 893.97	-40	-116.1	> 50	38.0
505.80	824.04, 836.40, 848.97, 869.04, 880.62, 893.97	-40	-111.1	> 50	38.0
766.90	824.04, 836.40, 848.97, 869.04, 880.62, 893.97	-40	-107.5	> 50	38.0
781.54	824.04, 836.40, 848.97, 869.04, 880.62, 893.97	-40	-109.6	> 50	38.0
786.88	824.04, 836.40, 848.97, 869.04, 880.62, 893.97	-40	-108.9	> 50	38.0
796.05	824.04, 836.40, 848.97, 869.04, 880.62, 893.97	-40	-105.7	> 50	38.0
799.36	824.04, 836.40, 848.97, 869.04, 880.62, 893.97	-40	-106.8	> 50	38.0
804.14	824.04, 836.40, 848.97, 869.04, 880.62, 893.97	-40	-105.1	> 50	38.0
823.65	824.04, 836.40, 848.97, 869.04, 880.62, 893.97	-40	-107.9	> 50	38.0
855.55	824.04, 836.40, 848.97, 869.04, 880.62, 893.97	-40	-104.2	> 50	38.0
857.46	824.04, 836.40, 848.97, 869.04, 880.62, 893.97	-40	-106.2	> 50	38.0
858.91	824.04, 836.40, 848.97, 869.04, 880.62, 893.97	-40	-106.0	> 50	38.0
895.74	824.04, 836.40, 848.97, 869.04, 880.62, 893.97	-55	-108.3	> 50	38.0
897.97	824.04, 836.40, 848.97, 869.04, 880.62, 893.97	-40	-108.5	> 50	38.0
905.55	824.04, 836.40, 848.97, 869.04, 880.62, 893.97	-40	-107.0	> 50	38.0
907.32	824.04, 836.40, 848.97, 869.04, 880.62, 893.97	-40	-107.8	> 50	38.0
917.13	824.04, 836.40, 848.97, 869.04, 880.62, 893.97	-40	-107.1	> 50	38.0
918.90	824.04, 836.40, 848.97, 869.04, 880.62, 893.97	-40	-107.9	> 50	38.0

ULTRATECH GROUP OF LABS

3000 Bristol Circle, Oakville, Ontario, Canada L6H 6G4
Tel. #: 905-829-1570, Fax. #: 905-829-8050, Email: vic@ultratech-labs.com, Website: <http://www.ultratech-labs.com>

File #: ICOM-196F15B121
February 18, 2009

All test results contained in this engineering test report are traceable to National Institute of Standards and Technology (NIST)

956.80	824.04, 836.40, 848.97, 869.04, 880.62, 893.97	-40	-105.3	> 50	38.0
961.17	824.04, 836.40, 848.97, 869.04, 880.62, 893.97	-40	-104.6	> 50	38.0
965.80	824.04, 836.40, 848.97, 869.04, 880.62, 893.97	-40	-103.7	> 50	38.0
966.51	824.04, 836.40, 848.97, 869.04, 880.62, 893.97	-40	-103.4	> 50	38.0
971.50	824.04, 836.40, 848.97, 869.04, 880.62, 893.97	-40	-104.1	> 50	38.0
929.29	824.04, 836.40, 848.97, 869.04, 880.62, 893.97	-45	-103.9	> 50	38.0

ULTRATECH GROUP OF LABS

3000 Bristol Circle, Oakville, Ontario, Canada L6H 6G4
Tel. #: 905-829-1570, Fax. #: 905-829-8050, Email: vic@ultratech-labs.com, Website: <http://www.ultratech-labs.com>

File #: ICOM-196F15B121

February 18, 2009

All test results contained in this engineering test report are traceable to National Institute of Standards and Technology (NIST)

5.8.3.4. WFM mode

EUT's Scanning Frequency Band (MHz)	Cellular Transmitter Test Frequencies (MHz)	RF Input Signal Level @ Cellular Frequencies for 12 dB SINAD (dBm)	Reference Sensitivity (dBm)	Rejection Ratio (dB)	Maximum Rejection Ratio Limit (dB)
46.00	824.04, 836.40, 848.97, 869.04, 880.62, 893.97	-40	-103.7	> 50	38.0
61.25	824.04, 836.40, 848.97, 869.04, 880.62, 893.97	-40	-98.5	> 50	38.0
91.85	824.04, 836.40, 848.97, 869.04, 880.62, 893.97	-40	-100.6	> 50	38.0
107.20	824.04, 836.40, 848.97, 869.04, 880.62, 893.97	-40	-102.4	> 50	38.0
742.15	824.04, 836.40, 848.97, 869.04, 880.62, 893.97	-40	-98.9	> 50	38.0
747.15	824.04, 836.40, 848.97, 869.04, 880.62, 893.97	-40	-98.2	> 50	38.0
752.15	824.04, 836.40, 848.97, 869.04, 880.62, 893.97	-40	-97.2	> 50	38.0
755.75	824.04, 836.40, 848.97, 869.04, 880.62, 893.97	-40	-97.3	> 50	38.0
757.10	824.04, 836.40, 848.97, 869.04, 880.62, 893.97	-40	-98.5	> 50	38.0
759.25	824.04, 836.40, 848.97, 869.04, 880.62, 893.97	-40	-98.4	> 50	38.0
762.15	824.04, 836.40, 848.97, 869.04, 880.62, 893.97	-40	-99.8	> 50	38.0
762.85	824.04, 836.40, 848.97, 869.04, 880.62, 893.97	-40	-99.1	> 50	38.0
766.40	824.04, 836.40, 848.97, 869.04, 880.62, 893.97	-40	-98.7	> 50	38.0
786.60	824.04, 836.40, 848.97, 869.04, 880.62, 893.97	-40	-99.8	> 50	38.0
789.55	824.04, 836.40, 848.97, 869.04, 880.62, 893.97	-40	-99.2	> 50	38.0
793.15	824.04, 836.40, 848.97, 869.04, 880.62, 893.97	-40	-98.7	> 50	38.0
796.70	824.04, 836.40, 848.97, 869.04, 880.62, 893.97	-40	-97.6	> 50	38.0
799.00	824.04, 836.40, 848.97, 869.04, 880.62, 893.97	-40	-97.8	> 50	38.0
800.25	824.04, 836.40, 848.97, 869.04, 880.62, 893.97	-40	-96.3	> 50	38.0
804.85	824.04, 836.40, 848.97, 869.04, 880.62, 893.97	-40	-94.7	> 50	38.0
808.75	824.04, 836.40, 848.97, 869.04, 880.62, 893.97	-40	-95.6	> 50	38.0

ULTRATECH GROUP OF LABS

3000 Bristol Circle, Oakville, Ontario, Canada L6H 6G4
Tel. #: 905-829-1570, Fax. #: 905-829-8050, Email: vic@ultratech-labs.com, Website: <http://www.ultratech-labs.com>

File #: ICOM-196F15B121
February 18, 2009

All test results contained in this engineering test report are traceable to National Institute of Standards and Technology (NIST)

EXHIBIT 6. Test Equipments List

Test Instruments	Manufacturer	Model No.	Serial No.	Operating Range
Attenuator	Weinschel	46-20-34	BM1347	DC – 18 GHz
Attenuator	Weinschel	46-30-34	BM5354	DC – 18 GHz
BiConiLog Antenna	Emco	3142	10005	0.03 – 2 GHz
BiConiLog Antenna	ETS-Lindgren	3142B	1575	26 MHz – 2 GHz
Communication test set	Hewlett Packard	8920B	US39064699	AF SG DC – 20 kHz
Combiner	Weinschel	1515	93459	DC – 10 GHz
Distortion analyzer	Hewlett-Packard	8903E	3514A01460	20-100K Hz
EMC Analyzer	Hewlett Packard	8593EM	...	9kHz – 22 GHz
FFT (audio) EMI Receiver	Advantest	R9211E	82020336	10 mHz – 100 kHz, 1 MHz Input Impedance
High Pass Filter	Mini-Circuits	SHP-300	10427	Cut of 230 MHz
Horn Antenna	Emco	3155	9701-5061	1 – 18 GHz
Horn Antenna	Emco	3155	9911-5955	1 – 18 GHz
Infinium Oscilloscope	Hewlett Packard	54810A	US38380192	500 MHz, 1 GSa/s
L.I.S.N.	EMCO	3810/2	2209	9 kHz – 200 MHz 50 Ohms / 50 µH
12'x16'x12' RF Shielded Chamber	RF Shielding
Microwave Frequency Counter	EIP	545A	2683	10 Hz – 18 GHz
Modulation Analyzer	Hewlett Packard	8910B	3226A04606	150 kHz – 1300 MHz
Power Divider	Mini-Circuits	15542	105	1 MHz – 1 GHz
Power Meter	Hewlett Packard	437B	3.13E+09	10 kHz – 50 GHz
Power Sensor	Hewlett Packard	8481A	1150A15143	9 kHz – 26.5 GHz
RF Amplifier	Com-Power	PA-103		1 MHz – 1 GHz
RF Amplifier	Hewlett Packard	84498	3008A00769	1 – 26.5 GHz
Signal Generator	Hewlett Packard	83752B	3610A00457	0.01- 20 GHz
Signal Generator	IFR Systems Inc.	2025	20304/137	9 kHz – 2.51 GHz

ULTRATECH GROUP OF LABS

3000 Bristol Circle, Oakville, Ontario, Canada L6H 6G4
Tel. #: 905-829-1570, Fax. #: 905-829-8050, Email: vic@ultratech-labs.com, Website: <http://www.ultratech-labs.com>

File #: ICOM-196F15B121

February 18, 2009

All test results contained in this engineering test report are traceable to National Institute of Standards and Technology (NIST)

Spectrum Analyzer	Rohde & Schwarz	FSEK20/B4/B21	834157/005	9 kHz – 40 GHz
Spectrum Analyzer	Rohde & Schwarz	FSEK30	100077	20 Hz – 40 GHz
Spectrum Analyzer	Advantest	R3271	15050203	100 Hz – 26.5 GHz
Spectrum Analyzer / EMI Receiver	Hewlett Packard	8593EM	3710A00223	9 kHz – 6.5 GHz Built-in amplifier 30dB
Temperature & Humidity Chamber	Tenney	T5	9723B	-40 °C – +80 °C range
Transient Limiter	Hewlett Packard	11947A	3107A01998	9 kHz – 200 MHz 10 dB attenuation

ULTRATECH GROUP OF LABS

3000 Bristol Circle, Oakville, Ontario, Canada L6H 6G4
Tel. #: 905-829-1570, Fax. #: 905-829-8050, Email: vic@ultratech-labs.com, Website: <http://www.ultratech-labs.com>

File #: ICOM-196F15B121

February 18, 2009

All test results contained in this engineering test report are traceable to National Institute of Standards and Technology (NIST)

EXHIBIT 7. MEASUREMENT UNCERTAINTY

The measurement uncertainties stated were calculated in accordance with the requirements of NIST Technical Note 1297 and LAB 34

7.1. LINE CONDUCTED EMISSION MEASUREMENT UNCERTAINTY

CONTRIBUTION (Line Conducted)	PROBABILITY DISTRIBUTION	UNCERTAINTY (dB)	
		9-150 kHz	0.15-30 MHz
EMI Receiver specification	Rectangular	± 1.5	± 1.5
LISN coupling specification	Rectangular	± 1.5	± 1.5
Cable and Input Transient Limiter calibration	Normal (k=2)	± 0.3	± 0.5
Mismatch: Receiver VRC $\Gamma_1 = 0.03$ LISN VRC $\Gamma_R = 0.8(9 \text{ kHz}) 0.2 (30 \text{ MHz})$ Uncertainty limits $20\text{Log}(1+\Gamma_1\Gamma_R)$	U-Shaped	± 0.2	± 0.3
System repeatability	Std. deviation	± 0.2	± 0.05
Repeatability of EUT	--	--	--
Combined standard uncertainty	Normal	± 1.25	± 1.30
Expanded uncertainty U	Normal (k=2)	± 2.50	± 2.60

Sample Calculation for Measurement Accuracy in 150 kHz to 30 MHz Band:

$$u_c(y) = \sqrt{\sum_{i=1}^m u_i^2(y)} = \pm \sqrt{(1.5^2 + 1.5^2)/3 + (0.5/2)^2 + (0.05/2)^2 + 0.35^2} = \pm 1.30 \text{ dB}$$

$$U = 2u_c(y) = \pm 2.6 \text{ dB}$$

7.2. RADIATED EMISSION MEASUREMENT UNCERTAINTY

CONTRIBUTION (Radiated Emissions)	PROBABILITY DISTRIBUTION	UNCERTAINTY (\pm dB)	
		3 m	10 m
Antenna Factor Calibration	Normal (k=2)	± 1.0	± 1.0
Cable Loss Calibration	Normal (k=2)	± 0.3	± 0.5
EMI Receiver specification	Rectangular	± 1.5	± 1.5
Antenna Directivity	Rectangular	+0.5	+0.5
Antenna factor variation with height	Rectangular	± 2.0	± 0.5
Antenna phase center variation	Rectangular	0.0	± 0.2
Antenna factor frequency interpolation	Rectangular	± 0.25	± 0.25
Measurement distance variation	Rectangular	± 0.6	± 0.4
Site imperfections	Rectangular	± 2.0	± 2.0
Mismatch: Receiver VRC $\Gamma_1 = 0.2$ Antenna VRC $\Gamma_R = 0.67(\text{Bi}) 0.3 (\text{Lp})$ Uncertainty limits $20\text{Log}(1 \pm \Gamma_1 \Gamma_R)$	U-Shaped	+1.1 -1.25	± 0.5
System repeatability	Std. Deviation	± 0.5	± 0.5
Repeatability of EUT		-	-
Combined standard uncertainty	Normal	+2.19 / -2.21	+1.74 / -1.72
Expanded uncertainty U	Normal (k=2)	+4.38 / -4.42	+3.48 / -3.44

Calculation for maximum uncertainty when 3m biconical antenna including a factor of k = 2 is used:

$$U = 2u_c(y) = 2x(+2.19) = +4.38 \text{ dB} \quad \text{And} \quad U = 2u_c(y) = 2x(-2.21) = -4.42 \text{ Db}$$