

ENGINEERING TEST REPORT

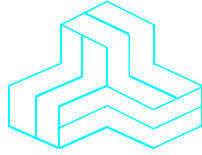

VHF Air Band Transceiver
Model: IC-A220
FCC ID: AFJ297410

Applicant:

ICOM Incorporated
1-1-32, Kamiminami, Hirano-ku
Osaka, Japan, 547-0003

Tested in Accordance with

Federal Communications Commission (FCC)
47 CFR, Parts 2 and 87 (Subpart D) – Aviation Services

UltraTech's File No.: 16ICOM426_FCC87

This Test report is Issued under the Authority of
Tri M. Luu
Vice President of Engineering
UltraTech Group of Labs

Date: May 17, 2016

Report Prepared by: Dan Huynh

Tested by: Wei Wu

Issued Date: May 17, 2016

Test Dates: April 21-22 & May 3, 2016

- *The results in this Test Report apply only to the sample(s) tested, and the sample tested is randomly selected.*
- *This report must not be used by the client to claim product endorsement by NVLAP or any agency of the US Government.*

UltraTech

3000 Bristol Circle, Oakville, Ontario, Canada, L6H 6G4
Tel.: (905) 829-1570 Fax.: (905) 829-8050
Website: www.ultratech-labs.com, Email: vic@ultratech-labs.com, Email: tri@ultratech-labs.com



91038



1309



46390-2049



NVLAP LAB
CODE 200093-0



AT-1945



SL2-IN-E-
1119R



CA2049



TL363_B



TPTDP
DA1300

TABLE OF CONTENTS

EXHIBIT 1. INTRODUCTION..... 2

1.1. SCOPE 2

1.2. RELATED SUBMITTAL(S)/GRANT(S) 2

1.3. NORMATIVE REFERENCES 2

EXHIBIT 2. PERFORMANCE ASSESSMENT..... 3

2.1. CLIENT INFORMATION 3

2.2. EQUIPMENT UNDER TEST (EUT) INFORMATION 3

2.3. EUT'S TECHNICAL SPECIFICATIONS..... 4

2.4. LIST OF EUT'S PORTS..... 4

EXHIBIT 3. EUT OPERATING CONDITION AND CONFIGURATIONS DURING TESTS 5

3.1. CLIMATE TEST CONDITIONS 5

3.2. OPERATIONAL TEST CONDITIONS & ARRANGEMENT FOR TEST SIGNALS 5

EXHIBIT 4. SUMMARY OF TEST RESULTS 6

4.1. LOCATION OF TESTS 6

4.2. APPLICABILITY & SUMMARY OF EMISSION TEST RESULTS 6

4.3. MODIFICATIONS INCORPORATED IN THE EUT FOR COMPLIANCE PURPOSES..... 6

4.4. DEVIATION OF STANDARD TEST PROCEDURES..... 6

EXHIBIT 5. TEST DATA 7

5.1. RF POWER OUTPUT [§§ 2.1046 & 87.131]..... 7

5.2. FIELD STRENGTH OF SPURIOUS EMISSIONS [§§ 2.1053, 87.139] 9

5.3. FREQUEECNY STABILITY [§§ 2.1055 & 87.133] 11

EXHIBIT 6. TEST EQUIPMENT LIST 13

EXHIBIT 7. MEASUREMENT UNCERTAINTY 14

7.1. RADIATED EMISSION MEASUREMENT UNCERTAINTY 14

EXHIBIT 1. INTRODUCTION

1.1. SCOPE

Reference:	FCC Parts 2 and 87
Title:	Code of Federal Regulations (CFR), Title 47 Telecommunication – Parts 2 & 87
Purpose of Test:	To obtain FCC Equipment Authorization for Radio operating under Part 87. Class II Permissive Change on electric parts: MAIN-C unit, FRONT-C unit, PA-C unit, D-CONNECT-A unit and VOLUME-B unit are replaced.
Test Procedures:	ANSI C63.26

1.2. RELATED SUBMITTAL(S)/GRANT(S)

None

1.3. NORMATIVE REFERENCES

Publication	Year	Title
FCC CFR Parts 0-19, 80-End	2016	Code of Federal Regulations – Telecommunication
ANSI C63.4	2014	American National Standard for Methods of Measurement of Radio-Noise Emissions from Low-Voltage Electrical and Electronic Equipment in the Range of 9 kHz to 40 GHz
ANSI C63.26	2015	American National Standard for Compliance Testing of Transmitters Used in Licensed Radio Services
TIA/EIA 603, Edition D	2010	Land Mobile FM or PM Communications Equipment Measurement and Performance Standards

EXHIBIT 2. PERFORMANCE ASSESSMENT

2.1. CLIENT INFORMATION

APPLICANT	
Name:	Icom Incorporated
Address:	1-1-32, Kamiminami Hirano-ku, Osaka Japan, 547-0003
Contact Person:	Mr. Hideji Fujishima Phone #: +81 6 6793 5302 Fax #: +81 6 6793 0013 Email Address: world_support@icom.co.jp

MANUFACTURER	
Name:	Icom Incorporated
Address:	1-1-32, Kamiminami Hirano-ku, Osaka Japan, 547-0003
Contact Person:	Mr. Hideji Fujishima Phone #: +81 6 6793 5302 Fax #: +81 6 6793 0013 Email Address: world_support@icom.co.jp

2.2. EQUIPMENT UNDER TEST (EUT) INFORMATION

The following information (with the exception of the Date of Receipt) has been supplied by the applicant.

Brand Name:	ICOM Incorporated
Product Name:	VHF Air Band Transceiver
Model Name or Number:	IC-A220
Serial Number:	0000024
External Power Supply:	DC 13.8V / 27.5V
Transmitting/Receiving Antenna Type:	Non-integral
Type of Equipment:	Non-broadcast Radio Communication Equipment
Primary User Functions of EUT:	VHF air band transceiver for voice communication in Occupational environment.

2.3. EUT’S TECHNICAL SPECIFICATIONS

TRANSMITTER	
Equipment Type:	Mobile or Base
Intended Operating Environment:	Commercial, industrial or business environment
Power Supply Requirement:	DC 13.8V / 27.5V
RF Output Power Rating:	8 W (CW) Conducted
Operating Frequency Range:	118.00-136.9917 MHz
RF Output Impedance:	50 Ω
Channel Spacing:	25.0 kHz, 8.33 kHz
Emission Designation*:	6K00A3E, 5K60A3E
Antenna Connector Type:	ICOM Unique Type

* For an average case of commercial telephony, the Necessary Bandwidth is calculated as follows:

Calculation of Necessary Bandwidth for Telephony (Commercial Quality)

Telephony, double-sideband (single channel):

$$B_n = 2M$$

Where: B_n = Necessary bandwidth in hertz
 M = Maximum modulation frequency in hertz

$$M = 3000\text{Hz}$$

$$B_n = 2(3000) = 6000 \text{ Hz} = 6.00 \text{ KHz}$$

2.4. LIST OF EUT’S PORTS

Port Number	EUT’s Port Description	Number of Identical Ports	Connector Type	Cable Type (Shielded/Non-shielded)
1	Antenna	1	ICOM Unique	Shielded
2	DC, Speaker, Microphone Headphone & Data Jack	1	DB-25	Non-Shielded

EXHIBIT 3. EUT OPERATING CONDITION AND CONFIGURATIONS DURING TESTS

3.1. CLIMATE TEST CONDITIONS

The climate conditions of the test environment are as follows:

Temperature:	21°C - 24°C
Humidity:	30% - 57%
Pressure:	102 kPa
Power input source:	13.8V & 27.5V DC Power Supply

3.2. OPERATIONAL TEST CONDITIONS & ARRANGEMENT FOR TEST SIGNALS

Operating Modes:	The transmitter was operated in a continuous transmission mode with the carrier modulated as specified in the Test Data.
Special Test Software:	N/A
Special Hardware Used:	Test jig was provided by the manufacturer.
Transmitter Test Antenna:	The EUT is tested with the transmitter antenna port terminated to a 50 Ω Load.

Transmitter Test Signals	
Frequency Band(s):	118.00-136.9917 MHz
Test Frequency(ies): (Near lowest, near middle & near highest frequencies in the frequency range of operation.)	118.025, 127.500 and 136.975 MHz (25 kHz Ch Spacing)
Transmitter Wanted Output Test Signals:	
▪ RF Power Output (measured maximum output power):	8 W
▪ Normal Test Modulation:	AM or 2500 Hz tone at an input level 16 dB greater than that necessary to produce 50 percent modulation
▪ Modulating signal source:	External

EXHIBIT 4. SUMMARY OF TEST RESULTS

4.1. LOCATION OF TESTS

All of the measurements described in this report were performed at Ultratech Group of Labs located in the city of Oakville, Province of Ontario, Canada.

Radiated Emissions were performed at the Ultratech's 3-10 TDK Semi-Anechoic Chamber situated in the Town of Oakville, province of Ontario. This test site has been calibrated in accordance with ANSI C63.4, and found to be in compliance with the requirements of Sec.2.948 of the FCC Rules. The descriptions and site measurement data of the Oakville 3-10 TDK Semi-Anechoic Chamber has been filed with FCC office (FCC File No.: 91038) and Industry Canada office (Industry Canada File No.: 2049A-3). Expiry Date: 2017-04-04.

4.2. APPLICABILITY & SUMMARY OF EMISSION TEST RESULTS

FCC Section(s)	Test Requirements	Applicability (Yes/No)
2.1046 & 87.131	RF Power Output	Yes
1.1307, 1.1310, 2.1091 & 2.1093	RF Exposure Limit	N/A, See Note 1
2.1047(a) & 87.141(f)	Modulation Characteristics - Audio Frequency Response of Low-pass Filter	N/A, See Note 1
2.1047(b) & 87.141	Modulation Characteristics - Modulation Limiting	N/A, See Note 1
2.1049, 87.135, 87.137 & 87.139	Occupied Bandwidth and Emission Limitations	N/A, See Note 1
2.1051, 2.1057 & 87.139,	Spurious Emissions at Antenna Terminal	N/A, See Note 1
2.1053, 2.1057 & 87.139	Field Strength of Spurious Emissions	Yes
2.1055 & 87.133	Frequency Stability	Yes

Note 1: Not applicable for this Class II Permissive Change filing.

4.3. MODIFICATIONS INCORPORATED IN THE EUT FOR COMPLIANCE PURPOSES

None

4.4. DEVIATION OF STANDARD TEST PROCEDURES

None

ULTRATECH GROUP OF LABS

3000 Bristol Circle, Oakville, Ontario, Canada L6H 6G4
Tel. #: 905-829-1570, Fax. #: 905-829-8050, Email: vic@ultratech-labs.com, Website: <http://www.ultratech-labs.com>

File #: 16ICOM426_FCC87
May 17, 2016

All test results contained in this engineering test report are traceable to National Institute of Standards and Technology (NIST)

EXHIBIT 5. TEST DATA

5.1. RF POWER OUTPUT [§§ 2.1046 & 87.131]

5.1.1. Limits

The following table lists authorized emissions and maximum power. Power must be determined by direct measurement.

Class of station	Frequency band/ frequency	Authorized emission(s) ²	Maximum power ¹
Aeronautical advisory	VHF	A3E	10 watts ³
Aeronautical multicom	VHF	A3E	10 watts
Aeronautical search and rescue	VHF	A3E	10 watts
Aeronautical utility mobile	VHF	A3E	10 watts

Notes:

- (1) The power is measured at the transmitter output terminals and the type of power is determined according to the emission designator as follows:
 - (i) Mean power (pY) for amplitude modulated emissions and transmitting both sidebands using unmodulated full carrier.
 - (ii) Peak envelope power (pX) for all emission designators other than those referred to in paragraph (i) of this note.
- (2) Excludes automatic link establishment.
- (3) Power is limited to 0.5 watt, but may not exceed 2 watts when station is used in an automatic unattended mode.

5.1.2. Method of Measurements

ANSI C63.26-2015, Section 5.2

5.1.3. Test Arrangement

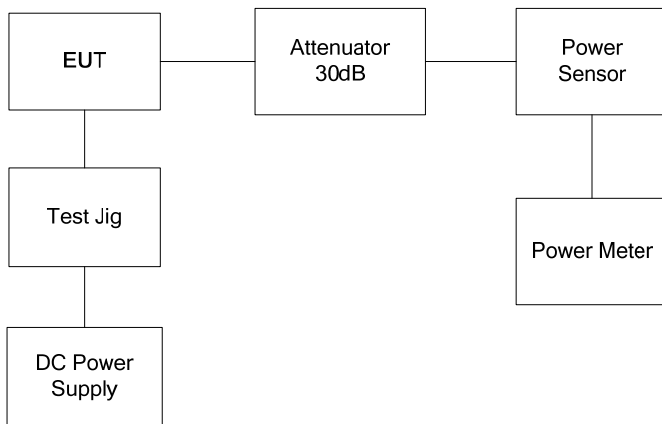

5.1.4. Test Data

(a) 13.8 V DC Power

Channel	Frequency (MHz)	Channel Spacing (kHz)	Power Rating		Measured Power	
			(W)	(dBm)	(dBm)	(W)
1	118.025	25	8	39.03	38.97	7.89
2	127.500	25	8	39.03	38.92	7.80
3	136.975	25	8	39.03	38.96	7.87

(b) 27.5 V DC Power

Channel	Frequency (MHz)	Channel Spacing (kHz)	Power Rating		Measured Power	
			(W)	(dBm)	(dBm)	(W)
1	118.025	25	8	39.03	39.04	8.02
2	127.500	25	8	39.03	38.99	7.93
3	136.975	25	8	39.03	39.01	7.96

5.2. FIELD STRENGTH OF SPURIOUS EMISSIONS [§§ 2.1053, 87.139]

5.2.1. Limit(s)

§ 87.139(a)(3) - When the frequency is removed from the assigned frequency by more than 250 percent of the authorized bandwidth the attenuation for aircraft station transmitters must be at least 40 dB; and the attenuation for aeronautical station transmitters must be at least $43 + 10 \log_{10} \text{ pY dB}$.

5.2.2. Method of Measurements

ANSI C63.26-2015, Section 5.5.

5.2.3. Test Arrangement

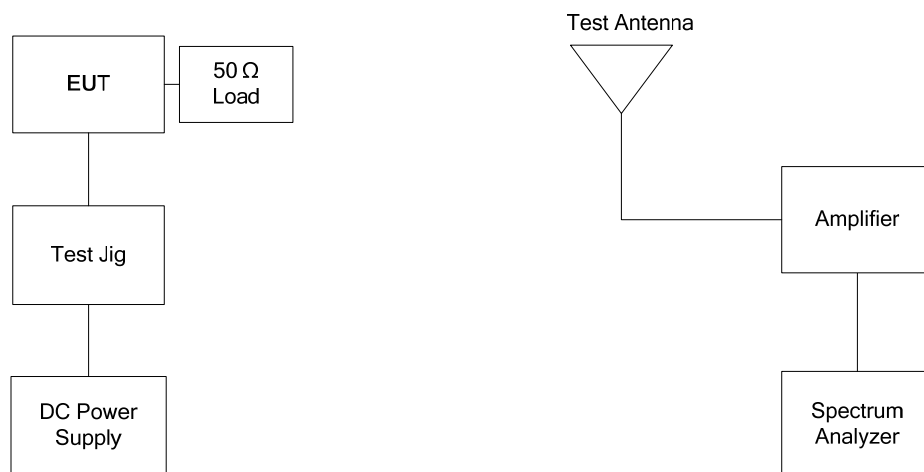

5.2.4. Test Data

Remark(s):

- The emissions were scanned from 30 MHz to 6 GHz; all spurious emissions that are in excess of 20dB below the specified limit shall be recorded.
- There was no difference in spurious/harmonic emissions on the pre-scans for different channel spacing and input voltage levels. Therefore, the RF spurious/harmonic emissions in this section would be performed for 25 KHz channel spacing with 27.5 VDC level and limit of $43 + 10 \log_{10} pY$ dB applied for worst case.

Carrier Frequency:		118.025 MHz				
Power:		8.02 W				
Limit:		-13 dBm				
Frequency (MHz)	E-Field (dBµV/m)	EMI Detector (Peak/QP)	Antenna Polarization (H/V)	ERP (dBm)	Limit (dBm)	Margin (dB)
30 - 6000	*	Peak	H/V	*	-13	*

* All harmonics and spurious emissions are more than 20 dB below the specified attenuation limit.

Carrier Frequency:		127.500 MHz				
Power:		7.93 W				
Limit:		-13 dBm				
Frequency (MHz)	E-Field (dBµV/m)	EMI Detector (Peak/QP)	Antenna Polarization (H/V)	ERP (dBm)	Limit (dBm)	Margin (dB)
30 - 6000	*	Peak	H/V	*	-13	*

* All harmonics and spurious emissions are more than 20 dB below the specified attenuation limit.

Carrier Frequency:		136.975 MHz				
Power:		7.96 W				
Limit:		-13 dBm				
Frequency (MHz)	E-Field (dBµV/m)	EMI Detector (Peak/QP)	Antenna Polarization (H/V)	ERP (dBm)	Limit (dBm)	Margin (dB)
30 - 6000	*	Peak	H/V	*	-13	*

* All harmonics and spurious emissions are more than 20 dB below the specified attenuation limit.

5.3. FREQUENCY STABILITY [§§ 2.1055 & 87.133]

5.3.1. Limits

§ 87.133 The carrier frequency of each station must be maintained within the tolerance in the following table:

Frequency band (lower limit exclusive, upper limit inclusive), and categories of station	Tolerance (ppm)
(5) Band - 108 to 137 MHz: Aircraft and other mobile stations in the Aviation Services.	*30

* For emissions G1D and G7D, the tolerance is 5 parts per 10⁶.

5.3.2. Method of Measurements

ANSI C63.26-2015, Section 5.6

5.3.3. Test Arrangement

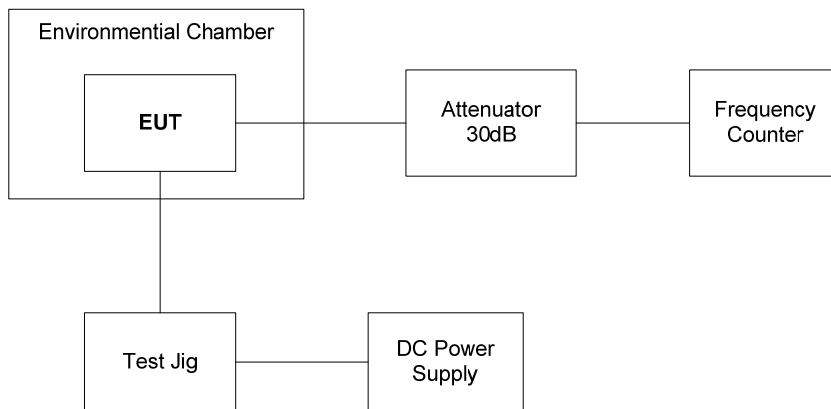

5.3.4. Test Data

Center Frequency:		118.0 MHz	
Full Power Level:		8 W	
Frequency Tolerance Limit (Worst Case):		30 ppm or 3540 Hz (Manufacturer's rating: ± 5 ppm)	
Max. Frequency Tolerance Measured:		-52 Hz or 0.44 ppm	
Input Voltage Rating:		13.8 / 27.5 V DC	
Ambient Temperature (°C)	Frequency Drift (Hz)		
	Supply Voltage (Nominal) 27.5 VDC	Supply Voltage (Lowest, 85% of 13.8V) 11.73 VDC	Supply Voltage (115% of Nominal) 31.625 VDC
-30	20	--	--
-20	10	--	--
-10	10	--	--
0	28	--	--
+10	34	--	--
+20	19	-18	-20
+30	-51	--	--
+40	-52	--	--
+50	-12	--	--
+60	-24	--	--

EXHIBIT 6. TEST EQUIPMENT LIST

Test Instruments	Manufacturer	Model No.	Serial No.	Operating Range	Cal. Due Date
Spectrum Analyzer	R/S	FSU	100398	20 Hz – 26.5 GHz	14 Sep 2017
Attenuator (40dB)	Aeroflex/Weinschel	53-40-34	MN917	DC-1 GHz	Cal. on use.
High Pass Filter	Mini Circuit	SHP 200		Cut off 200 MHz	Cal. on use.
Power Meter	Hewlett Packard	438A	2016A07747	100K--50G sensor dependent	29 Sep 2016
Power Sensor	Hewlett Packard	8481A	2237A33409	100KHz-18GHZ	29 Sep 2016
Environmental Chamber	Envirotronics	SSH32C	11994847-S-11059	-60 to 177 °C	02 Jun 2016
Power supply	Tenma	72-7295	490300297	1-40V DC 5A	Cal. on use.
RF Communication Test Set	Hewlett Packard	8920B	US39064699	30MHz-1GHz	30 Jan 2017
Attenuator	Aeroflex/Weinschel	23-20-34	BH7876	DC-18 GHz	Cal. on use.
Antenna	ETS	93148	1101	200-2000 MHz	14 Jul 2016
Biconical Antenna	ETS	3110B	3379	20-200MHz	11 Sep 2016
Preamplifier	Com-power	PA-103A	161243	10-1000MHz	10 Jun 2016
Horn antenna	EMCO	3117	19425	1-18GHz	17 Jul 2017
Preamplifier	Com-power	PA-118A	551016	500MHz-18GHz	06 Jan 2017

ULTRATECH GROUP OF LABS

3000 Bristol Circle, Oakville, Ontario, Canada L6H 6G4
Tel. #: 905-829-1570, Fax. #: 905-829-8050, Email: vic@ultratech-labs.com, Website: <http://www.ultratech-labs.com>

File #: 16ICOM426_FCC87
May 17, 2016

All test results contained in this engineering test report are traceable to National Institute of Standards and Technology (NIST)

EXHIBIT 7. MEASUREMENT UNCERTAINTY

The measurement uncertainties stated were calculated in accordance with the requirements of CISPR 16-4-2 @ IEC:2003 and JCGM 100:2008 (GUM 1995) – Guide to the Expression of Uncertainty in Measurement.

7.1. RADIATED EMISSION MEASUREMENT UNCERTAINTY

	Radiated Emission Measurement Uncertainty @ 3m, Horizontal (30-1000 MHz):	Measured	Limit
u_c	Combined standard uncertainty: $u_c(y) = \sqrt{\sum_{i=1}^m u_i^2(y)}$	± 2.39	± 2.6
U	Expanded uncertainty U: $U = 2u_c(y)$	± 4.79	± 5.2

	Radiated Emission Measurement Uncertainty @ 3m, Vertical (30-1000 MHz):	Measured	Limit
u_c	Combined standard uncertainty: $u_c(y) = \sqrt{\sum_{i=1}^m u_i^2(y)}$	± 2.39	± 2.6
U	Expanded uncertainty U: $U = 2u_c(y)$	± 4.78	± 5.2

	Radiated Emission Measurement Uncertainty @ 3 m, Horizontal & Vertical (1 – 18 GHz):	Measured	Limit
u_c	Combined standard uncertainty: $u_c(y) = \sqrt{\sum_{i=1}^m u_i^2(y)}$	± 1.87	Under consideration
U	Expanded uncertainty U: $U = 2u_c(y)$	± 3.75	Under consideration