

ENGINEERING TEST REPORT

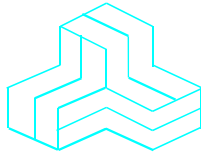

UHF Transceivers
Model No.: IC-F4031S
FCC ID: AFJ292701
IC: 202D-292701

Tested For
ICOM Incorporated
1-1-32, Kamiminami, Hirano-ku
Osaka,
Japan, 547-0003

In accordance with
**SAR (Specific Absorption Rate) Requirements using guidelines established in
IEEE C95.1-1992, FCC OET Bulletin 65 (Supplement C) and Industry Canada RSS-102 (Issue 4)**

UltraTech's File No.: ICOM-286Q-SAR

This Test report is Issued under the Authority of
Tri M. Luu, Professional Engineer,
Vice President of Engineering
UltraTech Group of Labs

Date: February 1, 2012

Report Prepared by:
Steven Lu
Issued Date:
February 1, 2012

Tested by:
Steven Lu
Test Dates:
December 12, 2011~ Jan. 4, 2012

The results in this Test Report apply only to the sample(s) tested, which has been randomly selected.

UltraTech Group of Labs

3000 Bristol Circle, Oakville, Ontario, Canada, L6H 6G4
Tel.: (905) 829-1570 Fax.: (905) 829-8050

Website: www.ultratech-labs.com, Email: vic@ultratech-labs.com, Email: tri@ultratech-labs.com

FCC

91038



1309



46390-2049



NVLAP Lab Code
200093-0



SL2-IN-E-1119R



Korea KCC-RRL
CA2049

TABLE OF CONTENTS

EXHIBIT 1. INTRODUCTION	1
1.1. SCOPE.....	1
1.2. REFERENCES	1
EXHIBIT 2. PERFORMANCE ASSESSMENT.....	2
2.1. CLIENT AND MANUFACTURER INFORMATION	2
2.2. DEVICE UNDER TEST (D.U.T.) DESCRIPTION	3
2.2.1. <i>Photograph of D.U.T.</i>	3
2.3. LIST OF D.U.T.'S ACCESSORIES:	4
2.3.1. <i>Li-ion Chargeable Battery (M/N: BP-232WP)</i>	4
2.3.2. <i>Belt-clip (M/N: MB-94)</i>	4
2.3.3. <i>Antennas: FA-SC57U (Red Ring)</i>	5
2.3.4. <i>Cut Antenna: FA-SC61UC (White Ring)</i>	5
2.3.5. <i>Speaker-microphone (M/N: HM-168LWP)</i>	6
2.3.6. <i>Speaker-microphone (M/N: HM-166LA)</i>	6
2.3.7. <i>Speaker-microphone (M/N: HM-159LA)</i>	7
2.3.8. <i>Speaker-microphone (MN: HM-158LA)</i>	7
2.3.9. <i>Speaker-microphone (MN: HM-153LA)</i>	8
2.4. SPECIAL CHANGES ON THE D.U.T.'S HARDWARE/SOFTWARE FOR TESTING PURPOSES.....	9
2.5. ANCILLARY EQUIPMENT	9
2.6. SPECIFIC OPERATING CONDITIONS	9
EXHIBIT 3. SUMMARY OF TEST RESULTS	10
3.1. LOCATION OF TESTS	10
3.2. APPLICABILITY & SUMMARY OF SAR RESULTS	10
3.2.1. <i>Added Speaker-microphone Accessories test*</i>	10
3.2.2. <i>Added Cut Antenna test*</i>	11
3.3. SUMMARY OF MEASUREMENT RESULTS	12
3.3.1. <i>Body Configuration Results for Added Speaker-microphones: Antennas (FA-SC57U)</i>	12
3.3.2. <i>Head Configuration Results for Cut Antenna (FA-SC61UC)</i>	13
3.3.3. <i>Body Configuration Results for Cut Antenna (FA-SC61UC)</i>	14
EXHIBIT 4. SAR SYSTEM CONFIGURATION	15
4.1. DASY5 SYSTEM OVERVIEW.....	15
4.1.1. <i>DASY5 System Specification</i>	15
4.1.2. <i>DASY5 SAR SYSTEM block diagram</i>	18
4.2. SAR TEST PHANTOMS	19
4.2.1. <i>SAM Twin Phantom</i>	19
4.2.2. <i>ELI 4.0 Phantom</i>	19
EXHIBIT 5. SAR DATA ACQUISITION METHODOLOGY	20
5.1. SAR MEASUREMENT PROCEDURE.....	20
5.1.1. <i>Interpolation, Extrapolation and Detection of Maxima</i>	22
5.1.2. <i>Averaging and Determination of Spatial Peak SAR</i>	23
5.1.3. <i>Evaluation Errors</i>	23
EXHIBIT 6. MEASUREMENTS, EXAMINATIONS & TEST DATA.....	25
6.1. TEST CONFIGURATIONS	25
6.2. GENERAL TEST SETUP	26

6.2.1.	<i>Equipment Configuration</i>	26
6.2.2.	<i>Exercising Equipment</i>	26
6.3.	PHOTOGRAPHS OF TISSUE DEPTH.....	27
6.4.	PHOTOGRAPHS OF D.U.T. POSITION.....	28
6.4.1.	<i>Body Configuration for Added Speaker-microphone: Antennas (FA-SC57U)</i>	28
6.4.2.	<i>Head Configuration for Added Cut Antenna (FA-SC61UC)</i>	29
6.4.3.	<i>Body Configuration for Added Cut Antenna (FA-SC61UC)</i>	33
6.5.	SAR MEASUREMENT DATA.....	37
6.5.1.	<i>Body Configuration Results for Added Speaker-microphones: Antenna (FA-SC57U)</i>	37
6.5.2.	<i>Head Configuration Result for Cut Antenna (FA-SC61UC)</i>	53
6.5.3.	<i>Body Configuration Result for Cut Antenna (FA-SC61UC)</i>	90
EXHIBIT 7.	SAR MEASUREMENT SYSTEM VERIFICATION	130
7.1.	STANDARD SOURCE.....	130
7.2.	STANDARD SOURCE INPUT POWER MEASUREMENT	131
7.3.	SYSTEM VALIDATION PROCEDURE.....	131
7.4.	VERIFICATION RESULTS	132
7.4.1.	<i>Reference SAR values at 450 MHz*</i>	132
7.4.2.	<i>Verification at 450 MHz</i>	133
EXHIBIT 8.	D.U.T. POWER MEASUREMENT	139
8.1.1.	<i>RF conducted output power measurement</i>	140
8.1.2.	<i>SAR drift measurement</i>	140
EXHIBIT 9.	TISSUE DIELECTRIC PARAMETER CALIBRATION	141
9.1.	SIMULATED TISSUE.....	141
9.2.	MEASUREMENT OF ELECTRICAL CHARACTERISTICS OF SIMULATED TISSUE	142
9.2.1.	<i>Equipment set-up</i>	142
9.2.2.	<i>Measurement procedure</i>	143
9.3.	SIMULATED TISSUE MEASUREMENT RESULTS	144
9.3.1.	<i>450 MHz Brain Tissue</i>	144
9.3.2.	<i>450 MHz Muscle Tissue</i>	144
EXHIBIT 10.	SAR MEASUREMENT UNCERTAINTY	145
10.1.	MEASUREMENT UNCERTAINTY EVALUATION FOR SAR TEST	145
EXHIBIT 11.	ADDITIONAL TEST INSTRUMENTS LIST	146
EXHIBIT 12.	PROBE CALIBRATION CERTIFICATE	146
EXHIBIT 13.	VALIDATION DIPOLE CALIBRATION CERTIFICATE	146

EXHIBIT 1. INTRODUCTION

1.1. SCOPE

Reference:	SAR (Specific Absorption Rate) Requirements IEEE C95.1-1992, FCC OET Bulletin 65 (Supplement C Edition 01-01) Industry Canada RSS-102 (Issue 4).
Title	Safety Levels with respect to human exposure to Radio Frequency Electromagnetic Fields Guideline for Evaluating the Environmental Effects of Radio Frequency Radiation
Purpose of Test:	To verify compliance with Federal regulated SAR requirements in Canada and the US.
Method of Measurements:	IEEE C95.1-1992, FCC OET Bulletin 65 (Supplement C Edition 01-01) and Industry Canada RSS-102 (Issue 4)
Device Category	Portable
Exposure Category	Occupational/Controlled

1.2. REFERENCES

The methods and procedures used for the measurements contained in this report are details in the following reference standards:

Publications	Year	Title
IEEE Std. 1528	2003	Draft Recommended practice for determining the Peak Spatial-Average Specific Absorption rate (SAR) in the Human Body Due to Wireless Communications Devices: Experimental Techniques.
Industry Canada RSS-102	2010	“Evaluation Procedure for Mobile and Portable Radio Transmitters with respect to Health Canada’s Safety Code 6 for Exposure of Humans to Radio Frequency Fields”
NCRP Report No.86	1986	“Biological Effects and Exposure Criteria for radio Frequency Electromagnetic Fields”
FCC OET Bulletin 65	2001	“Evaluating Compliance with FCC Guidelines for Human Exposure to radio Frequency Fields”
ANSI/IEEE C95.3	2002	“Recommended Practice for the Measurement of Potentially Hazardous Electromagnetic Fields - RF and Microwave”
ANSI/IEEE C95.1	2005	“Safety Levels with Respect to Human Exposure to Radio Frequency Electromagnetic Fields, 3kHz to 300GHz”
IEC 62209-2	2010	Human exposure to radio frequency fields from hand-held and body-mounted wireless communication devices – Human models, instrumentation, and procedures – Part 2: Procedure to determine the specific absorption rate (SAR) for wireless communication devices used in close proximity to the human body (frequency range of 30 MHz to 6 GHz)
Health Canada’s Safety Code 6	2009	Limits of Human Exposure to Radiofrequency Electromagnetic Energy in the Frequency Range from 3 kHz to 300 GHz

EXHIBIT 2. PERFORMANCE ASSESSMENT

2.1. CLIENT AND MANUFACTURER INFORMATION

APPLICANT:	
Name:	ICOM Incorporated
Address:	1-1-32, Kamiminami, Hirano-ku, Osaka Japan, 547-0003
Contact Person:	Mr. Takayuki Watanabe Phone #: +81-66-793-5302 Fax #: +81-66-793-0013 Email Address: export@icom.co.jp

MANUFACTURER:	
Name:	ICOM Incorporated
Address:	1-1-32, Kamiminami, Hirano-ku, Osaka Japan, 547-0003
Contact Person:	Mr. Takayuki Watanabe Phone #: +81-66-793-5302 Fax #: +81-66-793-0013 Email Address: export@icom.co.jp

ULTRATECH GROUP OF LABS

3000 Bristol Circle, Oakville, Ontario, Canada L6H 6G4

Tel. #: 905-829-1570, Fax #: 905-829-8050, Email: vic@ultratech-labs.com, Website: <http://www.ultratech-labs.com>

File #: ICOM-286Q-SAR

February 1, 2012

- All test results contained in this engineering test report are traceable to National Institute of Standards and Technology (NIST)

2.2. DEVICE UNDER TEST (D.U.T.) DESCRIPTION

The following is the information provided by the applicant.

Trade Name	ICOM Inc.
Type/Model Number	IC-F4031S
Type of Equipment	Licensed Non-Broadcast Transceiver
Serial Number	7200001
Transmitter Frequency Band	400 ~ 470 MHz
Rated RF Power	4 Watts conducted (High)
Modulation Employed	FM
Antenna	¼ Helical whip antenna (M/N: FA-SC57U, 430-470 MHz, -3.0dBi, red ring) ¼ Helical whip cut antenna (M/N: FA-SC61UC, 360-520 MHz, -1.3dBi, white ring)
Power Supply	Rechargeable Li-Ion battery pack (M/N: BP-232WP, 7.4 V, 2250mAh)
Primary User Functions of D.U.T.	UHF Transceivers

2.2.1. Photograph of D.U.T



< D.U.T.'s front and rear view without battery and antenna >

2.3. LIST OF D.U.T.'S ACCESSORIES:

2.3.1. Li-ion Chargeable Battery (M/N: BP-232WP)



< BP-265 Li-ion Battery >

2.3.2. Belt-clip (M/N: MB-94)



< MB-94 Belt-clip >

2.3.3. Antennas: FA-SC57U (Red Ring)



< FA-SC57U (Red Ring) >

2.3.4. Cut Antenna: FA-SC61UC (White Ring)

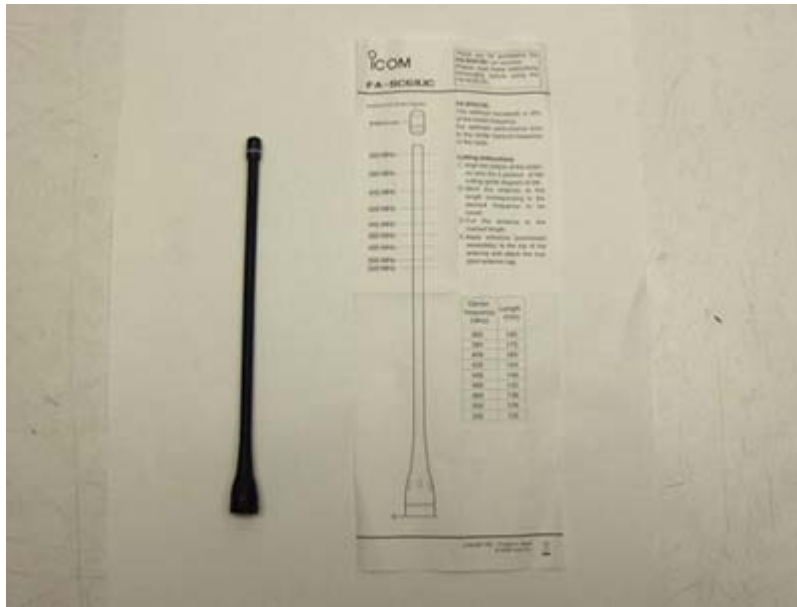

< FA-SC61UC cut antenna (White Ring) >

2.3.5. Speaker-microphone (M/N: HM-168LWP)



< HM-168LWP Speaker-Microphone >

2.3.6. Speaker-microphone (M/N: HM-166LA)



< HM-166LA Speaker-Microphone >

2.3.7. Speaker-microphone (M/N: HM-159LA)



< HM-159LA Speaker-Microphone >

2.3.8. Speaker-microphone (MN: HM-158LA)



< HM-158LA Speaker-Microphone >

2.3.9. Speaker-microphone (MN: HM-153LA)



< HM-153LA Speaker-Microphone >

2.4. SPECIAL CHANGES ON THE D.U.T.'S HARDWARE/SOFTWARE FOR TESTING PURPOSES

N/A

2.5. ANCILLARY EQUIPMENT

N/A

2.6. SPECIFIC OPERATING CONDITIONS

N/A

EXHIBIT 3. SUMMARY OF TEST RESULTS

3.1. LOCATION OF TESTS

All of the measurements described in this report were performed at UltraTech Group of Labs located at:
 3000 Bristol Circle, in the city of Oakville, Province of Ontario, Canada.

All measurements were performed in UltraTech's shielded chamber, 16' x 13' x 8'.

3.2. APPLICABILITY & SUMMARY OF SAR RESULTS

3.2.1. Added Speaker-microphone Accessories test*

Because the highest measured body SAR value ($SAR_{1g} = 3.17$ W/Kg) on a high frequency (469.9MHz) using the added speaker-microphone accessories is lower than the original measured highest body SAR value ($SAR_{1g} = 5.27$ W/Kg) under the similar test configuration as shown above, we did not need to evaluate SAR for the body configurations in each frequency band using updated accessories as per FCC permissive change policy guidelines.

SAR Body Result under the similar configuration with added speaker-microphone:

#	Configuration	Antenna Position	Frequency [MHz]	Channel	MAX SAR _{1g} [W/Kg]
*	Occupational/Controlled Exposure Category Limit				8.0
	¼ helical whip antenna (M/N: FA-SC57U, 430~470 MHz, red ring) 50% duty cycle for PTT MB-94 Belt Clip Speaker Microphone: HM-159LA	FIX	469.9	High	3.17

Original Worst Case SAR Body Results: from ICOM-132-SAR Report

#	Configuration	Antenna Position	Frequency [MHz]	Channel	MAX SAR _{1g} [W/Kg]
*	Occupational/Controlled Exposure Category Limit				8.0
	¼ helical whip antenna (M/N: FA-SC57U, 430~470 MHz, red ring) 50% duty cycle for PTT MB-94 Belt Clip Earphone: SP-13 + VOX/PTT Case: VS-1L	FIX	469.9	High	5.27

* Refer to KDB 178919 D01, Sec 5(b)

3.2.2. Added Cut Antenna test*

The maximum peak spatial - average SAR measured was found to be **3.10** W/Kg for head configuration and **4.78** W/Kg for body configuration with 50% usage-based time-averaging applied for PTT device.

For body configuration tests, all the supplied body-worn accessories were checked through pre-scans and confirmed that those options were not affecting SAR compliance. Therefore the final evaluation for body configuration was performed only with M/N: MB-94 Belt Clip, M/N: HM-159LA Speaker Microphone and M/N: BP-232WP Li-ion rechargeable battery pack.

* Refer to KDB 178919 D01, Sec 5(b)

3.3. SUMMARY OF MEASUREMENT RESULTS*

3.3.1. Body Configuration Results for Added Speaker-microphones: Antennas (FA-SC57U)

#	Configuration	Antenna Position	Frequency [MHz]	SAR _{1g} [W/Kg]	MAX SAR _{1g} [W/Kg]
*	Occupational/Controlled Exposure Category Limit				8.0
01	¼ helical whip antenna (M/N: FA-SC57U, 430~470 MHz, red ring) 50% duty cycle for PTT MB-94 Belt Clip Speaker Microphone: HM-153LA	FIX	469.9	2.96	
02	¼ helical whip antenna (M/N: FA-SC57U, 430~470 MHz, red ring) 50% duty cycle for PTT MB-94 Belt Clip Speaker Microphone: HM-158LA	FIX	469.9	3.09	
03	¼ helical whip antenna (M/N: FA-SC57U, 430~470 MHz, red ring) 50% duty cycle for PTT MB-94 Belt Clip Speaker Microphone: HM-159LA	FIX	469.9	3.17	3.17
04	¼ helical whip antenna (M/N: FA-SC57U, 430~470 MHz, red ring) 50% duty cycle for PTT MB-94 Belt Clip Speaker Microphone: HM-166LA	FIX	469.9	2.95	
05	¼ helical whip antenna (M/N: FA-SC57U, 430~470 MHz, red ring) 50% duty cycle for PTT MB-94 Belt Clip Speaker Microphone: HM-168LWP	FIX	469.9	2.95	

*

3.3.2. Head Configuration Results for Cut Antenna (FA-SC61UC)

#	Configuration	Antenna Position	Frequency [MHz]	Channel	MAX SAR _{1g} [W/Kg]
*	Occupational/Controlled Exposure Category Limit				8.0
6	¼ helical whip cut antenna (M/N: FA-SC61UC, 360~520 MHz, white ring) 50% duty cycle for PTT Antenna Length=165mm	FIX	406.1	Low	3.10
7		FIX	435	Middle	1.23
8		FIX	469.9	High	0.52
9	¼ helical whip antenna (M/N: FA-SC61UC, 360~520 MHz, white ring) 50% duty cycle for PTT Antenna Length=156mm	FIX	406.1	Low	3.03
10		FIX	420	Middle	2.60
11		FIX	469.9	High	0.76
12		FIX	445	Option	-
13	¼ helical whip antenna (M/N: FA-SC61UC, 360~520 MHz, white ring) 50% duty cycle for PTT Antenna Length=148mm	FIX	406.1	Low	2.11
14		FIX	440	Middle	1.92
15		FIX	469.9	High	1.09
16		FIX	420	Option	-
17	¼ helical whip antenna (M/N: FA-SC61UC, 360~520 MHz, white ring) 50% duty cycle for PTT Antenna Length=142mm	FIX	406.1	Low	1.52
18		FIX	430	Middle	2.02
19		FIX	460	High	1.94

3.3.3. Body Configuration Results for Cut Antenna (FA-SC61UC)

#	Configuration	Antenna Position	Frequency [MHz]	Channel	MAX SAR _{1g} [W/Kg]
*	Occupational/Controlled Exposure Category Limit				8.0
20	¼ helical whip cut antenna (M/N: FA-SC61UC, 360~520 MHz, white ring) 50% duty cycle for PTT; Antenna Length=165mm MB-94 Clip, HM-159LA Speaker Microphone	FIX	406.1	Low	4.71
21		FIX	435	Middle	2.11
22		FIX	469.9	High	0.88
23	¼ helical whip antenna (M/N: FA-SC61UC, 360~520 MHz, white ring) 50% duty cycle for PTT; Antenna Length=156mm MB-94 Clip, HM-159LA Speaker Microphone	FIX	406.1	Low	4.78
24		FIX	420	Middle	4.12
25		FIX	469.9	High	1.38
26		FIX	445	Option	2.64
27	¼ helical whip antenna (M/N: FA-SC61UC, 360~520 MHz, white ring) 50% duty cycle for PTT; Antenna Length=148mm MB-94 Clip, HM-159LA Speaker Microphone	FIX	406.1	Low	3.57
28		FIX	440	Middle	3.61
29		FIX	469.9	High	2.07
30		FIX	420	Option	-
31	¼ helical whip antenna (M/N: FA-SC61UC, 360~520 MHz, white ring) 50% duty cycle for PTT; Antenna Length=142mm MB-94 Clip, HM-159LA Speaker Microphone	FIX	406.1	Low	2.79
32		FIX	430	Middle	3.38
33		FIX	460	High	3.35

EXHIBIT 4. SAR SYSTEM CONFIGURATION

4.1. DASY5 SYSTEM OVERVIEW

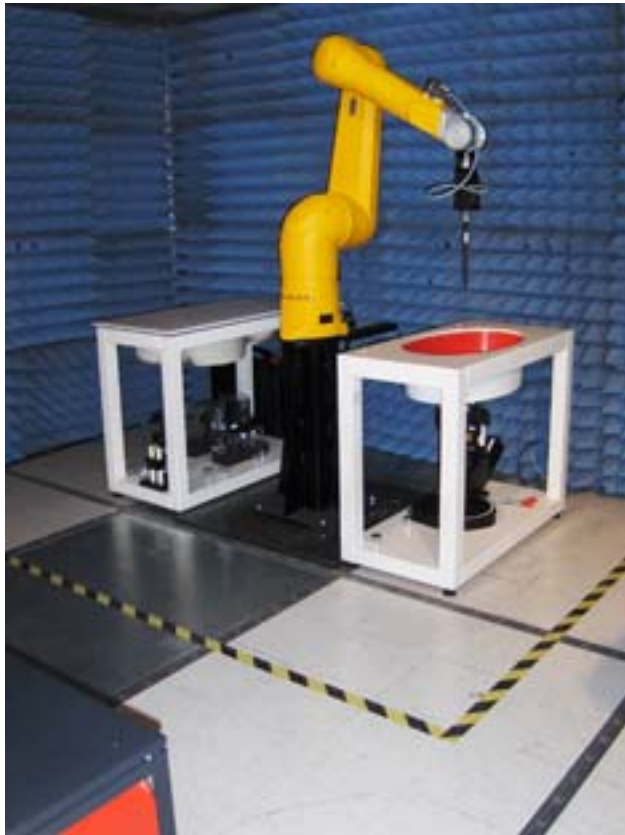

4.1.1. DASY5 System Specification

Positioning Equipment	Computer
DASY5 Measurement Server Data Acquisition Electronics (DAE) Light Beam Unit Device Holder Robot (STAUBLI TX90)	Type: HP Compaq dc7800p Convertible CPU : Intel® Core™ 2 Duo E8500 Memory : 2GB RAM Operating System : Windows XP Professional Monitor : HP L1950g LCD

4.1.1.1. DASY5 Measurement Server

The DASY5 measurement server is based on a PC/104 CPU board with a 400MHz Intel ULV Celeron, 128MB chipdisk and 128MB RAM. The necessary circuits for communication with the DAE4 (or DAE3) electronics box, as well as the 16 bit AD converter system for optical detection and digital I/O interface are contained on the DASY5 I/O board, which is directly connected to the PC/104 bus of the CPU board.

The measurement server performs all real-time data evaluation of field measurements and surface detection, controls robot movements and handles safety operation. The PC operating system cannot interfere with these time critical processes. All connections are supervised by a watchdog, and disconnection of any of the cables to the measurement server will automatically disarm the robot and disable all program-controlled robot movements. Furthermore, the measurement server is equipped with an expansion port which is reserved for future applications. Please note that this expansion port does not have a standardized pinout, and therefore only devices provided by SPEAG can be connected. Devices from any other supplier could seriously damage the measurement server.

4.1.1.2. Data Acquisition Electronics

The data acquisition electronics (DAE4 or DAE3) consist of a highly sensitive electrometer-grade preamplifier with auto-zeroing, a channel and gain-switching multiplexer, a fast 16 bit AD-converter and a command decoder with a control logic unit. Transmission to the measurement server is accomplished through an optical downlink for data and status information, as well as an optical uplink for commands and the clock.

The mechanical probe mounting device includes two different sensor systems for frontal and sideways probe contacts. They are used for mechanical surface detection and probe collision detection.

The input impedance of both the DAE4 as well as of the DAE3 box is 200MOhm; the inputs are symmetrical and floating. Common mode rejection is above 80 dB.

4.1.1.3. Dosimetric Probes

These probes are specially designed and calibrated for use in liquids with high permittivity. They should not be used in air, since the spherical isotropy in air is poor (-2 dB). The dosimetric probes have special calibrations in various liquids at different frequencies.



4.1.1.3.1. ES3DV3 Isotropic E-Filed Probe

Construction	Symmetrical design with triangular core Interleaved sensors Built-in shielding against static charges PEEK enclosure material (resistant to organic solvents, e.g., DGBE)
Calibration	Basic Broad Band Calibration in air Conversion Factors (CF) for HSL 900 and HSL 1750 Additional CF for other liquids and frequencies
Frequency	10 MHz to 4 GHz Linearity ± 0.2 dB (30 MHz to 4 GHz)
Directivity	± 0.2 dB in HSL (rotation around probe axis) ± 0.3 dB in tissue material (rotation normal to probe axis)
Dynamic Range	5 μ W/g to > 100 mW/g Linearity: ± 0.2 dB
Dimensions	Overall length: 330 mm (Tip: 20 mm) Tip diameter: 3.9 mm (Body: 12 mm) Distance from probe tip to dipole centers: 2.0 mm

4.1.1.3.2. EX3DV4 Isotropic E-Filed Probe

Construction	Symmetrical design with triangular core Built-in shielding against static charges PEEK enclosure material (resistant to organic solvents, e.g., DGBE)
Calibration	Basic Broad Band Calibration in air Conversion Factors (CF) for HSL 900 and HSL 1750 Additional CF for other liquids and frequencies
Frequency	10 MHz to > 6 GHz Linearity: ± 0.2 dB (30 MHz to 6 GHz)
Directivity	± 0.3 dB in HSL (rotation around probe axis) ± 0.5 dB in tissue material (rotation normal to probe axis)
Dynamic Range	10 μ W/g to > 100 mW/g Linearity: ± 0.2 dB (noise: typically < 1 μ W/g)
Dimensions	Overall length: 330 mm (Tip: 20 mm) Tip diameter: 2.5 mm (Body: 12 mm) Typical distance from probe tip to dipole centers: 1 mm

4.1.2. DASYS SAR SYSTEM block diagram

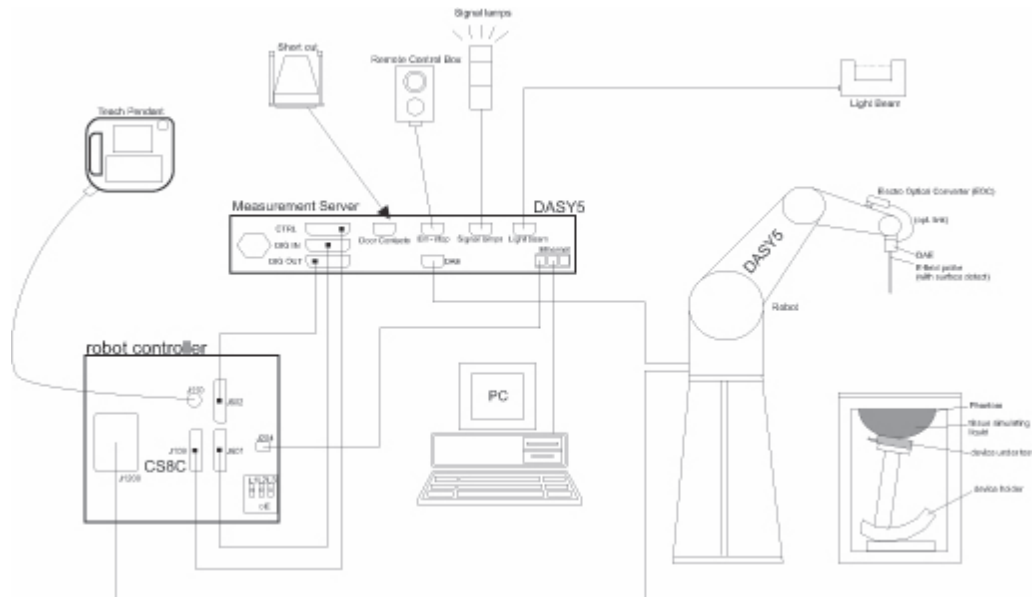

4.2. SAR TEST PHANTOMS

4.2.1. SAM Twin Phantom



For Head mounted devices placed next to the ear, the phantom used in the evaluation of the RF exposure of the user of the wireless device is an IEEE P1528 compliant SAM Twin phantom, shaped like a human head and filled with a mixture simulating the dielectric characteristics of the brain. A left sided head and a right sided head are evaluated to determine the worst case orientation for SAR.

4.2.2. ELI 4.0 Phantom



For body mounted and frontal held push-to-talk devices, an IEC 62209-2 compliant Oval Flat Phantom (ELI 4.0) with a base plate thickness of 2mm is used.

ULTRATECH GROUP OF LABS

3000 Bristol Circle, Oakville, Ontario, Canada L6H 6G4

Tel. #: 905-829-1570, Fax. #: 905-829-8050, Email: vic@ultratech-labs.com, Website: <http://www.ultratech-labs.com>

File #: ICOM-286Q-SAR

February 1, 2012

- All test results contained in this engineering test report are traceable to National Institute of Standards and Technology (NIST)

EXHIBIT 5. SAR DATA ACQUISITION METHODOLOGY

5.1. SAR MEASUREMENT PROCEDURE

The goal of the measurement process is to scan the phantom over a selected area in order to find the region of highest levels of RF energy and then to obtain a single value for the peak spatial-average of SAR over a volume that would contain one gram (in the shape of a cube) of biological tissue. The test procedure, of course, measures SAR in the simulated tissue.

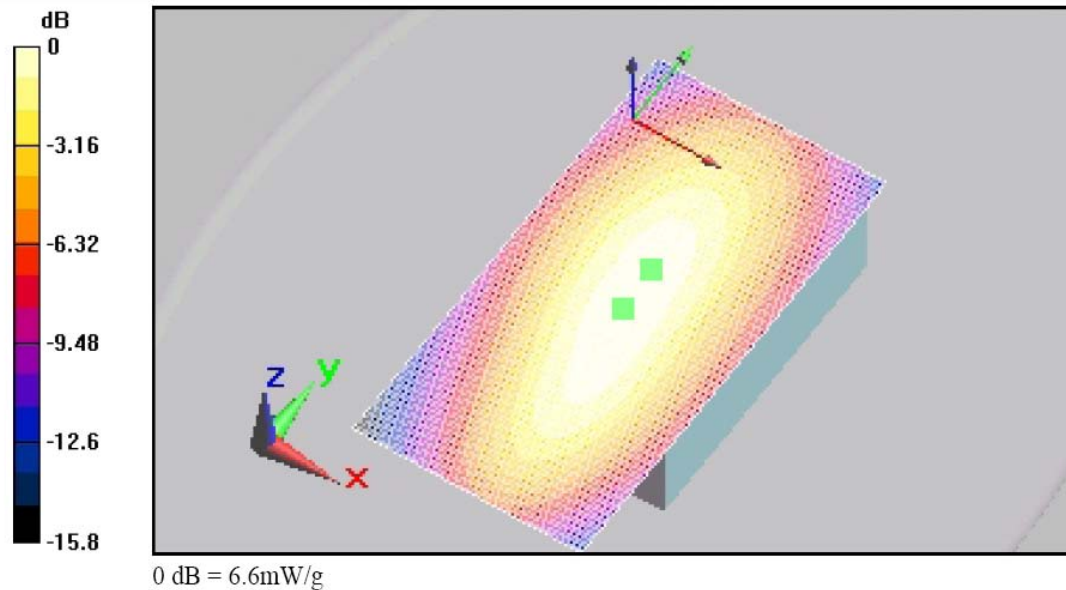

< Area scan >

The software requests the user to move the probe to locations at two extreme corners of a rectangle that encloses the area to be scanned. An arbitrary origin and the spatial resolution for the scan are also specified. Under program control, the scan is performed automatically by the robot-guided probe.

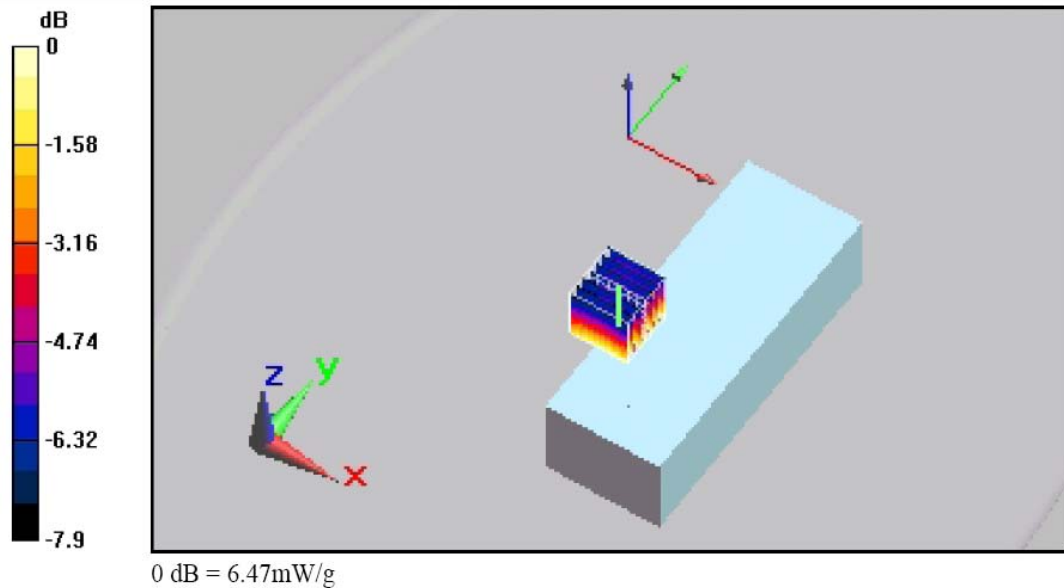

< Zoom Scan >

The DASY5 software includes all numerical procedures necessary to evaluate the spatial peak SAR values.

Based on the Draft: SCC-34, SC-2, WG-2 - Computational Dosimetry, IEEE P1529/D0.0 (Draft Recommended Practice for Determining the Spatial-Peak Specific Absorption Rate (SAR) Associated with the Use of Wireless Handsets - Computational Techniques), a new algorithm has been implemented. The spatial-peak SAR can be computed over any required mass.

The base for the evaluation is a "cube" measurement in a volume of $(30\text{mm})^3$ ($7 \times 7 \times 7$ points). The measured volume must include the 1 g and 10 g cubes with the highest averaged SAR values. For that purpose, the center of the measured volume is aligned to the interpolated peak SAR value of a previously performed area scan. If the 10g cube or both cubes are not entirely inside the measured volumes, the system issues a warning regarding the evaluated spatial peak values within the postprocessing engine (SEMCAD X). This means that if the measured volume is shifted, higher values might be possible. To get the correct values you can use a finer measurement grid for the area scan. In complicated field distributions, a large grid spacing for the area scan might miss some details and give an incorrectly interpolated peak location.

The entire evaluation of the spatial peak values is performed within the postprocessing engine (SEMCAD X). The system always gives the maximum values for the 1 g and 10 g cubes. The algorithm to find the cube with highest averaged SAR is divided into the following stages:

1. extraction of the measured data (grid and values) from the Zoom Scan
2. calculation of the SAR value at every measurement point based on all stored data (A/D values and measurement parameters)
3. generation of a high-resolution mesh within the measured volume
4. interpolation of all measured values from the measurement grid to the high-resolution grid
5. extrapolation of the entire 3-D field distribution to the phantom surface over the distance from sensor to surface

ULTRATECH GROUP OF LABS

3000 Bristol Circle, Oakville, Ontario, Canada L6H 6G4

Tel. #: 905-829-1570, Fax. #: 905-829-8050, Email: vic@ultratech-labs.com, Website: <http://www.ultratech-labs.com>

File #: ICOM-286Q-SAR

February 1, 2012

- All test results contained in this engineering test report are traceable to National Institute of Standards and Technology (NIST)

6. calculation of the averaged SAR within masses of 1 g and 10 g

The significant parts are outlined in more detail within the following sections.

5.1.1. *Interpolation, Extrapolation and Detection of Maxima*

The probe is calibrated at the center of the dipole sensors which is located 1 to 2.7mm away from the probe tip. During measurements, the probe stops shortly above the phantom surface, depending on the probe and the surface detecting system. Both distances are included as parameters in the probe configuration file. The software always knows exactly how far away the measured point is from the surface. As the probe cannot directly measure at the surface, the values between the deepest measured point and the surface must be extrapolated.

In DASY5, the choice of the coordinate system defining the location of the measurement points has no influence on the uncertainty of the interpolation, Maxima Search and extrapolation routines. The interpolation, extrapolation and maximum search routines are all based on the modified Quadratic Shepard's method.

Thereby, the interpolation scheme combines a least-square fitted function method and a weighted average method which are the two basic types of computational interpolation and approximation. The DASY5 routines construct a once-continuously differentiable function that interpolates the measurement values as follows:

- For each measurement point a trivariate (3-D) / bivariate (2-D) quadratic is computed. It interpolates the measurement values at the data point and forms a least-square fit to neighboring measurement values.
- the spatial location of the quadratic with respect to the measurement values is attenuated by an inverse distance weighting. This is performed since the calculated quadratic will fit measurement values at nearby points more accurate than at points located further away.
- After the quadratics are calculated for at all measurement points, the interpolating function is calculated as a weighted average of the quadratics.

There are two control parameters that govern the behavior of the interpolation method. One specifies the number of measurement points to be used in computing the least-square fits for the local quadratics. These measurement points are the ones nearest the input point for which the quadratic is being computed. The second parameter specifies the number of measurement points that will be used in calculating the weights for the quadratics to produce the final function. The input data points used there are the ones nearest the point at which the interpolation is desired. Appropriate defaults are chosen for each of the control parameters

The trivariate quadratics that have been previously computed for the 3-D interpolation and whose input data are at the closest distance from the phantom surface, are used in order to extrapolate the fields to the surface of the phantom.

In order to determine all the field maxima in 2-D (Area Scan) and 3-D (Zoom Scan), the measurement grid is refined by a default factor of 10 and the interpolation function is used to evaluate all field values between corresponding measurement points. Subsequently, a linear search is applied to find all the candidate maxima. In a last step, non physical maxima are removed and only those maxima which are within 2 dB of the global maximum value are retained.

Important: To be processable by the interpolation/extrapolation scheme, the Area Scan requires at least 6 measurement points. The Cube Scan requires at least 10 measurement points to allow an application of these algorithms.

In the Area Scan, the gradient of the interpolation function is evaluated to find all the extrema of the SAR distribution. The uncertainty on the locations of the extrema is less than 1/20 of the grid size. Only local maxima within -2 dB of the global maximum are searched and passed for the Cube Scan measurement.

In the Cube Scan, the interpolation function is used to extrapolate the Peak SAR from the lowest measurement points to the inner phantom surface (the extrapolation distance). The uncertainty increases with the extrapolation distance. To keep the uncertainty within 1% for the 1 g and 10 g cubes, the extrapolation distance should not be larger than 5mm.

5.1.2. *Averaging and Determination of Spatial Peak SAR*

The interpolated data is used to average the SAR over the 1g and 10g cubes by spatially discretizing the entire measured volume. The resolution of this spatial grid used to calculate the averaged SAR is 1mm or about 42875 interpolated points. The resulting volumes are defined as cubical volumes containing the appropriate tissue parameters that are centered at the location. The location is defined as the center of the incremental volume (voxel).

The spatial-peak SAR must be evaluated in cubical volumes containing a mass that is within 5% of the required mass. The cubical volume centered at each location, as defined above, should be expanded in all directions until the desired value for the mass is reached, with no surface boundaries of the averaging volume extending beyond the outermost surface of the considered region. In addition, the cubical volume should not consist of more than 10% of air. If these conditions are not satisfied then the center of the averaging volume is moved to the next location. Otherwise, the exact size of the final sampling cube is found using an inverse polynomial approximation algorithm, leading to results with improved accuracy. If one boundary of the averaging volume reaches the boundary of the measured volume during its expansion, it will not be evaluated at all. Reference is kept of all locations used and those not used for averaging the SAR. All average SAR values are finally assigned to the centered location in each valid averaging volume.

All locations included in an averaging volume are marked to indicate that they have been used at least once. If a location has been marked as used, but has never been assigned to the center of a cube, the highest averaged SAR value of all other cubical volumes which have used this location for averaging, is assigned to this location. Only those locations that are not part of any valid averaging volume should be marked as unused. For the case of an unused location, a new averaging volume must be constructed which will have the unused location centered at one surface of the cube. The remaining five surfaces are expanded evenly in all directions until the required mass is enclosed, regardless of the amount of included air. Of the six possible cubes with one surface centered on the unused location, the smallest cube is used, which still contains the required mass.

If the final cube containing the highest averaged SAR touches the surface of the measured volume, an appropriate warning is issued within the postprocessing engine.

5.1.3. *Evaluation Errors*

5.1.3.1. *Cube shape*

The mentioned procedures search for the maximum averaged 1g and 10g volumes of cubical shape according to the ANSI and ICNIRP standard. A density of 1000 kg/m³ is used to represent the head tissue density and not the tissue simulating liquid density.

5.1.3.2. *Extrapolation*

For the extrapolation the distance must be specified in the Area Scan and Zoom Scan Jobs. The distance is defined as the distance between the probe sensor center and the phantom surface. The recommended distance is 4-5 mm.

5.1.3.3. Boundary effects

The dosimetric probes are calibrated in a gradient field with energy flow and decay in direction of the probe axis. During calibration the probe tip is completely surrounded by the simulating solution. If the probe is used in the immediate vicinity of a media boundary, the field in the probe is altered due to interaction with the field in the boundary and the probe sensitivity changes. The influence of the boundary effect depends on the probe construction, the media parameters and the probe orientation with respect to the boundary. It disappears at a distance of 1mm (E1D-probe) to 5mm (ET3D-probes) between the probe tip and the boundary. The boundary effect must be considered in the extrapolation to the surface.

EXHIBIT 6. MEASUREMENTS, EXAMINATIONS & TEST DATA

6.1. TEST CONFIGURATIONS

D.U.T. Information		Condition	
Product Name	UHF Transceiver	Robot Type	6 Axis
Model Number	IC-F4031S	Scan Type	SAR – Area/Zoom/Att. Vs Depth
Serial Number	7200001	Measured Field	E
Frequency Band [MHz]	400-470	Phantom Type	2 _{mm} base Flat Phantom
Frequency Tested [MHz]	406.1,420,430,435,440,445, 460, 469.9	Phantom Position	Waist
Rated Conducted Power [W]	4W (High power mode)	Room Temperature [°C]	24.0 ± 1
Antenna Type	ICOM Helical whip antenna (M/N: FA-SC57U, 430-470 MHz, red ring) ICOM helical whip cut antenna (M/N: FA-SC61UC, 360~520 MHz, white ring)	Room Humidity [%]	40 ± 10
Modulation	FM	Tissue Temperature [°C]	20.0 ± 1
Worst Case Duty Cycle	50 %		
Duty Cycle Tested	100 %		
Source(or Usage)-Based Time-Average Factor	0.5 (mechanical PTT button)		

Type of Tissue	Brain	Muscle
Test Frequency [MHz]	450	450
Target Conductivity [S/m]	0.87	0.94
Measured Conductivity [S/m]	0.87 (0.3 %)	0.94 (-0.1 %)
Target Dielectric Constant	43.5	56.7
Measured Dielectric Constant	43.4 (-0.3 %)	56.3 (-0.8 %)
Penetration Depth (Plane Wave Excitation) [mm]	42.8	44.5
Probe Model Number	ES3DV3	ES3DV3
Probe Serial Number	3208	3208
Probe Orientation	Isotropic	Isotropic
Probe Sensor Offset [mm]	1	1
Probe Tip Diameter [mm]	3.9	3.9
Conversion Factor (γ)	7.1 (+/- 8%)	7.0 (+/- 8%)

6.2. GENERAL TEST SETUP

6.2.1. *Equipment Configuration*

Power and signal distribution, grounding, interconnecting cabling and physical placement of equipment of a test system shall simulate the typical application and usage in so far as is practicable, and shall be in accordance with the relevant product specifications of the manufacturer.

The configuration that tends to maximize the D.U.T's emission or minimize its immunity is not usually intuitively obvious and in most instances selection will involve some trial and error testing. For example, interface cables may be moved or equipment re-orientated during initial stages of testing and the effects on the results observed.

Only configurations within the range of positions likely to occur in normal use need to be considered.

The configuration selected shall be fully detailed and documented in the test report, together with the justification for selecting that particular configuration.

6.2.2. *Exercising Equipment*

The exercising equipment and other auxiliary equipment shall be sufficiently decoupled from the D.U.T. so that the performance of such equipment does not significantly influence the test results.

6.3. PHOTOGRAPHS OF TISSUE DEPTH

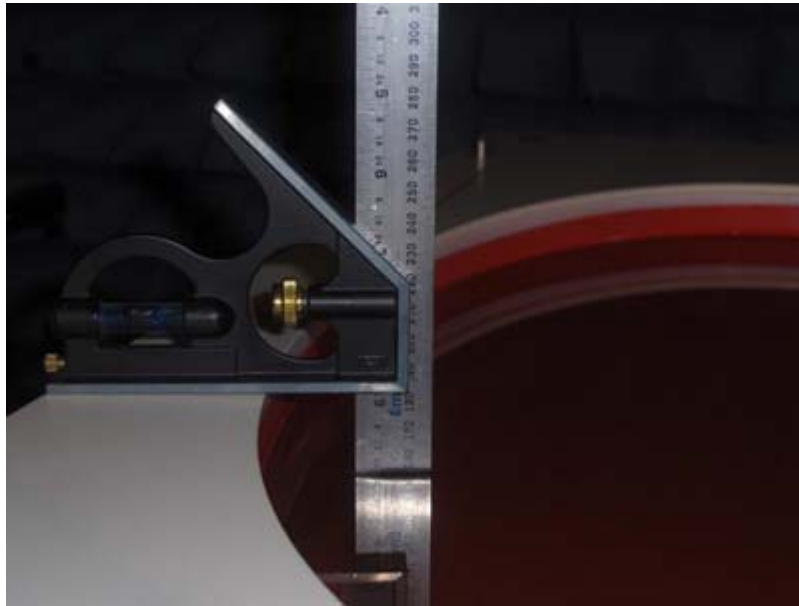

< Phantom filled with head tissue: liquid level = 150mm ± 5mm >

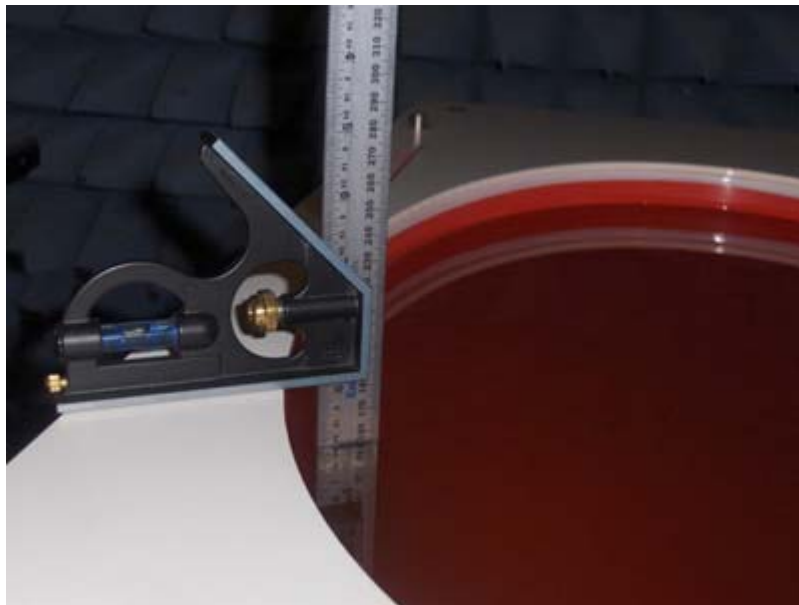

< Phantom filled with body tissue liquid: liquid level = 150mm ± 5mm >

ULTRATECH GROUP OF LABS

3000 Bristol Circle, Oakville, Ontario, Canada L6H 6G4

Tel. #: 905-829-1570, Fax. #: 905-829-8050, Email: vic@ultratech-labs.com, Website: <http://www.ultratech-labs.com>

File #: ICOM-286Q-SAR

February 1, 2012

- All test results contained in this engineering test report are traceable to National Institute of Standards and Technology (NIST)

6.4. PHOTOGRAPHS OF D.U.T. POSITION

6.4.1. *Body Configuration for Added Speaker-microphone: Antennas (FA-SC57U)*



Back side of EUT in parallel to the phantom with the belt-clip (M/N: MB-94) in contact, attached 5 different- type Speaker-microphones separately

6.4.2. Head Configuration for Added Cut Antenna (FA-SC61UC)

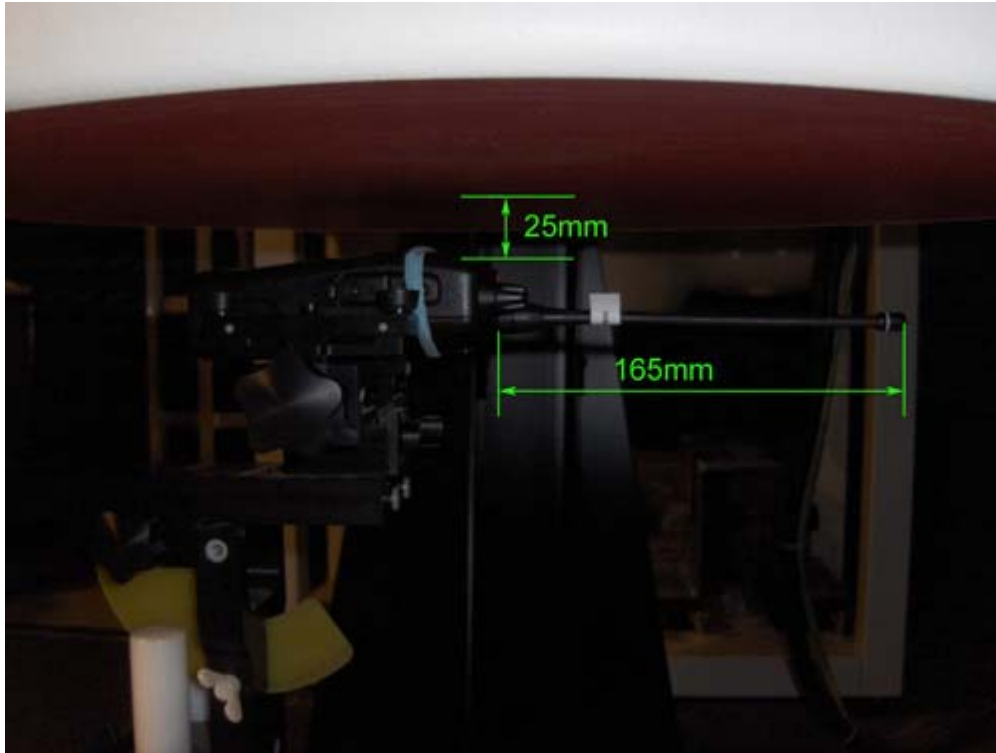

< FA-SC61UC cut antenna with the length of 165mm >

Remark: Distance between EUT and phantom = 25 mm

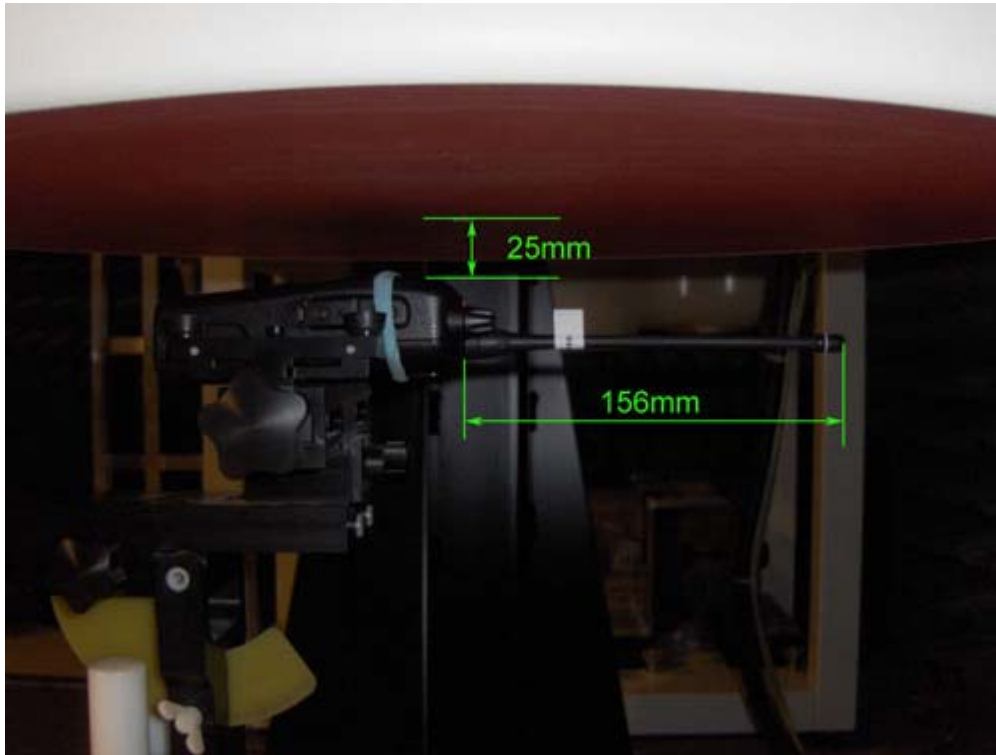

< FA-SC61UC cut antenna with the length of 156mm >

Remark: Distance between EUT and phantom = 25 mm

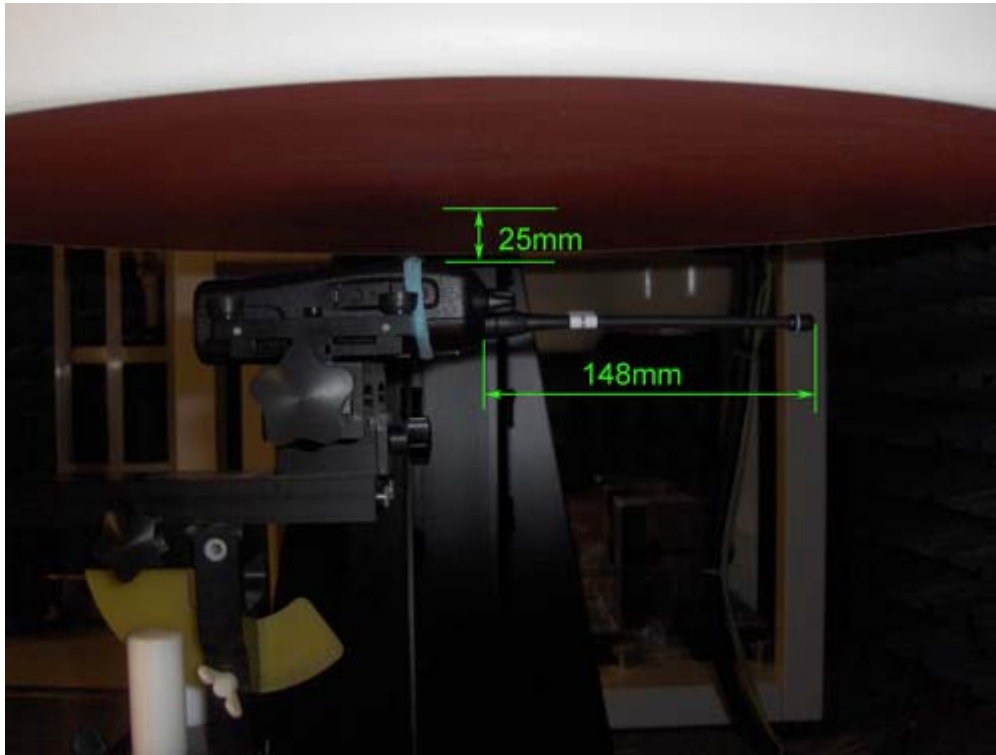

< FA-SC61UC cut antenna with the length of 148mm >

Remark: Distance between EUT and phantom = 25 mm

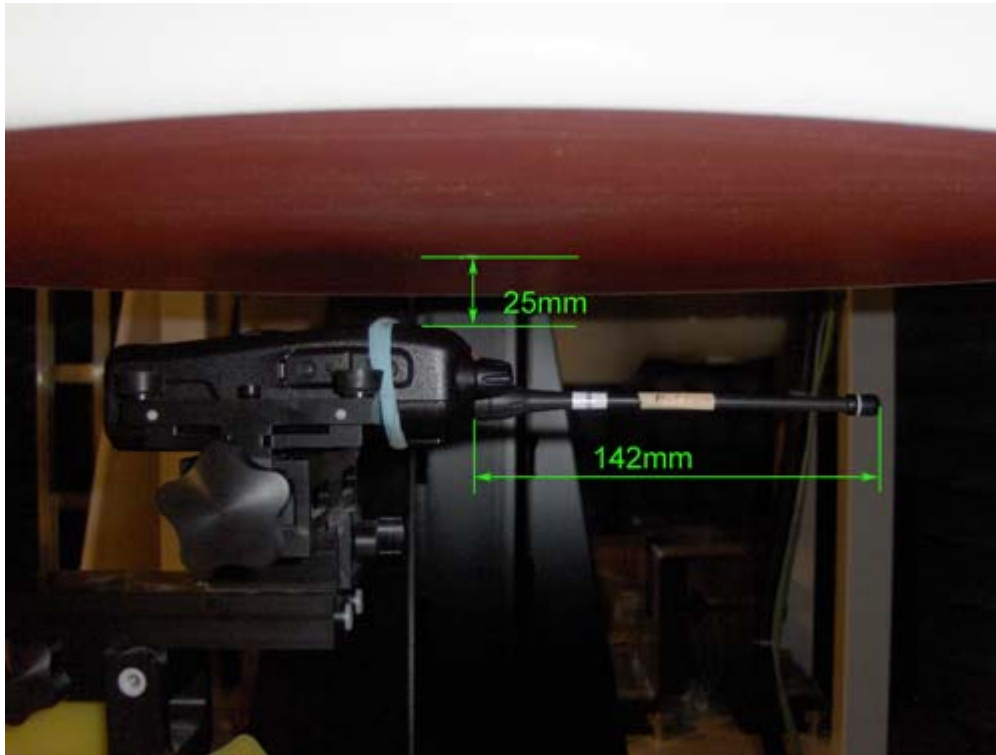

< FA-SC61UC cut antenna with the length of 142mm >

Remark: Distance between EUT and phantom = 25 mm

6.4.3. Body Configuration for Added Cut Antenna (FA-SC61UC)

Back side of EUT in parallel to the phantom with the belt-clip in contact, Belt-clip (M/N: MB-94) and Speaker-microphone (M/N: HM-159LA)



< FA-SC61UC cut antenna with the length of 165mm >

Remark: Belt clip touch the phantom bottom



< FA-SC61UC cut antenna with the length of 156mm >

Remark: Belt clip touch the phantom bottom



< FA-SC61UC cut antenna with the length of 148mm >

Remark: Belt clip touch the phantom bottom



< FA-SC61UC cut antenna with the length of 142mm >

Remark: Belt clip touch the phantom bottom

6.5. SAR MEASUREMENT DATA

6.5.1. Body Configuration Results for Added Speaker-microphones: Antenna (FA-SC57U)

#	Configuration	Antenna Position	Frequency [MHz]	SAR _{1g} [W/Kg]	MAX SAR _{1g} [W/Kg]
*	Occupational/Controlled Exposure Category Limit				8.0
01	¼ helical whip antenna (M/N: FA-SC57U, 430~470 MHz, red ring) 50% duty cycle for PTT MB-94 Belt Clip Speaker Microphone: HM-153LA	FIX	469.9	2.96	
02	¼ helical whip antenna (M/N: FA-SC57U, 430~470 MHz, red ring) 50% duty cycle for PTT MB-94 Belt Clip Speaker Microphone: HM-158LA	FIX	469.9	3.09	
03	¼ helical whip antenna (M/N: FA-SC57U, 430~470 MHz, red ring) 50% duty cycle for PTT MB-94 Belt Clip Speaker Microphone: HM-159LA	FIX	469.9	3.17	3.17
04	¼ helical whip antenna (M/N: FA-SC57U, 430~470 MHz, red ring) 50% duty cycle for PTT MB-94 Belt Clip Speaker Microphone: HM-166LA	FIX	469.9	2.95	
05	¼ helical whip antenna (M/N: FA-SC57U, 430~470 MHz, red ring) 50% duty cycle for PTT MB-94 Belt Clip Speaker Microphone: HM-168LWP	FIX	469.9	2.95	

6.5.1.1. 1/4 helical whip antenna (M/N: FA-SC57U); Belt Clip (M/N: MB-94), Speaker Microphone (M/N: HM-153LA); 469.9 MHz; #01

Test Laboratory: Ultratech Group of Labs

File Name: [ICOM-286Q_FA-SC57U_Body_469.9MHz\(Hf\)_153LA.da52](#)**DUT: ICOM UHF Transceiver; Type: IC-F4031S; Serial: 7200001**

Communication System: CW; Frequency: 469.9 MHz; Duty Cycle: 1:1

Medium parameters used: $f = 470$ MHz; $\sigma = 0.954$ mho/m; $\epsilon_r = 55.983$; $\rho = 1000$ kg/m³

Phantom section: Flat Section

DASY5 Configuration:

- Probe: ES3DV3 - SN3208; ConvF(7, 7, 7); Calibrated: 3/15/2011
- Sensor-Surface: 4mm (Mechanical Surface Detection), Sensor-Surface: 3.4mm (Mechanical Surface Detection)
- Electronics: DAE4 Sn874;
- Phantom: ELI 4.0; Type: QD OVA 001 BB; Serial: 1057
- Measurement SW: DASY52, Version 52.8 (0); SEMCAD X Version 14.6.4 (4989)

Configuration_Body_FA-SC57U_Hf/Body Back, d=0mm, Pin=4W (ES-Probe)/FindMax (11x41x1): Measurement grid: dx=20mm, dy=20mm

Maximum value of SAR (interpolated) = 6.829 mW/g

Configuration_Body_FA-SC57U_Hf/Body Back, d=0mm, Pin=4W (ES-Probe)/Area Scan (61x81x1): Measurement grid: dx=15mm, dy=15mm

Maximum value of SAR (interpolated) = 6.961 mW/g

Configuration_Body_FA-SC57U_Hf/Body Back, d=0mm, Pin=4W (ES-Probe)/Zoom Scan (5x5x7) (7x7x7)/Cube 0:

Measurement grid: dx=5mm, dy=5mm, dz=5mm

Reference Value = 85.438 V/m; Power Drift = -0.07 dB

Peak SAR (extrapolated) = 8.3040

SAR(1 g) = 5.92 mW/g; SAR(10 g) = 4.32 mW/g (SAR corrected for target medium)

Maximum value of SAR (measured) = 6.318 mW/g

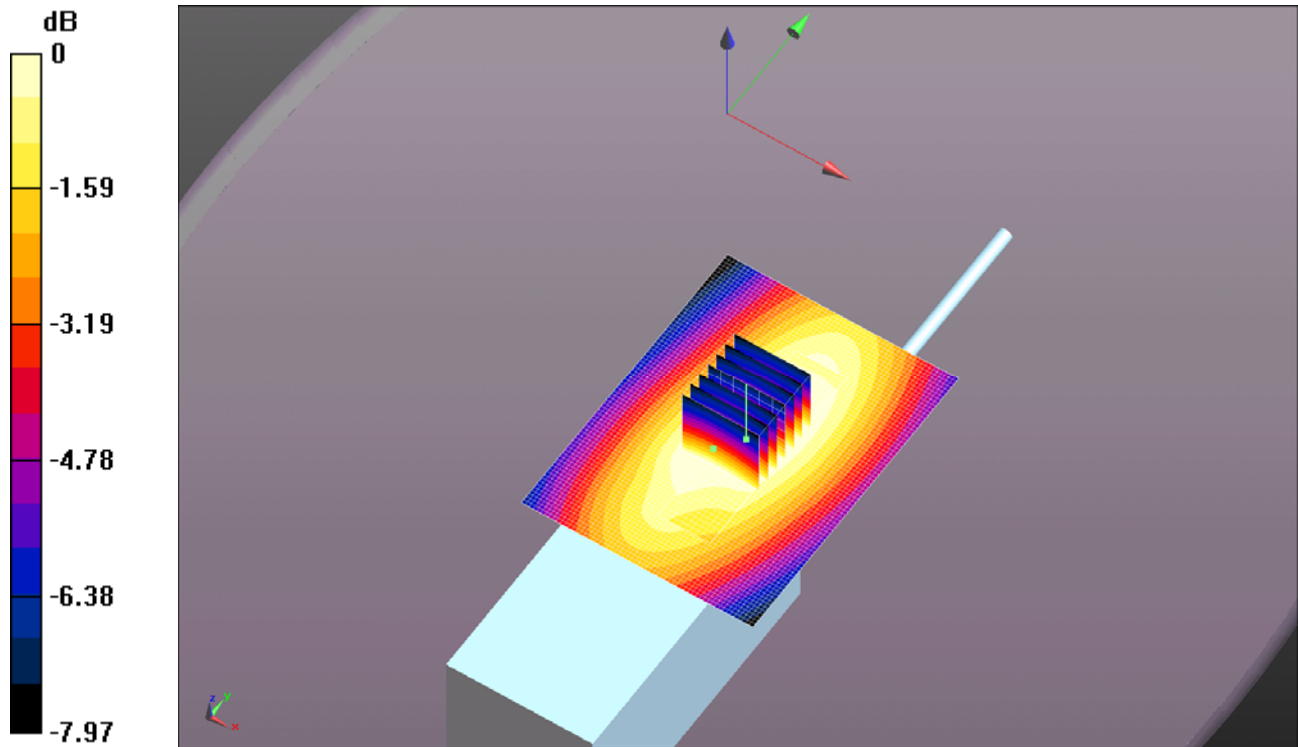

0 dB = 6.320mW/g = 16.01 dB mW/g

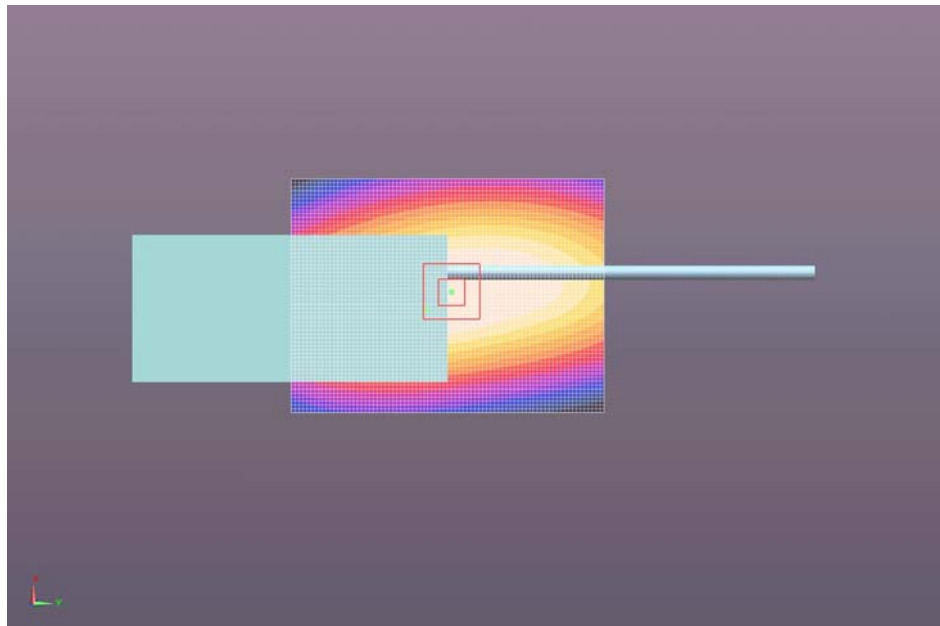

ULTRATECH GROUP OF LABS

3000 Bristol Circle, Oakville, Ontario, Canada L6H 6G4
Tel. #: 905-829-1570, Fax. #: 905-829-8050, Email: vic@ultratech-labs.com, Website: <http://www.ultratech-labs.com>

File #: ICOM-286Q-SAR

February 1, 2012

- All test results contained in this engineering test report are traceable to National Institute of Standards and Technology (NIST)

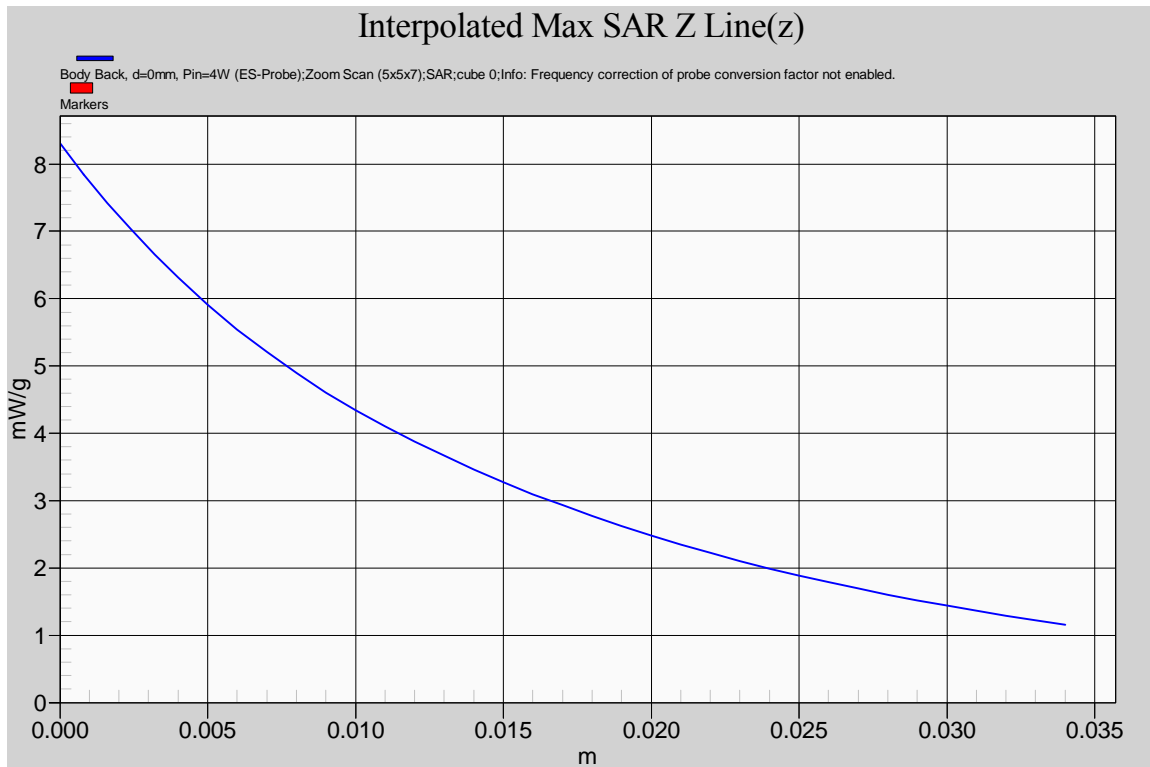

ULTRATECH GROUP OF LABS

3000 Bristol Circle, Oakville, Ontario, Canada L6H 6G4
Tel. #: 905-829-1570, Fax. #: 905-829-8050, Email: vic@ultratech-labs.com, Website: <http://www.ultratech-labs.com>

File #: ICOM-286Q-SAR

February 1, 2012

- All test results contained in this engineering test report are traceable to National Institute of Standards and Technology (NIST)

6.5.1.2. 1/4 helical whip antenna (M/N: FA-SC57U); Belt Clip (M/N: MB-94), Speaker Microphone (M/N: HM-158LA); 469.9 MHz; #02

Test Laboratory: Ultratech Group of Labs

File Name: [ICOM-286Q_FA-SC57U_Body_469.9MHz\(Hf\)_158LA.da52](#)**DUT: ICOM UHF Transceiver; Type: IC-F4031S; Serial: 7200001**

Communication System: CW; Frequency: 469.9 MHz; Duty Cycle: 1:1

Medium parameters used: $f = 470$ MHz; $\sigma = 0.954$ mho/m; $\epsilon_r = 55.983$; $\rho = 1000$ kg/m³

Phantom section: Flat Section

DASY5 Configuration:

- Probe: ES3DV3 - SN3208; ConvF(7, 7, 7); Calibrated: 3/15/2011
- Sensor-Surface: 4mm (Mechanical Surface Detection), Sensor-Surface: 3.4mm (Mechanical Surface Detection)
- Electronics: DAE4 Sn874;
- Phantom: ELI 4.0; Type: QD OVA 001 BB; Serial: 1057
- Measurement SW: DASY52, Version 52.8 (0); SEMCAD X Version 14.6.4 (4989)

Configuration_Body_FA-SC57U_Hf/Body Back, d=0mm, Pin=4W (ES-Probe)/FindMax (11x41x1): Measurement grid: dx=20mm, dy=20mm

Maximum value of SAR (interpolated) = 7.319 mW/g

Configuration_Body_FA-SC57U_Hf/Body Back, d=0mm, Pin=4W (ES-Probe)/Area Scan (61x81x1): Measurement grid: dx=15mm, dy=15mm

Maximum value of SAR (interpolated) = 7.375 mW/g

Configuration_Body_FA-SC57U_Hf/Body Back, d=0mm, Pin=4W (ES-Probe)/Zoom Scan (5x5x7) (7x7x7)/Cube 0:

Measurement grid: dx=5mm, dy=5mm, dz=5mm

Reference Value = 86.700 V/m; Power Drift = 0.09 dB

Peak SAR (extrapolated) = 8.6670

SAR(1 g) = 6.18 mW/g; SAR(10 g) = 4.49 mW/g (SAR corrected for target medium)

Maximum value of SAR (measured) = 6.582 mW/g

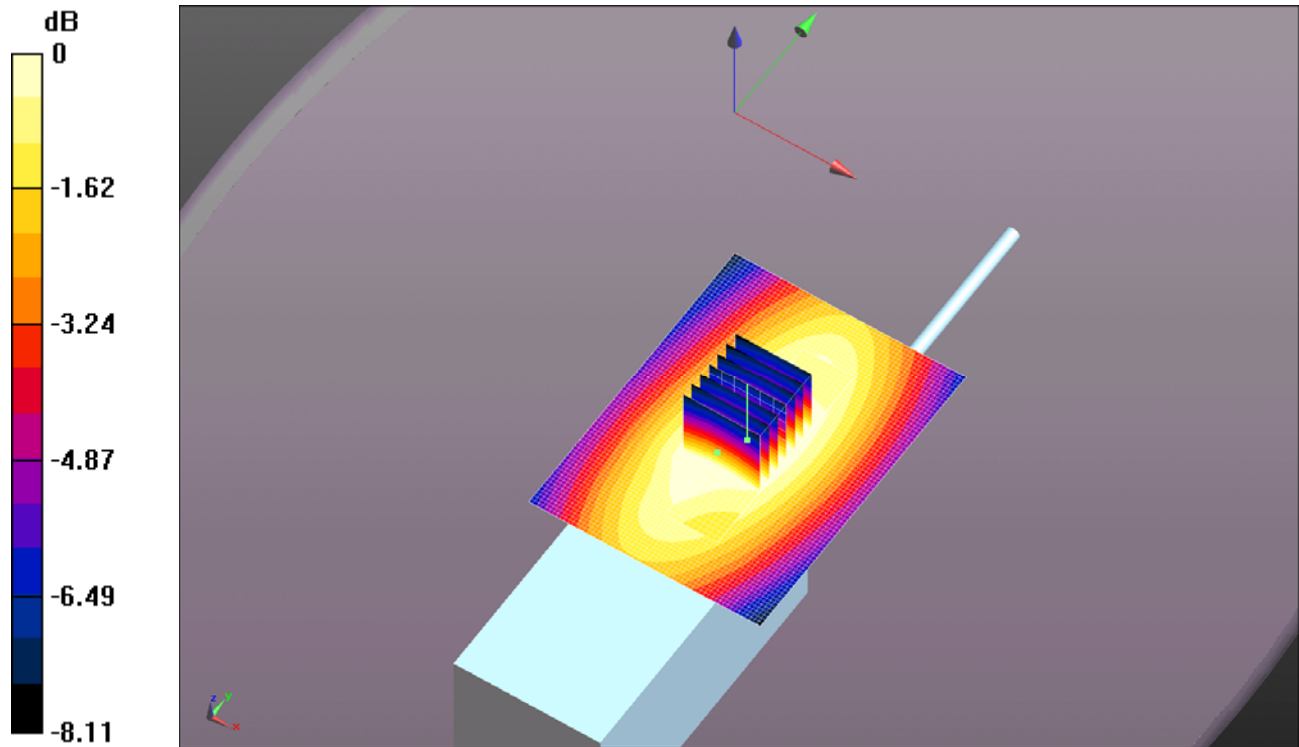

0 dB = 6.580mW/g = 16.36 dB mW/g

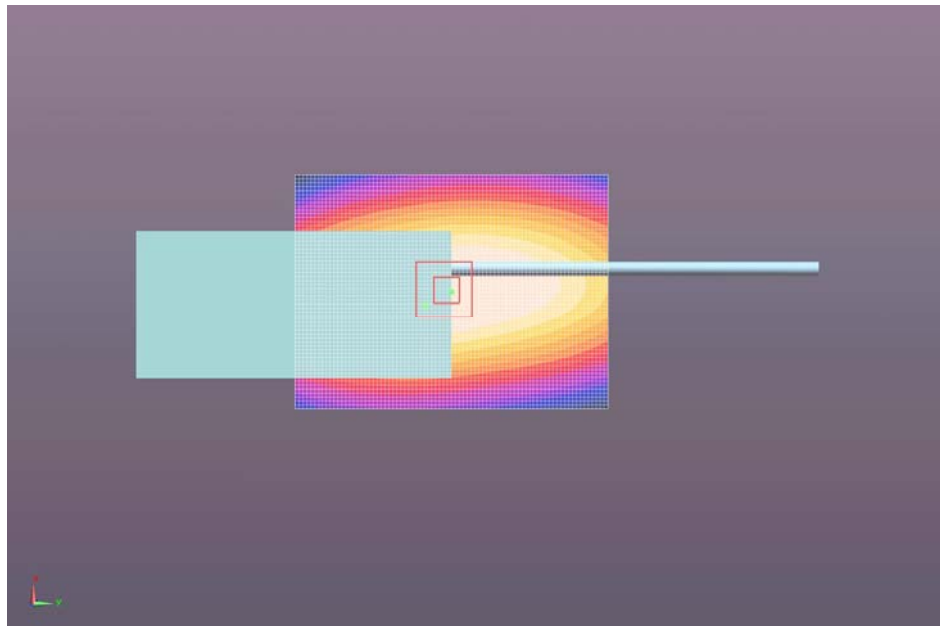

ULTRATECH GROUP OF LABS

3000 Bristol Circle, Oakville, Ontario, Canada L6H 6G4
Tel. #: 905-829-1570, Fax. #: 905-829-8050, Email: vic@ultratech-labs.com, Website: <http://www.ultratech-labs.com>

File #: ICOM-286Q-SAR

February 1, 2012

- All test results contained in this engineering test report are traceable to National Institute of Standards and Technology (NIST)

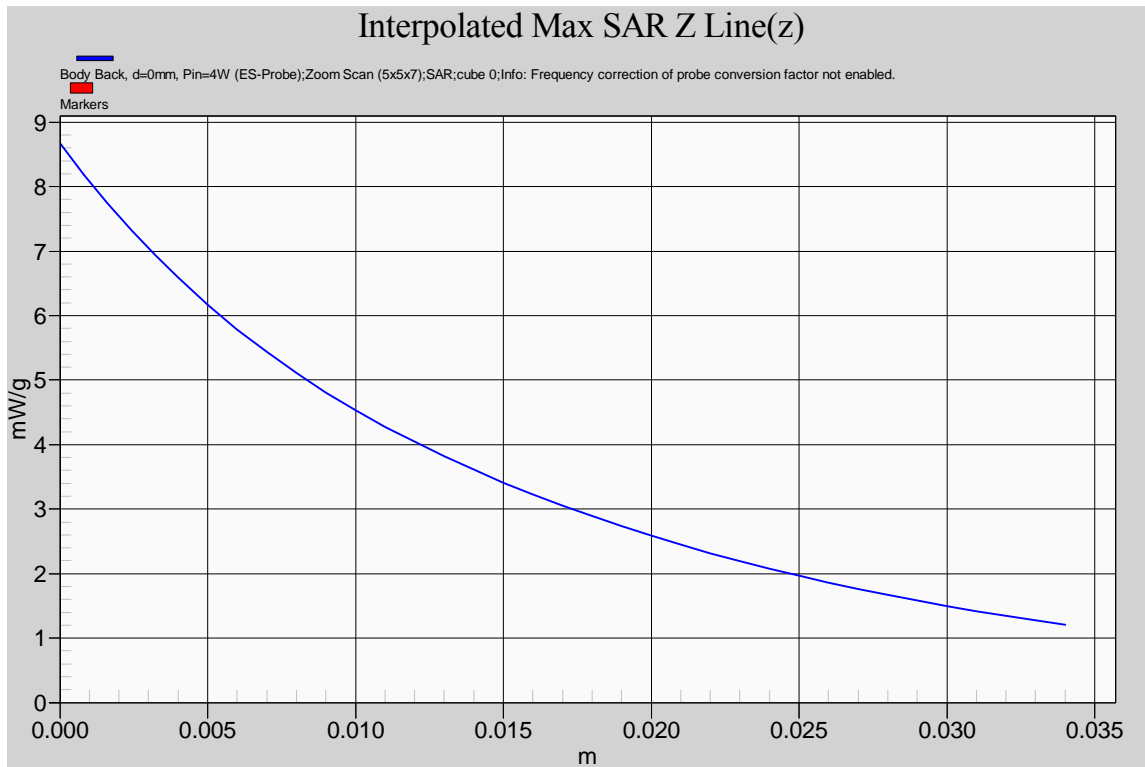

ULTRATECH GROUP OF LABS

3000 Bristol Circle, Oakville, Ontario, Canada L6H 6G4
Tel. #: 905-829-1570, Fax. #: 905-829-8050, Email: vic@ultratech-labs.com, Website: <http://www.ultratech-labs.com>

File #: ICOM-286Q-SAR

February 1, 2012

- All test results contained in this engineering test report are traceable to National Institute of Standards and Technology (NIST)

6.5.1.3. 1/4 helical whip antenna (M/N: FA-SC57U); Belt Clip (M/N: MB-94), Speaker Microphone (M/N: HM-159LA); 469.9 MHz; #03

Test Laboratory: Ultratech Group of Labs

File Name: [ICOM-286Q_FA-SC57U_Body_469.9MHz\(Hf\)_159LA.da52](#)**DUT: ICOM UHF Transceiver; Type: IC-F4031S; Serial: 7200001**

Communication System: CW; Frequency: 469.9 MHz; Duty Cycle: 1:1

Medium parameters used: $f = 470$ MHz; $\sigma = 0.954$ mho/m; $\epsilon_r = 55.983$; $\rho = 1000$ kg/m³

Phantom section: Flat Section

DASY5 Configuration:

- Probe: ES3DV3 - SN3208; ConvF(7, 7, 7); Calibrated: 3/15/2011
- Sensor-Surface: 4mm (Mechanical Surface Detection), Sensor-Surface: 3.4mm (Mechanical Surface Detection)
- Electronics: DAE4 Sn874;
- Phantom: ELI 4.0; Type: QD OVA 001 BB; Serial: 1057
- Measurement SW: DASY52, Version 52.8 (0); SEMCAD X Version 14.6.4 (4989)

Configuration_Body_FA-SC57U_Hf/Body Back, d=0mm, Pin=4W (ES-Probe)/FindMax (11x41x1): Measurement grid: dx=20mm, dy=20mm

Maximum value of SAR (interpolated) = 7.435 mW/g

Configuration_Body_FA-SC57U_Hf/Body Back, d=0mm, Pin=4W (ES-Probe)/Area Scan (61x81x1): Measurement grid: dx=15mm, dy=15mm

Maximum value of SAR (interpolated) = 7.502 mW/g

Configuration_Body_FA-SC57U_Hf/Body Back, d=0mm, Pin=4W (ES-Probe)/Zoom Scan (5x5x7) (7x7x7)/Cube 0:

Measurement grid: dx=5mm, dy=5mm, dz=5mm

Reference Value = 88.351 V/m; Power Drift = -0.02 dB

Peak SAR (extrapolated) = 8.9890

SAR(1 g) = 6.33 mW/g; SAR(10 g) = 4.61 mW/g (SAR corrected for target medium)

Maximum value of SAR (measured) = 6.799 mW/g

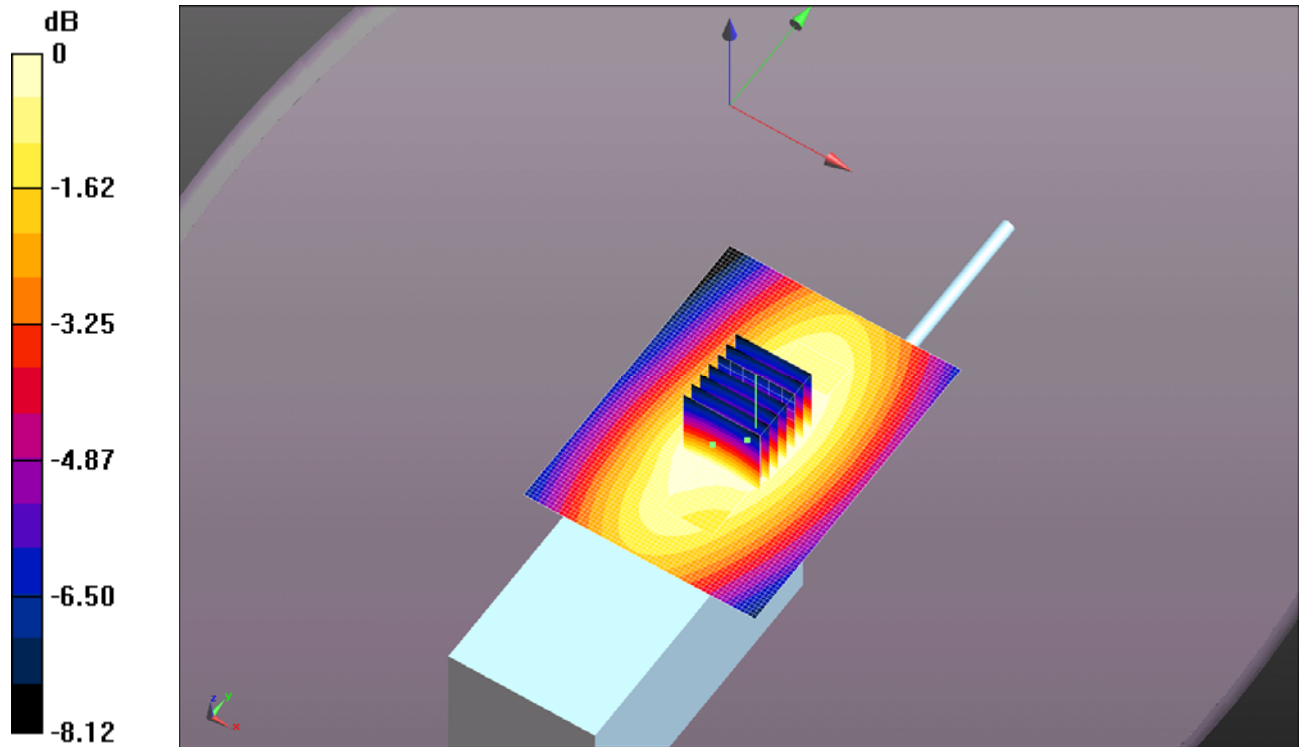

0 dB = 6.800mW/g = 16.65 dB mW/g

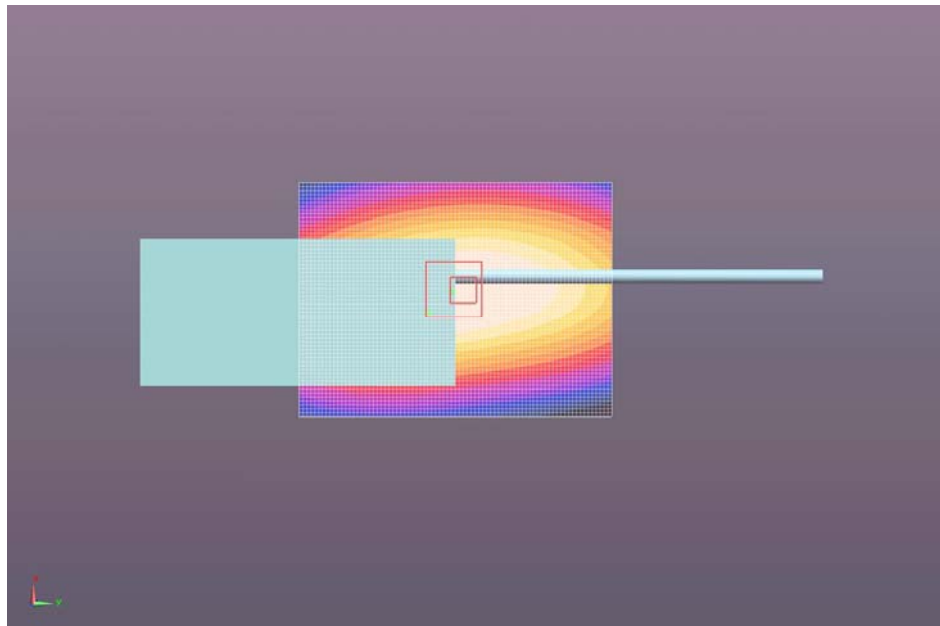

ULTRATECH GROUP OF LABS

3000 Bristol Circle, Oakville, Ontario, Canada L6H 6G4

Tel. #: 905-829-1570, Fax. #: 905-829-8050, Email: vic@ultratech-labs.com, Website: <http://www.ultratech-labs.com>

File #: ICOM-286Q-SAR

February 1, 2012

- All test results contained in this engineering test report are traceable to National Institute of Standards and Technology (NIST)

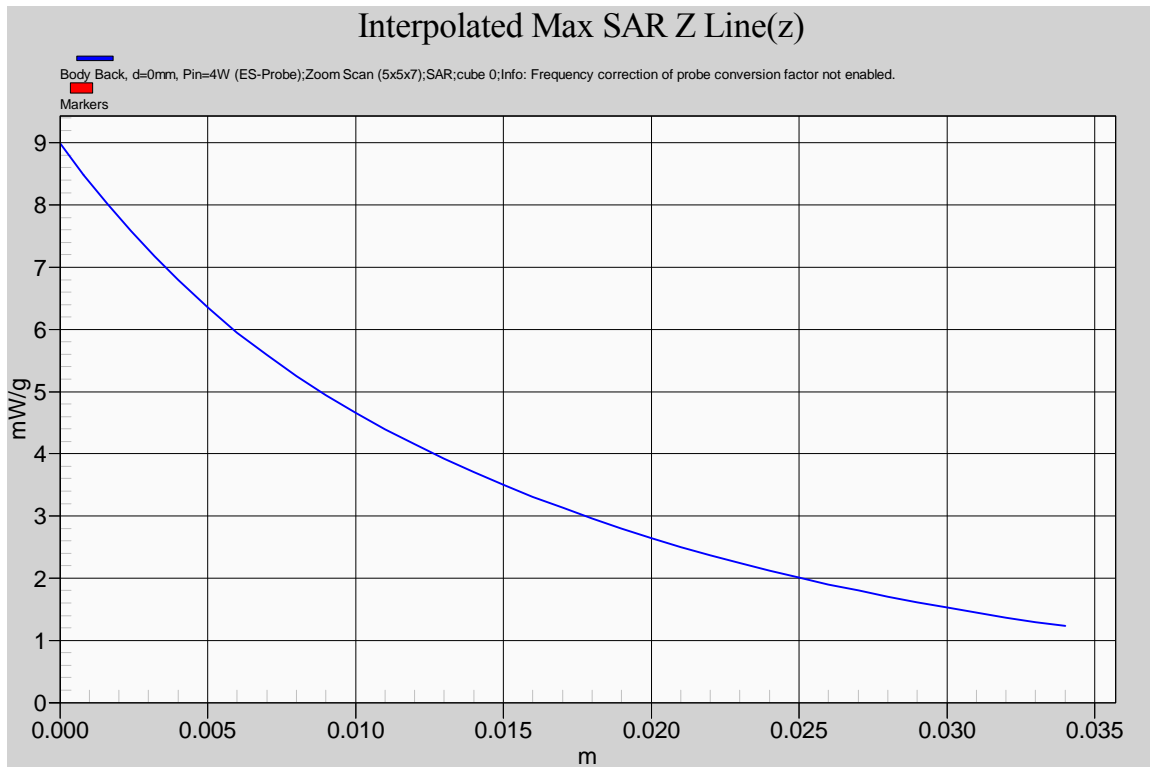

ULTRATECH GROUP OF LABS

3000 Bristol Circle, Oakville, Ontario, Canada L6H 6G4

Tel. #: 905-829-1570, Fax #: 905-829-8050, Email: vic@ultratech-labs.com, Website: <http://www.ultratech-labs.com>

File #: ICOM-286Q-SAR

February 1, 2012

- All test results contained in this engineering test report are traceable to National Institute of Standards and Technology (NIST)

6.5.1.4. 1/4 helical whip antenna (M/N: FA-SC57U); Belt Clip (M/N: MB-94), Speaker Microphone (M/N: HM-166LA); 469.9 MHz; #04

Test Laboratory: Ultratech Group of Labs

File Name: [ICOM-286Q_FA-SC57U_Body_469.9MHz\(Hf\)_166LA.da52](#)**DUT: ICOM UHF Transceiver; Type: IC-F4031S; Serial: 7200001**

Communication System: CW; Frequency: 469.9 MHz; Duty Cycle: 1:1

Medium parameters used: $f = 470$ MHz; $\sigma = 0.954$ mho/m; $\epsilon_r = 55.983$; $\rho = 1000$ kg/m³

Phantom section: Flat Section

DASY5 Configuration:

- Probe: ES3DV3 - SN3208; ConvF(7, 7, 7); Calibrated: 3/15/2011
- Sensor-Surface: 4mm (Mechanical Surface Detection), Sensor-Surface: 3.4mm (Mechanical Surface Detection)
- Electronics: DAE4 Sn874;
- Phantom: ELI 4.0; Type: QD OVA 001 BB; Serial: 1057
- Measurement SW: DASY52, Version 52.8 (0); SEMCAD X Version 14.6.4 (4989)

Configuration_Body_FA-SC57U_Hf/Body Back, d=0mm, Pin=4W (ES-Probe)/FindMax (11x41x1): Measurement grid: dx=20mm, dy=20mm

Maximum value of SAR (interpolated) = 6.921 mW/g

Configuration_Body_FA-SC57U_Hf/Body Back, d=0mm, Pin=4W (ES-Probe)/Area Scan (61x81x1): Measurement grid: dx=15mm, dy=15mm

Maximum value of SAR (interpolated) = 6.777 mW/g

Configuration_Body_FA-SC57U_Hf/Body Back, d=0mm, Pin=4W (ES-Probe)/Zoom Scan (5x5x7) (7x7x7)/Cube 0:

Measurement grid: dx=5mm, dy=5mm, dz=5mm

Reference Value = 85.227 V/m; Power Drift = -0.09 dB

Peak SAR (extrapolated) = 8.2490

SAR(1 g) = 5.9 mW/g; SAR(10 g) = 4.32 mW/g (SAR corrected for target medium)

Maximum value of SAR (measured) = 6.293 mW/g

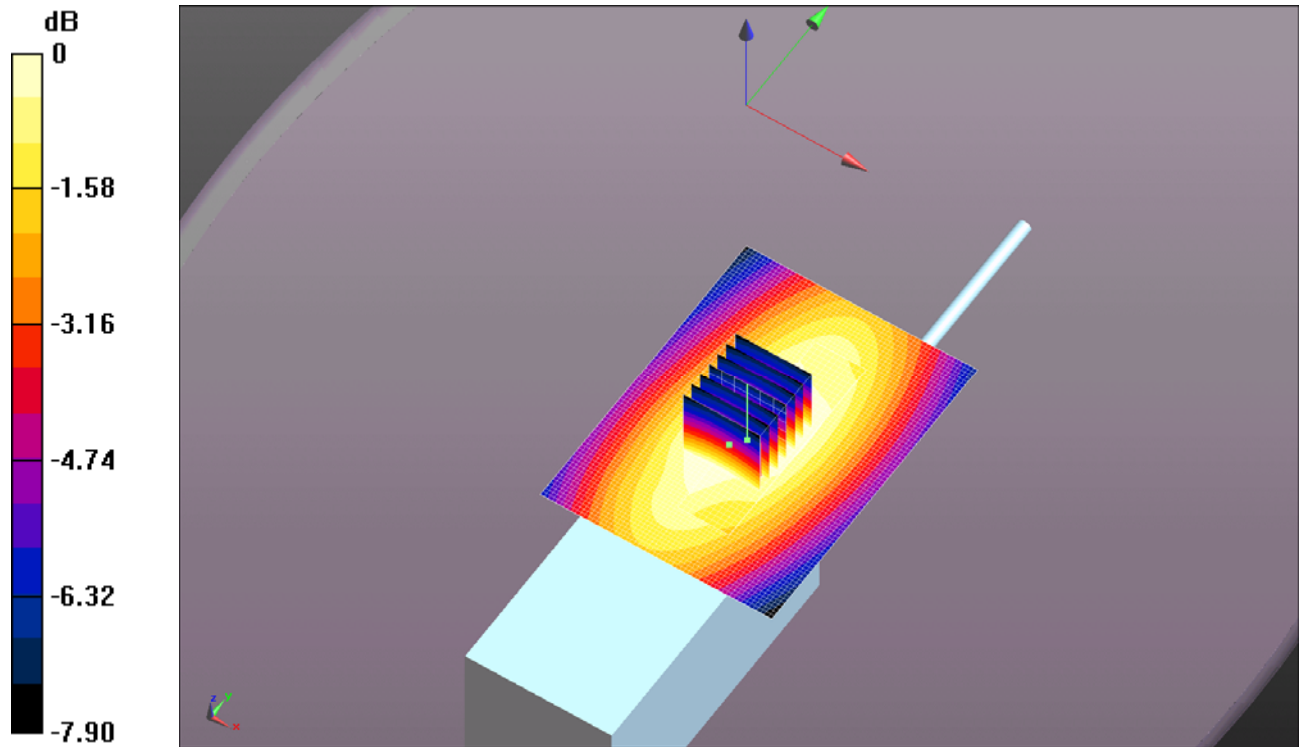

0 dB = 6.290mW/g = 15.97 dB mW/g

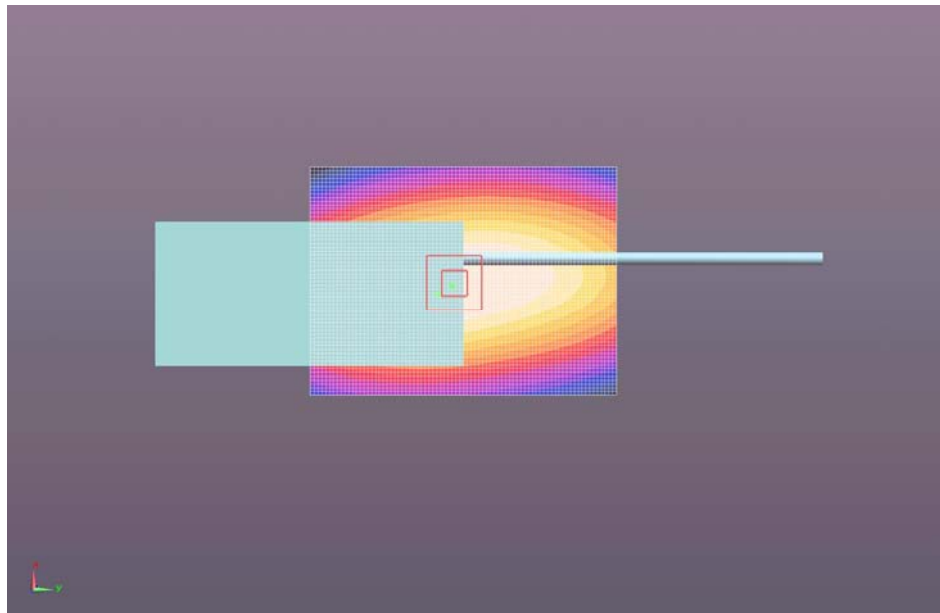

ULTRATECH GROUP OF LABS

3000 Bristol Circle, Oakville, Ontario, Canada L6H 6G4

Tel. #: 905-829-1570, Fax. #: 905-829-8050, Email: vic@ultratech-labs.com, Website: <http://www.ultratech-labs.com>

File #: ICOM-286Q-SAR

February 1, 2012

- All test results contained in this engineering test report are traceable to National Institute of Standards and Technology (NIST)

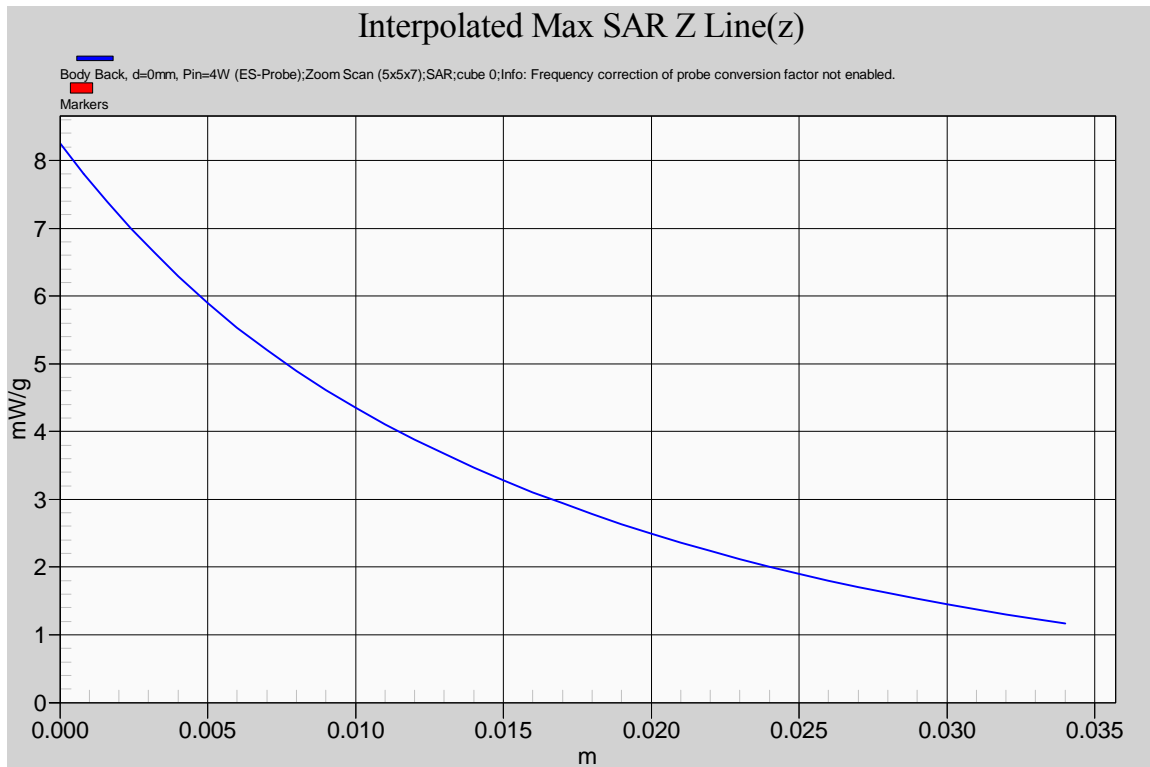

ULTRATECH GROUP OF LABS

3000 Bristol Circle, Oakville, Ontario, Canada L6H 6G4
Tel. #: 905-829-1570, Fax. #: 905-829-8050, Email: vic@ultratech-labs.com, Website: <http://www.ultratech-labs.com>

File #: ICOM-286Q-SAR

February 1, 2012

- All test results contained in this engineering test report are traceable to National Institute of Standards and Technology (NIST)

6.5.1.5. $\frac{1}{4}$ helical whip antenna (M/N: FA-SC57U); Belt Clip (M/N: MB-94), Speaker Microphone (M/N: HM-168LWP); 469.9 MHz; #05

Test Laboratory: Ultratech Group of Labs

File Name: [ICOM-286Q_FA-SC57U_Body_469.9MHz\(Hf\)_168LWP.da52](#)**DUT: ICOM UHF Transceiver; Type: IC-F4031S; Serial: 7200001**

Communication System: CW; Frequency: 469.9 MHz; Duty Cycle: 1:1

Medium parameters used: $f = 470$ MHz; $\sigma = 0.954$ mho/m; $\epsilon_r = 55.983$; $\rho = 1000$ kg/m³

Phantom section: Flat Section

DASY5 Configuration:

- Probe: ES3DV3 - SN3208; ConvF(7, 7, 7); Calibrated: 3/15/2011
- Sensor-Surface: 4mm (Mechanical Surface Detection), Sensor-Surface: 3.4mm (Mechanical Surface Detection)
- Electronics: DAE4 Sn874;
- Phantom: ELI 4.0; Type: QD OVA 001 BB; Serial: 1057
- Measurement SW: DASY52, Version 52.8 (0); SEMCAD X Version 14.6.4 (4989)

Configuration_Body_FA-SC57U_Hf/Body Back, d=0mm, Pin=4W (ES-Probe)/FindMax (11x41x1): Measurement grid: dx=20mm, dy=20mm

Maximum value of SAR (interpolated) = 6.857 mW/g

Configuration_Body_FA-SC57U_Hf/Body Back, d=0mm, Pin=4W (ES-Probe)/Area Scan (61x81x1): Measurement grid: dx=15mm, dy=15mm

Maximum value of SAR (interpolated) = 6.973 mW/g

Configuration_Body_FA-SC57U_Hf/Body Back, d=0mm, Pin=4W (ES-Probe)/Zoom Scan (5x5x7) (7x7x7)/Cube 0:

Measurement grid: dx=5mm, dy=5mm, dz=5mm

Reference Value = 85.021 V/m; Power Drift = -0.15 dB

Peak SAR (extrapolated) = 8.3030

SAR(1 g) = 5.89 mW/g; SAR(10 g) = 4.31 mW/g (SAR corrected for target medium)

Maximum value of SAR (measured) = 6.258 mW/g

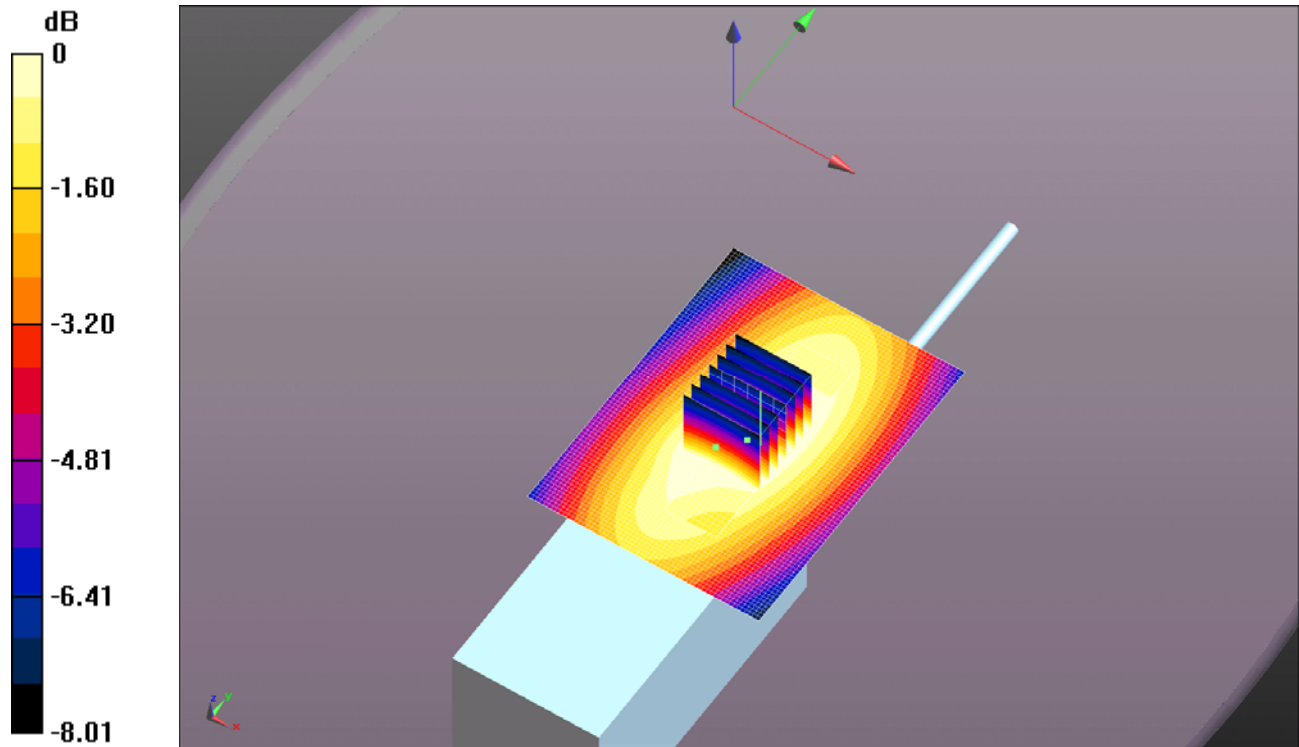

0 dB = 6.260mW/g = 15.93 dB mW/g

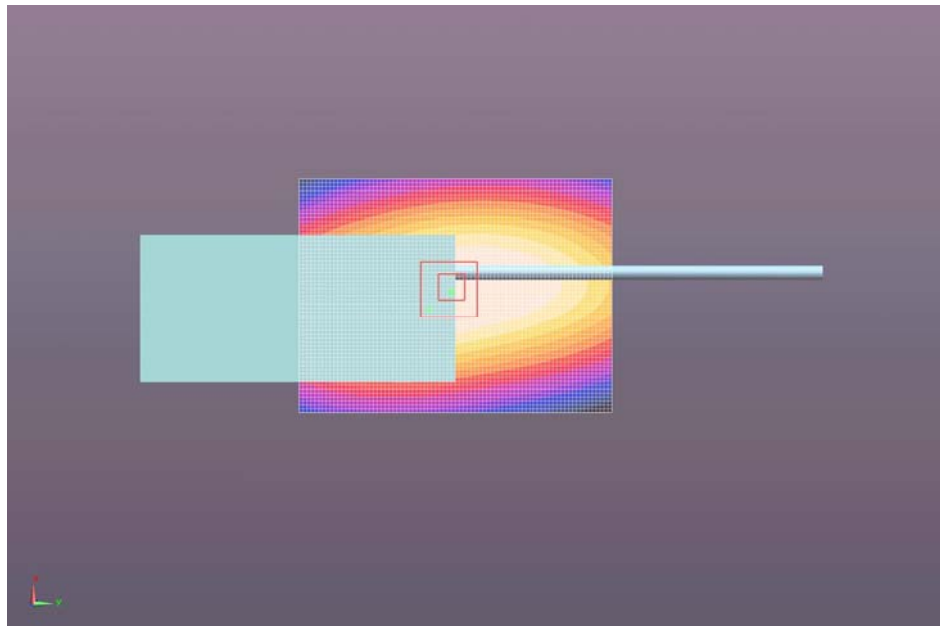

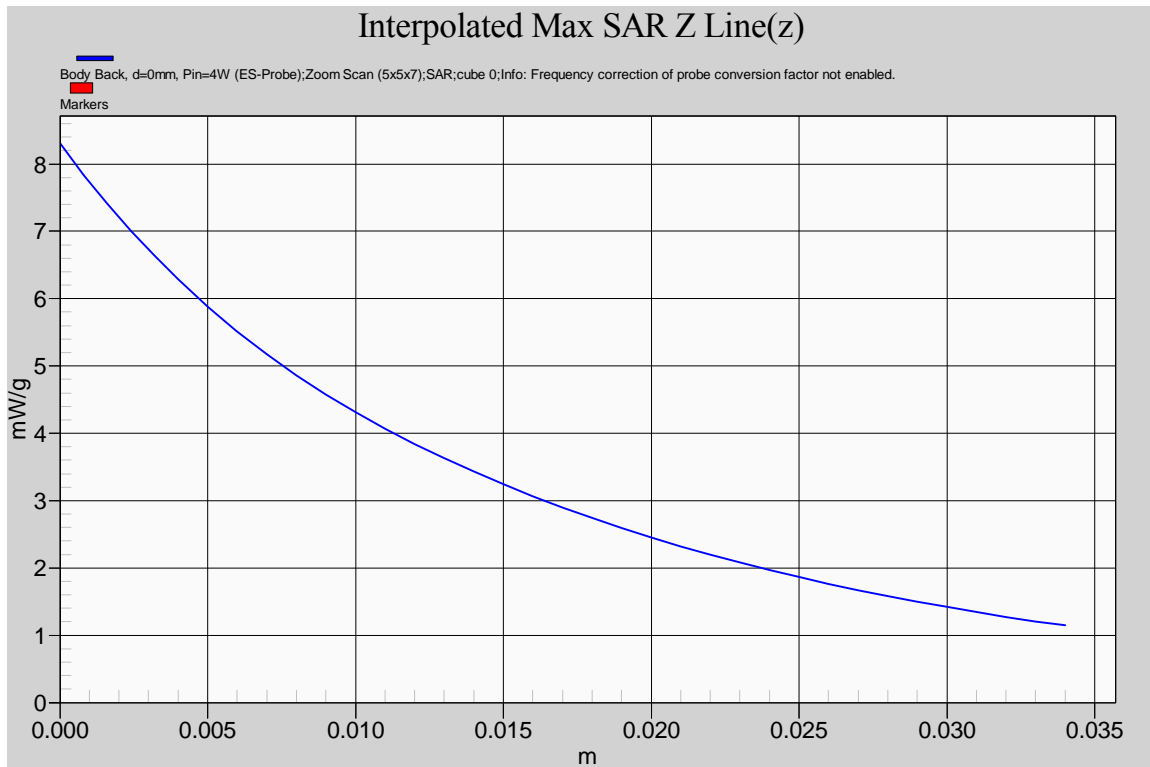

ULTRATECH GROUP OF LABS

3000 Bristol Circle, Oakville, Ontario, Canada L6H 6G4
Tel. #: 905-829-1570, Fax. #: 905-829-8050, Email: vic@ultratech-labs.com, Website: <http://www.ultratech-labs.com>

File #: ICOM-286Q-SAR
February 1, 2012

- All test results contained in this engineering test report are traceable to National Institute of Standards and Technology (NIST)

6.5.2. Head Configuration Result* for Cut Antenna (FA-SC61UC)

#	Configuration	Antenna Position	Frequency [MHz]	Channel	MAX SAR _{1g} [W/Kg]
*	Occupational/Controlled Exposure Category Limit				8.0
6	¼ helical whip cut antenna (M/N: FA-SC61UC, 360~520 MHz, white ring) 50% duty cycle for PTT Antenna Length=165mm	FIX	406.1	Low	3.10
7		FIX	435	Middle	1.23
8		FIX	469.9	High	0.52
9	¼ helical whip antenna (M/N: FA-SC61UC, 360~520 MHz, white ring) 50% duty cycle for PTT Antenna Length=156mm	FIX	406.1	Low	3.03
10		FIX	420	Middle	2.60
11		FIX	469.9	High	0.76
12		FIX	445	Option	-
13	¼ helical whip antenna (M/N: FA-SC61UC, 360~520 MHz, white ring) 50% duty cycle for PTT Antenna Length=148mm	FIX	406.1	Low	2.11
14		FIX	440	Middle	1.92
15		FIX	469.9	High	1.09
16		FIX	420	Option	-
17	¼ helical whip antenna (M/N: FA-SC61UC, 360~520 MHz, white ring) 50% duty cycle for PTT Antenna Length=142mm	FIX	406.1	Low	1.52
18		FIX	430	Middle	2.02
19		FIX	460	High	1.94

*

6.5.2.1. ¼ helical whip cut antenna (M/N: FA-SC61UC), length=165mm; 406.1 MHz; #6

Test Laboratory: Ultratech Group of Labs

File Name: [ICOM-286Q_FA-SC61UC=165mm_Head_406.1MHz\(Lf\).da52](#)**DUT: ICOM UHF Transceiver; Type: IC-F4031S; Serial: 7200001**

Communication System: CW; Frequency: 406.1 MHz; Duty Cycle: 1:1

Medium parameters used (interpolated): $f = 406.1$ MHz; $\sigma = 0.833$ mho/m; $\epsilon_r = 44.368$; $\rho = 1000$ kg/m³

Phantom section: Flat Section

DASY5 Configuration:

- Probe: ES3DV3 - SN3208; ConvF(7.1, 7.1, 7.1); Calibrated: 3/15/2011
- Sensor-Surface: 3.4mm (Mechanical Surface Detection), Sensor-Surface: 4mm (Mechanical Surface Detection)
- Electronics: DAE4 Sn874;
- Phantom: ELI 4.0; Type: QD OVA 001 BB; Serial: 1057
- Measurement SW: DASY52, Version 52.8 (0); SEMCAD X Version 14.6.4 (4989)

Configuration_Head_FA-SC61UC=165mm_LF/Front Face, d=25mm, Pin=4W (ES-Probe)/Area Scan (61x81x1):

Measurement grid: dx=15mm, dy=15mm

[Info: Interpolated medium parameters used for SAR evaluation.](#)

Maximum value of SAR (interpolated) = 7.157 mW/g

Configuration_Head_FA-SC61UC=165mm_LF/Front Face, d=25mm, Pin=4W (ES-Probe)/Zoom Scan (5x5x7)**(7x7x7)/Cube 0:** Measurement grid: dx=5mm, dy=5mm, dz=5mm

Reference Value = 90.223 V/m; Power Drift = -0.19 dB

Peak SAR (extrapolated) = 7.9930

SAR(1 g) = 6.2 mW/g; SAR(10 g) = 4.69 mW/g (SAR corrected for target medium)[Info: Interpolated medium parameters used for SAR evaluation.](#)

Maximum value of SAR (measured) = 6.212 mW/g

Configuration_Head_FA-SC61UC=165mm_LF/Front Face, d=25mm, Pin=4W (ES-Probe)/FindMax (11x41x1):

Measurement grid: dx=20mm, dy=20mm

[Info: Interpolated medium parameters used for SAR evaluation.](#)

Maximum value of SAR (interpolated) = 6.971 mW/g

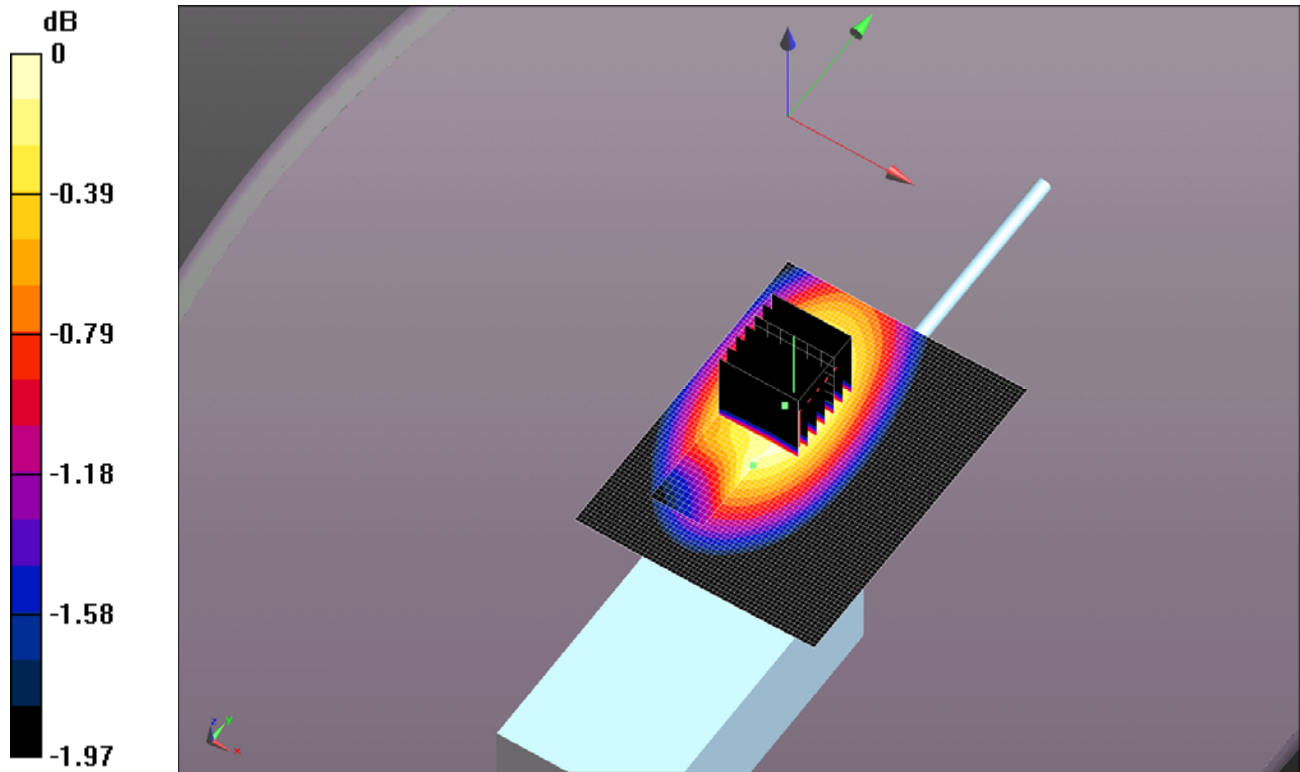

0 dB = 6.970mW/g = 16.86 dB mW/g

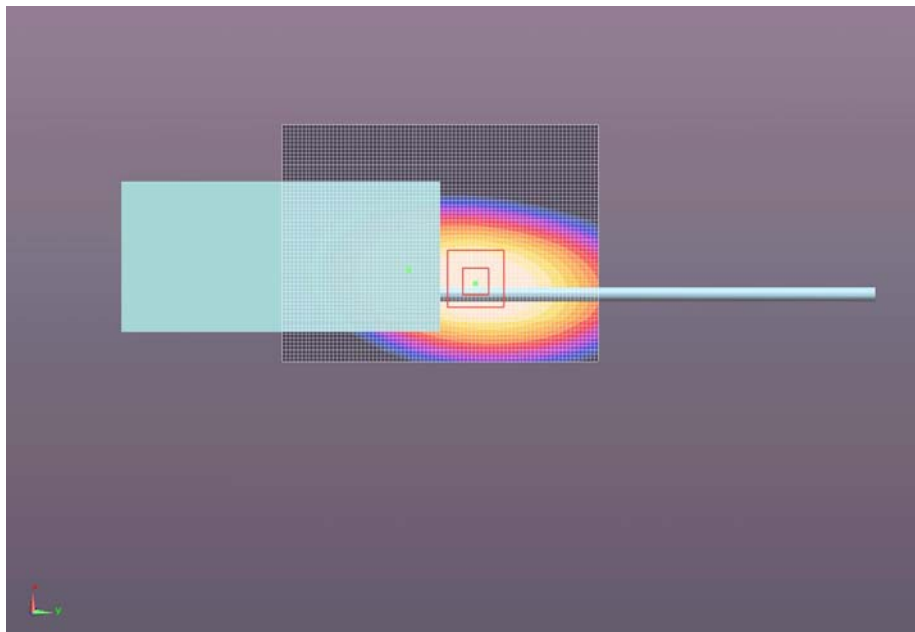

ULTRATECH GROUP OF LABS

3000 Bristol Circle, Oakville, Ontario, Canada L6H 6G4

Tel. #: 905-829-1570, Fax. #: 905-829-8050, Email: vic@ultratech-labs.com, Website: <http://www.ultratech-labs.com>

File #: ICOM-286Q-SAR

February 1, 2012

- All test results contained in this engineering test report are traceable to National Institute of Standards and Technology (NIST)

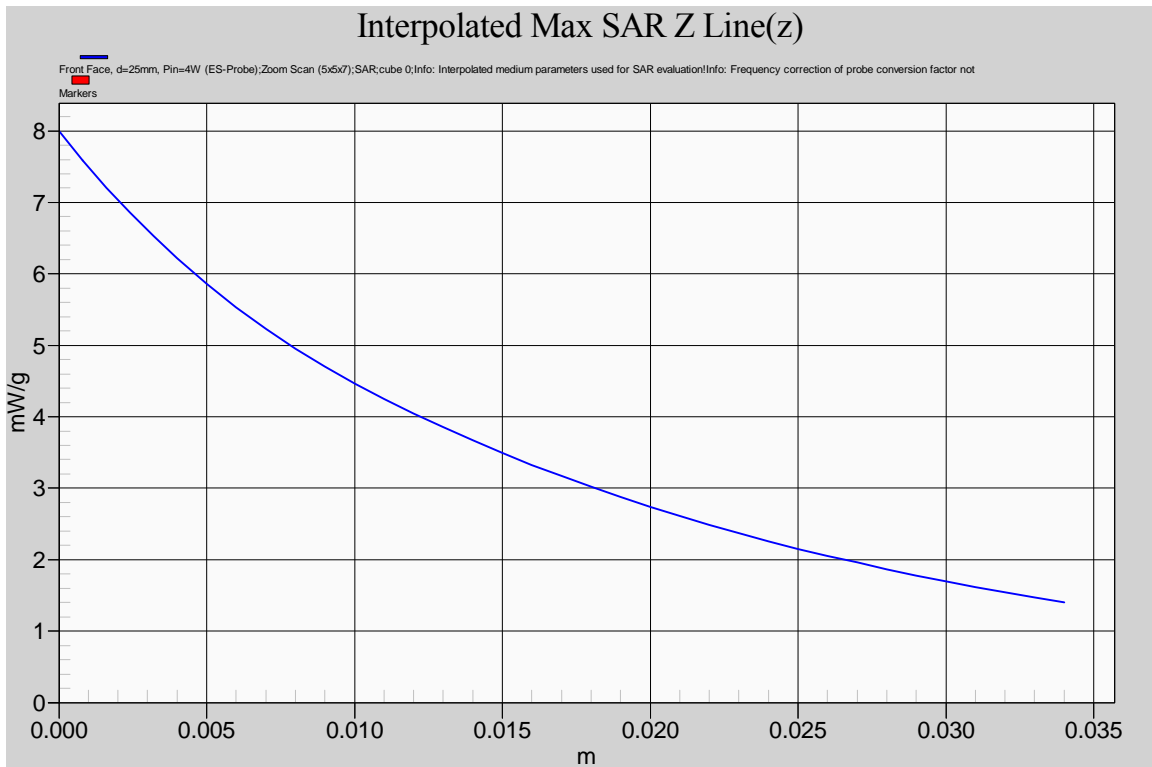

ULTRATECH GROUP OF LABS

3000 Bristol Circle, Oakville, Ontario, Canada L6H 6G4
Tel. #: 905-829-1570, Fax. #: 905-829-8050, Email: vic@ultratech-labs.com, Website: <http://www.ultratech-labs.com>

File #: ICOM-286Q-SAR

February 1, 2012

- All test results contained in this engineering test report are traceable to National Institute of Standards and Technology (NIST)

6.5.2.2. 1/4 helical whip cut antenna (M/N: FA-SC61UC), length=165mm; 435 MHz; #7

Test Laboratory: Ultratech Group of Labs

File Name: [ICOM-286Q_FA-SC61UC=165mm_Head_435MHz\(Mf\).da52](#)**DUT: ICOM UHF Transceiver; Type: IC-F4031S; Serial: 7200001**

Communication System: CW; Frequency: 435 MHz; Duty Cycle: 1:1

Medium parameters used: $f = 435 \text{ MHz}$; $\sigma = 0.86 \text{ mho/m}$; $\epsilon_r = 43.657$; $\rho = 1000 \text{ kg/m}^3$

Phantom section: Flat Section

DASY5 Configuration:

- Probe: ES3DV3 - SN3208; ConvF(7.1, 7.1, 7.1); Calibrated: 3/15/2011
- Sensor-Surface: 3.4mm (Mechanical Surface Detection), Sensor-Surface: 4mm (Mechanical Surface Detection)
- Electronics: DAE4 Sn874;
- Phantom: ELI 4.0; Type: QD OVA 001 BB; Serial: 1057
- Measurement SW: DASY52, Version 52.8 (0); SEMCAD X Version 14.6.4 (4989)

Configuration_Head_FA-SC61UC=165mm_MF/Front Face, d=25mm, Pin=4W (ES-Probe)/Area Scan (61x81x1):

Measurement grid: dx=15mm, dy=15mm

Maximum value of SAR (interpolated) = 2.793 mW/g

Configuration_Head_FA-SC61UC=165mm_MF/Front Face, d=25mm, Pin=4W (ES-Probe)/Zoom Scan (5x5x7)**(7x7x7)/Cube 0:** Measurement grid: dx=5mm, dy=5mm, dz=5mm

Reference Value = 56.530 V/m; Power Drift = -0.10 dB

Peak SAR (extrapolated) = 3.2680

SAR(1 g) = 2.45 mW/g; SAR(10 g) = 1.84 mW/g (SAR corrected for target medium)

Maximum value of SAR (measured) = 2.546 mW/g

Configuration_Head_FA-SC61UC=165mm_MF/Front Face, d=25mm, Pin=4W (ES-Probe)/FindMax (11x41x1):

Measurement grid: dx=20mm, dy=20mm

Maximum value of SAR (interpolated) = 2.893 mW/g

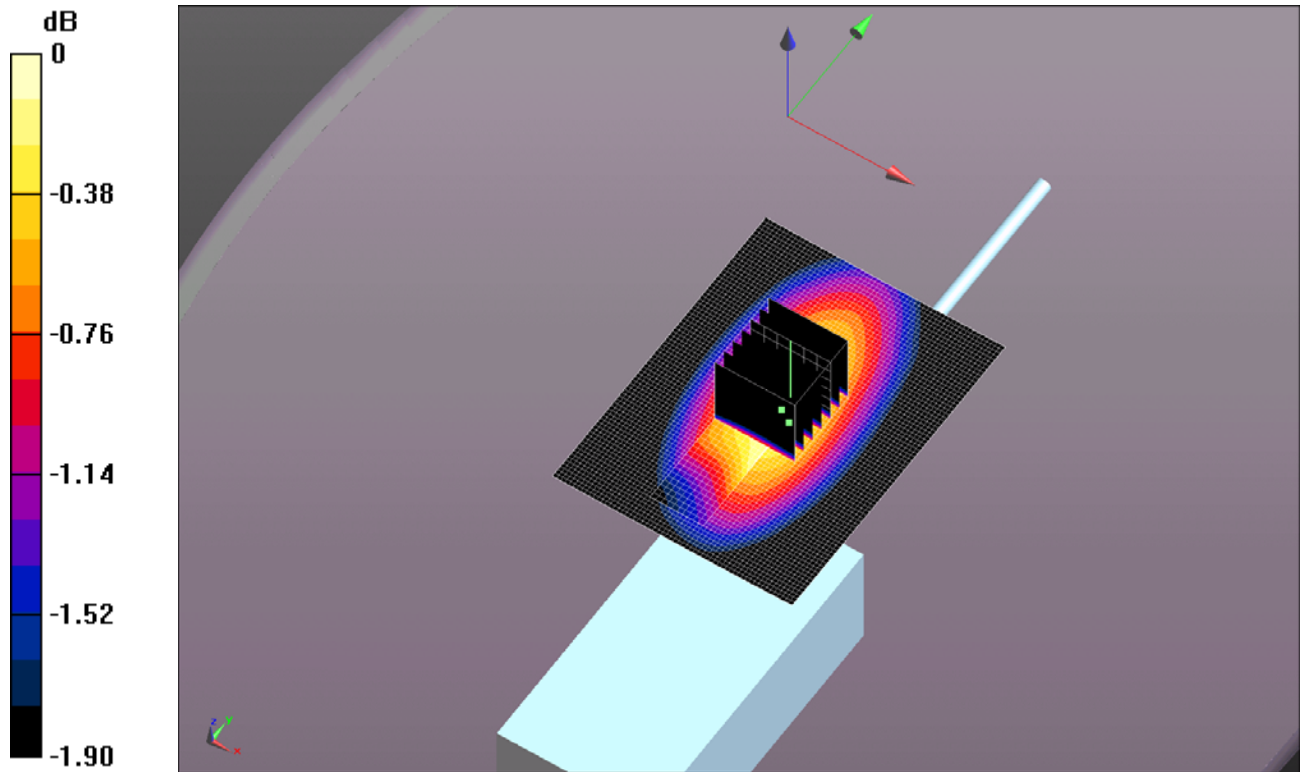

0 dB = 2.890mW/g = 9.22 dB mW/g

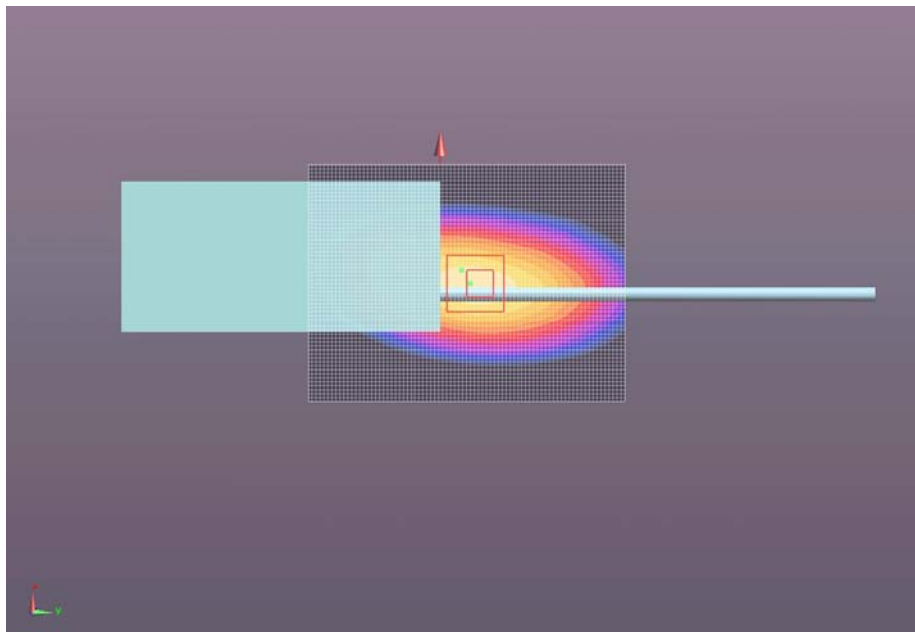

ULTRATECH GROUP OF LABS

3000 Bristol Circle, Oakville, Ontario, Canada L6H 6G4

Tel. #: 905-829-1570, Fax. #: 905-829-8050, Email: vic@ultratech-labs.com, Website: <http://www.ultratech-labs.com>

File #: ICOM-286Q-SAR

February 1, 2012

- All test results contained in this engineering test report are traceable to National Institute of Standards and Technology (NIST)

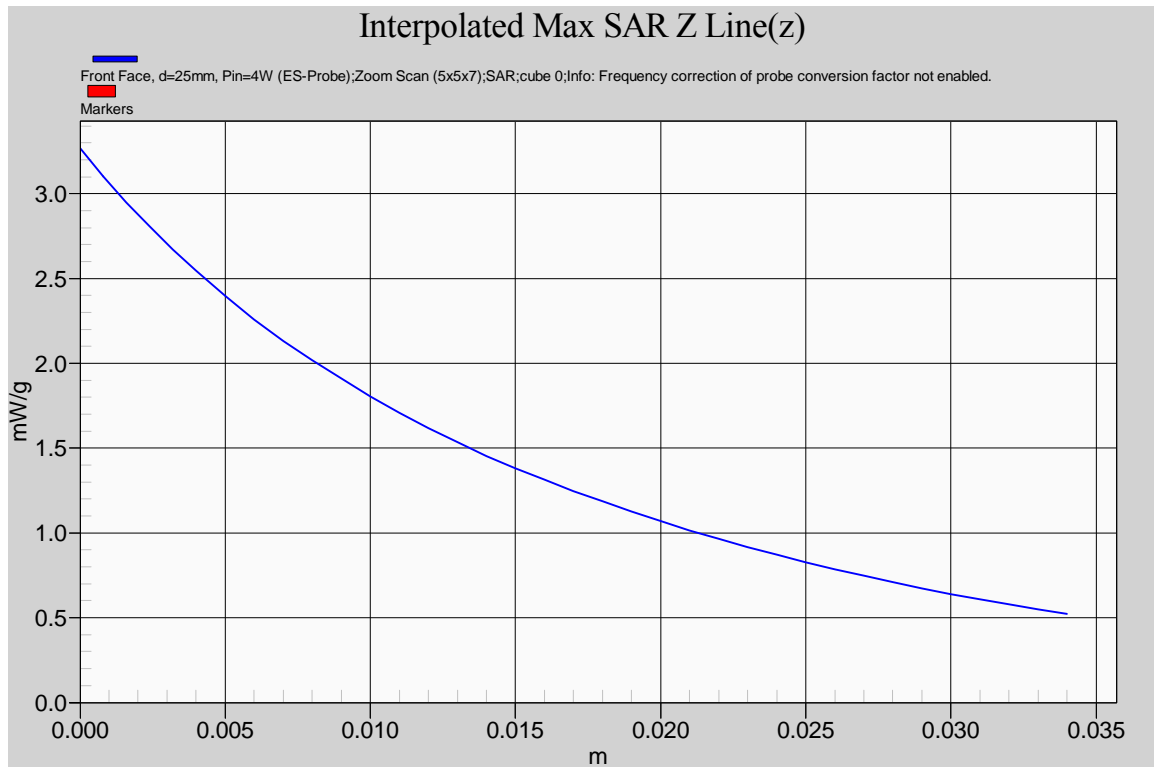

ULTRATECH GROUP OF LABS

3000 Bristol Circle, Oakville, Ontario, Canada L6H 6G4
Tel. #: 905-829-1570, Fax. #: 905-829-8050, Email: vic@ultratech-labs.com, Website: <http://www.ultratech-labs.com>

File #: ICOM-286Q-SAR

February 1, 2012

- All test results contained in this engineering test report are traceable to National Institute of Standards and Technology (NIST)

6.5.2.3. 1/4 helical whip cut antenna (M/N: FA-SC61UC), length=165mm; 469.9 MHz; #8

Test Laboratory: Ultratech Group of Labs

File Name: [ICOM-286Q_FA-SC61UC=165mm_Head_469.9MHz\(Hf\).da52](#)**DUT: ICOM UHF Transceiver; Type: IC-F4031S; Serial: 7200001**

Communication System: CW; Frequency: 469.9 MHz; Duty Cycle: 1:1

Medium parameters used: $f = 470$ MHz; $\sigma = 0.889$ mho/m; $\epsilon_r = 42.931$; $\rho = 1000$ kg/m³

Phantom section: Flat Section

DASY5 Configuration:

- Probe: ES3DV3 - SN3208; ConvF(7.1, 7.1, 7.1); Calibrated: 3/15/2011
- Sensor-Surface: 3.4mm (Mechanical Surface Detection), Sensor-Surface: 4mm (Mechanical Surface Detection)
- Electronics: DAE4 Sn874;
- Phantom: ELI 4.0; Type: QD OVA 001 BB; Serial: 1057
- Measurement SW: DASY52, Version 52.8 (0); SEMCAD X Version 14.6.4 (4989)

Configuration_Head_FA-SC61UC=165mm_HF/Front Face, d=25mm, Pin=4W (ES-Probe)/Area Scan (61x81x1):

Measurement grid: dx=15mm, dy=15mm

Maximum value of SAR (interpolated) = 1.196 mW/g

Configuration_Head_FA-SC61UC=165mm_HF/Front Face, d=25mm, Pin=4W (ES-Probe)/Zoom Scan (5x5x7)**(7x7x7)/Cube 0:** Measurement grid: dx=5mm, dy=5mm, dz=5mm

Reference Value = 36.349 V/m; Power Drift = -0.19 dB

Peak SAR (extrapolated) = 1.4450

SAR(1 g) = 1.04 mW/g; SAR(10 g) = 0.779 mW/g (SAR corrected for target medium)

Maximum value of SAR (measured) = 1.107 mW/g

Configuration_Head_FA-SC61UC=165mm_HF/Front Face, d=25mm, Pin=4W (ES-Probe)/FindMax (11x41x1):

Measurement grid: dx=20mm, dy=20mm

Maximum value of SAR (interpolated) = 1.244 mW/g

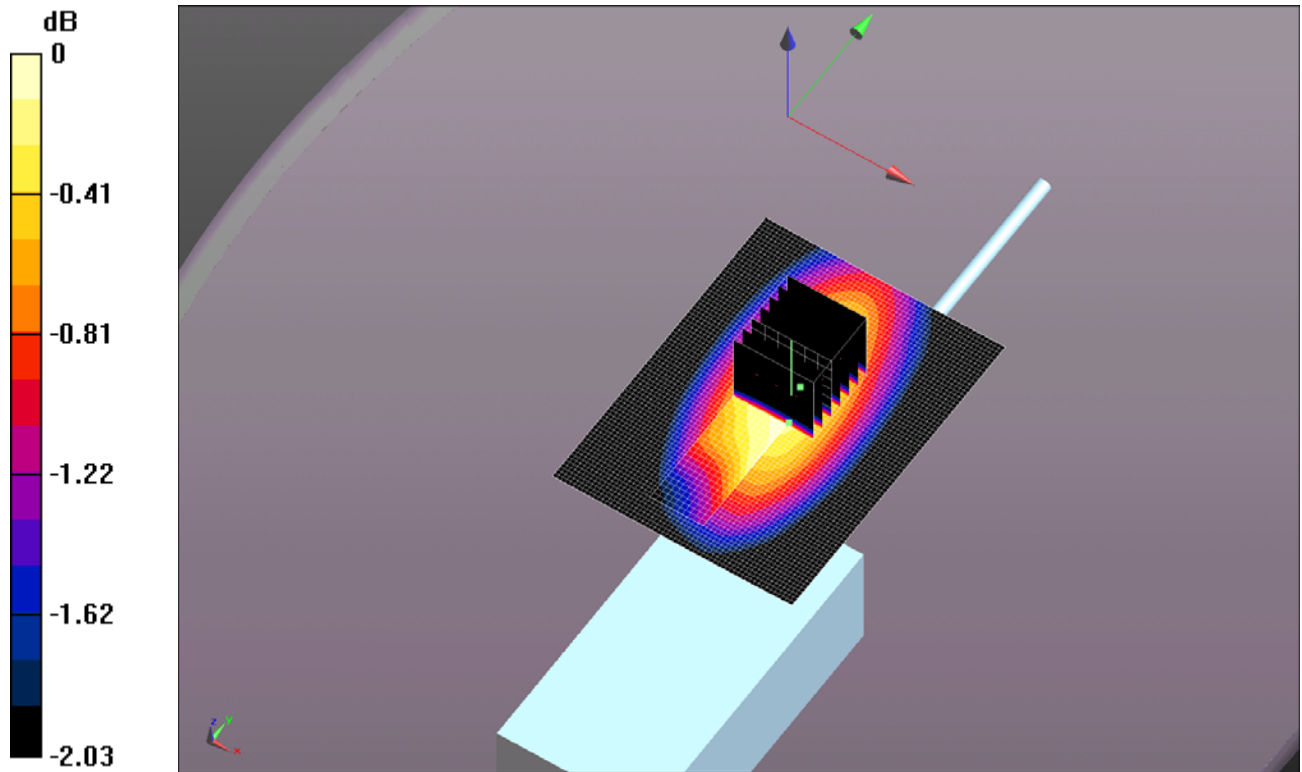

0 dB = 1.240mW/g = 1.87 dB mW/g

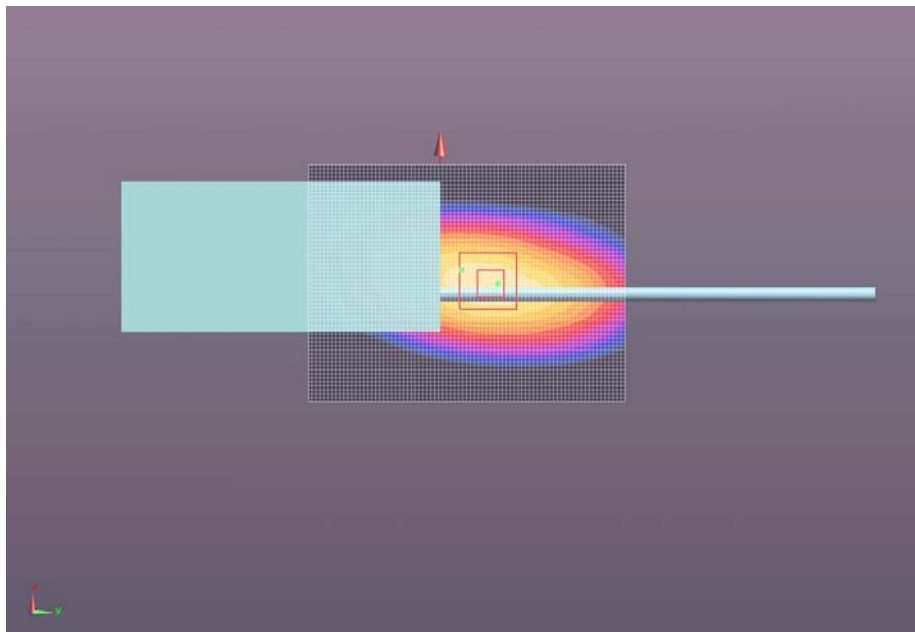

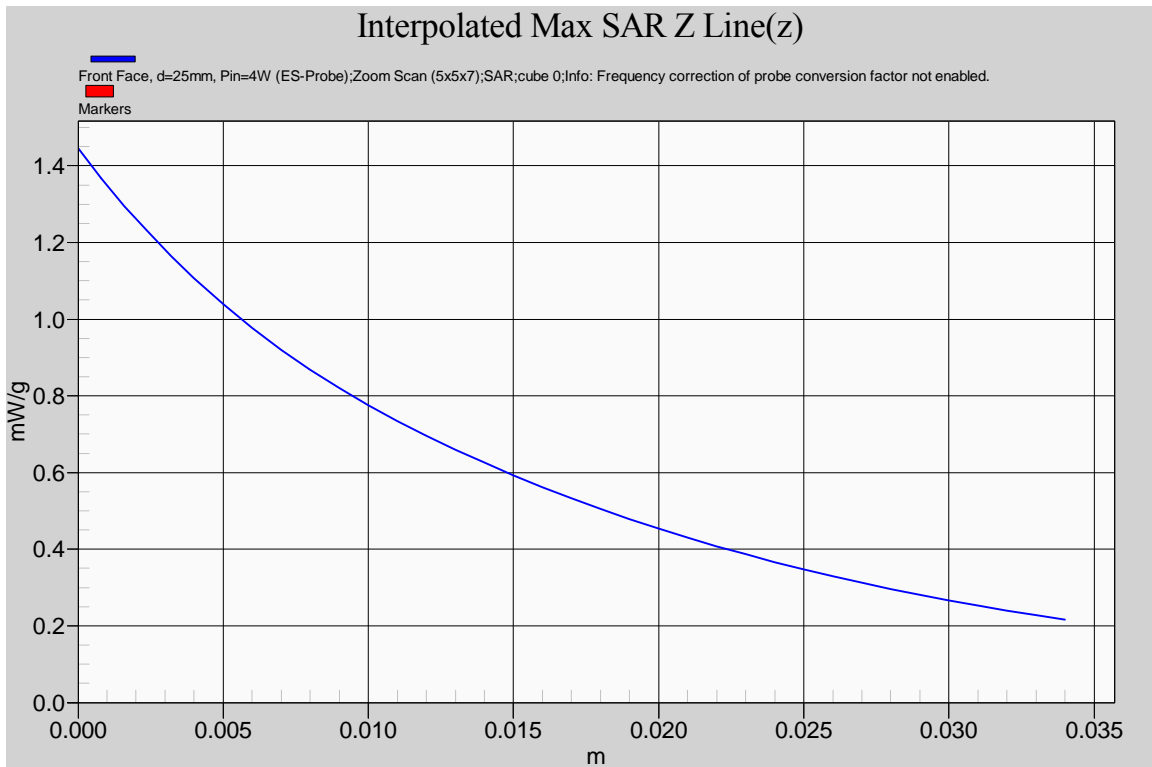

ULTRATECH GROUP OF LABS

3000 Bristol Circle, Oakville, Ontario, Canada L6H 6G4
Tel. #: 905-829-1570, Fax. #: 905-829-8050, Email: vic@ultratech-labs.com, Website: <http://www.ultratech-labs.com>

File #: ICOM-286Q-SAR

February 1, 2012

- All test results contained in this engineering test report are traceable to National Institute of Standards and Technology (NIST)

6.5.2.4. 1/4 helical whip cut antenna (M/N: FA-SC61UC), length=156mm; 406.1 MHz; #9

Test Laboratory: Ultratech Group of Labs

File Name: [ICOM-286Q_FA-SC61UC=156mm_Head_406.1MHz\(Lf\).da52](#)**DUT: ICOM UHF Transceiver; Type: IC-F4031S; Serial: 7200001**

Communication System: CW; Frequency: 406.1 MHz; Duty Cycle: 1:1

Medium parameters used (interpolated): $f = 406.1$ MHz; $\sigma = 0.833$ mho/m; $\epsilon_r = 44.368$; $\rho = 1000$ kg/m³

Phantom section: Flat Section

DASY5 Configuration:

- Probe: ES3DV3 - SN3208; ConvF(7.1, 7.1, 7.1); Calibrated: 3/15/2011
- Sensor-Surface: 3.4mm (Mechanical Surface Detection), Sensor-Surface: 4mm (Mechanical Surface Detection)
- Electronics: DAE4 Sn874;
- Phantom: ELI 4.0; Type: QD OVA 001 BB; Serial: 1057
- Measurement SW: DASY52, Version 52.8 (0); SEMCAD X Version 14.6.4 (4989)

Configuration_Head_FA-SC61UC=156mm_LF/Front Face, d=25mm, Pin=4W (ES-Probe)/Area Scan (61x81x1):

Measurement grid: dx=15mm, dy=15mm

[Info: Interpolated medium parameters used for SAR evaluation.](#)

Maximum value of SAR (interpolated) = 7.062 mW/g

Configuration_Head_FA-SC61UC=156mm_LF/Front Face, d=25mm, Pin=4W (ES-Probe)/Zoom Scan (5x5x7)**(7x7x7)/Cube 0:** Measurement grid: dx=5mm, dy=5mm, dz=5mm

Reference Value = 90.620 V/m; Power Drift = -0.12 dB

Peak SAR (extrapolated) = 7.7780

SAR(1 g) = 6.05 mW/g; SAR(10 g) = 4.57 mW/g (SAR corrected for target medium)[Info: Interpolated medium parameters used for SAR evaluation.](#)

Maximum value of SAR (measured) = 6.081 mW/g

Configuration_Head_FA-SC61UC=156mm_LF/Front Face, d=25mm, Pin=4W (ES-Probe)/FindMax (11x41x1):

Measurement grid: dx=20mm, dy=20mm

[Info: Interpolated medium parameters used for SAR evaluation.](#)

Maximum value of SAR (interpolated) = 7.055 mW/g

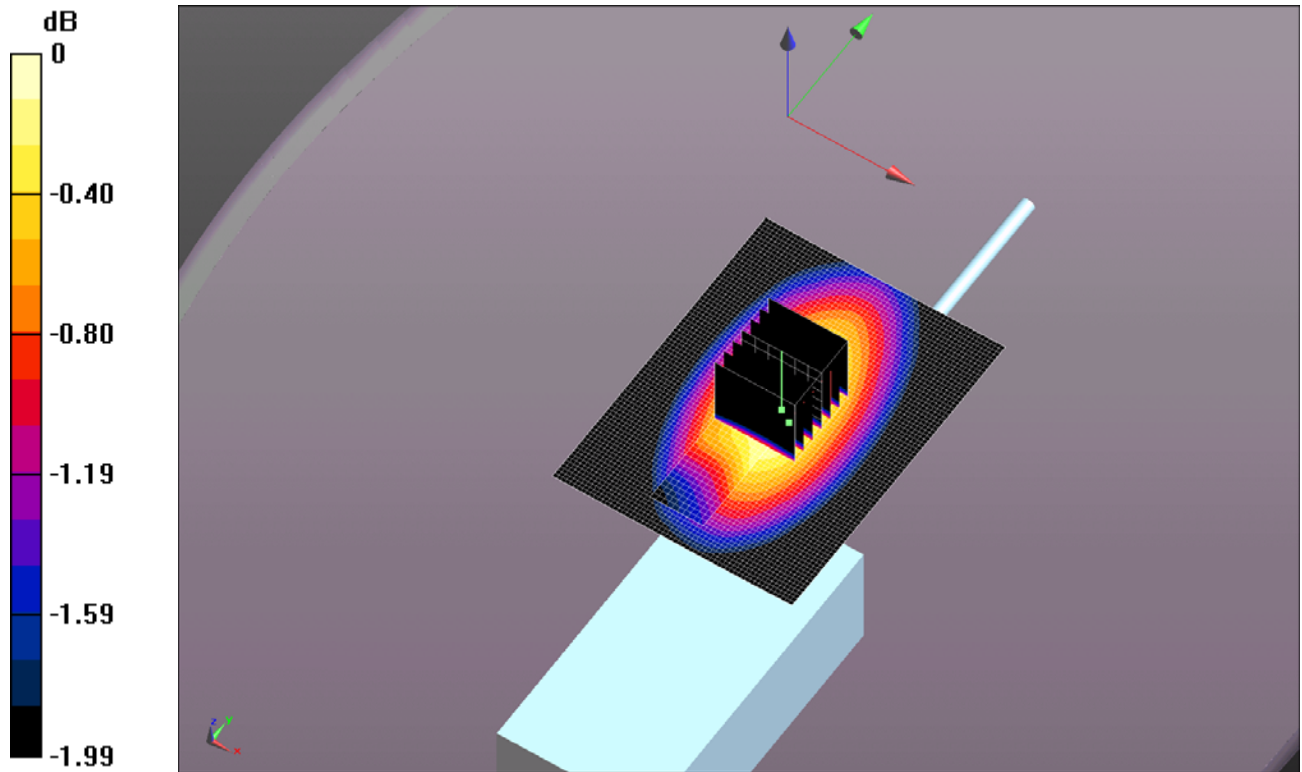

0 dB = 7.050mW/g = 16.96 dB mW/g

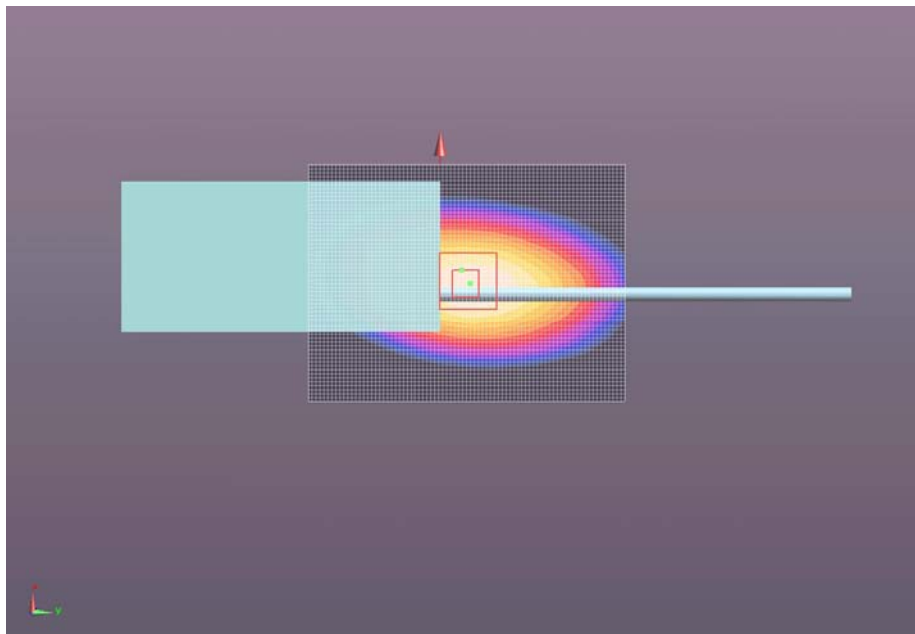

ULTRATECH GROUP OF LABS

3000 Bristol Circle, Oakville, Ontario, Canada L6H 6G4

Tel. #: 905-829-1570, Fax. #: 905-829-8050, Email: vic@ultratech-labs.com, Website: <http://www.ultratech-labs.com>

File #: ICOM-286Q-SAR

February 1, 2012

- All test results contained in this engineering test report are traceable to National Institute of Standards and Technology (NIST)

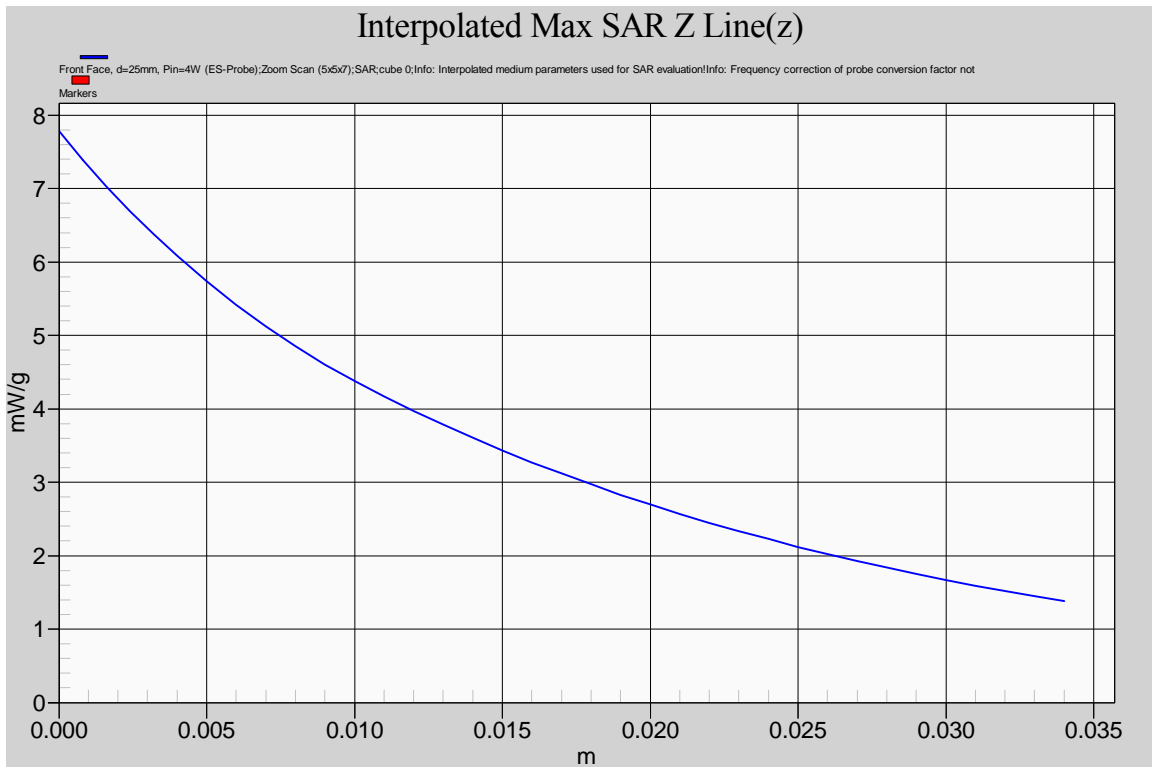

ULTRATECH GROUP OF LABS

3000 Bristol Circle, Oakville, Ontario, Canada L6H 6G4

Tel. #: 905-829-1570, Fax. #: 905-829-8050, Email: vic@ultratech-labs.com, Website: <http://www.ultratech-labs.com>

File #: ICOM-286Q-SAR

February 1, 2012

- All test results contained in this engineering test report are traceable to National Institute of Standards and Technology (NIST)

6.5.2.5. 1/4 helical whip cut antenna (M/N: FA-SC61UC), length=156mm; 420 MHz; #10

Test Laboratory: Ultratech Group of Labs

File Name: [ICOM-286Q_FA-SC61UC=156mm_Head_420MHz\(Mf\).da52](#)**DUT: ICOM UHF Transceiver; Type: IC-F4031S; Serial: 7200001**

Communication System: CW; Frequency: 420 MHz; Duty Cycle: 1:1

Medium parameters used: $f = 420$ MHz; $\sigma = 0.848$ mho/m; $\epsilon_r = 44.005$; $\rho = 1000$ kg/m³

Phantom section: Flat Section

DASY5 Configuration:

- Probe: ES3DV3 - SN3208; ConvF(7.1, 7.1, 7.1); Calibrated: 3/15/2011
- Sensor-Surface: 3.4mm (Mechanical Surface Detection), Sensor-Surface: 4mm (Mechanical Surface Detection)
- Electronics: DAE4 Sn874;
- Phantom: ELI 4.0; Type: QD OVA 001 BB; Serial: 1057
- Measurement SW: DASY52, Version 52.8 (0); SEMCAD X Version 14.6.4 (4989)

Configuration_Head_FA-SC61UC=156mm_MF/Front Face, d=25mm, Pin=4W (ES-Probe)/Area Scan (61x81x1):

Measurement grid: dx=15mm, dy=15mm

Maximum value of SAR (interpolated) = 6.086 mW/g

Configuration_Head_FA-SC61UC=156mm_MF/Front Face, d=25mm, Pin=4W (ES-Probe)/Zoom Scan (5x5x7)**(7x7x7)/Cube 0:** Measurement grid: dx=5mm, dy=5mm, dz=5mm

Reference Value = 83.683 V/m; Power Drift = -0.20 dB

Peak SAR (extrapolated) = 6.8100

SAR(1 g) = 5.19 mW/g; SAR(10 g) = 3.94 mW/g (SAR corrected for target medium)

Maximum value of SAR (measured) = 5.292 mW/g

Configuration_Head_FA-SC61UC=156mm_MF/Front Face, d=25mm, Pin=4W (ES-Probe)/FindMax (11x41x1):

Measurement grid: dx=20mm, dy=20mm

Maximum value of SAR (interpolated) = 5.828 mW/g

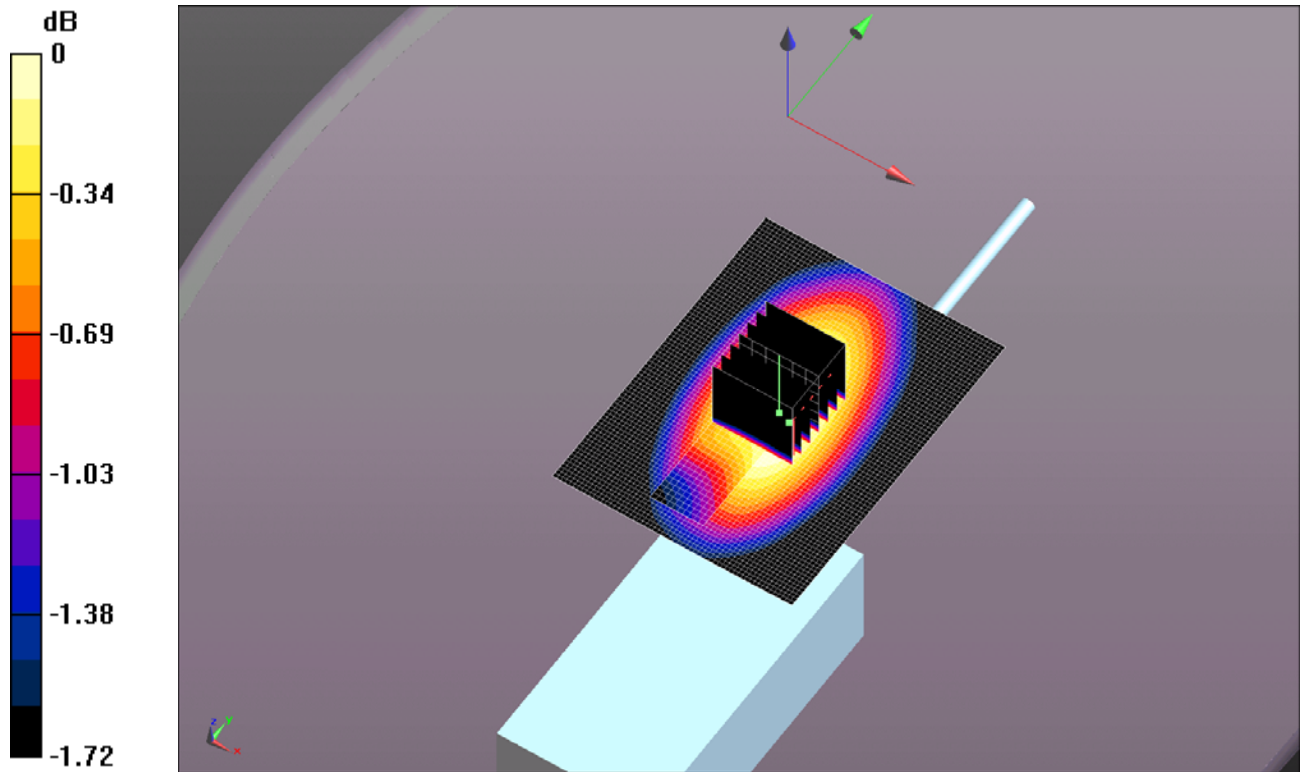

0 dB = 5.830mW/g = 15.31 dB mW/g

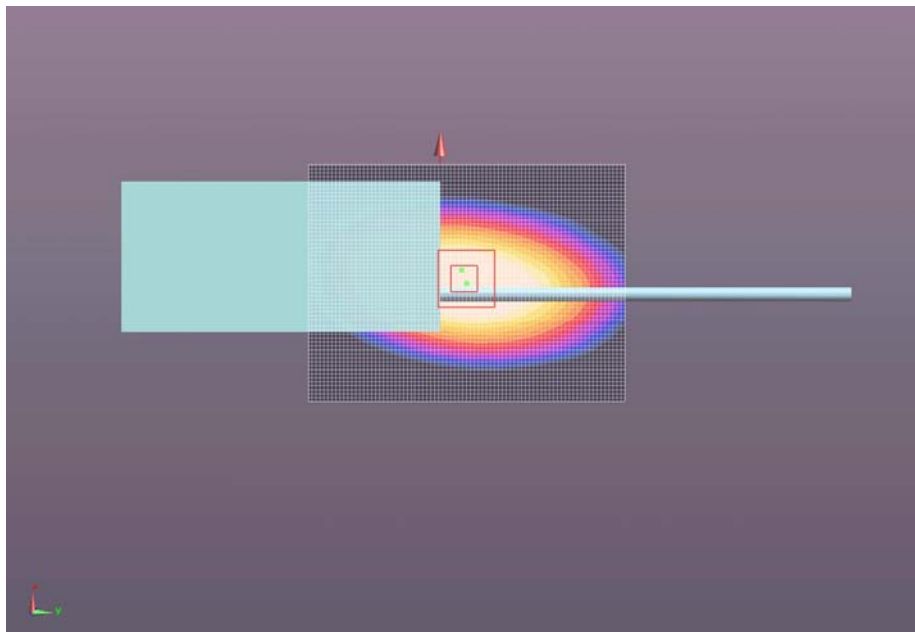

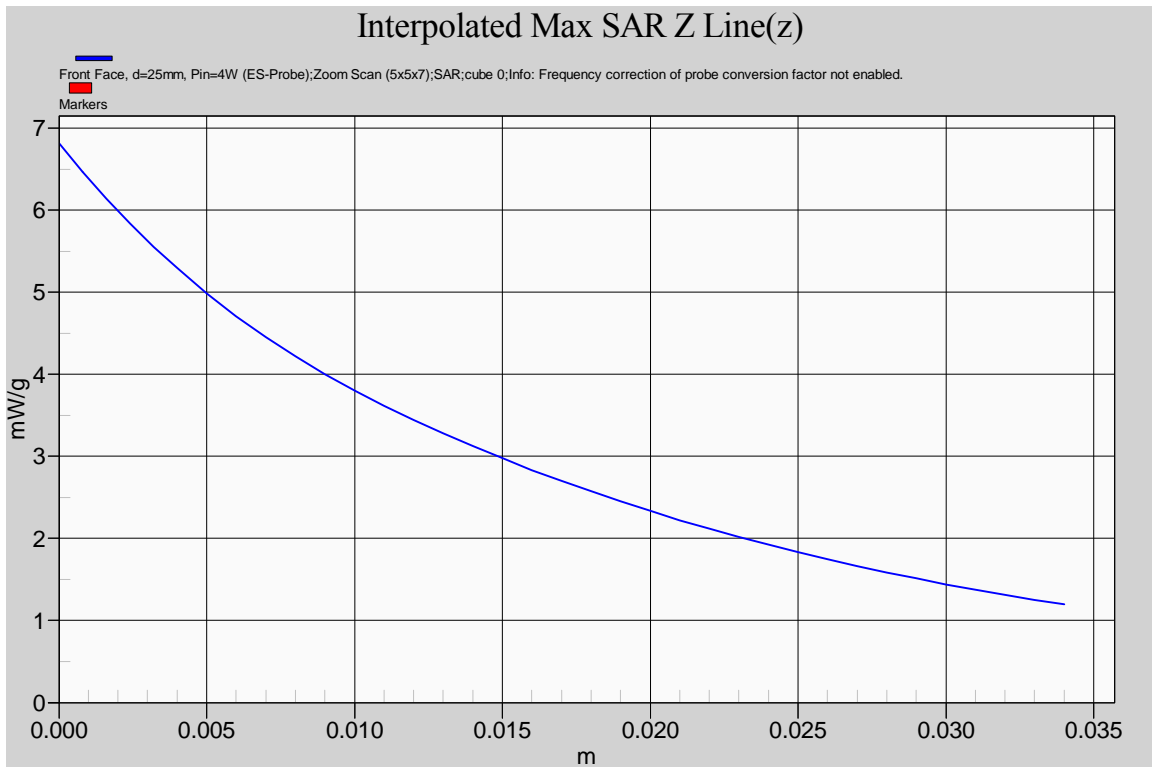

ULTRATECH GROUP OF LABS

3000 Bristol Circle, Oakville, Ontario, Canada L6H 6G4

Tel. #: 905-829-1570, Fax. #: 905-829-8050, Email: vic@ultratech-labs.com, Website: <http://www.ultratech-labs.com>

File #: ICOM-286Q-SAR

February 1, 2012

- All test results contained in this engineering test report are traceable to National Institute of Standards and Technology (NIST)

6.5.2.6. 1/4 helical whip cut antenna (M/N: FA-SC61UC), length=156mm; 469.9 MHz; #11

Test Laboratory: Ultratech Group of Labs

File Name: [ICOM-286Q_FA-SC61UC=156mm_Head_469.9MHz\(Hf\).da52](#)**DUT: ICOM UHF Transceiver; Type: IC-F4031S; Serial: 7200001**

Communication System: CW; Frequency: 469.9 MHz; Duty Cycle: 1:1

Medium parameters used: $f = 470$ MHz; $\sigma = 0.889$ mho/m; $\epsilon_r = 42.931$; $\rho = 1000$ kg/m³

Phantom section: Flat Section

DASY5 Configuration:

- Probe: ES3DV3 - SN3208; ConvF(7.1, 7.1, 7.1); Calibrated: 3/15/2011
- Sensor-Surface: 3.4mm (Mechanical Surface Detection), Sensor-Surface: 4mm (Mechanical Surface Detection)
- Electronics: DAE4 Sn874;
- Phantom: ELI 4.0; Type: QD OVA 001 BB; Serial: 1057
- Measurement SW: DASY52, Version 52.8 (0); SEMCAD X Version 14.6.4 (4989)

Configuration_Head_FA-SC61UC=156mm_HF/Front Face, d=25mm, Pin=4W (ES-Probe)/Area Scan (61x81x1):

Measurement grid: dx=15mm, dy=15mm

Maximum value of SAR (interpolated) = 1.786 mW/g

Configuration_Head_FA-SC61UC=156mm_HF/Front Face, d=25mm, Pin=4W (ES-Probe)/Zoom Scan (5x5x7)**(7x7x7)/Cube 0:** Measurement grid: dx=5mm, dy=5mm, dz=5mm

Reference Value = 44.181 V/m; Power Drift = -0.13 dB

Peak SAR (extrapolated) = 2.1090

SAR(1 g) = 1.51 mW/g; SAR(10 g) = 1.13 mW/g (SAR corrected for target medium)

Maximum value of SAR (measured) = 1.616 mW/g

Configuration_Head_FA-SC61UC=156mm_HF/Front Face, d=25mm, Pin=4W (ES-Probe)/FindMax (11x41x1):

Measurement grid: dx=20mm, dy=20mm

Maximum value of SAR (interpolated) = 1.810 mW/g

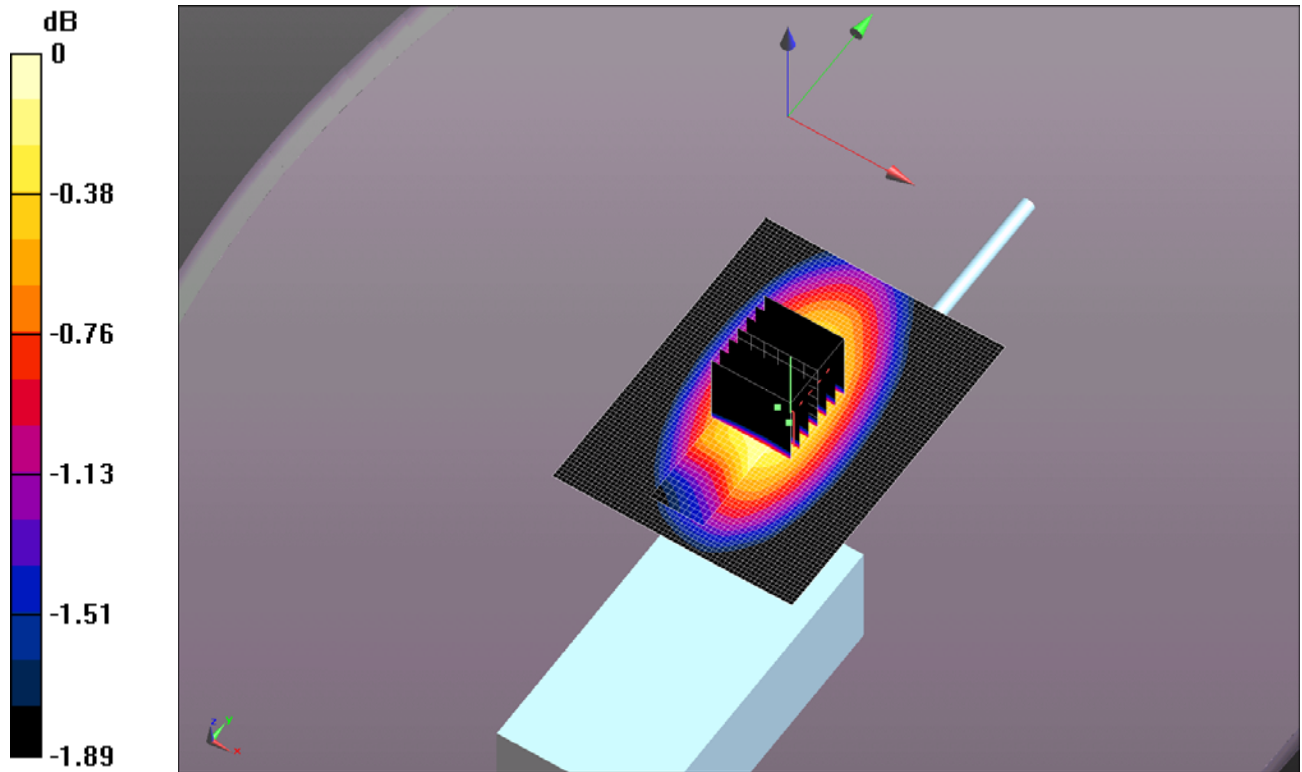

0 dB = 1.810mW/g = 5.15 dB mW/g

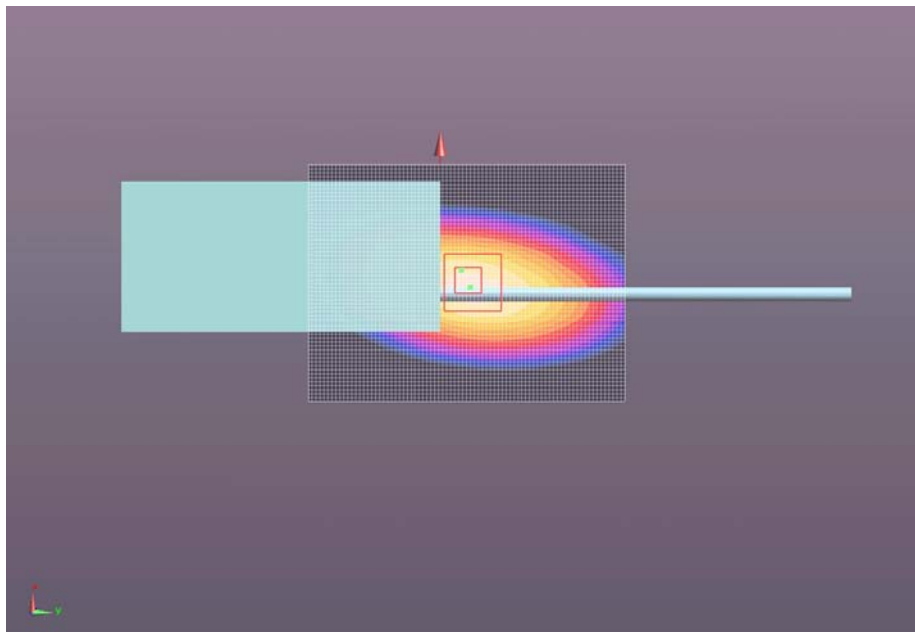

ULTRATECH GROUP OF LABS

3000 Bristol Circle, Oakville, Ontario, Canada L6H 6G4

Tel. #: 905-829-1570, Fax. #: 905-829-8050, Email: vic@ultratech-labs.com, Website: <http://www.ultratech-labs.com>

File #: ICOM-286Q-SAR

February 1, 2012

- All test results contained in this engineering test report are traceable to National Institute of Standards and Technology (NIST)

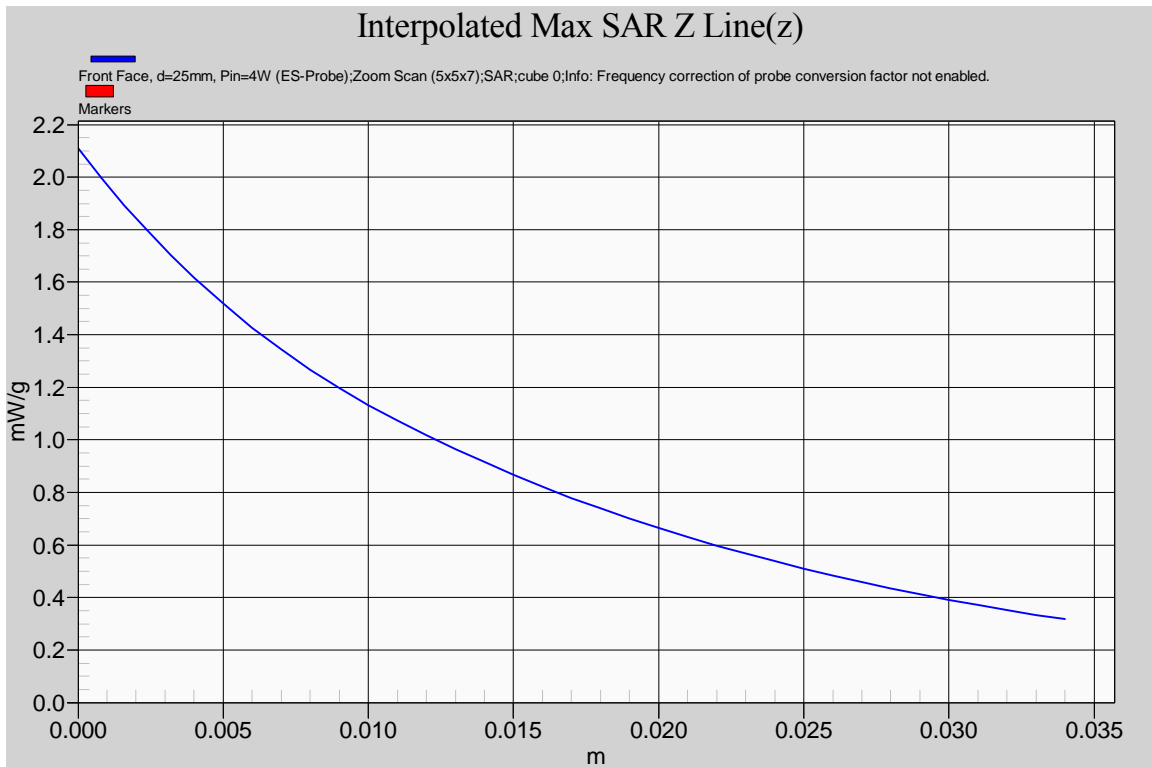

ULTRATECH GROUP OF LABS

3000 Bristol Circle, Oakville, Ontario, Canada L6H 6G4

Tel. #: 905-829-1570, Fax. #: 905-829-8050, Email: vic@ultratech-labs.com, Website: <http://www.ultratech-labs.com>

File #: ICOM-286Q-SAR

February 1, 2012

- All test results contained in this engineering test report are traceable to National Institute of Standards and Technology (NIST)

6.5.2.7. 1/4 helical whip cut antenna (M/N: FA-SC61UC), length=148mm; 406.1 MHz; #13

Test Laboratory: Ultratech Group of Labs

File Name: [ICOM-286Q_FA-SC61UC=148mm_Head_406.1MHz\(Lf\).da52](#)**DUT: ICOM UHF Transceiver; Type: IC-F4031S; Serial: 7200001**

Communication System: CW; Frequency: 406.1 MHz; Duty Cycle: 1:1

Medium parameters used (interpolated): $f = 406.1$ MHz; $\sigma = 0.833$ mho/m; $\epsilon_r = 44.368$; $\rho = 1000$ kg/m³

Phantom section: Flat Section

DASY5 Configuration:

- Probe: ES3DV3 - SN3208; ConvF(7.1, 7.1, 7.1); Calibrated: 3/15/2011
- Sensor-Surface: 3.4mm (Mechanical Surface Detection), Sensor-Surface: 4mm (Mechanical Surface Detection)
- Electronics: DAE4 Sn874;
- Phantom: ELI 4.0; Type: QD OVA 001 BB; Serial: 1057
- Measurement SW: DASY52, Version 52.8 (0); SEMCAD X Version 14.6.4 (4989)

Configuration_Head_FA-SC61UC=148mm_LF/Front Face, d=25mm, Pin=4W (ES-Probe)/Area Scan (61x81x1):

Measurement grid: dx=15mm, dy=15mm

[Info: Interpolated medium parameters used for SAR evaluation.](#)

Maximum value of SAR (interpolated) = 4.688 mW/g

Configuration_Head_FA-SC61UC=148mm_LF/Front Face, d=25mm, Pin=4W (ES-Probe)/Zoom Scan (5x5x7)**(7x7x7)/Cube 0:** Measurement grid: dx=5mm, dy=5mm, dz=5mm

Reference Value = 74.883 V/m; Power Drift = -0.13 dB

Peak SAR (extrapolated) = 5.4370

SAR(1 g) = 4.22 mW/g; SAR(10 g) = 3.18 mW/g (SAR corrected for target medium)[Info: Interpolated medium parameters used for SAR evaluation.](#)

Maximum value of SAR (measured) = 4.237 mW/g

Configuration_Head_FA-SC61UC=148mm_LF/Front Face, d=25mm, Pin=4W (ES-Probe)/FindMax (11x41x1):

Measurement grid: dx=20mm, dy=20mm

[Info: Interpolated medium parameters used for SAR evaluation.](#)

Maximum value of SAR (interpolated) = 4.830 mW/g

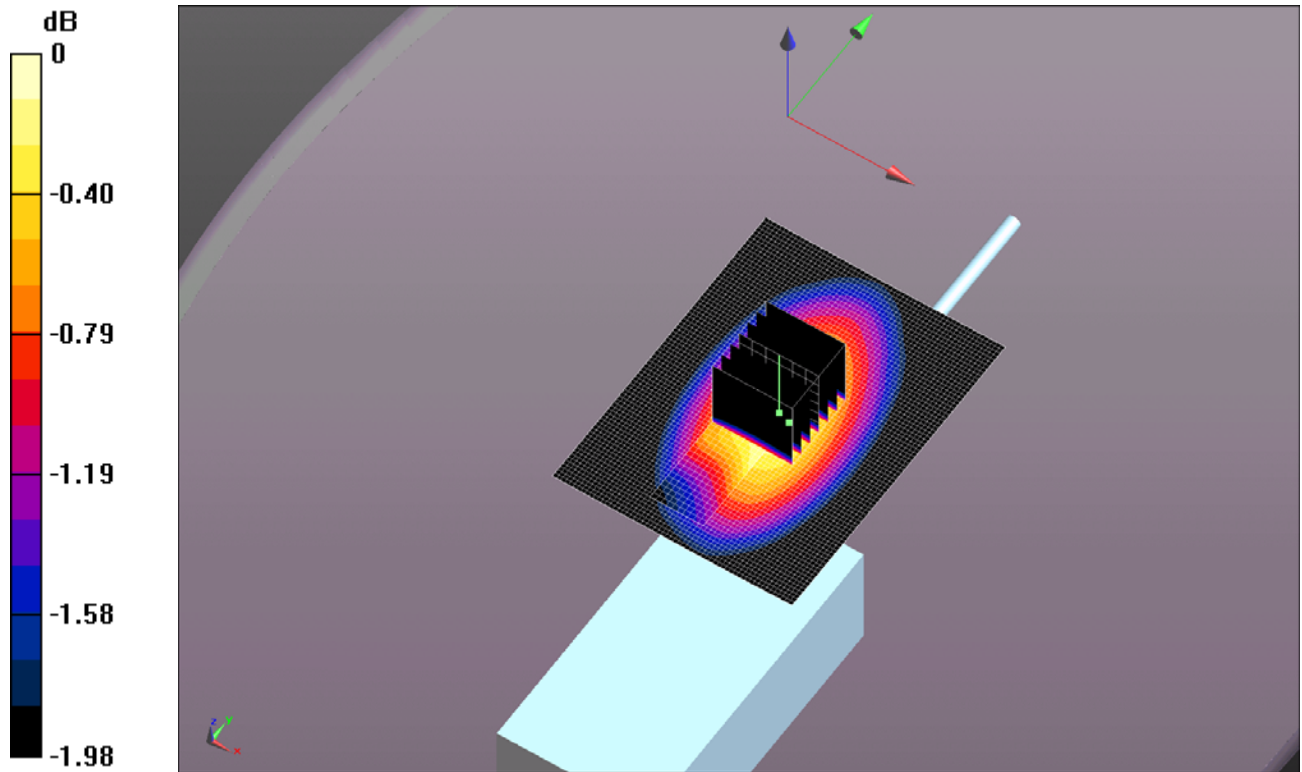

0 dB = 4.830mW/g = 13.68 dB mW/g

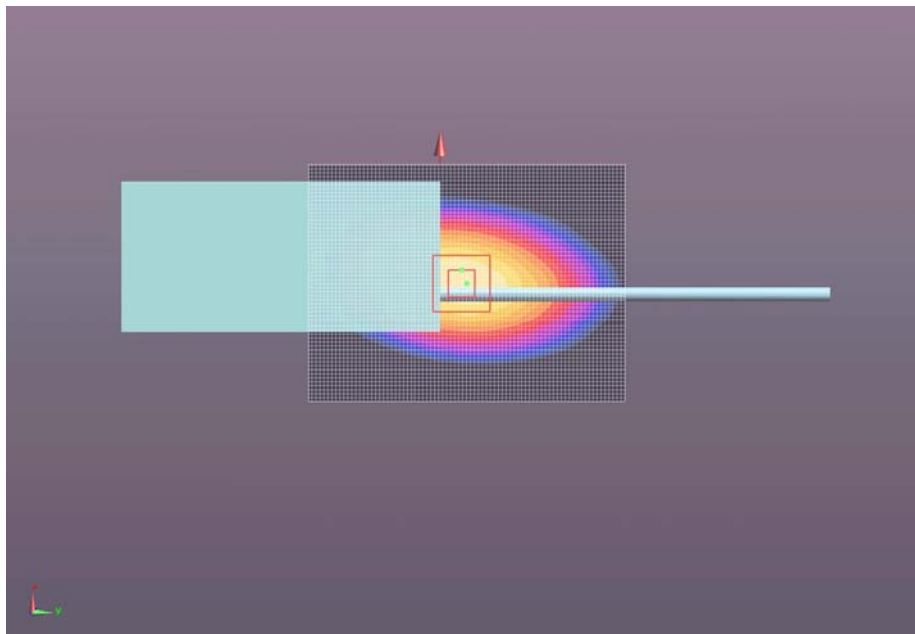

ULTRATECH GROUP OF LABS

3000 Bristol Circle, Oakville, Ontario, Canada L6H 6G4

Tel. #: 905-829-1570, Fax. #: 905-829-8050, Email: vic@ultratech-labs.com, Website: <http://www.ultratech-labs.com>

File #: ICOM-286Q-SAR

February 1, 2012

- All test results contained in this engineering test report are traceable to National Institute of Standards and Technology (NIST)

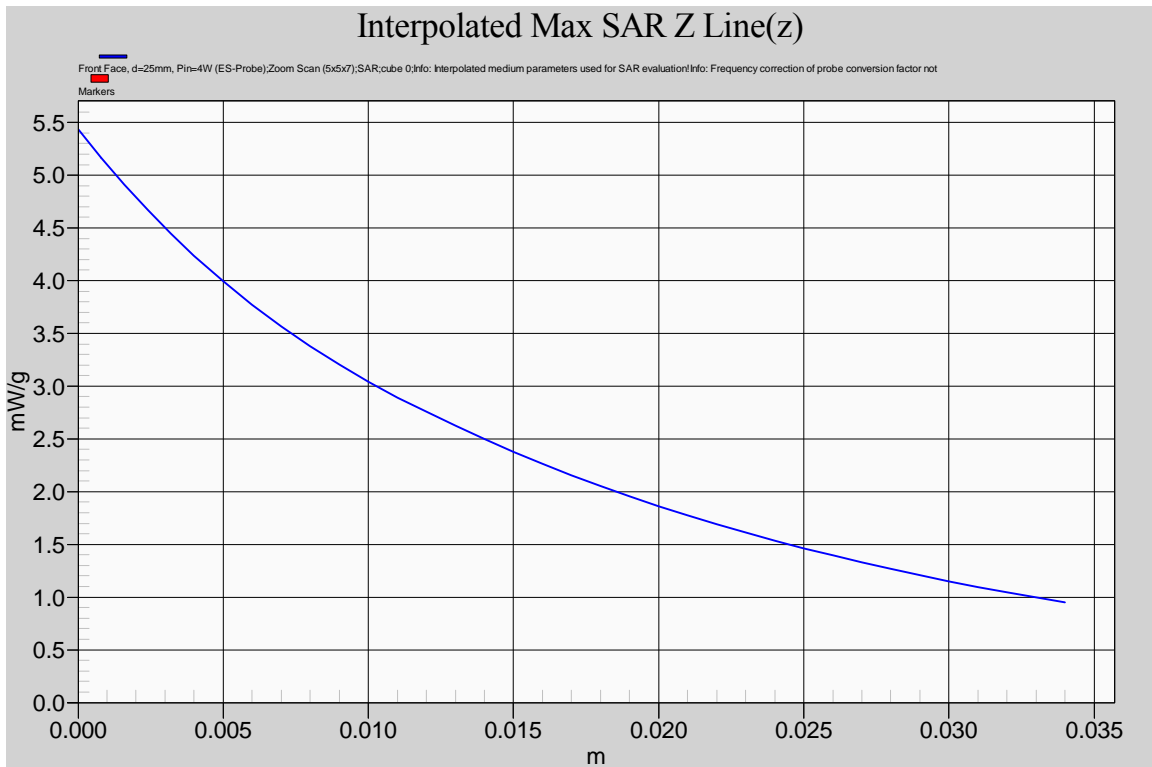

ULTRATECH GROUP OF LABS

3000 Bristol Circle, Oakville, Ontario, Canada L6H 6G4
Tel. #: 905-829-1570, Fax. #: 905-829-8050, Email: vic@ultratech-labs.com, Website: <http://www.ultratech-labs.com>

File #: ICOM-286Q-SAR
February 1, 2012

- All test results contained in this engineering test report are traceable to National Institute of Standards and Technology (NIST)

6.5.2.8. 1/4 helical whip cut antenna (M/N: FA-SC61UC), length=148mm; 440 MHz; #14

Test Laboratory: Ultratech Group of Labs

File Name: [ICOM-286Q_FA-SC61UC=148mm_Head_440MHz\(Mf\).da52](#)**DUT: ICOM UHF Transceiver; Type: IC-F4031S; Serial: 7200001**

Communication System: CW; Frequency: 440 MHz; Duty Cycle: 1:1

Medium parameters used: $f = 440$ MHz; $\sigma = 0.864$ mho/m; $\epsilon_r = 43.567$; $\rho = 1000$ kg/m³

Phantom section: Flat Section

DASY5 Configuration:

- Probe: ES3DV3 - SN3208; ConvF(7.1, 7.1, 7.1); Calibrated: 3/15/2011
- Sensor-Surface: 3.4mm (Mechanical Surface Detection), Sensor-Surface: 4mm (Mechanical Surface Detection)
- Electronics: DAE4 Sn874;
- Phantom: ELI 4.0; Type: QD OVA 001 BB; Serial: 1057
- Measurement SW: DASY52, Version 52.8 (0); SEMCAD X Version 14.6.4 (4989)

Configuration_Head_FA-SC61UC=148mm_MF/Front Face, d=25mm, Pin=4W (ES-Probe)/Area Scan (61x81x1):

Measurement grid: dx=15mm, dy=15mm

Maximum value of SAR (interpolated) = 4.432 mW/g

Configuration_Head_FA-SC61UC=148mm_MF/Front Face, d=25mm, Pin=4W (ES-Probe)/Zoom Scan (5x5x7)**(7x7x7)/Cube 0:** Measurement grid: dx=5mm, dy=5mm, dz=5mm

Reference Value = 72.023 V/m; Power Drift = -0.18 dB

Peak SAR (extrapolated) = 5.2940

SAR(1 g) = 3.84 mW/g; SAR(10 g) = 2.88 mW/g (SAR corrected for target medium)

Maximum value of SAR (measured) = 4.032 mW/g

Configuration_Head_FA-SC61UC=148mm_MF/Front Face, d=25mm, Pin=4W (ES-Probe)/FindMax (11x41x1):

Measurement grid: dx=20mm, dy=20mm

Maximum value of SAR (interpolated) = 4.634 mW/g

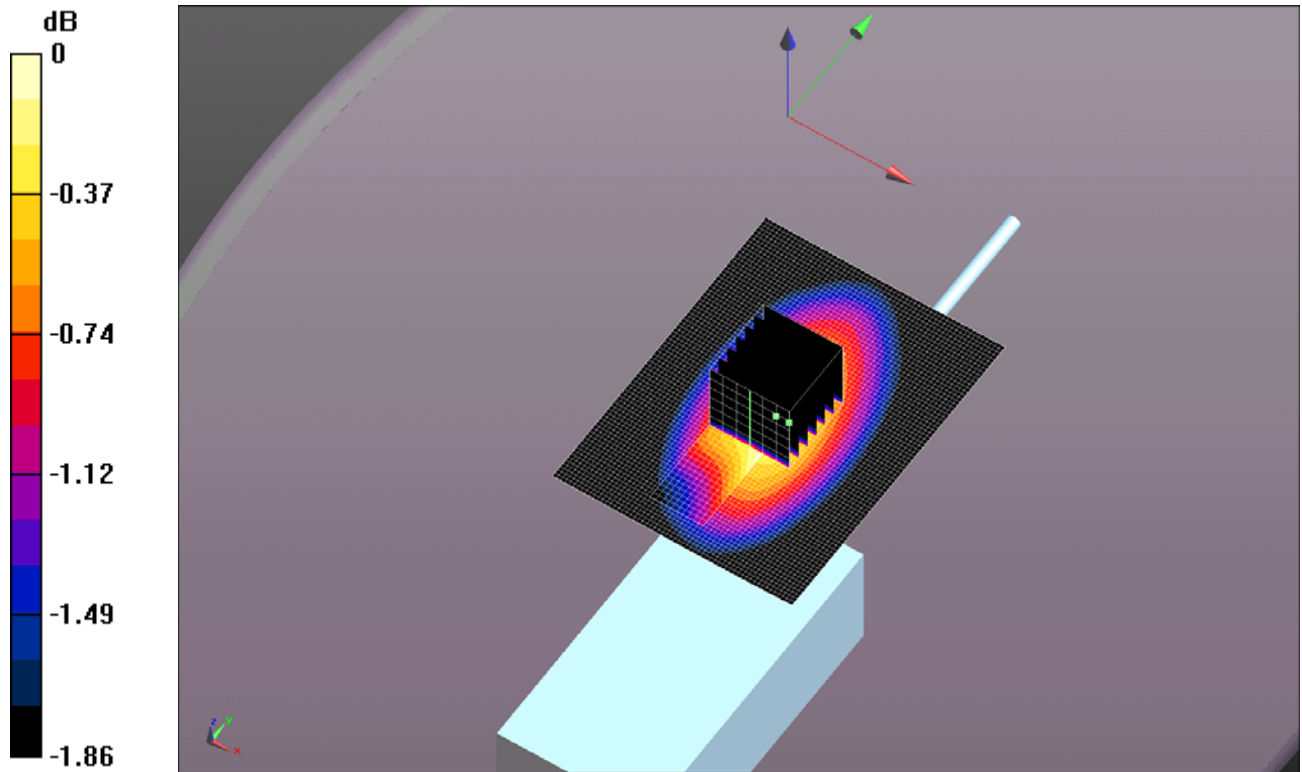

0 dB = 4.630mW/g = 13.31 dB mW/g

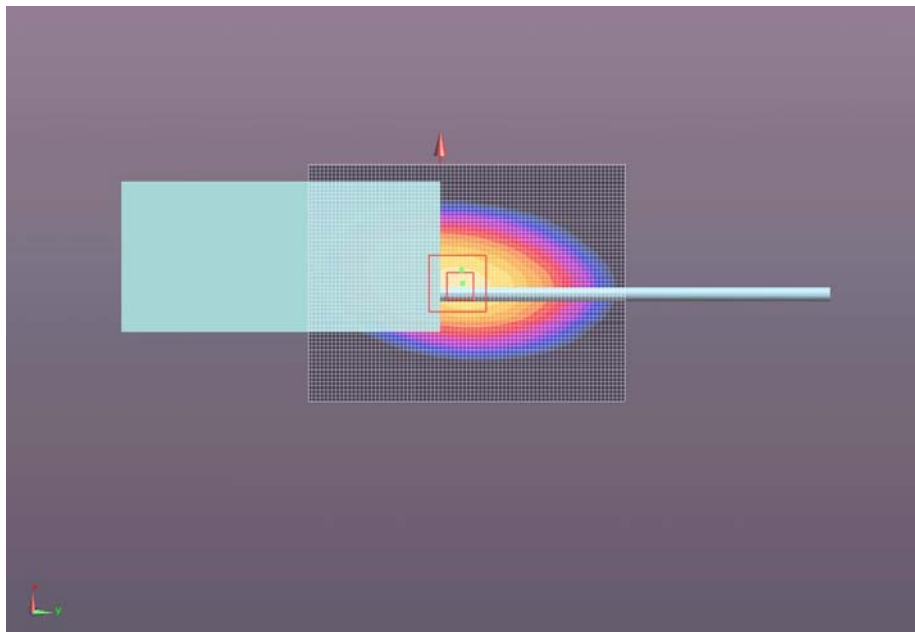

ULTRATECH GROUP OF LABS

3000 Bristol Circle, Oakville, Ontario, Canada L6H 6G4

Tel. #: 905-829-1570, Fax. #: 905-829-8050, Email: vic@ultratech-labs.com, Website: <http://www.ultratech-labs.com>

File #: ICOM-286Q-SAR

February 1, 2012

- All test results contained in this engineering test report are traceable to National Institute of Standards and Technology (NIST)

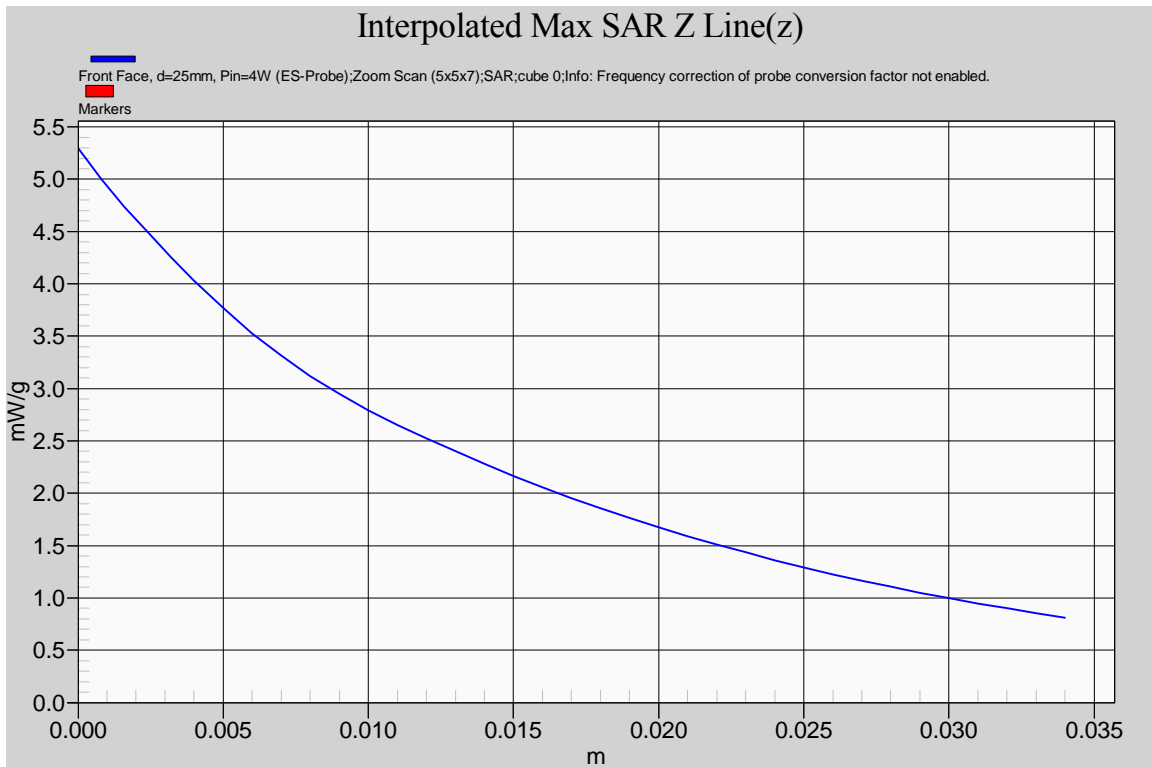

ULTRATECH GROUP OF LABS

3000 Bristol Circle, Oakville, Ontario, Canada L6H 6G4
Tel. #: 905-829-1570, Fax. #: 905-829-8050, Email: vic@ultratech-labs.com, Website: <http://www.ultratech-labs.com>

File #: ICOM-286Q-SAR

February 1, 2012

- All test results contained in this engineering test report are traceable to National Institute of Standards and Technology (NIST)

6.5.2.9. 1/4 helical whip cut antenna (M/N: FA-SC61UC), length=148mm; 469.9 MHz; #15

Test Laboratory: Ultratech Group of Labs

File Name: [ICOM-286Q_FA-SC61UC=148mm_Head_469.9MHz\(Hf\).da52](#)**DUT: ICOM UHF Transceiver; Type: IC-F4031S; Serial: 7200001**

Communication System: CW; Frequency: 469.9 MHz; Duty Cycle: 1:1

Medium parameters used: $f = 470$ MHz; $\sigma = 0.889$ mho/m; $\epsilon_r = 42.931$; $\rho = 1000$ kg/m³

Phantom section: Flat Section

DASY5 Configuration:

- Probe: ES3DV3 - SN3208; ConvF(7.1, 7.1, 7.1); Calibrated: 3/15/2011
- Sensor-Surface: 3.4mm (Mechanical Surface Detection), Sensor-Surface: 4mm (Mechanical Surface Detection)
- Electronics: DAE4 Sn874;
- Phantom: ELI 4.0; Type: QD OVA 001 BB; Serial: 1057
- Measurement SW: DASY52, Version 52.8 (0); SEMCAD X Version 14.6.4 (4989)

Configuration_Head_FA-SC61UC=148mm_HF/Front Face, d=25mm, Pin=4W (ES-Probe)/Area Scan (61x81x1):

Measurement grid: dx=15mm, dy=15mm

Maximum value of SAR (interpolated) = 2.600 mW/g

Configuration_Head_FA-SC61UC=148mm_HF/Front Face, d=25mm, Pin=4W (ES-Probe)/Zoom Scan (5x5x7)**(7x7x7)/Cube 0:** Measurement grid: dx=5mm, dy=5mm, dz=5mm

Reference Value = 54.822 V/m; Power Drift = -0.20 dB

Peak SAR (extrapolated) = 3.0280

SAR(1 g) = 2.17 mW/g; SAR(10 g) = 1.62 mW/g (SAR corrected for target medium)

Maximum value of SAR (measured) = 2.323 mW/g

Configuration_Head_FA-SC61UC=148mm_HF/Front Face, d=25mm, Pin=4W (ES-Probe)/FindMax (11x41x1):

Measurement grid: dx=20mm, dy=20mm

Maximum value of SAR (interpolated) = 2.779 mW/g