

# ENGINEERING TEST REPORT

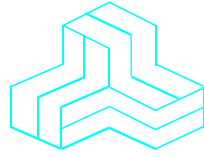

**VHF Air Band Transceiver**  
**Model No.: IC-A24 / IC-A6**  
**FCC ID: AFJ279100**

*Applicant:*

**ICOM Incorporated**  
1-1-32, Kamiminami, Hirano-ku  
Osaka  
Japan, 547-0003

*Tested in Accordance With*

**Federal Communications Commission (FCC)**  
**47 CFR, Parts 2 and 87 (Subpart D) – Aviation Services**

**UltraTech's File No.: ICOM-091F87**

This Test report is Issued under the Authority of  
Tri M. Luu, Professional Engineer,  
Vice President of Engineering  
UltraTech Group of Labs

Date: November 8, 2004



Report Prepared by: Dan Huynh

Tested by: Wayne Wu, EMI/RFI Technician  
Hung Trinh, EMI/RFI Technician

Issued Date: November 8, 2004

Test Dates: October 1-25, 2004

- *The results in this Test Report apply only to the sample(s) tested, and the sample tested is randomly selected.*
- *This report must not be used by the client to claim product endorsement by NVLAP or any agency of the US Government.*

## UltraTech

3000 Bristol Circle, Oakville, Ontario, Canada, L6H 6G4  
Tel.: (905) 829-1570 Fax.: (905) 829-8050

Website: [www.ultratech-labs.com](http://www.ultratech-labs.com), Email: [vic@ultratech-labs.com](mailto:vic@ultratech-labs.com), Email: [tri@ultratech-labs.com](mailto:tri@ultratech-labs.com)



31040/SIT



C-1376



46390-2049



200093-0



SL2-IN-E-1119R



00-034



## TABLE OF CONTENTS

<b>EXHIBIT 1.</b>	<b>SUBMITTAL CHECK LIST .....</b>	<b>1</b>
<b>EXHIBIT 2.</b>	<b>INTRODUCTION.....</b>	<b>2</b>
2.1.	SCOPE .....	2
2.2.	RELATED SUBMITTAL(S)/GRANT(S).....	2
2.3.	NORMATIVE REFERENCES .....	2
<b>EXHIBIT 3.</b>	<b>PERFORMANCE ASSESSMENT .....</b>	<b>3</b>
3.1.	CLIENT INFORMATION.....	3
3.2.	EQUIPMENT UNDER TEST (EUT) INFORMATION.....	3
3.3.	EUT'S TECHNICAL SPECIFICATIONS.....	4
3.4.	LIST OF EUT'S PORTS.....	4
<b>EXHIBIT 4.</b>	<b>EUT OPERATING CONDITION AND CONFIGURATIONS DURING TESTS.....</b>	<b>5</b>
4.1.	CLIMATE TEST CONDITIONS .....	5
4.2.	OPERATIONAL TEST CONDITIONS & ARRANGEMENT FOR TEST SIGNALS .....	5
<b>EXHIBIT 5.</b>	<b>SUMMARY OF TEST RESULTS.....</b>	<b>6</b>
5.1.	LOCATION OF TESTS.....	6
5.2.	APPLICABILITY & SUMMARY OF EMISSION TEST RESULTS.....	6
5.3.	MODIFICATIONS INCORPORATED IN THE EUT FOR COMPLIANCE PURPOSES.....	6
5.4.	DEVIATION OF STANDARD TEST PROCEDURES .....	6
<b>EXHIBIT 6.</b>	<b>MEASUREMENTS, EXAMINATIONS &amp; TEST DATA FOR EMC EMISSIONS .....</b>	<b>7</b>
6.1.	TEST PROCEDURES .....	7
6.2.	MEASUREMENT UNCERTAINTIES .....	7
6.3.	MEASUREMENT EQUIPMENT USED .....	7
6.4.	ESSENTIAL/PRIMARY FUNCTIONS AS DECLARED BY THE MANUFACTURER .....	7
6.5.	RF POWER OUTPUT [§§ 2.1046 & 87.131].....	8
6.6.	MODULATION CHARACTERISTICS - AUDIO FREQUENCY RESPONSE [§§ 2.1047(a) & 87.141(f)].....	10
6.7.	MODULATION CHARACTERISTICS – MODULATION LIMITING [§§ 2.1047(b) & 87.141] .....	13
6.8.	OCCUPIED BANDWIDTH AND EMISSION LIMITATIONS [§§ 2.1049, 87.135 & 87.139].....	17
6.9.	SPURIOUS EMISSIONS AT ANTENNA TERMINAL [§§ 2.1051, 87.139].....	24
6.10.	FIELD STRENGTH OF SPURIOUS EMISSIONS [§§ 2.1053, 87.139] .....	31
6.11.	FREQUENCY STABILITY [§§ 2.1055 & 87.133].....	33
<b>EXHIBIT 7.</b>	<b>MEASUREMENT UNCERTAINTY.....</b>	<b>36</b>
7.1.	RADIATED EMISSION MEASUREMENT UNCERTAINTY .....	36
<b>EXHIBIT 8.</b>	<b>MEASUREMENT METHODS.....</b>	<b>37</b>
8.1.	CONDUCTED POWER MEASUREMENTS .....	37
8.2.	RADIATED POWER MEASUREMENTS (ERP & EIRP) USING SUBSTITUTION METHOD.....	38
8.3.	FREQUENCY STABILITY .....	41
8.4.	EMISSION LIMITATIONS.....	42
8.5.	SPURIOUS EMISSIONS (CONDUCTED).....	42

---

**ULTRATECH GROUP OF LABS**

3000 Bristol Circle, Oakville, Ontario, Canada L6H 6G4  
Tel. #: 905-829-1570, Fax. #: 905-829-8050, Email: [vic@ultratech-labs.com](mailto:vic@ultratech-labs.com), Website: <http://www.ultratech-labs.com>

File #: ICOM-091F87

November 8, 2004

All test results contained in this engineering test report are traceable to National Institute of Standards and Technology (NIST)

## EXHIBIT 1. SUBMITTAL CHECK LIST

Annex No.	Exhibit Type	Description of Contents	Quality Check (OK)
--	Test Report	Test Report	OK
1	Test Setup Photos	Radiated Emissions Setup Photos	OK
2	External Photos of EUT	External Photos	OK
3	Internal Photos of EUT	Internal Photos	OK
4	Cover Letters	<ul style="list-style-type: none"> <li>▪ Letter from Ultratech for Certification Request</li> <li>▪ Letter from the Applicant to appoint Ultratech to act as an agent</li> <li>▪ Letter from the Applicant to request for Confidentiality Filing</li> <li>▪ FAA Notification Letter</li> </ul>	OK
5	Attestation Statements	--	--
6	ID Label/Location Info	<ul style="list-style-type: none"> <li>▪ ID Label</li> <li>▪ Location of ID Label</li> </ul>	OK
7	Block Diagrams	Block diagram	OK
8	Schematic Diagrams	Schematics	OK
9	Parts List/Tune Up Info	<ul style="list-style-type: none"> <li>▪ Parts List</li> <li>▪ Tune Up/Adjustment Procedures</li> </ul>	OK
10	Operational Description	Circuit Description	OK
11	RF Exposure Info	Routine SAR evaluation is not required, the device is below the low power threshold and all requirements are satisfied by the device/antenna operating configurations and exposure conditions.	OK
12	Users Manual	Instruction Manual	OK

### ULTRATECH GROUP OF LABS

3000 Bristol Circle, Oakville, Ontario, Canada L6H 6G4  
Tel. #: 905-829-1570, Fax. #: 905-829-8050, Email: [vic@ultratech-labs.com](mailto:vic@ultratech-labs.com), Website: <http://www.ultratech-labs.com>

File #: ICOM-091F87  
November 8, 2004

*All test results contained in this engineering test report are traceable to National Institute of Standards and Technology (NIST)*

## EXHIBIT 2. INTRODUCTION

### 2.1. SCOPE

<b>Reference:</b>	FCC Parts 2 and 87
<b>Title:</b>	Code of Federal Regulations (CFR), Title 47 Telecommunication – Parts 2 & 87
<b>Purpose of Test:</b>	To obtain FCC Certification Authorization for Radio operating in the frequency band 118-137 MHz.
<b>Test Procedures:</b>	Both conducted and radiated emissions measurements were conducted in accordance with American National Standards Institute ANSI C63.4 - American National Standard for Methods of Measurement of Radio-Noise Emissions from Low-Voltage Electrical and Electronic Equipment in the Range of 9 kHz to 40 GHz.

### 2.2. RELATED SUBMITTAL(S)/GRANT(S)

None.

### 2.3. NORMATIVE REFERENCES

Publication	Year	Title
FCC CFR Parts 0-19, 80-End	2003	Code of Federal Regulations – Telecommunication
ANSI C63.4	2003	American National Standard for Methods of Measurement of Radio-Noise Emissions from Low-Voltage Electrical and Electronic Equipment in the Range of 9 kHz to 40 GHz
CISPR 16-1	2003	Specification for Radio Disturbance and Immunity measuring apparatus and methods
TIA/EIA 603, Edition B	2002	Land Mobile FM or PM Communications Equipment Measurement and Performance Standards

### EXHIBIT 3. PERFORMANCE ASSESSMENT

#### 3.1. CLIENT INFORMATION

APPLICANT	
<b>Name:</b>	Icom Incorporated
<b>Address:</b>	1-1-32 kamiminami Hirano-ku Osaka 547-0003 Japan
<b>Contact Person:</b>	Mr. Takashi Aoki Phone #: +81-66-793-5302 Fax #: +81-66-793-0013 Email Address: <a href="mailto:export@icom.co.jp">export@icom.co.jp</a>

MANUFACTURER	
<b>Name:</b>	Icom Incorporated
<b>Address:</b>	1-1-32 kamiminami Hirano-ku Osaka 547-0003 Japan
<b>Contact Person:</b>	Mr. Takashi Aoki Phone #: +81-66-793-5302 Fax #: +81-66-793-0013 Email Address: <a href="mailto:export@icom.co.jp">export@icom.co.jp</a>

#### 3.2. EQUIPMENT UNDER TEST (EUT) INFORMATION

The following information (with the exception of the Date of Receipt) has been supplied by the applicant.

<b>Brand Name:</b>	ICOM Incorporated
<b>Product Name:</b>	VHF Air Band Transceiver
<b>Model Name or Number:</b>	IC-A24 / IC-A6
<b>Serial Number:</b>	Test Sample
<b>External Power Supply:</b>	N/A
<b>Transmitting/Receiving Antenna Type:</b>	Non-integral
<b>Type of Equipment:</b>	Non-broadcast Radio Communication Equipment
<b>Primary User Functions of EUT:</b>	VHF air band transceiver for voice communication in occupational environment.

### 3.3. EUT'S TECHNICAL SPECIFICATIONS

<b>TRANSMITTER</b>	
<b>Equipment Type:</b>	Portable
<b>Intended Operating Environment:</b>	Aviation Services
<b>Power Supply Requirement:</b>	Specified battery packs/case or 11.0 VDC at external DC jack
<b>RF Output Power Rating:</b>	1.5W (CW) Conducted
<b>Operating Frequency Range:</b>	118.000-136.975 MHz
<b>RF Output Impedance:</b>	50 Ohms
<b>Channel Spacing:</b>	25.0 KHz
<b>Emission Designation*:</b>	6K00A3E
<b>Antenna Connector Type:</b>	BNC
<b>Antenna Description:</b>	Manufacturer: ICOM Inc. Type: Quarter wave whip antenna Model: FA-B02AR Frequency Range: VHF Gain (dBi): -1.5dBi

\* For an average case of commercial telephony, the Necessary Bandwidth is calculated as follows:

#### Calculation of Necessary Bandwidth for Telephony (Commercial Quality)

Telephony, double-sideband (single channel):

$$B_n = 2M$$

Where:  $B_n$  = necessary bandwidth in hertz  
 $M$  = maximum modulation frequency in hertz

$$M = 3000\text{Hz}$$

$$B_n = 2(3000) = 6000 \text{ Hz} = 6.00 \text{ KHz}$$

### 3.4. LIST OF EUT'S PORTS

Port Number	EUT's Port Description	Number of Identical Ports	Connector Type	Cable Type (Shielded/Non-shielded)
1	Antenna	1	BNC	N/A
2	Speaker-Microphone Connector	1	SP MIC Jack	Shielded
3	External DC Jack	1	DC Jack	Non-shielded

#### **ULTRATECH GROUP OF LABS**

3000 Bristol Circle, Oakville, Ontario, Canada L6H 6G4  
Tel. #: 905-829-1570, Fax. #: 905-829-8050, Email: [vic@ultratech-labs.com](mailto:vic@ultratech-labs.com), Website: <http://www.ultratech-labs.com>

File #: ICOM-091F87  
November 8, 2004

All test results contained in this engineering test report are traceable to National Institute of Standards and Technology (NIST)

## EXHIBIT 4. EUT OPERATING CONDITION AND CONFIGURATIONS DURING TESTS

### 4.1. CLIMATE TEST CONDITIONS

The climate conditions of the test environment are as follows:

Temperature:	21°C
Humidity:	51%
Pressure:	102 kPa
Power input source:	7.2 V/1650 mAh Ni-MH battery pack

### 4.2. OPERATIONAL TEST CONDITIONS & ARRANGEMENT FOR TEST SIGNALS

<b>Operating Modes:</b>	The transmitter was operated in a continuous transmission mode with the carrier modulated as specified in the Test Data.
<b>Special Test Software:</b>	N/A
<b>Special Hardware Used:</b>	None
<b>Transmitter Test Antenna:</b>	The EUT is tested with the transmitter antenna port terminated to a 50 Ohms RF Load.

<b>Transmitter Test Signals</b>	
<b>Frequency Band(s):</b>	118.000-136.975 MHz
<b>Test Frequency(ies):</b> (Near lowest, near middle & near highest frequencies in the frequency range of operation.)	118.000, 127.050 and 136.975 MHz
<b>Transmitter Wanted Output Test Signals:</b>	
<ul style="list-style-type: none"> <li>▪ RF Power Output (measured maximum output power):</li> <li>▪ Normal Test Modulation:</li> <li>▪ Modulating signal source:</li> </ul>	<p>1.5 W</p> <p>AM or 2500 Hz tone at an input level 16 dB greater than that necessary to produce 50 percent modulation.</p> <p>External</p>

## EXHIBIT 5. SUMMARY OF TEST RESULTS

### 5.1. LOCATION OF TESTS

All of the measurements described in this report were performed at Ultratech Group of Labs located in the city of Oakville, Province of Ontario, Canada.

Radiated Emissions were performed at the Ultratech's 3 Meter Open Field Test Site (OFTS) situated in the Town of Oakville, province of Ontario.

The above site have been calibrated in accordance with ANSI C63.4, and found to be in compliance with the requirements of Sec. 2.948 of the FCC Rules. The descriptions and site measurement data of the Oakville Open Field Test Site has been filed with FCC office (FCC File No.: 31040/SIT 1300B3) and Industry Canada office (Industry Canada File No.: IC 2049). Last Date of Site Calibration: February 17, 2004.

### 5.2. APPLICABILITY & SUMMARY OF EMISSION TEST RESULTS

FCC Section(s)	Test Requirements	Applicability (Yes/No)
2.1046 & 87.131	RF Power Output	Yes
1.1307, 1.1310, 2.1091 & 2.1093	RF Exposure Limit	Yes
2.1047(a) & 87.141(f)	Modulation Characteristics - Audio Frequency Response of Lowpass Filter	Yes
2.1047(b) & 87.141	Modulation Characteristics - Modulation Limiting	Yes
2.1049, 87.135 & 87.139	Occupied Bandwidth and Emission Limitations	Yes
2.1051, 2.1057 & 87.139,	Spurious Emissions at Antenna Terminal	Yes
2.1053, 2.1057 & 87.139	Field Strength of Spurious Emissions	Yes
2.1055 & 87.133	Frequency Stability	Yes
<b>VHF Air Band Transceiver, Model No.: IC-A24 / IC-A6, by ICOM Incorporated, has also been tested and found to comply with FCC Part 15, Subpart B - Radio Receivers and Class B Digital Devices. The engineering test report has been documented and it is available upon request.</b>		

### 5.3. MODIFICATIONS INCORPORATED IN THE EUT FOR COMPLIANCE PURPOSES

None.

### 5.4. DEVIATION OF STANDARD TEST PROCEDURES

None.

---

#### ULTRATECH GROUP OF LABS

3000 Bristol Circle, Oakville, Ontario, Canada L6H 6G4  
Tel. #: 905-829-1570, Fax. #: 905-829-8050, Email: [vic@ultratech-labs.com](mailto:vic@ultratech-labs.com), Website: <http://www.ultratech-labs.com>

File #: ICOM-091F87  
November 8, 2004

All test results contained in this engineering test report are traceable to National Institute of Standards and Technology (NIST)



---

---

## **EXHIBIT 6. MEASUREMENTS, EXAMINATIONS & TEST DATA FOR EMC EMISSIONS**

### **6.1. TEST PROCEDURES**

This section contains test results only. Details of test methods and procedures can be found in Exhibit 8 of this report.

### **6.2. MEASUREMENT UNCERTAINTIES**

The measurement uncertainties stated were calculated in accordance with requirements of UKAS Document NIS 81 with a confidence level of 95%. Please refer to Exhibit 7 for Measurement Uncertainties.

### **6.3. MEASUREMENT EQUIPMENT USED**

The measurement equipment used complied with the requirements of the Standards referenced in the Methods & Procedures ANSI C63.4 and CISPR 16-1.

### **6.4. ESSENTIAL/PRIMARY FUNCTIONS AS DECLARED BY THE MANUFACTURER**

The essential function of the EUT is to correctly communicate data to and from radios over RF link.

## 6.5. RF POWER OUTPUT [§§ 2.1046 & 87.131]

### 6.5.1. Limits

The following table lists authorized emissions and maximum power. Power must be determined by direct measurement.

Class of station	Frequency band/ frequency	Authorized emission(s) <sup>2</sup>	Maximum power <sup>1</sup>
Aeronautical advisory	VHF	A3E	10 watts <sup>3</sup>
Aeronautical multicom	VHF	A3E	10 watts
Aeronautical search and rescue	VHF	A3E	10 watts
Aeronautical utility mobile	VHF	A3E	10 watts

#### Notes:

- (1) The power is measured at the transmitter output terminals and the type of power is determined according to the emission designator as follows:
  - (i) Mean power (pY) for amplitude modulated emissions and transmitting both sidebands using unmodulated full carrier.
  - (ii) Peak envelope power (pX) for all emission designators other than those referred to in paragraph (i) of this note.
- (2) Excludes automatic link establishment.
- (3) Power is limited to 0.5 watt, but may not exceed 2 watts when station is used in an automatic unattended mode.

### 6.5.2. Method of Measurements

Refer to Exhibit 8, Section 8.1 of this report for measurement details.

### 6.5.3. Test Equipment List

Test Instruments	Manufacturer	Model No.	Serial No.	Frequency Range
Power Meter	Hewlett Packard	436A	1725A02249	10 kHz – 50 GHz, sensor dependent
Power Sensor	Hewlett-Packard	8481A	1550A07043	10M-18G Hz
Attenuator	Weinschel	23-20-34	BH7876	20dB DC-18G Hz 10W

---

#### ULTRATECH GROUP OF LABS

3000 Bristol Circle, Oakville, Ontario, Canada L6H 6G4  
Tel. #: 905-829-1570, Fax. #: 905-829-8050, Email: [vic@ultratech-labs.com](mailto:vic@ultratech-labs.com), Website: <http://www.ultratech-labs.com>

File #: ICOM-091F87  
November 8, 2004

All test results contained in this engineering test report are traceable to National Institute of Standards and Technology (NIST)

#### 6.5.4. Test Arrangement

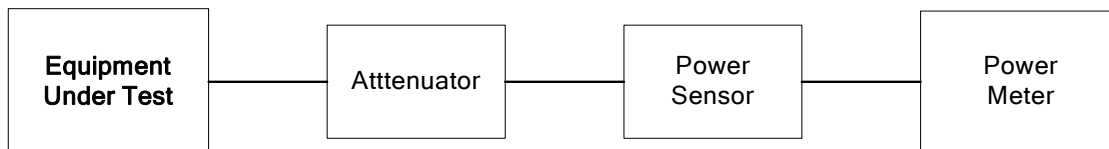

#### 6.5.5. Test Data

Transmitter Channel Output	Fundamental Frequency (MHz)	Measured (Average) Power @ Antenna Port (watts)	Maximum Power Limit (watts)
Lowest	118.000	1.486	10
Middle	127.050	1.442	10
Highest	136.975	1.486	10

**6.6. MODULATION CHARACTERISTICS - AUDIO FREQUENCY RESPONSE [§§ 2.1047(a) & 87.141(f)]**

**6.6.1. Limits**

**87.141(f)** Each frequency modulated transmitter equipped with a modulation limiter must have a low pass filter between the modulation limiter and the modulated stage. At audio frequencies between 3 kHz and 15 kHz, the filter must have an attenuation greater than the attenuation at 1 kHz by at least  $40 \log_{10}(f/3)$  db where “f” is the frequency in kilohertz. Above 15 kHz, the attenuation must be at least 28 db greater than the attenuation at 1 kHz.

**6.6.2. Method of Measurements**

The rated audio input signal was applied to the input of the audio lowpass filter (or of all modulation stages) using an audio oscillator, this input signal level and its corresponding output signal were then measured and recorded using the FFT (Audio) spectrum analyzer. Tests were repeated at different audio signal frequencies from 0 to 50 kHz.

**6.6.3. Test Equipment List**

Test Instruments	Manufacturer	Model No.	Serial No.	Frequency Range
FFT (audio) Spectrum Analyzer	Advantest	R9211E	...	10 mHz-100 kHz, 1 MHz Input Impedance
Radio Communication Test Set	Marconi Instruments	2955	132037/226	AF SG 20Hz-20KHz
Attenuator	Weinschel	23-20-34	BH7876	20dB DC-18G Hz 10W
Modulation Analyzer	Hewlett-Packard	8901B	3226A04606	150K-1300M Hz

**6.6.4. Test Arrangement**

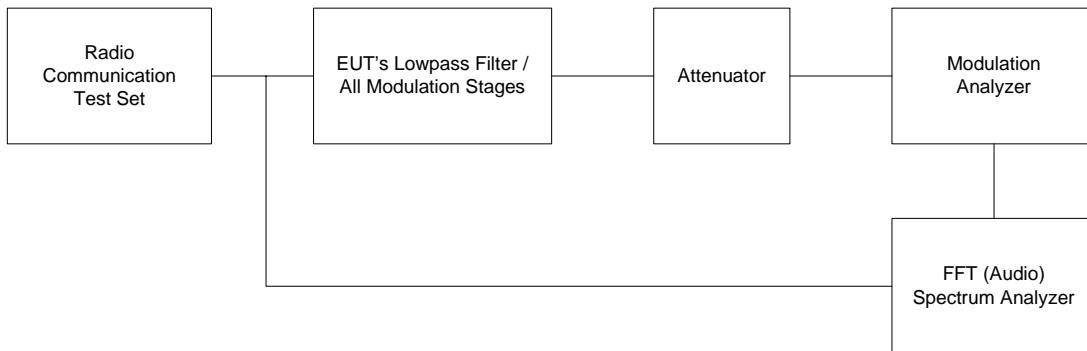

**6.6.5. Test Data**

**Note:** Due to the difficulty of measuring the Frequency Response of the internal lowpass filter, the Frequency Response of All Modulation States was performed to show the roll-off at 3 kHz in comparison with FCC Limit for audio lowpass filter.

**25 kHz Channel Spacing, Frequency of All Modulation States\***

Frequency (kHz)	Audio IN (dBV)	Audio OUT (dBV)	Attenuation (OUT - IN) (dB)	Attenuation wrt. 1 kHz (dB)	Recommended Attenuation (dB)
0.1	-30.31	-18.51	11.8	-6.2	--
0.2	-30.31	-14.23	16.1	-2.0	--
0.4	-30.31	-11.48	18.8	0.8	--
0.6	-30.31	-11.37	18.9	0.9	--
0.8	-30.31	-11.77	18.5	0.5	--
1.0	-30.31	-12.27	18.0	0.0	--
1.5	-30.31	-12.79	17.5	-0.5	--
2.0	-30.31	-13.34	17.0	-1.1	--
2.5	-30.31	-13.82	16.5	-1.6	--
3.0	-30.31	-14.17	16.1	-1.9	0
3.5	-30.31	-19.96	10.4	-7.7	-3
4.0	-30.31	-28.32	2.0	-16.1	-5
4.5	-30.31	-35.56	-5.3	-23.3	-7
5.0	-30.31	-41.66	-11.4	-29.4	-9
6.0	-30.31	-51.01	-20.7	-38.7	-12
7.0	-30.31	-58.90	-28.6	-46.6	-15
8.0	-30.31	-65.60	-35.3	-53.3	-17
9.0	-30.31	-71.34	-41.0	-59.1	-19
10.0	-30.31	-76.90	-46.6	-64.6	-21
12.0	-30.31	-85.01	-54.7	-72.7	-24
14.0	-30.31	<-90.00	<-59.7	<-77.7	-27
16.0	-30.31	<-90.00	<-59.7	<-77.7	-28
18.0	-30.31	<-90.00	<-59.7	<-77.7	-28
20.0	-30.31	<-90.00	<-59.7	<-77.7	-28
25.0	-30.31	<-90.00	<-59.7	<-77.7	-28
30.0	-30.31	<-90.00	<-59.7	<-77.7	-28
35.0	-30.31	<-90.00	<-59.7	<-77.7	-28
40.0	-30.31	<-90.00	<-59.7	<-77.7	-28
45.0	-30.31	<-90.00	<-59.7	<-77.7	-28
50.0	-30.31	<-90.00	<-59.7	<-77.7	-28

**ULTRATECH GROUP OF LABS**

3000 Bristol Circle, Oakville, Ontario, Canada L6H 6G4  
Tel. #: 905-829-1570, Fax. #: 905-829-8050, Email: [vic@ultratech-labs.com](mailto:vic@ultratech-labs.com), Website: <http://www.ultratech-labs.com>

File #: ICOM-091F87

November 8, 2004

All test results contained in this engineering test report are traceable to National Institute of Standards and Technology (NIST)

Audio Frequency Response  
25 kHz Channel Spacing

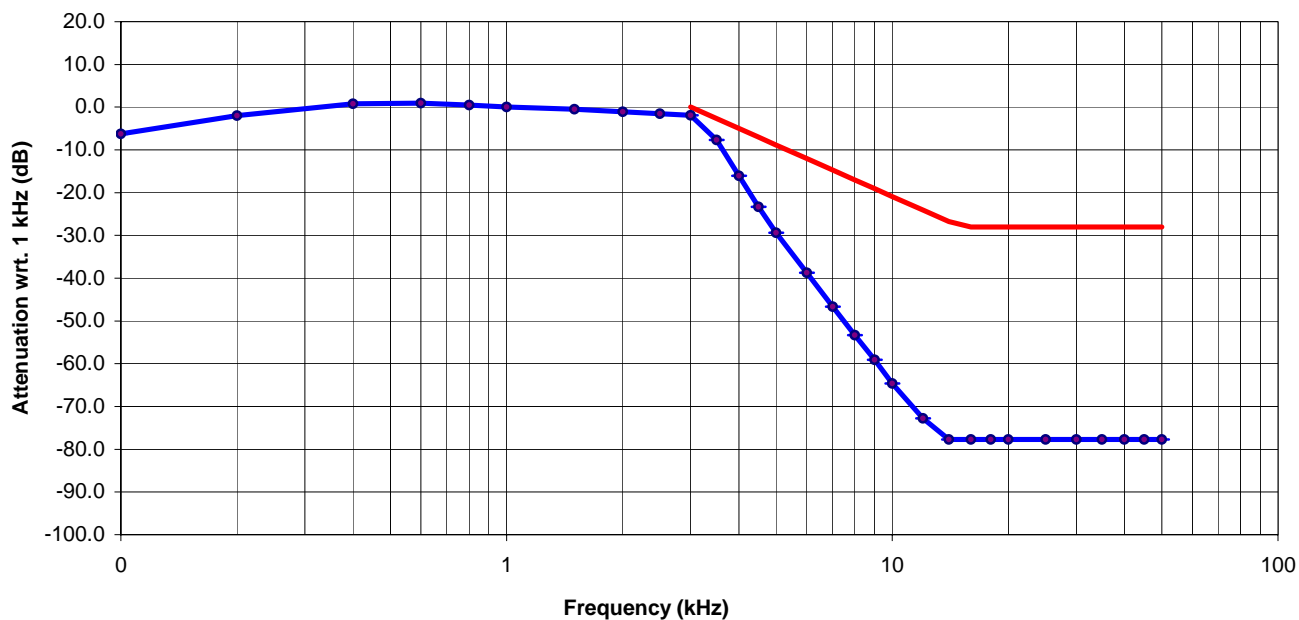

**ULTRATECH GROUP OF LABS**

3000 Bristol Circle, Oakville, Ontario, Canada L6H 6G4  
Tel. #: 905-829-1570, Fax. #: 905-829-8050, Email: [vic@ultratech-labs.com](mailto:vic@ultratech-labs.com), Website: <http://www.ultratech-labs.com>

File #: ICOM-091F87  
November 8, 2004

All test results contained in this engineering test report are traceable to National Institute of Standards and Technology (NIST)

## 6.7. MODULATION CHARACTERISTICS – MODULATION LIMITING [§§ 2.1047(b) & 87.141]

### 6.7.1. Limits

- (a) When A3E emission is used, the modulation percentage must not exceed 100 percent. This requirement does not apply to emergency locator transmitters or survival craft transmitters.
- (b) A double sideband full carrier amplitude modulated radiotelephone transmitter with rated carrier power output exceeding 10 watts must be capable of automatically preventing modulation in excess of 100 percent.
- (c) If any licensed radiotelephone transmitter causes harmful interference to any authorized radio service because of excessive modulation, the Commission will require the use of the transmitter to be discontinued until it is rendered capable of automatically preventing modulation in excess of 100 percent.

### 6.7.2. Method of Measurements

**For Audio Transmitter:-** The carrier frequency deviation was measured with the tone input signal level varied from 0 Vp to audio input rating level plus 16 dB at frequencies 0.1, 0.5, 1.0, 3.0 and 5.0 kHz. The maximum deviation was recorded at each test condition.

**For Data Transmitter with Maximum Frequency Deviation set by Factory:-** The EUT was set at maximum frequency deviation, and its peak frequency deviation was then measured using EUT’s internal random data source.

### 6.7.3. Test Equipment List

Test Instruments	Manufacturer	Model No.	Serial No.	Frequency Range
Radio Communication Test Set	Marconi Instruments	2955	132037/226	AF SG 20Hz-20KHz
Attenuator	Weinschel	23-20-34	BH7876	20dB DC-18G Hz 10W
Modulation Analyzer	Hewlett-Packard	8901B	3226A04606	150K--1300M Hz

### 6.7.4. Test Arrangement



**6.7.5. Test Data**

MODULATING SIGNAL LEVEL (mVrms)	Modulation (%) at the following modulating frequency:					MODULATION LIMIT (%) (%)
	0.1 kHz	0.5 kHz	1.0 kHz	3.0 kHz	5.0 kHz	
2	2.38	3.90	4.64	2.89	0.05	100
4	4.39	7.48	7.28	5.55	0.58	100
6	6.44	10.93	10.66	8.07	0.71	100
8	8.43	14.63	13.84	10.72	0.86	100
10	10.38	18.10	17.10	13.30	0.91	100
15	14.63	26.95	25.28	19.67	1.18	100
20	18.29	35.69	33.56	26.18	1.50	100
25	21.50	44.20	41.40	32.59	1.72	100
30	24.36	52.70	49.30	38.90	2.03	100
35	27.03	61.40	57.20	45.20	2.34	100
40	29.47	70.30	65.40	51.50	2.61	100
45	31.48	78.70	73.50	57.90	2.81	100
50	33.50	86.50	81.90	64.50	3.10	100
60	35.26	95.40	93.30	77.30	3.63	100
70	41.30	95.50	95.00	88.40	4.15	100
80	47.10	95.50	94.90	93.50	4.67	100
90	51.80	95.50	94.80	93.30	4.57	100
100	55.60	95.60	94.70	93.20	4.53	100
150	72.90	95.60	94.70	93.00	4.40	100
200	76.40	95.60	94.80	93.00	4.36	100
250	77.10	95.60	94.70	93.00	4.37	100
300	77.50	95.60	94.70	93.00	4.35	100



$$\begin{aligned}
 \text{Voice Signal Input Level} &= \text{STD MOD Level} + 16 \text{ dB} \\
 &= 29.69 \text{ dB(mVrms)} + 16 \text{ dB} \\
 &= 45.69 \text{ dB(mVrms)} \\
 &= 192.53 \text{ mVrms}
 \end{aligned}$$

Standard Modulation Level measured at 50 % Modulation @ 1.0 kHz.

MODULATING FREQUENCY (KHz)	MODULATION (%)	MODULATION LIMIT (%)
0.1	76.4	100
0.2	95.7	100
0.4	95.8	100
0.6	95.5	100
0.8	95.0	100
1.0	94.7	100
1.2	93.9	100
1.4	93.6	100
1.6	93.8	100
1.8	94.2	100
2.0	94.2	100
2.5	93.6	100
3.0	93.0	100
3.5	45.9	100
4.0	17.6	100
4.5	8.0	100
5.0	4.4	100
6.0	1.5	100
7.0	0.8	100
8.0	0.5	100
9.0	0.3	100
10.0	0.3	100

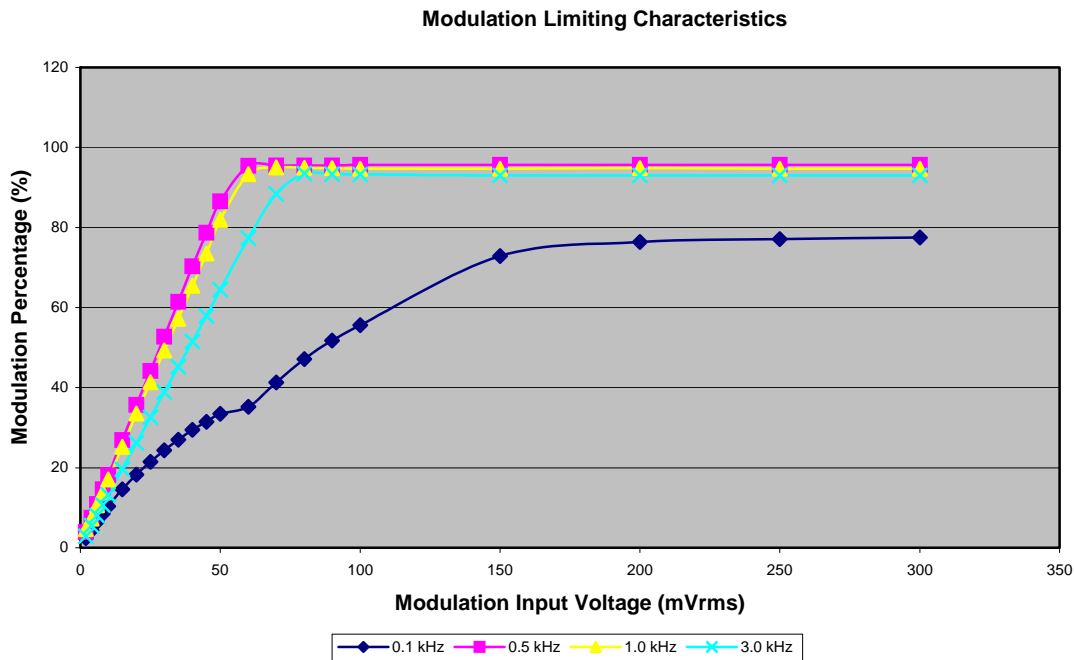

## 6.8. OCCUPIED BANDWIDTH AND EMISSION LIMITATIONS [§§ 2.1049, 87.135 & 87.139]

### 6.8.1. Limits

§ 87.139(a) - Except for ELTs and when using single sideband (R3E, H3E, J3E), or frequency modulation (F9) or digital modulation (F9Y) for telemetry or telecommand in the frequency bands 1435–1535 MHz and 2310–2390 MHz or digital modulation (G7D) for differential GPS, the mean power of any emission must be attenuated below the mean power of the transmitter (pY) as follows:

- (1) When the frequency is removed from the assigned frequency by more than 50 percent up to and including 100 percent of the authorized bandwidth the attenuation must be at least 25 dB;
- (2) When the frequency is removed from the assigned frequency by more than 100 percent up to and including 250 percent of the authorized bandwidth the attenuation must be at least 35 dB.
- (3) When the frequency is removed from the assigned frequency by more than 250 percent of the authorized bandwidth the attenuation for aircraft station transmitters must be at least 40 dB; and the attenuation for aeronautical station transmitters must be at least  $43 + 10 \log_{10} pY$  dB.

### 6.8.2. Method of Measurements

Refer to Exhibit 8, Section 8.4 of this report for measurement details.

### 6.8.3. Test Equipment List

Test Instruments	Manufacturer	Model No.	Serial No.	Frequency Range
Spectrum Analyzer	Advantest	R3271	15050203	100Hz-26.5GHz
Radio Communication Test Set	Marconi Instruments	2955	132037/226	20Hz-20KHz
Attenuator	Weinschel	23-20-34	BH7876	20dB DC-18GHz

### 6.8.4. Test Arrangement



**6.8.5. Test Data**

**6.8.5.1. 99% Occupied Bandwidth**

Frequency (MHz)	*Measured 99% OBW (kHz)	Authorized Bandwidth (kHz)
118.000	9.89	25.0
127.050	10.20	25.0
136.975	9.69	25.0

\* See the following plots (1 – 3) for details of measurements

Plot 1:  
 Occupied Bandwidth  
 Carrier Frequency: 160.050 MHz  
 Power: 1.5 W

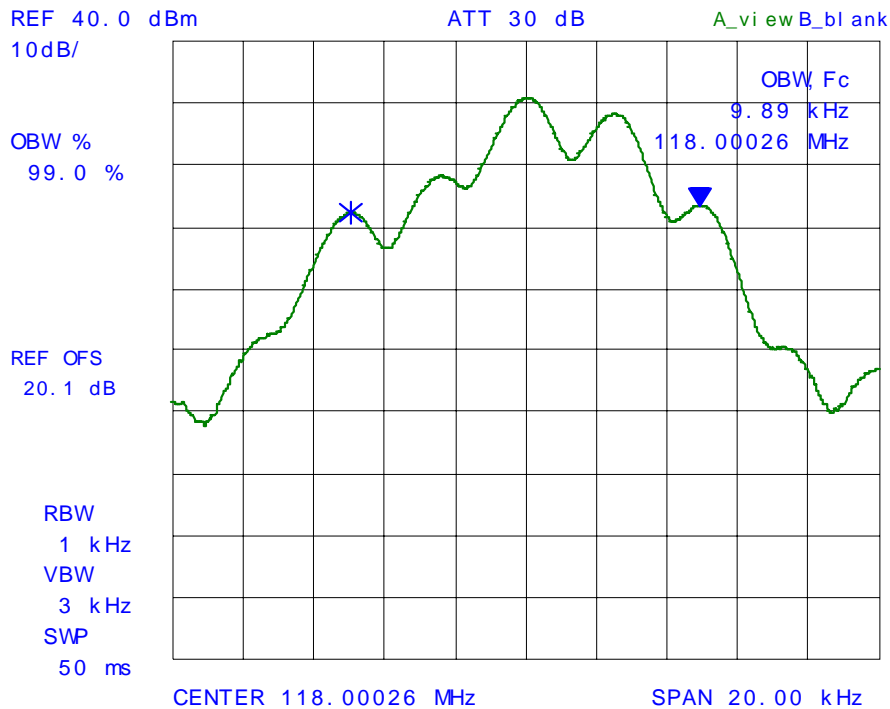

**ULTRATECH GROUP OF LABS**

3000 Bristol Circle, Oakville, Ontario, Canada L6H 6G4  
 Tel. #: 905-829-1570, Fax. #: 905-829-8050, Email: [vic@ultratech-labs.com](mailto:vic@ultratech-labs.com), Website: <http://www.ultratech-labs.com>

File #: ICOM-091F87  
 November 8, 2004

All test results contained in this engineering test report are traceable to National Institute of Standards and Technology (NIST)

Plot 2:  
Occupied Bandwidth  
Carrier Frequency: 127.050 MHz  
Power: 1.5 W

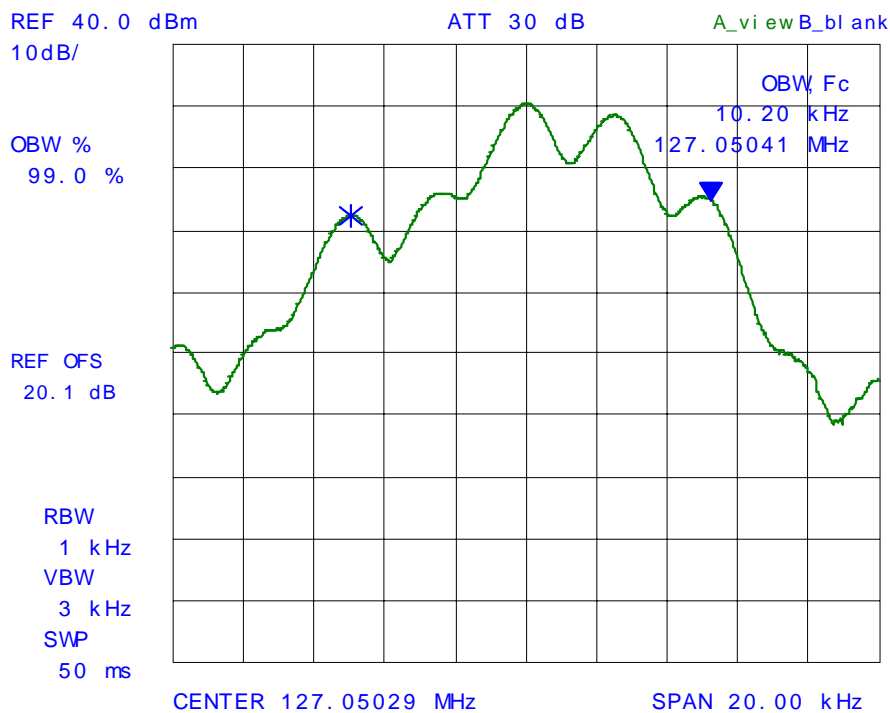

**ULTRATECH GROUP OF LABS**

3000 Bristol Circle, Oakville, Ontario, Canada L6H 6G4  
Tel. #: 905-829-1570, Fax. #: 905-829-8050, Email: [vic@ultratech-labs.com](mailto:vic@ultratech-labs.com), Website: <http://www.ultratech-labs.com>

File #: ICOM-091F87  
November 8, 2004

All test results contained in this engineering test report are traceable to National Institute of Standards and Technology (NIST)

Plot 3:  
Occupied Bandwidth  
Carrier Frequency: 136.975 MHz  
Power: 1.5 W

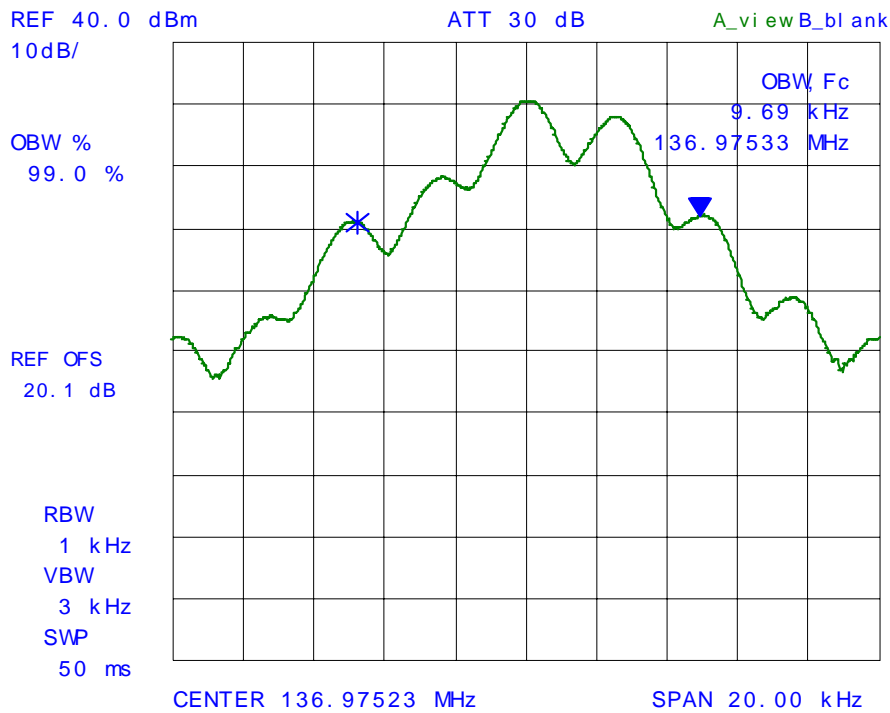

**ULTRATECH GROUP OF LABS**

3000 Bristol Circle, Oakville, Ontario, Canada L6H 6G4  
Tel. #: 905-829-1570, Fax. #: 905-829-8050, Email: [vic@ultratech-labs.com](mailto:vic@ultratech-labs.com), Website: <http://www.ultratech-labs.com>

File #: ICOM-091F87  
November 8, 2004

All test results contained in this engineering test report are traceable to National Institute of Standards and Technology (NIST)

6.8.5.2. Emission Limitations

Plot # 4:  
Emission Limitation  
Carrier Frequency: 118.000 MHz  
Power: 1.5 W

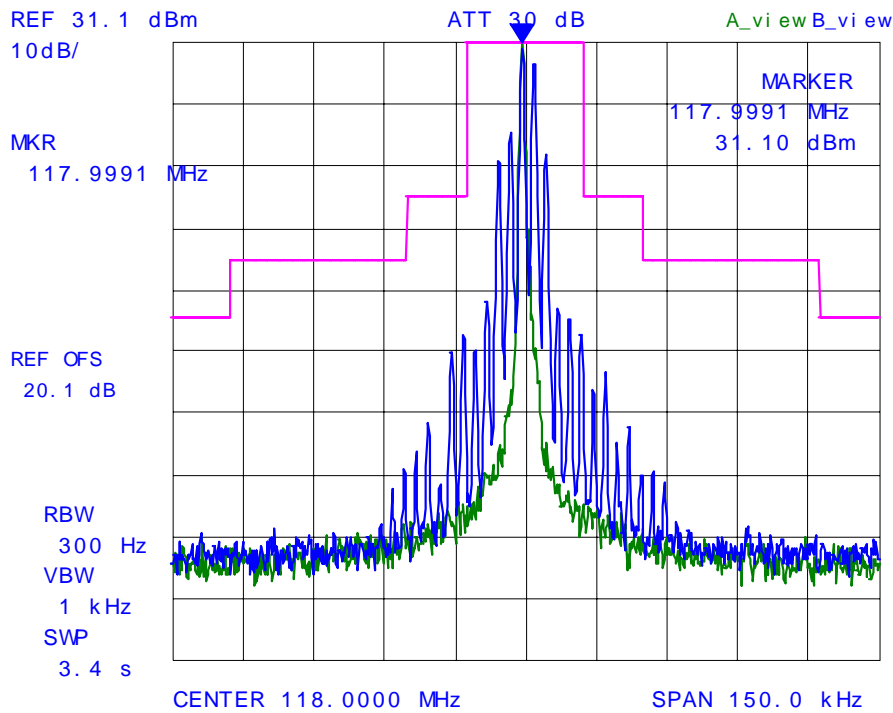

ULTRATECH GROUP OF LABS

3000 Bristol Circle, Oakville, Ontario, Canada L6H 6G4  
Tel. #: 905-829-1570, Fax. #: 905-829-8050, Email: [vic@ultratech-labs.com](mailto:vic@ultratech-labs.com), Website: <http://www.ultratech-labs.com>

File #: ICOM-091F87

November 8, 2004

All test results contained in this engineering test report are traceable to National Institute of Standards and Technology (NIST)

Plot # 5:  
Emission Limitation  
Carrier Frequency: 127.050 MHz  
Power: 1.5 W

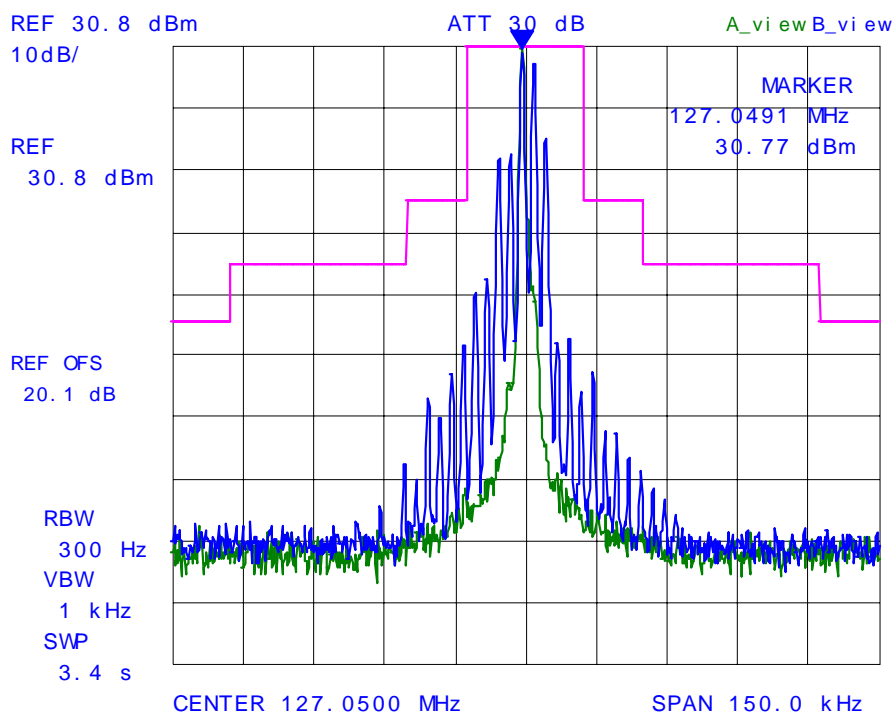

**ULTRATECH GROUP OF LABS**

3000 Bristol Circle, Oakville, Ontario, Canada L6H 6G4  
Tel. #: 905-829-1570, Fax. #: 905-829-8050, Email: [vic@ultratech-labs.com](mailto:vic@ultratech-labs.com), Website: <http://www.ultratech-labs.com>

File #: ICOM-091F87  
November 8, 2004

All test results contained in this engineering test report are traceable to National Institute of Standards and Technology (NIST)



Plot # 6:  
Emission Limitation  
Carrier Frequency: 136.975 MHz  
Power: 1.5 W

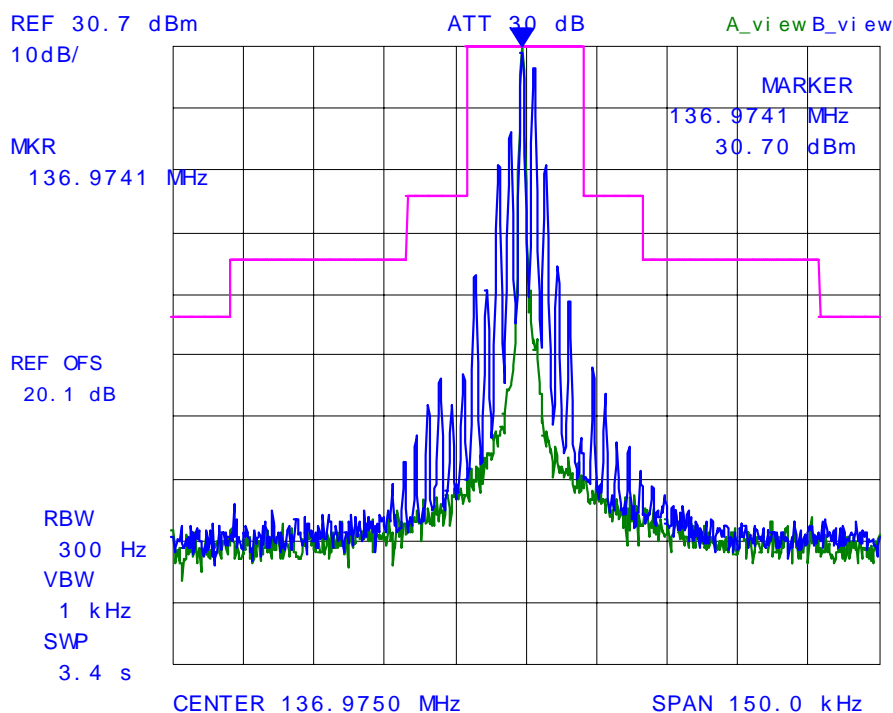

**ULTRATECH GROUP OF LABS**

3000 Bristol Circle, Oakville, Ontario, Canada L6H 6G4  
Tel. #: 905-829-1570, Fax. #: 905-829-8050, Email: [vic@ultratech-labs.com](mailto:vic@ultratech-labs.com), Website: <http://www.ultratech-labs.com>

File #: ICOM-091F87  
November 8, 2004

All test results contained in this engineering test report are traceable to National Institute of Standards and Technology (NIST)

## 6.9. SPURIOUS EMISSIONS AT ANTENNA TERMINAL [§§ 2.1051, 87.139]

### 6.9.1. Limits

§ 87.139(a)(3) - When the frequency is removed from the assigned frequency by more than 250 percent of the authorized bandwidth the attenuation for aircraft station transmitters must be at least 40 dB; and the attenuation for aeronautical station transmitters must be at least  $43 + 10 \log_{10} pY$  dB.

### 6.9.2. Method of Measurements

Refer to Exhibit 8 Section 8.5 of this report for measurement details

### 6.9.3. Test Equipment List

Test Instruments	Manufacturer	Model No.	Serial No.	Frequency Range
Spectrum Analyzer	Advantest	R3271	15050203	100Hz-26.5GHz
Radio Communication Test Set	Marconi Instruments	2955	132037/226	AF SG 20Hz-20KHz
Attenuator	Weinschel	23-20-34	BH7876	DC-18GHz 10W
High Pass Filter	Mini-Circuit	SHP-230	9027 12	Cut of Frequency 230MHz

### 6.9.4. Test Arrangement

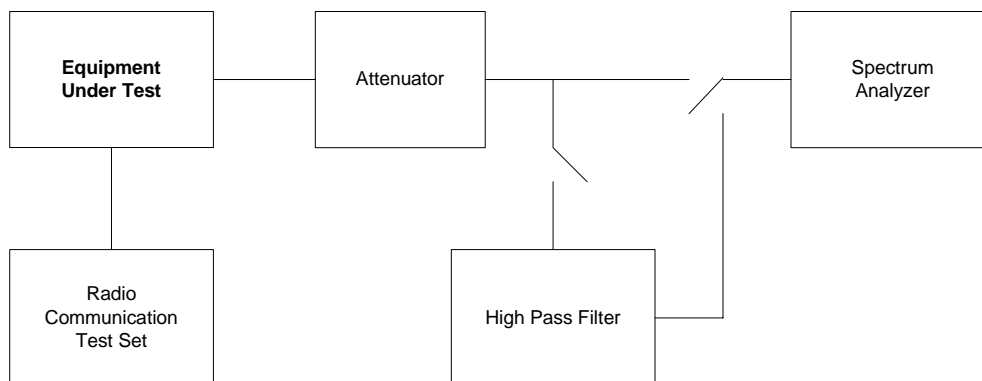

### 6.9.5. Test Data

Plot # 7:  
Spurious Emissions at Antenna Terminals  
Carrier Frequency: 118.000 MHz  
Power: 1.5 W

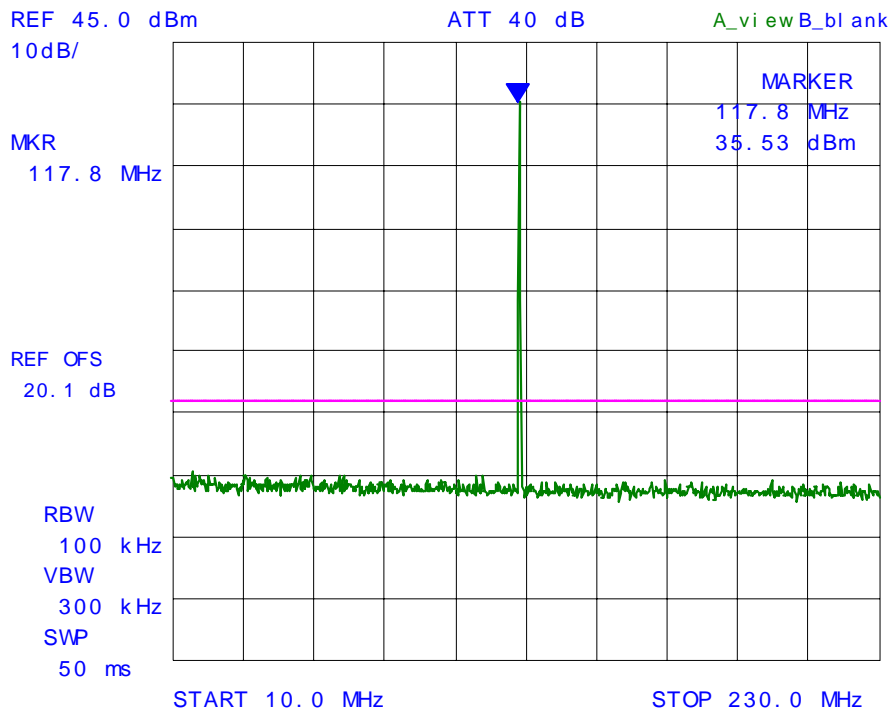

Plot # 8:  
Spurious Emissions at Antenna Terminals  
Carrier Frequency: 118.000 MHz  
Power: 1.5 W

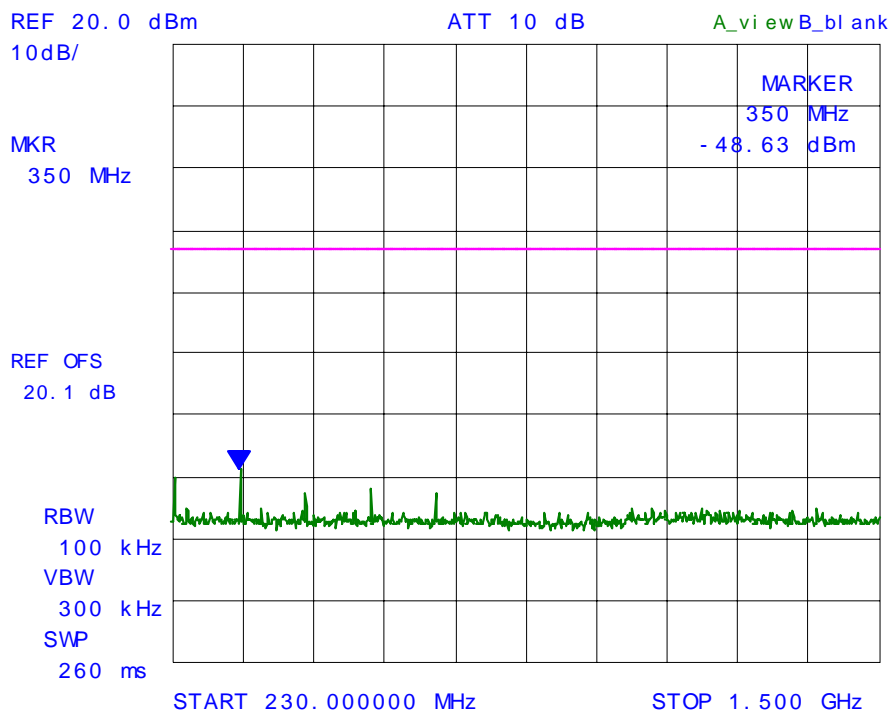

**ULTRATECH GROUP OF LABS**

3000 Bristol Circle, Oakville, Ontario, Canada L6H 6G4  
Tel. #: 905-829-1570, Fax. #: 905-829-8050, Email: [vic@ultratech-labs.com](mailto:vic@ultratech-labs.com), Website: <http://www.ultratech-labs.com>

File #: ICOM-091F87  
November 8, 2004

All test results contained in this engineering test report are traceable to National Institute of Standards and Technology (NIST)

Plot # 9:  
Spurious Emissions at Antenna Terminals  
Carrier Frequency: 127.050 MHz  
Power: 1.5 W

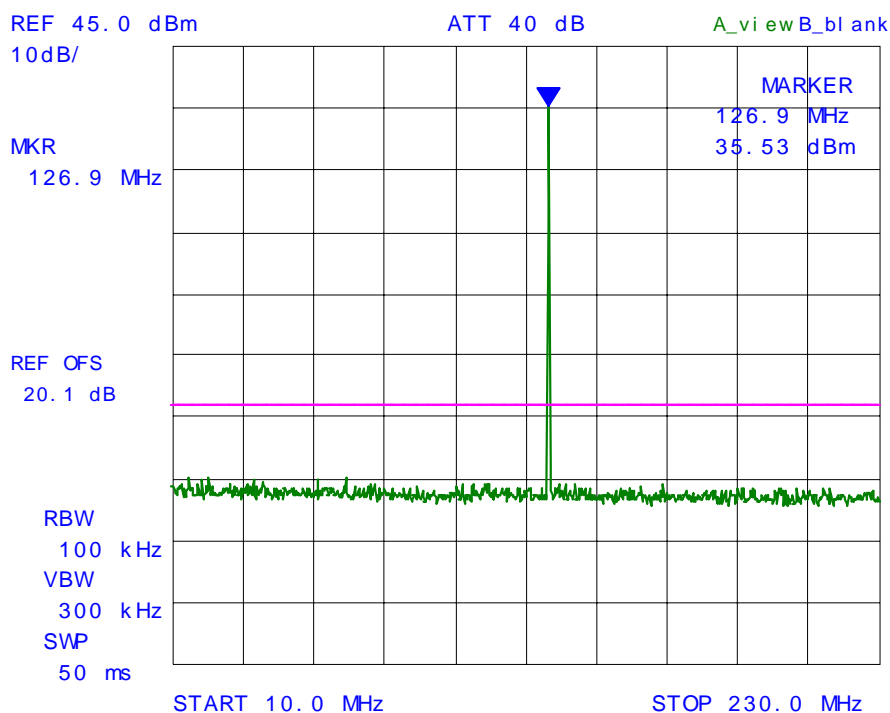

**ULTRATECH GROUP OF LABS**

3000 Bristol Circle, Oakville, Ontario, Canada L6H 6G4  
Tel. #: 905-829-1570, Fax. #: 905-829-8050, Email: [vic@ultratech-labs.com](mailto:vic@ultratech-labs.com), Website: <http://www.ultratech-labs.com>

File #: ICOM-091F87  
November 8, 2004

All test results contained in this engineering test report are traceable to National Institute of Standards and Technology (NIST)

Plot # 10:  
Spurious Emissions at Antenna Terminals  
Carrier Frequency: 127.050 MHz  
Power: 1.5 W

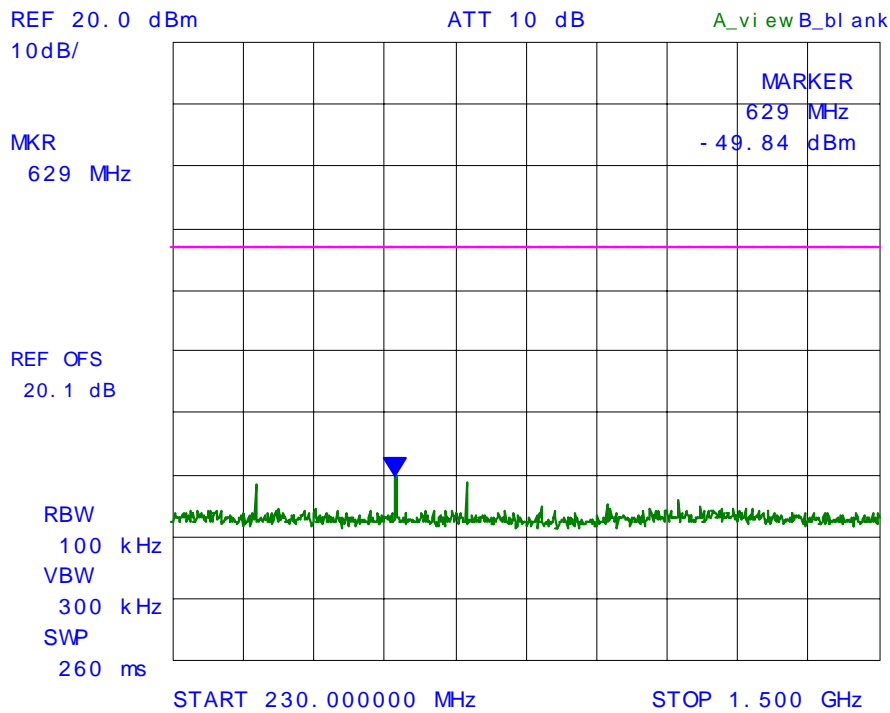

**ULTRATECH GROUP OF LABS**

3000 Bristol Circle, Oakville, Ontario, Canada L6H 6G4  
Tel. #: 905-829-1570, Fax. #: 905-829-8050, Email: [vic@ultratech-labs.com](mailto:vic@ultratech-labs.com), Website: <http://www.ultratech-labs.com>

File #: ICOM-091F87  
November 8, 2004

All test results contained in this engineering test report are traceable to National Institute of Standards and Technology (NIST)

Plot # 11:  
Spurious Emissions at Antenna Terminals  
Carrier Frequency: 136.975 MHz  
Power: 1.5 W

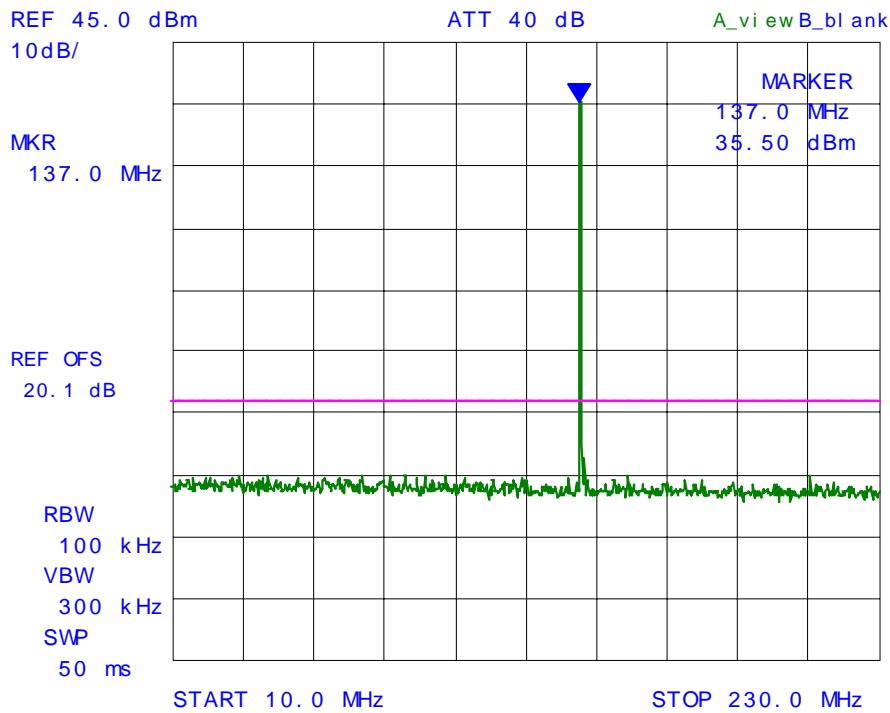

**ULTRATECH GROUP OF LABS**

3000 Bristol Circle, Oakville, Ontario, Canada L6H 6G4  
Tel. #: 905-829-1570, Fax. #: 905-829-8050, Email: [vic@ultratech-labs.com](mailto:vic@ultratech-labs.com), Website: <http://www.ultratech-labs.com>

File #: ICOM-091F87  
November 8, 2004

All test results contained in this engineering test report are traceable to National Institute of Standards and Technology (NIST)

Plot # 12:  
Spurious Emissions at Antenna Terminals  
Carrier Frequency: 136.975 MHz  
Power: 1.5 W

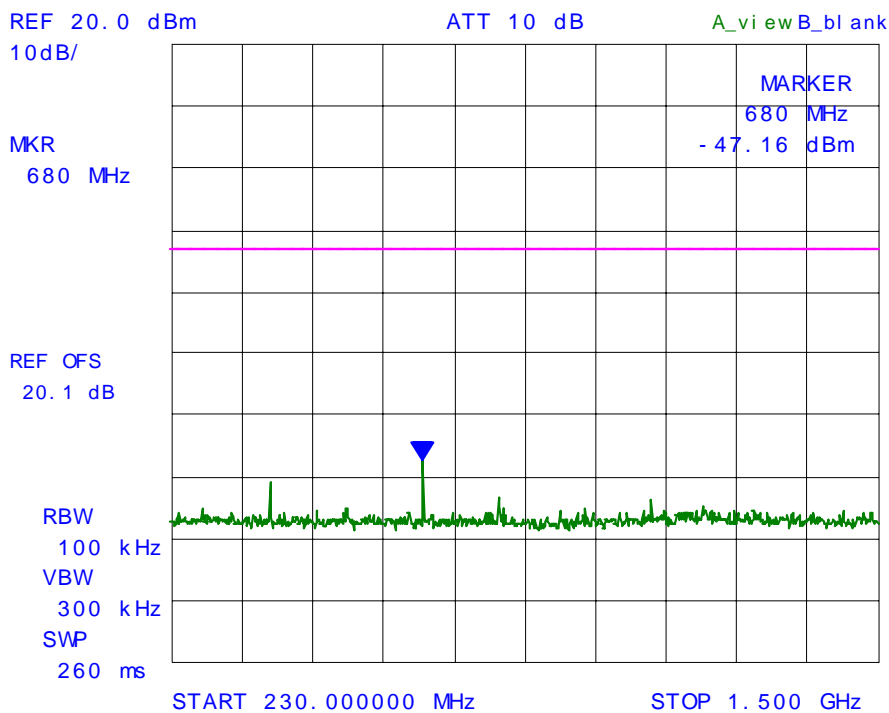

**ULTRATECH GROUP OF LABS**

3000 Bristol Circle, Oakville, Ontario, Canada L6H 6G4  
Tel. #: 905-829-1570, Fax. #: 905-829-8050, Email: [vic@ultratech-labs.com](mailto:vic@ultratech-labs.com), Website: <http://www.ultratech-labs.com>

File #: ICOM-091F87  
November 8, 2004

All test results contained in this engineering test report are traceable to National Institute of Standards and Technology (NIST)



## 6.10. FIELD STRENGTH OF SPURIOUS EMISSIONS [§§ 2.1053, 87.139]

### 6.10.1. Limits @ FCC 87.139

§ 87.139(a)(3) - When the frequency is removed from the assigned frequency by more than 250 percent of the authorized bandwidth the attenuation for aircraft station transmitters must be at least 40 dB; and the attenuation for aeronautical station transmitters must be at least 43 + 10 log<sub>10</sub> pY dB.

### 6.10.2. Method of Measurements

The spurious/harmonic ERP measurements are using substitution method specified in Exhibit 8, Section 8.2 of this report and its value in dBc is calculated as follows:

- (1) If the transmitter's antenna is an integral part of the EUT, the ERP is measured using substitution method.
- (2) If the transmitter's antenna is non-integral and diverse, the lowest ERP of the carrier with 0 dBi antenna gain is used for calculation of the spurious/harmonic emissions in dBc:  
Lowest ERP of the carrier = EIRP – 2.15 dB = P<sub>c</sub> + G - 2.15 dB = P<sub>c</sub> dBm (conducted) + 0 dBi – 2.15 dB
- (3) Spurious /harmonic emissions levels expressed in dBc (dB below carrier) are as follows:

$$\text{ERP of spurious/harmonic (dBc)} = \text{ERP of carrier (dBm)} - \text{ERP of spurious/harmonic emission (dBm)}$$

### 6.10.3. Test Equipment List

Test Instruments	Manufacturer	Model No.	Serial No.	Frequency Range
Spectrum Analyzer/ EMI Receiver	Hewlett Packard	HP 8546A	...	9 kHz to 5.6 GHz with built-in 30 dB Gain Pre-selector, QP, Average & Peak Detectors.
RF Amplifier	Com-Power	PA-102		1 MHz to 1 GHz, 30 dB gain nominal
Microwave Amplifier	Hewlett Packard	HP 83017A		1 GHz to 26.5 GHz, 30 dB nominal
Biconilog Antenna	EMCO	3142	10005	30 MHz to 2 GHz
Dipole Antenna	EMCO	3121C	8907-434	30 GHz – 1 GHz
Dipole Antenna	EMCO	3121C	8907-440	30 GHz – 1 GHz
Horn Antenna	EMCO	3155	9701-5061	1 GHz – 18 GHz
Horn Antenna	EMCO	3155	9911-5955	1 GHz – 18 GHz
RF Signal Generator	Hewlett Packard	HP 83752B	3610A00457	0.01 – 20 GHz

## ULTRATECH GROUP OF LABS

3000 Bristol Circle, Oakville, Ontario, Canada L6H 6G4  
Tel. #: 905-829-1570, Fax. #: 905-829-8050, Email: [vic@ultratech-labs.com](mailto:vic@ultratech-labs.com), Website: <http://www.ultratech-labs.com>

File #: ICOM-091F87  
November 8, 2004

All test results contained in this engineering test report are traceable to National Institute of Standards and Technology (NIST)

#### 6.10.4. Test Data

##### 6.10.4.1. Near Lowest Frequency (118.000 MHz)

Fundamental Frequency: 118.00 MHz  
RF Output Power: 1.5 W  
Test Frequency Range: 30 MHz – 1.5 GHz

---

All emissions are more than 20 dB below the limit.

##### 6.10.4.2. Near Middle Frequency (127.050 MHz)

Fundamental Frequency: 127.050 MHz  
RF Output Power: 1.5 W  
Test Frequency Range: 30 MHz – 1.5 GHz

---

All emissions are more than 20 dB below the limit.

##### 6.10.4.3. Near Highest Frequency (136.975 MHz)

Fundamental Frequency: 136.975 MHz  
RF Output Power: 1.5 W  
Test Frequency Range: 30 MHz – 1.5 GHz

---

All emissions are more than 20 dB below the limit.

## 6.11. FREQUENCY STABILITY [§§ 2.1055 & 87.133]

### 6.11.1. Limits

The carrier frequency of each station must be maintained within the tolerance in the following table:

Frequency band (lower limit exclusive, upper limit inclusive), and categories of station	Tolerance (ppm)
Band - 108 to 137 MHz: Aircraft and other mobile stations in the Aviation Services.	*30

\* For emissions G1D and G7D, the tolerance is 5 parts per 10<sup>6</sup>.

### 6.11.2. Method of Measurements

Refer to Exhibit 8, Section 8.3 of this report for measurement details

### 6.11.3. Test Equipment List

Test Instruments	Manufacturer	Model No.	Serial No.	Frequency Range
EIP Microwave Frequency Counter	EIP	545A	2683	10Hz-18GHz
Attenuator	Weinschel	23-20-34	BH7876	DC-18GHz 10W
Temperature & Humidity Chamber	Tenney	T5	9723B	-40° to +60° C range

### 6.11.4. Test Arrangement

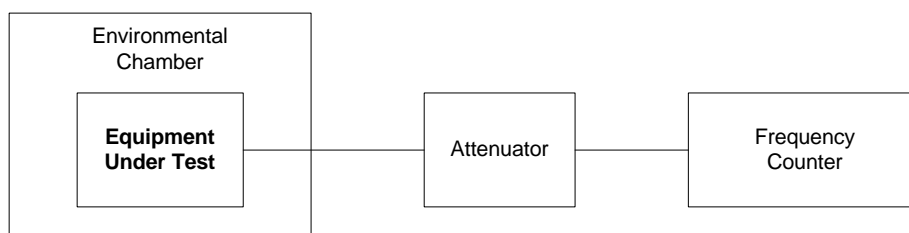

**6.11.5. Test Data**

<b>Product Name:</b>	VHF Air Band Transceiver
<b>Model No.:</b>	IC-A24 / IC-A6
<b>Center Frequency:</b>	118.000 MHz
<b>Full Power Level:</b>	1.5 W
<b>Frequency Tolerance Limit:</b>	30 ppm or 3540 Hz (Manufacturer rating: 5 ppm)
<b>Max. Frequency Tolerance Measured:</b>	0.47 ppm or +55 Hz
<b>Input Voltage Rating:</b>	7.2 VDC

<b>CENTER FREQUENCY &amp; RF POWER OUTPUT VARIATION</b>			
<b>Ambient Temperature (°C)</b>	<b>Supply Voltage (Nominal) 7.2 Volts</b>	<b>Supply Voltage (85% of Nominal) 6.12 Volts</b>	<b>Supply Voltage (115% of Nominal) 8.28 Volts</b>
	<b>Hz</b>	<b>Hz</b>	<b>Hz</b>
-30	+19	N/A	N/A
-20	+19	N/A	N/A
-10	+21	N/A	N/A
0	+28	N/A	N/A
+10	+27	N/A	N/A
+20	+18	+15	+16
+30	+31	N/A	N/A
+40	+30	N/A	N/A
+50	+55	N/A	N/A
+60	+45	N/A	N/A

**RF Output Power Versus Input Voltage at Room Temperature**

Input Voltage (Vdc)	Input Current (A)	RF Output Power (dBm)
8.5	1.165	11.79
8.4	1.168	11.75
8.2	1.162	11.75
8.0	1.162	11.75
7.8	1.166	11.75
7.6	1.169	11.76
7.4	1.165	11.75
7.2	1.160	11.76
7.0	1.165	11.75
6.8	1.146	11.75
6.6	1.121	11.71
6.4	1.111	11.68
6.2	1.099	11.67
6.1	*	*

\* Device shuts down.

## EXHIBIT 7. MEASUREMENT UNCERTAINTY

The measurement uncertainties stated were calculated in accordance with the requirements of NIST Technical Note 1297 and NIS 81 (1994)

### 7.1. RADIATED EMISSION MEASUREMENT UNCERTAINTY

CONTRIBUTION (Radiated Emissions)	PROBABILITY DISTRIBUTION	UNCERTAINTY (+ dB)	
		3 m	10 m
Antenna Factor Calibration	Normal (k=2)	$\pm 1.0$	$\pm 1.0$
Cable Loss Calibration	Normal (k=2)	$\pm 0.3$	$\pm 0.5$
EMI Receiver specification	Rectangular	$\pm 1.5$	$\pm 1.5$
Antenna Directivit	Rectangular	+0.5	+0.5
Antenna factor variation with height	Rectangular	$\pm 2.0$	$\pm 0.5$
Antenna phase center variation	Rectangular	0.0	$\pm 0.2$
Antenna factor frequency interpolation	Rectangular	$\pm 0.25$	$\pm 0.25$
Measurement distance variation	Rectangular	$\pm 0.6$	$\pm 0.4$
Site imperfections	Rectangular	$\pm 2.0$	$\pm 2.0$
Mismatch: Receiver VRC $\Gamma_1 = 0.2$ Antenna VRC $\Gamma_R = 0.67(\text{Bi}) 0.3 (\text{Lp})$ Uncertainty limits $20\text{Log}(1 \pm \Gamma_1 \Gamma_R)$	U-Shaped	+1.1 -1.25	$\pm 0.5$
System repeatability	Std. Deviation	$\pm 0.5$	$\pm 0.5$
Repeatability of EUT		-	-
Combined standard uncertainty	Normal	+2.19 / -2.21	+1.74 / -1.72
Expanded uncertainty U	Normal (k=2)	+4.38 / -4.42	+3.48 / -3.44

Calculation for maximum uncertainty when 3m biconical antenna including a factor of k = 2 is used:

$$U = 2u_c(y) = 2x(+2.19) = +4.38 \text{ dB} \quad \text{And} \quad U = 2u_c(y) = 2x(-2.21) = -4.42 \text{ dB}$$

## EXHIBIT 8. MEASUREMENT METHODS

### 8.1. CONDUCTED POWER MEASUREMENTS

- The following shall be applied to the combination(s) of the radio device and its intended antenna(e).
- If the RF level is user adjustable, all measurements shall be made with the highest power level available to the user for that combination.
- The following method of measurement shall apply to both conducted and radiated measurements.
- The radiated measurements are performed at the Ultratech Calibrated Open Field Test Site.
- The measurement shall be performed using normal operation of the equipment with modulation.

Test procedure shall be as follows:

**Step 1:** Duty Cycle measurements if the transmitter's transmission is transient

- Using a EMI Receiver with the frequency span set to 0 Hz and the sweep time set at a suitable value to capture the envelope peaks and the duty cycle of the transmitter output signal;
- The duty cycle of the transmitter,  $x = T_x \text{ on} / (T_x \text{ on} + T_x \text{ off})$  with  $0 < x < 1$ , is measure and recorded in the test report. For the purpose of testing, the equipment shall be operated with a duty cycle that is equal or more than 0.1.

**Step 2:** Calculation of Average EIRP. See Figure 1

- The average output power of the transmitter shall be determined using a wideband, calibrated RF average power meter with the power sensor with an integration period that exceeds the repetition period of the transmitter by a factor 5 or more. The observed value shall be recorded as "A" (in dBm);
- The e.i.r.p. shall be calculated from the above measured power output "A", the observed duty cycle x, and the applicable antenna assembly gain "G" in dBi, according to the formula:

$$\text{EIRP} = \text{A} + \text{G} + 10\log(1/x)$$

{ X = 1 for continuous transmission =>  $10\log(1/x) = 0 \text{ dB}$  }

**Figure 1.**

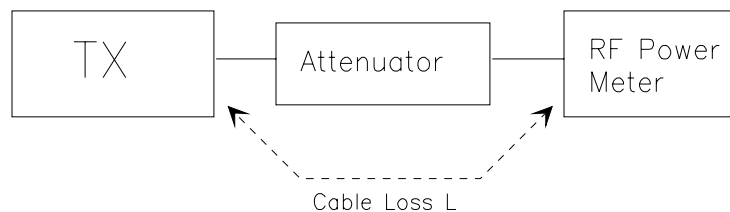

## 8.2. RADIATED POWER MEASUREMENTS (ERP & EIRP) USING SUBSTITUTION METHOD

### 8.2.1. Maximizing RF Emission Level (E-Field)

- (a) The measurements was performed with full rf output power and modulation.
- (b) Test was performed at listed 3m open area test site (listed with FCC, IC, ITI, NVLAP, ACA & VCCI).
- (c) The transmitter under test was placed at the specified height on a non-conducting turntable (80 cm height)
- (d) The BICONILOG antenna (20 MHz to 1 GHz) or HORN antenna (1 GHz to 18 GHz) was used for measuring.
- (e) Load an appropriate correction factors file in EMI Receiver for correcting the field strength reading level

Total Correction Factor recorded in the EMI Receiver = Cable Loss + Antenna Factor  
 $E \text{ (dBuV/m)} = \text{Reading (dBuV)} + \text{Total Correction Factor (dB/m)}$

- (f) Set the EMI Receiver and #2 as follows:

Center Frequency: test frequency  
Resolution BW: 100 kHz  
Video BW: same  
Detector Mode: positive  
Average: off  
Span: 3 x the signal bandwidth

- (g) The test antenna was lowered or raised from 1 to 4 meters until the maximum signal level was detected.
- (h) The transmitter was rotated through 360° about a vertical axis until a higher maximum signal was received.
- (i) The test antenna was lowered or raised again from 1 to 4 meters until a maximum was obtained. This level was recorded.
- (j) The recorded reading was corrected to the true field strength level by adding the antenna factor, cable loss and subtracting the pre-amplifier gain.
- (k) The above steps were repeated with both transmitters' antenna and test receiving antenna placed in vertical and horizontal polarization. Both readings with the antennas placed in vertical and horizontal polarization shall be recorded.
- (l) Repeat for all different test signal frequencies



### 8.2.2. Measuring the EIRP of Spurious/Harmonic Emissions Using Substitution Method

(a) Set the EMI Receiver (for measuring E-Field) and Receiver #2 (for measuring EIRP) as follows:

Center Frequency: equal to the signal source  
Resolution BW: 10 kHz  
Video BW: same  
Detector Mode: positive  
Average: off  
Span: 3 x the signal bandwidth

(b) Load an appropriate correction factors file in EMI Receiver for correcting the field strength reading level

Total Correction Factor recorded in the EMI Receiver = Cable Loss + Antenna Factor  
 $E \text{ (dBuV/m)} = \text{Reading (dBuV)} + \text{Total Correction Factor (dB/m)}$

(c) Select the frequency and E-field levels obtained in the Section 8.2.1 for ERP/EIRP measurements.

(d) Substitute the EUT by a signal generator and one of the following transmitting antenna (substitution antenna):

- ◆ DIPOLE antenna for frequency from 30-1000 MHz or
- ◆ HORN antenna for frequency above 1 GHz }

(e) Mount the transmitting antenna at 1.5 meter high from the ground plane.

(f) Use one of the following antenna as a receiving antenna:

- ◆ DIPOLE antenna for frequency from 30-1000 MHz or
- ◆ HORN antenna for frequency above 1 GHz }

(g) If the DIPOLE antenna is used, tune it's elements to the frequency as specified in the calibration manual.

(h) Adjust both transmitting and receiving antenna in a VERTICAL polarization.

(i) Tune the EMI Receivers to the test frequency.

(j) Lower or raise the test antenna from 1 to 4 meters until the maximum signal level was detected.

(k) The transmitter was rotated through 360° about a vertical axis until a higher maximum signal was received.

(l) Lower or raise the test antenna from 1 to 4 meters until the maximum signal level was detected.

(m) Adjust input signal to the substitution antenna until an equal or a known related level to that detected from the transmitter was obtained in the test receiver.

(n) Record the power level read from the Average Power Meter and calculate the ERP/EIRP as follows:

$$P = P1 - L1 = (P2 + L2) - L1 = P3 + A + L2 - L1$$

$$EIRP = P + G1 = P3 + L2 - L1 + A + G1$$

$$ERP = EIRP - 2.15 \text{ dB}$$

$$\text{Total Correction factor in EMI Receiver \# 2} = L2 - L1 + G1$$

Where: P: Actual RF Power fed into the substitution antenna port after corrected.

P1: Power output from the signal generator

P2: Power measured at attenuator A input

P3: Power reading on the Average Power Meter

EIRP: EIRP after correction

ERP: ERP after correction

(o) Adjust both transmitting and receiving antenna in a HORIZONTAL polarization, then repeat step (k) to (o)

(p) Repeat step (d) to (o) for different test frequency

(q) Repeat steps (c) to (j) with the substitution antenna oriented in horizontal polarization.

(r) Actual gain of the EUT's antenna is the difference of the measured EIRP and measured RF power at the RF port. Correct the antenna gain if necessary.

Figure 2

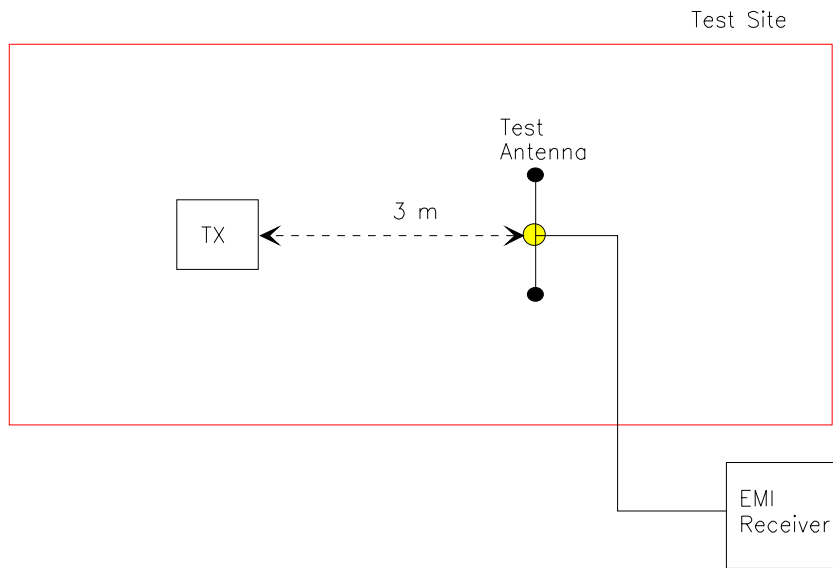
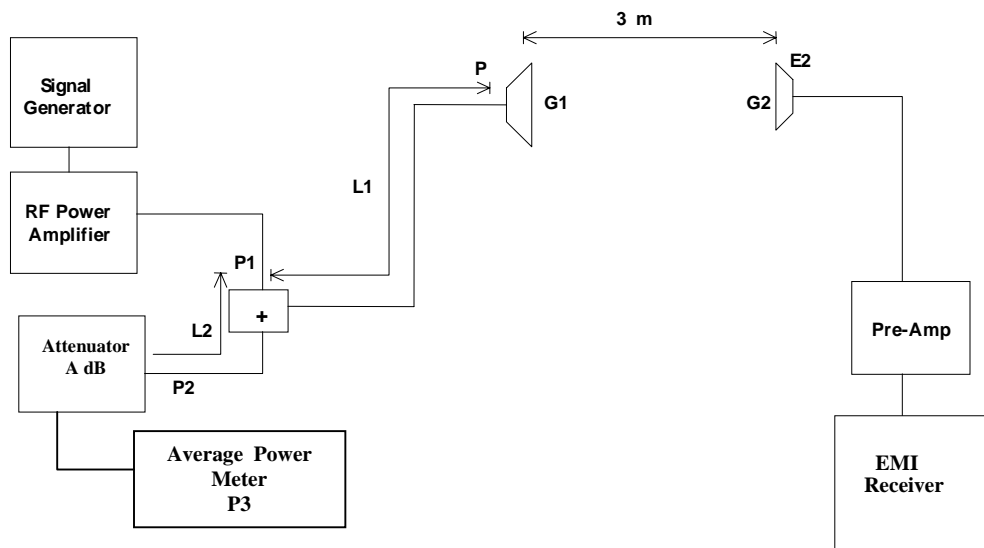

Figure 3



### 8.3. FREQUENCY STABILITY

Refer to FCC @ 2.1055.

- (a) The frequency stability shall be measured with variation of ambient temperature as follows: From -30 to +50 centigrade except that specified in subparagraph (2) & (3) of this paragraph.
- (b) Frequency measurements shall be made at extremes of the specified temperature range and at intervals of not more than 10 centigrade through the range. A period of time sufficient to stabilize all of the components of the oscillator circuit at each temperature level shall be allowed prior to frequency measurement. The short-term transient effects on the frequency of the transmitter due to keying (except for broadcast transmitters) and any heating element cycling normally occurring at each ambient temperature level also shall be shown. Only the portion or portions of the transmitter containing the frequency determining and stability circuitry need be subjected to the temperature variation test.
- (d) The frequency stability supply shall be measured with variation of primary supply voltage as follows:
  - (1) Vary primary supply voltage from 85 to 115 percent of the nominal value for other than hand carried battery equipment.
  - (2) For hand carried, battery powered equipment, reduce primary supply voltage to the battery operating end point which shall be specified by the manufacturer.
  - (3) The supply voltage shall be measured at the input to the cable normally provide with the equipment, or at the power supply terminals if cables are not normally provided. Effects on frequency of transmitter keying (except for broadcast transmitters) and any heating element cycling at the nominal supply voltage and at each extreme also shall be shown.
- (e) When deemed necessary, the Commission may require tests of frequency stability under conditions in addition to those specifically set out in paragraphs (a), (b), (c) and (d) of this section. (For example, measurements showing the effect of proximity to large metal objects, or of various types of antennas, may be required for portable equipment).

## 8.4. EMISSION LIMITATIONS

**Voice or Digital Modulation Through a Voice Input Port @ 2.1049(c)(i):**- The transmitter was modulated by a 2.5 KHz tone signal at an input level 16 dB greater than that required to produce 50% modulation (e.g.:  $\pm 2.5$  KHz peak deviation at 1 KHz modulating frequency). The input level was established at the frequency of maximum response of the audio modulating circuit.

**Digital Modulation Through a Data Input Port @ 2.1049(h):**- Transmitters employing digital modulation techniques - when modulated by an input signal such that its amplitude and symbol rate represent the maximum rated conditions under which the equipment will be operated. The signal shall be applied through any filter networks, pseudo-random generators or other devices required in normal service. Additionally, the Emission Masks shall be shown for operation with any devices used for modifying the spectrum when such devices are operational at the discretion of the user.

The following EMI Receiver bandwidth shall be used for measurement of Emission Mask/Out-of-Band Emission Measurements:

- (1) For 25 kHz Channel Spacing: RBW = 300 Hz
- (2) For 12.5 kHz or 6.25 kHz Channel Spacings: RBW = 100 Hz

The all cases the Video Bandwidth shall be equal or greater than the measuring bandwidth.

## 8.5. SPURIOUS EMISSIONS (CONDUCTED)

With transmitter modulation characteristics described in Out-of-Band Emissions measurements @ 2.1049, the transmitter spurious and harmonic emissions were scanned. The spurious and harmonic emissions were measured with the EMI Receiver controls set as RBW = 30 kHz minimum , VBW  $\geq$  RBW and SWEEP TIME = AUTO). The transmitter was operated at a full rated power output, and modulated as follows:

**FCC CFR 47, Para. 2.1057 - Frequency spectrum to be investigated:-** The spectrum was investigated from the lowest radio generated in the equipment up to at least the 10<sup>th</sup> harmonic of the carrier frequency or to the highest frequency practicable in the present state of the art of measuring techniques, whichever is lower. Particular attention should be paid to harmonics and subharmonics of the carrier frequency. Radiation at the frequencies of multiplier stages should be checked. The amplitude of spurious emissions which are attenuated more than 20 dB below the permissible value need not be reported.

**FCC CFR 47, Para. 2.1051 - Spurious Emissions at Antenna Terminal:-** The radio frequency voltage or powers generated within the equipment and appearing on a spurious frequency shall be checked at the equipment output terminals when properly loaded with a suitable artificial antenna. Curves or equivalent data shall show the magnitude of the harmonic and other spurious emission that can be detected when the equipment is operated under the conditions specified in 2.1049 as appropriate. The magnitude of spurious emissions which are attenuated more than 20 dB below the permissible value need not be specified.