

ENGINEERING TEST REPORT



Marine Radar
Model(s): MXR-5000T

Applicant:

ICOM Incorporated
1-1-32, Kamiminami
Hirano-ku, Osaka
Japan, 547-0003

Tested in Accordance With

Federal Communications Commission (FCC)
CFR 47, Part 15, Subpart B
Class A Digital Devices

UltraTech's File No.: ICOM-254F15B

This Test report is Issued under the Authority of
Tri M. Luu, BSc
Vice President of Engineering
UltraTech Group of Labs

Date: November 22, 2010

Report Prepared by: Dan Huynh

Tested by: Willian Truong

Issued Date: November 22, 2010

Test Dates: November 2, 2010

- *The results in this Test Report apply only to the sample(s) tested, and the sample tested is randomly selected.*
- *This report must not be used by the client to claim product endorsement by NVLAP or any agency of the US Government.*

UltraTech

3000 Bristol Circle, Oakville, Ontario, Canada, L6H 6G4
Tel.: (905) 829-1570 Fax.: (905) 829-8050
Website: www.ultratech-labs.com, Email: vic@ultratech-labs.com, Email: tri@ultratech-labs.com

FCC

91038



1309



Approved Test Facility

46390-2049



NvLap Lab Code 200093-0



SL2-IN-E-1119R



Korea KCC-RRL
CA2049

TABLE OF CONTENTS

EXHIBIT 1.	INTRODUCTION.....	1
1.1.	SCOPE	1
1.2.	RELATED SUBMITTAL(S)/GRANT(S).....	1
1.3.	NORMATIVE REFERENCES	1
EXHIBIT 2.	PERFORMANCE ASSESSMENT.....	2
2.1.	CLIENT INFORMATION	2
2.2.	EQUIPMENT UNDER TEST (EUT) INFORMATION	2
2.3.	LIST OF EUT'S PORTS	3
2.4.	ANCILLARY EQUIPMENT	3
EXHIBIT 3.	EUT OPERATING CONDITIONS AND CONFIGURATIONS DURING TESTS.....	5
3.1.	CLIMATE TEST CONDITIONS	5
3.2.	OPERATIONAL TEST CONDITIONS & ARRANGEMENT FOR TEST SIGNALS	5
3.3.	BLOCK DIAGRAM OF TEST SETUP FOR RADIATED EMISSION MEASUREMENTS.....	5
3.4.	PHOTOGRAPHS OF TEST SETUP FOR RADIATED EMISSION MEASUREMENTS	6
EXHIBIT 4.	SUMMARY OF TEST RESULTS.....	9
4.1.	LOCATION OF TESTS.....	9
4.2.	APPLICABILITY & SUMMARY OF EMC EMISSION TEST RESULTS.....	9
4.3.	MODIFICATIONS REQUIRED FOR COMPLIANCE	9
4.4.	DEVIATION OF THE STANDARD TEST PROCEDURES.....	9
EXHIBIT 5.	MEASUREMENT DATA	10
5.1.	RADIATED EMISSIONS FROM UNINTENTIONAL RADIATORS (DIGITAL DEVICES) [47 CFR 15.109(A)]	10
EXHIBIT 6.	MEASUREMENT UNCERTAINTY	14
6.1.	LINE CONDUCTED EMISSION MEASUREMENT UNCERTAINTY (0.15-30 MHz)	14
6.2.	RADIATED EMISSION MEASUREMENT UNCERTAINTY	15
EXHIBIT 7.	LABELLING & FCC AUTHORIZATION REQUIREMENTS.....	16
7.1.	SECTION 15.19 - LABELLING REQUIREMENTS.....	16
7.2.	SECTION 15.21 - INFORMATION TO USER	16
7.3.	SECTION 15.105 - INFORMATION TO THE USER	17
7.4.	SECTION 2.902 – VERIFICATION.....	17
7.5.	SECTION 2.909 - RESPONSIBLE PARTY	18
7.6.	SECTION 2.945 – SAMPLING TESTS OF EQUIPMENT COMPLIANCE.....	18
7.7.	SECTION 2.946 – PENALTY FOR FAILURE TO PROVIDE TEST SAMPLES AND DATA	18
7.8.	SECTION 2.952 - LIMITATION ON VERIFICATION	18
7.9.	SECTION 2.953 - RESPONSIBILITY OF COMPLIANCE	19
7.10.	SECTION 2.954 - IDENTIFICATION.....	19
7.11.	SECTION 2.955 - RETENTION OF RECORDS	19
7.12.	SECTION 2.956 - FCC INSPECTION & SUBMISSION OF EQUIPMENT FOR TESTING	20

EXHIBIT 1. INTRODUCTION

1.1. SCOPE

Reference:	FCC Part 15, Subpart B, Sections 15.107 & 15.109
Title:	Telecommunication - Code of Federal Regulations, CFR 47, Part 15
Purpose of Test:	Verification Authorization for a Class A Unintentional Radiator.
Test Procedures:	Both conducted and radiated emissions measurements were conducted in accordance with American National Standards Institute ANSI C63.4 - American National Standard for Methods of Measurement of Radio-Noise Emissions from Low-Voltage Electrical and Electronic Equipment in the Range of 9 kHz to 40 GHz.
Environmental Classification:	Light-industry, Commercial & Industry

1.2. RELATED SUBMITTAL(S)/GRANT(S)

None.

1.3. NORMATIVE REFERENCES

Publication	Year	Title
CISPR 22 EN 55022	2008-09, Edition 6.0 2006	Information Technology Equipment - Radio Disturbance Characteristics - Limits and Methods of Measurement
ANSI C63.4	2003	American National Standard for Methods of Measurement of Radio-Noise Emissions from Low-Voltage Electrical and Electronic Equipment in the Range of 9 KHz to 40 GHz
CISPR 16-1-1 +A1 +A2	2006 2006 2007	Specification for radio disturbance and immunity measuring apparatus and methods. Part 1-1: Measuring Apparatus
CISPR 16-1-2 +A1: 2004 +A2: 2006	2003 2004 2006	Specification for radio disturbance and immunity measuring apparatus and methods. Part 1-2: Conducted disturbances
FCC 47 CFR 15	2009	Code of Federal Regulations – Telecommunication

EXHIBIT 2. PERFORMANCE ASSESSMENT

2.1. CLIENT INFORMATION

APPLICANT	
Name:	Icom Incorporated
Address:	1-1-32, Kamiminami, Hirano-ku, Osaka Japan, 547-0003
Contact Person:	Mr. Takayuki Watanabe Phone #: +81-66-793-5302 Fax #: +81-66-793-0013 Email Address: export@icom.co.jp

MANUFACTURER	
Name:	Icom Incorporated
Address:	1-1-32, Kamiminami,d Hirano-ku, Osaka Japan, 547-0003
Contact Person:	Mr. Takayuki Watanabe Phone #: +81-66-793-5302 Fax #: +81-66-793-0013 Email Address: export@icom.co.jp

2.2. EQUIPMENT UNDER TEST (EUT) INFORMATION

The following information (with the exception of the Date of Receipt) has been supplied by the applicant.

Brand Name:	ICOM Incorporated
Product Name:	Marine Radar
Model(s)*:	MXR-5000T
Serial Number:	Test sample
Type of Equipment:	Shipborne Radar
External Power Supply:	N/A
Oscillators' Frequency(ies):	60 MHz
Power input source:	12 V/ 24 V DC

2.3. LIST OF EUT’S PORTS

2.3.1. Marine Radar (MXR-5000T), Scanner Unit EX-2780

Port Number	EUT’s Port Description	Number of Identical Ports	Connector Type	Cable Type (Shielded/Non-shielded)
1	Scanner Connector	1	7 pin CMC	Shielded

2.3.2. Marine Radar (MXR-5000T), Radar Unit

Port Number	EUT’s Port Description	Number of Identical Ports	Connector Type	Cable Type (Shielded/Non-shielded)
1	DC Power Input / Ground Terminals	1	Terminal Block	Non-shielded
2	MarineCommander Connector	1	RJ-45	Shielded
3	Scanner Unit Connector	1	7 pin CMC	Shielded

2.4. ANCILLARY EQUIPMENT

The EUT was tested while connected to the following representative configuration of ancillary equipment necessary to exercise the ports during tests:

Ancillary Equipment # 1	
Description:	MarineCommander Marine Plotter
Brand Name:	Icom Inc.
Model Name or Number:	MXP-5000
Serial Number:	N/A
Cable Length & Type:	> 3 m, Shielded
Connected to EUT’s Port:	N/A

Ancillary Equipment # 2	
Description:	GPS Receiver
Brand Name:	Icom Inc.
Model Name or Number:	MXG-5000
Serial Number:	0000310
Cable Length & Type:	> 3 m, Shielded
Connected to EUT’s Port:	N/A

Ancillary Equipment # 3	
Description:	MarineCommander Display Unit
Brand Name:	Icom Inc.
Model Name or Number:	MXD-5000
Serial Number:	0000413
Cable Length & Type:	> 3 m, Shielded
Connected to EUT's Port:	N/A

Ancillary Equipment # 4	
Description:	Radar Unit
Brand Name:	Icom Inc.
Model Name or Number:	MXR-5000T
Serial Number:	0000204
Cable Length & Type:	> 3 m, Shielded
Connected to EUT's Port:	Circular Metal Connector

EXHIBIT 3. EUT OPERATING CONDITIONS AND CONFIGURATIONS DURING TESTS

3.1. CLIMATE TEST CONDITIONS

The climate conditions of the test environment are as follows:

Temperature:	21°C
Humidity:	51%
Pressure:	102 kPa
Power input source:	24 V DC

3.2. OPERATIONAL TEST CONDITIONS & ARRANGEMENT FOR TEST SIGNALS

The EUT was operating in standby mode during testing.

3.3. BLOCK DIAGRAM OF TEST SETUP FOR RADIATED EMISSION MEASUREMENTS

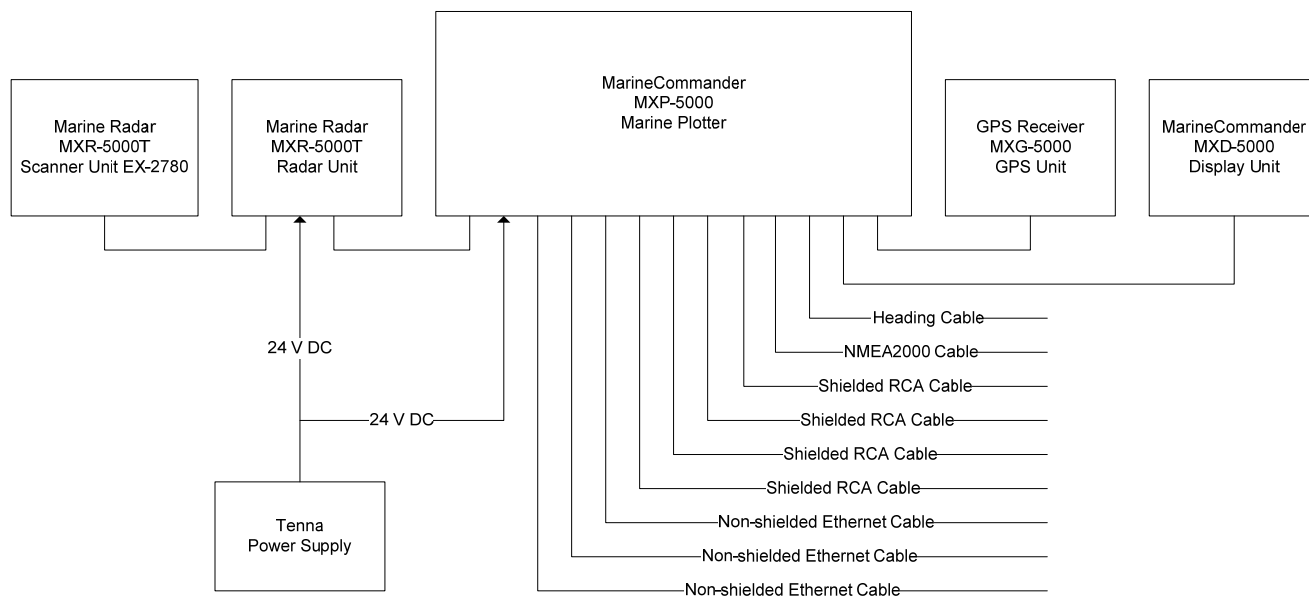

3.4. PHOTOGRAPHS OF TEST SETUP FOR RADIATED EMISSION MEASUREMENTS

Radiated Emissions at 3m Distance



Radiated Emissions at 3m Distance



Radiated Emissions at 3m Distance



EXHIBIT 4. SUMMARY OF TEST RESULTS

4.1. LOCATION OF TESTS

All of the measurements described in this report were performed at Ultratech Group of Labs located in the city of Oakville, Province of Ontario, Canada.

- AC Power Line Conducted Emissions were performed in UltraTech's shielded room, 24'(L) by 16'(W) by 8'(H).
- Radiated Emissions were performed at the Ultratech's 3-10 TDK Semi-Anechoic Chamber situated in the Town of Oakville, province of Ontario. This test site been calibrated in accordance with ANSI C63.4, and found to be in compliance with the requirements of Sec. 2.948 of the FCC Rules. The descriptions and site measurement data of the Oakville 3-10 TDK Semi-Anechoic Chamber has been filed with FCC office (FCC File No.: 91038) and Industry Canada office (Industry Canada File No.: 2049A-3). Expiry Date: 2011-05-01.

4.2. APPLICABILITY & SUMMARY OF EMC EMISSION TEST RESULTS

FCC Part 15, Subpart B	Test Requirements	Margin Below (-) / Above (+) the Limits	Compliance (Yes/No)
15.107(b), Class A	Power Line Conducted Emissions	N/A	N/A
15.109(b), Class A	Radiated Emissions from Unintentional Radiators	-6.8 dB @ 76.8 MHz	Yes

4.3. MODIFICATIONS REQUIRED FOR COMPLIANCE

None.

4.4. DEVIATION OF THE STANDARD TEST PROCEDURES

None.

EXHIBIT 5. MEASUREMENT DATA

5.1. RADIATED EMISSIONS FROM UNINTENTIONAL RADIATORS (DIGITAL DEVICES) [47 CFR 15.109(b)]

5.1.1. Limits

The equipment shall meet the limits of the following table:

Test Frequency Range (MHz)	Class A Limits @ 3 m (dBµV/m)	EMI Detector Used	Measuring Bandwidth (kHz)
30 – 88	49.5	Quasi-Peak	RBW = 120 kHz, VBW ≥ 120 kHz
88 – 216	54.0	Quasi-Peak	RBW = 120 kHz, VBW ≥ 120 kHz
216 – 960	56.9	Quasi-Peak	RBW = 120 kHz, VBW ≥ 120 kHz
Above 960	60.0	Quasi-Peak (≤ 1GHz) Average (> 1GHz)	RBW = 120 kHz, VBW ≥ 120 kHz RBW = 1 MHz, VBW = 10 Hz

5.1.2. Method of Measurements

Refer to Ultratech Test Procedures ULTR-P001-2004 & ANSI C63.4 for method of measurements.

The spectrum shall be investigated from the lowest radio frequency signal generated or used in the device, without going below the lowest frequency for which a radiated emission limit is specified, up to the frequency shown in the following table:

Highest frequency generated or used in the device or on which the device operates or tunes (MHz)	Upper frequency of measurement range (MHz)
Below 1.705	30
1.705 – 108	1000
108 – 500	2000
500 -1000	5000
Above 1000	5 th harmonic of the highest frequency or 40 GHz, whichever is lower

5.1.3. Test Equipment List

Refer to Exhibit 6 for Test Instruments & Measurement Uncertainty.

5.1.4. Test Data

Remarks:

- The measuring receiver shall be tuned over the frequency range 30 MHz to 40 GHz.
- All spurious emissions that are in excess of 20 dB below the specified limit shall be recorded.

Frequency (MHz)	RF Level (dB μ V/m)	Detector Used (Peak/QP)	Antenna Plane (H/V)	Limit (dB μ V/m)	Margin (dB)
38.5	36.1	Peak	V	49.5	-13.4
47.0	38.0	Peak	V	49.5	-11.5
65.3	30.6	Peak	V	49.5	-18.9
76.8	42.7	Peak	V	49.5	-6.8
76.8	31.4	Peak	H	49.5	-18.1
80.6	36.3	Peak	V	49.5	-13.2
80.6	33.3	Peak	H	49.5	-16.2
87.0	39.0	Peak	V	49.5	-10.5
87.0	39.4	Peak	H	49.5	-10.1
100.6	34.9	Peak	V	54.0	-19.1
100.6	36.8	Peak	H	54.0	-17.2
120.5	36.0	Peak	V	54.0	-18.0
120.5	37.3	Peak	H	54.0	-16.7
128.2	45.8	Peak	V	54.0	-8.2
128.2	37.0	Peak	H	54.0	-17.0
130.3	42.2	Peak	V	54.0	-11.8
130.3	40.5	Peak	H	54.0	-13.5
140.5	42.8	Peak	V	54.0	-11.2
153.3	40.8	Peak	V	54.0	-13.2
153.3	38.3	Peak	H	54.0	-15.7
157.1	37.1	Peak	V	54.0	-16.9
160.5	38.7	Peak	V	54.0	-15.3
172.4	35.8	Peak	V	54.0	-18.2
172.4	41.8	Peak	H	54.0	-12.2
191.5	36.3	Peak	V	54.0	-17.7
191.5	38.7	Peak	H	54.0	-15.3
220.6	37.7	Peak	V	56.9	-19.2
220.6	37.0	Peak	H	56.9	-19.9
229.9	39.7	Peak	V	56.9	-17.2
229.9	41.5	Peak	H	56.9	-15.4
248.8	42.7	Peak	H	56.9	-14.2
265.7	38.3	Peak	V	56.9	-18.6
265.7	36.9	Peak	H	56.9	-20.0

ULTRATECH GROUP OF LABS

3000 Bristol Circle, Oakville, Ontario, Canada L6H 6G4
Tel. : 905-829-1570, Fax. : 905-829-8050

File #: ICOM-254F15B

November 22, 2010

All test results contained in this engineering test report are traceable to National Institute of Standards and Technology (NIST)

Frequency (MHz)	RF Level (dBµV/m)	Detector Used (Peak/QP)	Antenna Plane (H/V)	Limit (dBµV/m)	Margin (dB)
267.8	39.3	Peak	V	56.9	-17.6
267.8	47.6	Peak	H	56.9	-9.3
306.2	40.7	Peak	V	56.9	-16.2
337.5	39.5	Peak	V	56.9	-17.4
344.1	40.1	Peak	V	56.9	-16.8
344.1	39.0	Peak	H	56.9	-17.9
363.1	39.8	Peak	V	56.9	-17.1
363.1	37.1	Peak	H	56.9	-19.8
382.6	41.0	Peak	V	56.9	-15.9
382.6	41.8	Peak	H	56.9	-15.1
420.9	37.1	Peak	V	56.9	-19.8
459.1	37.8	Peak	V	56.9	-19.1
459.1	43.7	Peak	H	56.9	-13.2
497.9	38.4	Peak	V	56.9	-18.5
497.9	42.9	Peak	H	56.9	-14.0
574.2	37.6	Peak	V	56.9	-19.3
574.2	43.7	Peak	H	56.9	-13.2
595.5	42.9	Peak	V	56.9	-14.0
595.5	38.2	Peak	H	56.9	-18.7
612.3	40.9	Peak	H	56.9	-16.0
619.1	42.2	Peak	V	56.9	-14.7
619.1	39.1	Peak	H	56.9	-17.8
650.0	42.8	Peak	V	56.9	-14.1
650.0	40.8	Peak	H	56.9	-16.1
650.4	42.5	Peak	V	56.9	-14.4
650.4	40.3	Peak	H	56.9	-16.6
692.4	44.3	Peak	V	56.9	-12.6
692.4	37.5	Peak	H	56.9	-19.4
841.0	40.9	Peak	V	56.9	-16.0
841.0	39.6	Peak	H	56.9	-17.3
878.8	43.3	Peak	V	56.9	-13.6
878.8	41.5	Peak	H	56.9	-15.4
966.8	41.1	Peak	V	60.0	-18.9
966.8	40.6	Peak	H	60.0	-19.4
1010.0	50.4	Peak	V	60.0	-9.6
1010.0	43.9	Peak	H	60.0	-16.1
1128.0	44.9	Peak	V	60.0	-15.1
1128.0	43.4	Peak	H	60.0	-16.6

ULTRATECH GROUP OF LABS

3000 Bristol Circle, Oakville, Ontario, Canada L6H 6G4
 Tel. : 905-829-1570, Fax. : 905-829-8050

File #: ICOM-254F15B
 November 22, 2010

All test results contained in this engineering test report are traceable to National Institute of Standards and Technology (NIST)

Frequency (MHz)	RF Level (dB μ V/m)	Detector Used (Peak/QP)	Antenna Plane (H/V)	Limit (dB μ V/m)	Margin (dB)
1337.0	44.8	Peak	V	60.0	-15.2
1337.0	44.5	Peak	H	60.0	-15.5
3241.0	48.4	Peak	V	60.0	-11.6
3241.0	50.3	Peak	H	60.0	-9.7

EXHIBIT 6. MEASUREMENT UNCERTAINTY

The measurement uncertainties stated were calculated in accordance with the requirements of CISPR 16-4-2 @ IEC:2003 and JCGM 100:2008 (GUM 1995) – Guide to the Expression of Uncertainty in Measurement.

6.1. LINE CONDUCTED EMISSION MEASUREMENT UNCERTAINTY (0.15-30 MHz)

Test Instruments	Manufacturer	Model No.	Serial No.	Frequency Range	Cal Due Date
EMI Receiver System/ Spectrum Analyzer with built-in Amplifier	Hewlett Packard	8546A	3650A00371	9kHz - 6.5GHz	1/25/2011
Attenuator	Pasternack	PE7010-20	---	DC to 2 GHz 20dB attenuation	1/4/2011
L.I.S.N. Used	EMCO	3810/2	2209	9 kHz – 30 MHz	12/18/2010
Coupling Decoupling Network	Fischer Custom Communications Inc.	FCC-801-S9	24	150 kHz - 230 MHz	2/18/2011

	Line Conducted Emission Measurement Uncertainty (150 kHz – 30 MHz):	Measured	Limit
u_c	Combined standard uncertainty: $u_c(y) = \sqrt{\sum_{i=1}^m u_i^2(y)}$	± 1.57	± 1.8
U	Expanded uncertainty U: $U = 2u_c(y)$	± 3.14	± 3.6

6.2. RADIATED EMISSION MEASUREMENT UNCERTAINTY

Test Instruments	Manufacturer	Model No.	Serial No.	Frequency Range	Cal Due Date
EMI Receiver	Rohde & Schwarz	ESU40	100037	20 Hz to 40 GHz	9 Mar 2011
Pre Amplifier	AH System	PAM-0118	225	20 MHz to 18 GHz	8 Mar 2011
Biconilog Antenna	EMCO	3142C	00026873	26 – 3000 MHz	18 Apr 2011
Horn Antenna	EMCO	3115	6570	1GHz – 18 GHz	20 Nov 2010
Semi-Anechoic Chamber	TDK	FCC: 91038 IC: 2049A-3	--	--	1 May 2011
Horn Antenna	ETS Lindgren	3160-09	00118385	18 - 26.5 GHz	17 Jul 2011
Horn Antenna	ETS Lindgren	3160-10	00102686	26.5 - 40 GHz	17 Jul 2011

	Radiated Emission Measurement Uncertainty @ 3m, Horizontal (30-1000 MHz):	Measured	Limit
u_c	Combined standard uncertainty: $u_c(y) = \sqrt{\sum_{i=1}^m u_i^2(y)}$	± 2.15	± 2.6
U	Expanded uncertainty U: $U = 2u_c(y)$	± 4.30	± 5.2

	Radiated Emission Measurement Uncertainty @ 3m, Vertical (30-1000 MHz):	Measured	Limit
u_c	Combined standard uncertainty: $u_c(y) = \sqrt{\sum_{i=1}^m u_i^2(y)}$	± 2.39	± 2.6
U	Expanded uncertainty U: $U = 2u_c(y)$	± 4.78	± 5.2

	Radiated Emission Measurement Uncertainty @ 3 m, Horizontal & Vertical (1 – 18 GHz):	Measured	Limit
u_c	Combined standard uncertainty: $u_c(y) = \sqrt{\sum_{i=1}^m u_i^2(y)}$	± 1.87	Under consideration
U	Expanded uncertainty U: $U = 2u_c(y)$	± 3.75	Under consideration

EXHIBIT 7. LABELLING & FCC AUTHORIZATION REQUIREMENTS

7.1. SECTION 15.19 - LABELLING REQUIREMENTS

(a) In addition to the requirements in part 2 of this chapter, a device subject to certification, or verification shall be labelled as follows:

- (1) Receivers associated with the operation of a licensed radio service, e.g., FM broadcast under part 73 of this chapter, land mobile operation under part 90, etc., shall bear the following statement in a conspicuous location on the device:

This device complies with part 15 of the FCC Rules. Operation is subject to the condition that this device does not cause harmful interference.

- (2) A stand-alone cable input selector switch, shall bear the following statement in a conspicuous location on the device:

This device is verified to comply with part 15 of the FCC Rules for use with cable television service.

- (3) All other devices shall bear the following statement in a conspicuous location on the device:

This device complies with part 15 of the FCC Rules. Operation is subject to the following two conditions: (1) This device may not cause harmful interference, and (2) this device must accept any interference received, including interference that may cause undesired operation.

- (4) Where a device is constructed in two or more sections connected by wires and marketed together, the statement specified under paragraph (a) of this section is required to be affixed only to the main control unit.

- (5) When the device is so small or for such use that it is not practicable to place the statement specified under paragraph (a) of this section on it, the information required by this paragraph shall be placed in a prominent location in the instruction manual or pamphlet supplied to the user or, alternatively, shall be placed on the container in which the device is marketed. However, the FCC identifier or the unique identifier, as appropriate, must be displayed on the device.

7.2. SECTION 15.21 - INFORMATION TO USER

The users manual or instruction manual for an intentional or unintentional radiator shall caution the user that changes or modifications not expressly approved by the party responsible for compliance could void the user's authority to operate the equipment. In cases where the manual is provided only in a form other than paper, such as on a computer disk or over the Internet, the information required by this section may be included in the manual in that alternative form, provided the user can reasonably be expected to have the capability to access information in that form.

7.3. SECTION 15.105 - INFORMATION TO THE USER

- (a) For a Class A digital device or peripheral, the instructions furnished the user shall include the following or similar statement, placed in a prominent location in the text of the manual:

NOTE: This equipment has been tested and found to comply with the limits for a Class A digital device, pursuant to part 15 of the FCC Rules. These limits are designed to provide reasonable protection against harmful interference when the equipment is operated in a commercial environment. This equipment generates, uses, and can radiate radio frequency energy and, if not installed and used in accordance with the instruction manual, may cause harmful interference to radio communications. Operation of this equipment in a residential area is likely to cause harmful interference in which case the user will be required to correct the interference at his own expense.

- (b) For a Class B digital device or peripheral, the instructions furnished the user shall include the following or similar statement, placed in a prominent location in the text of the manual:

NOTE: This equipment has been tested and found to comply with the limits for a Class B digital device, pursuant to part 15 of the FCC Rules. These limits are designed to provide reasonable protection against harmful interference in a residential installation. This equipment generates, uses and can radiate radio frequency energy and, if not installed and used in accordance with the instructions, may cause harmful interference to radio communications. However, there is no guarantee that interference will not occur in a particular installation. If this equipment does cause harmful interference to radio or television reception, which can be determined by turning the equipment off and on, the user is encouraged to try to correct the interference by one or more of the following measures:

- Reorient or relocate the receiving antenna.
- Increase the separation between the equipment and receiver.
- Connect the equipment into an outlet on a circuit different from that to which the receiver is connected.
- Consult the dealer or an experienced radio/TV technician for help.

- (c) The provisions of paragraphs (a) and (b) of this section do not apply to digital devices exempted from the technical standards under the provisions of § 15.103.
- (d) For systems incorporating several digital devices, the statement shown in paragraph (a) or (b) of this section needs to be contained only in the instruction manual for the main control unit.
- (e) In cases where the manual is provided only in a form other than paper, such as on a computer disk or over the Internet, the information required by this section may be included in the manual in that alternative form, provided the user can reasonably be expected to have the capability to access information in that form.

7.4. SECTION 2.902 – VERIFICATION

- (a) Verification is a procedure where the manufacturer makes measurements or takes the necessary steps to insure that the equipment complies with the appropriate technical standards. Submittal of a sample unit or representative data to the Commission demonstrating compliance is not required unless specifically requested by the Commission pursuant to § 2.957, of this part.
- (b) Verification attaches to all items subsequently marketed by the manufacturer or importer which are identical as defined in § 2.908 to the sample tested and found acceptable by the manufacturer.

7.5. SECTION 2.909 - RESPONSIBLE PARTY

The following parties are responsible for the compliance of radio frequency equipment with the applicable standards:

- (b) In the case of equipment subject to authorization under the verification procedure, the manufacturer or, in the case of imported equipment, the importer. If subsequent to manufacture and importation, the radio frequency equipment is modified by any party not working under the authority of the responsible party, the party performing the modification becomes the new responsible party.

7.6. SECTION 2.945 – SAMPLING TESTS OF EQUIPMENT COMPLIANCE

The Commission will, from time to time, request the responsible party to submit equipment subject to this chapter to determine the extent to which subsequent production of such equipment continues to comply with the data filed by the applicant (or on file with the responsible party for equipment subject to notification or a Declaration of Conformity). Shipping costs to the Commission's laboratory and return shall be borne by the responsible party.

7.7. SECTION 2.946 – PENALTY FOR FAILURE TO PROVIDE TEST SAMPLES AND DATA

- (a) Any responsible party, as defined in § 2.909, or any party who markets equipment subject to the provisions of this chapter, shall provide test sample(s) or data upon request by the Commission. Failure to comply with such a request within 14 days may be cause for forfeiture, pursuant to § 1.80 of this chapter, or other administrative sanctions such as suspending action on any applications for equipment authorization submitted by such party while the matter is being resolved.
- (b) The Commission may consider extensions of time upon submission of a showing of good cause.

7.8. SECTION 2.952 - LIMITATION ON VERIFICATION

- (a) Verification signifies that the manufacturer or importer has determined that the equipment has been shown to be capable of compliance with the applicable technical standards if no unauthorized change is made in the equipment and if the equipment is properly maintained and operated. Compliance with these standards shall not be construed to be a finding by the manufacturer or importer with respect to matters not encompassed by the Commission's rules.
- (b) Verification of the equipment by the manufacturer or importer is effective until a termination date is otherwise established by the Commission.
- (c) No person shall, in any advertising matter, brochure, etc., use or make reference to a verification in a deceptive or misleading manner or convey the impression that such verification reflects more than a determination by the manufacturer or importer that the device or product has been shown to be capable of compliance with the applicable technical standards of the Commission's Rules.

7.9. SECTION 2.953 - RESPONSIBILITY OF COMPLIANCE

- (a) In verifying compliance, the responsible party, as defined in § 2.909 warrants that each unit of equipment marketed under the verification procedure will be identical to the unit tested and found acceptable with the standards and that the records maintained by the responsible party continue to reflect the equipment being produced under such verification within the variation that can be expected due to quantity production and testing on a statistical basis.
- (b) The importer of equipment subject to verification may upon receiving a written statement from the manufacturer that the equipment complies with the appropriate technical standards rely on the manufacturer or independent testing agency to verify compliance. The test records required by § 2.955 however should be in the English language and made available to the Commission upon a reasonable request, in accordance with § 2.956.
- (c) In the case of transfer of control of equipment, as in the case of sale or merger of the grantee, the new manufacturer or importer shall bear the responsibility of continued compliance of the equipment.
- (d) Verified equipment shall be reverified if any modification or change adversely affects the emanation characteristics of the modified equipment. The party designated in § 2.909 bears responsibility for continued compliance of subsequently produced equipment.

7.10. SECTION 2.954 - IDENTIFICATION

Devices subject only to verification shall be uniquely identified by the person responsible for marketing or importing the equipment within the United States. However, the identification shall not be of a format which could be confused with the FCC Identifier required on certified, notified or type accepted equipment. The importer or manufacturer shall maintain adequate identification records to facilitate positive identification for each verified device.

7.11. SECTION 2.955 - RETENTION OF RECORDS

- (a) For each equipment subject to verification, the manufacturer (or importer) shall maintain the records listed below:
 - (1) A record of the original design drawings and specifications and all changes that have been made that may affect compliance with the requirements of Section 2.953.
 - (2) A record of the procedures used for production inspection and testing (if tests were performed) to insure the conformance required by Section 2.953. (Statistical production line emission testing is not required).
- (b) The records listed in paragraphs (a) of this section shall be retained for two years after the manufacture of said equipment item has been permanently discontinued, or until the conclusion of an investigation or a proceeding if the manufacturer or importer is officially notified that an investigation or any other administrative proceeding involving his equipment has been instituted.

7.12. SECTION 2.956 - FCC INSPECTION & SUBMISSION OF EQUIPMENT FOR TESTING

- (a) Each responsible party shall upon receipt of reasonable request:
- (1) Submit to the Commission the records required by § 2.955.
 - (2) Submit one or more sample units for measurements at the Commission's Laboratory.
 - (i) Shipping costs to the Commission's Laboratory and return shall be borne by the responsible party.
 - (ii) In the event the responsible party believes that shipment of the sample to the Commission's Laboratory is impractical because of the size or weight of the equipment, or the power requirement, or for any other reason, the responsible party may submit a written explanation why such shipment is impractical and should not be required.
- (b) Requests for the submission of the records in § 2.955 or for the submission of sample units are covered under the provisions of § 2.946.