

Abridged English Manual

For more information about handset operations and functions, please dial 157 from a Vodafone handset for Customer Service.

Contents

Safety Precautions	16-4
■ General Notes for Handling	16-14
■ FCC notice	16-19
■ SAR	16-21
USIM Card	16-22
■ Using USIM Card	16-22
■ Inserting/Removing USIM Card	16-24
Handset Parts & Functions	16-25
■ Handset	16-25
■ Charging the Battery	16-27
■ Display Indicators	16-28
■ Conventions Used in this Manual	16-30
■ Codes	16-31
■ PIN	16-32
Basic Handset Operations	16-33
■ Handset Power On/Off	16-33
■ Retrieving Network Information	16-33
■ Changing Display Language to English	16-33
■ Displaying My Phone Number	16-33
■ Setting Date & Time	16-34
■ Switching Between 3G/GSM Area Modes	16-34
■ Making a Call	16-35
■ Making an International Call	16-35
■ Receiving a Call	16-35
■ Calling from Redial List/Received Calls List	16-35
■ Placing a Caller on Hold	16-36
■ Message Recorders and Voice Mail	16-36
■ Call Forwarding	16-37
■ Total Call Time/Charges	16-37
■ Manner Mode	16-37
Entering Text	16-39
■ Input Mode	16-39
■ Key Assignments	16-40
Phone Book	16-41
■ Phone Book Entry Items	16-41
■ Saving Information to Phone Book	16-42
■ Editing Phone Book Entries	16-42
■ Saving a Number from Received Calls	16-43
Dialing a Number from Phone Book	16-44
■ Searching by Memory Number	16-44
■ Searching by Reading	16-44
TV Call	16-45

■ Display Indicators during a TV Call	16-45
■ Making a TV Call	16-45
■ Receiving a TV Call	16-45
Using Camera	16-46
■ Before Using Camera	16-46
■ Taking Pictures	16-47
■ Shooting Videos	16-48
Audio & Video	16-49
Memory Cards	16-50
■ Before Using a Memory Card	16-51
■ Inserting/Removing a Memory Card	16-52
Data Folder	16-53
■ Data Folder Structure	16-54
IrDA Infrared Data Communication	16-55
Optional Services	16-56
F-Functions	16-57
Main Specifications	16-59
Customer Service	16-60

Safety Precautions

- To ensure safe use of the handset, please read these Safety Precautions carefully before use. After reading, please keep the Safety Precautions for future reference.
- The following precautions are provided for your benefit to protect you and others and to avoid damage to property. Please observe these Safety Precautions.

This manual uses various icons to facilitate your understanding of the contents, ensure correct use to prevent injury to yourself or others and prevent damage to assets. The icons used and their meanings are described below. Read the main text after you thoroughly understand the contents.

 **Danger** Improper handling poses a high risk of death or serious injury.

 **Warning** Improper handling poses the risk of death or serious injury.

 **Caution** Improper handling poses the risk of injury or damage to the product or property.

Examples



The action is prohibited.



The action is compulsory.



The power cable must be unplugged.

In the event of failure

If the handset emits smoke or an abnormal smell or noise, turn the power off. If an irregularity occurs during charging, unplug the power cable from the outlet and contact your nearest customer center.

J-Phone shall not be liable for any damages incurred by you or a third party as a result of improper use of this product, failure during use, or any other nonconformity, unless the liabilities are specified by Japanese laws or regulations.

Danger

■ Handset

● Do not use when thunder sounds.

If you hear thunder while using your phone on a golf course, etc., cease using the phone immediately. There is a risk of electric shock or death from being struck by lightning.



Prohibited

● Do not use where inflammable gas is generated.

Do not use your phone if there is a risk of fire or explosion. Turn off the phone and refrain from charging in places where propane gas, gasoline or other inflammable gases are present.



Prohibited

16

■ Battery

● Use only the specified charger. Do not use the charger for batteries other than V801SA.

Failure to observe the following precautions may lead to electric shock, fire, bursting, overheating, igniting or leakage of the battery, overheating, igniting or failure of the charger.

- Use only the specified charger to recharge the battery.
- Do not use the charger for batteries other than V801SA.



Compulsory

● Do not short-circuit the terminals.

Short-circuiting of the battery terminals with a car key or metal accessory, etc., may result in bursting, overheating, igniting or leakage of the battery. Always place in the battery case provided when carrying or storing the battery.



Prohibited

● Do not disassemble or modify.

Disassembly or modification of the battery may result in electric shock, fire, bursting, overheating, igniting or leakage of the battery, overheating, igniting or failure of the charger.



Disassembly prohibited

● Do not throw into a fire.

Do not place the battery near fire or throw into a fire as this may result in bursting, overheating, igniting or leakage of the battery.



Prohibited

Danger

● **Do not subject to strong impact.**

Subjecting the battery to shock by dropping, bumping or hitting with a hammer may result in bursting, overheating, igniting or leakage of the battery.



Prohibited

● **Do not touch the charger terminals or power plug with wet hands.**

Do not touch the battery terminals, charger terminals or power plug with wet hands as this may result in electric shock or failure.



Prohibited

● **Do not charge the battery where inflammable gas is generated.**

Never charge the battery in a place where propane gas, gasoline or other inflammable gases are present.



Prohibited

Warning

■ **Memory Card**

● **Do not keep the Memory Card within children's reach.**

Children may mistakenly swallow it. If children swallow it, consult a doctor immediately.



Prohibited

Warning

■ Handset Use & Medical Equipment

These safety precautions are based on the guidelines produced at the Electromagnetic Compatibility Conference, Japan (April, 1997) and refer to the report produced at the Association of Radio Industries and Business (March, 2001).

16

-
- **If a mobile phone is used in the vicinity of an implanted cardiac pacemaker and implanted defibrillator or other electronic medical equipment, the equipment may be affected by the radio emissions. Please observe the following guidelines:**



Compulsory

- 1 Do not use the handset within 22cm of a cardiac pacemaker or implanted cardiac defibrillator.
- 2 In crowded areas such as on a train during rush hour, turn off your phone. Someone using an implanted cardiac pacemaker and implanted cardiac defibrillator may be near you. If your phone has an automatic power-on or alarm setting, cancel the setting.
- 3 Implanted cardiac pacemakers and implanted cardiac defibrillators can be affected by radio emissions from mobile phones.
- 4 Comply with the following in hospitals and health care facilities.
 - Do not take the phone into operating theatres, intensive care units (ICU), or coronary care units (CCU).
 - Turn off your phone in wards. If your phone has an automatic power-on or alarm setting, cancel the setting.
 - Turn off your phone in the lobby or anywhere where there are electronic medical devices near you. If your phone has an automatic power-on or alarm setting, cancel the setting.
 - Comply with the regulations of the hospital or health care facility regarding mobile phone use.
- 5 Patients using electronic medical equipment other than implanted cardiac pacemaker and implanted cardiac defibrillator should consult with the manufacturer to confirm whether or not its operation is effected by radio waves.

Warning

■ Handset

● Do not use inside an aircraft.

Turn off the phone in aircraft. The electromagnetic waves generated by the phone may affect the electronic equipment of the aircraft, impeding safety.



Prohibited

● Do not use while driving.

Do not use the phone while driving a car as this may cause an accident. Before using the phone, stop the car in a safe place.



Prohibited

● Do not disassemble or modify.

Do not disassemble or modify the phone. Electric shock, fire or failure may result. Modification is a violation of the radio wave law.



Disassembly prohibited

● Do not subject to strong impact.

If the phone is subjected to shock caused by dropping, bumping, etc., the electronic components may become loose or damaged, resulting in electric shock, fire or failure.



Prohibited

● Turn off if an abnormal smell or smoke is emitted.

If there is an abnormal smell or smoke is emitted, turn off the phone and remove the battery.



Compulsory

● Keep out of the reach of children.

To prevent accidents such as electric shock or fire, keep out of the reach of children.



Compulsory

■ Battery

● If a leak is present, keep away from fire.

In the event of leakage or an abnormal smell of the battery, keep away from fire. The leaking fluid may ignite and then cause a fire.



Compulsory

● If battery fluid gets in your eyes, rinse immediately with clean water.

If battery fluid gets in your eyes or on your skin as a result of battery damage, rinse with clean water and consult a doctor immediately. Battery fluid may cause blindness or inflammation of the skin.



Compulsory

Warning

- **Do not place in a microwave oven or dryer.**

Do not put into a microwave oven or dryer as this may result in bursting, overheating, igniting or leakage of the battery.



Prohibited

- **Do not get the battery wet or use when wet.**

A wet battery may result in electric shock, fire, bursting, overheating, igniting or leakage of the battery, and failure of the charger.



Prohibited

- **Do not use if there is a smell or overheating.**

Abnormal smell or overheating may result in electric shock, fire, bursting, igniting or leakage of the battery and failure of the charger.



Prohibited

- **Do not use the battery when it has damage.**



Prohibited

■ **Charger**

- **Do not charge any battery other than the one specified.**

Charging other batteries may result in fire, bursting, overheating, igniting or leakage of the battery, and failure of the charger.



Prohibited

- **Do not short-circuit the charger terminals.**

Do not short-circuit the charger terminals as this may result in electric shock, fire, bursting, overheating, igniting or failure of the charger.



Prohibited

- **Do not disassemble or modify.**

Disassembly or modification may result in electric shock, fire, bursting, overheating, igniting or failure of the charger.



Disassembly prohibited

- **Do not use the charger where inflammable gas is generated.**

Never charge the battery in a place where propane gas, gasoline or other inflammable gases are present.



Prohibited

Warning

- **Do not use other than a home use AC100-240V outlet.**



Prohibited

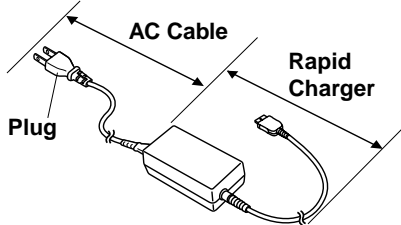

- Use the Rapid Charger with a home use AC100-240V outlet only. Using an outlet other than specified may cause fire or damage, overheating, ignition or failure of the charger.
- The AC cable that came with the product is for use in Japan only. Do not use it overseas. If you intend to use the charger overseas, buy the appropriate AC cable for the country you are visiting.
- We shall not be liable for any damage caused by problems with charging overseas.

- **Do not expose the charger to water.**



Prohibited

Water on the charger may lead to electric shock, fire, bursting, overheating, igniting or leakage of the battery, and failure of the charger.

- **Handle the power cable correctly.**



Compulsory

Failure to comply with the following may result in fire or electric shock.

- When unplugging the power cable, be sure to hold the plug.
- Do not modify or damage the power cable. Do not use with the power cable trapped in a door, etc.
- Do not place heavy articles on the power cable, or pull or twist it.

- **Do not use if there is an abnormal smell or overheating.**



Unplug power cable

If an abnormal noise, smell or smoke is emitted during charging, unplug the power cable from the outlet immediately and remove the battery from the charger. Continued use may result in electric shock, fire, bursting, overheating, igniting or leakage of the battery, and failure of the charger.

- **Do not touch the charger terminals or power plug with wet hands.**



Prohibited

Touching the terminals of the battery or charger or the power plug with wet hands may result in electric shock or failure.

Caution

■ Handset

● **Check the receiver.**

The receiver contains a magnet and unexpected injury may result due to metal objects such as tacks and pins attaching themselves to the receiver. Before using, always check that there is nothing attached to the receiver.



Compulsory

● **Do not leave in wet and humid places or in extreme temperatures.**

Do not leave the phone in the following places as there is a risk of fire, bursting, explosion, igniting or leakage of the battery, and failure of the charger.

- Where there is vibration, dust or high humidity.
- Where it is liable to get water, rain, seawater, juice, etc. on it.
- Where it is exposed to direct sunlight, or near heating equipment.



Prohibited

● **Keep away from magnetic cards.**

The rear speaker and receiver contain a magnet and should be kept away from floppy disks or cash cards as the contents of the memory may be erased.



Prohibited

● **Do not use near electronic equipment.**

Use of the phone near electronic equipment with precision control or lowpowered signals, such as electronic medical equipment or automatically controlled equipment, may affect the electronic equipment. If you use the phone near a regular phone, TV, or radio, the equipment may be affected. In rare cases, the phone may affect the electronic equipment in a car, depending on the type of car.



Prohibited

● **Handling the phone as follows may result in failure or damage.**

- Avoid sitting with the phone in the back pocket of your trousers.
- If you put the phone in your bag, make sure that you do not put heavy objects on top of it.



Prohibited

Caution

- **If skin irritations occur, stop using handset immediately and consult a doctor.**



Compulsory

Conditions such as skin irritations, a rash or eczema may develop in some rare cases.

Part	Material	Surface Finish
Outer Case (front side Display)	Magnesium Alloy	Baked Acrylic Paint
Outer Case (others)	PC/ABS Resin	Acrylic UV Cured Coating
Display	Acrylic Resin	None
Battery Case	Polycarbonate Resin	Acrylic UV Cured Coating
Keys (except plated keys)	Polycarbonate Resin	Acrylic UV Cured Coating
Keys (plated keys)	ABS Resin	Chrome Plated
Antenna	ABS Resin	None
Headset Jack and External Connector Covers	Elastomer Resin	None

Caution

■ Battery

- **Do not leave in wet and humid places or in extreme temperatures.**



Prohibited

Such action may result in fire, bursting, overheating, igniting or leakage of the battery, and deformation or damage of the soft case.

- **Keep out of the reach of children.**



Compulsory

To prevent accidents such as electric shock or fire, keep the battery out of the reach of children.

■ Charger

- **Do not leave in wet and humid places or in extreme temperatures.**



Prohibited

Such action may result in fire, bursting, overheating, igniting or leakage of the battery, and failure of the charger.

- **Keep out of the reach of children.**



Compulsory

To prevent accidents such as electric shock or fire, keep the charger out of the reach of children.

- **Do not subject to strong impact.**



Prohibited

Subjecting the charger to shock by dropping, bumping or hitting it with a hammer may result in damage, overheating, igniting or failure of the charger.

General Notes for Handling

■ Handset

- As V801SA uses radio waves, you cannot make or receive calls where radio waves do not reach such as: indoors, underground or inside a tunnel. Also, your call may suddenly be cut off if during a call.
- When using V801SA in public places, take care not to disturb people around you.
- V801SA is a radio station specified by Japanese radio law. You may be requested to submit the phone for inspection based on this law.
- If you use the phone near a regular phone, TV or radio, the equipment may be affected.
- J-Phone takes no responsibility for loss or corruption of data (such as memory dialing, image or sound data) that has been registered in your V801SA due to accidents or equipment malfunctions. It is recommended that you always make a separate record of important data such as memory dial data.
- 3G (Japan) mode can be used only in Japan.

■ Using Handset in Automobiles

- It is dangerous to use V801SA while driving a car and should be avoided.
- Do not stop your car in a prohibited place to use V801SA.
- If you use V801SA in a car, in rare cases it may affect the electronic equipment in the car, depending on the type of car.

■ Aboard Aircraft

- Never use your phone or switch it on in an aircraft.

■ Maintenance

- Do not use V801SA in extremely high or low temperatures or where exposed to direct sunlight.
- Do not subject V801SA to impact by dropping it, or place a heavy object on top of it as this may lead to failure.
- Use a soft dry cloth to clean your phone. Do not use alcohol, thinner or benzine as this may result in discoloration or cause the lettering to fade.
- V801SA is not waterproof. Take care not to get it wet if using it by a river or lake, etc. Using the phone in the rain may lead to failure.
To prevent damage from salt (corrosion of the internal parts), do not expose to sea spray or salt air when using the phone by the sea.

- Take care not to expose the phone to sweat. Sweat running along the antenna can corrode internal parts.
- V801SA is a radio communication device made from precision parts. Never disassemble or modify the phone.
- If the V801SA's battery pack is removed or if V801SA is left with a low battery level for long periods, the data that you have registered in V801SA may become lost or corrupted. J-Phone takes no responsibility for loss or corruption of data that may occur in such situations.

■ Copyrights

- Music, images, computer programs, databases, other copyrighted materials and their respective copyright holders are protected by copyright laws. Duplication of such copyrighted material is permissible only with the purpose of use by the individual or use within the household. If the above purposes are exceeded and copies (including conversion of data types), modifications, transfer of copies or distribution on networks are made without the copyright holder's authorization, this constitutes "Literary Piracy" and "Infringement of Copyright Holder Rights" and a claim of criminal punishment for reparations may be filed. If copies are made using this product, please observe the copyright laws with doing so. Additionally, this product is equipped with a camera function and using the camera function to record materials is also subject to the above, and appropriate use should be observed.

■ General care

The handset contains delicate electronic circuitry, magnets and battery systems. You should treat it with care and give particular attention to the following points:

- Do not allow the handset or its accessories to come into contact with liquids or moisture at anytime.
- Do not paint the handset.
- Do not drop or subject the handset to rough treatment.
- Do not place the handset alongside computer disks, credit cards, travel cards and other magnetic media. The information contained on disks or cards may be affected by the handset.
- Do not leave the handset or the battery in places where the temperature could exceed 60°C, e.g. on a car dashboard or a window sill, behind glass in direct sunlight, etc.
- Do not remove the handset's battery while the handset is switched on.
- Take care not to allow metal objects, such as coins or key rings to contact or short-circuit the battery terminals.

- Do not dispose of battery packs in a fire. The handset's Li-ION batteries may be safely disposed at a Li-ION recycling point.
- Do not put the handset's battery in your mouth, as battery electrolytes may be toxic if swallowed.
- Do not attempt to dismantle the handset or any of its accessories.
- This equipment is fitted with an internal battery that can only be replaced by a qualified service engineer. There is a risk of explosion if the battery is replaced with an incorrect type battery. Dispose of the used battery in accordance with the manufacturer's instructions.
- When charging the battery, use dedicated chargers. Using any battery pack, or mains charger not specified by the manufacturer for use with this handset creates a potential safety hazard.
- Do not put battery into a microwave oven, dryer or high-pressure container.
- Do not contact battery directly to an electric outlet or cigarette lighter charger.
- Do not pierce battery with a sharp object such as a needle.
- Do not use a battery with serious scars or deformation.
- When the battery is thrown away, be sure it is non-conducting by applying vinyl tape to the (+) and (-) terminals.
- Do not immerse, throw or wet battery in water/seawater.
- Do not place battery in a device with the (+) and (-) in the wrong way around.
- Do not disassemble or modify the battery.
- Do not solder a battery directly.
- Do not use battery with dry cells and other primary batteries or batteries of a different package, type or brand.
- Stop using the battery if abnormal heat, odor, discoloration, deformation or abnormal condition is detected during use, charge or storage.
- Keep away from fire immediately when battery leakage or foul odors are detected.
- If battery fluid leaks onto your skin or clothes, wash well with fresh water immediately.
- If fluid leaking from the battery gets into your eyes, do not rub your eyes. Wash them well with clean water and consult a doctor immediately.
- Remove the battery whose life cycle has expired from equipment immediately.

- While the battery is charged, used and stored, keep it away from objects or materials with static electric chargers.
- The earpiece may become warm during normal use. Also, the handset itself may become warm while the battery is being charged.
- Use a damp or anti-static cloth to clean the handset. Do not use a dry cloth or electrostatically charged cloth. Do not use chemical or abrasive cleaners as these could damage the case.
- Remember to recycle: the cardboard packing supplied with this handset is ideal for recycling.
- Remember to make backup copies of all important data on your handset.

■ Aircraft safety

- Switch off the handset when inside or near aircraft.
- The use of the handsets in aircraft is illegal, as it may be dangerous to the operation of the aircraft and it may disrupt the aircraft communication system.
- Failure to observe this instruction may lead to suspension or denial of the offender's handset service, or legal action, or both.
- Do not use the handset on the ground without the permission of the ground staff.

■ General safety

- Observe "Turn off 2-Way radio" signs, such as those near petrol stations, chemicals or explosives and turn off handset/device.
- Do not allow children to play with the handset, charger or batteries.
- Do not use the handset where blasting is in progress.
- The operation of some medical electronic devices, such as hearing aids and pacemakers, may be affected if the handset is used next to them.

■ Road safety

- You MUST exercise proper control of your vehicle at all times. Give your full attention to driving.
- Observe all of the recommendations contained in your local traffic safety documentation.
- Pull off the road and park before making or answering a call, if driving conditions so require.
- You MUST NOT stop on the hard shoulder of a motorway to answer or make a call, except in an emergency.
- Switch off the handset at a refueling point, such as a petrol station, even if you are not refueling your own car.
- Do not store or carry flammable or explosive materials in the same compartment as a radio transmitter.

- Electronic vehicle systems, such as anti-lock brakes, speed control and fuel injection systems are not normally affected by radio transmissions. The manufacturer of such equipment can advise if it is adequately shielded from radio transmissions. If you suspect vehicle problems caused by radio transmissions, consult your dealer and do not switch on the handset until it has been checked by qualified approved installers.
- Check if local laws and/or regulations restrict the use of handsets while driving.

■ Vehicles equipped with an air bag

An air bag inflates with great force. Do not place objects, including either installed or portable wireless equipment, in the area over the air bag or in the air bag deployment area. If in-vehicle wireless equipment is improperly installed and the air bag inflates, serious injury could result.

■ Third party equipment

The use of third party equipment, cables or accessories, not made or authorized by SANYO, may invalidate the warranty of the handset and also adversely affect the handset's operation.

■ Service

The handset, batteries and charger contain no user-serviceable parts. We recommend that the SANYO handset be serviced or repaired by an SANYO authorized service centre.

■ Efficient use

The handset has an internal antenna. For optimum performance with minimum power consumption, please do not cover the internal antenna area with your hand.

■ Radio frequency energy

The handset is a low-power radio transmitter and receiver. When it is turned on, it intermittently receives and transmits radio frequency (RF) energy (radio waves). The system that handles the call controls the power level at which the handset transmits.

■ Declaration of conformity

We declare under our sole responsibility that the product(s) detailed in this manual, and in combination with our accessories, conform with the essential requirements of European Union Directive 1999/5/EC Radio and Telecommunications Terminal Equipment Directive requirements 3.1(a),3.1(b),3.2.

FCC notice

The handset may cause TV or radio interference if used in close proximity to receiving equipment. The FCC can require you to stop using the handset if such interference cannot be eliminated.

If you need assistance, contact your local dealer.

And last, but certainly not least, vehicles using liquefied petroleum gas (such as propane or butane) must comply with the National Fire Protection Standard (NFPA-58). For a copy of this standard, contact the National Fire Protection Association,

One Batterymarch Park, Quincy, MA02269, Attn: Publication Sales Division.

This device complies with part 15 of the FCC rules. Operation is subject to the following two conditions: (1) This device may not cause harmful interference, and (2) this device must accept any interference received, including interference that may cause undesired operation.

Note: This equipment has been tested and found to comply with the limits for a Class B digital device, pursuant to part 15 of the FCC rules. These limits are designed to provide reasonable protection against harmful interference in a residential installation. This equipment generates, uses, and can radiate radio frequency energy and, if not installed and used in accordance with the instructions, may cause harmful interference to radio communications. However, there is no guarantee that interference will not occur in a particular installation. If this equipment does cause harmful interference to radio or television reception, which can be determined by turning the equipment off and on, the user is encouraged to try to correct the interference by one or more of the following measures:

- Reorient or relocate the receiving antenna.
- Increase the separation between the equipment and receiver.
- Connect the equipment into an outlet on circuit different from that to which the receiver is connected.
- Consult the dealer or an experienced radio / TV technician for help and for additional suggestions.

The user may find the following booklet prepared by the Federal Communications Commission helpful: "How to Identify and Resolve Radio-TV interference Problems." This booklet is available from the U.S. Government Printing Office, Washington, D.C. 20402, Stock No. 004-000-00345-4.

■ Warning

The user is cautioned that changes or modifications not expressly approved by the manufacturer could void the user's authority to operate the equipment.

FCC RF EXPOSURE INFORMATION

Warning! Read this information before using the handset.

16

In August 1996 the Federal Communications Commission (FCC) of the United States with its action in Report and Order FCC 96-326 adopted an updated safety standard for human exposure to radio frequency electromagnetic energy emitted by FCC regulated transmitters. Those guidelines are consistent with the safety standard previously set by both U.S. and international standards bodies. The design of the handset complies with the FCC guidelines and these international standards.

■ CAUTION

Use only the supplied or an approved antenna. Unauthorized antennas, modifications or attachments could impair call quality, damage the handset or result in violation of FCC regulations.

Do not use the handset with a damaged antenna. If a damaged antenna comes into contact with the skin, a minor burn may result. Please contact your local dealer for replacement antenna.

■ Body-worn Operation

This device was tested for typical body-worn operations with the back of the handset kept 0.59 inches (1.5cm) from the body. To comply with FCC RF exposure requirements, a minimum separation distance of 0.59 inches (1.5cm) must be maintained between the user's body and the back of the handset, including the antenna, whether extended or retracted. All belt-clips, holsters and similar accessories used by this device must not contain any metallic components. Body-worn accessories that do not meet these requirements may not comply with FCC RF exposure limits and should be avoided.

■ Turn off your phone before flying

You should turn off the handset boarding any aircraft. To prevent possible interference with aircraft systems, U.S. Federal Aviation Administration (FAA) regulations require you to have permission from a crew member to use the handset while the plane is on the ground. To prevent any risk of interference, FCC regulations prohibit using the handset while the plane is in the air.

SAR

The handset has been designed, and manufactured not to exceed the limits for exposure to electromagnetic fields recommended by The Council of the European Union. These limits are part of comprehensive guidelines developed by independent scientific organizations through periodic and thorough evaluation of scientific studies. The guidelines include a substantial safety margin designed to assure the safety of the handset user and others and to take into account variations in age and health, individual sensitivities and environmental conditions. European expose standards for mobile phone provide for the amount of radio frequency electromagnetic energy absorbed by the body when using a mobile phone to be measured by reference to the Specific Absorption Rate (SAR). The SAR limit recommended by The Council of the European Union for mobile phones used by the public is 2.0 watts/kilogram (W/kg) averaged over ten grams of body tissue. The handset SAR value is 0.49 watts per kilogram. This has been tested to ensure that this limit is not exceeded even when the handset is operating at its highest certified power. In use, however, the handset may operate at less than full power because it is designed to use only sufficient power to communicate with the network.



USIM Card

Vodafone Global Standard USIM Card is an IC card that contains customer information such as the phone number. The USIM Card must be installed before using a USIM Card compatible mobile phone. The USIM Card cannot be used with a network other than specified by J-Phone.

16

USIM stands for Universal Subscriber Identity Module.

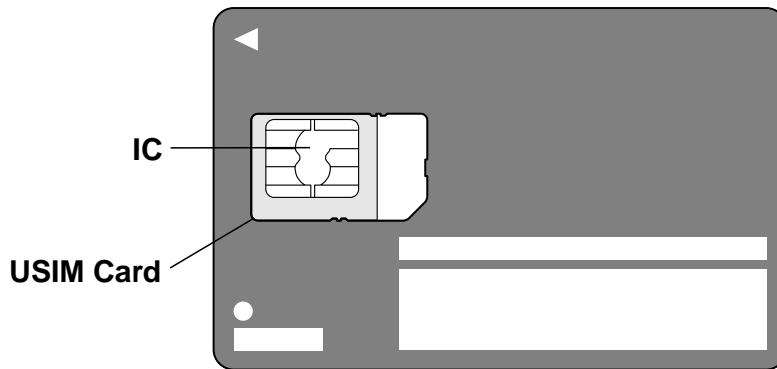

Using USIM Card

Install USIM Card before using the V801SA handset. The following functions are unavailable if USIM Card is not installed or the data on USIM Card cannot be read.

- Displaying My Phone Number
- Saving, searching or copying Phone Book entries on USIM Card
- Launching Java™ applications
- Displaying copyright protected (prohibited from transfer) files in Data Folder
- Starting Audio & Video
- Displaying Total Call Time and Total Call Charge
- Incoming/outgoing calls and mail (Emergency calls can be made without USIM Card)
- Activating Camera

Safety Precautions

- Inserting or removing USIM Card with excessive force may cause equipment failure. Carefully handle the card to avoid injury.
- J-Phone shall not be liable for any malfunction resulting from USIM Card being inserted improperly.
- J-Phone shall not be liable for any malfunction, after USIM Card has been inserted into a third party IC card reader.
- Use USIM Card only in the temperature range of -25°C to 70°C.
- Use USIM Card with equipment specified by J-Phone. Using unspecified equipment may cause data loss or equipment failure.
- Do not drop or apply strong impact to USIM Card. Doing so may cause it to malfunction.
- Do not bend or place heavy objects on USIM Card. Doing so may cause it to malfunction.
- Do not let USIM Card get wet. Do not place it in humid place. Doing so may cause it to malfunction.
- Touching the IC chip of USIM Card may cause data loss or equipment failure. Avoid touching the IC chip of USIM Card.
- Do not use USIM Card in high temperature areas such as near fire or other source of heat. Doing so may cause it to malfunction.
- Do not store USIM Card in high temperature and high humidity. Do not expose it to direct sunlight. Doing so may cause it to malfunction if left in such conditions.
- Keep USIM Card away from infants. They may swallow it or they may get hurt.

Other Cautions

- USIM Card is the property of J-Phone.
- USIM Card will be re-issued for a fee if the card is lost or damaged.
- Return USIM Card to J-Phone when you cancel your subscription.
- Returned USIM Cards are recycled for environmental conservation.
- The specifications and performance of USIM Card are subject to change without advance notice.
- Keep a backup copy of the data stored in USIM Card. J-Phone shall not be liable for any loss of data.

Inserting/Removing USIM Card

Inserting USIM Card

- 1 Remove the battery
- 2 Carefully slide in USIM Card (as pictured below) until it locks into place.

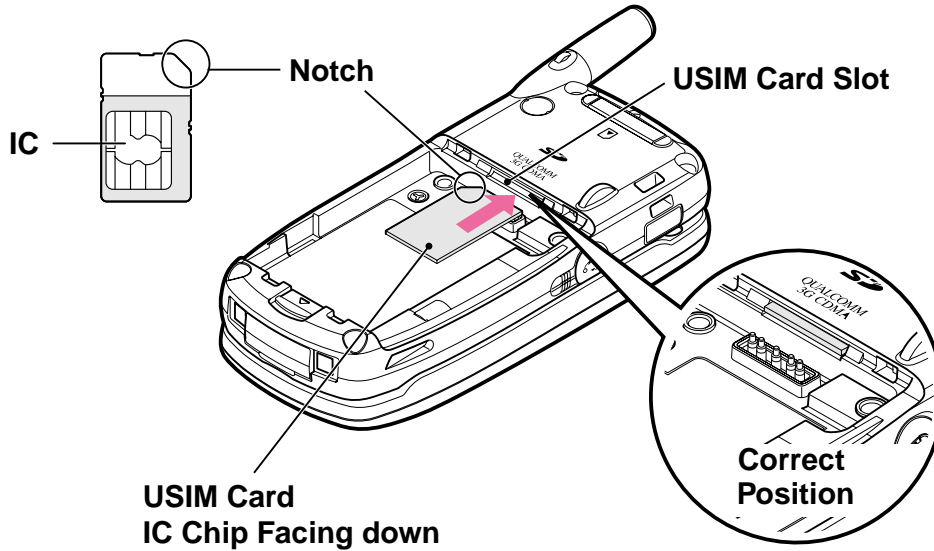

Removing USIM Card

- 1 Remove the battery
- 2 Gently push USIM Card in the direction of the arrow, until it clicks. USIM Card will eject.
- 3 Pull out USIM Card

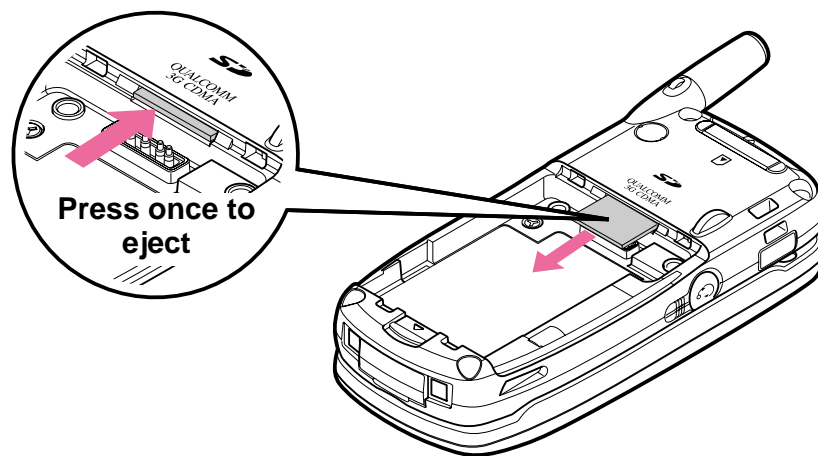

Handset Parts & Functions



Handset

CCD Camera (Back Lens)

Captures still and moving images.

Flash/Spot Light

Use as a flash/spot light when capturing images.

LED Indicator

Lights while capturing moving images.

Antenna

Memory Card Slot

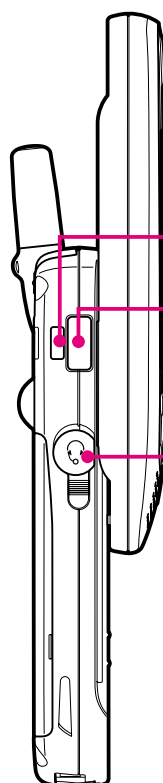
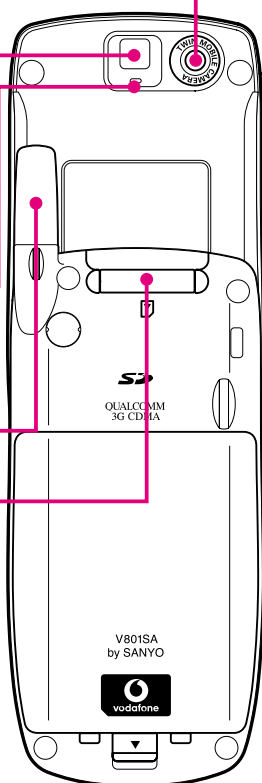

Strap Eyelet

Infrared Port

Sends/receives infrared signals.

Optical Digital Line Input/Headset Jack

Connect optical conversion adaptor, included with handset. Also connect headset (sold separately). Cap it when not in use.

Attaching Hand Strap

Attach hand strap as shown:

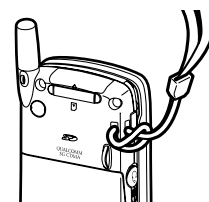

Opening and Closing the Handset

To turn the handset power on/off or use the keypad, slide handset open, as pictured on the right. Slide the cover until it clicks open. Close the handset cover when not in use.

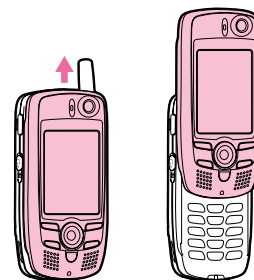

Tip

- Do not place labels on the back side of the handset cover. Labels may interfere when opening/closing the handset.
- The V801SA handset antenna does not extend. Do not pull on the antenna.

Incoming/Charging Lamp

Flashes to notify of incoming calls/mail. Flashes blue when Power Saving is on. Illuminates red while charging or when capturing still images.

Earpiece**Display****Soft Keys**

Function/action varies depending on operation (page 16-30).

Send/Talk/Off-hook Key

Makes and receives calls.

Menu Key

Accesses Main Menu or sub-menus.

Twin Speakers (3D Stereo)

Used during Hands-free TV Calls.

Clear Key

Deletes numbers/text or returns to the previous screen.

Memo Key

Records/plays Voice Memo or My Voice Memo, activates/cancels/plays Message Recorders. Also accesses symbols, pictographs or emoticons.

*** Key**

Enters asterisks and toggles upper/lower case.

Microphone**CCD Camera (Front Lens)**

Use to capture self-portraits.

Multi Selector

Selects menu items and moves the cursor.

Received Calls/Up

Opens Received Calls list or Received Mail list.

Redial/Down

Opens Redial list or Resend Mail list.

Phone Book/Left

Opens Phone Book.

Direct/Right

Accesses shortcut menus or functions saved for direct access.

End Key

Ends operations/actions.

Light Sensor

Detects ambient light to adjust keypad backlight.

Power/End Key

Turns handset power on/off. Also use as End Key to end operations/actions.

Keypad**# Key**

Enters #, ↵ (carriage return) or + for International calls.

External Connector

Connect Rapid Charger, In-Car Charger (sold separately) or Vodafone Global Standard USB cable (sold separately). Cap it when not in use.

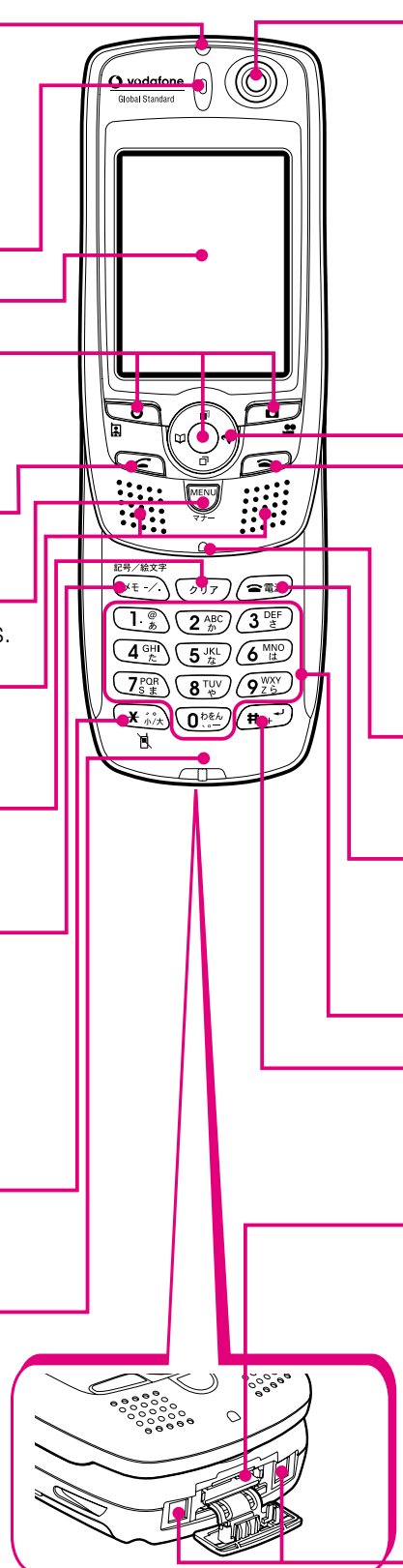
Charging Terminals

Charging the Battery

- Charge the battery before using the handset, for the first time or if the handset has not been used for a long time. Charging time may take longer than usual.
- Keep the battery terminal clean. The battery may not be charged properly if dust has accumulated on the terminal. Periodically wipe the battery terminal using a soft clean cloth.
- During charging, the battery may become warm. This is normal.
- The battery is a consumable item. If operating time becomes extremely short for practice use, replace the battery with a new one.
- Do not dispose of exhausted batteries with municipal waste. Tape over charger terminals beforehand and send it to a specified recycle collection or take it to a Vodafone shop.
- A lithium-ion battery is used in the V801SA handset. The battery cannot be fully charged in high or low temperatures. Charge the battery in temperature between 5-35°C.
- When a TV set or radio experiences interference or signal noise while the charger is being used, move the charger to another outlet away from the TV set or radio antenna.
- If the charging indicator does not appear while charging, a bad electrical contact or battery failure is the likely cause. Use a clean cloth to clean the battery terminal and then try again. If the charging indicator still does not appear, contact your nearest Vodafone shop.
- If you do not use the handset for a long time or you charge the battery that was left without charge after the battery replacement alarm sounds, **Crg** on Display may not blink. In this case, charging will start in several minutes unless the battery strength is exhausted or the battery does not work.
- Do not use the battery if it is damaged.

1 Connect Rapid Charger to Desktop Holder

2 Attach AC cable to Rapid Charger and plug into an AC outlet

3 Insert the handset into Desktop Holder

Charging starts. Charging Lamp lights red.

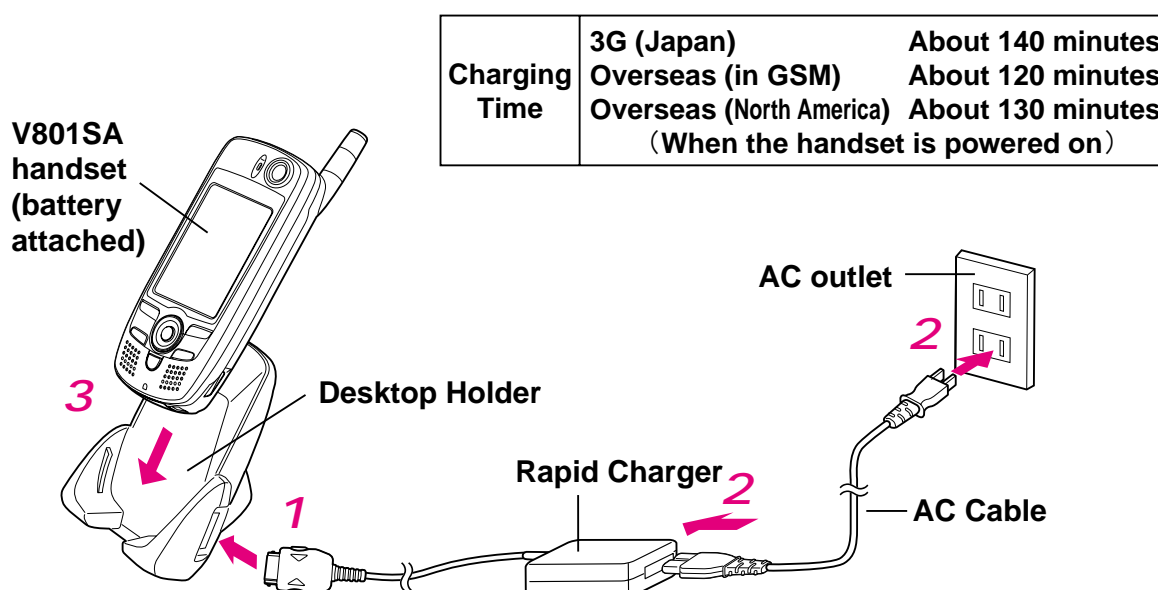

Tip

- Use Rapid Charger with a home use AC100-240V outlet only. Using an outlet other than specified may cause fire, or damage, overheating, ignition or failure of the charger.
- The AC cable is for use in Japan only. Do not use outside of Japan. To use the charger outside of Japan, purchase the appropriate AC cable for the country you are visiting.
- J-Phone and Sanyo shall not be liable for any damage caused by problems with charging the handset outside of Japan.
- Do not attempt to charge without a battery attached to the handset. This may cause equipment failure.
- Verify the handset is correctly aligned with Desktop Holder. Do not force the handset into Desktop Holder. Doing so may damage the handset or cause poor electrical contact.

Note

To connect Rapid Charger directly to the handset, flip open cap and plug into external connector, as shown in figure on the right.

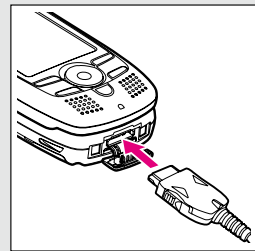

Display Indicators

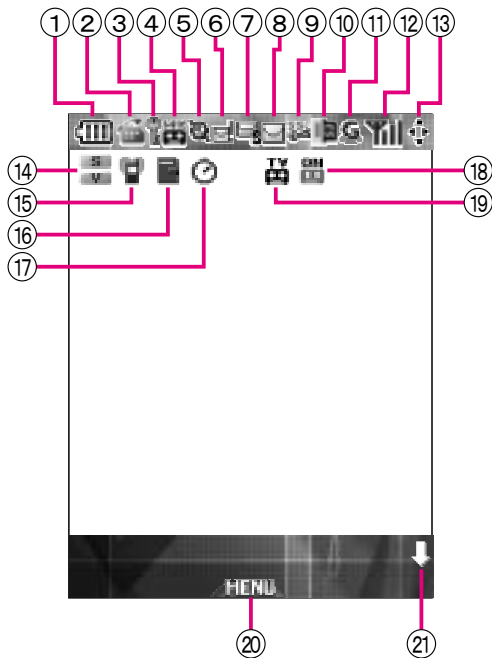

The handset's liquid crystal display employs high precision technology, however, please note that there may be instances where there are missing pixels or pixels that remain turned on.

① Battery Strength

- Level 3 Full
- Level 2 Moderate
- Level 1 Low
- Level 0 Charge immediately

Remaining charge is indicated. The rate at which the battery level decreases differs depending on the ambient temperature. Battery level will decrease faster in low temperatures.

Crg Charging

Battery is charging

② Voice Call

Voice Call is in progress

TV Call

TV Call is in progress

Music Playing



























Appears during audio playback

③ Secret Mode

Secret Mode is on

④ Voice Mail

There is a message at Voice Mail Center

- ⑤  **Java™ Activated**
 **Java™ Paused**
 Indicates Java™ application status
- ⑥ **Mail Server**
 **New Mail**
 There is new Mail on the server
 **Mail on the Server**
 Mail remains on the server
- ⑦  **SMS**
 There is unread SMS
- ⑧  **Mail**
 There is unread Mail
- ⑨  **SSL**
 Appears when browsing SSL/TLS Web contents
- ⑩  **Memory Card**
 Memory Card is installed
 Flashes green while reading or writing data and flashes red if the Memory Card's write-protect tab is set to LOCK
- ⑪  **GPRS**
 The handset is in GPRS area
 **Line Connection**
 Communicating with Vodafone live! Service Center
- ⑫ **Signal Strength**
 Weak  Low  Moderate
 Strong
 Indicates signal strength
Out of-Range
 Handset is currently out-of-range
 **Off-line Mode**
 Off-line Mode is set or signals cannot be sent/received during current function
 **IrDA Infrared**
 IrDA communication is in progress
- ⑬  **Scrolling**
 Indicates available scroll directions
- ⑭  **Silent Mode**
 Ring Tone Level is off
 **Vibration**
 Vibration for Voice Call is on
- ⑮  **(red) Silent Vibration**
 Silent Vibration Mode is set
 **Pochette Mode**
 Pochette Mode is set
 **(blue) Original Manner Mode**
 Original Manner Mode is set
 **Home Mode**
 Battery is charging and Home Mode is set
 **Driving Announcement**
 Driving Announcement is set
- ⑯  **Schedule**
 Schedule is set for the day
- ⑰  **Countdown Timer**
 Countdown Timer is set
- ⑱  **Message Recorders**
 Message Recorders is set
 **Message Recorders Full**
 There is no free space for recording new messages
- ⑲  **Unchecked Message on Message Recorders (TV Call)**
 **Unchecked Message on Message Recorders (Voice Call)**
 **Unchecked Message on Message Recorders (Voice Call and TV Call)**
- ⑳  **Sub-menu**
 Appears when sub-menus are available
 Press  to access sub-menus
- ㉑  **More Items**
 Scroll down for more information

Conventions Used in this Manual

Soft Keys and Menu Key

The V801SA handset employs Soft Keys. The function of a Soft Key changes according to the menu options. Each key corresponds to the function/action appearing above the key (as shown in picture on the right). An example of a typical Soft Key operation is described as follows:



Example:

To execute → Press

To execute → Press

To execute → Press

Press from Standby to access Main Menu.

Press when appears on the bottom of the display to open a sub-menu.

Access a variety of functions from sub-menus.

Multi Selector

Use of Multi Selector is described as follows:

Example: When appears, press up or down.

Selecting Items

Character input/insert position is indicated by and is referred to as the cursor.

Selected menu items are indicated by and . Scroll the cursor using

to select an item then press to execute the operation. Items preceded by

, , can also be selected by pressing the corresponding key (---).

or).

Display Illustrations

Display illustrations used in this manual are based on Taste Pattern 1 in Screen Taste. Some of the illustrations have been slightly modified from the actual appearance for better understanding.

Codes

Security Code, New Password and Center Access Code are required to use/access some functions/services. Do not forget these codes. Do not reveal your codes to others. J-Phone is not responsible for damages caused by misuse as a result of a third party's knowledge of these codes.

Security Code

Security Code protects private information and prevents unauthorized use of the handset by others. This code is required when accessing some handset functions. The code is initially set to "9999" or the 4-digit number selected at initial service subscription. The code can be changed from the handset.

New Password

New Password is used to set Call Barring Service for the V801SA handset. It is set to the 4-digit number selected at initial service subscription. The password can be changed from the handset. If the password is incorrectly entered three times consecutively, Call Barring Service settings will be locked and New Password and Center Access Code must be changed. For more information, contact Vodafone Customer Center (☎ page 16-60).

Center Access Code

Center Access Code is required when setting optional services (☎ page 16-56) from a landline. It is set to the 4-digit number selected at initial service subscription. To change the Center Access Code, contact Vodafone Customer Center (☎ page 16-60).



If you forget any of the codes/password, contact Vodafone Customer Center (☎ page 16-60).

PIN

Do not forget PIN 1 or PIN 2. You will not be able to access some functions. Do not reveal PINs to others. J-Phone is not responsible for damages caused by misuse as a result of a third party's knowledge of either PIN.

PIN 1

PIN 1 is a 4- to 8-digit code. It is set to "9999" by default. PIN 1 can be changed from the handset. When *PIN1 Setting* is set to On, PIN 1 must be entered when the handset is powered on.

PIN 2

PIN 2 is a 4- to 8-digit code required when resetting Call Time and Call Charge. It is set to "9999" by default. PIN 2 can be changed from the handset.

PIN Unlock Code

If a PIN is incorrectly entered three times consecutively, the PIN becomes invalid and the V801SA functions cannot be accessed. This is called a "PIN lock." To unlock the PIN, you must enter a PIN Unlock Code and set a new PIN. For further information, contact Vodafone Customer Center (☎ page 16-60). If a PIN Unlock Code is entered incorrectly ten times consecutively, the PIN cannot be unlocked. A new USIM Card will be issued for a fee.

Using PIN

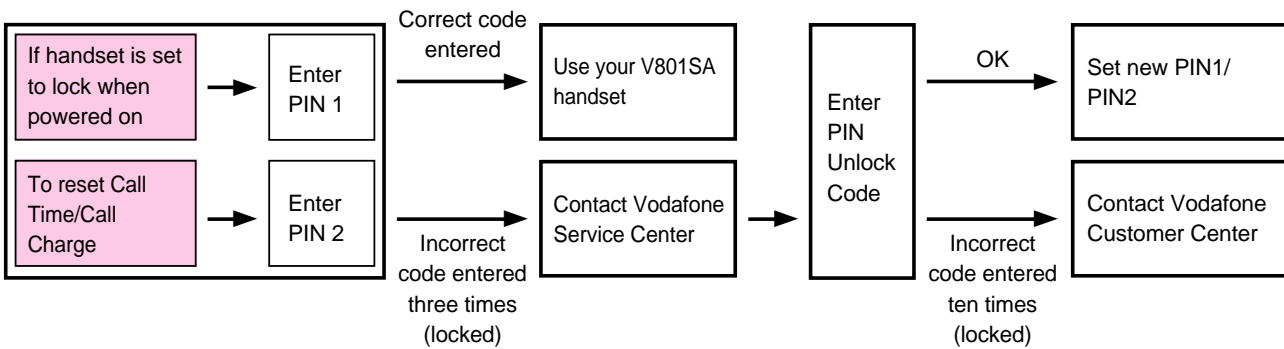

Basic Handset Operations

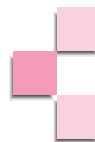

Handset Power On/Off

Press  for 1+ seconds

Retrieving Network Information

1 ネットワーク自動調整 appears

本機のご利用に必要な情報を取得します よろしいですか (Retrieve Necessary Information for This Handset, OK?) appears.

2 Use to choose *YES* and press **OK**



Selecting *NO* limits access to Vodafone live! services.

3 Use to select *English* and press **選択**

Transmission of User Information appears.



4 Use to choose *YES* and press **選択**



5 Press **OK**

Changing Display Language to English

1 Open *Language*

① Press  from Standby

② Use  to select  *F機能* (F-Function) and press  **OK**

③ Use  to select *設定1* (Settings 1) and press  **OK**

④ Use  to select *Language* and press  **OK**

2 Press **変更**

3 Use to select *English* and press **OK**

Displaying My Phone Number









1 Press from Standby

2 Use to select *F-Function* and press **OK**

- 3 Use  to select *Display My Phone Number* and press  **OK**

Setting Date & Time

1 Open *Set Clock*

- ① Press  from Standby
- ② Use  to select  *F-Function* and press  **OK**
- ③ Use  to select *Clock/Alarm* and press  **OK**
- ④ Use  to select *Set Clock* and press  **OK**

- 2 Press  **Change**









- 3 Use  to select *Set Clock* and press  **OK**

- 4 Enter the date, month, year and time and press  **OK**

Switching Between 3G/GSM Area Modes

The V801SA handset can be used in three area modes: a Japan mode and two overseas modes (GSM and North America). Switch area mode when using the handset outside Japan and select a service provider that is compatible for the area.

1 Open *Select Area*

- ① Press  from Standby
- ② Use  to select  *F-Function* and press  **OK**
- ③ Use  to select *Special Tools* and press  **OK**
- ④ Use  to select *Select Area* and press  **OK**

- 2 Press  **Change**

- 3 Use  to select *Select Area* and press  **OK**



- 4 Press  **Change**

- 5 Use  to select an area and press  **OK**

Japan: To use services in Japan.

Overseas (in GSM): To use GSM in the 900/1800 MHz band in Asia, Europe or Oceania, proceed to Step 6.

Overseas (North America): To use GSM in the 1900 MHz band in North America or Hawaii, proceed to Step 6.

- 6** Use  to select *Auto* or *Manual* and press  **OK**

Auto: A service provider for the area selected in Step 5 is automatically selected.

Manual: A service provider for the area selected in Step 5 is manually selected.
Proceed to Step 7.









- 7** Use  to select a service provider and press  **OK**

Making a Call

Enter a phone number and press 





Making an International Call

International calls can be made directly from the handset. Separate subscription required to use this service (No basic monthly charges or application fees required). For further information, call Vodafone Customer Center, General Information at 157 from a Vodafone handset or the number indicated for your subscription area in "Customer Service" ( page 16-60).

- 1** Enter a phone number from Standby
- 2** Press 
- 3** Use  to select *Add Country Number* and press  **OK**
- 4** Use  to select a country and press  **OK**
- 5** Use  to select *Send from Japan* and press  **OK**
- 6** Press 





Receiving a Call

- 1** A call arrives
- 2** Press 

Use any of these keys to answer a call:  , , key icon" data-bbox="704 741 744 756"/>, 

- 3** Press  to end the call

Calling from Redial List/Received Calls List































- 1** Press  (Redial) or  (Received Calls) from Standby
- 2** Use  to select an entry
- 3** Press  to make the call

Placing a Caller on Hold

- 1 A call arrives
- 2 Press 
- 3 Press  to start talking

Message Recorders and Voice Mail









Use Message Recorders and Voice Mail to record messages when you are unable to answer a call.

	Message Recorders	Voice Mail
Message Stored on:	The handset	Voice Mail Center (Server)
During a Call	Not Available	Available
When Out-of-Range	Not Available	Available
Recording Time	Up to 20 seconds for Voice Call and 15 seconds for TV Call per message	Up to three minutes per message
To Activate	Press  for 1+ seconds	1 Press  from Standby 2 Use  to select F-Function and press  3 Use  to select Services and press  4 Use  to select Voice Mail ¹ and press  5 Press  Execute 6 Use  to choose ON or OFF and press  ON: Ringer on OFF: Ringer off
To Activate/Forward while Ringing	Press 	Press  Forward
Message Indicators	 ,  or 	
To Check Messages	1 Press  from Standby 2 Use  to select a message and press  PLAY	1 Press  from Standby 2 Use  to select F-Function and press  3 Use  to select Services and press  4 Use  to select Play Voice Mail and press  5 Press  Change 6 Use  to select Play Voice Mail and press  7 Press  ²
Subscription	Not required	Required

1 Voice Mail cannot be accessed when Select Area is set to Overseas(in GSM) or Overseas(North America).
 2 The voice prompts are in Japanese. Contact Vodafone Customer Center for assistance in English (☎ page 16-60).

Call Forwarding

1 Open *Call Forwarding*

- ① Press  from Standby
- ② Use  to select  *F-Function* and press  **OK**
- ③ Use  to select *Services* and press  **OK**
- ④ Use  to select *Call Forwarding* and press  **OK**

2 Press **Execute**

3 Use to select *Voice Call* or *TV Call* and press **OK**

4 Enter a forwarding number

5 Press **OK**

6 Use to choose *ON* or *OFF* and press **OK**

ON: The handset rings before the call is forwarded. Proceed to Step 7.







OFF: The call is directly forwarded to the specified phone number. The handset connects to the network and Call Forwarding is set.

7 Enter Ring Time (05 to 30 seconds) and press **OK**

The handset connects to the network and Call Forwarding is set.

Total Call Time/Charges

1 Open *Time/Charges*

- ① Press  from Standby
- ② Use  to select  *F-Function* and press  **OK**
- ③ Use  to select *Time/Charges* and press  **OK**

2 Use to select *Time-Charges* and press **OK**

Manner Mode

Set Manner Mode when using the handset in places where the ring tone may disturb others.









Press  for 1+ seconds from Standby

Manner Mode is set.

To cancel Manner Mode, press  for 1+ seconds.

Selecting Manner Mode Type

1 Open *Manner Setting*





- ① Press  from Standby
- ② Use  to select  *F-Function* and press  **OK**
- ③ Use  to select *Settings 2* and press  **OK**
- ④ Use  to select *Manner Setting* and press  **OK**

2 Press **Change**

3 Use to select *Manner Setting* and press **Change**

4 Use to choose *ON* and press **OK**

5 Use to select a Manner Mode type and press **OK**

Manner Mode	Description
 <i>Silent Vibration</i>	Ring Tone Level is off. Vibration is on. All sounds are off.
 <i>Pochette</i>	Ring Tone Level is reduced. Vibration is on. Keypad Lock is on.
 <i>Original Manner</i>	Vibration is on. Customize maximum Ring Tone Level, Message Recorders (Voice Call/TV Call), Keypad Sound volume, Sound Effects volume and Alarm Sound settings.
 <i>Driving</i>	Ring Tone Level is off. Vibration is off. Message Recorders (Voice Call/TV Call) is on.

Entering Text

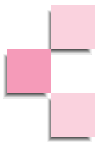

Input Mode

Seven input modes are available for entering text. From a text entry window, use the following procedure to select text input mode.

Example: Phone Book Name entry field

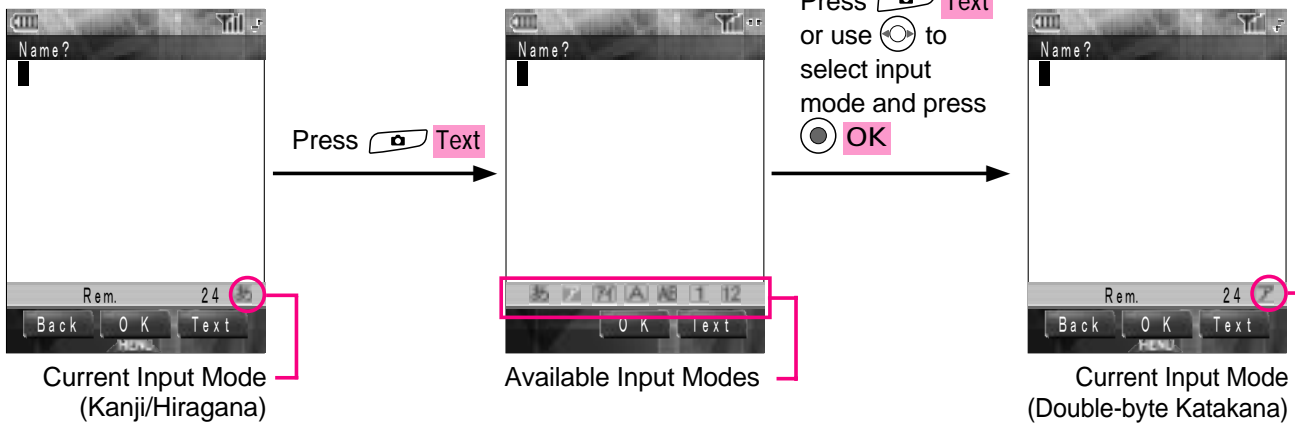

Input Modes:

- Kanji/Hiragana
- Double-byte Katakana
- Single-byte Katakana
- Double-byte Roman Letters (Upper/Lower Case)
- Single-byte Roman Letters (Upper/Lower Case)
- Double-byte Numbers
- Single-byte Numbers

Key Assignments

Input Mode Key	Roman Letters (Single-byte/Double-byte)	Numbers (Single-byte/Double-byte)
	.@/: ³	1
	ABCabc	2
	DEFdef	3
	GHIghi	4
	JKLjkl	5
	MNOmno	6
	PQRSpqrs	7
	TUVtuv	8
	WXYZwxyz	9
	, - ³	0
	Toggles lower/upper case (Before character is fixed). ¹	
	Displays characters assigned on - in reverse order (Before character is fixed). Line feed (After character is fixed) ²	Line feed ²
	Opens Symbols/Pictographs/Emoticons List	
	Moves the cursor (■) up or down.	
	Moves the cursor (■) right or left.	
	Fixes character (Before character is fixed). Enters character (After character is fixed).	Enters character.
	Press to delete character highlighted by the cursor (■) or if the cursor is located at the end of the text, the character before the cursor. Press for 1+ seconds to delete all text following the cursor (■) or if the cursor is located at the end of text, all text.	

1 Except in single-byte/double-byte number input modes.

2 Insert a carriage return ↵ while writing mail messages, saving library or entering text on Web or Java™.

3 Available characters vary depending on the function.

Note

If two adjacent characters use the same key, press to move the cursor before entering the second character.



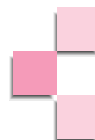





Phone Book



Phone Book Entry Items















Save frequently used phone numbers or e-mail addresses in Phone Book. Save up to 500 entries in the handset, 9999 to Memory Card and 50 to USIM Card.

Save/set the following in Phone Book:















Item		Description	Save to	
			Handset/Memory Card	USIM Card
–	Memory Number	Handset: 000 - 499 Memory Card: 0000 - 9998 USIM Card: 00 - 49	✓	✓
	Name	Enter up to 24 single-byte (12 double-byte) characters when saving entry to Handset/Memory Card and 12 single/double-byte characters for USIM Card.	✓	✓
	Reading	Enter up to 24 single-byte characters when saving entry to Handset/Memory Card and 12 single-byte characters for USIM Card.	✓	✓
	Phone Number	Enter up to 27 digits	✓ (Up to 3 numbers)	✓ (1 number)
–	Phone Type	Classify numbers into one of eight phone number types	✓	–
	E-mail Address	Enter up to 60 single-byte alphanumeric characters	✓ (Up to 2 addresses)	✓ (1 address)
	Group Number	Classify entries into one of ten groups	✓ (Up to 2 groups)	✓ (Up to 2 groups)
	Personal Ring Tone	Set personalized ring tone, incoming image, etc.	✓	–
	Address	Enter up to 128 single-byte (64 double-byte) characters	✓	–
	Memo	Enter up to 80 single-byte (40 double-byte) characters	✓	–
	Secret	Restrict access to entries	✓	–

Saving Information to Phone Book

Save a phone number, name and e-mail address as a new Phone Book entry.

- 1 Enter a phone number from Standby
- 2 Press  Save
- 3 Use  to select *Handset, USIM Card or Memory Card* and press  OK
The lowest available Memory Number is automatically selected.
- 4 Press  OK
- 5 Use  to select  (Name) and press  Edit
- 6 Enter a name and press  OK
- 7 Correct the reading as needed and press  OK
- 8 Use  to select  (E-Mail Address1) and press  Edit
- 9 Enter an e-mail address and press  OK
- 10 Press  Save







Editing Phone Book Entries

- 1 Press  from Standby
- 2 Press  Mode/
- 3 Use  to select *Phone Book Search* and press  OK
- 4 Use  to select a Phone Book entry and press  OK
- 5 Press  Details
- 6 Use  to select a field and press  Edit
- 7 Edit the entry and press  OK
- 8 Press  Save
- 9 Use  to choose *YES* or *NO* and press  OK

YES: Overwrite entry

NO: Save as new entry

Saving a Number from Received Calls



- 1 Press  from Standby
- 2 Use  to select a phone number and press 
- 3 Use  to select *Save Phone Book* and press  **OK**
- 4 Use  to select *New Entry* or *Add to Entry* and press  **OK**







New Entry: Save as a new Phone Book entry. Proceed to Step 3 on "Saving Information to Phone Book" (page 16-42).

Add to Entry: Add a phone number to an existing Phone Book entry. Proceed to Step 5.

- 5 Use  to select *Handset, USIM Card or Memory Card* and press  **OK**











Select Memory Card Data appears when *Memory Card* is selected. Use  to select a range of Memory Numbers and press  **OK**.











- 6 Use  to select a Phone Book entry and press  **OK**
- 7 Use  to select a field and press  **OK**
- 8 Enter other information as needed and press  **Save**
- 9 Use  to choose *YES* and press  **OK**

Dialing a Number from Phone Book

Searching by Memory Number

- 1 Press  from Standby
- 2 Press  **Mode/TV**
- 3 Use  to select *Memory Number Search* and press  **OK**
- 4 Enter a Memory Number
- 5 Press  **OK**
- 6 Press 
Press   to make a TV Call.

Searching by Reading

- 1 Press  from Standby
- 2 Press  **Mode/TV**
- 3 Use  to select *Name Search* and press  **OK**
- 4 Enter a reading and press  **Search**
- 5 Use  to select a Phone Book entry and press  **OK**
- 6 Press 
Press   to make a TV Call.

Note To use Name Search, a reading must be saved in Phone Book.

TV Call



TV Calls are available only in Japan.

Display Indicators during a TV Call

Rejecting Unwanted Calls

Appears when an unwanted call is being rejected

Hands-free ON

Lens in Use

Front Back

Your Image

Normal Image
Substitute Image
Image Paused
Image OFF

Image Quality

High Speed
Normal Speed
High Quality

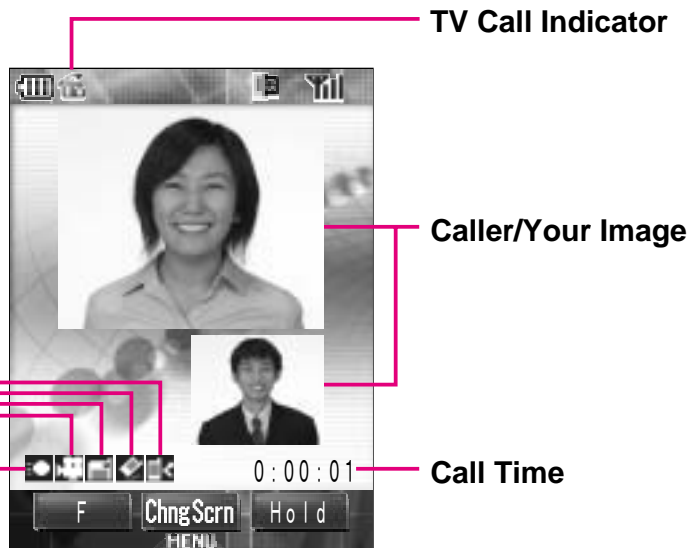

16

Abridged English Manual

Making a TV Call

- 1 Enter a phone number
- 2 Press
- 3 Press to end the call

Tip

TV Calls can be made to TV Call compatible Vodafone handsets.

Receiving a TV Call

- 1 The handset rings/vibrates and *Incoming TV Call* appears
- 2 Press **Answer** or :
: Receives TV Call. Your image is sent to the caller.
: Receives TV Call. Your image is not sent to the caller. Press -, , , or to also receive a TV Call.

Use **Change Screen** to toggle your image transmission on/off during a call.

- 3 Press to end the call



Using Camera

Before Using Camera

Image Quality and File Format

- The V801SA handset display supports 260,000 colors.
- The camera has a resolution of 310,000 pixels.
- Still images are saved as true color (about 16,770,000 colors) in JPEG format.
- Moving images are saved in MP4 format.

Clean the lens before shooting

- Unclean lens affects image quality. Wipe with a clean soft cloth before shooting.

CCD Camera

- The camera employs high precision technology but some pixels may seem brighter or darker than others.
- If the handset is left in a warm place (50-60°C) prior to shooting/saving images, image quality may be affected.

When Capturing Images

- Hold handset still when capturing images. Place handset on a stable surface when using Self-timer. Pictures captured with slightest handset movement may result in blurred images.
- Release the shutter after framing the subject. To prevent blurred images, hold handset still when releasing shutter.
- Bright light may cause streaks to appear in a picture. Use **Brightness** to avoid streaks. Streaks may not completely disappear.
- Maintain a distance of at least 30 cm from the subject.
- Make sure not to block the lens with your finger or hand strap.
- Shutter tone and video start/end tones sound even in Manner Mode. The volume cannot be altered.
- When Video Priority is on for Incoming Call Priority,  (Off-line Mode) appears and calls or Mail/SMS cannot be received until shooting ends.
- Do not flash directly into someone's eyes. Doing so may cause damage to the eyes. The flash is intended only as a supplement in dark places and is not as bright as a strobe light.
- Do not point the light close to someone's eyes. Avoid staring at the light when lit. Doing so may cause a loss of visual acuity.

Taking Pictures

Select from two modes and four sizes for capturing still images.

Shooting Mode	Frame Size	Save Size	Main Use
Mobile Camera	240 × 240 dots	QVGA 240 × 320 dots or 240 × 240 dots	Generally used for PDA. Use for handset wallpaper.
	176 × 144 dots (QCIF)	QCIF 176 × 144 dots	For sending images to mobile phones using Mail.
	144 × 144 dots	144 × 144 dots	
Digital Camera	VGA (Reduced to 3/8 or 1/2 size)	VGA 640 × 480 dots	Standard PC display size. Use to edit images saved in Memory Card or printing from PCs.





1 Open Camera

- ① Press  from Standby
- ② Use  to select  **Camera** and press  **OK**

2 Use to select *Mobile Camera* or *Digital Camera* and press **OK**

If *Digital Camera* is selected, a shooting screen appears. Proceed to Step 4.

3 Use to select a frame size and press **OK**

-  **Switch:** Press to switch between front lens and back lens.
- : Use to zoom in 33 levels up to four times in Mobile Camera mode.
-  : Press to open Still Image Album.

4 Frame the shot and press **Shutter**

-  **Reshoot:** Press to re-take the shot.

5 Press **Record**

If 240 × 240 was selected in Step 3, use  to select *Full (240 × 320)* or *Normal (240 × 240)* and press  **OK**.

The image is saved in Data Folder.

Shooting Videos

Select from three modes for shooting videos.

Video Mode	Frame Size (Save Size)	Video Quality	Main Use
Movie Sha-mail (30 Kbytes)	SubQCIF 128 × 96 dots or QCIF 176 × 144 dots	Normal	Send videos to mobile phones as Mail attachments (30 Kbytes or 200 Kbytes).
Movie Sha-mail (200 Kbytes)	SubQCIF 128 × 96 dots or QCIF 176 × 144 dots	High Quality Fine Normal	Shooting time varies according to shooting condition. Telop can be set on videos only for Movie Sha-mail (200 Kbytes).
Long-time Mode	SubQCIF 128 × 96 dots or QCIF 176 × 144 dots	High Quality Fine Normal	Shoot up to 1 Mbyte of file size.

1 Open Camera

① Press  from Standby

② Use  to select  **Camera** and press  **OK**

2 Use  to select **Movie** and press  **OK**

3 Use  to select a video mode and press  **OK**

4 Use  to select a frame size and press  **OK**

 **Switch:** Press to switch between front lens and back lens.



: Use to zoom in 17 levels up to two times

 : Press to open Video Image Album.

5 **Frame the shot and press**  **REC**

 **Switch:** Switches between front lens and back lens when the handset is open.

6 **Press**  **STOP**

 **PLAY:** Press to play captured video. Use  to adjust the volume during playback.

 **Reshoot:** Press to re-take the shot.

7 **Press**  **Record**

The video is saved in Audio & Video.

Audio & Video

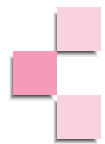

Play video and audio files saved to Video Player and Audio Player. Audio files downloaded from the Web or recorded on the handset are saved to Audio Player and video files downloaded from the Web or videos shot using handset are saved to Video Player.

The following file formats are compatible with Video and Audio Players:

	Video Player	Audio Player
File Format	MP4	AAC, MP3



- Audio & Video cannot be opened unless the valid USIM Card is inserted.
- The V801SA handset is incompatible with User Playlists created with a User Playlist compatible device.

User Playlist allows recording and playing tracks in groups. Playing within a group can be arranged in any order. The V801SA handset records and plays all tracks in a single list and the order cannot be rearranged.

Memory Cards

SD memory cards can be used with the V801SA handset. Save images captured using the handset camera and sound recorded using Voice Recorder. SD memory cards are referred to as Memory Cards in this manual.

Memory structure in Memory Card is as follows:

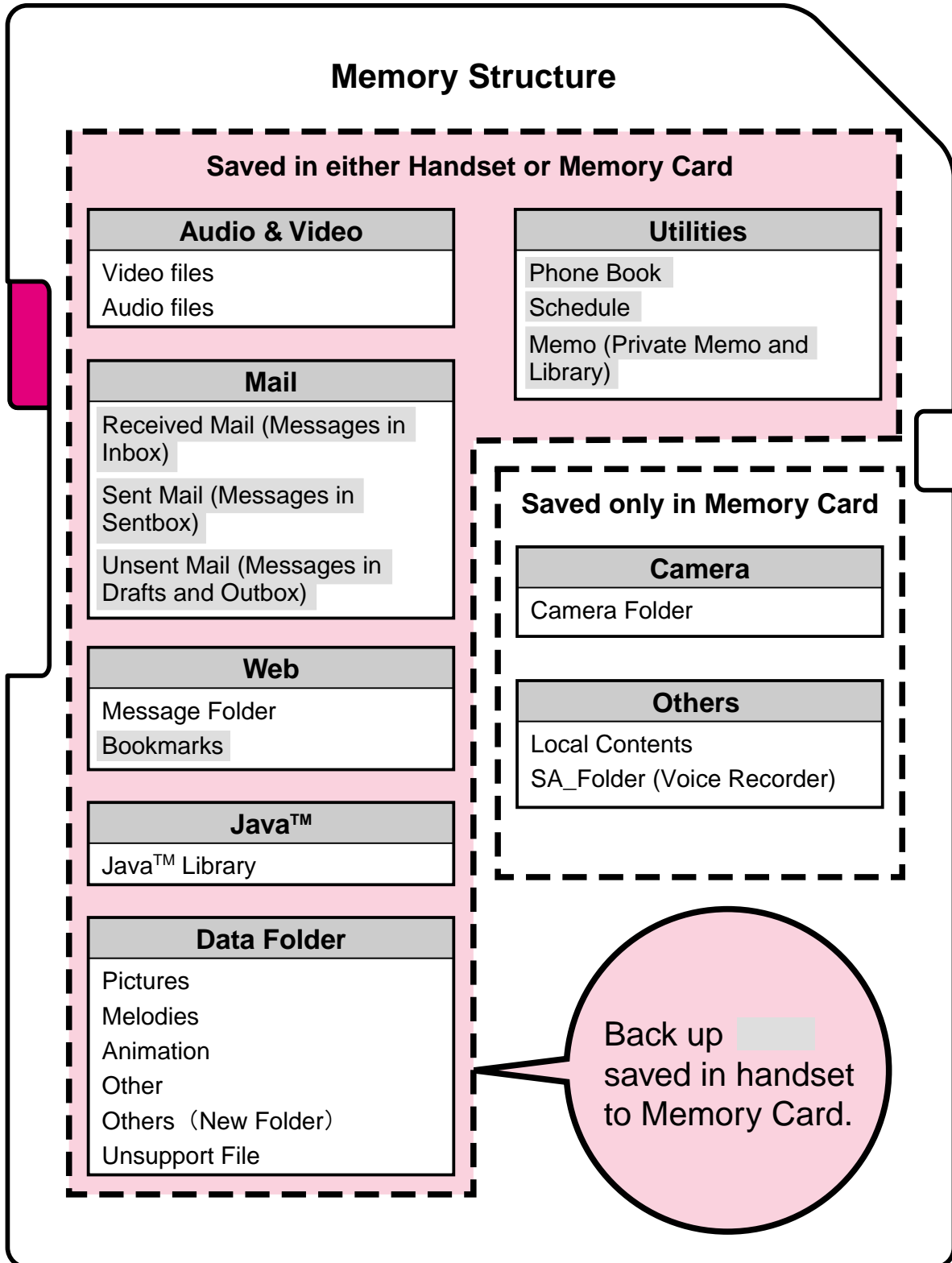

Before Using a Memory Card

Data Loss

- J-Phone shall not be liable for any damages resulting from the loss or alteration of data due to accident or equipment failure whether caused by connected devices or not, claimed by you or a third party.

Notes for Handling

- Do not insert or remove a Memory Card while the handset power is on.
- Do not detach the manufacturer's label. Doing so may result in damage to the Memory Card or data corruption.
- Do not attach new labels. Memory Cards are very thin and precision made. Labels may cause loose contact, and corruption or loss of data.
- Use an oil felt tip pen when writing on a Memory Card. Do not use a pencil or a ball-point pen. Doing so may result in damage to the Memory Card or data corruption.
- Always store a Memory Card in its case after removing it from its slot.
- Do not disassemble or modify the card.
- Do not bend, drop, moisten or apply impact to a Memory Card.
- Do not touch metal parts with your hand or metal objects.
- Do not use or store a Memory Card in the following places:
In high temperatures, such as a hot car or the scorching sun; in direct sunlight; in high humidity; with lots of dust or with corrosive gasses.

Data Protection

- Use the write-protect tab to prevent accidental erasure of data. Slide the write-protect tab to the lock position to disable deleting or overwriting data.
- Always make backups of important data.
- Never remove a Memory Card or turn the handset off while reading or writing data. Do not remove a battery from a handset that uses the battery as its power source while reading or writing data. Doing so may lead to data corruption (loss).
- Memory Cards have limited lifetimes. After a Memory Card has been used for a long time, it may not be possible to write new data to it.
- Some sound recordings are protected by copyright. Their use is prohibited except as authorized by the copyright owner.

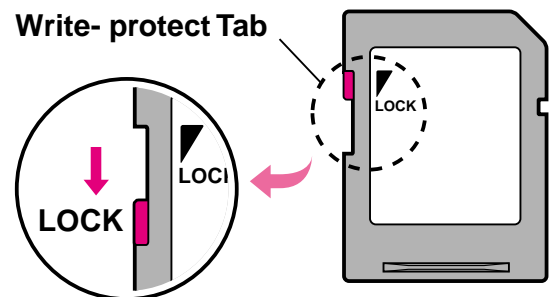

Other Notes

- Use only recommended Memory Cards (16, 32, 64, 128 or 256 Mbytes SD Memory Cards). Memory Cards other than these may not work. Multi-Media Cards are not supported.
- Memory size written on the labels of Memory Cards includes the space used to protect and manage copyrights as well as standard memory space.
- Memory Cards formatted with other devices may not properly work with the V801SA handset.

Inserting/Removing a Memory Card

Always turn the handset power off before inserting/removing Memory Card.

Inserting Memory Card

1 Open Memory Card Slot cover

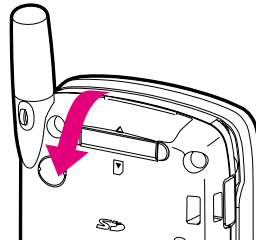

2 Position the Memory Card as shown and carefully push in until it clicks

Before inserting Memory Card, ensure that the card is aligned with the slot to avoid breakage of the card or the handset.

The figure on the right shows the correct position of the Memory Card.

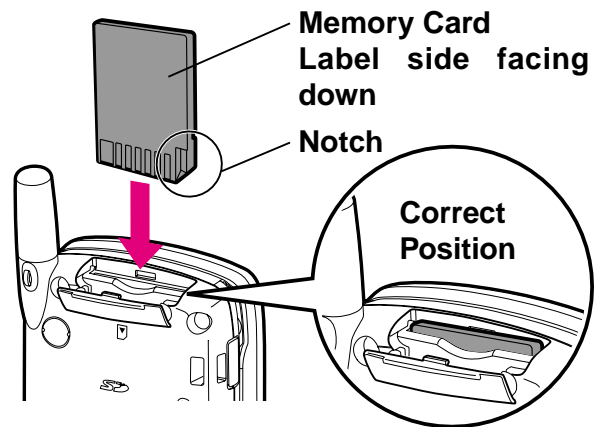

3 Close the cover

Removing Memory Card

1 Open Memory Card Slot cover

2 Gently press the Memory Card until it clicks

Release finger and the Memory Card will eject.

3 Pull out the Memory Card straight

4 Close the cover

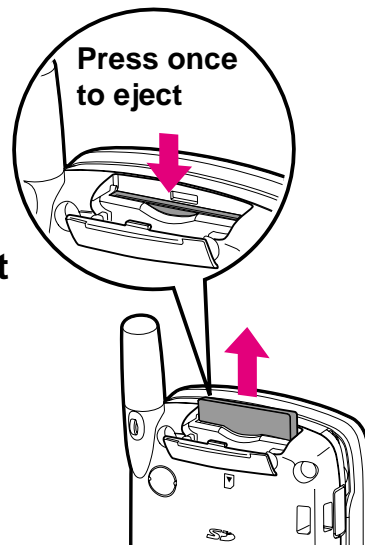

Data Folder



Created or downloaded data are automatically sorted and saved in one of six folders depending on the file format.

Folder Type	Description/File Format
Camera	Sha-mail Data Short cut folder to Picture Folder.
	Movie Sha-mail Data Short cut folder to lists of all video track of Audio & Video (page 16-49).
	Digital Camera Data Short cut folder to Camera Folder of Album (still images).
Pictures	PNG(.png, and .pnz)
	JPEG(.jpg, .jpe, .jpeg, and .jrz)
Melodies	Melody: SMD (.smd, .smz and .smx)
	SMAF, 40 Chord SMAF(.mmf)
Animation	PNG Animation, JPEG Animation, PNG/JPEG Animation: MTN(.mtn)
	MNG(.mng)
Other	vSeries Files <ul style="list-style-type: none"> vCard(.vcf) vCalendar(.vcs) vBookmark(.vbm) vMessage(.vmg) vNote(.vnt)
	Nancy(.noa)
	ZIP(.zip)
	TEXT(.txt)
	HTML/XHTML(.htm, .html, .xml, .xhtml)
	EML(.eml)
	Not Supported (.???, None)
	Dictionary (.wnn)
	Dictionary (.wnn)
	Dictionary (.wnn)

Data Folder Structure

Data Folder is organized in three layers. Six default folders are provided as shown below. Create new folders or sub folders (except in Camera Folder). Folders cannot be created in layer 3. Create folders to organize files. Save up to 7 Mbytes of data in the handset.

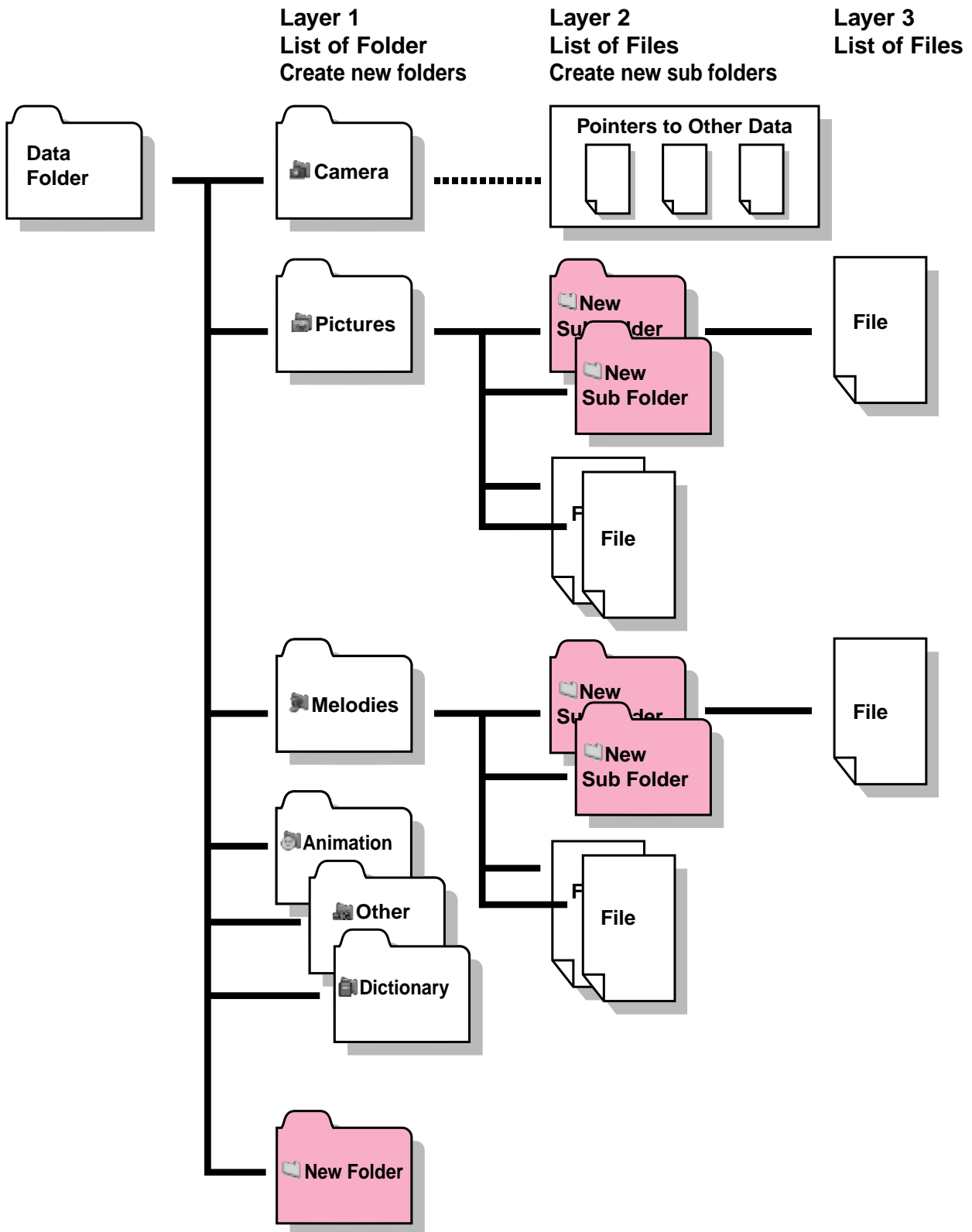

IrDA Infrared Data Communication

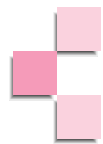

Send or receive Phone Book, Schedule and Mail/SMS data or Data Folder and Audio & Video files with other V801SA handsets, mobile phones or PCs with infrared data ports.

There are three types of IrDA data communication:

Communication via IrDA	Description
Send via IrDA	Select <i>Send via IrDA</i> from a sub-menu of each option to send data. For a batch transfer, select <i>Send All via IrDA</i> from Send via IrDA menu.
Receive via IrDA	Select <i>Receive via IrDA</i> from Send via IrDA menu to receive one file at a time.
Card Exchange	Exchange Owner Profile with other V801SA handsets. Select <i>Card Exchange</i> from Send via IrDA menu to send/receive Owner Profile.

16

Send and receive the following data and files via IrDA communication. Data stored in a Memory Card or data prohibited from transfer cannot be sent. vBookmark files and Video files in Audio & Video can be received but not sent.

Data/File	File Format	Data/File	File Format
Phone Book, Owner Profile	vCard	Library, Private Memo	vNote(TEXT)
Schedule	vCalendar	Original Ring Tone	SMAF
Bookmarks	vBookmark	Files in Data Folder	—
Mail/SMS in Mailbox	vMessage	Video files in Audio & Video	—

Notes for IrDA Communication

- Place sending and receiving Infrared ports within 20 cm before starting communication.

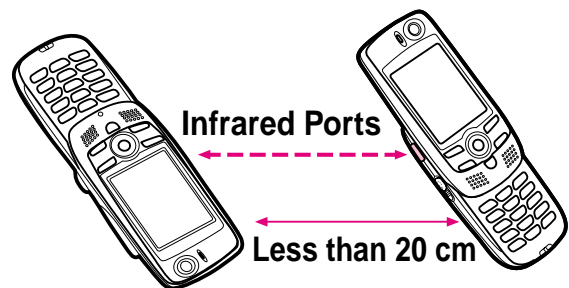

- Place devices on a stable surface, with their infrared ports aligned facing each other.
- Do not block the infrared port, with any objects such as hand strap during IrDA communication.
- Do not move the devices until data communication is finished.
- Communication may not work properly in direct sunlight or fluorescent light or near another infrared device.
-  appears during IrDA communication. The handset is out-of-range or in Off-line Mode and other signals cannot be sent or received.
- IrDA communication with V801SA handset is in accordance with IrMC1.1. Some data may not be sent or received depending on the application in use, even if the other device is in accordance with IrMC1.1.
- IrDA communication with V801SA handset is in accordance with IrDA.



Optional Services

The following optional services are offered:

Service	Description
Call Forwarding*	Forward incoming calls to a specified number
Voice Mail	Store messages at Voice Mail Center when the handset is out-of-range or a call is unanswered (except when Call Waiting Service is set)
Call Waiting	Place the caller on hold to take another incoming call or make another call
3 Way Calling	Add another party during a call and switch between parties or talking among three parties
Call Barring*	Restrict outgoing or incoming calls

* Call Forwarding Service and Call Barring Service cannot be set at the same time for Voice Call and TV Call. The service set previously is prioritized.

Out-of-Range

The V801SA handset and a base station exchange signals to set Call Forwarding, Voice Mail, Call Waiting and Call Barring Services. Services cannot be set, canceled or checked if the handset is out-of-range.

F-Functions

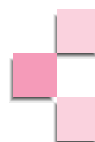

To access a function, press to select **F-Function**. Press **OK** and enter a function number. Or access functions by entering the following key sequences.

Key Sequence	Function	Description
0 わかん	Display My Phone Number ²	Display a phone number in USIM Card and Owner Profile
1. @ 0 わかん	Ring Tone Setting	Set Ring Tone Pattern, Ring Time or Incoming LED
1. @ 1. @	Ring Tone Level	Set ringer volume
1. @ 2 ABC か	Vibration	Set vibration on/off or select vibration pattern
1. @ 3 DEF き	Keypad Sound	Select keypad sound volume
1. @ 4 GHI た	Sound Effects	Select sound effects
1. @ 5 JKL な	Original Ring Tone	Compose your own ring tone
1. @ 6 MNO は	Call Vibration ¹	Set the handset to vibrate when your call or TV Call is answered
1. @ 7 PQR ま	Melody Volume	Set melody volume
1. @ 8 TUV や	Call Hold Setting ²	Set outgoing message played while callers are placed on hold
1. @ 9 WXY ら	TV Phone Connect Sound	Select sound effect and volume until a TV Call is answered
2 ABC か 0 わかん	Keypad Lock	Lock the handset
2 ABC か 1. @	Auto Key Lock ¹	Activate Keypad Lock when handset power is turned on
2 ABC か 2 ABC か	Secret Mode ¹	Set Secret Mode on/off
2 ABC か 3 DEF き	Phone Book Lock ¹	Prohibit Phone Book access
2 ABC か 4 GHI た	Restrict Dial ¹	Prohibit dialing calls from keypad
2 ABC か 5 JKL な	Reject Call ¹	Reject calls from numbers on Reject Call List
2 ABC か 6 MNO は	Reject No ID ¹	Reject incoming calls without Caller ID
2 ABC か 7 PQR ま	Clear Memory ¹	Delete all saved entries on the handset including Phone Book entries
2 ABC か 8 TUV や	Change Security Code ¹	Change Security Code
2 ABC か 9 WXY ら	Reset Defaults	Reset all settings
3 DEF き 0 わかん	Senior Setting ¹	Maximize display font and earpiece volume
3 DEF き 1. @	Confirm Memory ¹	Check Phone Book, Mail or Web memory status
3 DEF き 2 ABC か	Answer Setting ¹	Set Auto Answer
3 DEF き 3 DEF き	Power Saving	Set power saving display
3 DEF き 4 GHI た	Backlight ¹	Set display or keypad backlight
3 DEF き 5 JKL な	言語選択 (Language) ¹	Switch display language (Japanese and English)
3 DEF き 6 MNO は	Private Memo ¹	Save memos
3 DEF き 7 PQR ま	Flip Activation ¹	Connect/end calls by opening/closing the handset
3 DEF き 8 TUV や	Weak Signal Alert ¹	Set signal strength alert on/off
3 DEF き 9 WXY ら	Noise Cancellation ¹	Reduce effects of ambient noise to improve call quality
4 GHI た 0 わかん	Text Entry Help ¹	Save Library, User Dictionary or Predict Dictionary and set font type
4 GHI た 1. @	Message Recorders ²	Set options for Message Recorders and outgoing message played when unable to answer a call or TV Call
4 GHI た 2 ABC か	Standby Display ¹	Select image for Standby Display
4 GHI た 3 DEF き	Off-line Mode	Set send/receive signals off

Key Sequence	Function	Description
MENU 4 GHI た 4 GHI た	Manner Setting	Set Manner Mode settings
MENU 4 GHI た 5 JKL な	Screen Taste ¹	Set background color
MENU 4 GHI た 6 MNO は	3D Sound	Set Twin Speakers on/off
MENU 4 GHI た 7 PQR すま	Save Group Name ¹	Assign group names for Phone Book
MENU 4 GHI た 8 TUV や	Create Animation ²	Create animation with image files
MENU 4 GHI た 9 WXY ちら	Wallpaper/My CHARACTER ²	Set illustrations for Standby image, incoming calls, etc.
MENU 5 JKL な 0 わん ん	Schedule Control	Set Schedule, Special-days or Alarm
MENU 5 JKL な 1. @ あ	Auto Power ¹	Set Auto Power On/Auto Power Off
MENU 5 JKL な 2 ABC か	Display Calendar ¹	Display calendar
MENU 5 JKL な 3 DEF き	Countdown Timer	Set Countdown Timer
MENU 5 JKL な 9 WXY ちら	Set Clock ¹	Set date and time
MENU 6 MNO は 0 わん ん	Totals	Display or reset total call time and charge
MENU 6 MNO は 1. @ あ	Display Call Charge ¹	Set display call cost after each call on/off
MENU 6 MNO は 2 ABC か	Time-Charges	Display call time and cost for most recent call
MENU 6 MNO は 3 DEF き	Display Call Time ¹	Set display call time during a call on/off
MENU 7 PQR すま 0 わん ん	Call Barring	Set Call Barring Service
MENU 7 PQR すま 1. @ あ	Call Forwarding	Set Call Forwarding Service
MENU 7 PQR すま 2 ABC か	Voice Mail	Set Voice Mail Service
MENU 7 PQR すま 3 DEF き	Cancel	Cancel Call Forwarding/Voice Mail
MENU 7 PQR すま 4 GHI た	Status	Check Call Forwarding/Voice Mail status
MENU 7 PQR すま 5 JKL な	Call Waiting	Set Call Waiting Service
MENU 7 PQR すま 6 MNO は	Check Call Waiting	Check Call Waiting Service status
MENU 7 PQR すま 7 PQR すま	Play Voice Mail	Play Voice Mail messages and delete Voice Mail indicator
MENU 7 PQR すま 8 TUV や	3 Way Calling ³	Start 3 Way Call during a call
MENU 7 PQR すま 9 WXY ちら	Send with Code ¹	Save a code (including international code)/select Send with Code on/off
MENU 8 TUV や 0 わん ん	Calculator	Open Calculator
MENU 8 TUV や 1. @ あ	Petty Cash Book	Keep a balance of income and expenditure for last four months
MENU 8 TUV や 2 ABC か	Save Country Number	Save Country Number to Country Number List
MENU 9 WXY ちら 1. @ あ	Reconnection	Set reconnection method when the other party's phone is not TV Call compatible
MENU 9 WXY ちら 2 ABC か	Send Movie Image ¹	Set image quality for TV Call
MENU 9 WXY ちら 3 DEF き	Serial Connection	Switch between the V801SA and external device for making TV Call (Currently not available)
MENU 9 WXY ちら 4 GHI た	Change PIN	Change PIN1 or PIN2
MENU 9 WXY ちら 5 JKL な	PIN1 Setting	Set handset to lock when powered on
MENU 9 WXY ちら 6 MNO は	Substitute Image ¹	Set Substitute Image for TV Calls
MENU 9 WXY ちら 7 PQR すま	TV Auto Answer	Turn TV Call Auto Answer on/off and save entries to Auto Answer List
MENU 9 WXY ちら 8 TUV や	Select Area	Change settings for 3G or GSM area
MENU 9 WXY ちら 9 WXY ちら	Video Message Reply	Add to Message Reply List and set replying video messages
MENU # +	Function Guide	Display operation methods other than F-Functions

1 Can be operated in Standby or during Voice Call or TV Call.

2 Can be operated in Standby or during Voice Call.

3 Appears only when using Switch Line or 3 Way Calling.

Main Specifications

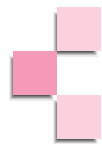

Weight	Approximately 146g	
Continuous call time	3G (Japan)	Approximately 170 minutes
	Overseas (in GSM)	Approximately 210 minutes
	Overseas (North America)	Approximately 210 minutes
Continuous standby time	3G (Japan)	Approximately 200 hours
	Overseas (in GSM)	Approximately 210 hours
	Overseas (North America)	Approximately 170 minutes
Size (W × H × D) mm	Approximately 51 × 108 × 26 (when closed)	
Maximum output	3G (Japan)	0.2W
	Overseas (in GSM)	2W / 1W
	Overseas (North America)	1W

- The above figures were calculated with the battery installed.
- Continuous call time is the average value calculated when talk status is maintained continuously in a stationary state in a place with a strong signal, a new fully charged battery installed.
- Continuous standby time is the average value calculated when standby status is maintained continuously in a stationary state in a place with a strong signal, without any calls or operations being performed. In weak signal conditions (i.e. inside buildings, in cars, in bags or out-of-range), standby time may be reduced by more than half. Standby time may also vary depending on such circumstances as temperature or condition when battery was charged.
- The number of service hours of the battery is the value calculated with stable signal reception. Talking in places where signals are weak and leaving the handset in standby while out-of-range consumes battery power and service hours may be reduced by more than half.
- Frequent use with backlight on (for Vodafone live! operation, etc.) will result in shorter continuous call time and continuous standby time.
- A portion of the software used in the product includes modules developed by Independent JPEG Group.

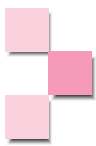

Customer Service

If you have any questions about a Vodafone handset or services, please call General Information. For service or repairs, please call Customer Assistance.

16



















Abridged English Manual

Vodafone Customer Centers

From a Vodafone handset, dial toll free at 157 for General Information or toll free at 113 for Customer Assistance

Call these Numbers Toll Free from a Fixed Line Phone:

Subscription Areas

Hokkaido	General Information	 0088-243-157
	Customer Assistance	 0088-243-113
Aomori · Akita · Iwate · Yamagata · Miyagi · Fukushima · Niigata	General Information	 0088-245-157
	Customer Assistance	 0088-245-113
Tokyo · Kanagawa · Chiba · Saitama · Ibaraki · Tochigi · Gunma · Yamanashi · Nagano	General Information	 0088-240-157
	Customer Assistance	 0088-240-113
Aichi · Gifu · Mie · Shizuoka	General Information	 0088-241-157
	Customer Assistance	 0088-241-113
Toyama · Ishikawa · Fukui	General Information	 0088-227-157
	Customer Assistance	 0088-227-113
Osaka · Hyogo · Kyoto · Nara · Shiga · Wakayama	General Information	 0088-242-157
	Customer Assistance	 0088-242-113
Hiroshima · Okayama · Yamaguchi · Tottori · Shimane	General Information	 0088-259-157
	Customer Assistance	 0088-259-113
Tokushima · Kagawa · Ehime · Kochi	General Information	 0088-247-157
	Customer Assistance	 0088-247-113
Fukuoka · Saga · Nagasaki · Oita · Kumamoto · Miyazaki · Kagoshima · Okinawa	General Information	 0088-250-157
	Customer Assistance	 0088-250-113