

## **APPENDIX A: SAR TEST DATA**

# PCTEST ENGINEERING LABORATORY, INC.

**DUT: SCP-PRO200 (Ver.I); Type: Cellular/PCS CDMA Phone with Bluetooth and EvDO  
Serial: A0000005FEE3A8**

Communication System: Cellular CDMA; Frequency: 836.52 MHz; Duty Cycle: 1:1  
Medium: 835 Brain ( $\sigma = 0.93$  mho/m,  $\epsilon_r = 40.78$ ,  $\rho = 1000$  kg/m<sup>3</sup>)  
Phantom section: Right Section

Test Date: 09-11-2007; Ambient Temp: 23.3°C; Tissue Temp: 21.2°C

Probe: EX3DV4 - SN3561; ConvF(7.94, 7.94, 7.94); Calibrated: 11/23/2006  
Sensor-Surface: 3mm (Mechanical Surface Detection)  
Electronics: DAE4 Sn649; Calibrated: 1/23/2007  
Phantom: SAM Main; Type: SAM 4.0; Serial: TP-1114  
Measurement SW: DASY4, V4.7 Build 53; Postprocessing SW: SEMCAD, V1.8 Build 172

## Cellular Band, Right Head, Touch, Mid.ch, Standard Battery

**Area Scan (6x15x1):** Measurement grid: dx=15mm, dy=15mm  
**Zoom Scan (5x5x7)/Cube 0:** Measurement grid: dx=8mm, dy=8mm, dz=5mm  
Reference Value = 3.23 V/m  
Peak SAR (extrapolated) = 0.526 W/kg  
**SAR(1 g) = 0.375 mW/g; SAR(10 g) = 0.229 mW/g**

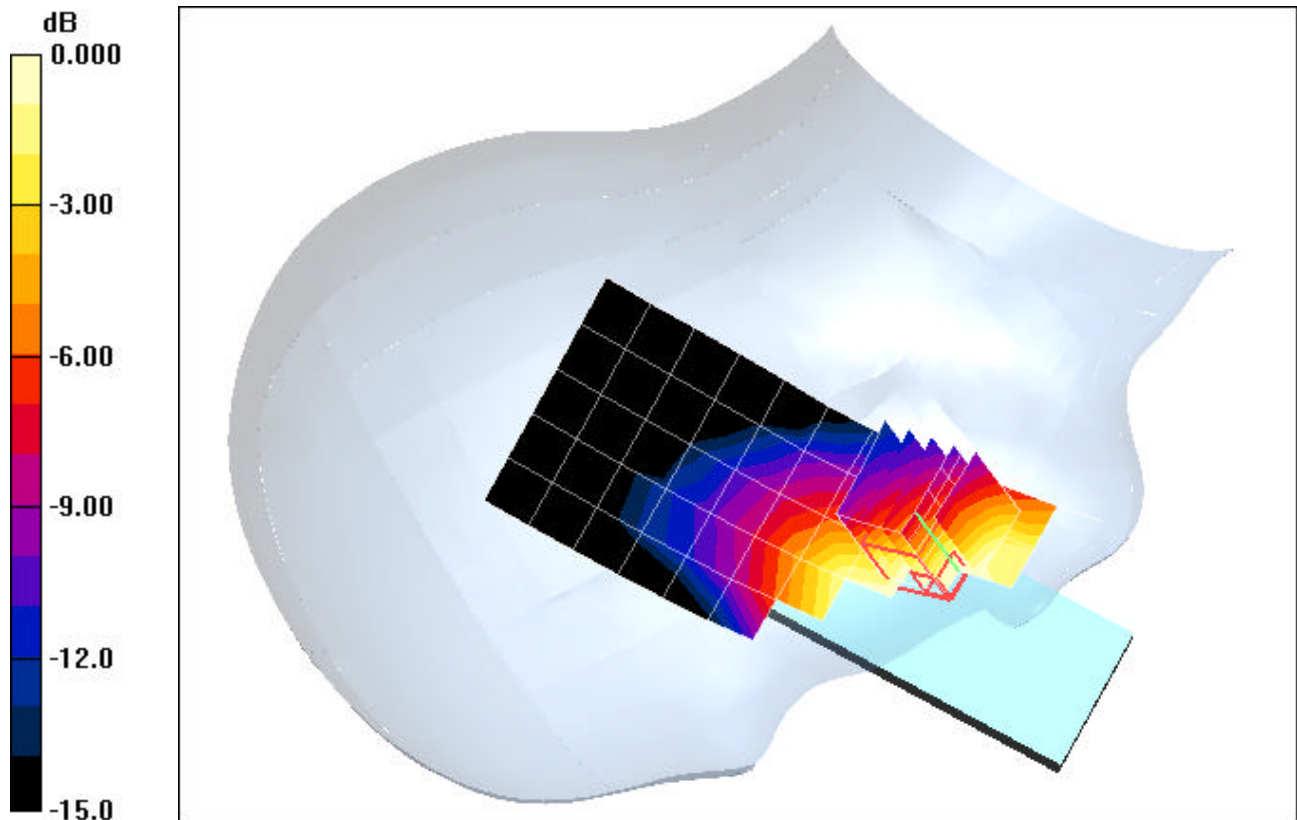

0 dB = 0.400mW/g

# PCTEST ENGINEERING LABORATORY, INC.

**DUT: SCP-PRO200 (Ver.I); Type: Cellular/PCS CDMA Phone with Bluetooth and EvDO  
Serial: A0000005FEE3A8**

Communication System: Cellular CDMA; Frequency: 836.52 MHz; Duty Cycle: 1:1  
Medium: 835 Brain ( $\sigma = 0.93$  mho/m,  $\epsilon_r = 40.78$ ,  $\rho = 1000$  kg/m<sup>3</sup>)  
Phantom section: Right Section

Test Date: 09-11-2007; Ambient Temp: 23.3°C; Tissue Temp: 21.2°C

Probe: EX3DV4 - SN3561; ConvF(7.94, 7.94, 7.94); Calibrated: 11/23/2006  
Sensor-Surface: 3mm (Mechanical Surface Detection)  
Electronics: DAE4 Sn649; Calibrated: 1/23/2007  
Phantom: SAM Main; Type: SAM 4.0; Serial: TP-1114

Measurement SW: DASY4, V4.7 Build 53; Postprocessing SW: SEMCAD, V1.8 Build 172

## **Cellular Band, Right Head, Tilt, Mid.ch, Standard Battery**

**Area Scan (6x15x1):** Measurement grid: dx=15mm, dy=15mm

**Zoom Scan (5x5x7)/Cube 0:** Measurement grid: dx=8mm, dy=8mm, dz=5mm

Reference Value = 7.21 V/m

Peak SAR (extrapolated) = 0.114 W/kg

**SAR(1 g) = 0.090 mW/g; SAR(10 g) = 0.068 mW/g**

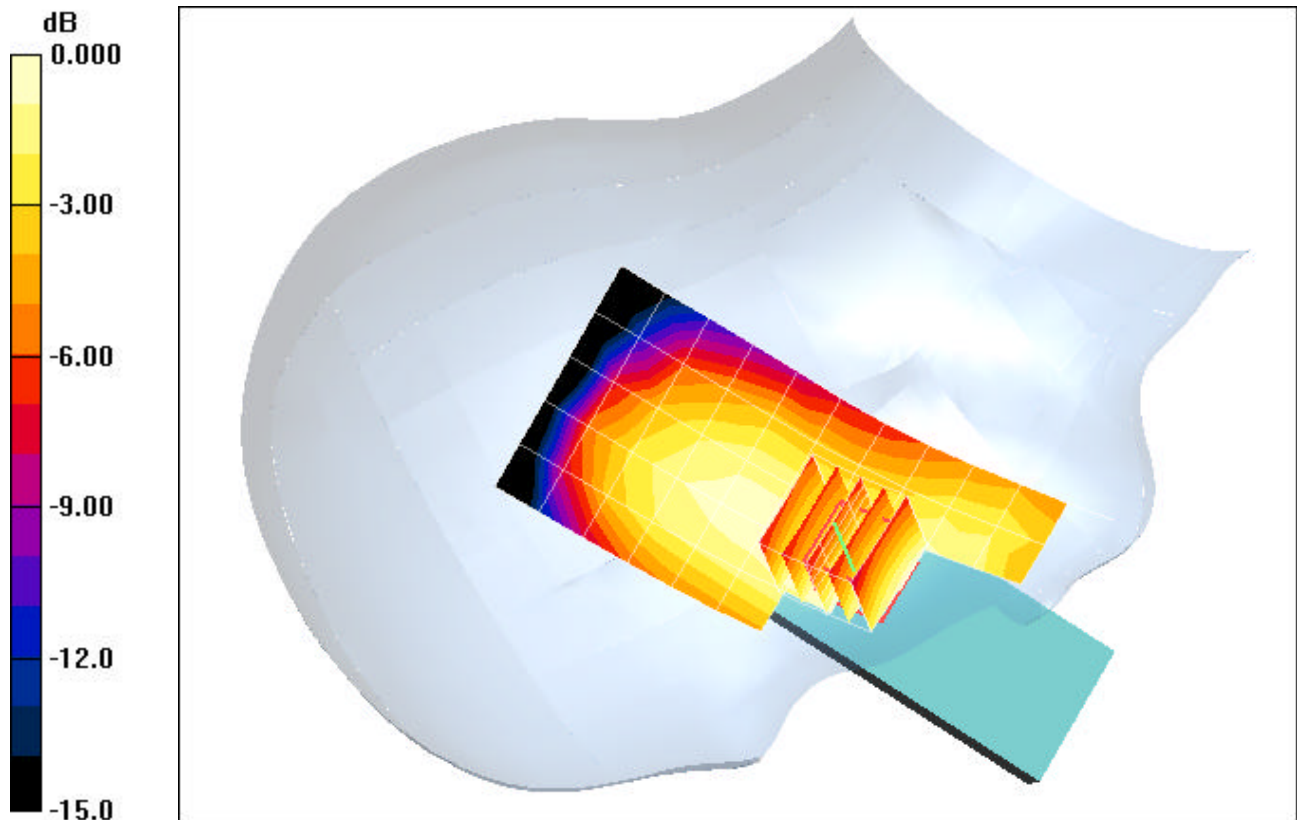

0 dB = 0.100mW/g

# PCTEST ENGINEERING LABORATORY, INC.

**DUT: SCP-PRO200 (Ver.I); Type: Cellular/PCS CDMA Phone with Bluetooth and EvDO  
Serial: A0000005FEE3A8**

Communication System: Cellular CDMA; Frequency: 836.52 MHz; Duty Cycle: 1:1  
Medium: 835 Brain ( $\sigma = 0.93$  mho/m,  $\epsilon_r = 40.78$ ,  $\rho = 1000$  kg/m<sup>3</sup>)  
Phantom section: Left Section

Test Date: 09-11-2007; Ambient Temp: 23.3°C; Tissue Temp: 21.2°C

Probe: EX3DV4 - SN3561; ConvF(7.94, 7.94, 7.94); Calibrated: 11/23/2006  
Sensor-Surface: 3mm (Mechanical Surface Detection)  
Electronics: DAE4 Sn649; Calibrated: 1/23/2007  
Phantom: SAM Main; Type: SAM 4.0; Serial: TP-1114  
Measurement SW: DASY4, V4.7 Build 53; Postprocessing SW: SEMCAD, V1.8 Build 172

## Cellular Band, Left Head, Touch, Mid.ch, Standard Battery

**Area Scan (6x15x1):** Measurement grid: dx=15mm, dy=15mm  
**Zoom Scan (5x5x7)/Cube 0:** Measurement grid: dx=8mm, dy=8mm, dz=5mm  
Reference Value = 3.01 V/m  
Peak SAR (extrapolated) = 0.533 W/kg  
**SAR(1 g) = 0.405 mW/g; SAR(10 g) = 0.289 mW/g**

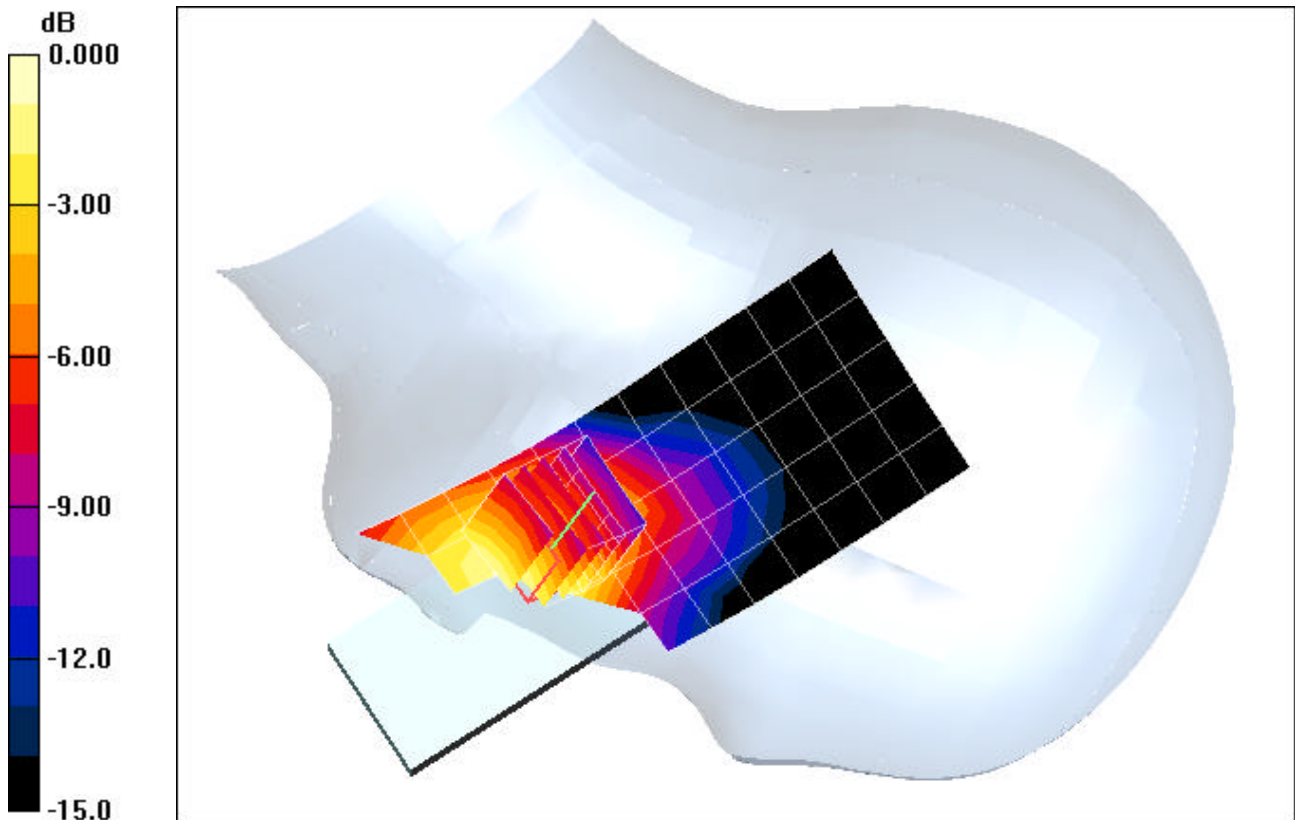

0 dB = 0.500mW/g

# PCTEST ENGINEERING LABORATORY, INC.

**DUT: SCP-PRO200 (Ver.I); Type: Cellular/PCS CDMA Phone with Bluetooth and EvDO  
Serial: A0000005FEE3A8**

Communication System: Cellular CDMA; Frequency: 836.52 MHz; Duty Cycle: 1:1  
Medium: 835 Brain ( $\sigma = 0.93$  mho/m,  $\epsilon_r = 40.78$ ,  $\rho = 1000$  kg/m<sup>3</sup>)  
Phantom section: Left Section

Test Date: 09-11-2007; Ambient Temp: 23.3°C; Tissue Temp: 21.2°C

Probe: EX3DV4 - SN3561; ConvF(7.94, 7.94, 7.94); Calibrated: 11/23/2006  
Sensor-Surface: 3mm (Mechanical Surface Detection)  
Electronics: DAE4 Sn649; Calibrated: 1/23/2007  
Phantom: SAM Main; Type: SAM 4.0; Serial: TP-1114  
Measurement SW: DASY4, V4.7 Build 53; Postprocessing SW: SEMCAD, V1.8 Build 172

## Cellular Band, Left Head, Tilt, Mid.ch, Standard Battery

**Area Scan (6x15x1):** Measurement grid: dx=15mm, dy=15mm  
**Zoom Scan (5x5x7)/Cube 0:** Measurement grid: dx=8mm, dy=8mm, dz=5mm  
Reference Value = 7.16 V/m  
Peak SAR (extrapolated) = 0.106 W/kg  
**SAR(1 g) = 0.086 mW/g; SAR(10 g) = 0.066 mW/g**

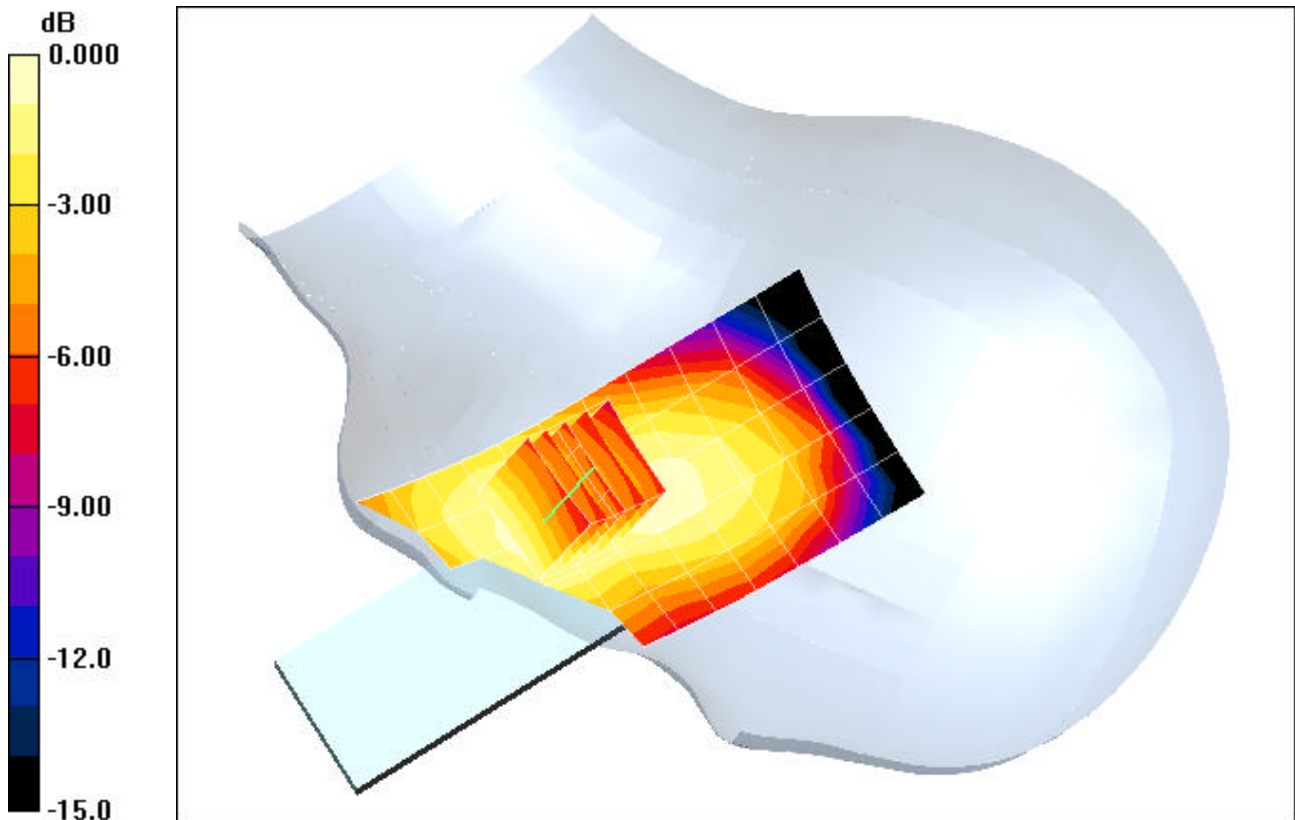

0 dB = 0.100mW/g

# PCTEST ENGINEERING LABORATORY, INC.

**DUT: SCP-PRO200 (Ver.I); Type: Cellular/PCS CDMA Phone with Bluetooth and EvDO  
Serial: A0000005FEE3A8**

Communication System: PCS CDMA; Frequency: 1880 MHz; Duty Cycle: 1:1  
Medium: 1900 Brain ( $\sigma = 1.33$  mho/m,  $\epsilon_r = 41.83$ ,  $\rho = 1000$  kg/m<sup>3</sup>)  
Phantom section: Right Section

Test Date: 09-11-2007; Ambient Temp: 23.3°C; Tissue Temp: 21.6°C

Probe: EX3DV4 - SN3561; ConvF(6.99, 6.99, 6.99); Calibrated: 11/23/2006  
Sensor-Surface: 3mm (Mechanical Surface Detection)  
Electronics: DAE4 Sn649; Calibrated: 1/23/2007  
Phantom: SAM Sub; Type: SAM 4.0; Serial: TP-1357  
Measurement SW: DASY4, V4.7 Build 53; Postprocessing SW: SEMCAD, V1.8 Build 172

## PCS Band, Right Head, Touch, Mid.ch, Standard Battery

**Area Scan (6x15x1):** Measurement grid: dx=15mm, dy=15mm  
**Zoom Scan (5x5x7)/Cube 0:** Measurement grid: dx=8mm, dy=8mm, dz=5mm  
Reference Value = 7.75 V/m  
Peak SAR (extrapolated) = 1.07 W/kg  
**SAR(1 g) = 0.702 mW/g; SAR(10 g) = 0.406 mW/g**

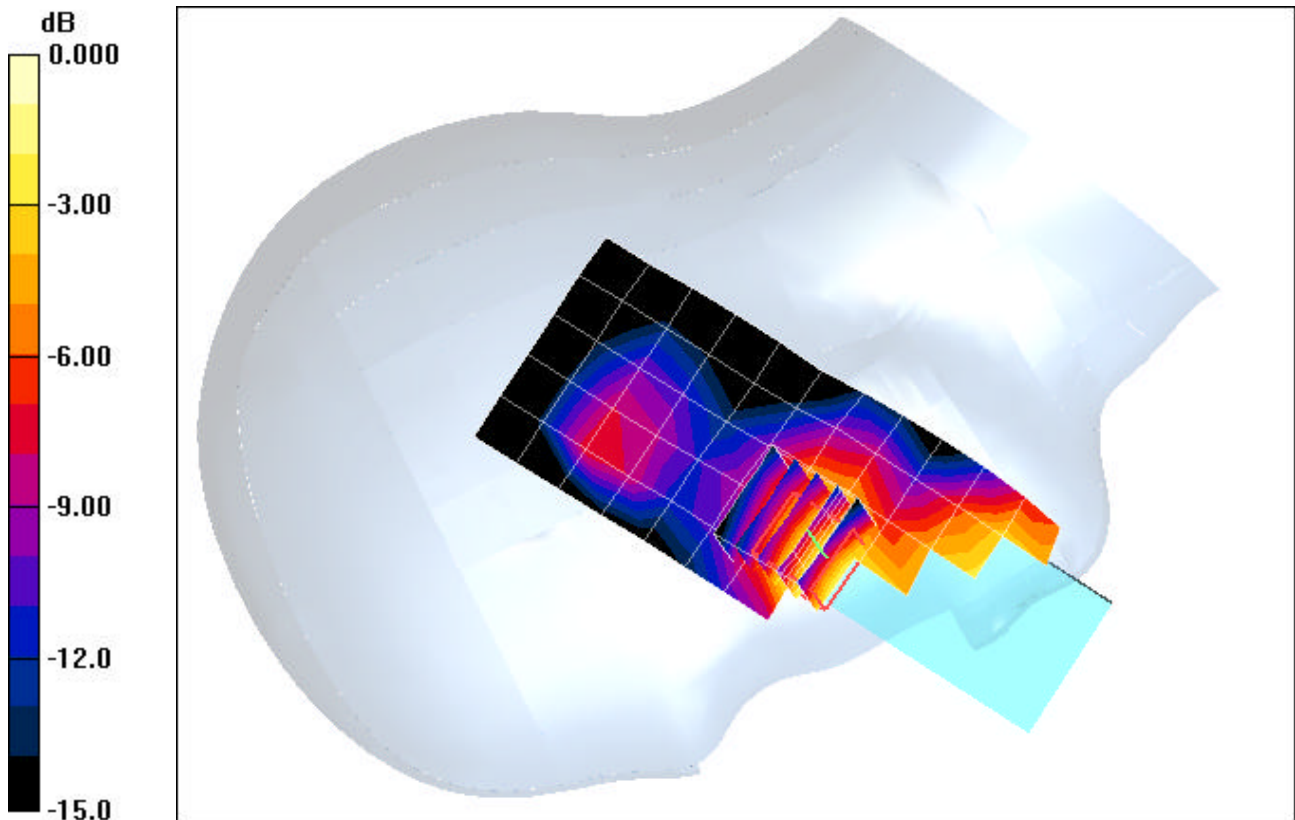

0 dB = 0.800mW/g

# PCTEST ENGINEERING LABORATORY, INC.

**DUT: SCP-PRO200 (Ver.I); Type: Cellular/PCS CDMA Phone with Bluetooth and EvDO  
Serial: A0000005FEE3A8**

Communication System: PCS CDMA; Frequency: 1880 MHz; Duty Cycle: 1:1  
Medium: 1900 Brain ( $\sigma = 1.33$  mho/m,  $\epsilon_r = 41.83$ ,  $\rho = 1000$  kg/m<sup>3</sup>)  
Phantom section: Right Section

Test Date: 09-11-2007; Ambient Temp: 23.3°C; Tissue Temp: 21.6°C

Probe: EX3DV4 - SN3561; ConvF(6.99, 6.99, 6.99); Calibrated: 11/23/2006  
Sensor-Surface: 3mm (Mechanical Surface Detection)  
Electronics: DAE4 Sn649; Calibrated: 1/23/2007  
Phantom: SAM Sub; Type: SAM 4.0; Serial: TP-1357  
Measurement SW: DASY4, V4.7 Build 53; Postprocessing SW: SEMCAD, V1.8 Build 172

## PCS Band, Right Head, Tilt, Mid.ch, Standard Battery

**Area Scan (6x15x1):** Measurement grid: dx=15mm, dy=15mm  
**Zoom Scan (5x5x7)/Cube 0:** Measurement grid: dx=8mm, dy=8mm, dz=5mm  
Reference Value = 13.3 V/m  
Peak SAR (extrapolated) = 0.528 W/kg  
**SAR(1 g) = 0.334 mW/g; SAR(10 g) = 0.193 mW/g**

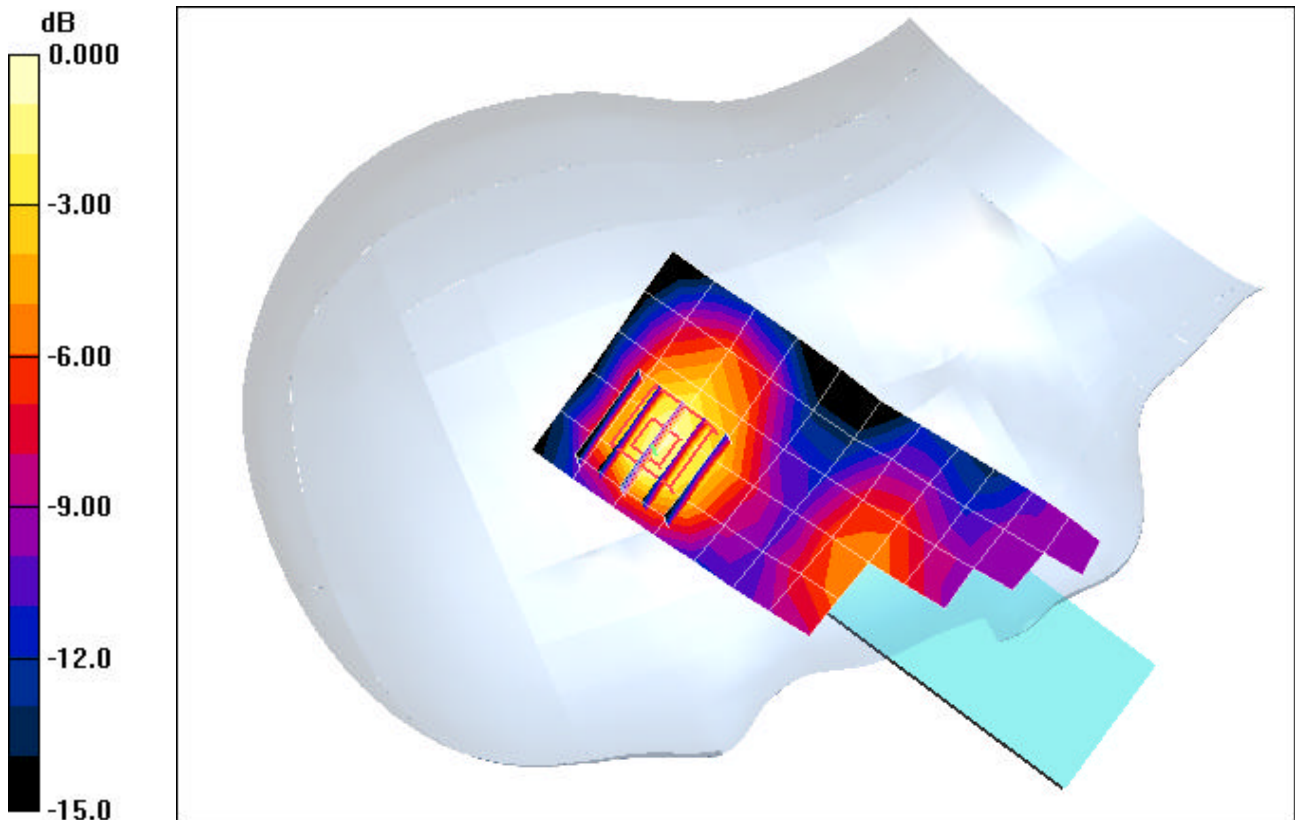

0 dB = 0.400mW/g

# PCTEST ENGINEERING LABORATORY, INC.

**DUT: SCP-PRO200 (Ver.I); Type: Cellular/PCS CDMA Phone with Bluetooth and EvDO  
Serial: A0000005FEE3A8**

Communication System: PCS CDMA; Frequency: 1908.75 MHz; Duty Cycle: 1:1  
Medium: 1900 Brain ( $\sigma = 1.33$  mho/m,  $\epsilon_r = 41.83$ ,  $\rho = 1000$  kg/m<sup>3</sup>)  
Phantom section: Left Section

Test Date: 09-10-2007; Ambient Temp: 23.5°C; Tissue Temp: 21.5°C

Probe: EX3DV4 - SN3561; ConvF(6.99, 6.99, 6.99); Calibrated: 11/23/2006  
Sensor-Surface: 3mm (Mechanical Surface Detection)  
Electronics: DAE4 Sn649; Calibrated: 1/23/2007  
Phantom: SAM Sub; Type: SAM 4.0; Serial: TP-1357  
Measurement SW: DASY4, V4.7 Build 53; Postprocessing SW: SEMCAD, V1.8 Build 172

## PCS Band, Left Head, Touch, High.ch, Standard Battery

**Area Scan (6x15x1):** Measurement grid: dx=15mm, dy=15mm  
**Zoom Scan (5x5x7)/Cube 0:** Measurement grid: dx=8mm, dy=8mm, dz=5mm  
Reference Value = 8.09 V/m  
Peak SAR (extrapolated) = 2.00 W/kg  
**SAR(1 g) = 1.21 mW/g; SAR(10 g) = 0.671 mW/g**

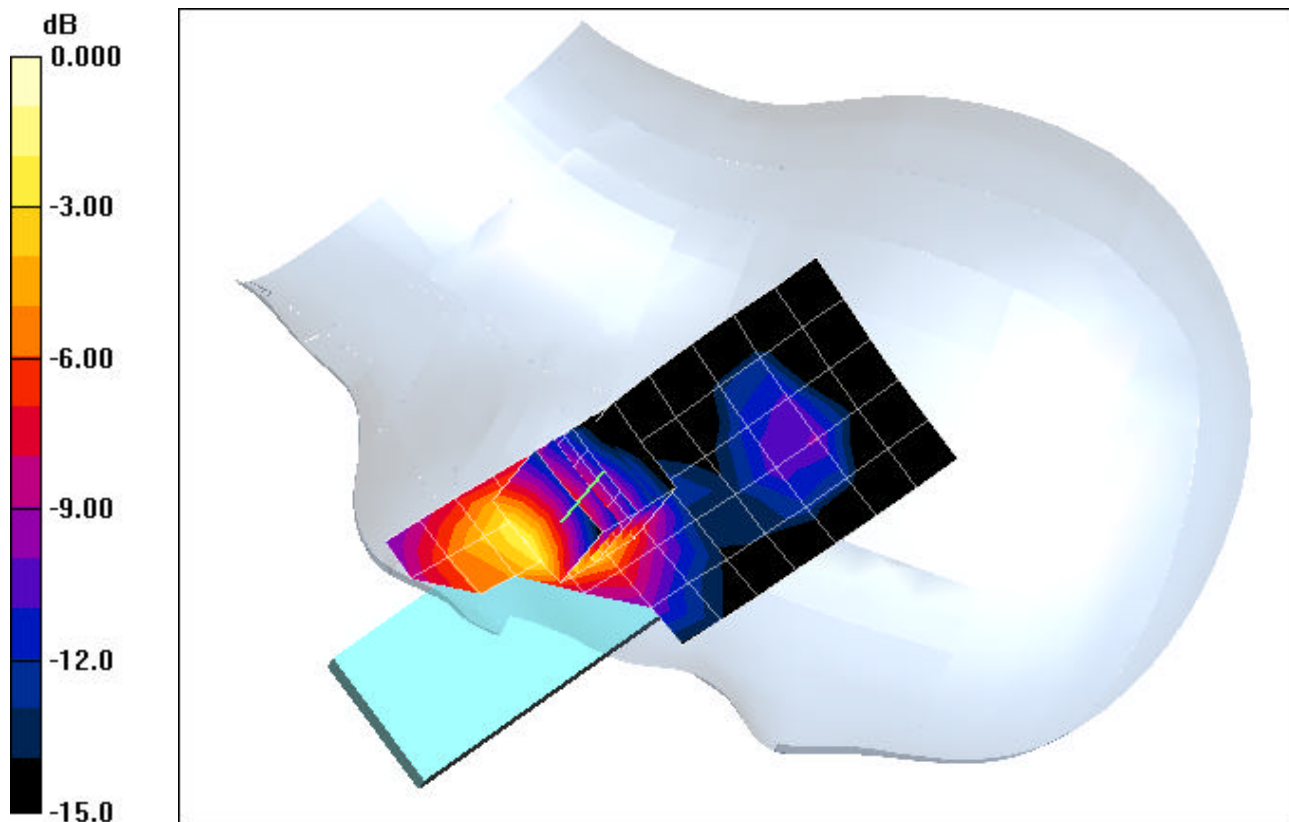

0 dB = 1.30mW/g



# PCTEST ENGINEERING LABORATORY, INC.

**DUT: SCP-PRO200 (Ver.I); Type: Cellular/PCS CDMA Phone with Bluetooth and EvDO  
Serial: A0000005FEE3A8**

Communication System: PCS CDMA; Frequency: 1880 MHz; Duty Cycle: 1:1  
Medium: 1900 Brain ( $\sigma = 1.33$  mho/m,  $\epsilon_r = 41.83$ ,  $\rho = 1000$  kg/m<sup>3</sup>)  
Phantom section: Left Section

Test Date: 09-10-2007; Ambient Temp: 23.5°C; Tissue Temp: 21.5°C

Probe: EX3DV4 - SN3561; ConvF(6.99, 6.99, 6.99); Calibrated: 11/23/2006  
Sensor-Surface: 3mm (Mechanical Surface Detection)  
Electronics: DAE4 Sn649; Calibrated: 1/23/2007  
Phantom: SAM Sub; Type: SAM 4.0; Serial: TP-1357  
Measurement SW: DASY4, V4.7 Build 53; Postprocessing SW: SEMCAD, V1.8 Build 172

## PCS Band, Left Head, Tilt, Mid.ch, Standard Battery

**Area Scan (6x15x1):** Measurement grid: dx=15mm, dy=15mm  
**Zoom Scan (5x5x7)/Cube 0:** Measurement grid: dx=8mm, dy=8mm, dz=5mm  
Reference Value = 11.5 V/m  
Peak SAR (extrapolated) = 0.335 W/kg  
**SAR(1 g) = 0.223 mW/g; SAR(10 g) = 0.144 mW/g**

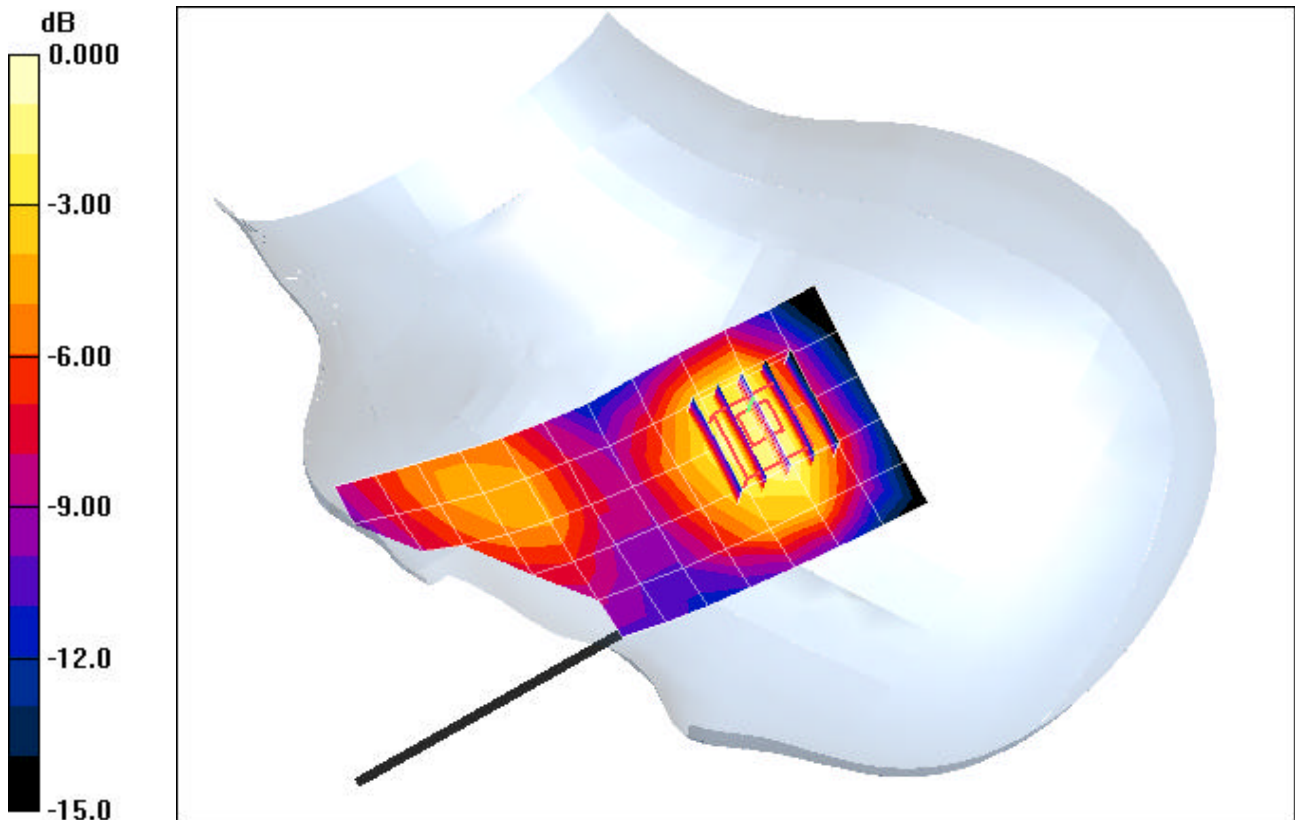

0 dB = 0.300mW/g

# PCTEST ENGINEERING LABORATORY, INC.

**DUT: SCP-PRO200 (Ver.I); Type: Cellular/PCS CDMA Phone with Bluetooth and EvDO  
Serial: A0000005FEE3A8**

Communication System: Cellular CDMA; Frequency: 836.52 MHz; Duty Cycle: 1:1  
Medium: 835 Muscle ( $\sigma = 1.00$  mho/m,  $\epsilon_r = 52.50$ ,  $\rho = 1000$  kg/m<sup>3</sup>)  
Phantom section: Flat Section; Tested with Holster

Test Date: 09-11-2007; Ambient Temp: 23.6°C; Tissue Temp: 21.4°C

Probe: EX3DV4 - SN3561; ConvF(7.92, 7.92, 7.92); Calibrated: 11/23/2006  
Sensor-Surface: 3mm (Mechanical Surface Detection)  
Electronics: DAE4 Sn649; Calibrated: 1/23/2007  
Phantom: SAM Main; Type: SAM 4.0; Serial: TP-1114  
Measurement SW: DASY4, V4.7 Build 53; Postprocessing SW: SEMCAD, V1.8 Build 172

## Cellular Band, Body SAR, Front side, Mid.ch, Standard Battery

**Area Scan (6x10x1):** Measurement grid: dx=15mm, dy=15mm  
**Zoom Scan (5x5x7)/Cube 0:** Measurement grid: dx=8mm, dy=8mm, dz=5mm  
Reference Value = 14.6 V/m  
Peak SAR (extrapolated) = 0.277 W/kg  
**SAR(1 g) = 0.218 mW/g; SAR(10 g) = 0.161 mW/g**

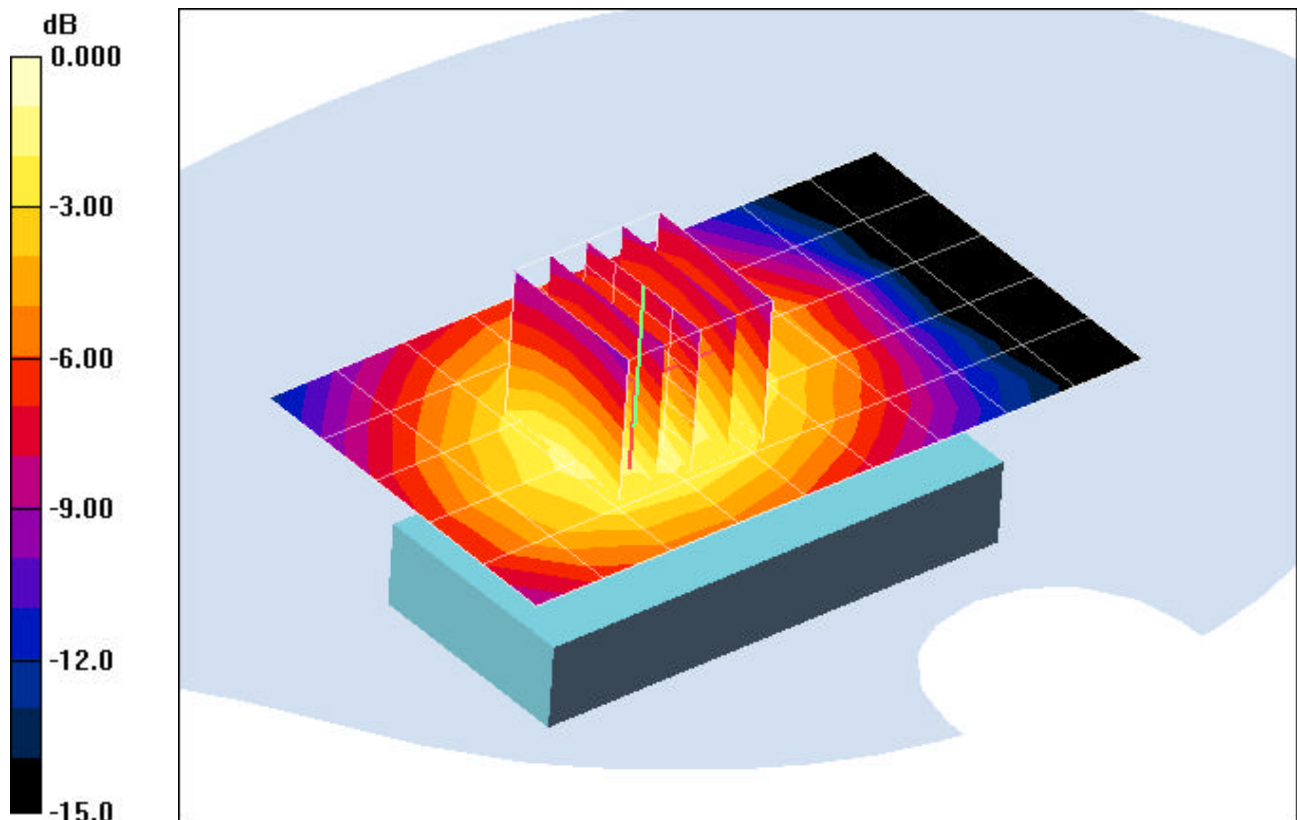

0 dB = 0.300mW/g

# PCTEST ENGINEERING LABORATORY, INC.

**DUT: SCP-PRO200 (Ver.I); Type: Cellular/PCS CDMA Phone with Bluetooth and EvDO  
Serial: A0000005FEE3A8**

Communication System: PCS CDMA; Frequency: 1880 MHz; Duty Cycle: 1:1

Medium: 1900 Muscle ( $\sigma = 1.58$  mho/m,  $\epsilon_r = 55.96$ ,  $\rho = 1000$  kg/m<sup>3</sup>)

Phantom section: Flat Section; Tested with Holster

Test Date: 09-11-2007; Ambient Temp: 23.8°C; Tissue Temp: 21.7°C

Probe: EX3DV4 - SN3561; ConvF(6.47, 6.47, 6.47); Calibrated: 11/23/2006

Sensor-Surface: 3mm (Mechanical Surface Detection)

Electronics: DAE4 Sn649; Calibrated: 1/23/2007

Phantom: SAM Sub; Type: SAM 4.0; Serial: TP-1357

Measurement SW: DASY4, V4.7 Build 53; Postprocessing SW: SEMCAD, V1.8 Build 172

## PCS Band, Body SAR, Front side, Mid.ch, Standard Battery

**Area Scan (6x10x1):** Measurement grid: dx=15mm, dy=15mm

**Zoom Scan (5x5x7)/Cube 0:** Measurement grid: dx=8mm, dy=8mm, dz=5mm

Reference Value = 14.1 V/m

Peak SAR (extrapolated) = 0.843 W/kg

**SAR(1 g) = 0.544 mW/g; SAR(10 g) = 0.335 mW/g**

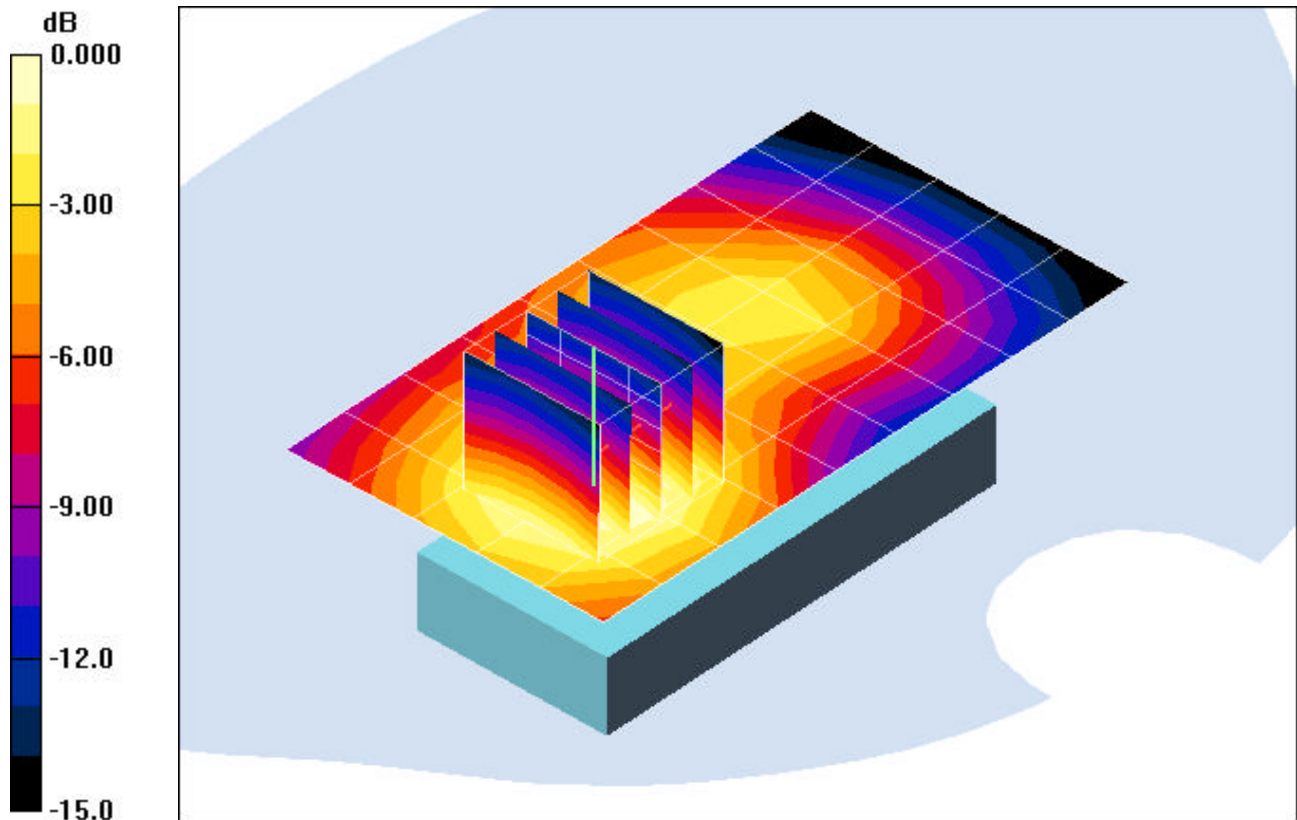

0 dB = 0.600mW/g

# PCTEST ENGINEERING LABORATORY, INC.

**DUT: SCP-PRO200 (Ver.I); Type: Cellular/PCS CDMA Phone with Bluetooth and EvDO  
Serial: A0000005FEE3A8**

Communication System: PCS CDMA; Frequency: 1880 MHz; Duty Cycle: 1:1  
Medium: 1900 Brain ( $\sigma = 1.33$  mho/m,  $\epsilon_r = 41.83$ ,  $\rho = 1000$  kg/m<sup>3</sup>)  
Phantom section: Flat Section; Space: 2.5 cm

Test Date: 09-11-2007; Ambient Temp: 23.3°C; Tissue Temp: 21.6°C

Probe: EX3DV4 - SN3561; ConvF(6.99, 6.99, 6.99); Calibrated: 11/23/2006  
Sensor-Surface: 3mm (Mechanical Surface Detection)  
Electronics: DAE4 Sn649; Calibrated: 1/23/2007  
Phantom: SAM Sub; Type: SAM 4.0; Serial: TP-1357  
Measurement SW: DASY4, V4.7 Build 53; Postprocessing SW: SEMCAD, V1.8 Build 172

## **PCS Band, Face SAR, PTT Mode, Flip open, Mid.ch, Standard Battery**

**Area Scan (6x15x1):** Measurement grid: dx=15mm, dy=15mm  
**Zoom Scan (5x5x7)/Cube 0:** Measurement grid: dx=8mm, dy=8mm, dz=5mm  
Reference Value = 6.64 V/m  
Peak SAR (extrapolated) = 0.515 W/kg  
**SAR(1 g) = 0.345 mW/g; SAR(10 g) = 0.224 mW/g**

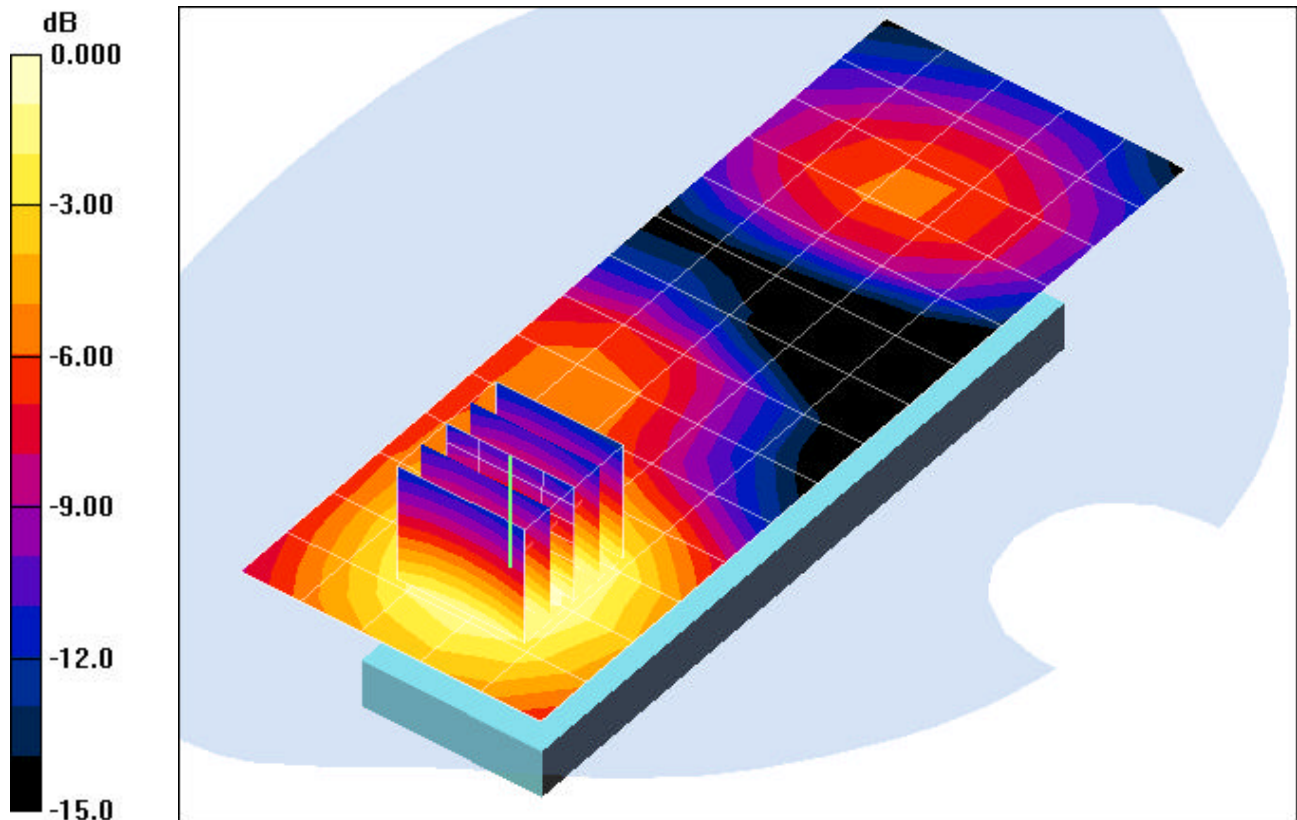

0 dB = 0.400mW/g

# PCTEST ENGINEERING LABORATORY, INC.

**DUT: SCP-PRO200 (Ver.I); Type: Cellular/PCS CDMA Phone with Bluetooth and EvDO  
Serial: A0000005FEE3A8**

Communication System: PCS CDMA; Frequency: 1880 MHz; Duty Cycle: 1:1

Medium: 1900 Brain ( $\sigma = 1.33$  mho/m,  $\epsilon_r = 41.83$ ,  $\rho = 1000$  kg/m<sup>3</sup>)

Phantom section: Flat Section; Space: 2.5 cm

Test Date: 09-11-2007; Ambient Temp: 23.3°C; Tissue Temp: 21.6°C

Probe: EX3DV4 - SN3561; ConvF(6.99, 6.99, 6.99); Calibrated: 11/23/2006

Sensor-Surface: 3mm (Mechanical Surface Detection)

Electronics: DAE4 Sn649; Calibrated: 1/23/2007

Phantom: SAM Sub; Type: SAM 4.0; Serial: TP-1357

Measurement SW: DASY4, V4.7 Build 53; Postprocessing SW: SEMCAD, V1.8 Build 172

**PCS Band, Face SAR, PTT Mode, Flip closed, Mid.ch, Standard Battery**

**Area Scan (6x10x1):** Measurement grid: dx=15mm, dy=15mm

**Zoom Scan (5x5x7)/Cube 0:** Measurement grid: dx=8mm, dy=8mm, dz=5mm

Reference Value = 10.2 V/m

Peak SAR (extrapolated) = 0.366 W/kg

**SAR(1 g) = 0.242 mW/g; SAR(10 g) = 0.157 mW/g**

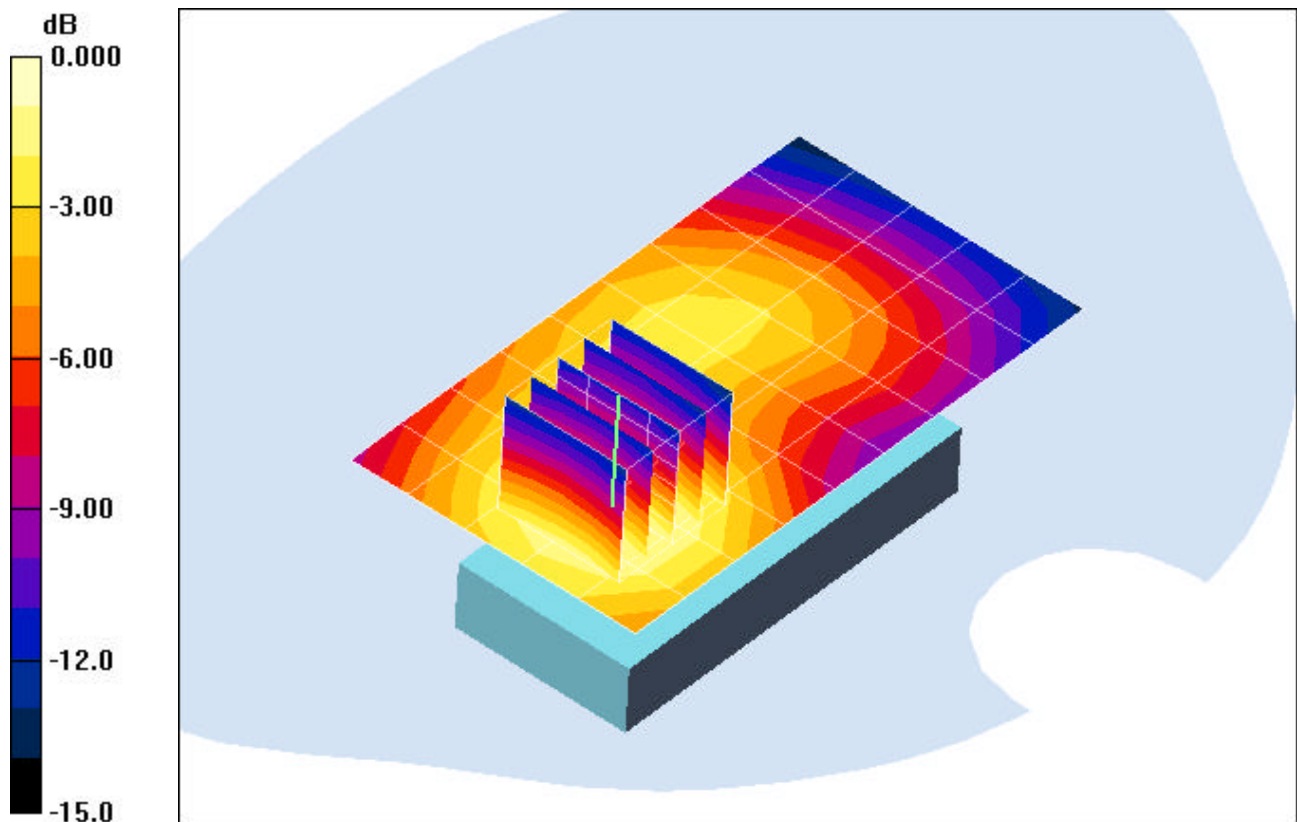

0 dB = 0.300mW/g

# PCTEST ENGINEERING LABORATORY, INC.

**DUT: SCP-PRO200 (Ver.I); Type: Cellular/PCS CDMA Phone with Bluetooth and EvDO  
Serial: A000005FEE3A8**

Communication System: Cellular CDMA; Frequency: 836.52 MHz; Duty Cycle: 1:1  
Medium: 835 Brain ( $\sigma = 0.93$  mho/m,  $\epsilon_r = 40.78$ ,  $\rho = 1000$  kg/m<sup>3</sup>)  
Phantom section: Left Section

Test Date: 09-11-2007; Ambient Temp: 23.3°C; Tissue Temp: 21.2°C

Probe: EX3DV4 - SN3561; ConvF(7.94, 7.94, 7.94); Calibrated: 11/23/2006  
Sensor-Surface: 3mm (Mechanical Surface Detection)  
Electronics: DAE4 Sn649; Calibrated: 1/23/2007  
Phantom: SAM Main; Type: SAM 4.0; Serial: TP-1114  
Measurement SW: DASY4, V4.7 Build 53; Postprocessing SW: SEMCAD, V1.8 Build 172

## Cellular Band, Left Head, Touch, Mid.ch, Standard Battery

**Area Scan (6x15x1):** Measurement grid: dx=15mm, dy=15mm  
**Zoom Scan (5x5x7)/Cube 0:** Measurement grid: dx=8mm, dy=8mm, dz=5mm  
Reference Value = 3.01 V/m  
Peak SAR (extrapolated) = 0.533 W/kg  
**SAR(1 g) = 0.405 mW/g; SAR(10 g) = 0.289 mW/g**

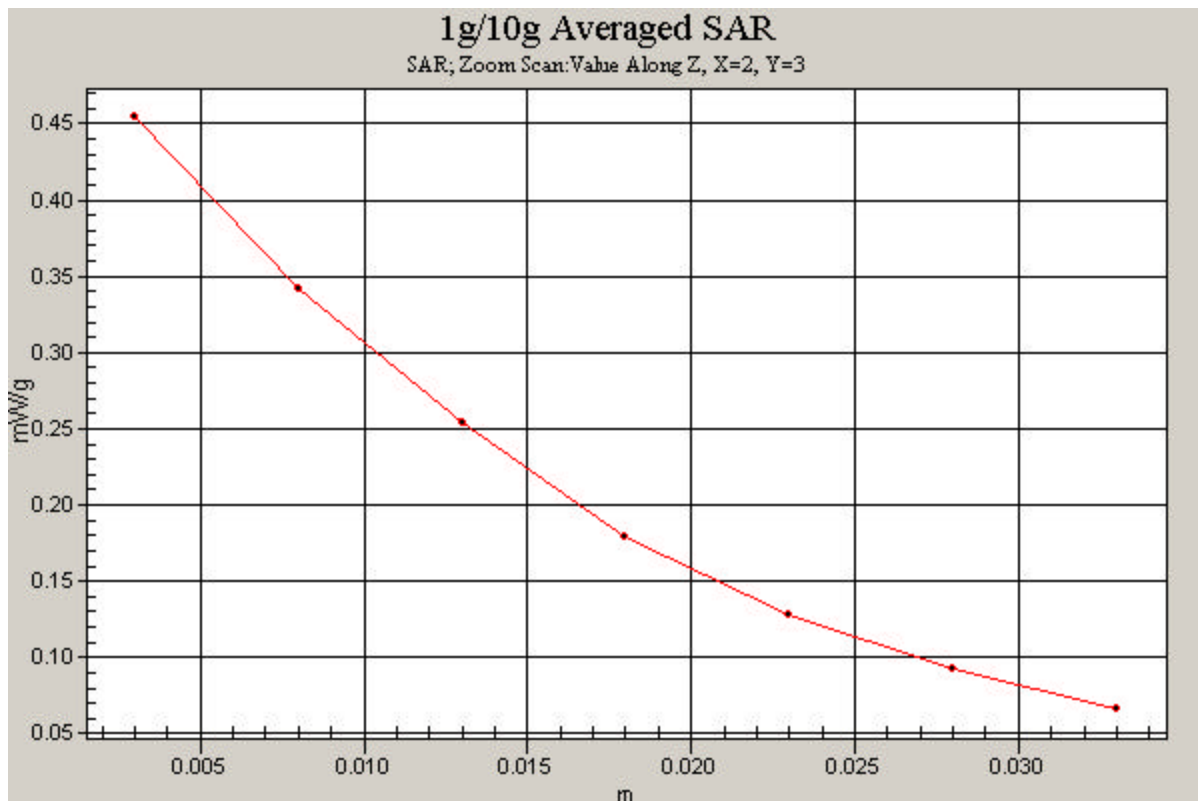

# PCTEST ENGINEERING LABORATORY, INC.

**DUT: SCP-PRO200 (Ver.I); Type: Cellular/PCS CDMA Phone with Bluetooth and EvDO  
Serial: A000005FEE3A8**

Communication System: PCS CDMA; Frequency: 1908.75 MHz; Duty Cycle: 1:1  
Medium: 1900 Brain ( $\sigma = 1.33$  mho/m,  $\epsilon_r = 41.83$ ,  $\rho = 1000$  kg/m<sup>3</sup>)  
Phantom section: Left Section

Test Date: 09-10-2007; Ambient Temp: 23.5°C; Tissue Temp: 21.5°C

Probe: EX3DV4 - SN3561; ConvF(6.99, 6.99, 6.99); Calibrated: 11/23/2006  
Sensor-Surface: 3mm (Mechanical Surface Detection)  
Electronics: DAE4 Sn649; Calibrated: 1/23/2007  
Phantom: SAM Sub; Type: SAM 4.0; Serial: TP-1357  
Measurement SW: DASY4, V4.7 Build 53; Postprocessing SW: SEMCAD, V1.8 Build 172

## PCS Band, Left Head, Touch, High.ch, Standard Battery

**Area Scan (6x15x1):** Measurement grid: dx=15mm, dy=15mm  
**Zoom Scan (5x5x7)/Cube 0:** Measurement grid: dx=8mm, dy=8mm, dz=5mm  
Reference Value = 8.09 V/m  
Peak SAR (extrapolated) = 2.00 W/kg  
**SAR(1 g) = 1.21 mW/g; SAR(10 g) = 0.671 mW/g**

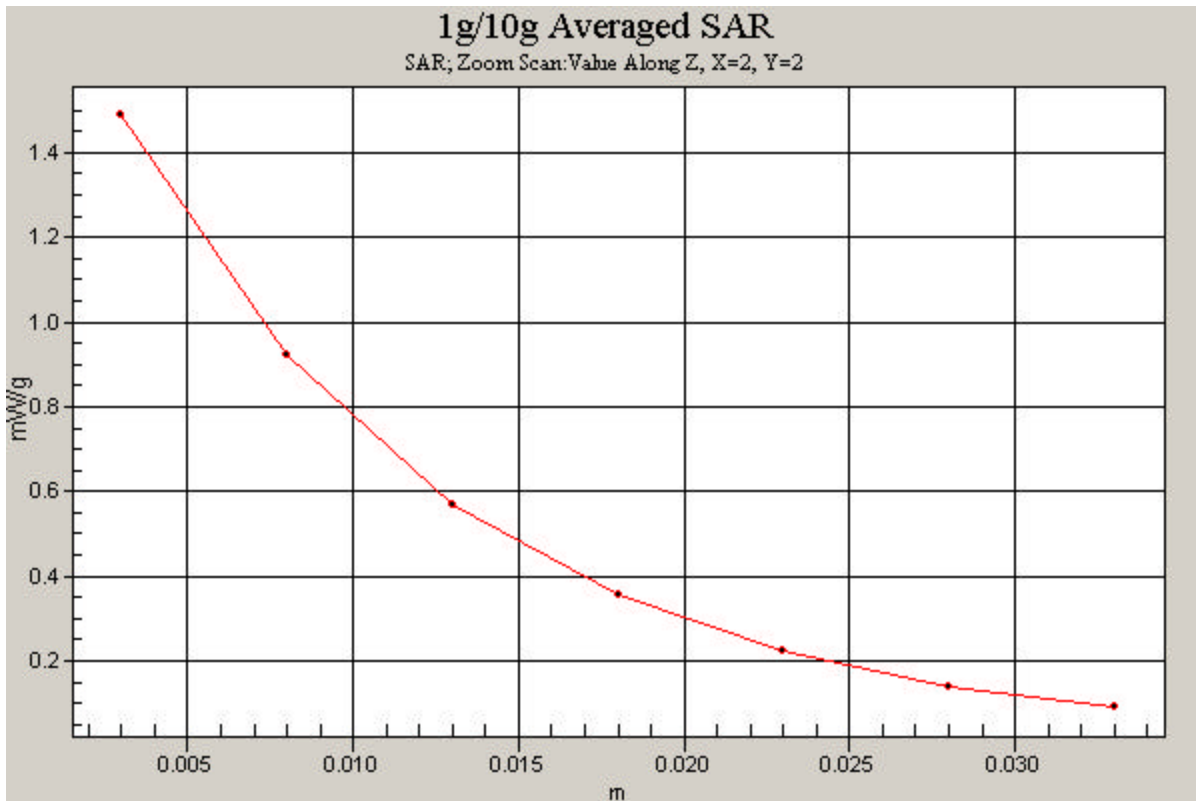

# PCTEST ENGINEERING LABORATORY, INC.

**DUT: SCP-PRO200 (Ver.I); Type: Cellular/PCS CDMA Phone with Bluetooth and EvDO  
Serial: A000005FEE3A8**

Communication System: Cellular CDMA; Frequency: 836.52 MHz; Duty Cycle: 1:1  
Medium: 835 Muscle ( $\sigma = 1.00$  mho/m,  $\epsilon_r = 52.50$ ,  $\rho = 1000$  kg/m<sup>3</sup>)  
Phantom section: Flat Section; Tested with Holster

Test Date: 09-11-2007; Ambient Temp: 23.6°C; Tissue Temp: 21.4°C

Probe: EX3DV4 - SN3561; ConvF(7.92, 7.92, 7.92); Calibrated: 11/23/2006  
Sensor-Surface: 3mm (Mechanical Surface Detection)  
Electronics: DAE4 Sn649; Calibrated: 1/23/2007  
Phantom: SAM Main; Type: SAM 4.0; Serial: TP-1114  
Measurement SW: DASY4, V4.7 Build 53; Postprocessing SW: SEMCAD, V1.8 Build 172

## Cellular Band, Body SAR, Front side, Mid.ch, Standard Battery

**Area Scan (6x10x1):** Measurement grid: dx=15mm, dy=15mm  
**Zoom Scan (5x5x7)/Cube 0:** Measurement grid: dx=8mm, dy=8mm, dz=5mm  
Reference Value = 14.6 V/m  
Peak SAR (extrapolated) = 0.277 W/kg  
**SAR(1 g) = 0.218 mW/g; SAR(10 g) = 0.161 mW/g**

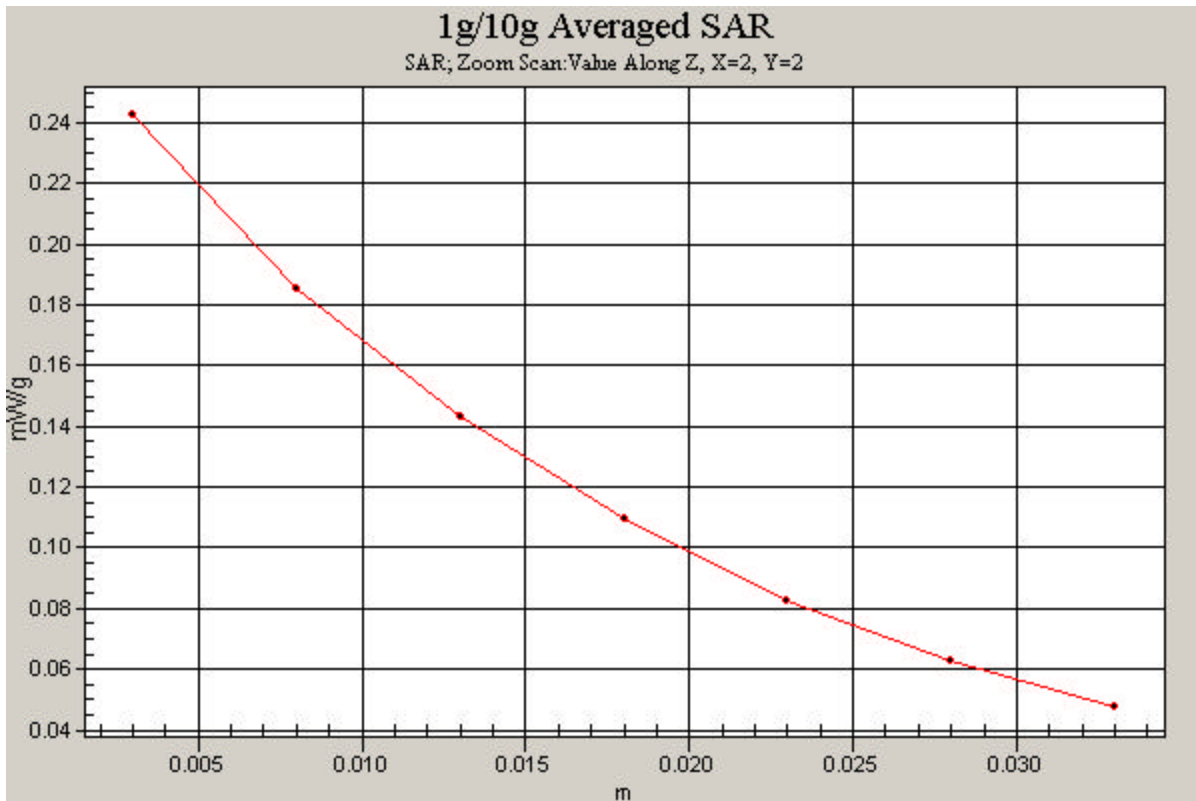



# PCTEST ENGINEERING LABORATORY, INC.

**DUT: SCP-PRO200 (Ver.I); Type: Cellular/PCS CDMA Phone with Bluetooth and EvDO  
Serial: A000005FEE3A8**

Communication System: PCS CDMA; Frequency: 1880 MHz; Duty Cycle: 1:1  
Medium: 1900 Muscle ( $\sigma = 1.58$  mho/m,  $\epsilon_r = 55.96$ ,  $\rho = 1000$  kg/m<sup>3</sup>)  
Phantom section: Flat Section; Tested with Holster

Test Date: 09-11-2007; Ambient Temp: 23.8°C; Tissue Temp: 21.7°C

Probe: EX3DV4 - SN3561; ConvF(6.47, 6.47, 6.47); Calibrated: 11/23/2006  
Sensor-Surface: 3mm (Mechanical Surface Detection)  
Electronics: DAE4 Sn649; Calibrated: 1/23/2007  
Phantom: SAM Sub; Type: SAM 4.0; Serial: TP-1357

Measurement SW: DASY4, V4.7 Build 53; Postprocessing SW: SEMCAD, V1.8 Build 172

## PCS Band, Body SAR, Front side, Mid.ch, Standard Battery

**Area Scan (6x10x1):** Measurement grid: dx=15mm, dy=15mm

**Zoom Scan (5x5x7)/Cube 0:** Measurement grid: dx=8mm, dy=8mm, dz=5mm

Reference Value = 14.1 V/m

Peak SAR (extrapolated) = 0.843 W/kg

**SAR(1 g) = 0.544 mW/g; SAR(10 g) = 0.335 mW/g**

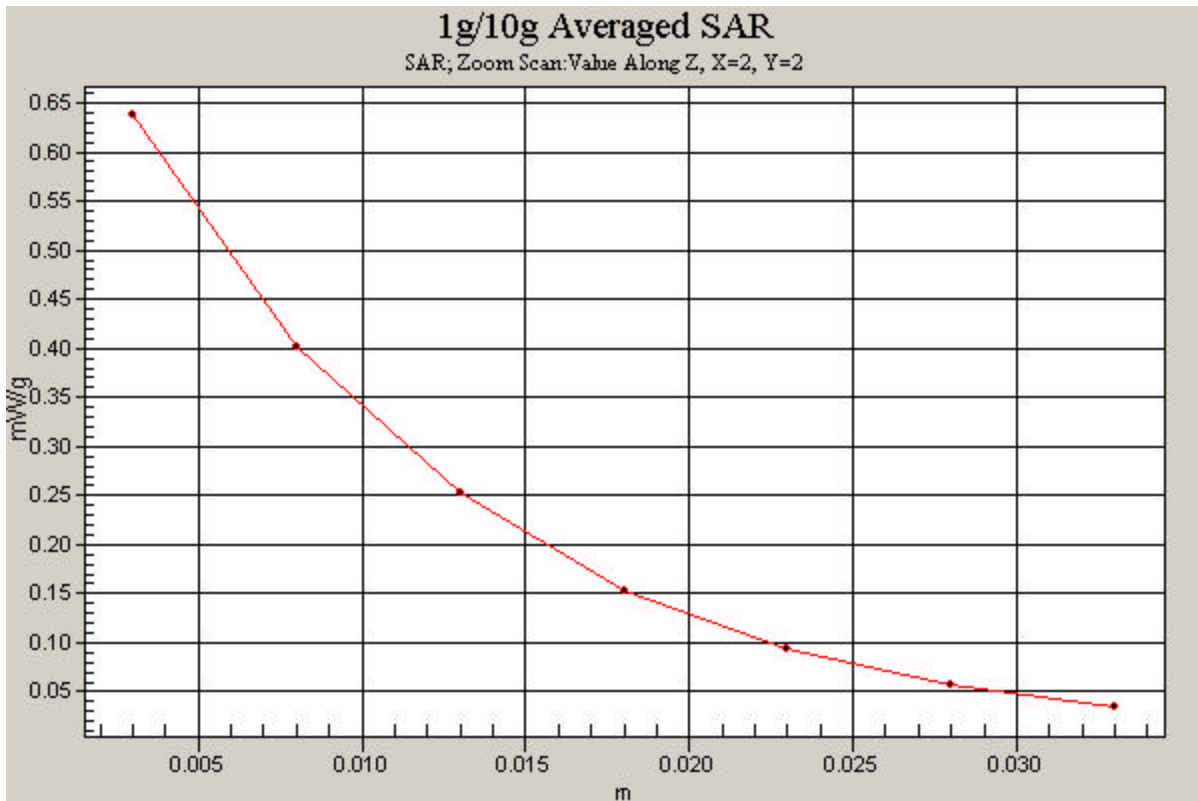

## **APPENDIX B: DIPOLE VALIDATION**

# PCTEST ENGINEERING LABORATORY, INC.

**DUT: D835V2 - SN4d047; Type: 835MHz SAR Validation Dipole ; Serial: 4d047**

Communication System: CW; Frequency: 835 MHz; Duty Cycle: 1:1

Medium: 835 Brain ( $\sigma = 0.93$  mho/m,  $\epsilon_r = 40.78$ ,  $\rho = 1000$  kg/m<sup>3</sup>)

Phantom section: Flat Section; Space: 1.5 cm

Test Date: 09-11-2007; Ambient Temp: 23.3°C; Tissue Temp: 21.2°C

Probe: EX3DV4 - SN3561; ConvF(7.94, 7.94, 7.94); Calibrated: 11/23/2006

Sensor-Surface: 3mm (Mechanical Surface Detection)

Electronics: DAE4 Sn649; Calibrated: 1/23/2007

Phantom: SAM Main; Type: SAM 4.0; Serial: TP-1114

Measurement SW: DASY4, V4.7 Build 53; Postprocessing SW: SEMCAD, V1.8 Build 172

## 835MHz Dipole Validation

**Area Scan (7x13x1):** Measurement grid: dx=15mm, dy=15mm

**Zoom Scan (5x5x7)/Cube 0:** Measurement grid: dx=8mm, dy=8mm, dz=5mm

Input Power = 24.0 dBm (250 mW)

**SAR(1 g) = 2.41 mW/g; SAR(10 g) = 1.59 mW/g**

Target SAR(1g) = 2.29 mW/g; Deviation = +5.24 %

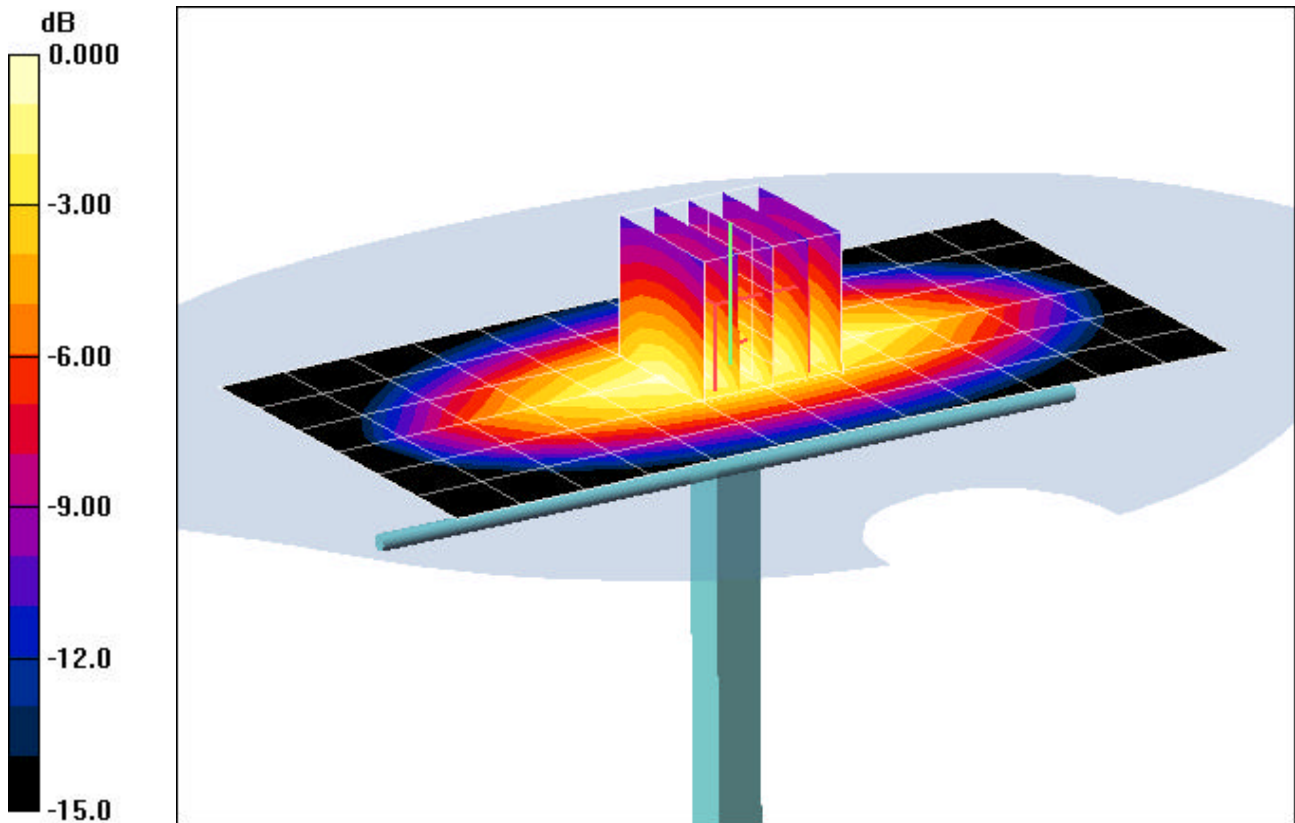

0 dB = 3.00mW/g

# PCTEST ENGINEERING LABORATORY, INC.

**DUT: D1900V2 - SN5d080; Type: 1900MHz SAR Validation Dipole; Serial: 5d080**

Communication System: CW; Frequency: 1900 MHz; Duty Cycle: 1:1

Medium: 1900 Brain ( $\sigma = 1.33$  mho/m,  $\epsilon_r = 41.83$ ,  $\rho = 1000$  kg/m<sup>3</sup>)

Phantom section: Flat Section; Space: 1.0 cm

Test Date: 09-10-2007; Ambient Temp: 23.5°C; Tissue Temp: 21.5°C

Probe: EX3DV4 - SN3561; ConvF(6.99, 6.99, 6.99); Calibrated: 11/23/2006

Sensor-Surface: 3mm (Mechanical Surface Detection)

Electronics: DAE4 Sn649; Calibrated: 1/23/2007

Phantom: SAM Sub; Type: SAM 4.0; Serial: TP-1357

Measurement SW: DASY4, V4.7 Build 53; Postprocessing SW: SEMCAD, V1.8 Build 172

## 1900MHz Dipole Validation

**Area Scan (5x7x1):** Measurement grid: dx=15mm, dy=15mm

**Zoom Scan (5x5x7)/Cube 0:** Measurement grid: dx=8mm, dy=8mm, dz=5mm

Input Power = 20.0 dBm (100 mW)

**SAR(1 g) = 3.75 mW/g; SAR(10 g) = 1.93 mW/g**

Target SAR(1g) = 3.77 mW/g; Deviation = -0.53 %

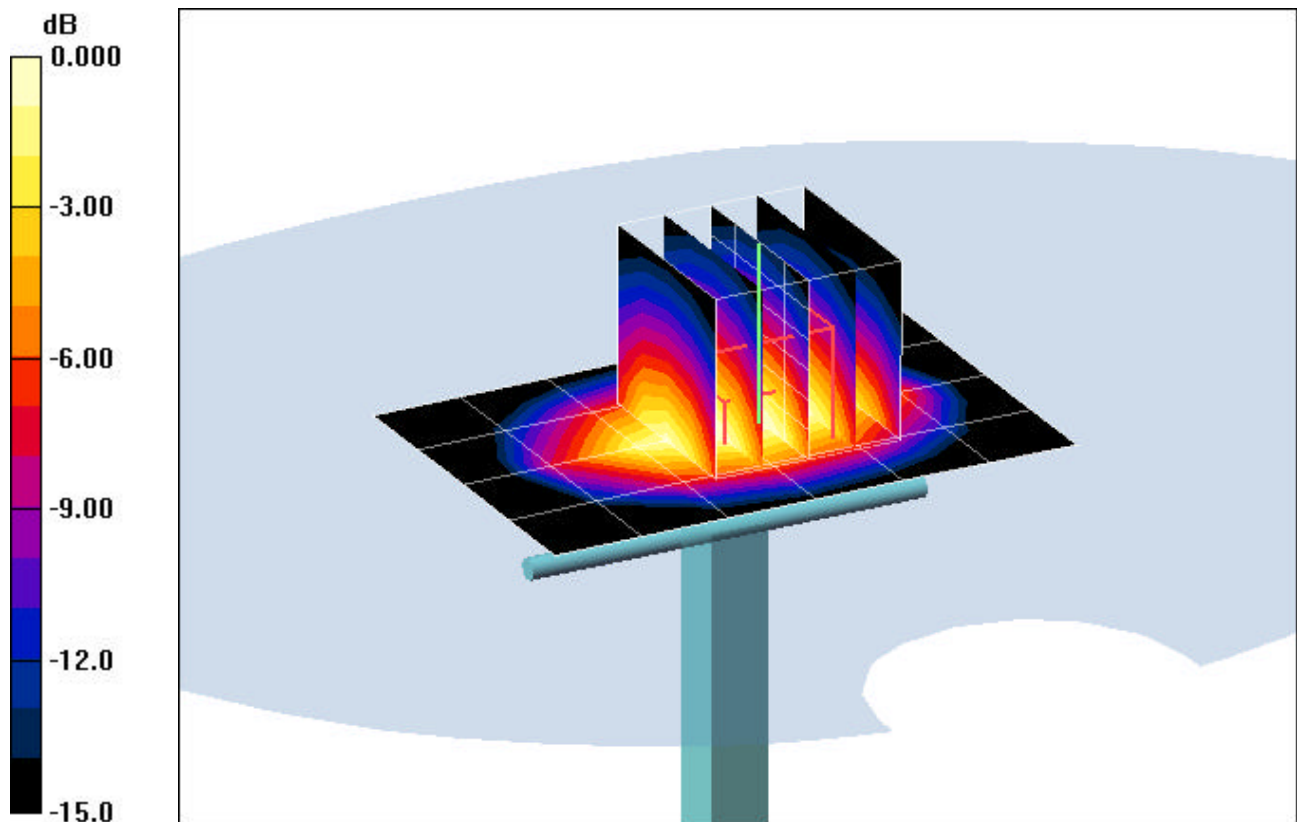

0 dB = 4.00mW/g

# PCTEST ENGINEERING LABORATORY, INC.

**DUT: D1900V2 - SN5d080; Type: 1900MHz SAR Validation Dipole; Serial: 5d080**

Communication System: CW; Frequency: 1900 MHz; Duty Cycle: 1:1

Medium: 1900 Brain ( $\sigma = 1.33$  mho/m,  $\epsilon_r = 41.83$ ,  $\rho = 1000$  kg/m<sup>3</sup>)

Phantom section: Flat Section; Space: 1.0 cm

Test Date: 09-11-2007; Ambient Temp: 23.3°C; Tissue Temp: 21.6°C

Probe: EX3DV4 - SN3561; ConvF(6.99, 6.99, 6.99); Calibrated: 11/23/2006

Sensor-Surface: 3mm (Mechanical Surface Detection)

Electronics: DAE4 Sn649; Calibrated: 1/23/2007

Phantom: SAM Sub; Type: SAM 4.0; Serial: TP-1357

Measurement SW: DASY4, V4.7 Build 53; Postprocessing SW: SEMCAD, V1.8 Build 172

## 1900MHz Dipole Validation

**Area Scan (5x7x1):** Measurement grid: dx=15mm, dy=15mm

**Zoom Scan (5x5x7)/Cube 0:** Measurement grid: dx=8mm, dy=8mm, dz=5mm

Input Power = 20.0 dBm (100 mW)

**SAR(1 g) = 3.83 mW/g; SAR(10 g) = 1.97 mW/g**

Target SAR(1g) = 3.77 mW/g; Deviation = +1.59 %

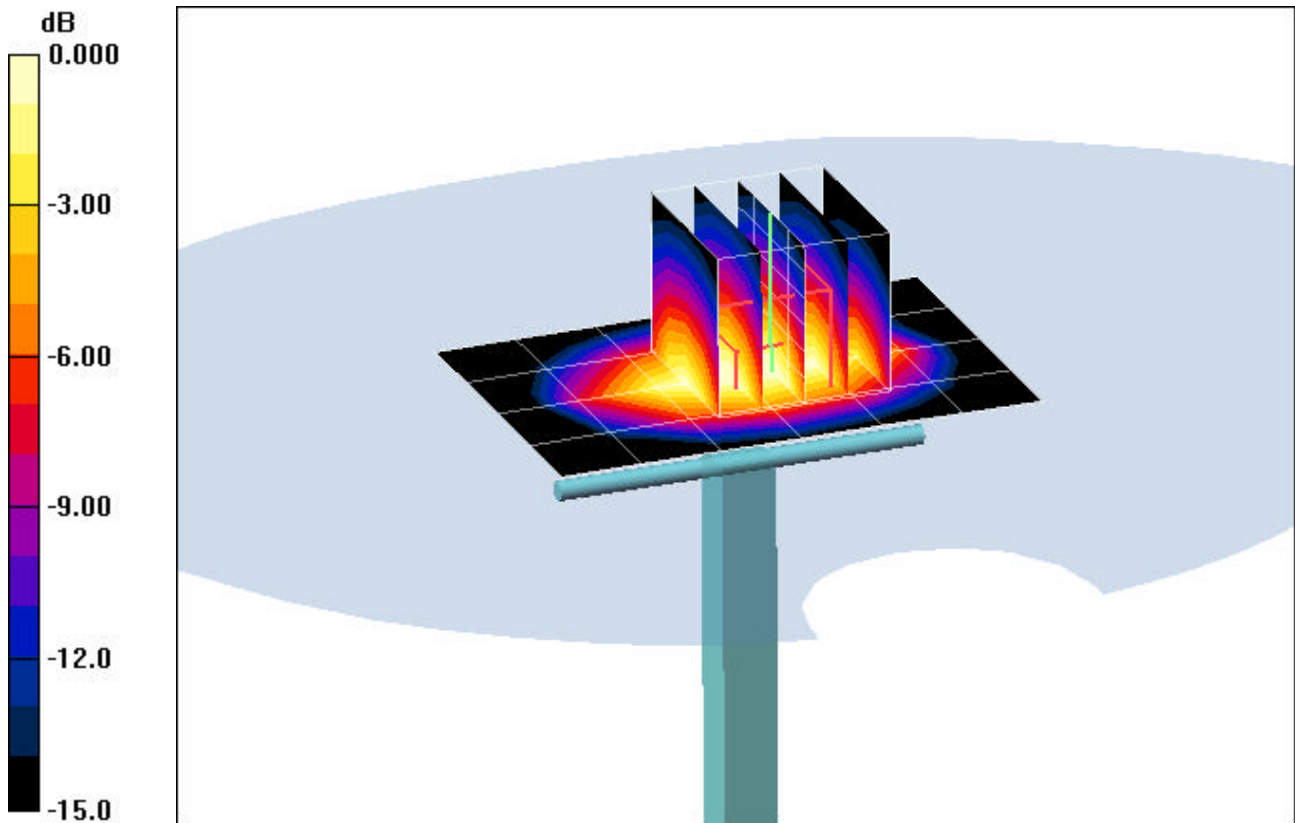

0 dB = 4.00mW/g

## **APPENDIX C: PROBE CALIBRATION**



Accredited by the Swiss Federal Office of Metrology and Accreditation  
The Swiss Accreditation Service is one of the signatories to the EA  
Multilateral Agreement for the recognition of calibration certificates

Accreditation No.: **SCS 108**

Client **PC Test**

Certificate No: **EX3-3561\_Nov06**

## CALIBRATION CERTIFICATE

Object: **EX3DV4 - SN:3561**

Calibration procedure(s): **QA CAL-01.v5 and QA CAL-14.v3  
Calibration procedure for dosimetric E-field probes**

Calibration date: **November 23, 2006**

Condition of the calibrated item: **In Tolerance**

This calibration certificate documents the traceability to national standards, which realize the physical units of measurements (SI).  
The measurements and the uncertainties with confidence probability are given on the following pages and are part of the certificate.

All calibrations have been conducted in the closed laboratory facility: environment temperature (22 ± 3)°C and humidity < 70%.

Calibration Equipment used (M&TE critical for calibration)

Primary Standards	ID #	Cal Date (Calibrated by, Certificate No.)	Scheduled Calibration
Power meter E4419B	GB41293874	5-Apr-06 (METAS, No. 251-00557)	Apr-07
Power sensor E4412A	MY41495277	5-Apr-06 (METAS, No. 251-00557)	Apr-07
Power sensor E4412A	MY41498087	5-Apr-06 (METAS, No. 251-00557)	Apr-07
Reference 3 dB Attenuator	SN: S5054 (3c)	10-Aug-06 (METAS, No. 217-00592)	Aug-07
Reference 20 dB Attenuator	SN: S5086 (20b)	4-Apr-06 (METAS, No. 251-00558)	Apr-07
Reference 30 dB Attenuator	SN: S5129 (30b)	10-Aug-06 (METAS, No. 217-00593)	Aug-07
Reference Probe ES3DV2	SN: 3013	2-Jan-06 (SPEAG, No. ES3-3013_Jan06)	Jan-07
DAE4	SN: 654	21-Jun-06 (SPEAG, No. DAE4-654_Jun06)	Jun-07

Secondary Standards	ID #	Check Date (in house)	Scheduled Check
RF generator HP 8648C	US3642U01700	4-Aug-99 (SPEAG, in house check Nov-05)	In house check: Nov-07
Network Analyzer HP 8753E	US37390585	18-Oct-01 (SPEAG, in house check Oct-06)	In house check: Oct-07

	Name	Function	Signature
Calibrated by:	Katja Pokovic	Technical Manager	
Approved by:	Niels Kuster	Quality Manager	

Issued: November 23, 2006

This calibration certificate shall not be reproduced except in full without written approval of the laboratory.



Accredited by the Swiss Federal Office of Metrology and Accreditation  
The Swiss Accreditation Service is one of the signatories to the EA  
Multilateral Agreement for the recognition of calibration certificates

Accreditation No.: **SCS 108**

### Glossary:

TSL	tissue simulating liquid
NORM <sub>x,y,z</sub>	sensitivity in free space
ConF	sensitivity in TSL / NORM <sub>x,y,z</sub>
DCP	diode compression point
Polarization $\varphi$	$\varphi$ rotation around probe axis
Polarization $\vartheta$	$\vartheta$ rotation around an axis that is in the plane normal to probe axis (at measurement center), i.e., $\vartheta = 0$ is normal to probe axis

### Calibration is Performed According to the Following Standards:

- IEEE Std 1528-2003, "IEEE Recommended Practice for Determining the Peak Spatial-Averaged Specific Absorption Rate (SAR) in the Human Head from Wireless Communications Devices: Measurement Techniques", December 2003
- CENELEC EN 50361, "Basic standard for the measurement of Specific Absorption Rate related to human exposure to electromagnetic fields from mobile phones (300 MHz - 3 GHz), July 2001

### Methods Applied and Interpretation of Parameters:

- NORM<sub>x,y,z</sub>**: Assessed for E-field polarization  $\vartheta = 0$  ( $f \leq 900$  MHz in TEM-cell;  $f > 1800$  MHz: R22 waveguide). NORM<sub>x,y,z</sub> are only intermediate values, i.e., the uncertainties of NORM<sub>x,y,z</sub> does not effect the E<sup>2</sup>-field uncertainty inside TSL (see below *ConvF*).
- NORM(f)<sub>x,y,z</sub>** = NORM<sub>x,y,z</sub> \* *frequency\_response* (see Frequency Response Chart). This linearization is implemented in DASY4 software versions later than 4.2. The uncertainty of the frequency response is included in the stated uncertainty of *ConvF*.
- DCP<sub>x,y,z</sub>**: DCP are numerical linearization parameters assessed based on the data of power sweep (no uncertainty required). DCP does not depend on frequency nor media.
- ConvF and Boundary Effect Parameters**: Assessed in flat phantom using E-field (or Temperature Transfer Standard for  $f \leq 800$  MHz) and inside waveguide using analytical field distributions based on power measurements for  $f > 800$  MHz. The same setups are used for assessment of the parameters applied for boundary compensation (alpha, depth) of which typical uncertainty values are given. These parameters are used in DASY4 software to improve probe accuracy close to the boundary. The sensitivity in TSL corresponds to NORM<sub>x,y,z</sub> \* *ConvF* whereby the uncertainty corresponds to that given for *ConvF*. A frequency dependent *ConvF* is used in DASY version 4.4 and higher which allows extending the validity from  $\pm 50$  MHz to  $\pm 100$  MHz.
- Spherical isotropy (3D deviation from isotropy)**: in a field of low gradients realized using a flat phantom exposed by a patch antenna.
- Sensor Offset**: The sensor offset corresponds to the offset of virtual measurement center from the probe tip (on probe axis). No tolerance required.



# Probe EX3DV4

## SN:3561

Manufactured:	February 14, 2005
Last calibrated:	August 24, 2005
Recalibrated:	November 23, 2006

Calibrated for DASYS Systems

(Note: non-compatible with DASYS2 system!)

## DASY - Parameters of Probe: EX3DV4 SN:3561

### Sensitivity in Free Space<sup>A</sup>

NormX	<b>0.450</b> ± 10.1%	$\mu\text{V}/(\text{V}/\text{m})^2$
NormY	<b>0.490</b> ± 10.1%	$\mu\text{V}/(\text{V}/\text{m})^2$
NormZ	<b>0.420</b> ± 10.1%	$\mu\text{V}/(\text{V}/\text{m})^2$

### Diode Compression<sup>B</sup>

DCP X	<b>87</b> mV
DCP Y	<b>91</b> mV
DCP Z	<b>89</b> mV

### Sensitivity in Tissue Simulating Liquid (Conversion Factors)

Please see Page 8.

### Boundary Effect

**TSL**                      **900 MHz**      **Typical SAR gradient: 5 % per mm**

Sensor Center to Phantom Surface Distance		<b>2.0 mm</b>	<b>3.0 mm</b>
SAR <sub>be</sub> [%]	Without Correction Algorithm	3.8	1.5
SAR <sub>be</sub> [%]	With Correction Algorithm	0.0	0.0

**TSL**                      **1810 MHz**      **Typical SAR gradient: 10 % per mm**

Sensor Center to Phantom Surface Distance		<b>2.0 mm</b>	<b>3.0 mm</b>
SAR <sub>be</sub> [%]	Without Correction Algorithm	4.7	2.8
SAR <sub>be</sub> [%]	With Correction Algorithm	1.1	0.8

### Sensor Offset

Probe Tip to Sensor Center                      **1.0 mm**

**The reported uncertainty of measurement is stated as the standard uncertainty of measurement multiplied by the coverage factor k=2, which for a normal distribution corresponds to a coverage probability of approximately 95%.**

<sup>A</sup> The uncertainties of NormX,Y,Z do not affect the E<sup>2</sup>-field uncertainty inside TSL (see Page 8).

<sup>B</sup> Numerical linearization parameter: uncertainty not required.

# Frequency Response of E-Field

(TEM-Cell:ifi1110 EXX, Waveguide: R22)

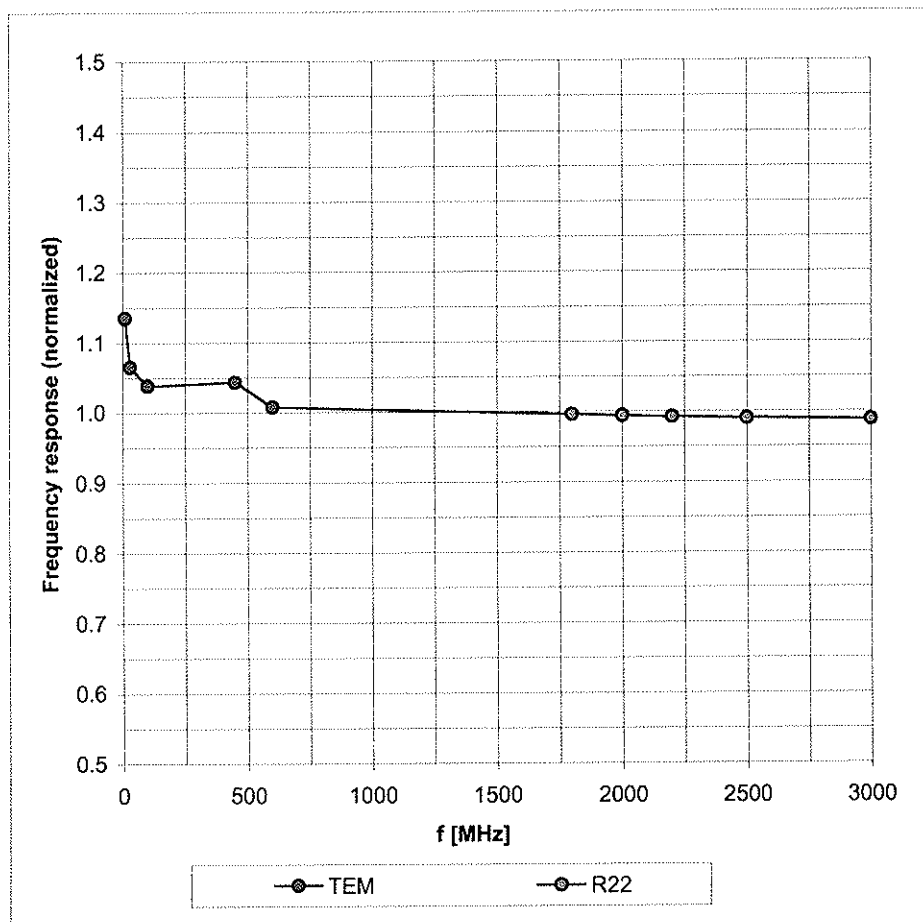

Uncertainty of Frequency Response of E-field:  $\pm 6.3\%$  ( $k=2$ )

### Receiving Pattern ( $\phi$ ), $\vartheta = 0^\circ$

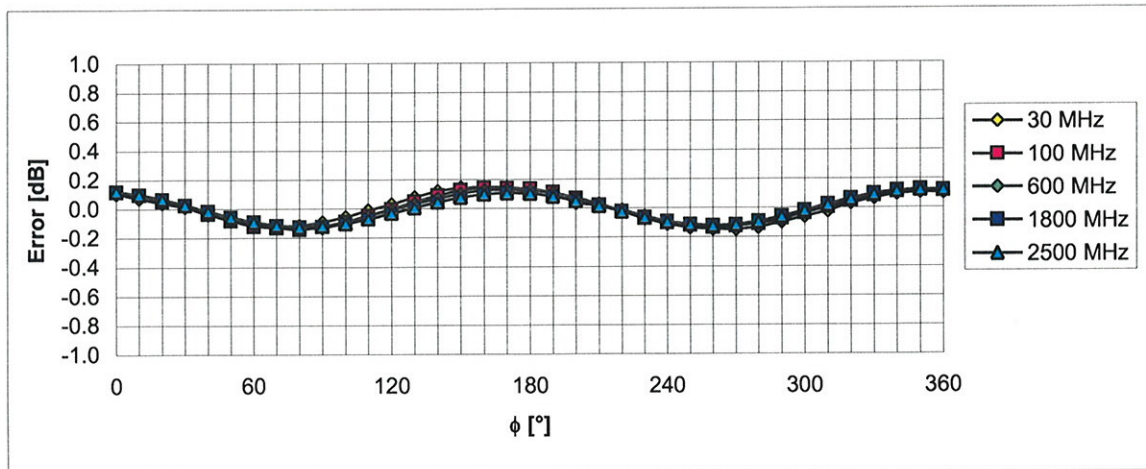
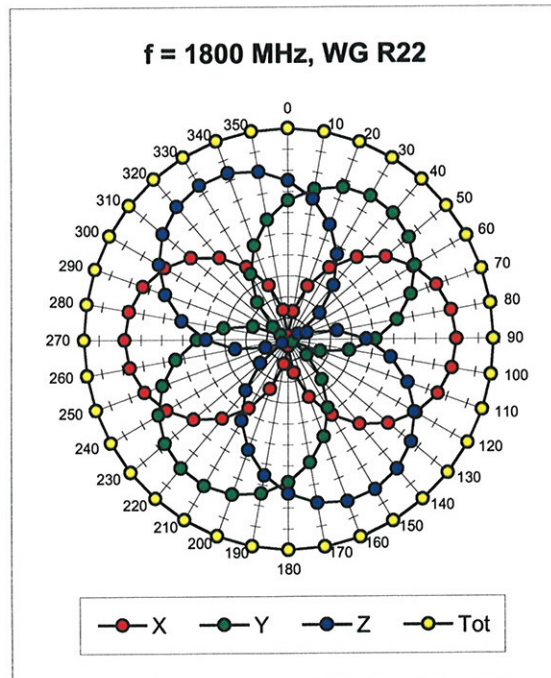
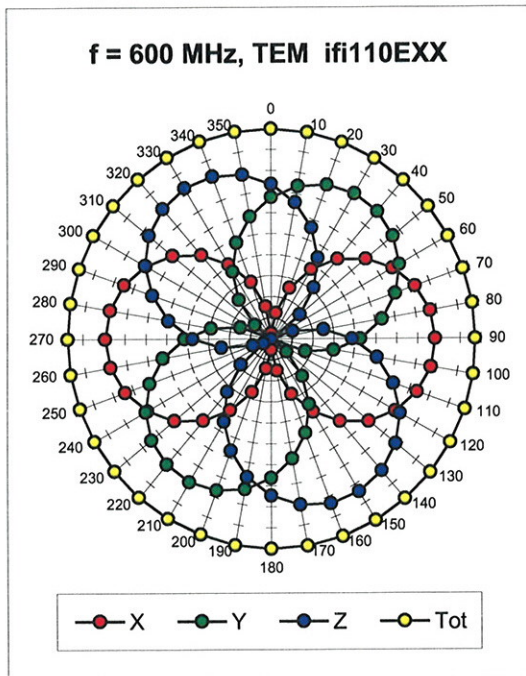

Uncertainty of Axial Isotropy Assessment:  $\pm 0.5\%$  ( $k=2$ )

## Dynamic Range $f(\text{SAR}_{\text{head}})$ (Waveguide R22, $f = 1800 \text{ MHz}$ )

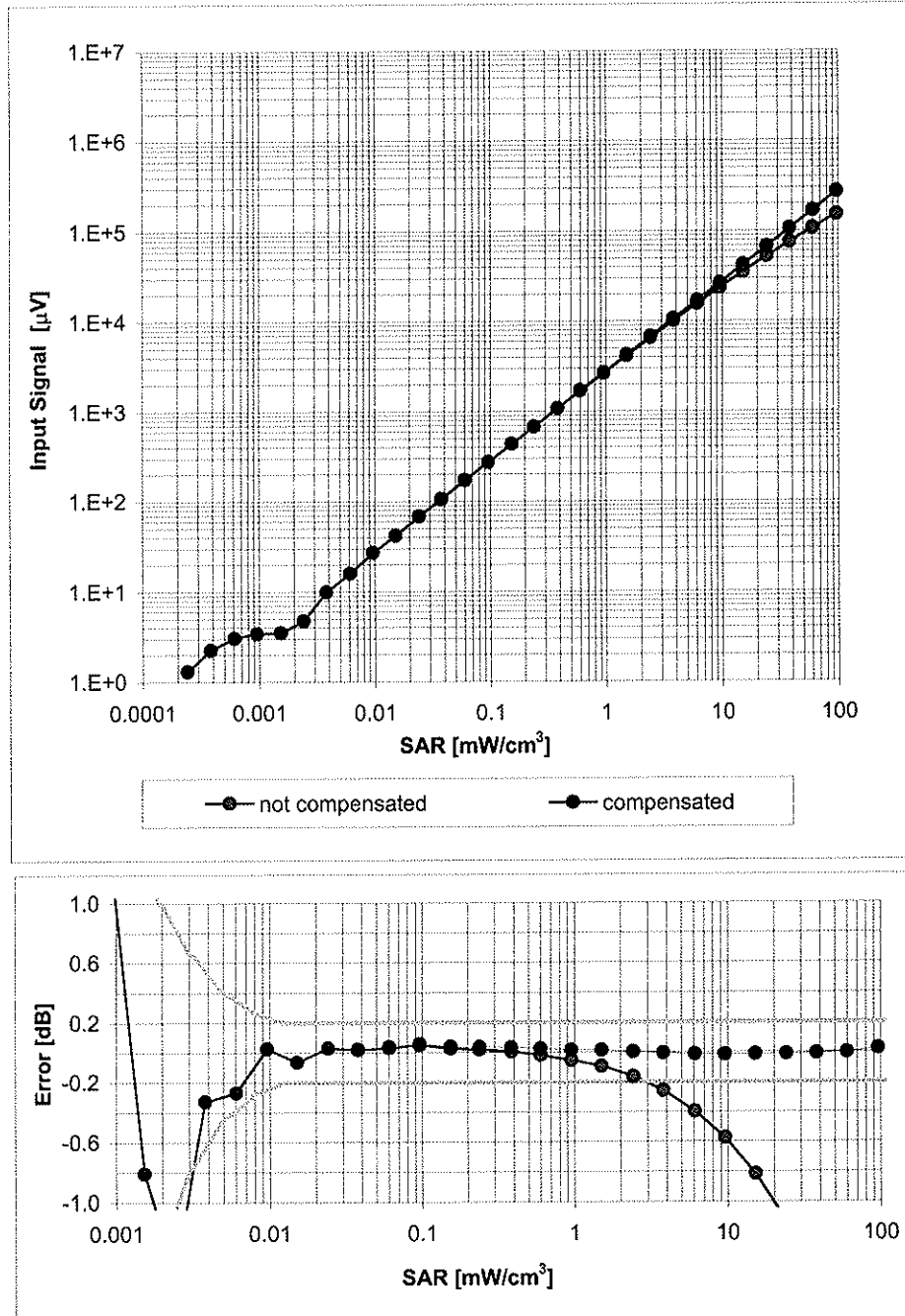

**Uncertainty of Linearity Assessment:  $\pm 0.6\%$  ( $k=2$ )**

## Conversion Factor Assessment

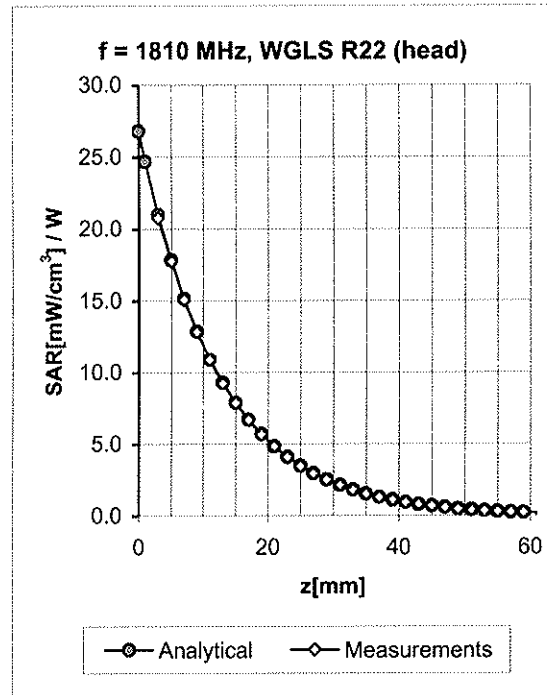
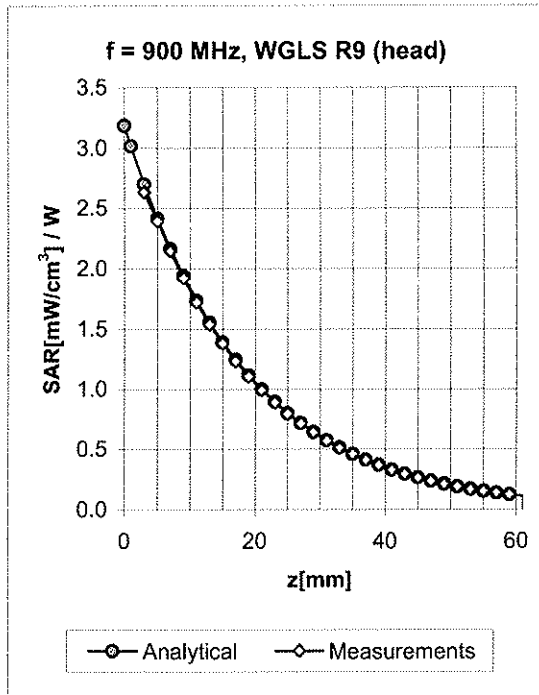

f [MHz]	Validity [MHz] <sup>c</sup>	TSL	Permittivity	Conductivity	Alpha	Depth	ConvF Uncertainty
900	± 50 / ± 100	Head	41.5 ± 5%	0.97 ± 5%	0.35	1.30	7.94 ± 11.0% (k=2)
1810	± 50 / ± 100	Head	40.0 ± 5%	1.40 ± 5%	0.19	1.20	6.99 ± 11.0% (k=2)
2450	± 50 / ± 100	Head	39.2 ± 5%	1.80 ± 5%	0.44	1.00	6.32 ± 11.8% (k=2)
5200	± 50 / ± 100	Head	36.0 ± 5%	4.66 ± 5%	0.45	1.36	4.34 ± 13.1% (k=2)
5300	± 50 / ± 100	Head	35.9 ± 5%	4.76 ± 5%	0.45	1.40	4.23 ± 13.1% (k=2)
5800	± 50 / ± 100	Head	35.3 ± 5%	5.27 ± 5%	0.45	1.42	4.01 ± 13.1% (k=2)
900	± 50 / ± 100	Body	55.0 ± 5%	1.05 ± 5%	0.40	1.25	7.92 ± 11.0% (k=2)
1810	± 50 / ± 100	Body	53.3 ± 5%	1.52 ± 5%	0.21	1.20	6.47 ± 11.0% (k=2)
2450	± 50 / ± 100	Body	52.7 ± 5%	1.95 ± 5%	0.47	1.00	6.33 ± 11.8% (k=2)
5200	± 50 / ± 100	Body	49.0 ± 5%	5.30 ± 5%	0.40	1.50	3.89 ± 13.1% (k=2)
5300	± 50 / ± 100	Body	48.5 ± 5%	5.42 ± 5%	0.45	1.50	3.63 ± 13.1% (k=2)
5800	± 50 / ± 100	Body	48.2 ± 5%	6.00 ± 5%	0.45	1.70	3.59 ± 13.1% (k=2)

<sup>c</sup> The validity of ± 100 MHz only applies for DASY v4.4 and higher (see Page 2). The uncertainty is the RSS of the ConvF uncertainty at calibration frequency and the uncertainty for the indicated frequency band.

# Deviation from Isotropy in HSL

Error ( $\phi, \vartheta$ ),  $f = 900$  MHz

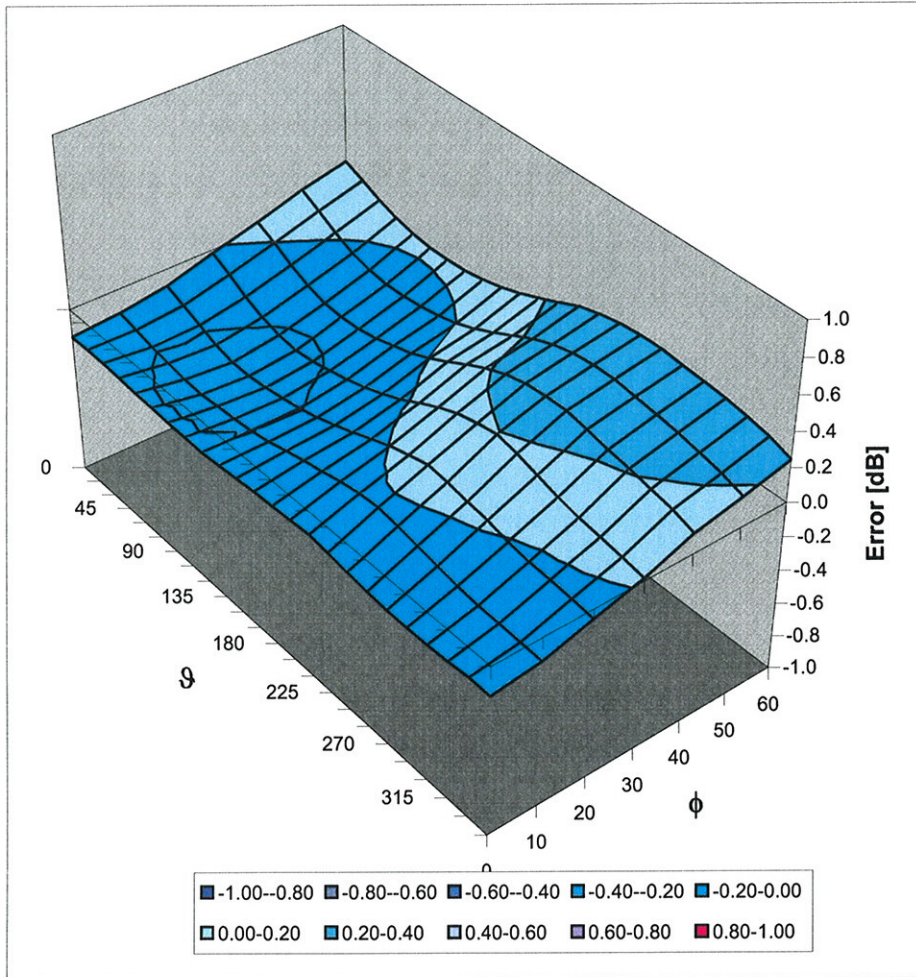

Uncertainty of Spherical Isotropy Assessment:  $\pm 2.6\%$  ( $k=2$ )