

## **APPENDIX A: SAR TEST DATA**

# PCTEST ENGINEERING LABORATORY, INC.

**DUT: SCP -7300; Type: SANYO Tri Mode Phone; Serial: FCC1**

Communication System: AMPS; Frequency: 836.49 MHz; Duty Cycle: 1:1

Medium: 835 Brain ( $\sigma = 0.9$  mho/m,  $\epsilon_r = 40.3$ ,  $\rho = 1000$  kg/m<sup>3</sup>)

Phantom section: Right Section

Test Date: 10-28-2003; Ambient Temp: 20.2°C; Tissue Temp: 18.2°C

Probe: ES3DV2 - SN3022; ConvF(6.1, 6.1, 6.1); Calibrated: 9/23/2003

Sensor-Surface: 4mm (Mechanical Surface Detection)

Electronics: DAE3 SN330; Calibrated: 12/1/2002

Phantom: SAM 12b; Type: SAM 4.0; Serial: TP:1197

Measurement SW: DASY4, V4.1 Build 47; Postprocessing SW: SEMCAD, V1.8 Build 62

## Ch.383, Touch, Ant Out, Standard Battery

**Area Scan (51x151x1):** Measurement grid: dx=15mm, dy=15mm

**Zoom Scan (7x7x7)/Cube 0:** Measurement grid: dx=5mm, dy=5mm, dz=5mm

Peak SAR (extrapolated) = 2.26 W/kg

SAR(1 g) = 1.32 mW/g; SAR(10 g) = 0.818 mW/g

Reference Value = 14.8 V/m

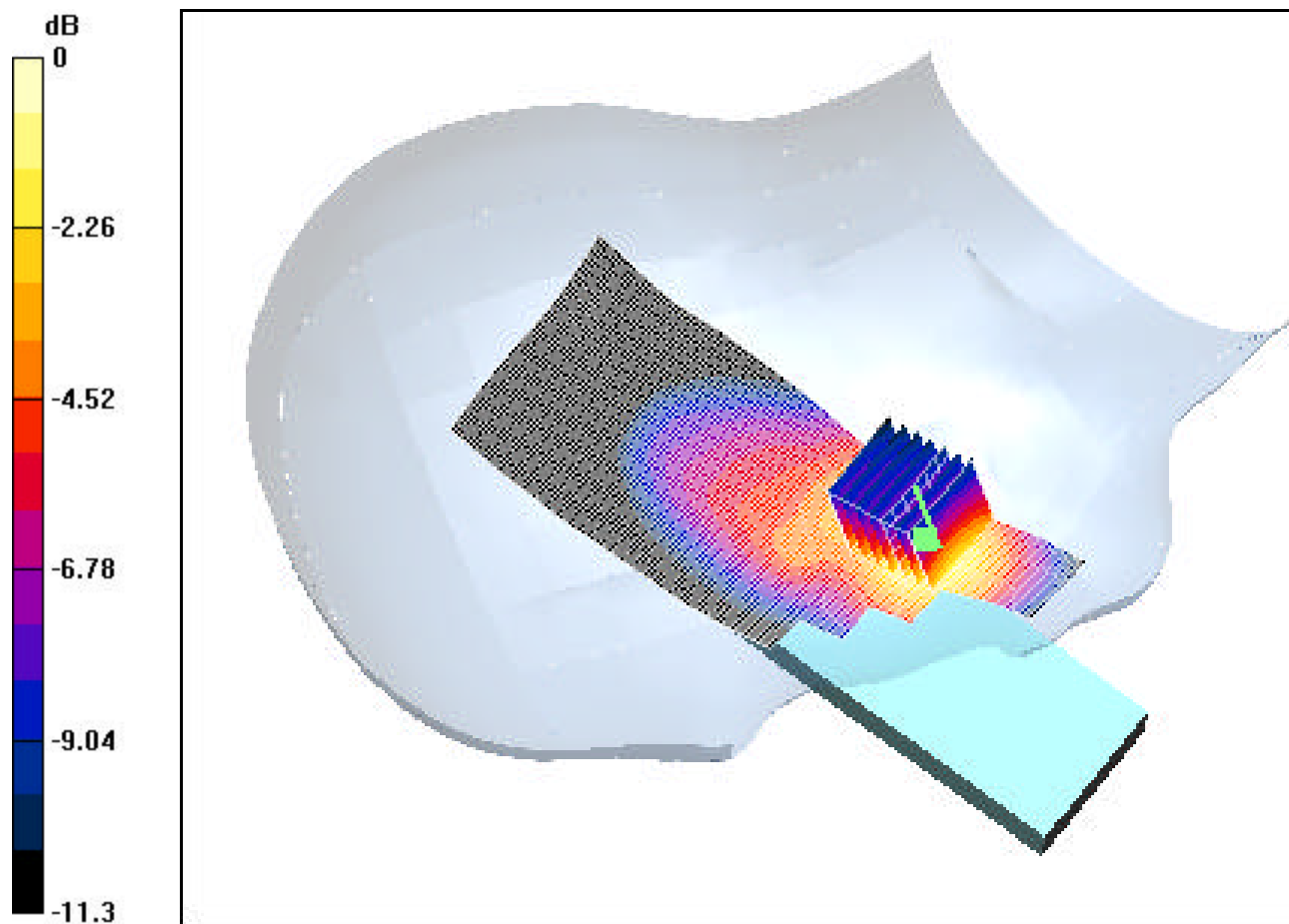

0 dB = 1.45mW/g

# PCTEST ENGINEERING LABORATORY, INC.

**DUT: SCP -7300; Type: SANYO Tri Mode Phone; Serial: FCC1**

Communication System: AMPS; Frequency: 836.49 MHz; Duty Cycle: 1:1

Medium: 835 Brain ( $\sigma = 0.9$  mho/m,  $\epsilon_r = 40.3$ ,  $\rho = 1000$  kg/m<sup>3</sup>)

Phantom section: Right Section

Test Date: 11-03-2003; Ambient Temp: 20.2°C; Tissue Temp: 19.2°C

Probe: ES3DV2 - SN3022; ConvF(6.1, 6.1, 6.1); Calibrated: 9/23/2003

Sensor-Surface: 4mm (Mechanical Surface Detection)

Electronics: DAE3 SN330; Calibrated: 12/1/2002

Phantom: SAM 12b; Type: SAM 4.0; Serial: TP:1197

Measurement SW: DASY4, V4.1 Build 47; Postprocessing SW: SEMCAD, V1.8 Build 62

## Ch.383, Tilt, Ant In, Standard Battery

**Area Scan (51x141x1):** Measurement grid: dx=15mm, dy=15mm

**Zoom Scan (7x7x7)/Cube 0:** Measurement grid: dx=5mm, dy=5mm, dz=5mm

Peak SAR (extrapolated) = 0.255 W/kg

SAR(1 g) = 0.197 mW/g; SAR(10 g) = 0.146 mW/g

Reference Value = 13 V/m

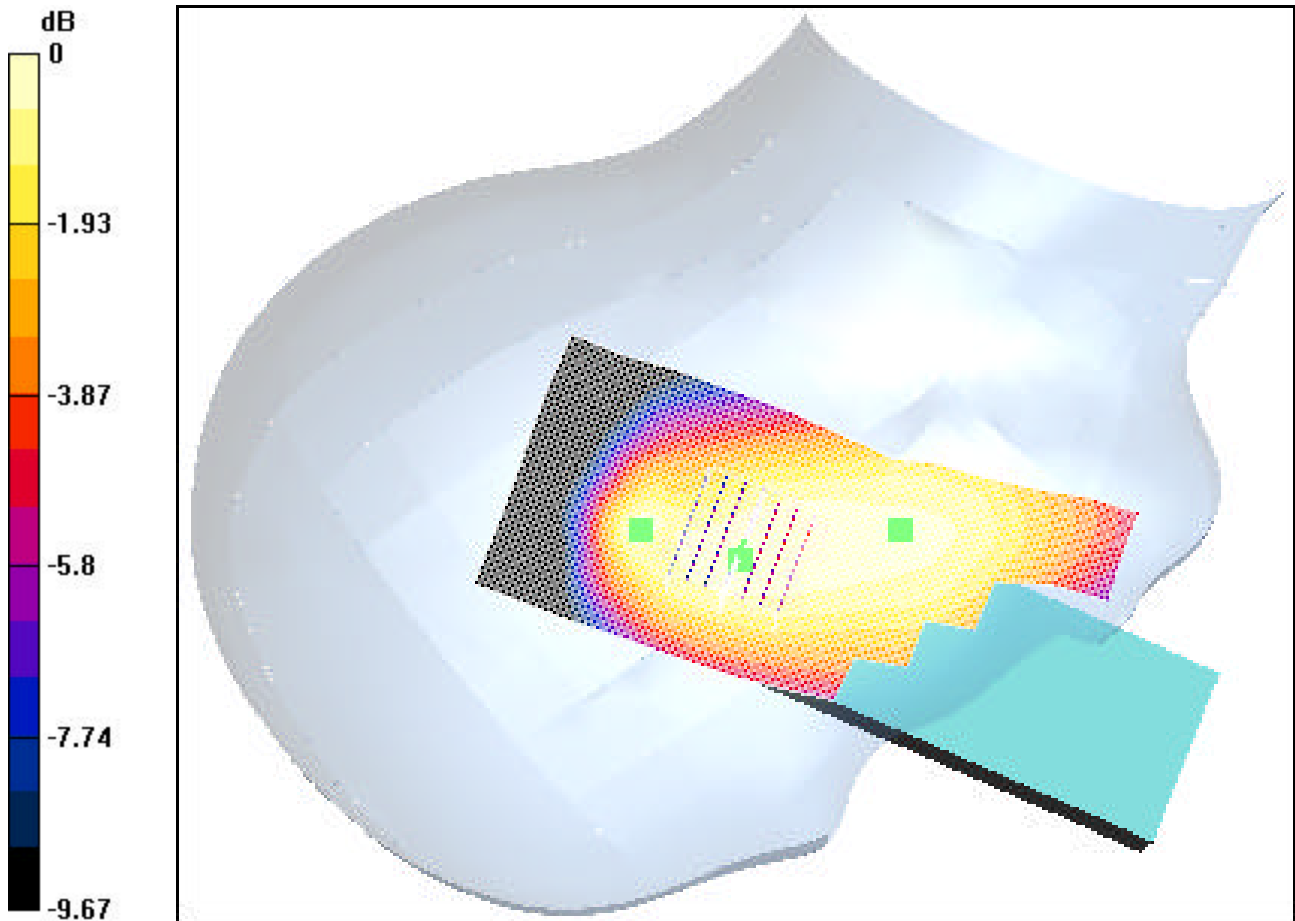

0 dB = 0.207mW/g

# PCTEST ENGINEERING LABORATORY, INC.

**DUT: SCP -7300; Type: SANYO Tri Mode Phone; Serial: FCC1**

Communication System: AMPS; Frequency: 836.49 MHz; Duty Cycle: 1:1

Medium: 835 Brain ( $\sigma = 0.9$  mho/m,  $\epsilon_r = 40.3$ ,  $\rho = 1000$  kg/m<sup>3</sup>)

Phantom section: Left Section

Test Date: 10-31-2003; Ambient Temp: 20.8°C; Tissue Temp: 19.0°C

Probe: ES3DV2 - SN3022; ConvF(6.1, 6.1, 6.1); Calibrated: 9/23/2003

Sensor-Surface: 4mm (Mechanical Surface Detection)

Electronics: DAE3 SN330; Calibrated: 12/1/2002

Phantom: SAM 12b; Type: SAM 4.0; Serial: TP:1197

Measurement SW: DASY4, V4.1 Build 47; Postprocessing SW: SEMCAD, V1.8 Build 62

## Ch.383, Touch, Ant Out, Standard Battery

**Area Scan (51x151x1):** Measurement grid: dx=15mm, dy=15mm

**Zoom Scan (7x7x7)/Cube 0:** Measurement grid: dx=5mm, dy=5mm, dz=5mm

Peak SAR (extrapolated) = 1.7 W/kg

SAR(1 g) = 0.956 mW/g; SAR(10 g) = 0.663 mW/g

Reference Value = 11.5 V/m

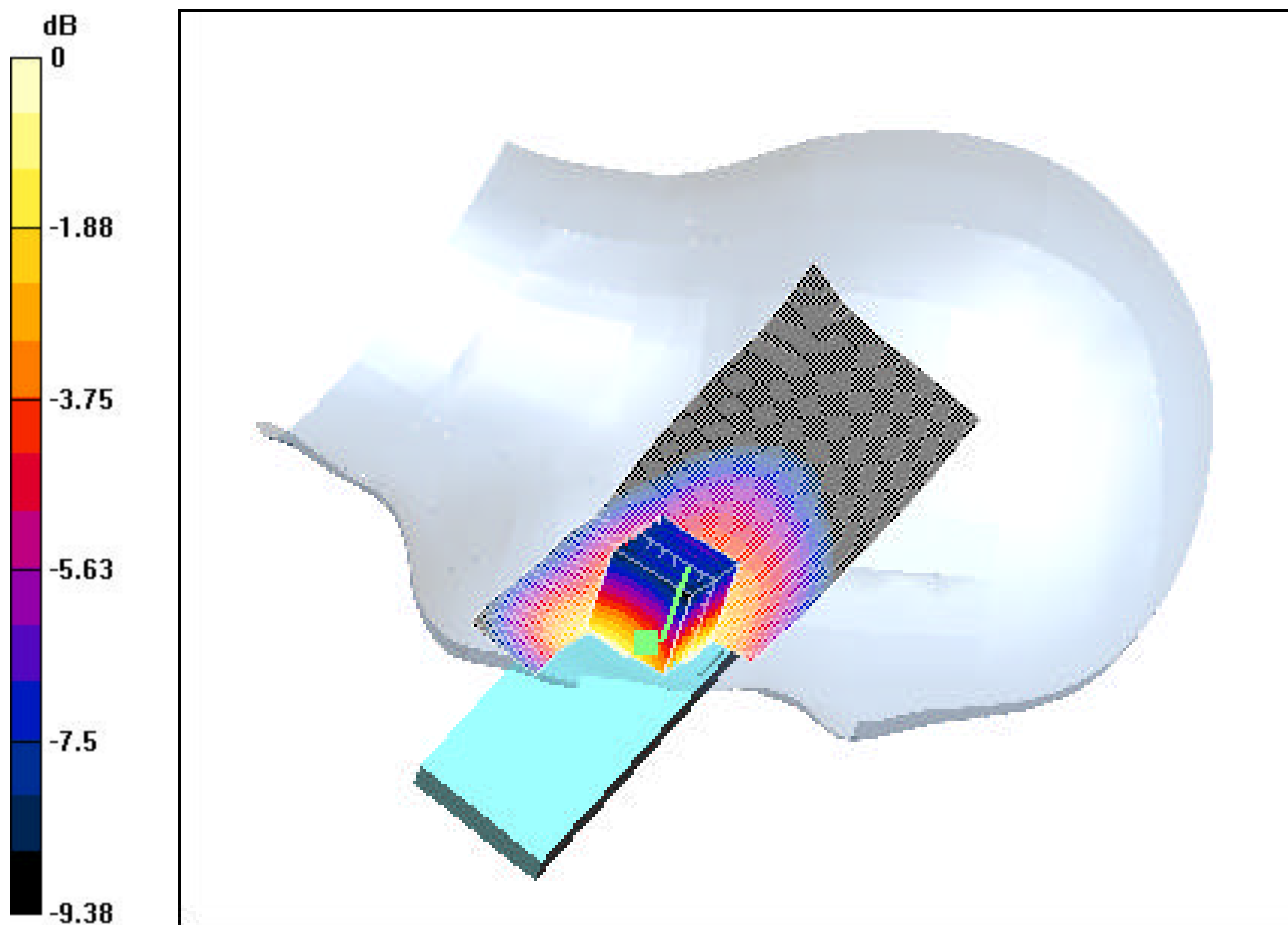

0 dB = 1.03mW/g

# PCTEST ENGINEERING LABORATORY, INC.

**DUT: SCP -7300; Type: SANYO Tri Mode Phone; Serial: FCC1**

Communication System: AMPS; Frequency: 836.49 MHz; Duty Cycle: 1:1

Medium: 835 Brain ( $\sigma = 0.9$  mho/m,  $\epsilon_r = 40.3$ ,  $\rho = 1000$  kg/m<sup>3</sup>)

Phantom section: Left Section

Test Date: 11-04-2003; Ambient Temp: 22.9°C; Tissue Temp: 21.6°C

Probe: ES3DV2 - SN3022; ConvF(6.1, 6.1, 6.1); Calibrated: 9/23/2003

Sensor-Surface: 3mm (Mechanical Surface Detection)

Electronics: DAE3 SN330; Calibrated: 12/1/2002

Phantom: SAM 12b; Type: SAM 4.0; Serial: TP:1197

Measurement SW: DAS4, V4.1 Build 47; Postprocessing SW: SEMCAD, V1.8 Build 62

## Ch.383, Tilt, Ant Out, Standard Battery

**Area Scan (61x141x1):** Measurement grid: dx=15mm, dy=15mm

**Zoom Scan (7x7x7)/Cube 0:** Measurement grid: dx=5mm, dy=5mm, dz=5mm

Peak SAR (extrapolated) = 0.303 W/kg

SAR(1 g) = 0.232 mW/g; SAR(10 g) = 0.179 mW/g

Reference Value = 11.8 V/m

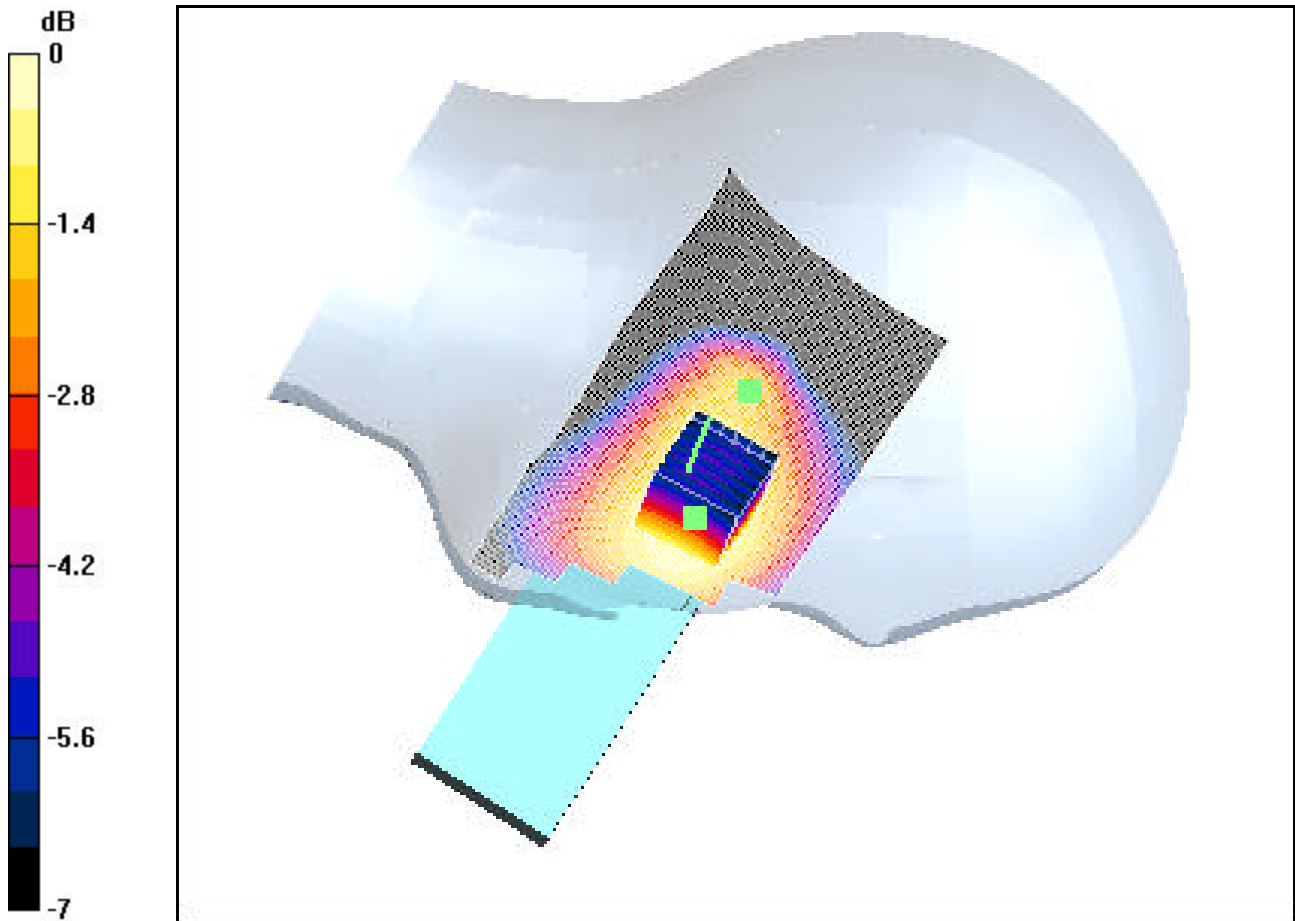

0 dB = 0.255mW/g

# PCTEST ENGINEERING LABORATORY, INC.

**DUT: SCP -7300; Type: SANYO Tri Mode Phone; Serial: FCC1**

Communication System: Cellular CDMA; Frequency: 836.49 MHz; Duty Cycle: 1:1

Medium: 835 Brain ( $\sigma = 0.9$  mho/m,  $\epsilon_r = 40.3$ ,  $\rho = 1000$  kg/m<sup>3</sup>)

Phantom section: Right Section

Test Date: 10-28-2003; Ambient Temp: 20.2°C; Tissue Temp: 18.2°C

Probe: ES3DV2 - SN3022; ConvF(6.1, 6.1, 6.1); Calibrated: 9/23/2003

Sensor-Surface: 4mm (Mechanical Surface Detection)

Electronics: DAE3 SN330; Calibrated: 12/1/2002

Phantom: SAM 12b; Type: SAM 4.0; Serial: TP:1197

Measurement SW: DASY4, V4.1 Build 47; Postprocessing SW: SEMCAD, V1.8 Build 62

## Ch.0383, Touch, Ant Out, Standard Battery

**Area Scan (51x151x1):** Measurement grid: dx=15mm, dy=15mm

**Zoom Scan (7x7x7)/Cube 0:** Measurement grid: dx=5mm, dy=5mm, dz=5mm

Peak SAR (extrapolated) = 1.63 W/kg

SAR(1 g) = 0.988 mW/g; SAR(10 g) = 0.637 mW/g

Reference Value = 12 V/m

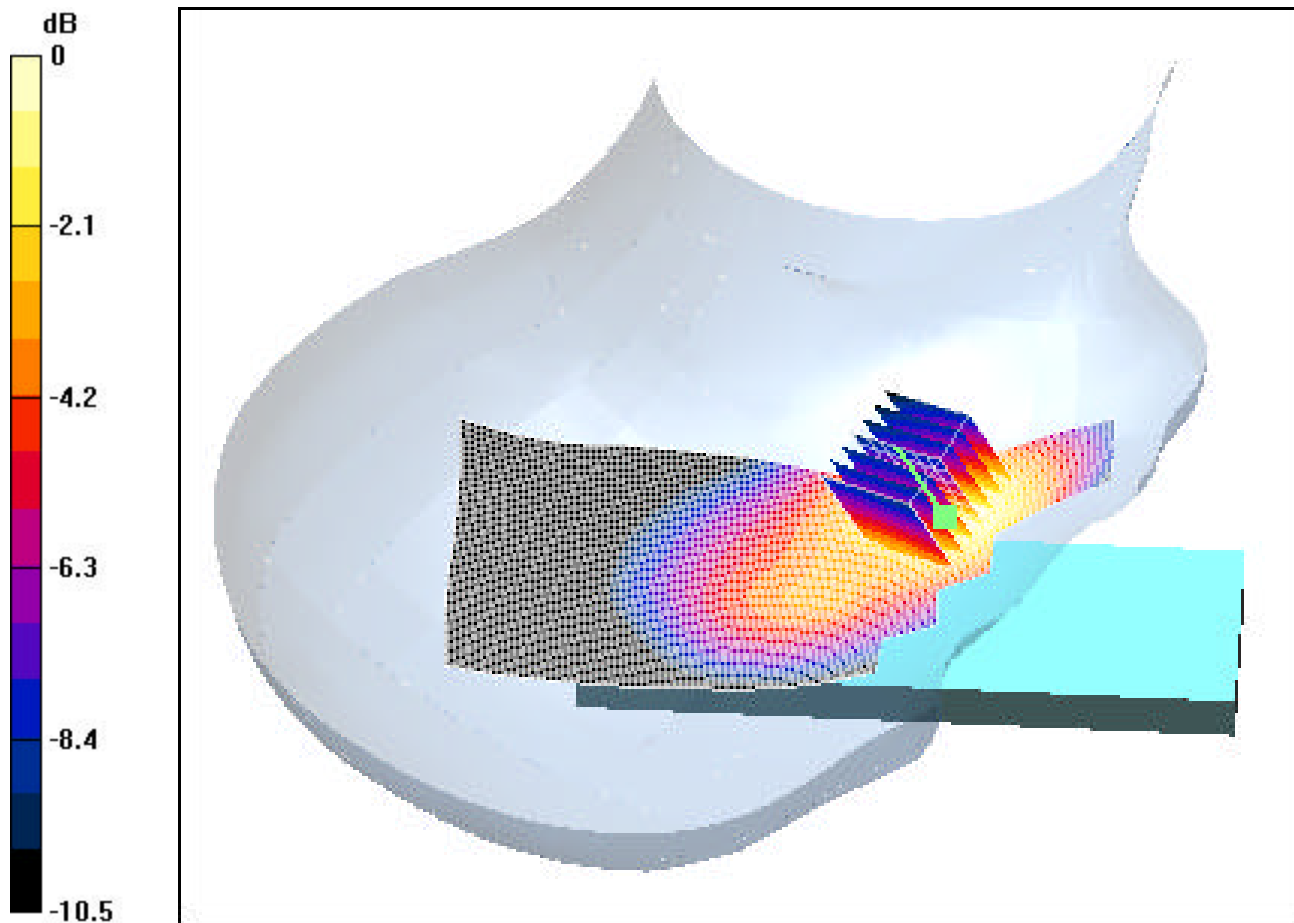

0 dB = 1.07mW/g

# PCTEST ENGINEERING LABORATORY, INC.

**DUT: SCP -7300; Type: SANYO Tri Mode Phone; Serial: FCC1**

Communication System: Cellular CDMA; Frequency: 836.49 MHz; Duty Cycle: 1:1

Medium: 835 Brain ( $\sigma = 0.9$  mho/m,  $\epsilon_r = 40.3$ ,  $\rho = 1000$  kg/m<sup>3</sup>)

Phantom section: Right Section

Test Date: 11-04-2003; Ambient Temp: 22.9°C; Tissue Temp: 21.6°C

Probe: ES3DV2 - SN3022; ConvF(6.1, 6.1, 6.1); Calibrated: 9/23/2003

Sensor-Surface: 3mm (Mechanical Surface Detection)

Electronics: DAE3 SN330; Calibrated: 12/1/2002

Phantom: SAM 12b; Type: SAM 4.0; Serial: TP:1197

Measurement SW: DASY4, V4.1 Build 47; Postprocessing SW: SEMCAD, V1.8 Build 62

## Ch.0383, Tilt, Ant Out, Standard Battery

**Area Scan (51x151x1):** Measurement grid: dx=15mm, dy=15mm

**Zoom Scan (7x7x7)/Cube 0:** Measurement grid: dx=5mm, dy=5mm, dz=5mm

Peak SAR (extrapolated) = 0.243 W/kg

SAR(1 g) = 0.182 mW/g; SAR(10 g) = 0.136 mW/g

Reference Value = 11.4 V/m

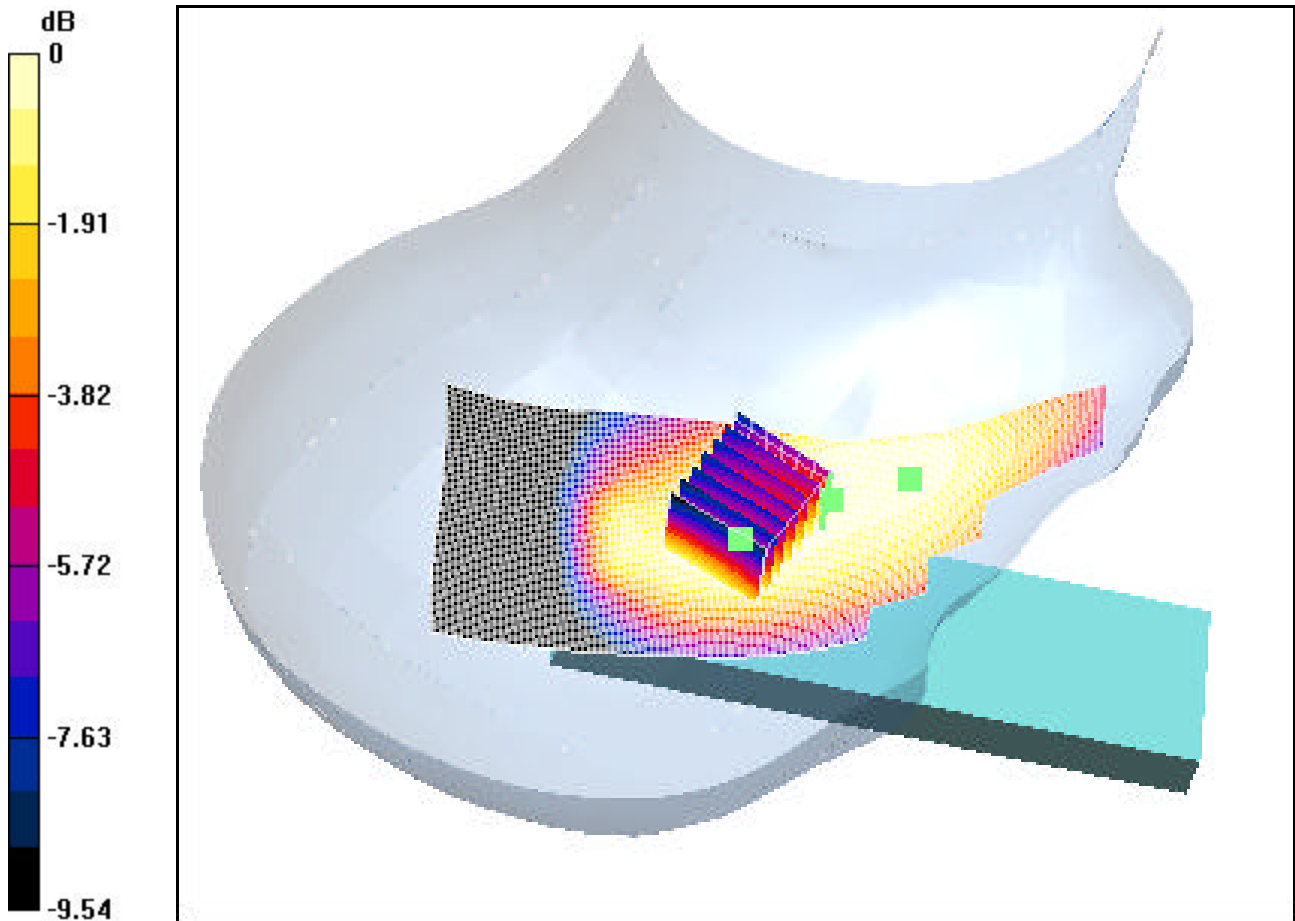

0 dB = 0.205mW/g

# PCTEST ENGINEERING LABORATORY, INC.

**DUT: SCP -7300; Type: SANYO Tri Mode Phone; Serial: FCC1**

Communication System: Cellular CDMA; Frequency: 836.49 MHz; Duty Cycle: 1:1

Medium: 835 Brain ( $\sigma = 0.9$  mho/m,  $\epsilon_r = 40.3$ ,  $\rho = 1000$  kg/m<sup>3</sup>)

Phantom section: Left Section

Test Date: 10-31-2003; Ambient Temp: 20.8°C; Tissue Temp: 19.0°C

Probe: ES3DV2 - SN3022; ConvF(6.1, 6.1, 6.1); Calibrated: 9/23/2003

Sensor-Surface: 4mm (Mechanical Surface Detection)

Electronics: DAE3 SN330; Calibrated: 12/1/2002

Phantom: SAM 12b; Type: SAM 4.0; Serial: TP:1197

Measurement SW: DAS4, V4.1 Build 47; Postprocessing SW: SEMCAD, V1.8 Build 62

## Ch.0383, Touch, Ant Out, Standard Battery

**Area Scan (51x151x1):** Measurement grid: dx=15mm, dy=15mm

**Zoom Scan (7x7x7)/Cube 0:** Measurement grid: dx=5mm, dy=5mm, dz=5mm

Peak SAR (extrapolated) = 1.49 W/kg

SAR(1 g) = 0.869 mW/g; SAR(10 g) = 0.599 mW/g

Reference Value = 10.9 V/m

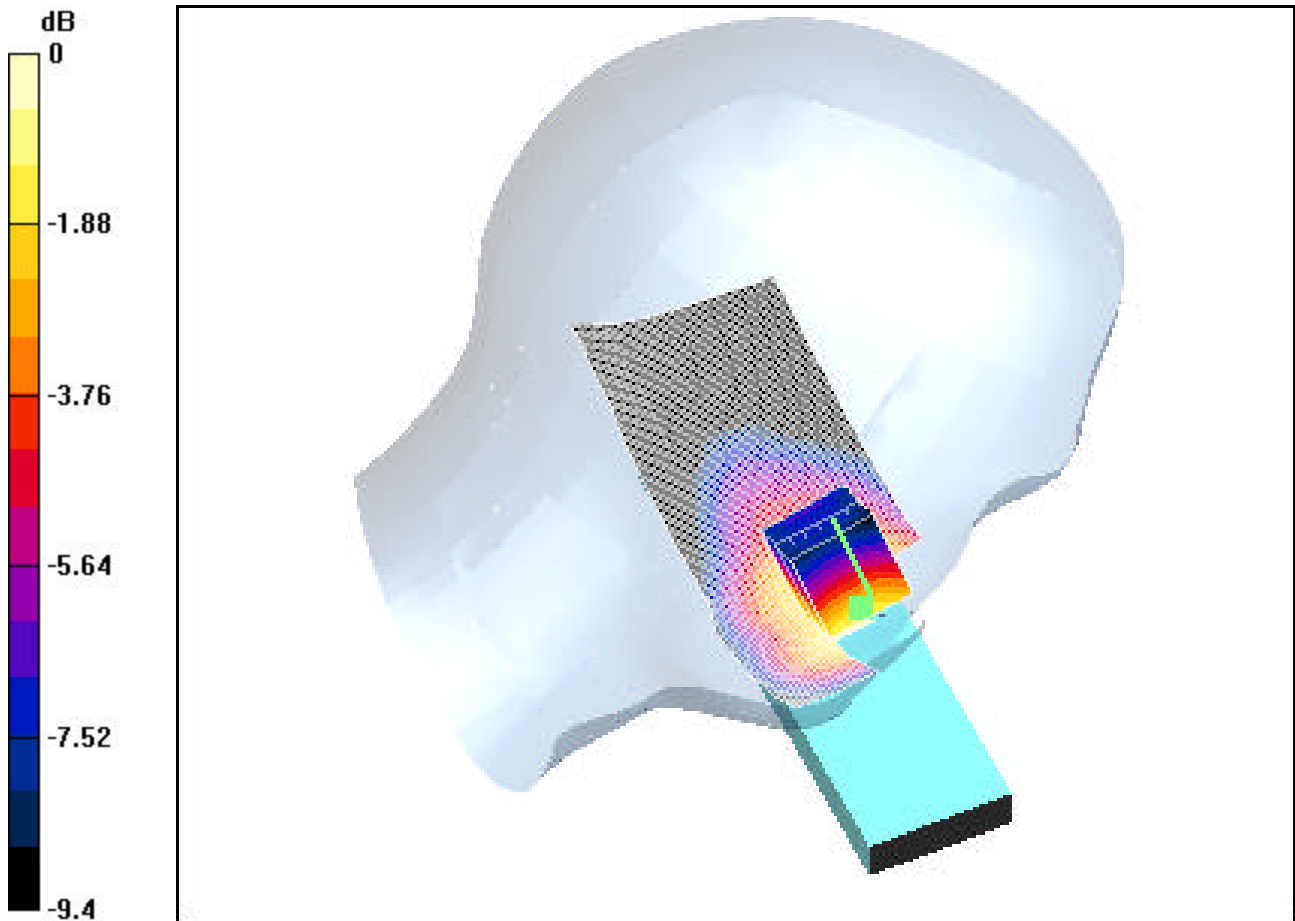

0 dB = 0.929mW/g



# PCTEST ENGINEERING LABORATORY, INC.

**DUT: SCP -7300; Type: SANYO Tri Mode Phone; Serial: FCC1**

Communication System: Cellular CDMA; Frequency: 836.49 MHz; Duty Cycle: 1:1

Medium: 835 Brain ( $\sigma = 0.9$  mho/m,  $\epsilon_r = 40.3$ ,  $\rho = 1000$  kg/m<sup>3</sup>)

Phantom section: Left Section

Test Date: 11-05-2003; Ambient Temp: 23.8°C; Tissue Temp: 22.3°C

Probe: ES3DV2 - SN3022; ConvF(6.1, 6.1, 6.1); Calibrated: 9/23/2003

Sensor-Surface: 3mm (Mechanical Surface Detection)

Electronics: DAE3 SN330; Calibrated: 12/1/2002

Phantom: SAM 12b; Type: SAM 4.0; Serial: TP:1197

Measurement SW: DAS4, V4.1 Build 47; Postprocessing SW: SEMCAD, V1.8 Build 62

## Ch.0383, Tilt, Ant Out, Standard Battery

**Area Scan (61x151x1):** Measurement grid: dx=15mm, dy=15mm

**Zoom Scan (7x7x7)/Cube 0:** Measurement grid: dx=5mm, dy=5mm, dz=5mm

Peak SAR (extrapolated) = 0.264 W/kg

SAR(1 g) = 0.196 mW/g; SAR(10 g) = 0.152 mW/g

Reference Value = 12.1 V/m

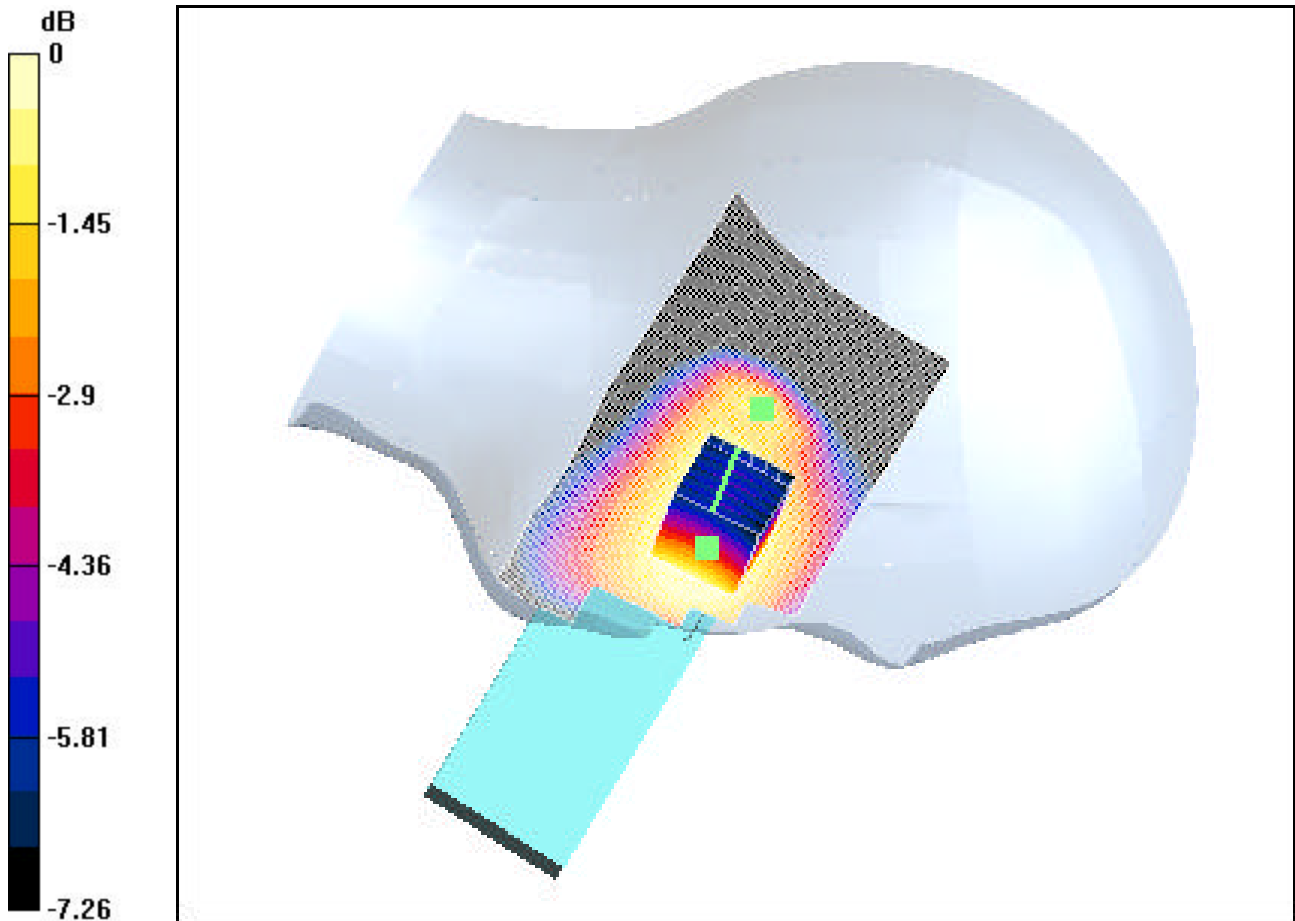

0 dB = 0.224mW/g

# PCTEST ENGINEERING LABORATORY, INC.

**DUT: SCP -7300; Type: SANYO Tri Mode Phone; Serial: FCC1**

Communication System: PCS CDMA; Frequency: 1851.25 MHz; Duty Cycle: 1:1

Medium: 1900 Brain ( $\sigma = 1.39$  mho/m,  $\epsilon_r = 41.02$ ,  $\rho = 1000$  kg/m<sup>3</sup>)

Phantom section: Right Section

Test Date: 10-27-2003; Ambient Temp: 22.8°C; Tissue Temp: 19.6°C

Probe: ES3DV2 - SN3022; ConvF(5, 5, 5); Calibrated: 9/23/2003

Sensor-Surface: 4mm (Mechanical Surface Detection)

Electronics: DAE3 SN330; Calibrated: 12/1/2002

Phantom: SAM 12b; Type: SAM 4.0; Serial: TP:1197

Measurement SW: DASY4, V4.1 Build 47; Postprocessing SW: SEMCAD, V1.8 Build 62

## Ch.0025, Touch, Ant In, Standard Battery

**Area Scan (51x141x1):** Measurement grid: dx=15mm, dy=15mm

**Zoom Scan (7x7x7)/Cube 0:** Measurement grid: dx=5mm, dy=5mm, dz=5mm

Peak SAR (extrapolated) = 1.74 W/kg

SAR(1 g) = 0.973 mW/g; SAR(10 g) = 0.540 mW/g

Reference Value = 7.12 V/m

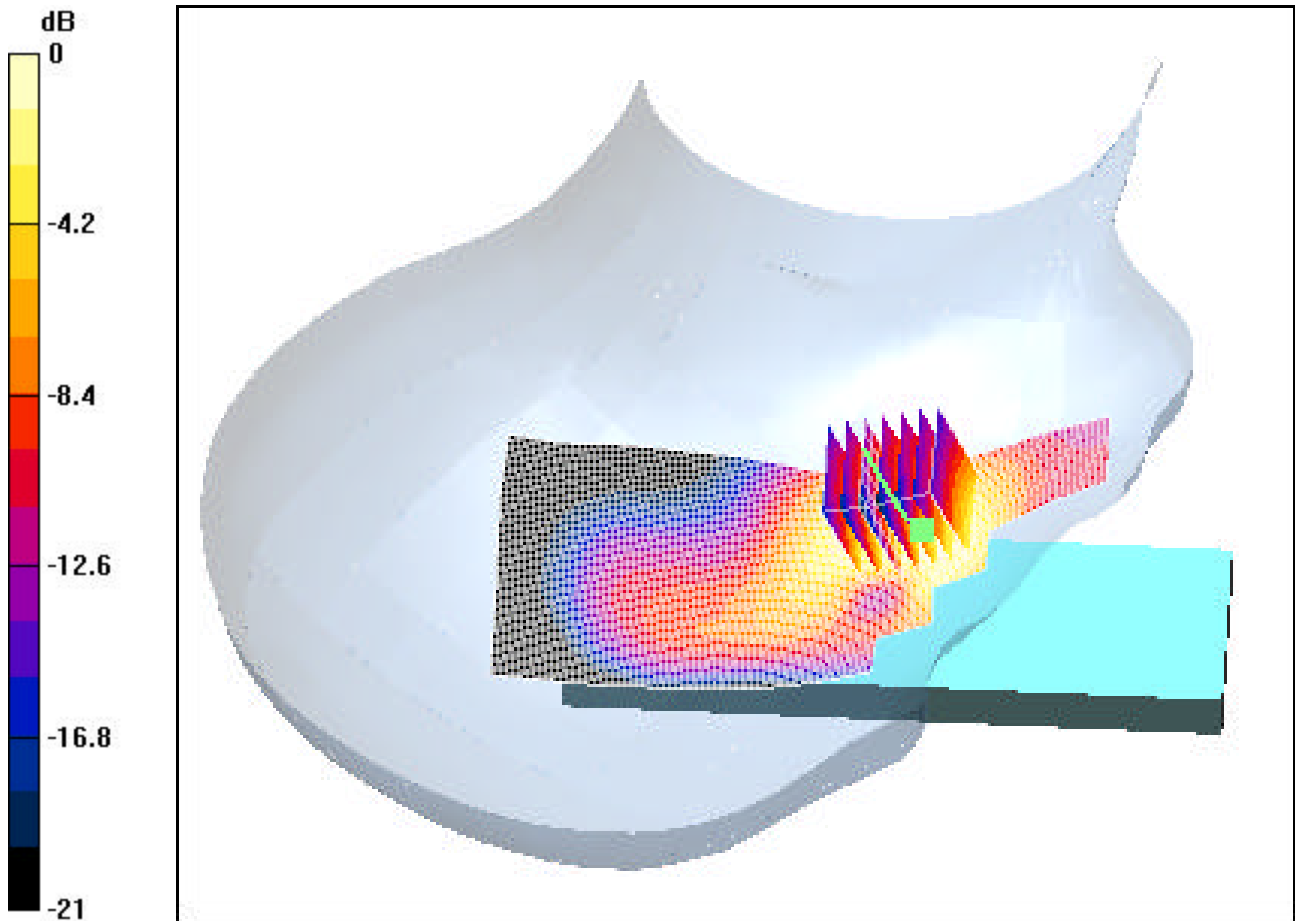

0 dB = 1.05mW/g

# PCTEST ENGINEERING LABORATORY, INC.

**DUT: SCP -7300; Type: SANYO Tri Mode Phone; Serial: FCC1**

Communication System: PCS CDMA; Frequency: 1880 MHz; Duty Cycle: 1:1

Medium: 1900 Brain ( $\sigma = 1.39$  mho/m,  $\epsilon_r = 41.02$ ,  $\rho = 1000$  kg/m<sup>3</sup>)

Phantom section: Right Section

Test Date: 11-03-2003; Ambient Temp: 22.5°C; Tissue Temp: 21.4°C

Probe: ES3DV2 - SN3022; ConvF(5, 5, 5); Calibrated: 9/23/2003

Sensor-Surface: 4mm (Mechanical Surface Detection)

Electronics: DAE3 SN330; Calibrated: 12/1/2002

Phantom: SAM 12b; Type: SAM 4.0; Serial: TP:1197

Measurement SW: DASY4, V4.1 Build 47; Postprocessing SW: SEMCAD, V1.8 Build 62

## Ch.0600, Tilt, Ant In, Standard Battery

**Area Scan (51x141x1):** Measurement grid: dx=15mm, dy=15mm

**Zoom Scan (7x7x7)/Cube 0:** Measurement grid: dx=5mm, dy=5mm, dz=5mm

Peak SAR (extrapolated) = 0.190 W/kg

SAR(1 g) = 0.117 mW/g; SAR(10 g) = 0.069 mW/g

Reference Value = 9.28 V/m

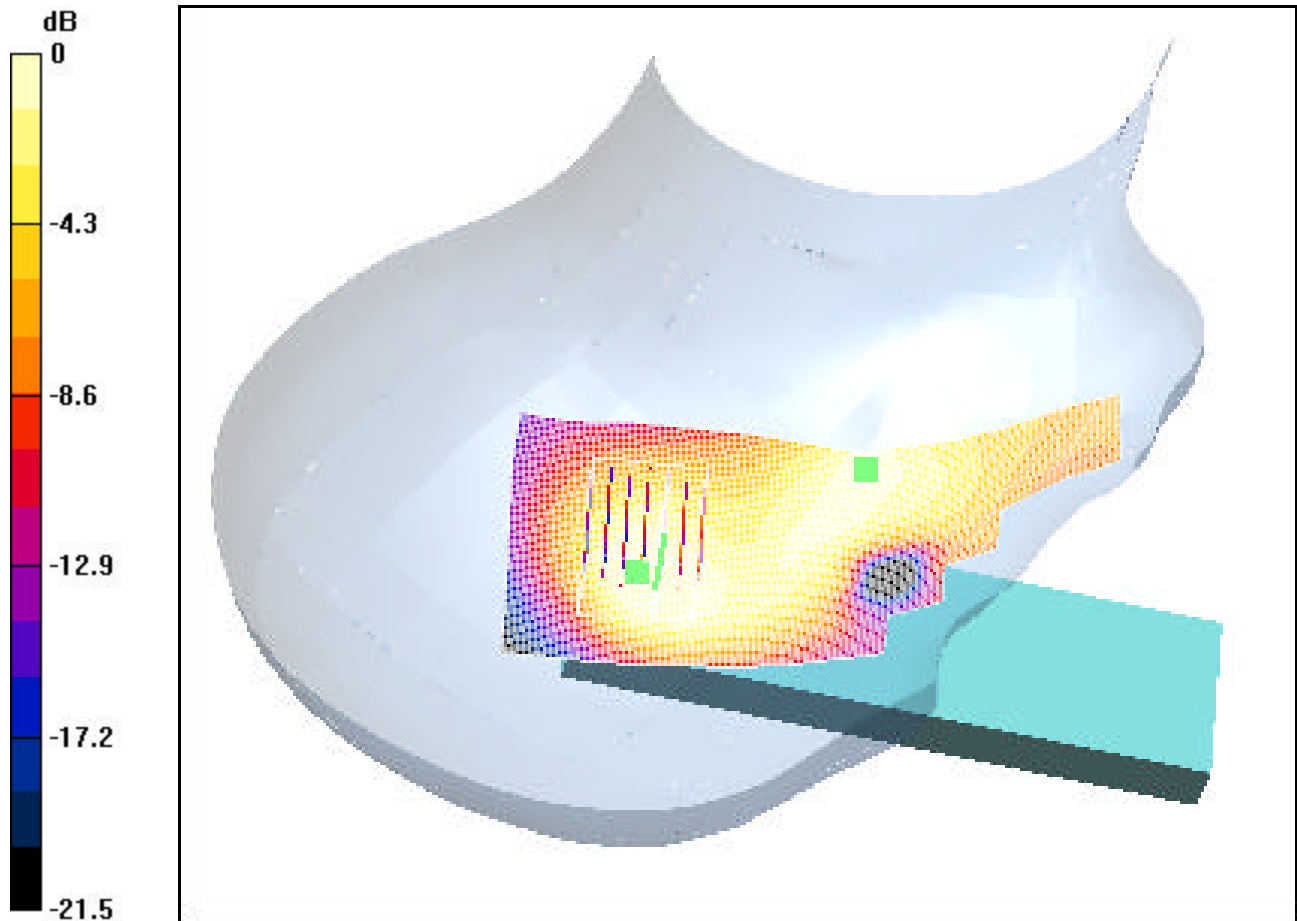

0 dB = 0.127mW/g

# PCTEST ENGINEERING LABORATORY, INC.

**DUT: SCP -7300; Type: SANYO Tri Mode Phone; Serial: FCC1**

Communication System: PCS CDMA; Frequency: 1851.25 MHz; Duty Cycle: 1:1

Medium: 1900 Brain ( $\sigma = 1.39$  mho/m,  $\epsilon_r = 41.02$ ,  $\rho = 1000$  kg/m<sup>3</sup>)

Phantom section: Left Section

Test Date: 10-27-2003; Ambient Temp: 22.8°C; Tissue Temp: 19.6°C

Probe: ES3DV2 - SN3022; ConvF(5, 5, 5); Calibrated: 9/23/2003

Sensor-Surface: 4mm (Mechanical Surface Detection)

Electronics: DAE3 SN330; Calibrated: 12/1/2002

Phantom: SAM 12b; Type: SAM 4.0; Serial: TP:1197

Measurement SW: DASY4, V4.1 Build 47; Postprocessing SW: SEMCAD, V1.8 Build 62

## Ch.0025, Touch, Ant In, Standard Battery

**Area Scan (51x141x1):** Measurement grid: dx=15mm, dy=15mm

**Zoom Scan (7x7x7)/Cube 0:** Measurement grid: dx=5mm, dy=5mm, dz=5mm

Peak SAR (extrapolated) = 1.07 W/kg

SAR(1 g) = 0.615 mW/g; SAR(10 g) = 0.351 mW/g

Reference Value = 6.04 V/m

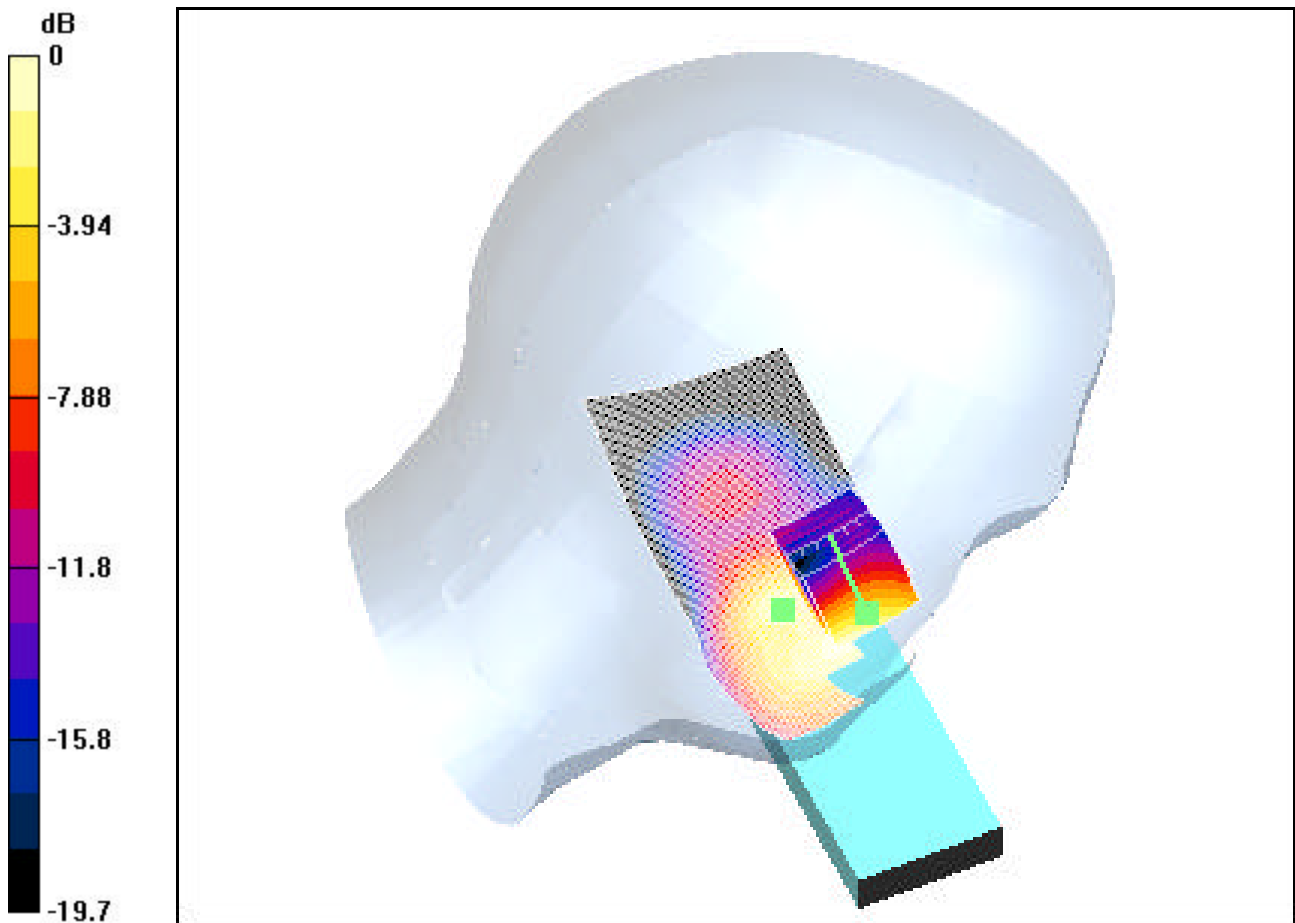

0 dB = 0.681mW/g

# PCTEST ENGINEERING LABORATORY, INC.

**DUT: SCP-7300; Type: SANYO Tri Mode Phone; Serial: FCC1**

Communication System: PCS CDMA; Frequency: 1880 MHz; Duty Cycle: 1:1

Medium: 1900 Brain ( $\sigma = 1.39$  mho/m,  $\epsilon_r = 41.02$ ,  $\rho = 1000$  kg/m<sup>3</sup>)

Phantom section: Left Section

Test Date: 11-03-2003; Ambient Temp: 22.5°C; Tissue Temp: 21.4°C

Probe: ES3DV2 - SN3022; ConvF(5, 5, 5); Calibrated: 9/23/2003

Sensor-Surface: 4mm (Mechanical Surface Detection)

Electronics: DAE3 SN330; Calibrated: 12/1/2002

Phantom: SAM 12b; Type: SAM 4.0; Serial: TP:1197

Measurement SW: DASY4, V4.1 Build 47; Postprocessing SW: SEMCAD, V1.8 Build 62

## Ch.0600, Tilt, Ant Out, Standard Battery

**Area Scan (51x151x1):** Measurement grid: dx=15mm, dy=15mm

**Zoom Scan (7x7x7)/Cube 0:** Measurement grid: dx=5mm, dy=5mm, dz=5mm

Peak SAR (extrapolated) = 0.210 W/kg

SAR(1 g) = 0.121 mW/g; SAR(10 g) = 0.067 mW/g

Reference Value = 6.18 V/m

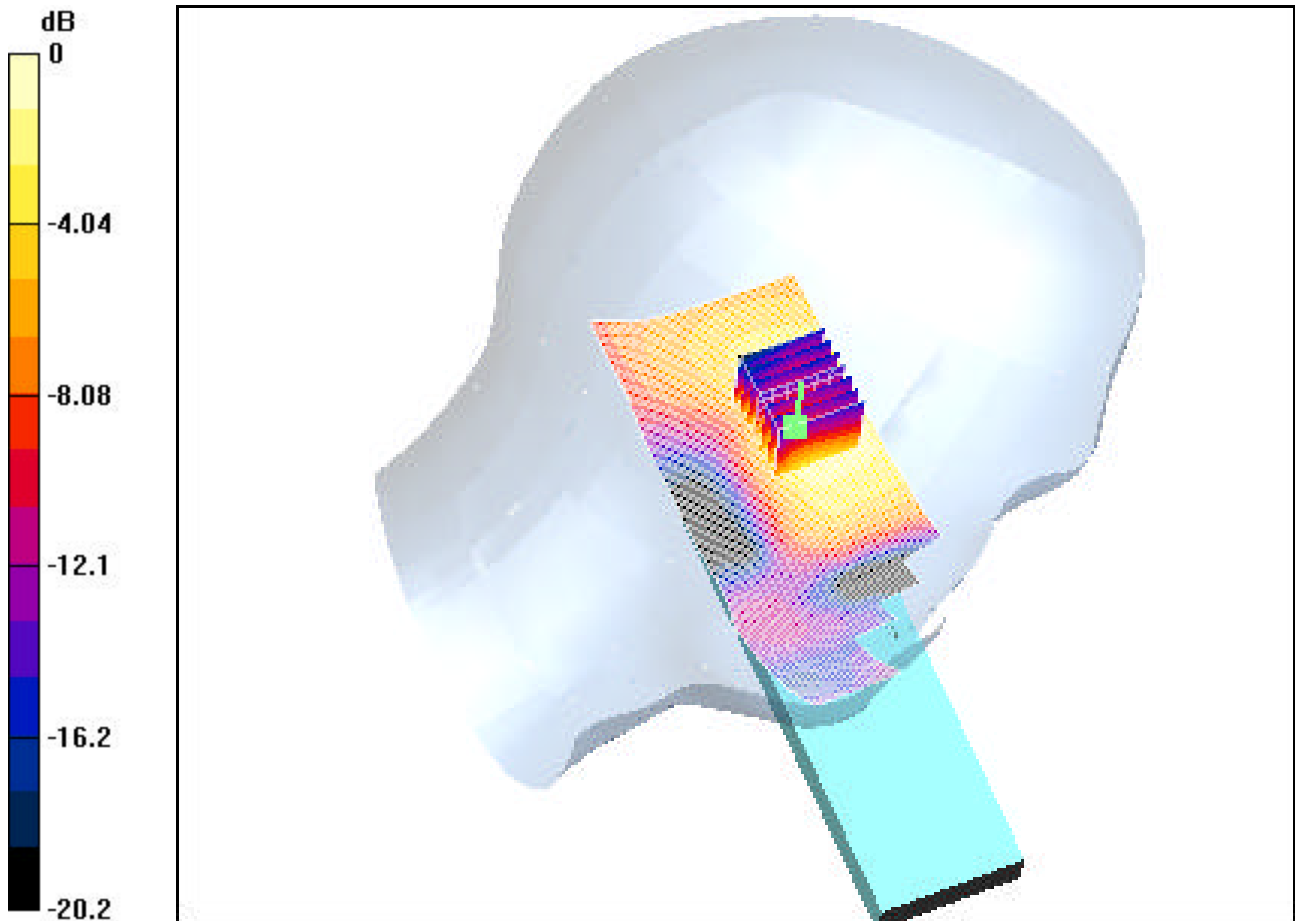

0 dB = 0.136mW/g

# PCTEST ENGINEERING LABORATORY, INC.

**DUT: SCP -7300; Type: SANYO Tri Mode Phone; Serial: FCC1**

Communication System: AMPS; Frequency: 836.49 MHz; Duty Cycle: 1:1

Medium: 835 Muscle ( $\sigma = 0.99$  mho/m,  $\epsilon_r = 53.23$ ,  $\rho = 1000$  kg/m<sup>3</sup>)

Phantom section: Flat Section; Spac: 1.9 cm

Test Date: 10-30-2003; Ambient Temp: 21.8°C; Tissue Temp: 20.6°C

Probe: ES3DV2 - SN3022; ConvF(6, 6, 6); Calibrated: 9/23/2003

Sensor-Surface: 4mm (Mechanical Surface Detection)

Electronics: DAE3 SN330; Calibrated: 12/1/2002

Phantom: SAM 12b; Type: SAM 4.0; Serial: TP:1197

Measurement SW: DASY4, V4.1 Build 47; Postprocessing SW: SEMCAD, V1.8 Build 62

## Ch.383, Ant Out, Standard Battery

**Area Scan (51x141x1):** Measurement grid: dx=15mm, dy=15mm

**Zoom Scan (7x7x7)/Cube 0:** Measurement grid: dx=5mm, dy=5mm, dz=5mm

Peak SAR (extrapolated) = 1.49 W/kg

SAR(1 g) = 1.08 mW/g; SAR(10 g) = 0.750 mW/g

Reference Value = 27 V/m

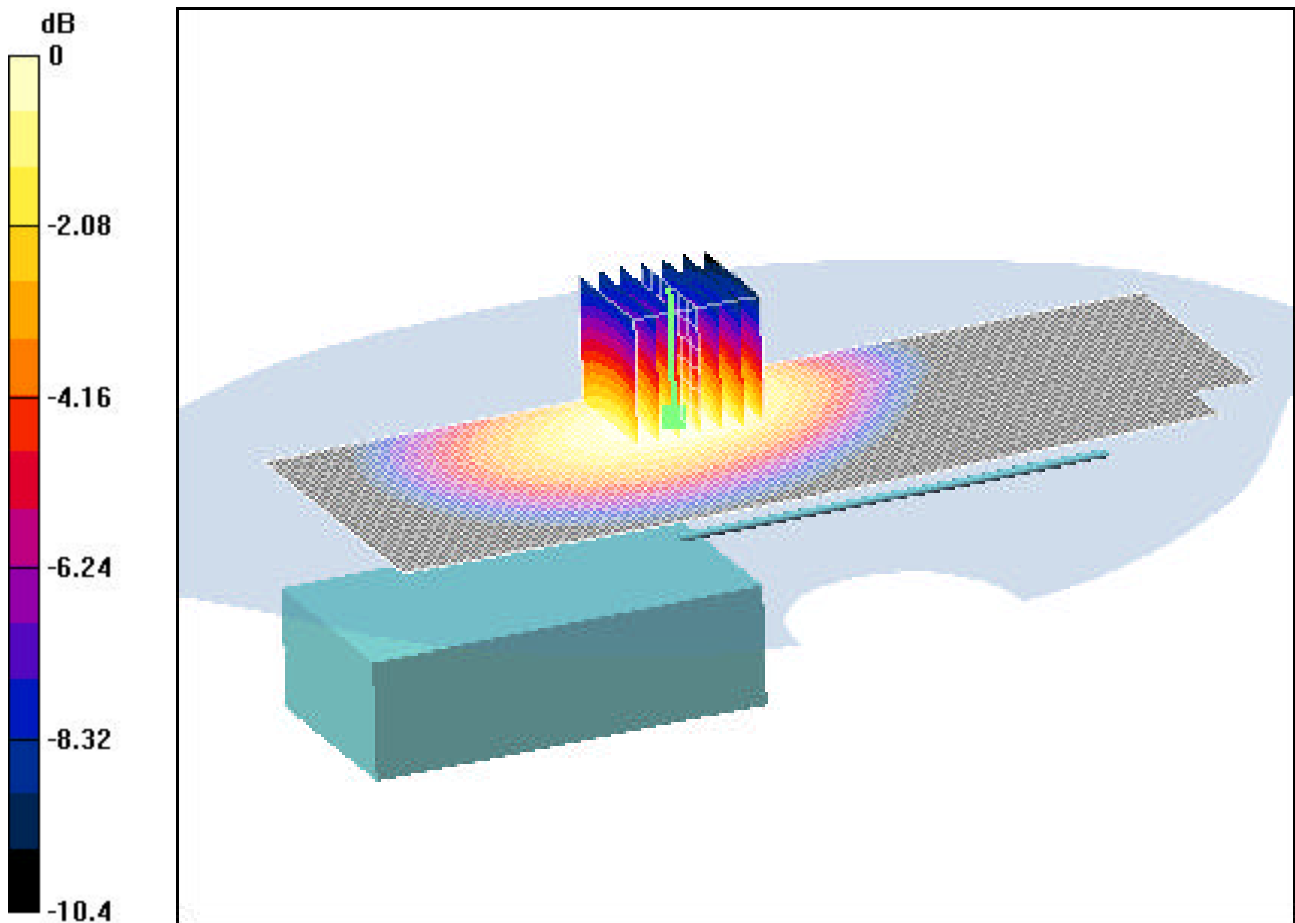

0 dB = 1.15mW/g

# PCTEST ENGINEERING LABORATORY, INC.

**DUT: SCP -7300; Type: SANYO Tri Mode Phone; Serial: FCC1**

Communication System: Cellular CDMA; Frequency: 836.49 MHz; Duty Cycle: 1:1

Medium: 835 Muscle ( $\sigma = 0.99$  mho/m,  $\epsilon_r = 53.23$ ,  $\rho = 1000$  kg/m<sup>3</sup>)

Phantom section: Flat Section; Space: 1.9 cm

Test Date: 10-30-2003; Ambient Temp: 21.8°C; Tissue Temp: 20.6°C

Probe: ES3DV2 - SN3022; ConvF(6, 6, 6); Calibrated: 9/23/2003

Sensor-Surface: 4mm (Mechanical Surface Detection)

Electronics: DAE3 SN330; Calibrated: 12/1/2002

Phantom: SAM 12b; Type: SAM 4.0; Serial: TP:1197

Measurement SW: DASY4, V4.1 Build 47; Postprocessing SW: SEMCAD, V1.8 Build 62

## Ch.0383, Ant Out, Standard Battery

**Area Scan (51x141x1):** Measurement grid: dx=15mm, dy=15mm

**Zoom Scan (7x7x7)/Cube 0:** Measurement grid: dx=5mm, dy=5mm, dz=5mm

Peak SAR (extrapolated) = 1.41 W/kg

SAR(1 g) = 1.01 mW/g; SAR(10 g) = 0.702 mW/g

Reference Value = 24.2 V/m

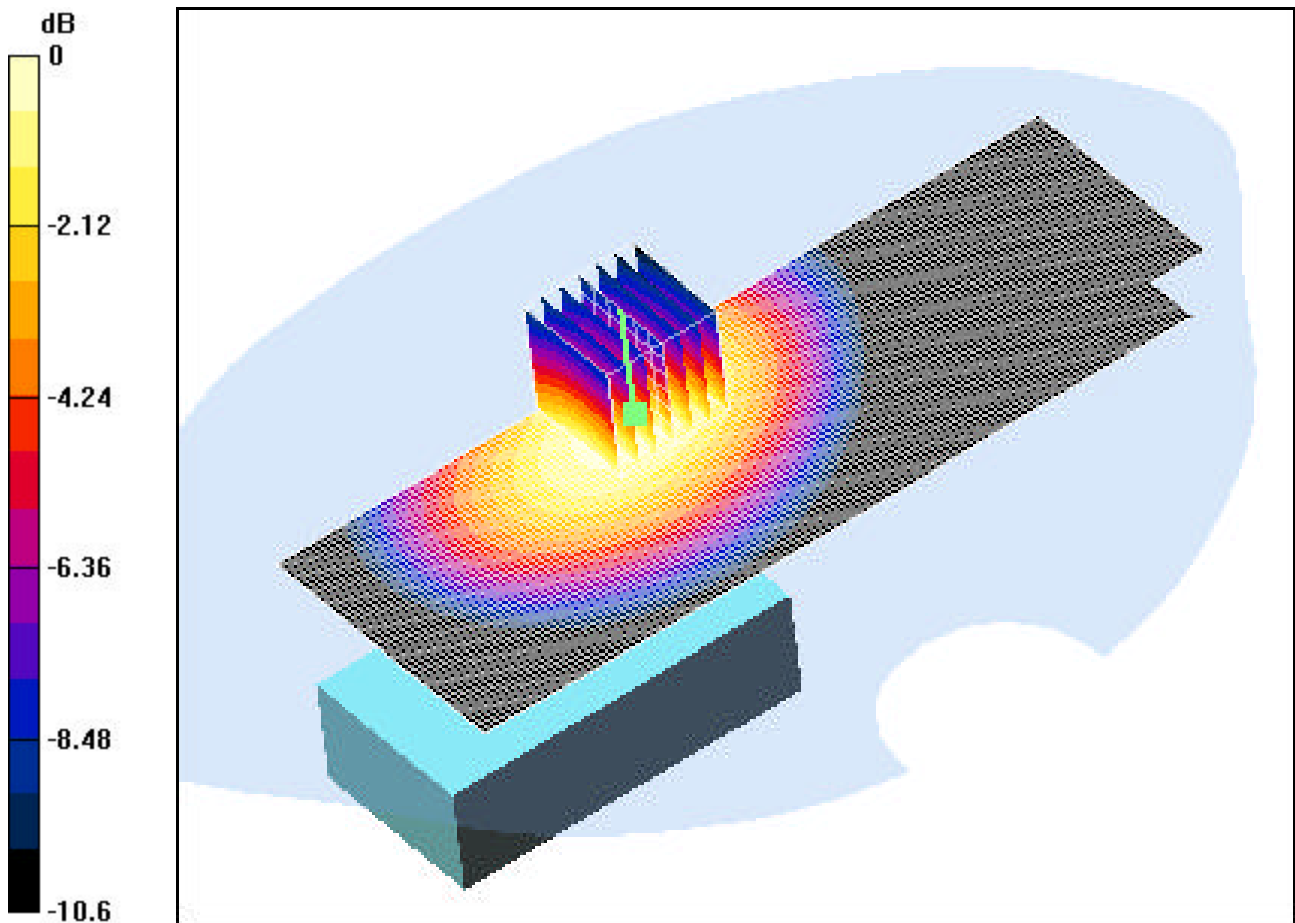

0 dB = 1.08mW/g

# PCTEST ENGINEERING LABORATORY, INC.

**DUT: SCP -7300; Type: SANYO Tri Mode Phone; Serial: FCC1**

Communication System: PCS CDMA; Frequency: 1880 MHz; Duty Cycle: 1:1

Medium: 1900 Muscle ( $\sigma = 1.58$  mho/m,  $\epsilon_r = 50.02$ ,  $\rho = 1000$  kg/m<sup>3</sup>)

Phantom section: Flat Section; Space: 1.9 cm

Test Date: 10-28-2003; Ambient Temp: 22.7°C; Tissue Temp: 21.1°C

Probe: ES3DV2 - SN3022; ConvF(4.5, 4.5, 4.5); Calibrated: 9/23/2003

Sensor-Surface: 4mm (Mechanical Surface Detection)

Electronics: DAE3 SN330; Calibrated: 12/1/2002

Phantom: SAM 12b; Type: SAM 4.0; Serial: TP:1197

Measurement SW: DASYS4, V4.1 Build 47; Postprocessing SW: SEMCAD, V1.8 Build 62

## Ch.0600, Ant In, Standard Battery

**Area Scan (51x91x1):** Measurement grid: dx=15mm, dy=15mm

**Zoom Scan (7x7x7)/Cube 0:** Measurement grid: dx=5mm, dy=5mm, dz=5mm

Peak SAR (extrapolated) = 1.17 W/kg

SAR(1 g) = 0.673 mW/g; SAR(10 g) = 0.370 mW/g

Reference Value = 16.5 V/m

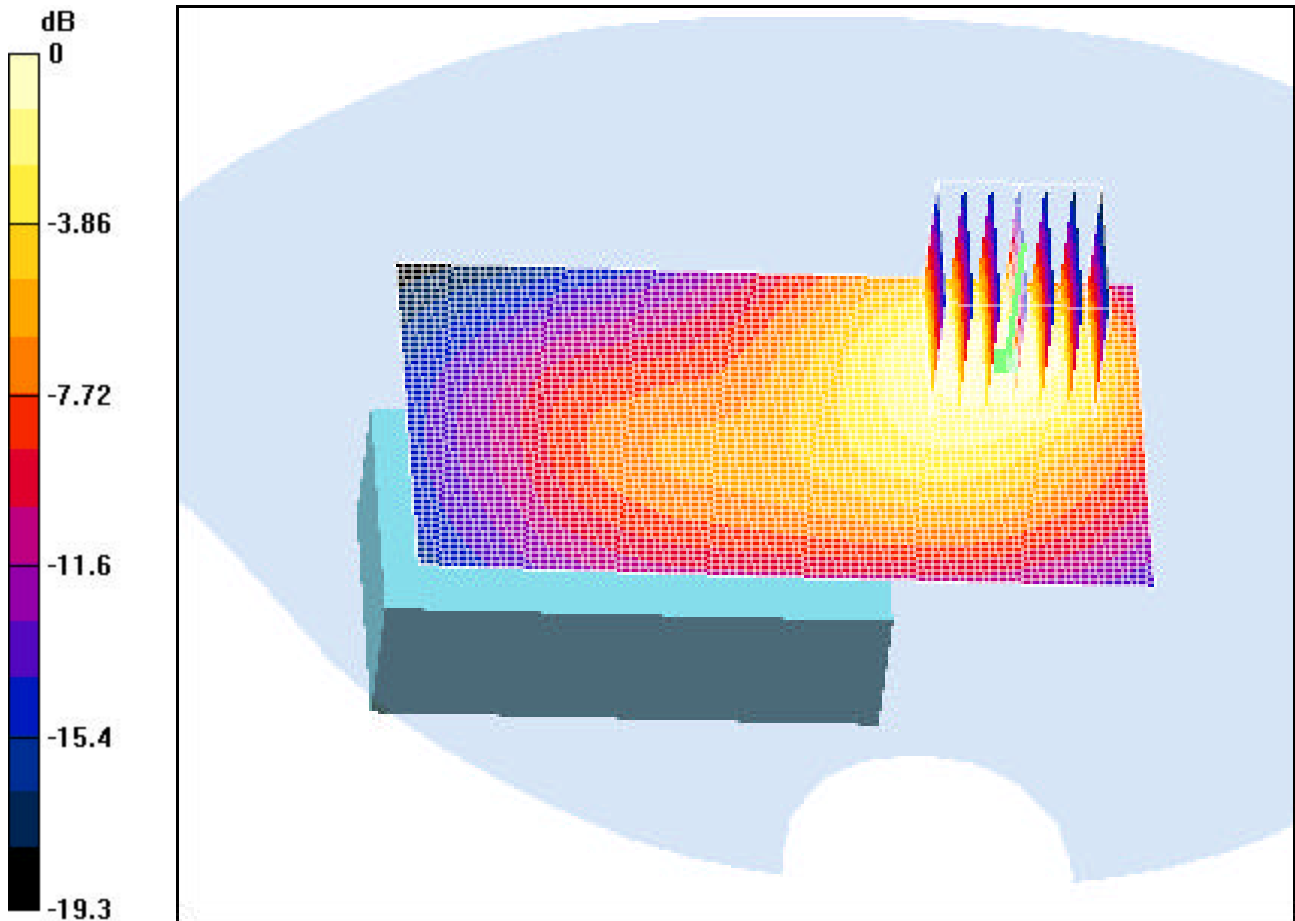

0 dB = 0.746mW/g



# PCTEST ENGINEERING LABORATORY, INC.

**DUT: SCP -7300; Type: SANYO Tri Mode Phone; Serial: FCC1**

Communication System: PCS CDMA; Frequency: 1880 MHz; Duty Cycle: 1:1

Medium: 1900 Brain ( $\sigma = 1.39$  mho/m,  $\epsilon_r = 41.02$ ,  $\rho = 1000$  kg/m<sup>3</sup>)

Phantom section: Flat Section; Space: 2.5 cm

Test Date: 11-05-2003; Ambient Temp: 23.2°C; Tissue Temp: 21.8°C

Probe: ES3DV2 - SN3022; ConvF(5, 5, 5); Calibrated: 9/23/2003

Sensor-Surface: 3mm (Mechanical Surface Detection)

Electronics: DAE3 SN330; Calibrated: 12/1/2002

Phantom: SAM 12b; Type: SAM 4.0; Serial: TP:1197

Measurement SW: DASY4, V4.1 Build 47; Postprocessing SW: SEMCAD, V1.8 Build 62

## **Ch.0600, Ant In, LCD Open, Standard Battery**

**Area Scan (61x131x1):** Measurement grid: dx=15mm, dy=15mm

**Zoom Scan (7x7x7)/Cube 0:** Measurement grid: dx=5mm, dy=5mm, dz=5mm

Peak SAR (extrapolated) = 0.106 W/kg

SAR(1 g) = 0.065 mW/g; SAR(10 g) = 0.040 mW/g

Reference Value = 2.03 V/m

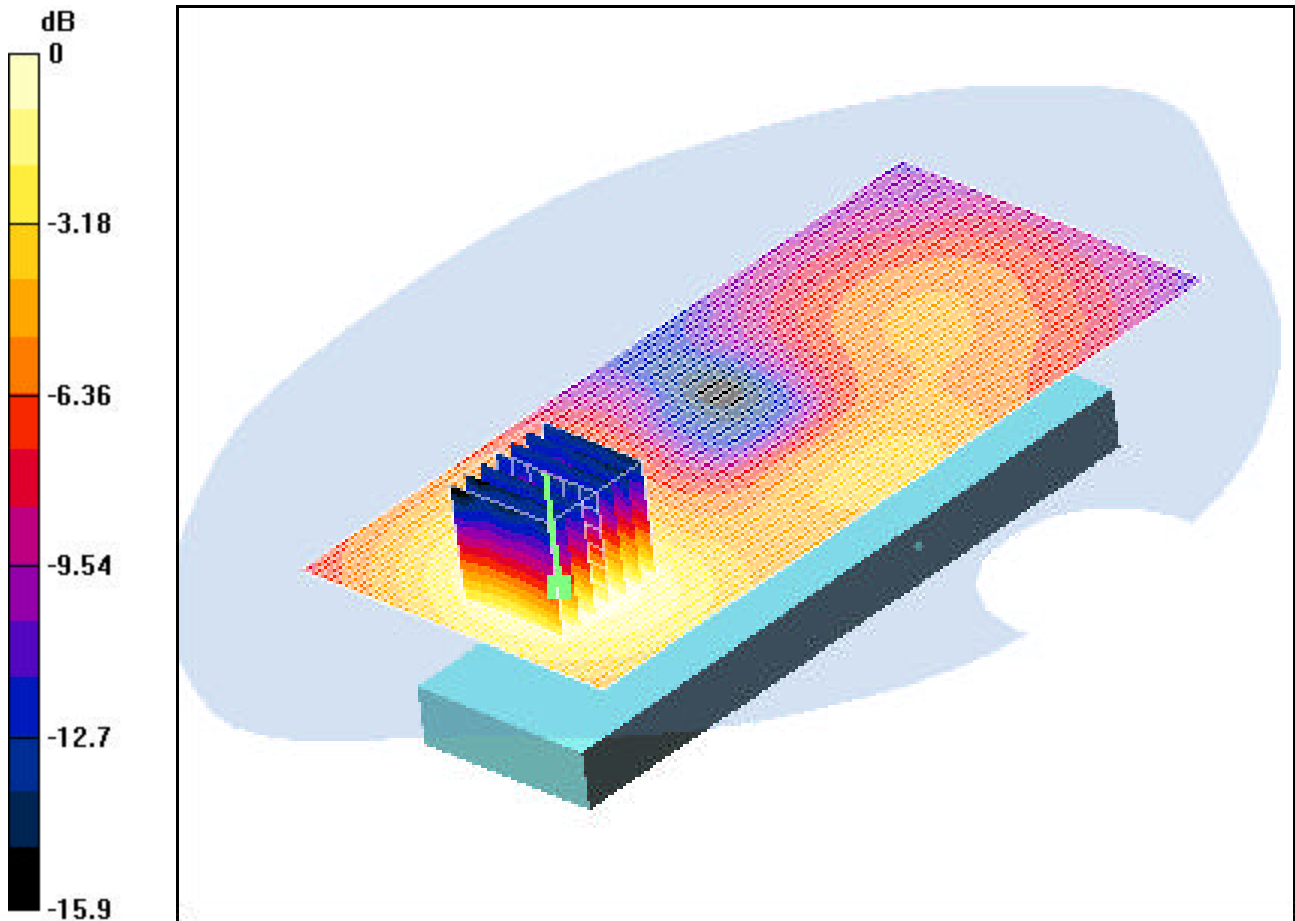

0 dB = 0.078mW/g

# PCTEST ENGINEERING LABORATORY, INC.

**DUT: SCP -7300; Type: SANYO Tri Mode Phone; Serial: FCC1**

Communication System: PCS CDMA; Frequency: 1880 MHz; Duty Cycle: 1:1

Medium: 1900 Brain ( $\sigma = 1.39$  mho/m,  $\epsilon_r = 41.02$ ,  $\rho = 1000$  kg/m<sup>3</sup>)

Phantom section: Flat Section

Test Date: 11-05-2003; Ambient Temp: 23.2°C; Tissue Temp: 21.8°C

Probe: ES3DV2 - SN3022; ConvF(5, 5, 5); Calibrated: 9/23/2003

Sensor-Surface: 3mm (Mechanical Surface Detection)

Electronics: DAE3 SN330; Calibrated: 12/1/2002

Phantom: SAM 12b; Type: SAM 4.0; Serial: TP:1197

Measurement SW: DASY4, V4.1 Build 47; Postprocessing SW: SEMCAD, V1.8 Build 62

**Ch.0600, Ant In, LCD Close, Standard Battery**

**Area Scan (61x101x1):** Measurement grid: dx=15mm, dy=15mm

**Zoom Scan (7x7x7)/Cube 0:** Measurement grid: dx=5mm, dy=5mm, dz=5mm

Peak SAR (extrapolated) = 0.198 W/kg

SAR(1 g) = 0.121 mW/g; SAR(10 g) = 0.074 mW/g

Reference Value = 9.1 V/m

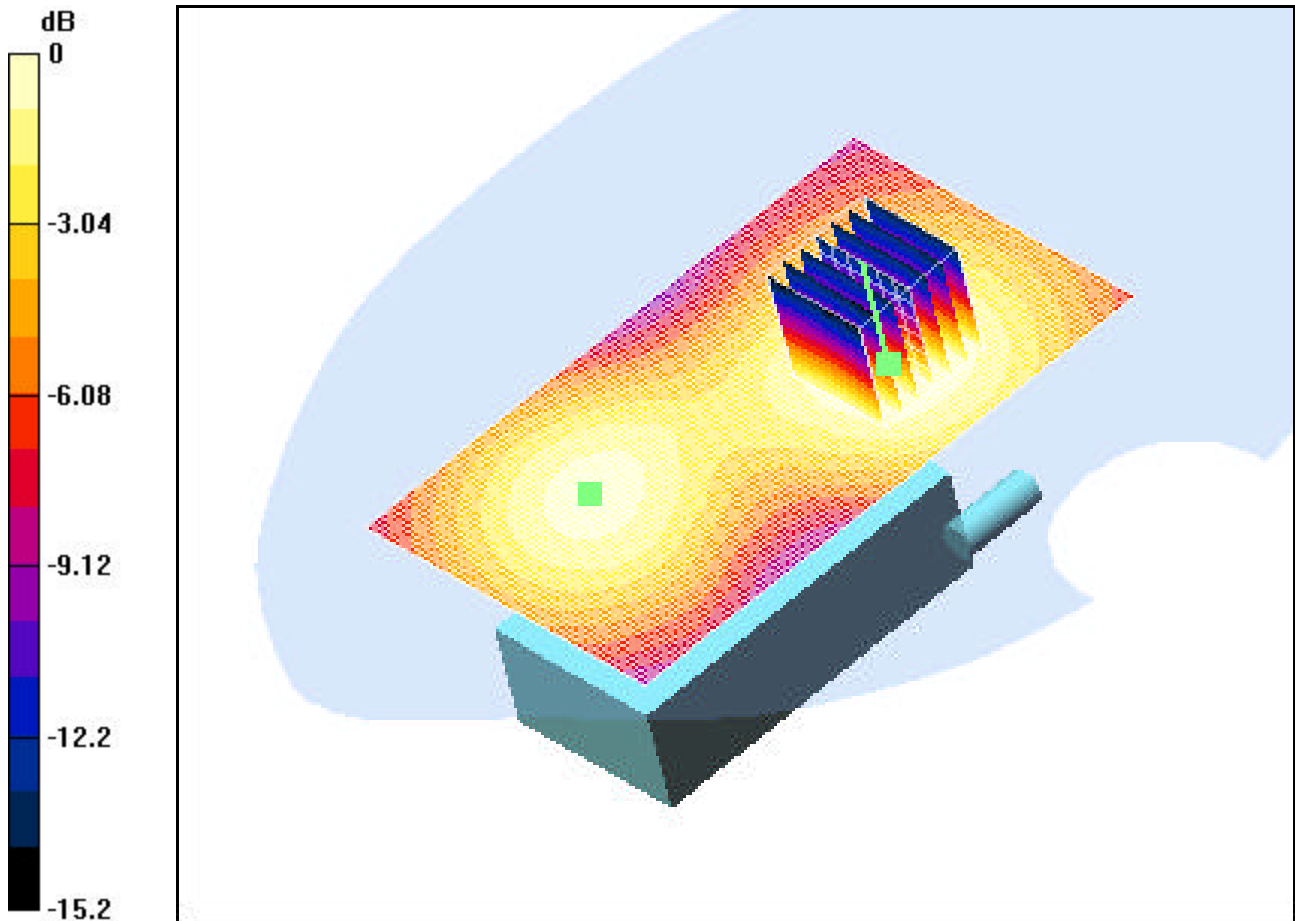

0 dB = 0.145mW/g

# PCTEST ENGINEERING LABORATORY, INC.

**DUT: SCP-7300; Type: SANYO Tri Mode Phone; Serial: FCC1**

Communication System: AMPS; Frequency: 836.49 MHz; Duty Cycle: 1:1

Medium: 835 Brain ( $\sigma = 0.9$  mho/m,  $\epsilon_r = 40.3$ ,  $\rho = 1000$  kg/m<sup>3</sup>)

Phantom section: Right Section

Test Date: 10-28-2003; Ambient Temp: 20.2°C; Tissue Temp: 18.2°C

Probe: ES3DV2 - SN3022; ConvF(6.1, 6.1, 6.1); Calibrated: 9/23/2003

Sensor-Surface: 4mm (Mechanical Surface Detection)

Electronics: DAE3 SN330; Calibrated: 12/1/2002

Phantom: SAM 12b; Type: SAM 4.0; Serial: TP:1197

Measurement SW: DAS4, V4.1 Build 47; Postprocessing SW: SEMCAD, V1.8 Build 62

## Ch.383, Touch, Ant Out, Standard Battery

**Area Scan (51x151x1):** Measurement grid: dx=15mm, dy=15mm

**Zoom Scan (7x7x7)/Cube 0:** Measurement grid: dx=5mm, dy=5mm, dz=5mm

Peak SAR (extrapolated) = 2.26 W/kg

SAR(1 g) = 1.32 mW/g; SAR(10 g) = 0.818 mW/g

Reference Value = 14.8 V/m

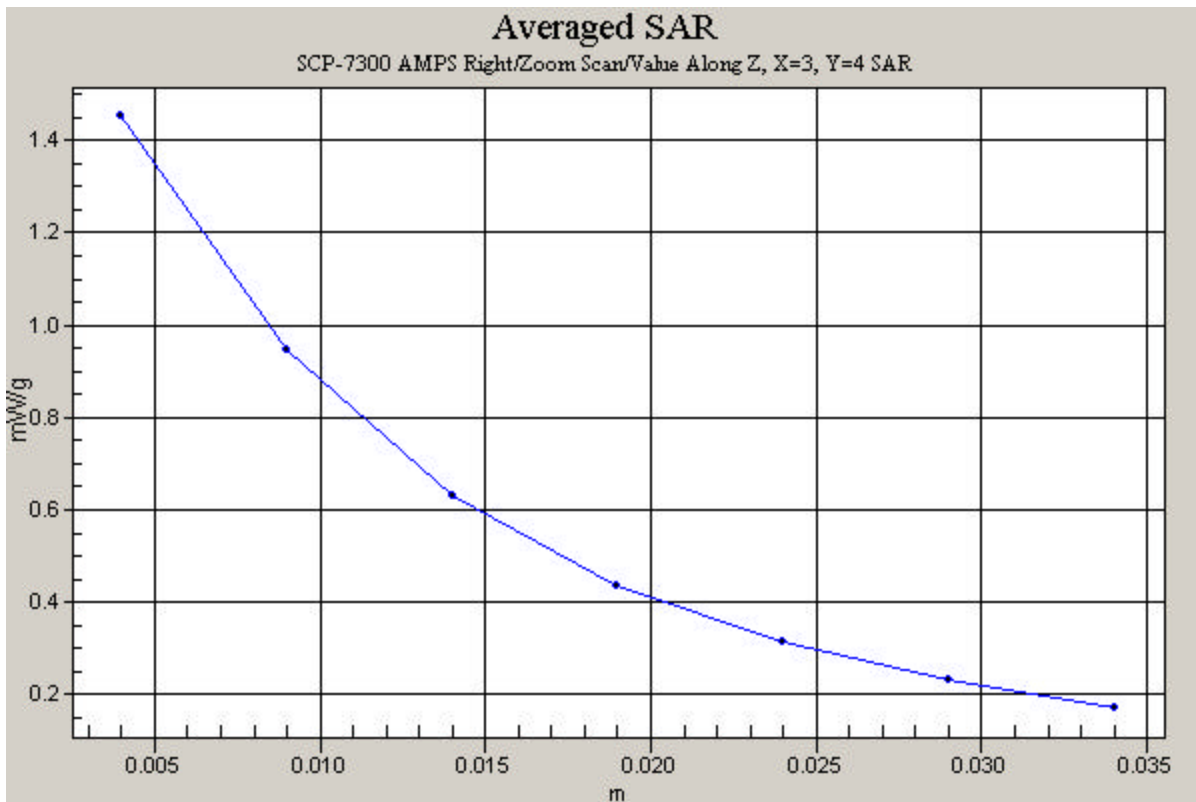

# PCTEST ENGINEERING LABORATORY, INC.

**DUT: SCP-7300; Type: SANYO Tri Mode Phone; Serial: FCC1**

Communication System: PCS CDMA; Frequency: 1851.25 MHz; Duty Cycle: 1:1

Medium: 1900 Brain ( $\sigma = 1.39$  mho/m,  $\epsilon_r = 41.02$ ,  $\rho = 1000$  kg/m<sup>3</sup>)

Phantom section: Right Section

Test Date: 10-27-2003; Ambient Temp: 22.8°C; Tissue Temp: 19.6°C

Probe: ES3DV2 - SN3022; ConvF(5, 5, 5); Calibrated: 9/23/2003

Sensor-Surface: 4mm (Mechanical Surface Detection)

Electronics: DAE3 SN330; Calibrated: 12/1/2002

Phantom: SAM 12b; Type: SAM 4.0; Serial: TP:1197

Measurement SW: DASYS4, V4.1 Build 47; Postprocessing SW: SEMCAD, V1.8 Build 62

## Ch.0025, Touch, Ant In, Standard Battery

**Area Scan (51x141x1):** Measurement grid: dx=15mm, dy=15mm

**Zoom Scan (7x7x7)/Cube 0:** Measurement grid: dx=5mm, dy=5mm, dz=5mm

Peak SAR (extrapolated) = 1.74 W/kg

SAR(1 g) = 0.973 mW/g; SAR(10 g) = 0.540 mW/g

Reference Value = 7.12 V/m

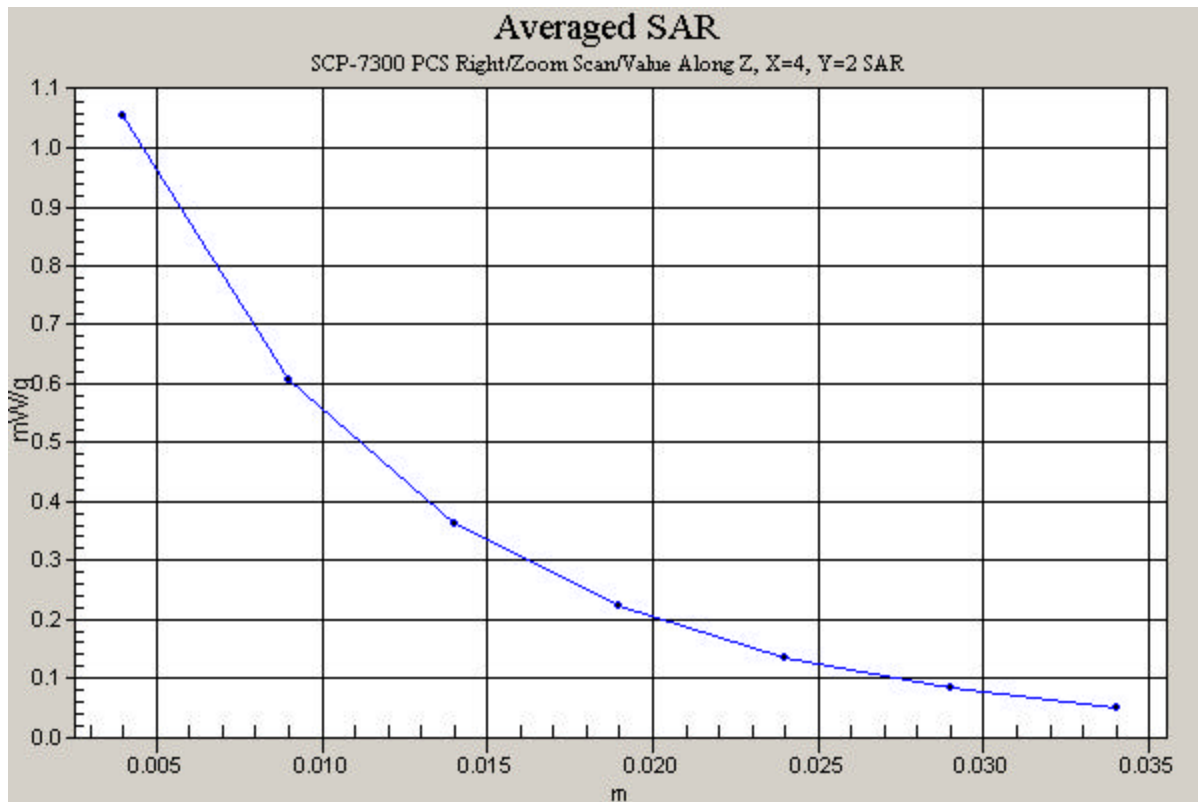

# PCTEST ENGINEERING LABORATORY, INC.

**DUT: SCP-7300; Type: SANYO Tri Mode Phone; Serial: FCC1**

Communication System: AMPS; Frequency: 836.49 MHz; Duty Cycle: 1:1

Medium: 835 Muscle ( $\sigma = 0.99$  mho/m,  $\epsilon_r = 53.23$ ,  $\rho = 1000$  kg/m<sup>3</sup>)

Phantom section: Flat Section; Space: 1.9 cm

Test Date: 10-30-2003; Ambient Temp: 21.8°C; Tissue Temp: 20.6°C

Probe: ES3DV2 - SN3022; ConvF(6, 6, 6); Calibrated: 9/23/2003

Sensor-Surface: 4mm (Mechanical Surface Detection)

Electronics: DAE3 SN330; Calibrated: 12/1/2002

Phantom: SAM 12b; Type: SAM 4.0; Serial: TP:1197

Measurement SW: DASY4, V4.1 Build 47; Postprocessing SW: SEMCAD, V1.8 Build 62

## Ch.383, Ant Out, Standard Battery

**Area Scan (51x141x1):** Measurement grid: dx=15mm, dy=15mm

**Zoom Scan (7x7x7)/Cube 0:** Measurement grid: dx=5mm, dy=5mm, dz=5mm

Peak SAR (extrapolated) = 1.49 W/kg

SAR(1 g) = 1.08 mW/g; SAR(10 g) = 0.750 mW/g

Reference Value = 27 V/m

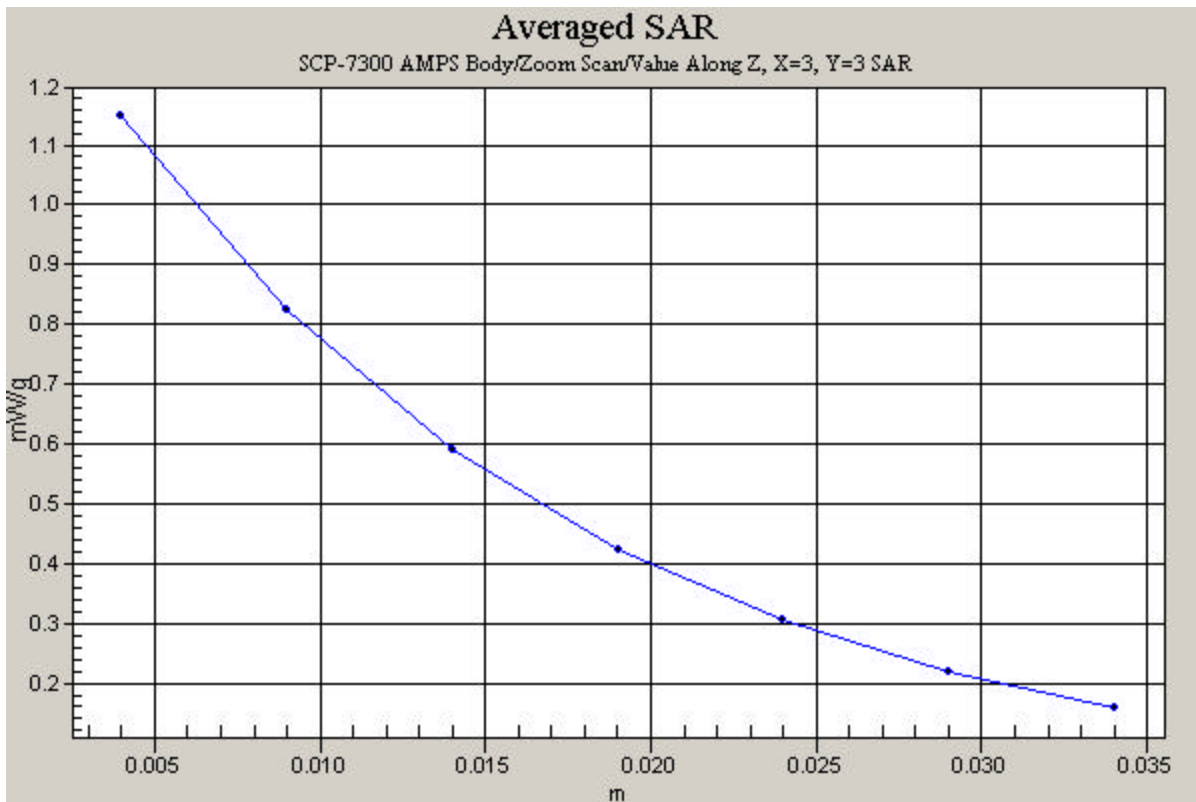

# PCTEST ENGINEERING LABORATORY, INC.

**DUT: SCP-7300; Type: SANYO Tri Mode Phone; Serial: FCC1**

Communication System: PCS CDMA; Frequency: 1880 MHz; Duty Cycle: 1:1

Medium: 1900 Muscle ( $\sigma = 1.58$  mho/m,  $\epsilon_r = 50.02$ ,  $\rho = 1000$  kg/m<sup>3</sup>)

Phantom section: Flat Section; Space: 1.9 cm

Test Date: 10-28-2003; Ambient Temp: 22.7°C; Tissue Temp: 21.1°C

Probe: ES3DV2 - SN3022; ConvF(4.5, 4.5, 4.5); Calibrated: 9/23/2003

Sensor-Surface: 4mm (Mechanical Surface Detection)

Electronics: DAE3 SN330; Calibrated: 12/1/2002

Phantom: SAM 12b; Type: SAM 4.0; Serial: TP:1197

Measurement SW: DASY4, V4.1 Build 47; Postprocessing SW: SEMCAD, V1.8 Build 62

## Ch.0600, Ant In, Standard Battery

**Area Scan (51x91x1):** Measurement grid: dx=15mm, dy=15mm

**Zoom Scan (7x7x7)/Cube 0:** Measurement grid: dx=5mm, dy=5mm, dz=5mm

Peak SAR (extrapolated) = 1.17 W/kg

SAR(1 g) = 0.673 mW/g; SAR(10 g) = 0.370 mW/g

Reference Value = 16.5 V/m

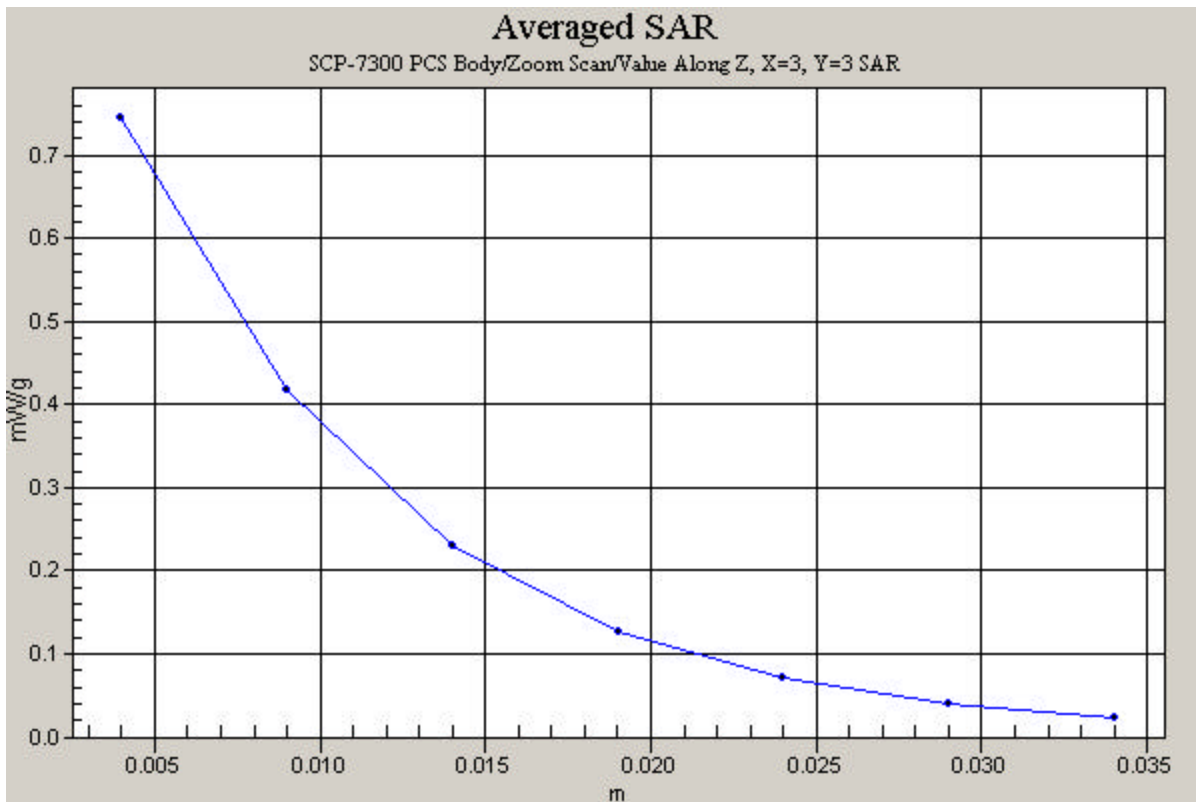

## **APPENDIX B: DIPOLE VALIDATION**

# PCTEST ENGINEERING LABORATORY, INC.

**DUT: Dipole 835 MHz; Type: D835V2; Serial: 406**

Communication System: CW; Frequency: 835 MHz; Duty Cycle: 1:1

Medium: 835 Brain ( $\sigma = 0.9$  mho/m,  $\epsilon_r = 40.3$ ,  $\rho = 1000$  kg/m<sup>3</sup>)

Phantom section: Flat Section; Space: 15 mm

Test Date: 10-28-2003; Ambient Temp: 20.2°C; Tissue Temp: 18.2°C

Probe: ES3DV2 - SN3022; ConvF(6.1, 6.1, 6.1); Calibrated: 9/23/2003

Sensor-Surface: 3mm (Mechanical Surface Detection)

Electronics: DAE3 SN330; Calibrated: 12/1/2002

Phantom: SAM 12b; Type: SAM 4.0; Serial: TP:1197

Measurement SW: DASY4, V4.1 Build 47; Postprocessing SW: SEMCAD, V1.8 Build 62

## 835 MHz Dipole Validation

**Area Scan (61x121x1):** Measurement grid: dx=15mm, dy=15mm

**Zoom Scan (7x7x7)/Cube 0:** Measurement grid: dx=5mm, dy=5mm, dz=5mm

Input Power = 24.0 dBm (250mW)

SAR(1 g) = 2.4 mW/g; SAR(10 g) = 1.56 mW/g

Target SAR(1g) = 2.375 mW/g; Deviation = +1.1 %

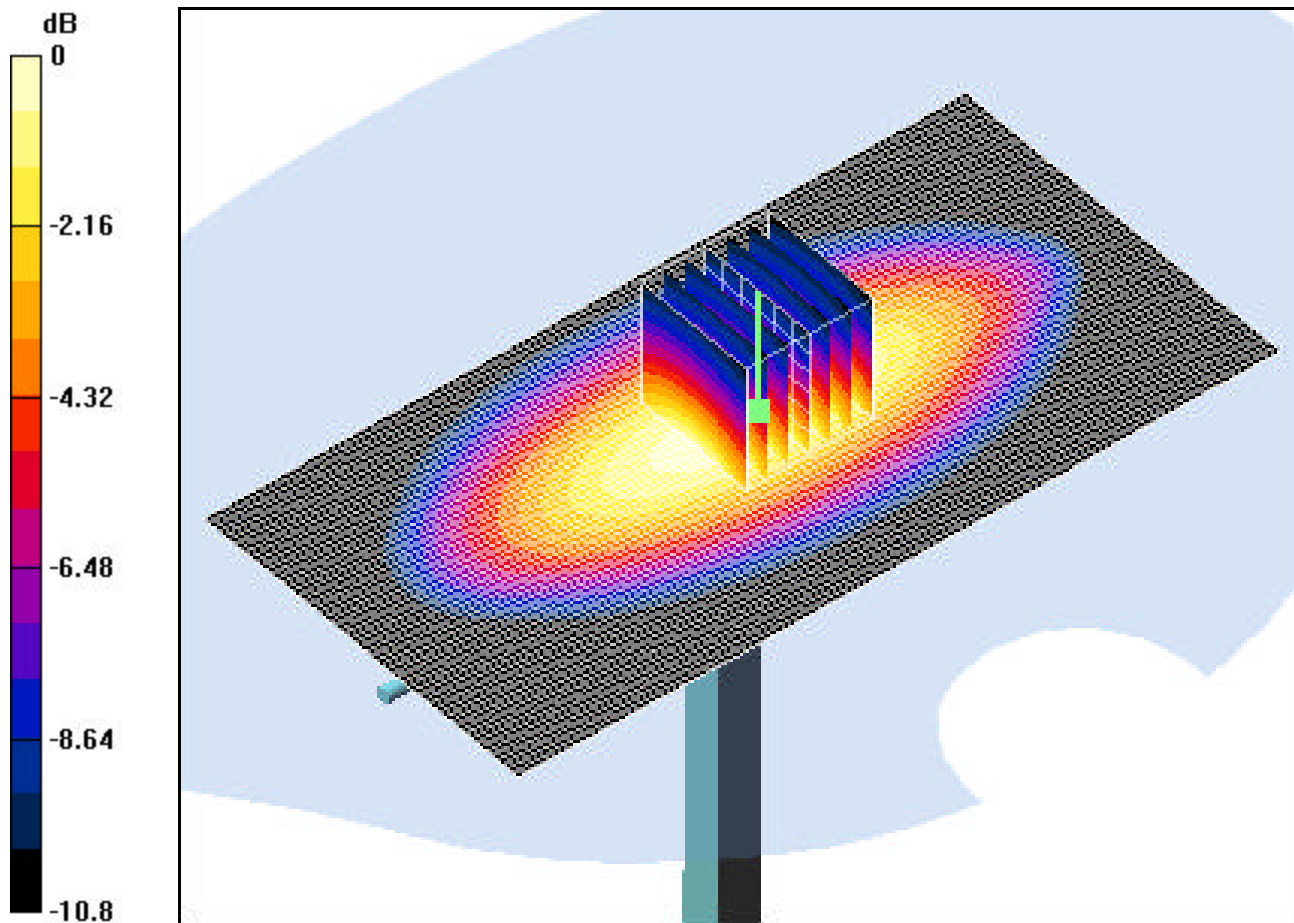

0 dB = 2.83mW/g



# PCTEST ENGINEERING LABORATORY, INC.

**DUT: Dipole 1900 MHz; Type: D1900V2; Serial: 502**

Communication System: CW; Frequency: 1900 MHz; Duty Cycle: 1:1

Medium: 1900 Brain ( $\sigma = 1.39$  mho/m,  $\epsilon_r = 41.02$ ,  $\rho = 1000$  kg/m<sup>3</sup>)

Phantom section: Flat Section; Space: 10 mm

Test Date: 10-27-2003; Ambient Temp: 22.8°C; Tissue Temp: 19.6°C

Probe: ES3DV2 - SN3022; ConvF(5, 5, 5); Calibrated: 9/23/2003

Sensor-Surface: 3mm (Mechanical Surface Detection)

Electronics: DAE3 SN330; Calibrated: 12/1/2002

Phantom: SAM 12b; Type: SAM 4.0; Serial: TP:1197

Measurement SW: DASY4, V4.1 Build 47; Postprocessing SW: SEMCAD, V1.8 Build 62

## 1900 MHz Dipole Validation

**Area Scan (41x51x1):** Measurement grid: dx=15mm, dy=15mm

**Zoom Scan (7x7x7)/Cube 0:** Measurement grid: dx=5mm, dy=5mm, dz=5mm

Input Power = 20 dBm (100mW)

SAR(1 g) = 3.74 mW/g; SAR(10 g) = 1.87 mW/g

Target SAR(1g) = 3.97 mW/g; Deviation = -5.8 %

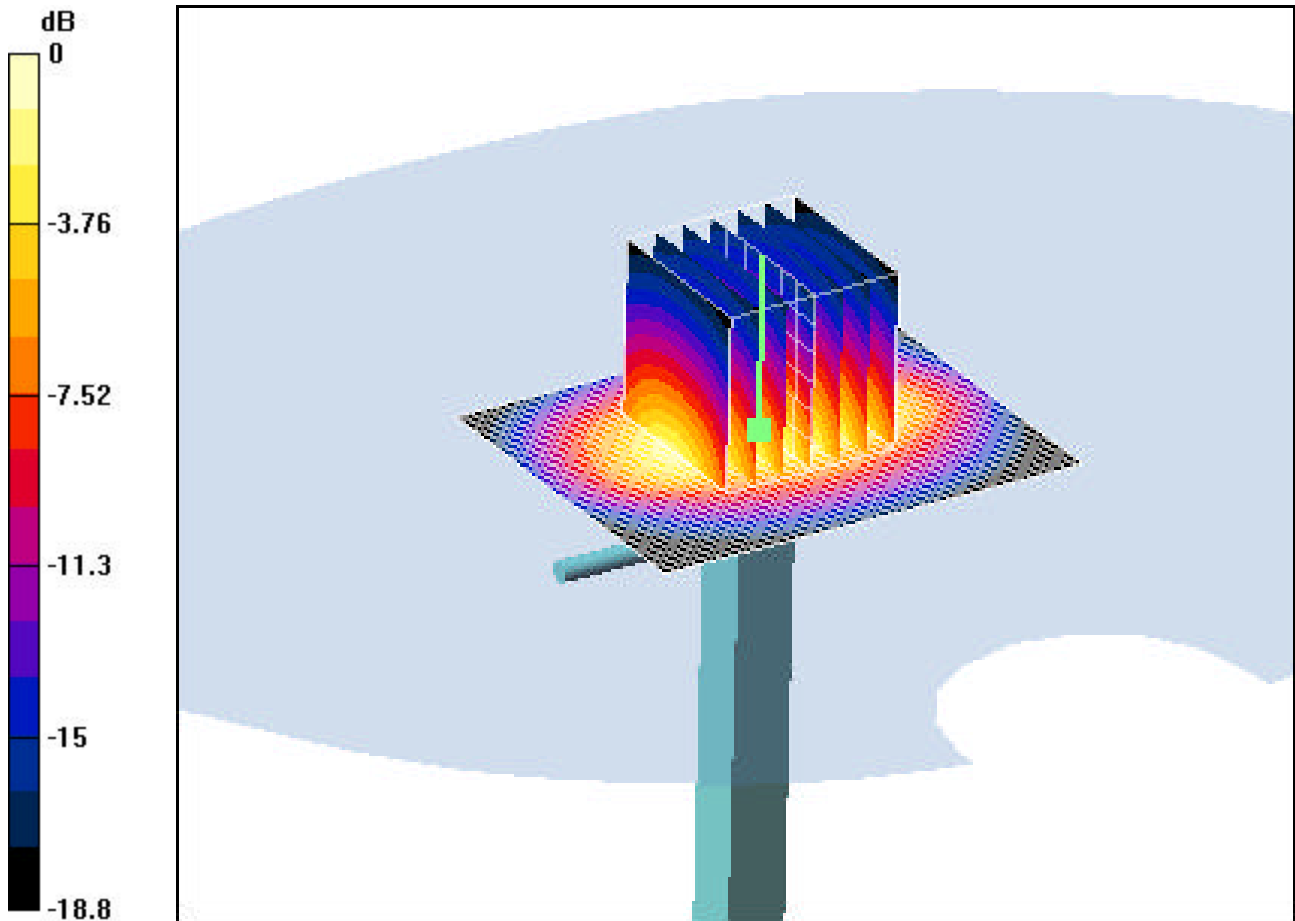

0 dB = 4.88mW/g

## **APPENDIX C: PROBE CALIBRATION**

Client **PC Test**

**CALIBRATION CERTIFICATE**

Object(s) **ES3DV2 - SN:3022**  
 Calibration procedure(s) **QA CAL-01 v2  
Calibration procedure for dosimetric E-field probes**  
 Calibration date: **September 23, 2003**  
 Condition of the calibrated item **In Tolerance (according to the specific calibration document)**

This calibration statement documents traceability of M&TE used in the calibration procedures and conformity of the procedures with the ISO/IEC 17025 international standard.

All calibrations have been conducted in the closed laboratory facility: environment temperature 22 +/- 2 degrees Celsius and humidity < 75%.

Calibration Equipment used (M&TE critical for calibration)

Model Type	ID #	Cal Date (Calibrated by, Certificate No.)	Scheduled Calibration
Power meter EPM E4419B	GB41293874	2-Apr-03 (METAS, No 252-0250)	Apr-04
Power sensor E4412A	MY41495277	2-Apr-03 (METAS, No 252-0250)	Apr-04
Reference 20 dB Attenuator	SN: 5086 (20b)	3-Apr-03 (METAS No. 251-0340)	Apr-04
Fluke Process Calibrator Type 702	SN: 6295803	8-Sep-03 (Sintrel SCS No. E-030020)	Sep-04
Power sensor HP 8481A	MY41092180	18-Sep-02 (Agilent, No. 20020918)	In house check: Oct 03
RF generator HP 8684C	US3642U01700	4-Aug-99 (SPEAG, in house check Aug-02)	In house check: Aug-05
Network Analyzer HP 8753E	US37390585	18-Oct-01 (Agilent, No. 24BR1033101)	In house check: Oct 03

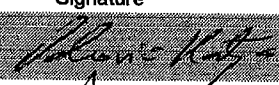
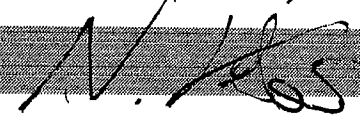
	Name	Function	Signature
Calibrated by:	Katja Pokovic	Laboratory Director	
Approved by:	Niels Kuster	Quality Manager	

Date issued: October 5, 2003

This calibration certificate is issued as an intermediate solution until the accreditation process (based on ISO/IEC 17025 International Standard) for Calibration Laboratory of Schmid & Partner Engineering AG is completed.

# Probe ES3DV2

**SN:3022**

Manufactured: April 15, 2003  
Last calibration: September 23, 2003

**Calibrated for DASY Systems**

(Note: non-compatible with DASY2 system!)

# DASY - Parameters of Probe: ES3DV2 SN:3022

## Sensitivity in Free Space

NormX	<b>1.00</b> $\mu\text{V}/(\text{V}/\text{m})^2$
NormY	<b>1.04</b> $\mu\text{V}/(\text{V}/\text{m})^2$
NormZ	<b>0.98</b> $\mu\text{V}/(\text{V}/\text{m})^2$

## Diode Compression

DCP X	<b>95</b>	mV
DCP Y	<b>95</b>	mV
DCP Z	<b>95</b>	mV

## Sensitivity in Tissue Simulating Liquid

**Head**                      **900 MHz**                       $\epsilon_r = 41.5 \pm 5\%$                        $\sigma = 0.97 \pm 5\%$  mho/m  
 Valid for f=800-1000 MHz with Head Tissue Simulating Liquid according to EN 50361, P1528-200X

ConvF X	<b>6.1</b> $\pm 9.5\%$ (k=2)	Boundary effect:
ConvF Y	<b>6.1</b> $\pm 9.5\%$ (k=2)	Alpha <b>0.32</b>
ConvF Z	<b>6.1</b> $\pm 9.5\%$ (k=2)	Depth <b>1.65</b>

**Head**                      **1800 MHz**                       $\epsilon_r = 40.0 \pm 5\%$                        $\sigma = 1.40 \pm 5\%$  mho/m  
 Valid for f=1710-1910 MHz with Head Tissue Simulating Liquid according to EN 50361, P1528-200X

ConvF X	<b>5.0</b> $\pm 9.5\%$ (k=2)	Boundary effect:
ConvF Y	<b>5.0</b> $\pm 9.5\%$ (k=2)	Alpha <b>0.25</b>
ConvF Z	<b>5.0</b> $\pm 9.5\%$ (k=2)	Depth <b>2.30</b>

## Boundary Effect

**Head**                      **900 MHz**                      Typical SAR gradient: 5 % per mm

Probe Tip to Boundary		<b>1 mm</b>	<b>2 mm</b>
SAR <sub>be</sub> [%] Without Correction Algorithm		5.5	2.5
SAR <sub>be</sub> [%] With Correction Algorithm		0.1	0.4

**Head**                      **1800 MHz**                      Typical SAR gradient: 10 % per mm

Probe Tip to Boundary		<b>1 mm</b>	<b>2 mm</b>
SAR <sub>be</sub> [%] Without Correction Algorithm		7.1	4.4
SAR <sub>be</sub> [%] With Correction Algorithm		0.0	0.1

## Sensor Offset

Probe Tip to Sensor Center	<b>2.0</b>	mm
----------------------------	------------	----

### Receiving Pattern ( $\phi$ , $\theta = 0^\circ$ )

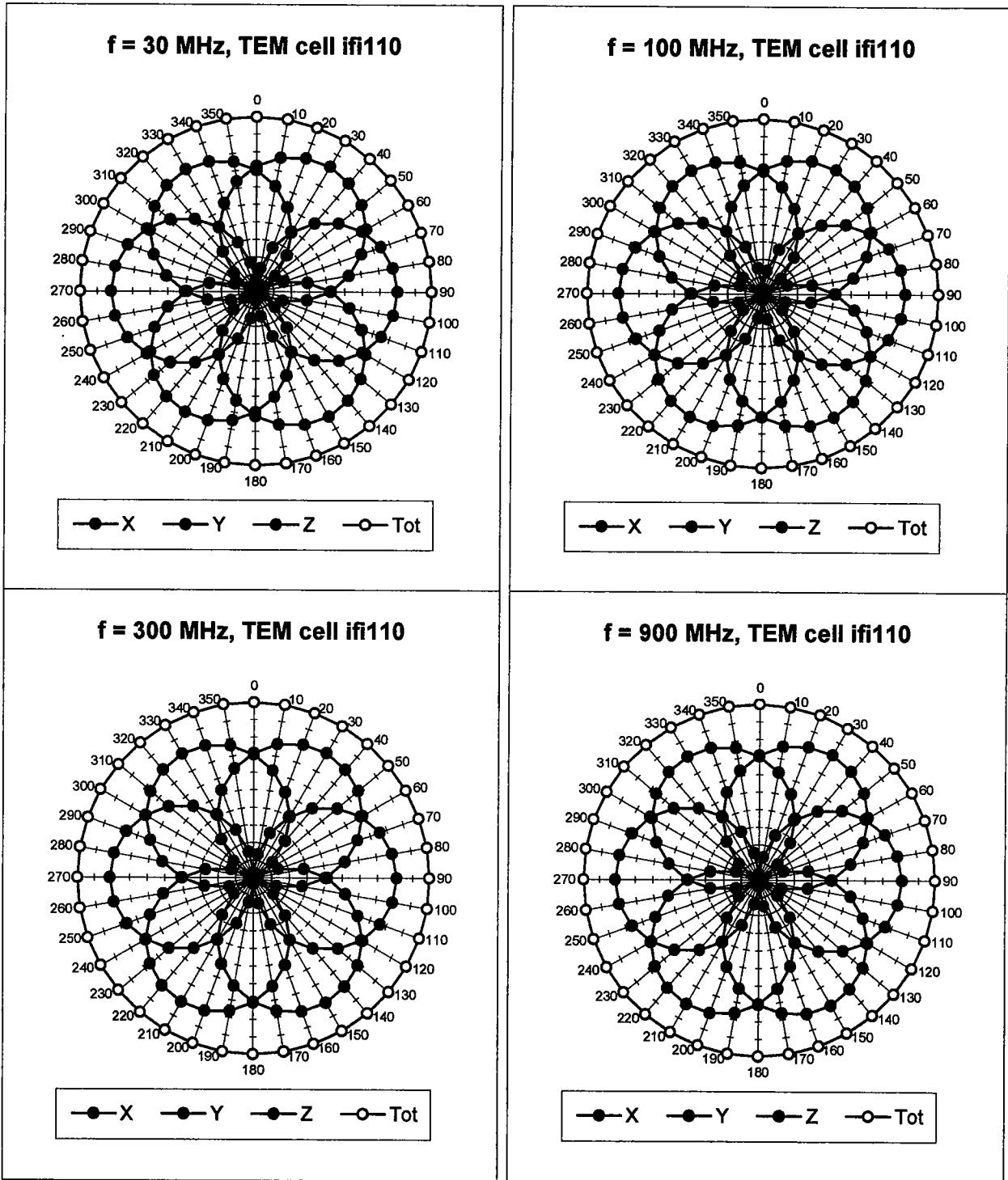

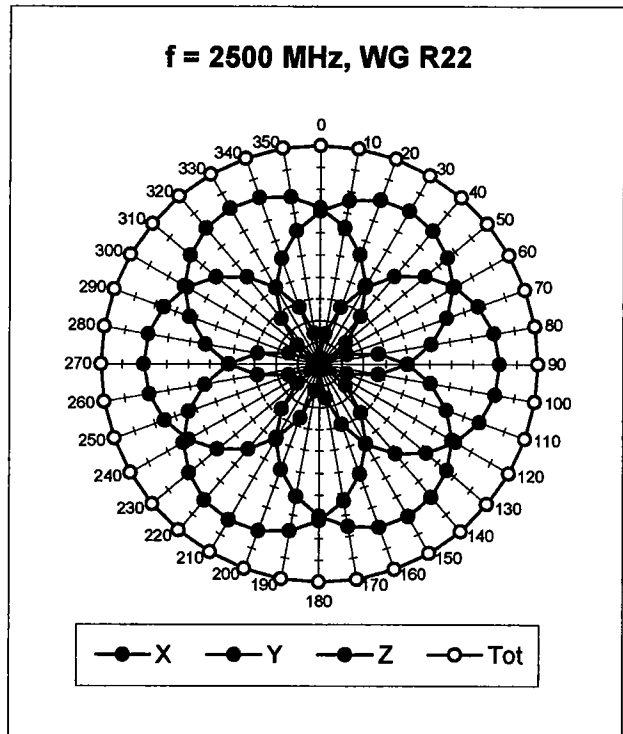
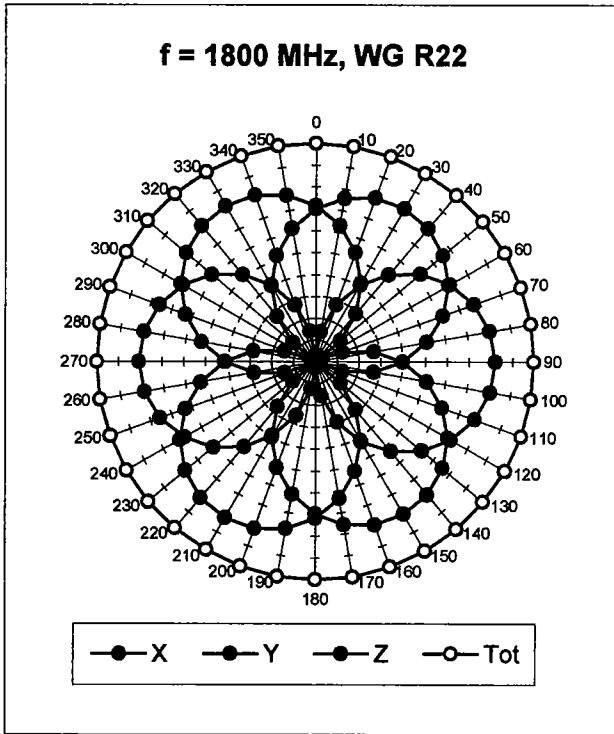

### Isotropy Error ( $\phi$ ), $\theta = 0^\circ$

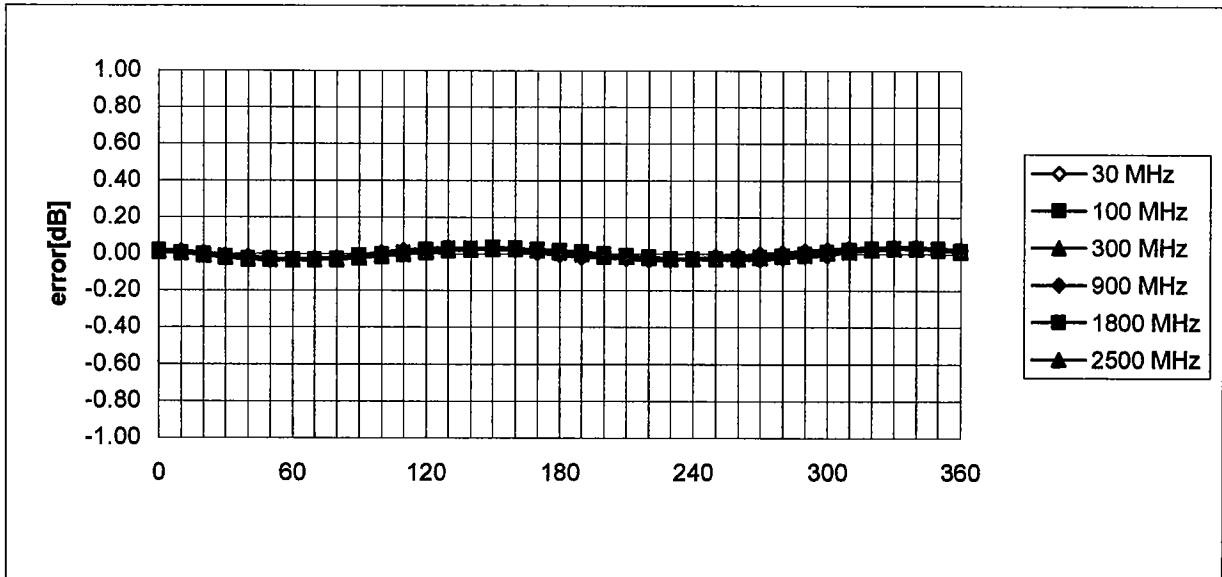

# Frequency Response of E-Field

( TEM-Cell:ifi110, Waveguide R22)

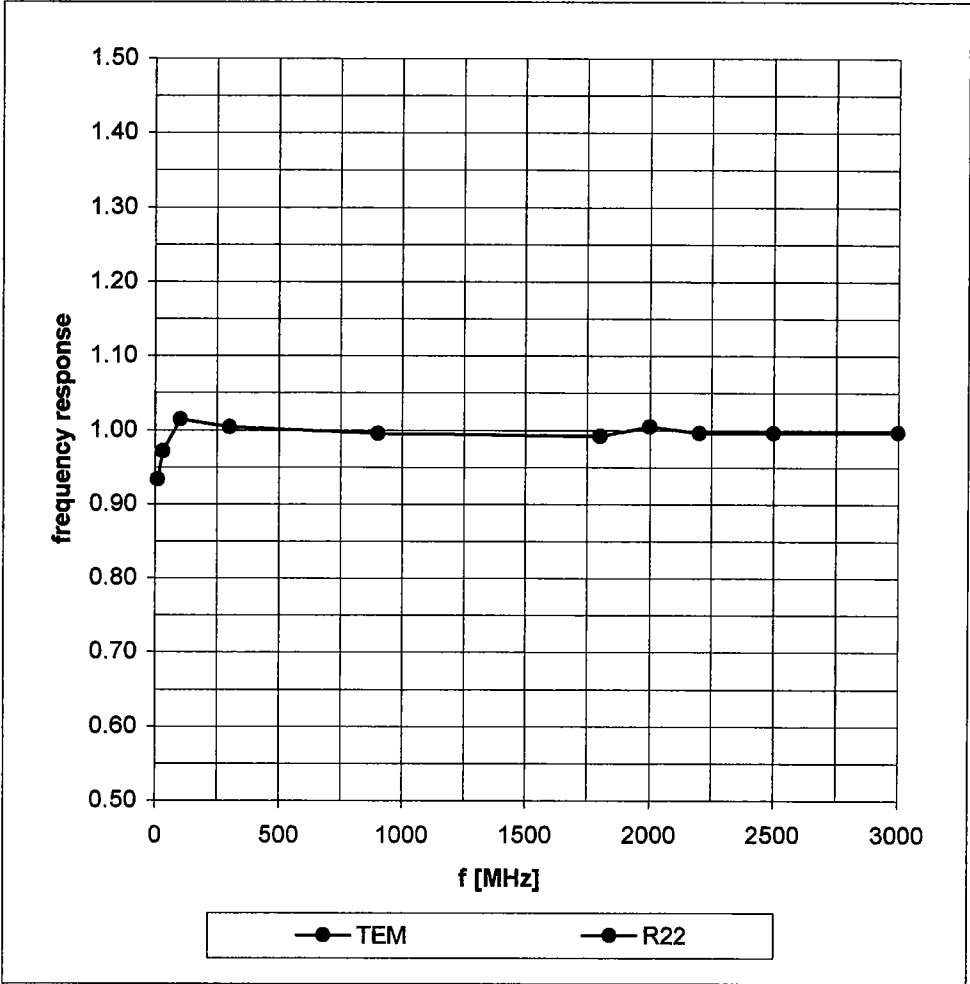



## Dynamic Range $f(\text{SAR}_{\text{brain}})$ ( Waveguide R22 )

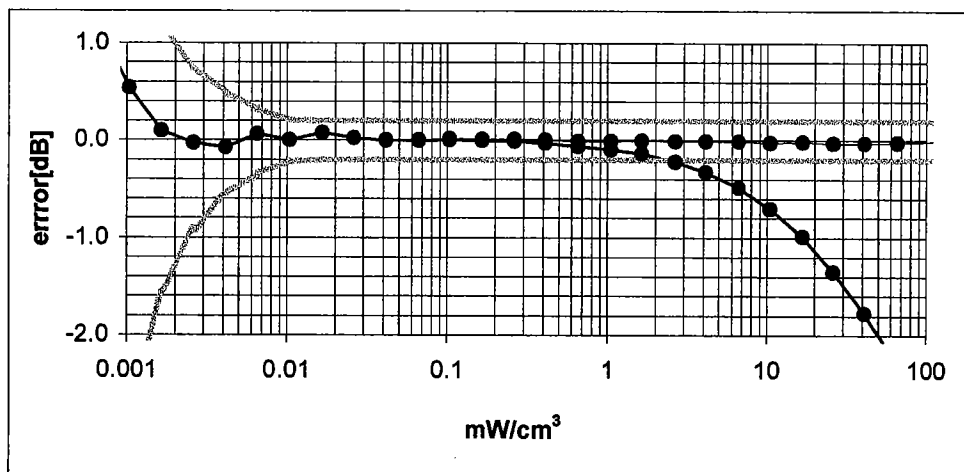
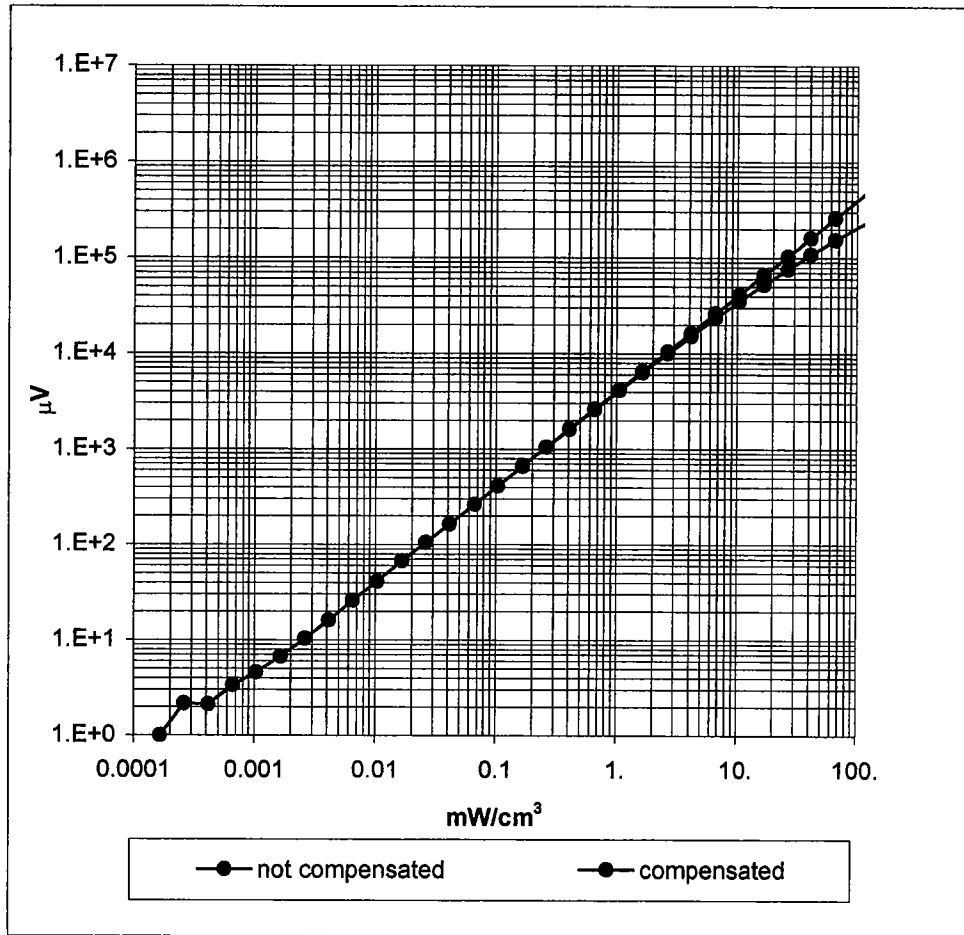

## Conversion Factor Assessment

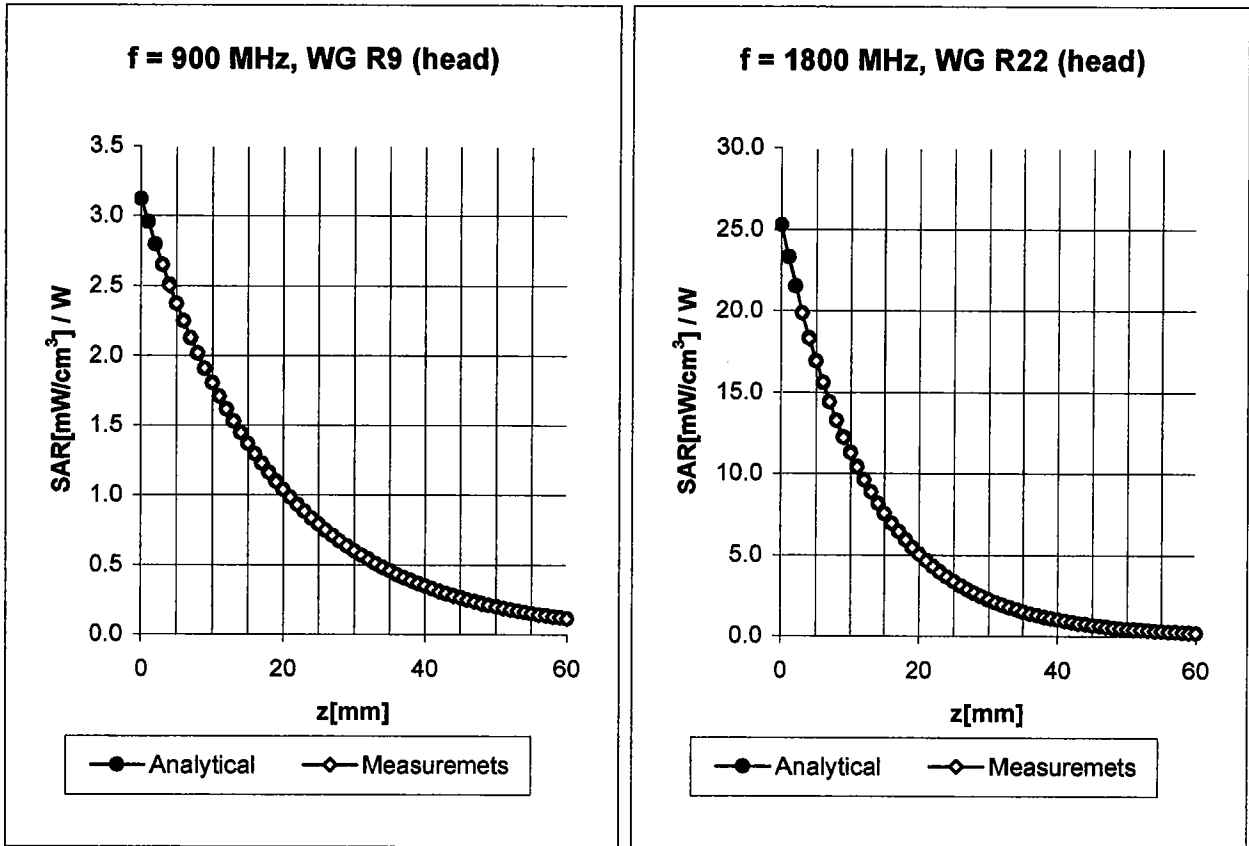

**Head                      900 MHz                       $\epsilon_r = 41.5 \pm 5\%$                        $\sigma = 0.97 \pm 5\%$  mho/m**

**Valid for f=800-1000 MHz with Head Tissue Simulating Liquid according to EN 50361, P1528-200X**

ConvF X	<b>6.1</b> $\pm 9.5\%$ (k=2)	Boundary effect:
ConvF Y	<b>6.1</b> $\pm 9.5\%$ (k=2)	Alpha <b>0.32</b>
ConvF Z	<b>6.1</b> $\pm 9.5\%$ (k=2)	Depth <b>1.65</b>

**Head                      1800 MHz                       $\epsilon_r = 40.0 \pm 5\%$                        $\sigma = 1.40 \pm 5\%$  mho/m**

**Valid for f=1710-1910 MHz with Head Tissue Simulating Liquid according to EN 50361, P1528-200X**

ConvF X	<b>5.0</b> $\pm 9.5\%$ (k=2)	Boundary effect:
ConvF Y	<b>5.0</b> $\pm 9.5\%$ (k=2)	Alpha <b>0.25</b>
ConvF Z	<b>5.0</b> $\pm 9.5\%$ (k=2)	Depth <b>2.30</b>

## Conversion Factor Assessment

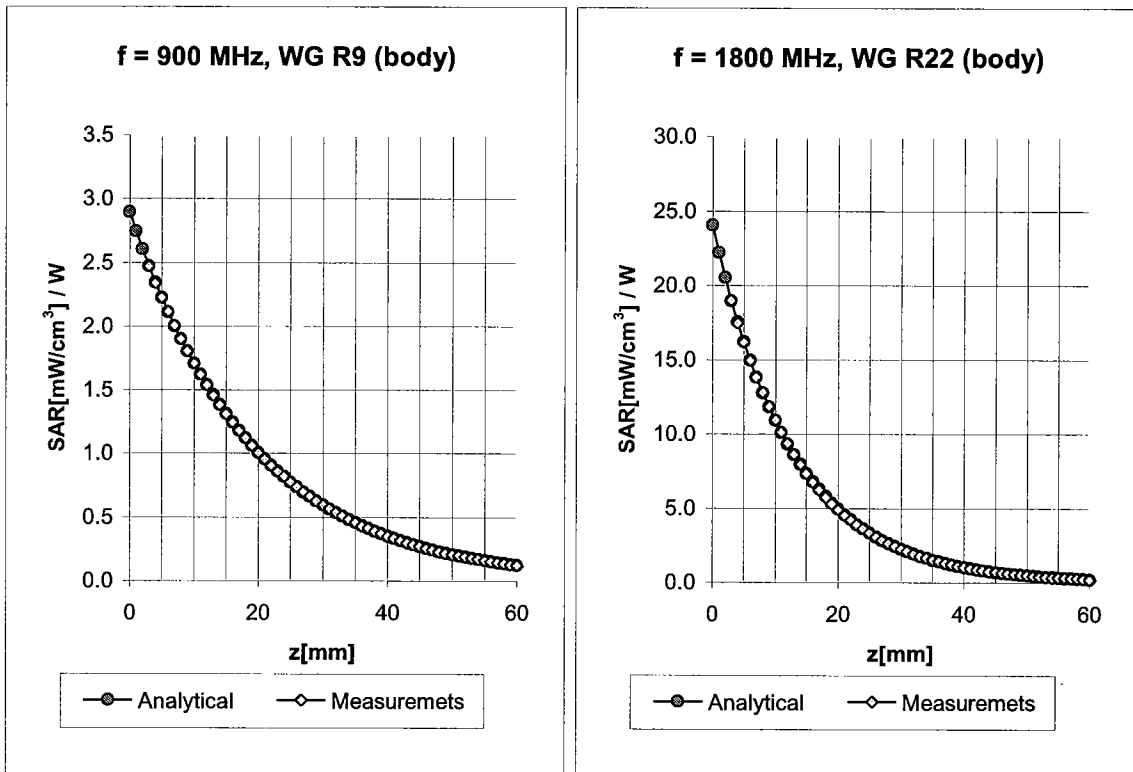

**Body**                      **900 MHz**                       $\epsilon_r = 55.0 \pm 5\%$                        $\sigma = 1.05 \pm 5\%$  mho/m

Valid for f=800-1000 MHz with Body Tissue Simulating Liquid according to OET 65 Suppl. C

ConvF X	6.0 ± 9.5% (k=2)	Boundary effect:
ConvF Y	6.0 ± 9.5% (k=2)	Alpha <b>0.38</b>
ConvF Z	6.0 ± 9.5% (k=2)	Depth <b>1.47</b>

**Body**                      **1800 MHz**                       $\epsilon_r = 53.3 \pm 5\%$                        $\sigma = 1.52 \pm 5\%$  mho/m

Valid for f=1710-1910 MHz with Body Tissue Simulating Liquid according to OET 65 Suppl. C

ConvF X	4.5 ± 9.5% (k=2)	Boundary effect:
ConvF Y	4.5 ± 9.5% (k=2)	Alpha <b>0.22</b>
ConvF Z	4.5 ± 9.5% (k=2)	Depth <b>3.42</b>

## Conversion Factor Assessment

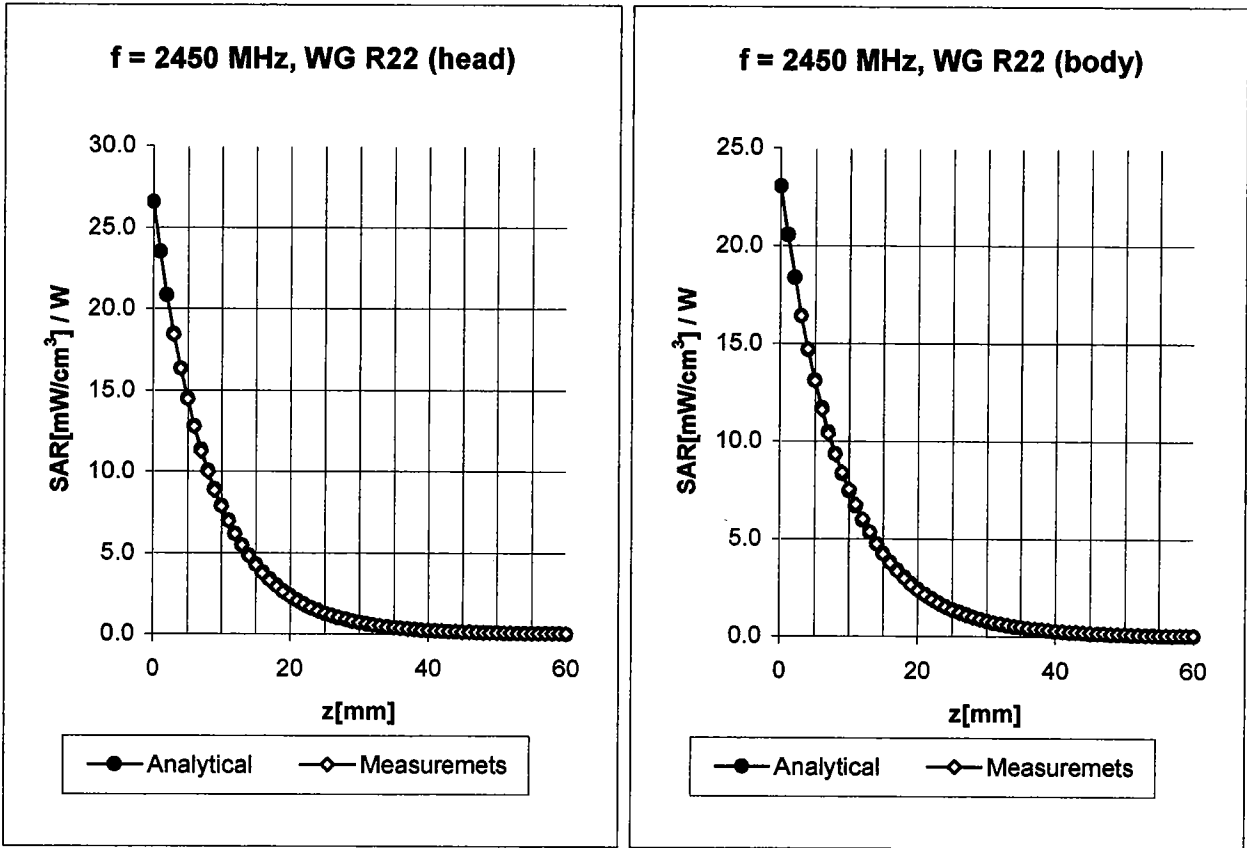

**Head                      2450 MHz                       $\epsilon_r = 39.2 \pm 5\%$                        $\sigma = 1.80 \pm 5\%$  mho/m**

**Valid for f=2400-2500 MHz with Head Tissue Simulating Liquid according to EN 50361, P1528-200X**

ConvF X	<b>4.5</b> $\pm 9.5\%$ (k=2)	Boundary effect:	
ConvF Y	<b>4.5</b> $\pm 9.5\%$ (k=2)	Alpha	<b>0.42</b>
ConvF Z	<b>4.5</b> $\pm 9.5\%$ (k=2)	Depth	<b>1.56</b>

**Body                      2450 MHz                       $\epsilon_r = 52.7 \pm 5\%$                        $\sigma = 1.95 \pm 5\%$  mho/m**

**Valid for f=2400-2500 MHz with Body Tissue Simulating Liquid according to OET 65 Suppl. C**

ConvF X	<b>4.2</b> $\pm 9.5\%$ (k=2)	Boundary effect:	
ConvF Y	<b>4.2</b> $\pm 9.5\%$ (k=2)	Alpha	<b>0.42</b>
ConvF Z	<b>4.2</b> $\pm 9.5\%$ (k=2)	Depth	<b>1.65</b>

## Conversion Factor Assessment

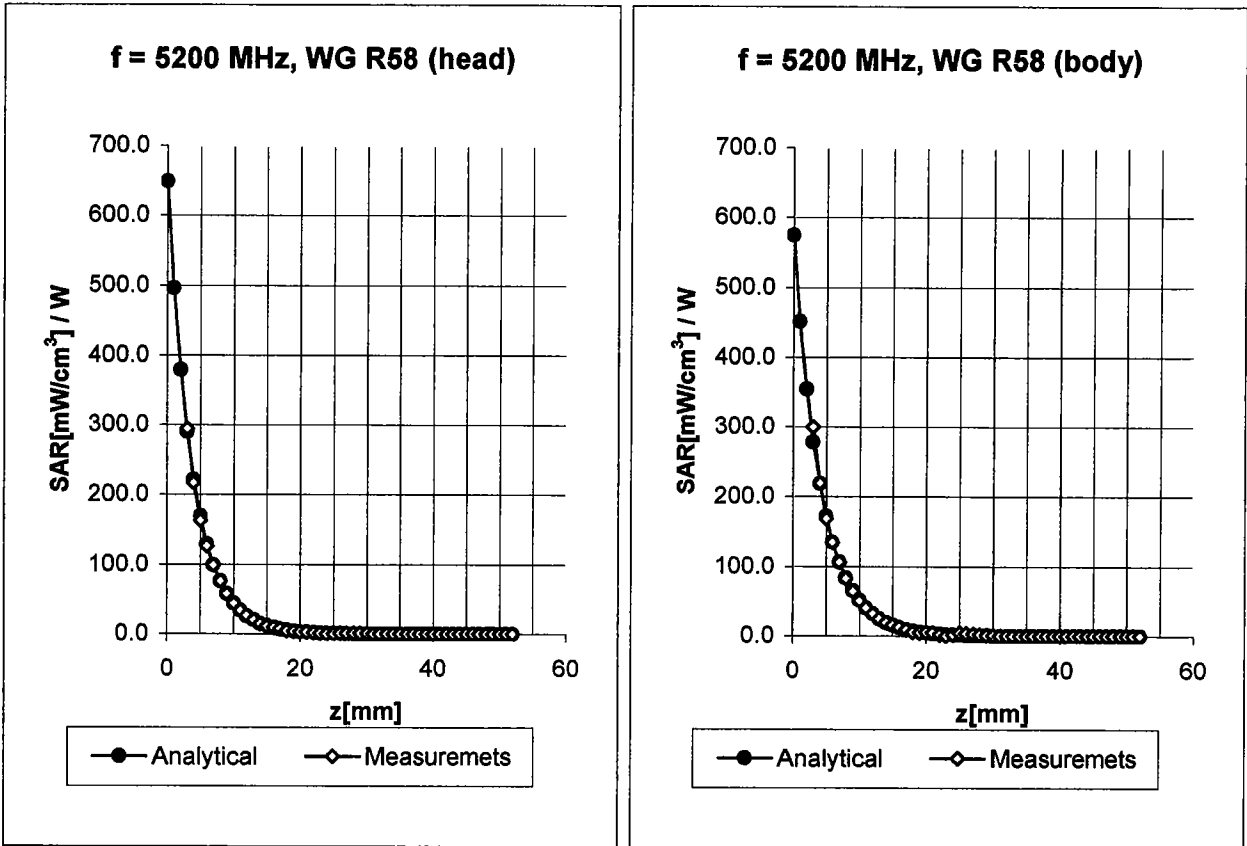

**Head                      5200 MHz                       $\epsilon_r = 36.0 \pm 5\%$                        $\sigma = 4.66 \pm 5\%$  mho/m**

**Valid for f=4940-5460 MHz with Head Tissue Simulating Liquid according to OET65-SuppC**

ConvF X	<b>2.60</b> $\pm 16.6\%$ (k=2)	Boundary effect:
ConvF Y	<b>2.60</b> $\pm 16.6\%$ (k=2)	Alpha <b>0.93</b>
ConvF Z	<b>2.60</b> $\pm 16.6\%$ (k=2)	Depth <b>1.50</b>

**Body                      5200 MHz                       $\epsilon_r = 49.0 \pm 5\%$                        $\sigma = 5.30 \pm 5\%$  mho/m**

**Valid for f=4940-5460 MHz with Body Tissue Simulating Liquid according to OET65-SuppC**

ConvF X	<b>1.80</b> $\pm 16.6\%$ (k=2)	Boundary effect:
ConvF Y	<b>1.80</b> $\pm 16.6\%$ (k=2)	Alpha <b>1.05</b>
ConvF Z	<b>1.80</b> $\pm 16.6\%$ (k=2)	Depth <b>1.60</b>

## Conversion Factor Assessment

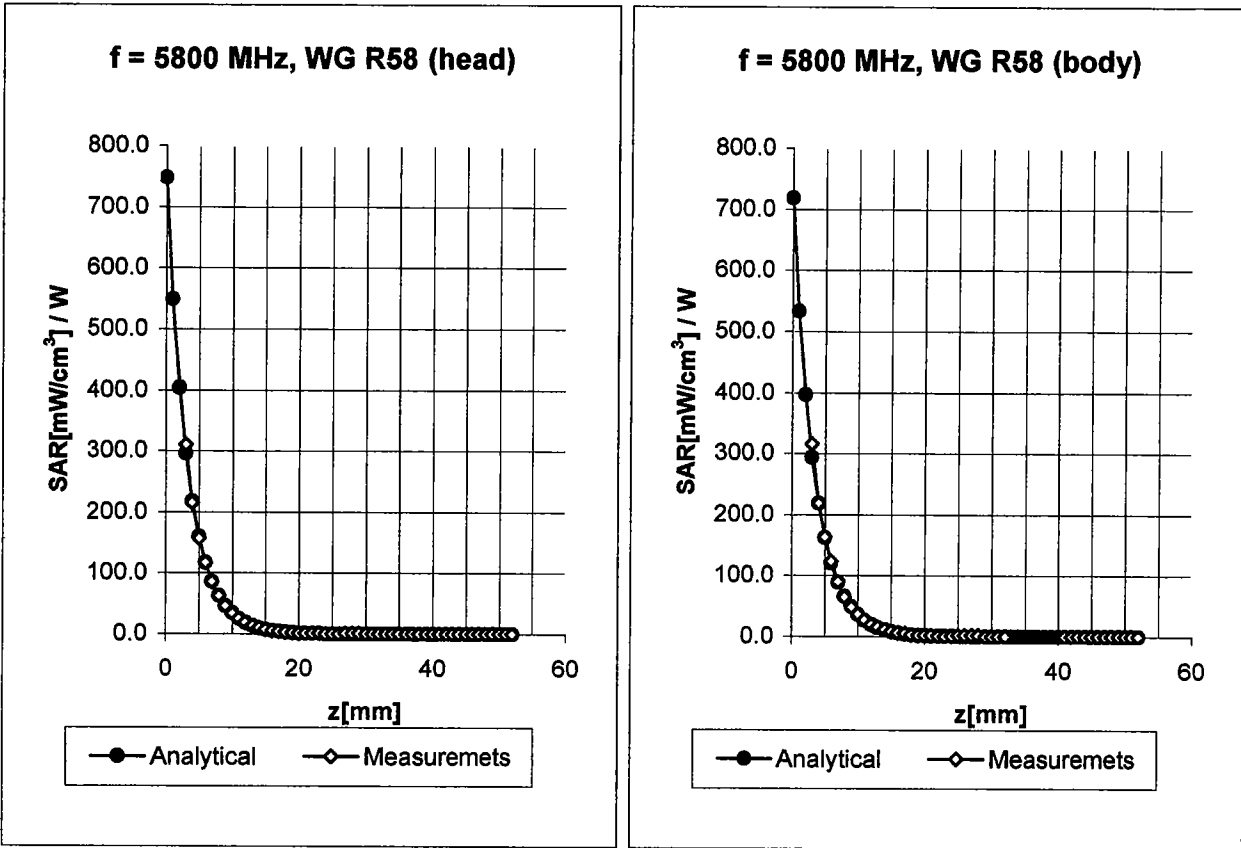

**Head                      5800 MHz                       $\epsilon_r = 35.3 \pm 5\%$                        $\sigma = 5.27 \pm 5\%$  mho/m**

**Valid for f=5510-6090 MHz with Head Tissue Simulating Liquid according to OET65-SuppC**

ConvF X	<b>2.15</b> $\pm 16.6\%$ (k=2)	Boundary effect:
ConvF Y	<b>2.15</b> $\pm 16.6\%$ (k=2)	Alpha <b>1.04</b>
ConvF Z	<b>2.15</b> $\pm 16.6\%$ (k=2)	Depth <b>1.50</b>

**Body                      5800 MHz                       $\epsilon_r = 48.2 \pm 5\%$                        $\sigma = 6.0 \pm 5\%$  mho/m**

**Valid for f=5510-6090 MHz with Body Tissue Simulating Liquid according to OET65-SuppC**

ConvF X	<b>1.57</b> $\pm 16.6\%$ (k=2)	Boundary effect:
ConvF Y	<b>1.57</b> $\pm 16.6\%$ (k=2)	Alpha <b>1.15</b>
ConvF Z	<b>1.57</b> $\pm 16.6\%$ (k=2)	Depth <b>1.70</b>

# Deviation from Isotropy in HSL

Error ( $\theta\phi$ ),  $f = 900$  MHz

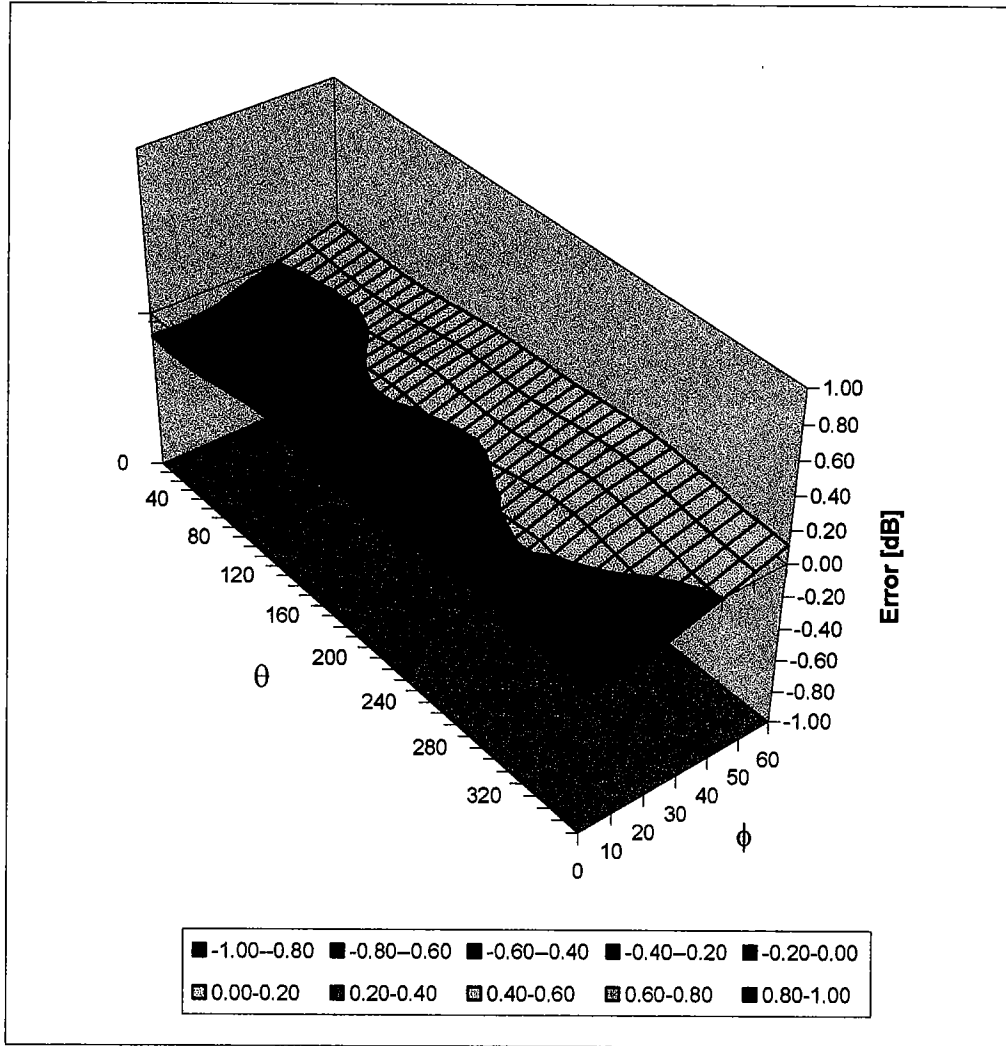

## **Additional Conversion Factors**

**for Dosimetric E-Field Probe**

Type:

**ES3DV2**

Serial Number:

**3022**

Place of Assessment:

**Zurich**

Date of Assessment:

**December 3, 2003**

Probe Calibration Date:

**September 23, 2003**

Schmid & Partner Engineering AG hereby certifies that conversion factor(s) of this probe have been evaluated on the date indicated above. The assessment was performed using the FDTD numerical code SEMCAD of Schmid & Partner Engineering AG. Since the evaluation is coupled with measured conversion factors, it has to be recalculated yearly, i.e., following the re-calibration schedule of the probe. The uncertainty of the numerical assessment is based on the extrapolation from measured value at 900 MHz or at 1800 MHz.

Assessed by:



## Dosimetric E-Field Probe ES3DV2 SN:3022

Conversion factor ( $\pm$  standard deviation)

**1950 MHz**                  ConvF                  **4.7  $\pm$  9.5%**

$\epsilon = 40.0 \pm 5\%$ $\sigma = 1.40 \pm 5\% \text{ mho/m}$ (head tissue)
---

**1950 MHz**                  ConvF                  **4.3  $\pm$  9.5%**

$\epsilon = 53.3 \pm 5\%$ $\sigma = 1.52 \pm 5\% \text{ mho/m}$ (body tissue)
---

## Additional Conversion Factors for Dosimetric E-Field Probe

Type:	<b>ES3DV2</b>
Serial Number:	<b>3022</b>
Place of Assessment:	<b>Zurich</b>
Date of Assessment:	<b>October 3, 2003</b>
Probe Calibration Date:	<b>September 23, 2003</b>

Schmid & Partner Engineering AG hereby certifies that conversion factor(s) of this probe have been evaluated on the date indicated above. The assessment was performed using the FDTD numerical code SEMCAD of Schmid & Partner Engineering AG. Since the evaluation is coupled with measured conversion factors, it has to be recalculated yearly, i.e., following the re-calibration schedule of the probe. The uncertainty of the numerical assessment is based on the extrapolation from measured value at 900 MHz or at 1800 MHz.

Assessed by:

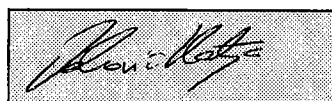

## Dosimetric E-Field Probe ES3DV2 SN:3022

Conversion factor ( $\pm$  standard deviation)

150 MHz	ConvF	8.5 $\pm$ 8%	$\epsilon_r = 52.3 \pm 5\%$ $\sigma = 0.76 \pm 5\%$ mho/m (head tissue)
150 MHz	ConvF	8.0 $\pm$ 8%	$\epsilon_r = 61.9 \pm 5\%$ $\sigma = 0.80 \pm 5\%$ mho/m (body tissue)
450 MHz	ConvF	7.1 $\pm$ 8%	$\epsilon_r = 43.5 \pm 5\%$ $\sigma = 0.87 \pm 5\%$ mho/m (head tissue)
450 MHz	ConvF	7.2 $\pm$ 8%	$\epsilon_r = 56.7 \pm 5\%$ $\sigma = 0.94 \pm 5\%$ mho/m (body tissue)

## **Additional Conversion Factors**

**for Dosimetric E-Field Probe**

Type:

**ES3DV2**

Serial Number:

**3022**

Place of Assessment:

**Zurich**

Date of Assessment:

**November 28, 2003**

Probe Calibration Date:

**September 23, 2003**

Schmid & Partner Engineering AG hereby certifies that conversion factor(s) of this probe have been evaluated on the date indicated above. The assessment was performed using the FDTD numerical code SEMCAD of Schmid & Partner Engineering AG. Since the evaluation is coupled with measured conversion factors, it has to be recalculated yearly, i.e., following the re-calibration schedule of the probe. The uncertainty of the numerical assessment is based on the extrapolation from measured value at 900 MHz or at 1800 MHz.

Assessed by:

## Dosimetric E-Field Probe ES3DV2 SN:3022

Conversion factor ( $\pm$  standard deviation)

<b>1600 MHz</b>	ConvF	<b>5.2 <math>\pm</math> 8%</b>	$\square = 40.3 \pm 5\%$ $\square = 1.29 \pm 5\%$ mho/m (head tissue)
<b>1600 MHz</b>	ConvF	<b>4.9 <math>\pm</math> 8%</b>	$\square = 53.8 \pm 5\%$ $\square = 1.40 \pm 5\%$ mho/m (body tissue)

## **Additional Conversion Factors**

**for Dosimetric E-Field Probe**

Type:

**ES3DV2**

Serial Number:

**3022**

Place of Assessment:

**Zurich**

Date of Assessment:

**December 9, 2003**

Probe Calibration Date:

**September 23, 2003**

Schmid & Partner Engineering AG hereby certifies that conversion factor(s) of this probe have been evaluated on the date indicated above. The assessment was performed using the FDTD numerical code SEMCAD of Schmid & Partner Engineering AG. Since the evaluation is coupled with measured conversion factors, it has to be recalculated yearly, i.e., following the re-calibration schedule of the probe. The uncertainty of the numerical assessment is based on the extrapolation from measured value at 900 MHz or at 1800 MHz.

Assessed by:

## **Dosimetric E-Field Probe ES3DV2 SN:3022**

Conversion factor ( $\pm$  standard deviation)

**2140 MHz**                      ConvF                      **4.5  $\pm$  8%**

$\square = 39.8 \pm 5\%$ $\square = 1.49 \pm 5\%$ mho/m (brain tissue)
--