

# 1. Set-Up for Tune-Up and Adjustment of Transmitter

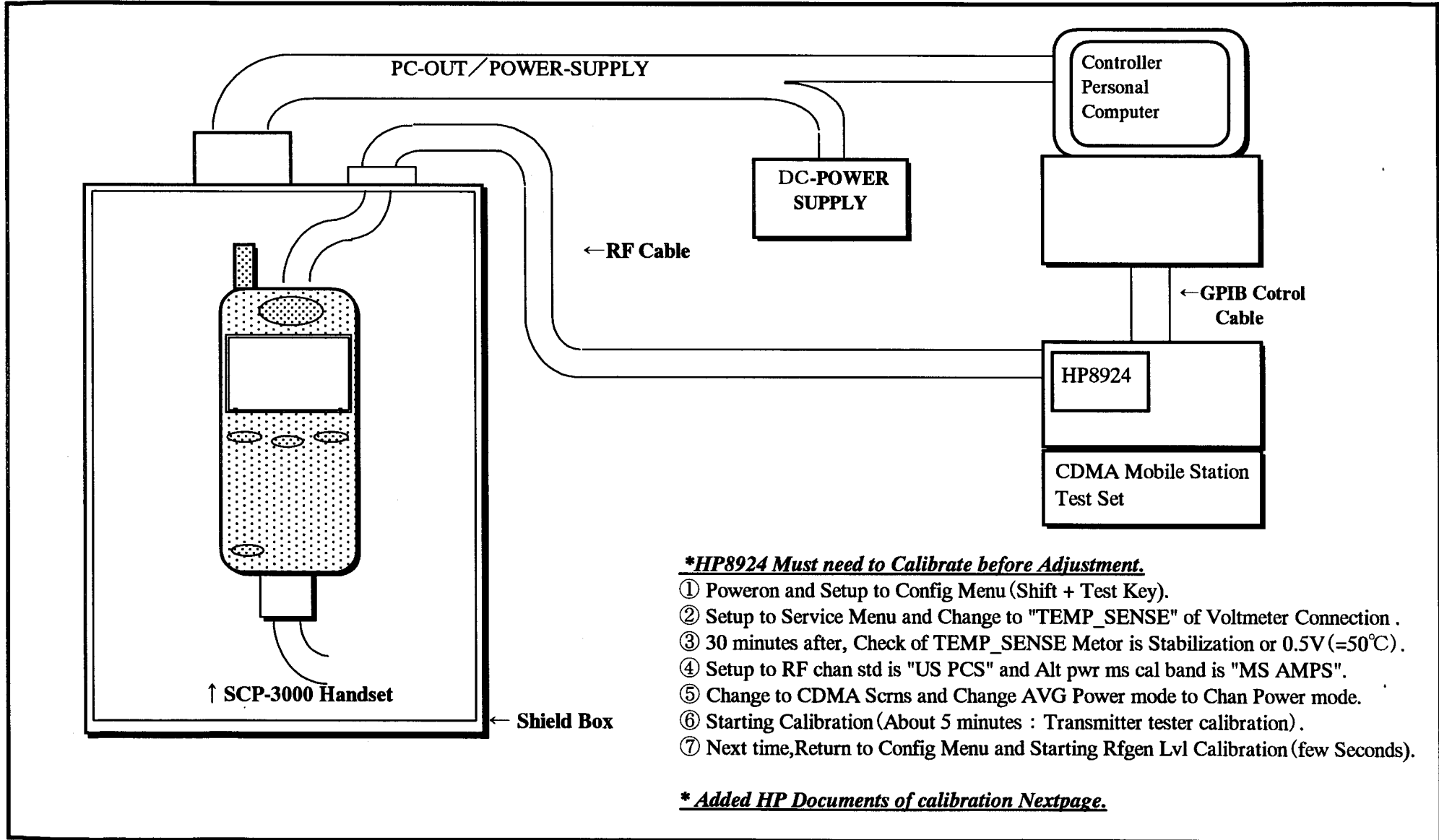

## 2. Alignment Procedure

### (1) Adjustment Procedure

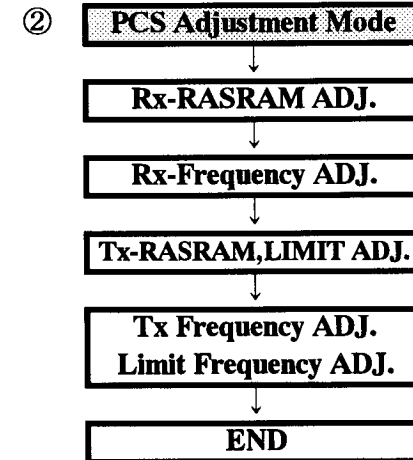
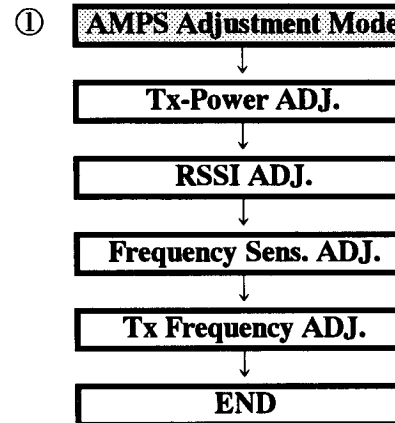
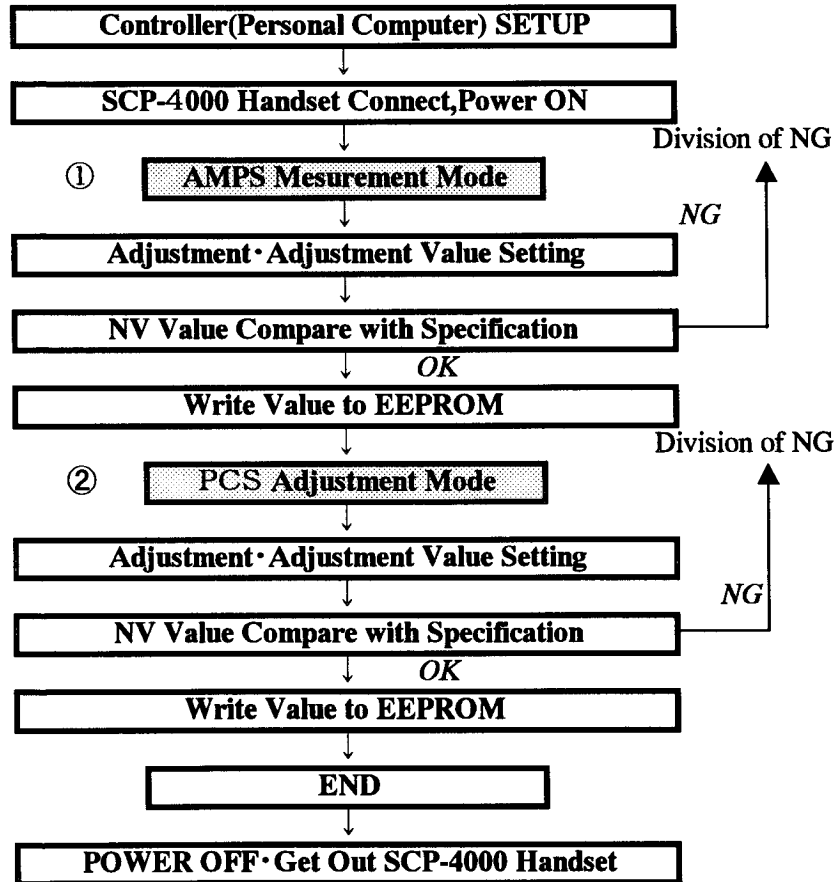

(2) Measurement Procedure

