

# KANSAI ELECTRONIC INDUSTRY DEVELOPMENT CENTER

HEAD OFFICE  
6-8-7 NISHITENMA  
KITA-KU OSAKA 530-0047 JAPAN



Corporate Juridical Person

IKOMA TESTING LABORATORY  
12128 TAKAYAMA-CHO  
IKOMA-CITY NARA 630-0101 JAPAN

## TEST REPORT

Report No.A-008-04-C

Date: 14 June 2004

This test report is to certify that the tested device properly complies with the requirements of:

FCC Rules and Regulations Part 24 Personal Communications Services.

All the tests necessary to show compliance to the requirements were performed and these results met the specifications of requirement. The results of this report should not be construed to imply compliance of equipment other than that, which was tested. Unless the laboratory permission, this report should not be copied in part.

### 1. Applicant

Company Name : SANYO Electric Co., Ltd.  
Mailing Address : 1-1, Sanyo-cho, Daito-shi, Osaka, 574-8534 Japan

### 2. Identification of Tested Device

Type of Device : PHS Cell Station  
Type of Modulation : : Narrowband PCS : Broadband PCS  
Kind of Equipment Authorization : : DoC : Certification : Verification  
FCC ID : AEZPBS-CS100  
Device Name : PHS Cell Station  
Trade Name : SANYO  
Model Number : PBS-CS100  
Serial Number : UTS00001 : Prototype : Pre-production : Production  
Date of Manufacture : May 2004

### 3. Test Items and Procedure

: RF Conducted Power Measurement  
: Antenna Conducted Spurious Emission Measurement  
: Transmit Power (EIRP) Measurement  
: Radiated Spurious (EIRP) Measurement  
: Occupied Bandwidth Measurement  
: Band Edge RF Conducted Emission Measurement  
: Frequency Stability Measurement  
: Radiated Emission Measurement  
: AC Power Line Conducted Emission Measurement

Above all tests were performed under: FCC Part 2, 24 and ANSI C63.4 – 2001

: without deviation, : with deviation(details are found inside of this report)

### 4. Date of Test

Receipt of Test Sample : 26 May 2004  
Condition of Test Sample : : Damage is not found on the set.  
: Damage is found on the set. (Details are described in this report)  
Test Completed on : 2 June 2004

Seiichi Izumi

General Manager/ Ikoma Testing Laboratory

Table of Contents

<b>0. LABORATORY ACCREDITATION AND MEASUREMENT UNCERTAINTY .....</b>	<b>3</b>
0.1. Laboratory Accreditation .....	3
0.2. Measurement Uncertainty .....	3
<b>1. CERTIFICATION OF THE COMPLIANCE .....</b>	<b>3</b>
<b>2. GENERAL INFORMATION .....</b>	<b>4</b>
2.1. Product Description .....	4
2.2. Description for Equipment Authorization .....	5
2.3. Test Facility .....	5
<b>3. TESTED SYSTEM .....</b>	<b>6</b>
3.1. Test Mode .....	6
3.2. Characterization and condition of EUT System .....	6
3.3. Test Configuration .....	7
3.4. Block Diagram of EUT System .....	11
3.5. Test Arrangement on Radiated Spurious Emission Measurement .....	12
3.6. List of EUT System .....	13
3.7. List of Cables .....	13
<b>4. RF CONDUCTED POWER MEASUREMENT (§ 2.1046 (a) ) .....</b>	<b>14</b>
4.1. Test Procedure .....	14
4.2. Test Results .....	15
<b>5. ANTENNA CONDUCTED SPURIOUS EMISSION MEASUREMENT (§24.238) .....</b>	<b>18</b>
5.1. Test Procedure .....	18
5.2. Test Results .....	19
<b>6. TRANSMIT POWER (E. I. R. P) MEASUREMENT (§ 24.232) .....</b>	<b>27</b>
6.1. Test Procedure .....	27
6.2. Test Results .....	28
<b>7. RADIATED SPURIOUS (E. I. R. P) MEASUREMENT (§ 24.238) .....</b>	<b>32</b>
7.1. Test Procedure .....	32
7.2. Test Results .....	33
<b>8. OCCUPIED BANDWIDTH MEASUREMENT (§ 2.1049, §24.238) .....</b>	<b>41</b>
8.1. Test Procedure .....	41
8.2. Test Results .....	41
<b>9. BAND EDGE RF CONDUCTED EMISSION MEASUREMENT (§ 24.238) .....</b>	<b>45</b>
9.1. Test Procedure .....	45
9.2. Test Results .....	46
<b>10. FREQUENCY STABILITY MEASUREMENT (§ 2.1055, § 24.235) .....</b>	<b>49</b>
10.1. Test Procedure .....	49
10.2. Test Results .....	49
<b>11. RADIATED EMISSION MEASUREMENT (§ 15.247 c1) .....</b>	<b>52</b>
11.1. Test Procedure .....	52
11.2. Test Results .....	53
<b>12. AC POWER LINE CONDUCTED EMISSION MEASUREMENT (§ 15.247 c2) .....</b>	<b>55</b>
12.1. Test Procedure .....	55
12.2. Test Results .....	56
<b>13. USED TEST EQUIPMENTS AND CALIBRATION STATUS .....</b>	<b>57</b>

## 0. LABORATORY ACCREDITATION AND MEASUREMENT UNCERTAINTY

### 0.1. Laboratory Accreditation

KEC is accredited by the National Voluntary Laboratory Accreditation Program (NVLAP) for the specific scope of accreditation under Lab Code: 200207-0.

When the test report concerns with the NVLAP accreditation test, the first page of the test report is signed by NVLAP Approved Signatory accompanied by the NVLAP logo.

The report must not be used by the client to claim product endorsement by NVLAP or any agency of the U.S. Government.

### 0.2. Measurement Uncertainty

The result of a measurement is only an approximation or estimate of the value of a specific quantity. And thus the measured is complete only when a statement of uncertainty is given.

KEC quotes Measurement Uncertainty (U)

- of +/-  $3 \times 10^{-9}$  for Frequency Stability Measurement
- of +/- 0.7 dB for Peak Output Power Measurement
- of +/- 0.7 dB for Band Edge RF Conducted Measurement
- of +/- 0.7 dB for Spurious RF Conducted Emission Measurement
- of +/- 4.9 dB for Radiated Emissions
- of +/- 2.2 dB for Conducted Emissions

## 1. CERTIFICATION OF THE COMPLIANCE

This test report is to certify that the tested device properly complies with the requirements of FCC Rules Part 24 and Part 15 Subpart B unintentional.

The measured result is below the specification limit by a margin less than the measurement uncertainty; it is not therefore possible to determine compliance at a level of confidence of 95%. However, the measured result indicates higher probability that the product tested complies with the specification limit.

## 2. GENERAL INFORMATION

### 2.1. Product Description

The SANYO Model No. PBS-CS100 (referred as EUT in this report) is a PHS Cell Station.

#### (1) Technical Specifications

• radio channel	: 1C7T
• rated output power	: 500 mW (Average)
• Frequency Range	: 1880.15 – 1909.55 MHz
• Carrier Separation	: 300 kHz
• Occupied Bandwidth	: 288 kHz
• Modulation method	: $\pi/4$ shift QPSK
• Baud rate	: 384 kbps
• Transmission system	: Omni system
• Receiving system	: Adaptive array system
• Communication port	: I interface (2B+D, 2B, 2B, 2B)
• External Antenna	: Co – Liner array antenna (Impedance 50 $\Omega$ , Gain 10dBi)

#### (2) Used Oscillating Frequency

• System Clock	: 19.2 MHz
• 1st IF	: 12 MHz
• 1st IFLO	: 9.6 MHz
• 2nd IF	: 10.8 MHz
• 2nd IFLO	: 233.15 MHz
• 3rd IF	: 243.95 MHz
• RF LO	: 1636.2 ~ 1665.6 MHz
• CPU Clock (Central control part)	: 4.9152 MHz
• CPU Clock (Wireless-radio-control part)	: 33 MHz
• DSP Clock (Radio signal processing part)	: 50 MHz

#### (3) Provided Terminals

• ANT	: Antenna port (4port, connector : type N)
• AC Input	: for AC power input
• GPS connector	: for GPS Antenna
• L1~4	: ISDN port
• Cascade connector	: USB terminal
• Login connector	: RS-232C, inside of EUT

(4) Rated Power Supply : AC 85V~286V, 50/60Hz

## 2.2. Description for Equipment Authorization

(1) Type of device	: <input checked="" type="checkbox"/> Intentional Raidators
(2) Reference Rule and Specification	: FCC Rule Part 24 Subpart E, Broadband PCS
(3) Kind of Equipment Authorization	: <input type="checkbox"/> DoC <input checked="" type="checkbox"/> Certification <input type="checkbox"/> Verification
(4) Highest Frequency used in the Device	: 1880.15~1909.55MHz
(5) Upper Frequency of Radiated Emission Measurement Range	: <input type="checkbox"/> 1000 MHz <input type="checkbox"/> 2000 MHz <input type="checkbox"/> 5000 MHz <input checked="" type="checkbox"/> Tenth harmonics of the highest fundamental frequency

## 2.3. Test Facility

All tests described in this report were performed by:	
Name:	KANSAI ELECTRONIC INDUSTRY DEVELOPMENT CENTER (KEC) IKOMA TESTING LABORATORY
Open Area Test Site	<input type="checkbox"/> No.1 <input type="checkbox"/> No.4
Anechoic Chamber	<input checked="" type="checkbox"/> No.1 <input type="checkbox"/> No.3
Shielded Room	<input type="checkbox"/> No.1 <input type="checkbox"/> No.2 <input checked="" type="checkbox"/> No.4 <input type="checkbox"/> No.5
Address:	12128, Takayama-cho Ikoma-city, Nara, 630-0101 Japan
<p>These test facilities have been filed with the FCC under the criteria of ANSI C63.4-2001. The KEC has been accredited by the NVLAP (Lab. Code: 200207-0) based on ISO/IEC 17025.  Also the laboratory has been authorized by TUV Product Service (GER) and TUV Rheinland (GER) based on their criteria for testing laboratory (ISO/IEC 17025).</p>	

### 3. TESTED SYSTEM

#### 3.1. Test Mode

The following operation modes were used under the test.

- Op-mode 1 : Transmitting at 1880.15 MHz (ch. 206), ANT1 to 4 with modulation
- Op-mode 2 : Transmitting at 1894.85 MHz (ch. 255), ANT 1 to 4 with modulation
- Op-mode 3 : Transmitting at 1909.55 MHz (ch. 49), ANT 1 to 4 with modulation
- Op-mode 4 : Receiving at ch. 49
- Op-mode 5 : Receiving at ch. 255
- Op-mode 6 : Receiving at ch. 206

- a) RF Conducted Power : Op-mode 1, 2, 3
- b) Antenna Conducted Spurious measurement : Op-mode 1, 2, 3
- c) Transmit Power (EIRP) measurement : Op-mode 1, 2, 3
- d) Radiated Spurious (EIRP) measurement : Op-mode 1, 2, 3
- e) Occupied Bandwidth measurement : Op-mode 1, 2, 3
- f) Band Edge RF Conducted measurement : Op-mode 1, 3
- g) Frequency Stability measurement : Op-mode 1, 2, 3 (ANTENNA 1 only)
- h) Radiated Emission measurement : Op-mode 1, 2, 3, 4, 5, 6
- i) AC Power Line Conducted Emission measurement : Op-mode 1, 2, 3, 4, 5, 6

[Note]

In Radiated Emission measurement and AC Power Line Conducted Emission measurements, the data the emission were checked above 6 operation modes. As a results, the data that produce the maximum emission were reported at each frequency.

#### 3.2. Characterization and condition of EUT System

: normal ,  : not normal (that is )

### 3.3. Test Configuration

- RF Conducted Power Measurement
- Occupied Bandwidth Measurement
- Bandedge RF Conducted Emission Measurement

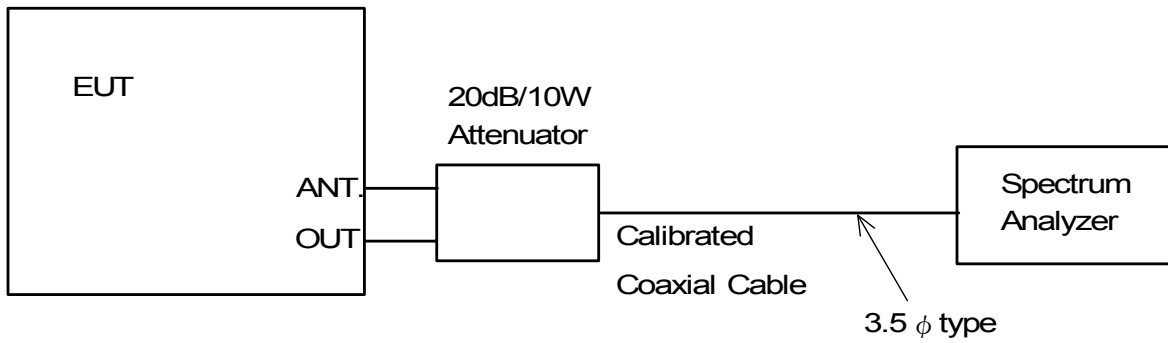

- Antenna Conducted Spurious Measurement

(1) Frequency Range 30 MHz – 5.8 GHz

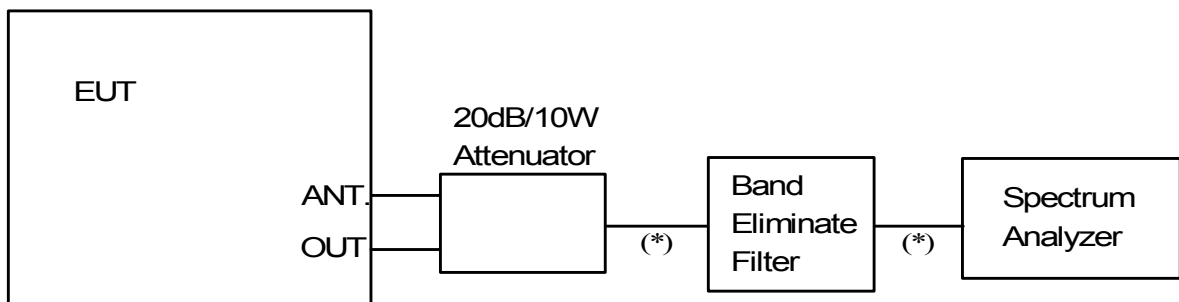

(2) Frequency Range 5.8 GHz – 20 GHz

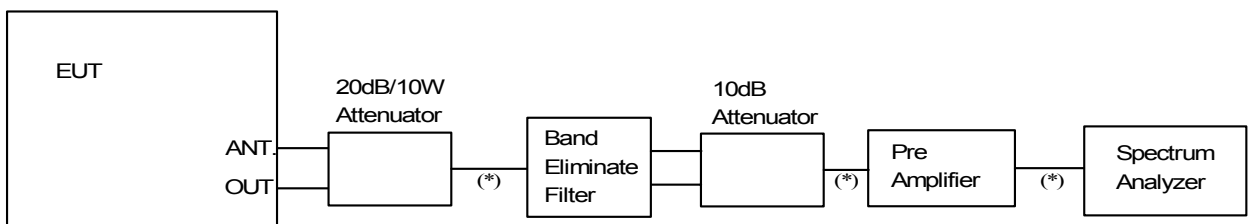

(\*) : Calibrated 3.5 φ type coaxial cable

- Continued -

- Transmit Power (EIRP) measurement
- Radiated Spurious (EIRP) measurement
- Radiated Emission measurement

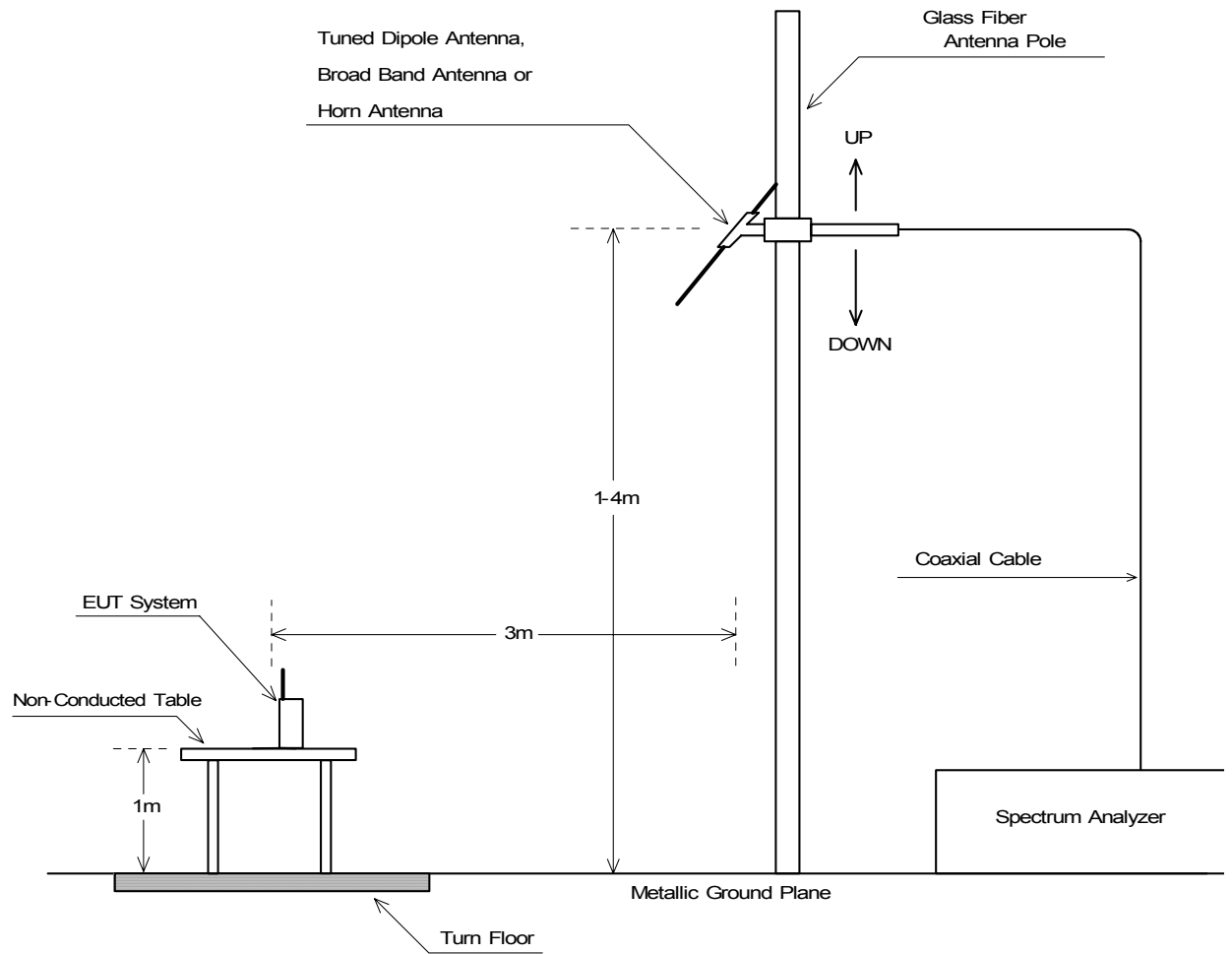



- Continued -

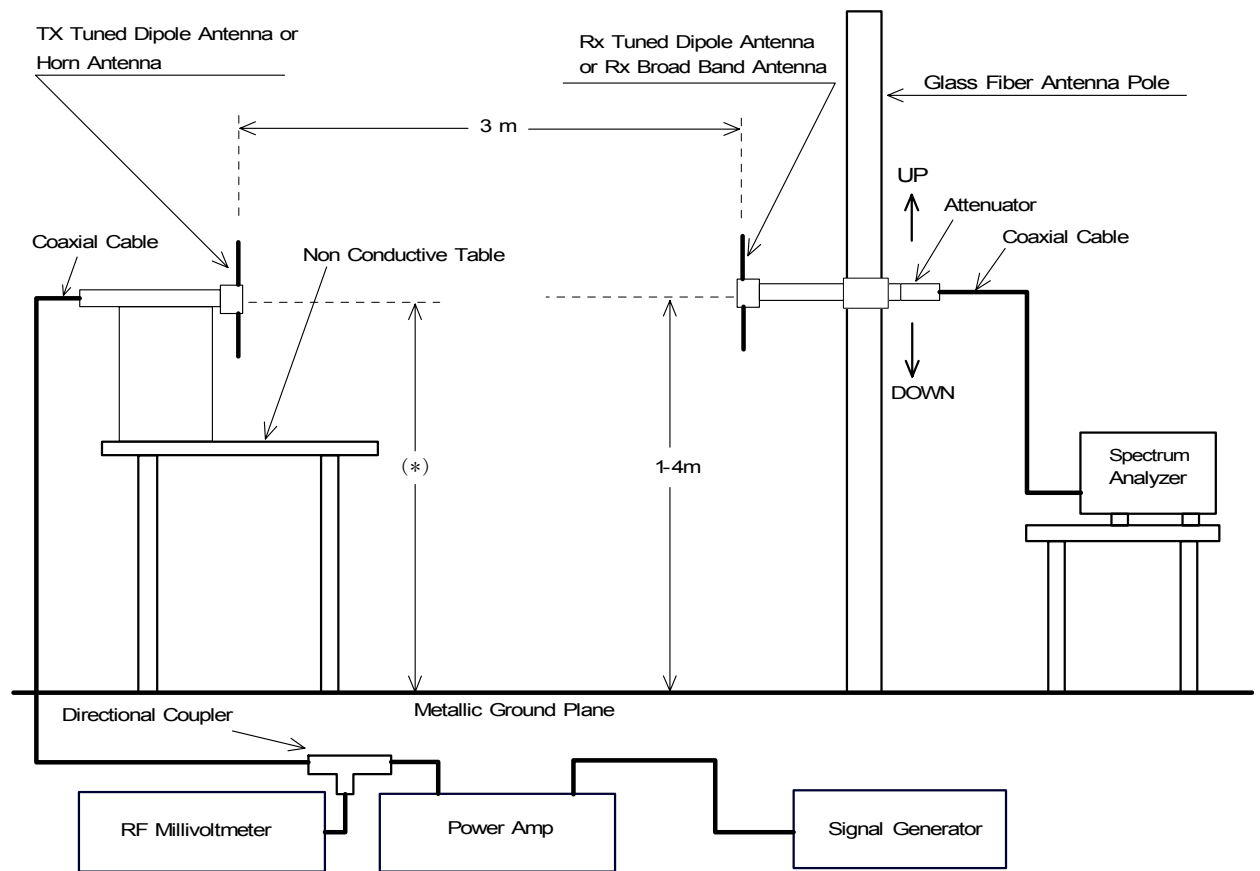

[Note]

(\*) : Center of the array antenna height (See page 12).

- Continued -

• AC Power Line Conducted Emission Measurement

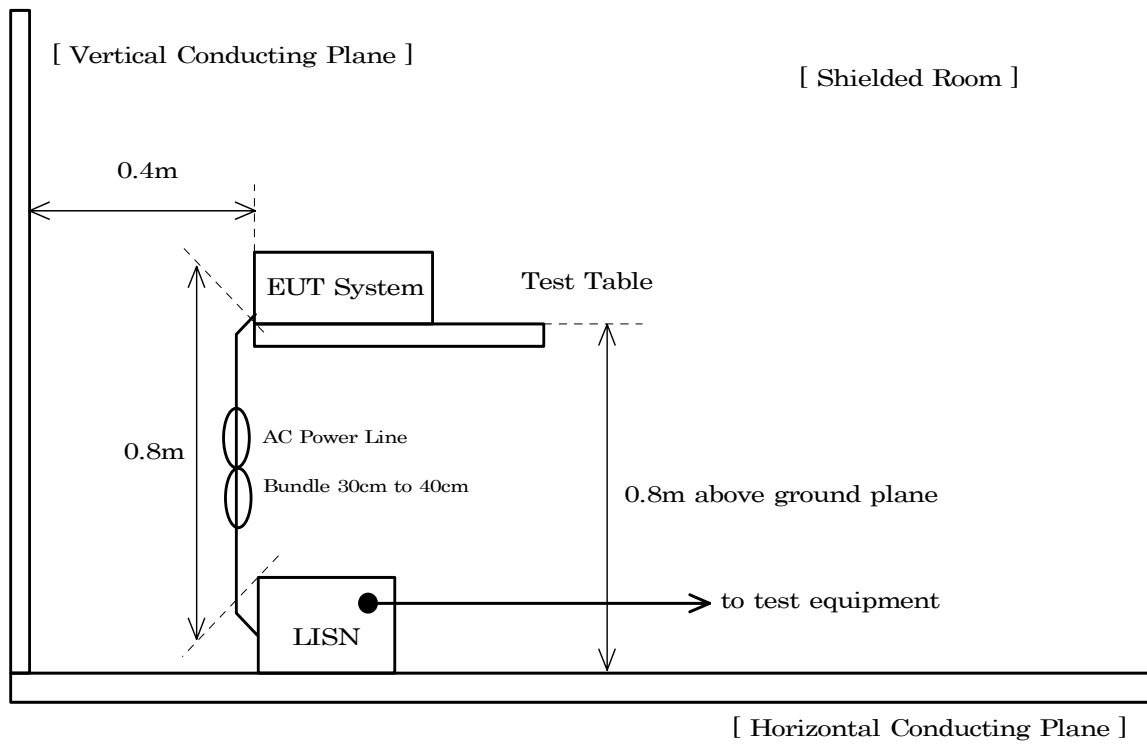

## 3.4. Block Diagram of EUT System

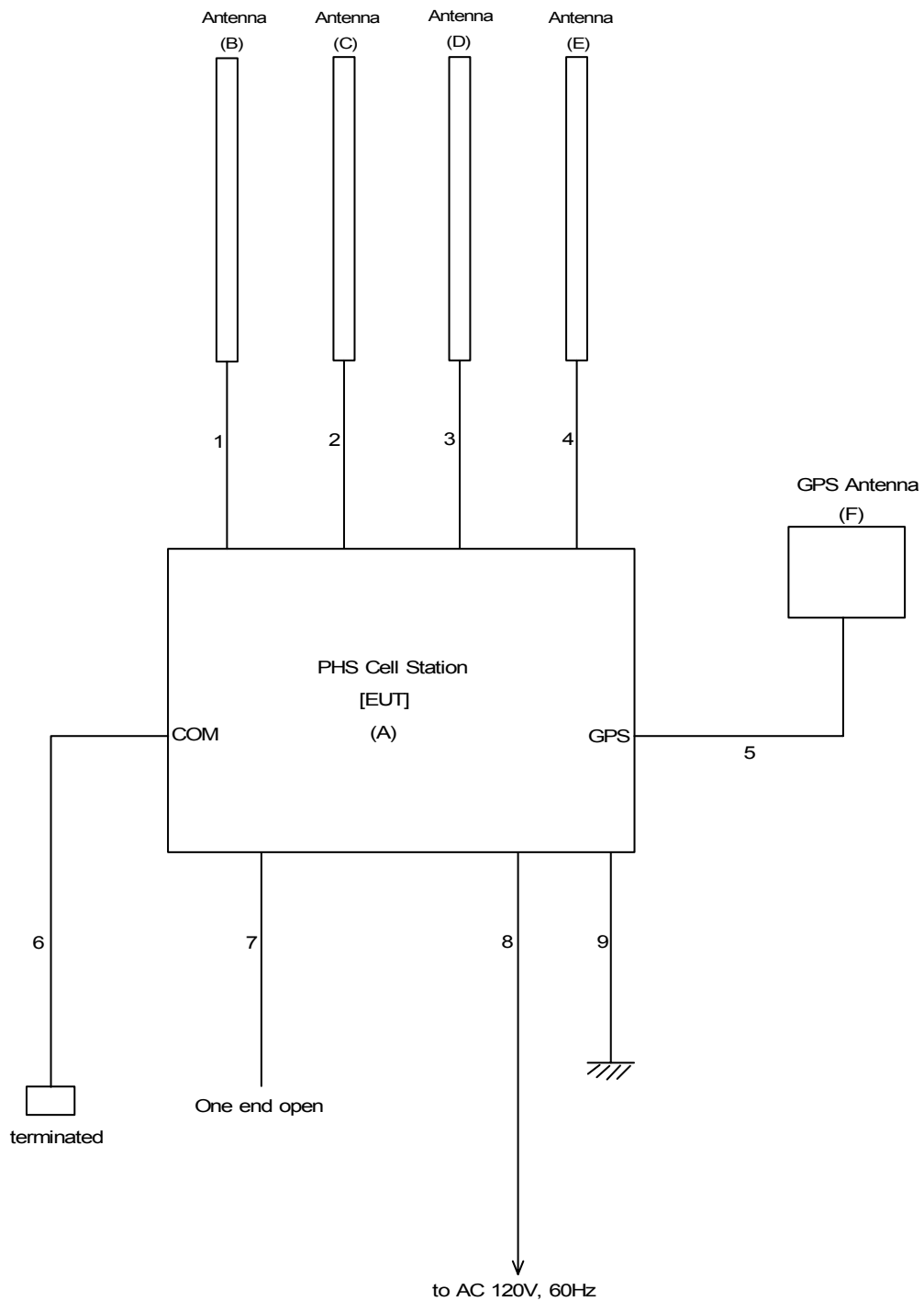

## [Note]

- (1) Transmit Power, Radiated spurious, Radiated Emission and AC Power Line Conducted Emission measurement were performed above block diagram.  
In other test items, (B) to (E) above figure were removed and connecting the spectrum analyzer by using both of an attenuator and calibrated coaxial cables.
- (2) See 3.6 List of EUT System and 3.7 List of Cables.

### 3.5. Test Arrangement on Radiated Spurious Emission Measurement

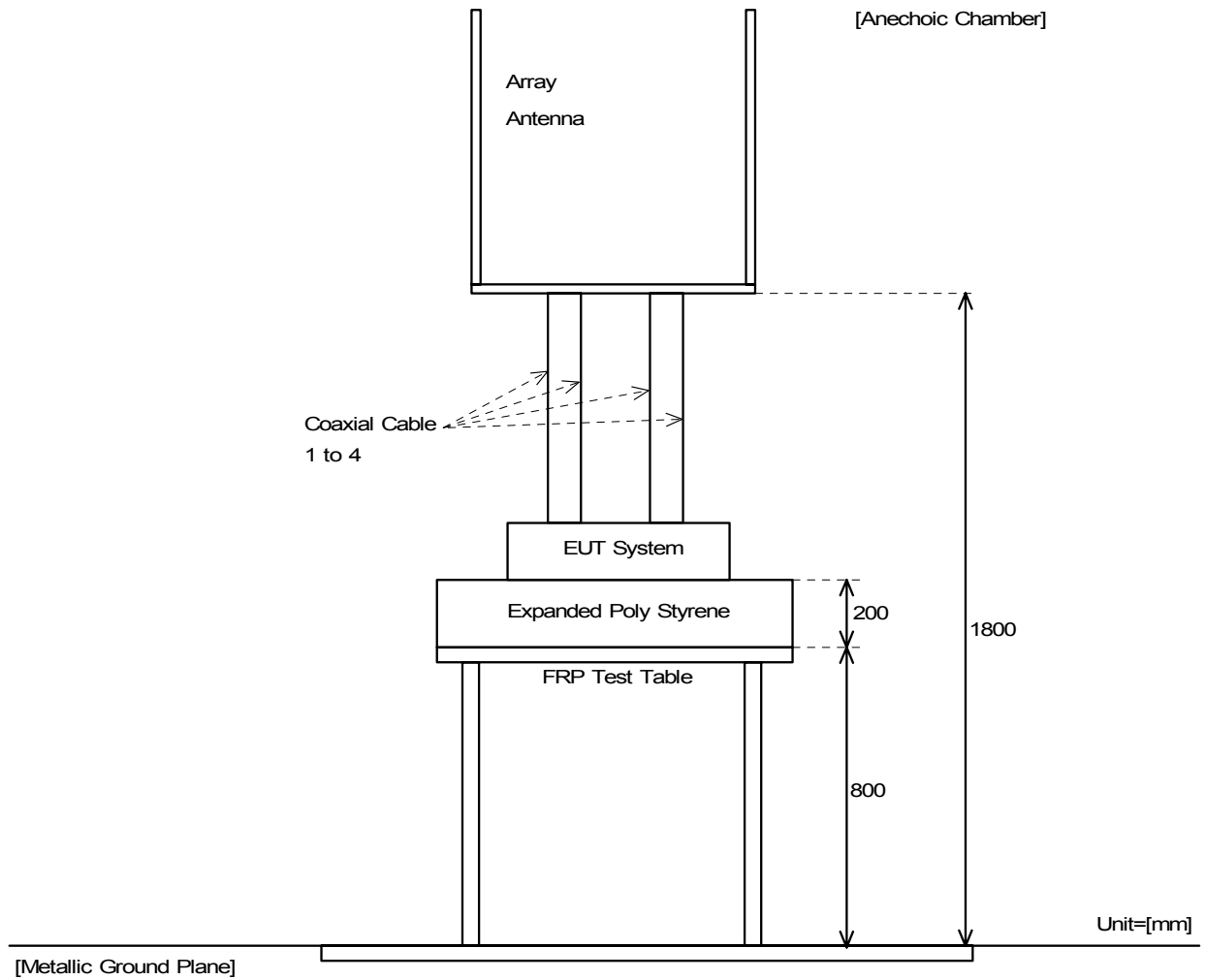

## 3.6. List of EUT System

No	Device Name (Interface)	Model Number (Serial Number)	FCC ID (Trade Name)	Note	Remark
A	PHS Cell Station	PBS-CS100 (UTS00001)	AEZPBS-CS100 (SANYO)	EUT	
B	Antenna	ST-01GD(8)T10 (0000107)	N/A (NIPPON ANTENNA)		
C	Antenna	ST-01GD(8)T10 (0000105)	N/A (NIPPON ANTENNA)		
D	Antenna	ST-01GD(8)T10 (0000106)	N/A (NIPPON ANTENNA)		
E	Antenna	ST-01GD(8)T10 (0000108)	N/A (NIPPON ANTENNA)		
F	GPS Antenna	Acutime 2000 (12312986)	N/A (Trimble Navigation)	FCC ID : Declaration of Comformity	

[Attention]

N/A : Not Applicable

## 3.7. List of Cables

No	Cable Name	Model No. (Trade Name)	Shielded (Y/N)	Length ( m )	Note	Remark
1	Coaxial Cable	— ( — )	Y	1.2		
2	Coaxial Cable	— ( — )	Y	1.2		
3	Coaxial Cable	— ( — )	Y	1.2		
4	Coaxial Cable	— ( — )	Y	1.2		
5	GPS Cable	— ( — )	Y	10.0		
6	Circuit Cable	— ( — )	Y	2.0	terminated correctly impedance	
7	Extend I/F Cable	— ( — )	Y	3.0	one end open	
8	Power Cable	— ( — )	Y	2.0	3-wires type, Permanently attached to the EUT	
9	Earth Cable	— ( — )	N	1.0		

#### 4. RF CONDUCTED POWER MEASUREMENT (§ 2.1046 (a) )

##### 4.1. Test Procedure

- (1) Connect the EUT RF output port to spectrum analyzer via calibrated coaxial cable and suitable attenuator (if necessary).
- (2) Activates the EUT System and executes the software prepared for test, if necessary.
- (3) To find out the worst case, the transmitting data rate of EUT is varied with the different modes of operation. The final test condition is recorded in this report.
- (4) The spectrums are scanned and allow the trace to stabilize.
- (5) The peak output power was determined by using the marker-data function of spectrum analyzer (\*1).

[Note]

(\*1) Spectrum Analyzer Set Up Conditions

Resolution bandwidth	: 1 MHz
Video bandwidth	: $\geq$ RBW
Sweep	: Auto
Detector function	: Peak
Trace Mode	: Max Hold

## 4.2. Test Results

Test Port : ANT.1

ch.	Measured Frequency [ MHz ]	Correction Factor (*) [ dB ]	Meter Reading [ dBm ]	Peak Output Power [ dBm ]	Peak Output Power [ W ]	Limits [ W ]	Margin For Limits [ dB ]
206	1880.15	20.6	17.3	37.9	6.2	100.0	12.1
255	1894.85	20.6	17.3	37.9	6.2	100.0	12.1
49	1909.55	20.6	17.3	37.9	6.2	100.0	12.1

Test Port : ANT.2

ch.	Measured Frequency [ MHz ]	Correction Factor (*) [ dB ]	Meter Reading [ dBm ]	Peak Output Power [ dBm ]	Peak Output Power [ W ]	Limits [ W ]	Margin For Limits [ dB ]
206	1880.15	20.6	17.3	37.9	6.2	100.0	12.1
255	1894.85	20.6	17.3	37.9	6.2	100.0	12.1
49	1909.55	20.6	17.3	37.9	6.2	100.0	12.1

Test Port : ANT.3

ch.	Measured Frequency [ MHz ]	Correction Factor (*) [ dB ]	Meter Reading [ dBm ]	Peak Output Power [ dBm ]	Peak Output Power [ W ]	Limits [ W ]	Margin For Limits [ dB ]
206	1880.15	20.6	17.3	37.9	6.2	100.0	12.1
255	1894.85	20.6	17.3	37.9	6.2	100.0	12.1
49	1909.55	20.6	17.2	37.8	6.0	100.0	12.2

Test Port : ANT.4

ch.	Measured Frequency [ MHz ]	Correction Factor (*) [ dB ]	Meter Reading [ dBm ]	Peak Output Power [ dBm ]	Peak Output Power [ W ]	Limits [ W ]	Margin For Limits [ dB ]
206	1880.15	20.6	17.2	37.8	6.0	100.0	12.2
255	1894.85	20.6	17.2	37.8	6.0	100.0	12.2
49	1909.55	20.6	17.3	37.9	6.2	100.0	12.1

- Continued -

[Note] (1) (*) : Correction Factor is includes the both loss of attenuator and cable used in the measurement. (2) See next page figure 1, 2. (Modulation Character)
[Calculation method] Peak Output Power ( dBm ) = Meter Reading ( dBm ) + Correction Factor (dB)
[Test Condition] EUT operation : Op-mode 1, 2, 3, 4 Output Ant. : 1 to 4

[ Environment ]

Temperature 24°C Humidity 42%

[ Tested Date / Tester ]

28 May 2004

Signature



Ikuya Minematsu



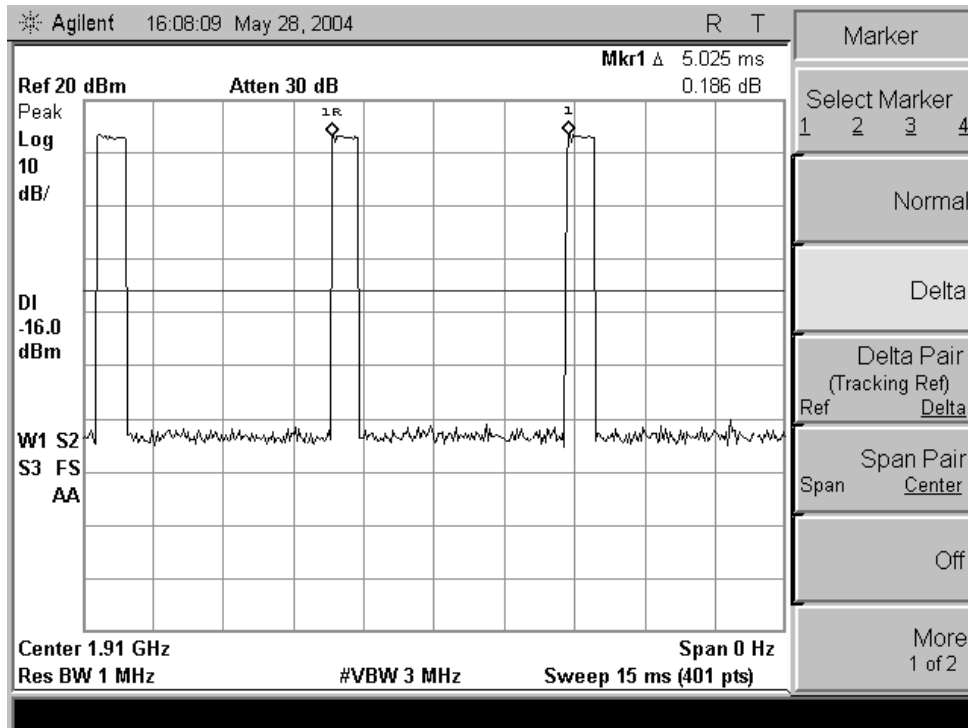

figure 1 (Modulation Characteristics)

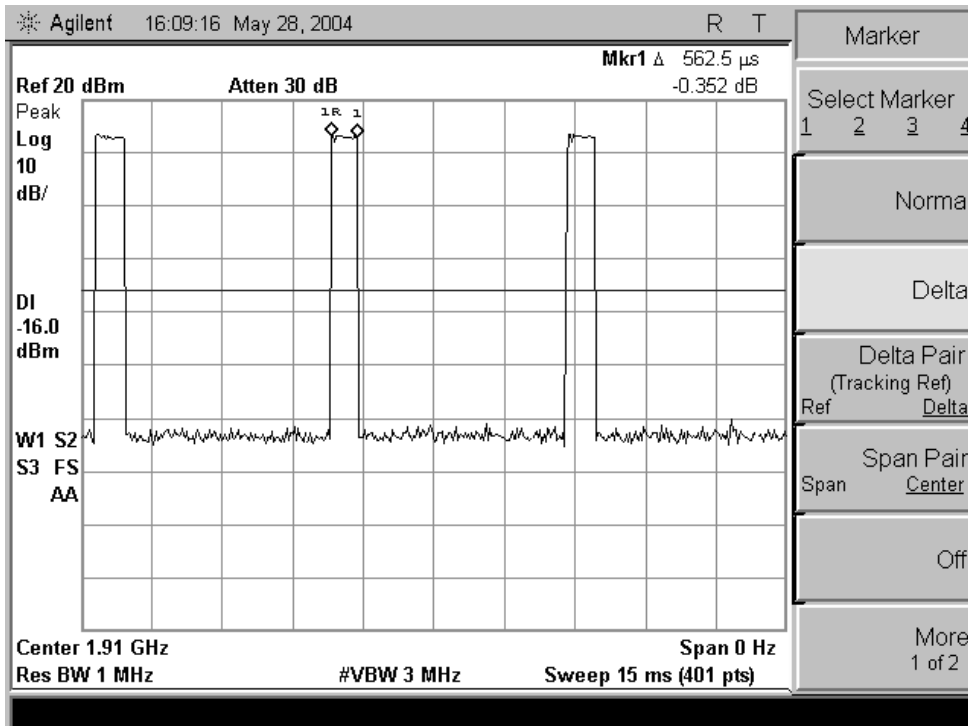

figure 2 (Modulation Characteristics)

## 5. ANTENNA CONDUCTED SPURIOUS EMISSION MEASUREMENT (§24.238)

### 5.1. Test Procedure

- |     |  |
|-----|--|
| (1) | Connect the EUT RF output port to the spectrum analyzer via calibrated coaxial cable and suitable attenuator (if necessary).       |
| (2) | Activates the EUT System and executes the software prepared for test, if necessary.  |
| (3) | The Spectrums are scanned from the lowest generated frequency of EUT up to the 10th harmonics by using the spectrum analyzer (*1). |

[Note]

(\*1) Spectrum Analyzer Set Up Conditions

Resolution bandwidth	: 1 MHz (Above 1 GHz), 100 kHz (30 MHz to 1000 MHz)
Video bandwidth	: More than RBW
Sweep	: Auto
Detector function	: Peak detector
Trance	: Max Hold

## 5.2. Test Results

Test Port : ANT.1 (Tx Frequency : 1880.15 MHz ) 6.2 [ W ]

Measured Frequency [ MHz ]	Correction Factor (*) [ dB ]	Meter Reading [ dBm ]	Spurious Emission [ dBm ]	Limit (*2) [ dBm ]	Margin For Limit [ dB ]
[ Harmonics & Other Emission ]					
3760.30	24.5	-65.5	-41.0	-13.0	28.0
5640.45	26.1	<-68.0	<-41.9	-13.0	>28.9
7520.60	-8.0	-52.3	-60.3	-13.0	47.3
9400.75	-6.9	<-62.0	<-68.9	-13.0	>55.9
11280.90	-4.9	<-62.0	<-66.9	-13.0	>53.9
13161.05	12.0	<-62.0	<-50.0	-13.0	>37.0
15041.20	-1.5	<-62.0	<-63.5	-13.0	>50.5
16921.35	14.3	<-62.0	<-47.7	-13.0	>34.7
18801.50	13.0	<-62.0	<-49.0	-13.0	>36.0

Test Port : ANT.1 (Tx Frequency : 1894.85 MHz ) 6.2 [ W ]

Measured Frequency [ MHz ]	Correction Factor (*) [ dB ]	Meter Reading [ dBm ]	Spurious Emission [ dBm ]	Limit (*2) [ dBm ]	Margin For Limit [ dB ]
[ Harmonics & Other Emission ]					
3789.70	24.5	-64.5	-40.0	-13.0	27.0
5684.55	25.7	<-68.0	<-42.3	-13.0	>29.3
7579.40	-8.0	-52.7	-60.7	-13.0	47.7
9474.25	-6.8	-59.6	-66.4	-13.0	53.4
11369.10	-4.9	<-62.0	<-66.9	-13.0	>53.9
13263.95	5.4	<-62.0	<-57.6	-13.0	>44.6
15158.80	-1.4	<-62.0	<-63.4	-13.0	>50.4
17053.65	11.6	<-62.0	<-50.4	-13.0	>37.4
18948.50	13.9	<-62.0	<-48.1	-13.0	>35.1

- Continued -

Test Port : ANT.1 (Tx Frequency : 1909.55 MHz ) 6.2 [ W ]

Measured Frequency [ MHz ]	Correction Factor (*) [ dB ]	Meter Reading [ dBm ]	Spurious Emission [ dBm ]	Limit (*2) [ dBm ]	Margin For Limit [ dB ]
[ Harmonics & Other Emission ]					
3819.10	24.4	-65.0	-40.6	-13.0	27.6
5728.65	25.6	<-68.0	<-42.4	-13.0	>29.4
7638.20	-8.0	-54.0	-62.0	-13.0	49.0
9547.75	-7.0	-58.5	-65.5	-13.0	52.5
11457.30	-5.0	<-62.0	<-67.0	-13.0	>54.0
13366.85	1.9	<-62.0	<-60.1	-13.0	>47.1
15276.40	-0.2	<-62.0	<-62.2	-13.0	>49.2
17185.95	10.6	<-62.0	<-51.4	-13.0	>38.4
19095.50	13.5	<-62.0	<-48.5	-13.0	>35.5

Test Port : ANT. 2 (Tx Frequency : 1880.15 MHz) 6.2 [ W ]

Measured Frequency [ MHz ]	Correction Factor (*) [ dB ]	Meter Reading [ dBm ]	Spurious Emission [ dBm ]	Limit (*2) [ dBm ]	Margin For Limit [ dB ]
[ Harmonics & Other Emission ]					
3760.30	24.5	-65.1	-40.6	-13.0	27.6
5640.45	26.1	<-68.0	<-41.9	-13.0	>28.9
7520.60	-8.0	-57.0	-65.0	-13.0	52.0
9400.75	-6.9	-59.0	-65.9	-13.0	52.9
11280.90	-4.9	<-62.0	<-66.9	-13.0	>53.9
13161.05	12.0	<-62.0	<-50.0	-13.0	>37.0
15041.20	-1.5	<-62.0	<-63.5	-13.0	>50.5
16921.35	14.3	<-62.0	<-47.7	-13.0	>34.7
18801.50	13.0	<-62.0	<-49.0	-13.0	>36.0

Test Port : ANT. 2 (Tx Frequency : 1894.85 MHz) 6.2 [ W ]

Measured Frequency [ MHz ]	Correction Factor (*) [ dB ]	Meter Reading [ dBm ]	Spurious Emission [ dBm ]	Limit (*2) [ dBm ]	Margin For Limit [ dB ]
[ Harmonics & Other Emission ]					
3789.70	24.5	-63.9	-39.4	-13.0	26.4
5684.55	25.7	<-68.0	<-42.3	-13.0	>29.3
7579.40	-8.0	-55.0	-63.0	-13.0	50.0
9474.25	-6.8	-58.9	-65.7	-13.0	52.7
11369.10	-4.9	<-62.0	<-66.9	-13.0	>53.9
13263.95	5.4	<-62.0	<-56.6	-13.0	>43.6
15158.80	-1.4	<-62.0	<-63.4	-13.0	>50.4
17053.65	11.6	<-62.0	<-50.4	-13.0	>37.4
18948.50	13.9	<-62.0	<-48.1	-13.0	>35.1

- Continued -

Test Port : ANT. 2 (Tx Frequency : 1909.55 MHz) 6.2 [ W ]

Measured Frequency [ MHz ]	Correction Factor (*) [ dB ]	Meter Reading [ dBm ]	Spurious Emission [ dBm ]	Limit (*2) [ dBm ]	Margin For Limit [ dB ]
[ Harmonics & Other Emission ]					
3819.10	24.4	-65.3	-40.9	-13.0	27.9
5728.65	25.6	<-68.0	<-42.4	-13.0	>29.4
7638.20	-8.0	-55.5	-63.5	-13.0	50.5
9547.75	-7.0	<-62.0	<-69.0	-13.0	>56.0
11457.30	-5.0	<-62.0	<-67.0	-13.0	>54.0
13366.85	1.9	<-62.0	<-60.1	-13.0	>47.1
15276.40	-0.2	<-62.0	<-62.2	-13.0	>49.2
17185.95	10.6	<-62.0	<-51.4	-13.0	>38.4
19095.50	13.5	<-62.0	<-48.5	-13.0	>35.5

Test Port : ANT. 3 (Tx Frequency : 1880.15 MHz) 6.2 [ W ]

Measured Frequency [ MHz ]	Correction Factor (*) [ dB ]	Meter Reading [ dBm ]	Spurious Emission [ dBm ]	Limit (*2) [ dBm ]	Margin For Limit [ dB ]
[ Harmonics & Other Emission ]					
3760.30	24.5	-64.1	-39.6	-13.0	26.6
5640.45	26.1	<-68.0	<-41.9	-13.0	>28.9
7520.60	-8.0	-50.7	-58.7	-13.0	45.7
9400.75	-6.9	-53.6	-60.5	-13.0	47.5
11280.90	-4.9	-55.8	-60.7	-13.0	47.7
13161.05	12.0	<-62.0	<-50.0	-13.0	>37.0
15041.20	-1.5	<-62.0	<-63.5	-13.0	>50.5
16921.35	14.3	<-62.0	<-47.7	-13.0	>34.7
18801.50	13.0	<-62.0	<-49.0	-13.0	>36.0

Test Port : ANT. 3 (Tx Frequency : 1894.85 MHz) 6.2 [ W ]

Measured Frequency [ MHz ]	Correction Factor (*) [ dB ]	Meter Reading [ dBm ]	Spurious Emission [ dBm ]	Limit (*2) [ dBm ]	Margin For Limit [ dB ]
[ Harmonics & Other Emission ]					
3789.70	24.5	-62.8	-38.3	-13.0	25.3
5684.55	25.7	<-68.0	<-42.3	-13.0	>29.3
7579.40	-8.0	-50.3	-58.3	-13.0	45.3
9474.25	-6.8	-56.5	-63.3	-13.0	50.3
11369.10	-4.9	-58.9	-63.8	-13.0	50.8
13263.95	5.4	<-62.0	<-56.6	-13.0	>43.6
15158.80	-1.4	<-62.0	<-63.4	-13.0	>50.4
17053.65	11.6	<-62.0	<-50.4	-13.0	>37.4
18948.50	13.9	<-62.0	<-48.1	-13.0	>35.1

- Continued -

Test Port : ANT. 3 (Tx Frequency : 1909.55 MHz) 6.0 [ W ]

Measured Frequency [ MHz ]	Correction Factor (*) [ dB ]	Meter Reading [ dBm ]	Spurious Emission [ dBm ]	Limit (*2) [ dBm ]	Margin For Limit [ dB ]
[ Harmonics & Other Emission ]					
3819.10	24.4	-64.8	-40.4	-13.0	27.4
5728.65	25.6	<-68.0	<-42.4	-13.0	>29.4
7638.20	-8.0	-49.9	-57.9	-13.0	44.9
9547.75	-7.0	<-62.0	<-69.0	-13.0	>56.0
11457.30	-5.0	<-62.0	<-67.0	-13.0	>54.0
13366.85	1.9	<-62.0	<-60.1	-13.0	>47.1
15276.40	-0.2	<-62.0	<-62.2	-13.0	>49.2
17185.95	10.6	<-62.0	<-51.4	-13.0	>38.4
19095.50	13.5	<-62.0	<-48.5	-13.0	>35.5



Test Port : ANT. 4 (Tx Frequency : 1880.15 MHz) 6.0 [ W ]

Measured Frequency [ MHz ]	Correction Factor (*) [ dB ]	Meter Reading [ dBm ]	Spurious Emission [ dBm ]	Limit (*2) [ dBm ]	Margin For Limit [ dB ]
[ Harmonics & Other Emission ]					
3760.30	24.5	-63.6	-39.1	-13.0	26.1
5640.45	26.1	<-68.0	<-41.9	-13.0	>28.9
7520.60	-8.0	-56.0	-64.0	-13.0	51.0
9400.75	-6.9	-52.3	-59.2	-13.0	46.2
11280.90	-4.9	-56.8	-61.7	-13.0	48.7
13161.05	12.0	<-62.0	<-50.0	-13.0	>37.0
15041.20	-1.5	<-62.0	<-63.5	-13.0	>50.5
16921.35	14.3	<-62.0	<-47.7	-13.0	>34.7
18801.50	13.0	<-62.0	<-49.0	-13.0	>36.0

Test Port : ANT. 4 (Tx Frequency : 1894.85 MHz) 6.0 [ W ]

Measured Frequency [ MHz ]	Correction Factor (*) [ dB ]	Meter Reading [ dBm ]	Spurious Emission [ dBm ]	Limit (*2) [ dBm ]	Margin For Limit [ dB ]
[ Harmonics & Other Emission ]					
3789.70	24.5	-62.4	-37.9	-13.0	24.9
5684.55	25.7	<-68.0	<-42.3	-13.0	>29.3
7579.40	-8.0	-55.3	-63.3	-13.0	50.3
9474.25	-6.8	-54.3	-61.1	-13.0	48.1
11369.10	-4.9	<-62.0	<-66.9	-13.0	>53.9
13263.95	5.4	<-62.0	<-56.6	-13.0	>43.6
15158.80	-1.4	<-62.0	<-63.4	-13.0	>50.4
17053.65	11.6	<-62.0	<-50.4	-13.0	>37.4
18948.50	13.9	<-62.0	<-48.1	-13.0	>35.1

- Continued -

Test Port : ANT. 4 (Tx Frequency : 1909.55 MHz) 6.2 [ W ]

Measured Frequency [ MHz ]	Correction Factor (*) [ dB ]	Meter Reading [ dBm ]	Spurious Emission [ dBm ]	Limit (*2) [ dBm ]	Margin For Limit [ dB ]
[ Harmonics & Other Emission ]					
3819.10	24.4	-64.0	-39.6	-13.0	26.6
5728.65	25.6	<-68.0	<-42.4	-13.0	>29.4
7638.20	-8.0	-54.0	-62.0	-13.0	49.0
9547.75	-7.0	-56.5	-63.5	-13.0	50.5
11457.30	-5.0	<-62.0	<-67.0	-13.0	>54.0
13366.85	1.9	<-62.0	<-60.1	-13.0	>47.1
15276.40	-0.2	<-62.0	<-62.2	-13.0	>49.2
17185.95	10.6	<-62.0	<-51.4	-13.0	>38.4
19095.50	13.5	<-62.0	<-48.5	-13.0	>35.5

<p>[Note]</p> <p>(1) No other spurious emission found above noise level.</p> <p>(2) (*) : Correction factor is included the cable loss and band eliminated filter insertion loss, pre-amplifier gain and attenuator loss.</p>
<p>[Calculation method (*2) ]</p> <p>Spurious RF Emission ( dBm ) = Meter Reading ( dBm ) + Correction Factor (dB)</p> <p>Calculation of the Limit.</p> <p>ex) ANT.1 RF Conducted Power : 6.2[W] = 37.9 [dBm]</p> <p>Limit Level = 37.9 [dBm] – (43 + 10log<sub>10</sub> (6.2))</p> <p>= -13.0 [dBm]</p> <p>Deviation From Margin for Limit [dB] = Limit level (dBm) – Spurious RF Emission (dBm)</p>
<p>[Test Condition]</p> <p>EUT operation : Op-mode 1, 2, 3, 4</p> <p>Output Ant. : 1 to 4</p>

[ Environment ]  
 Temperature 24°C Humidity 42%

[ Tested Date / Tester ]  
 28 May 2004

Signature   
 Ikuya Minematsu

## 6. TRANSMIT POWER (E. I. R. P) MEASUREMENT (§ 24.232)

### 6.1. Test Procedure

- (1) Place the transmitter to be tested (EUT) on the turntable.
- (2) Measurements shall be made from the lowest radio frequency generated in the equipment to the tenth harmonic of the carrier.
- (3) For each spurious frequency, raise and lower the test antenna from 1m to 4m to obtain a maximum reading on the spectrum analyzer (\*1) with the test antenna at horizontal polarity.  
Then the turntable should be rotated 360° to determine the maximum reading. Repeat this procedure to obtain the highest possible reading. Record this maximum reading.
- (4) Repeat step (3) for each spurious frequency with the test antenna polarized vertically.
- (5) Remove the transmitter and replace it with a substitution antenna (the antenna should be half-wavelength for each frequency involved). The center of the substitution antenna should be approximately at the same location as the center of the transmitter.  
At the lower frequencies, where the substitution antenna is very long, this will be impossible to achieve when the antenna is polarized vertically.  
In such case the lower end of the antenna should be 0.3m above the ground.
- (6) Feed the substitution antenna at the transmitter end with a signal generator connected to the antenna by means of a non-radiating cable.  
With the antennas at both ends horizontally polarized and with the signal generator tuned to a particular spurious frequency, raise and lower the test antenna to obtain a maximum reading at the spectrum analyzer. Adjust the level of the signal generator output until the previously recorded maximum reading for this set of conditions is obtained.  
This should be done carefully repeating the adjustment of the test antenna and generator output.
- (7) Repeat step (6) with both antennas vertically polarized for each spurious frequency.

[Note]

(\*1) Spectrum Analyzer Set Up Condition

Frequency Span	: 10 MHz
Resolution Bandwidth	: 1 MHz
Video Bandwidth	: $\geq$ RBW
Sweep time	: Auto

## 6.2. Test Results

Test Port : ANT. 1

ch.	Measured Frequency [ MHz ]	Meter Reading		Couple Factor (*) [ dB ]	Tx Antenna Gain [ dBi ]	Cable Loss [ dB ]	Maximum EIRP [ dBm ]	Maximum EIRP [ W ]	Limits [ W ]	Margin For Limits [ dB ]
		Horizontal Polarization [ dBm ]	Vertical Poarization [ dBm ]							
206	1880.15	2.7	21.6	14.5	13.1	2.8	46.4	43.7	1600.0	15.6
255	1894.85	2.3	22.0	14.5	13.4	2.8	47.1	51.3	1600.0	14.9
49	1909.55	3.0	21.9	14.5	13.7	2.8	47.3	53.7	1600.0	14.7

Test Port : ANT. 2

ch.	Measured Frequency [ MHz ]	Meter Reading		Couple Factor (*) [ dB ]	Tx Antenna Gain [ dBi ]	Cable Loss [ dB ]	Maximum EIRP [ dBm ]	Maximum EIRP [ W ]	Limits [ W ]	Margin For Limits [ dB ]
		Horizontal Polarization [ dBm ]	Vertical Poarization [ dBm ]							
206	1880.15	3.5	21.2	14.5	13.1	2.8	46.0	40.0	1600.0	16.0
255	1894.85	2.9	21.4	14.5	13.4	2.8	46.5	44.7	1600.0	15.5
49	1909.55	2.4	21.7	14.5	13.7	2.8	47.1	51.3	1600.0	14.9

Test Port : ANT. 3

ch.	Measured Frequency [ MHz ]	Meter Reading		Couple Factor (*) [ dB ]	Tx Antenna Gain [ dBi ]	Cable Loss [ dB ]	Maximum EIRP [ dBm ]	Maximum EIRP [ W ]	Limits [ W ]	Margin For Limits [ dB ]
		Horizontal Polarization [ dBm ]	Vertical Poarization [ dBm ]							
206	1880.15	3.4	21.4	14.5	13.1	2.8	46.2	41.7	1600.0	15.8
255	1894.85	2.7	21.5	14.5	13.4	2.8	46.6	45.7	1600.0	15.4
49	1909.55	2.5	21.2	14.5	13.7	2.8	46.6	45.7	1600.0	15.4

Test Port : ANT. 4

ch.	Measured Frequency [ MHz ]	Meter Reading		Couple Factor (*) [ dB ]	Tx Antenna Gain [ dBi ]	Cable Loss [ dB ]	Maximum EIRP [ dBm ]	Maximum EIRP [ W ]	Limits [ W ]	Margin For Limits [ dB ]
		Horizontal Polarization [ dBm ]	Vertical Poarization [ dBm ]							
206	1880.15	3.2	21.2	14.5	13.1	2.8	46.0	40.0	1600.0	16.0
255	1894.85	3.4	21.5	14.5	13.4	2.8	46.6	45.7	1600.0	15.4
49	1909.55	2.4	21.1	14.5	13.7	2.8	46.5	44.7	1600.0	15.5

- Continued -

[Note] (1) (*) Couple Factor is included both of coupling factor and insertion of the using coupling device. (2) No other spurious emission found above noise level.
[Calculation method] EIRP [dBm] : Meter Reading [dBm] + Couple Factor [dB] + Tx. Antenna Gain [dBi] – Cable loss [dB]
[Test Condition] EUT operation : Op-mode 1, 2, 3, 4 Output Ant. : 1 to 4

[ Environment ]

Temperature 24°C      Humidity 42%

[Tested Date / Tester]

26 May 2004

Signature



Ikuya Minematsu

### Maximum Permissible Exposure (MPE)

The Limit for Maximum Permissible Exposure (MPE) at frequency of 1894.85 MHz is 1.00 mW/cm<sup>2</sup>.  
(1.00 mW/cm<sup>2</sup> for General Population / Uncontrolled environment § 1.1310.)

The conversion from power to power density uses the following equation :

$$PD = (TP \times G) / 4 \pi r^2 = EIRP / 4 \pi r^2$$

$$r = \text{SQRT} (EIRP / 4 \pi PD)$$

Where : PD : Power Density at the Minimum Save-distance (W/m<sup>2</sup>)  
 TP : Transmitted Power (W)  
 G : Numeric gain of the antenna  
 EIRP : Equivalent Isotropic ally Radiated Power  
 r : Minimum Save-distance (in m)

The conversion from mW / cm<sup>2</sup> to W / m<sup>2</sup> is : 1mW/cm<sup>2</sup> = 10W /m<sup>2</sup> Maximum EIRP\*<sup>1</sup>

[Note] \*1 : Measured Value

Items	Value
EIRP (W)	53.7
PD (mW / cm <sup>2</sup> )	1.00
PD (W / m <sup>2</sup> )	10.00
r (m)	0.65

MPE evaluation

Minimum Save-distance : 0.65m

Theoretical EIRP calculation

This cell station transmits signals with Antenna selective diversity technology from one of the four antennas. The average transmission power per one antenna is maximum 500mW. As a result, the peak power becomes 4W.

[Calculation]

This cell station specifies its transmission output level by TDMA time-average of PHS. Since TDMA format of PHS is divided into 8 slots, transmission output of our cell station is described as below.

- Average output : 500mW/antenna : conducted RF
- Maximum peak output : 4W/antenna (500mW\*8 = 4W) : conducted RF

Also, we use the one which antenna gain is 10(9.45) dBi for this data.

Considering those 3 points described as above, the maximum EIRP is as indicated below.

$$4W * 8.8(=9.45dB) = 35.2W \quad : \text{EIRP}$$

Theoretically, output power level will be calculated as above.

In reality, output power level of the cell station is adjusted by the average value measured by power meter. In test report, peak value is measured by using Spectrum analyzer. As you know, a modulated signal has different output level in each second. Accordingly, it is obvious that there is some difference between average value and instantaneous value.

We know that the difference will be effected by spectrum analyzer setup. Inputting the modulated signal and CW wave into the spectrum analyzer, there was 2.1dB difference between those values.

Based on above, theoretical value should be calculated with measurement difference, it will be shown as follows.

- Maximum peak output :  $4W * 1.6(=2.1dB) = 6.4W$  : conducted RF
- $35.2W * 1.6(=2.1dB) = 56.3W$  : EIRP

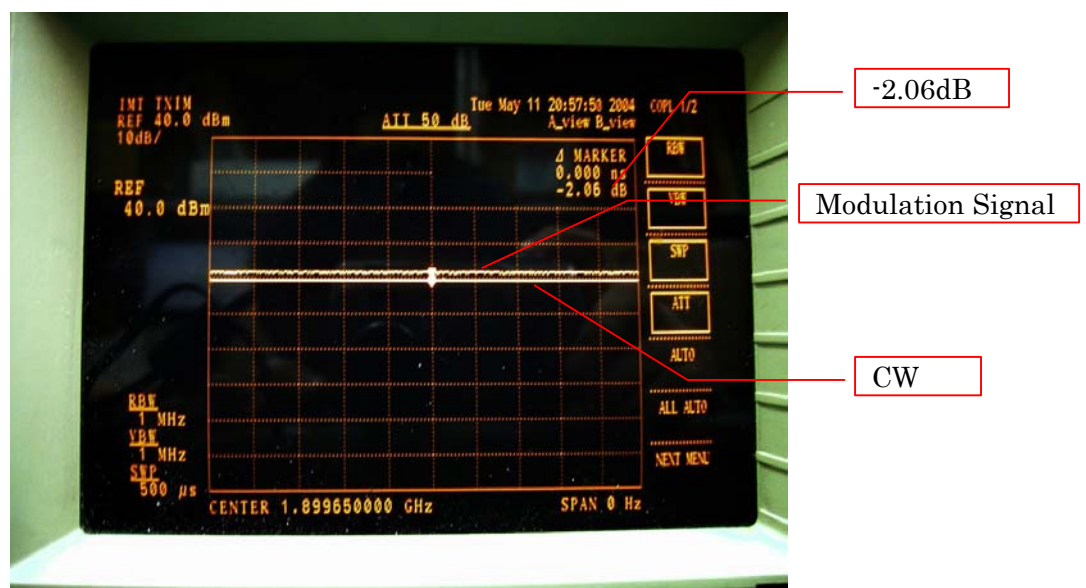

\*output power levels are : 20,32,50,80,125,200,315,500mW (average value of conducted RF) (increase by 2 dB)

## 7. RADIATED SPURIOUS (E. I. R. P) MEASUREMENT (§ 24.238)

### 7.1. Test Procedure

- (1) Place the transmitter to be tested (EUT) on the turntable.
- (2) Measurements shall be made from the lowest radio frequency generated in the equipment to the tenth harmonic of the carrier.
- (3) For each spurious frequency, raise and lower the test antenna from 1m to 4m to obtain a maximum reading on the spectrum analyzer (\*1) with the test antenna at horizontal polarity.  
Then the turntable should be rotated 360° to determine the maximum reading. Repeat this procedure to obtain the highest possible reading. Record this maximum reading.
- (4) Repeat step (3) for each spurious frequency with the test antenna polarized vertically.
- (5) Remove the transmitter and replace it with a substitution antenna (the antenna should be half-wavelength for each frequency involved). The center of the substitution antenna should be approximately at the same location as the center of the transmitter.  
At the lower frequencies, where the substitution antenna is very long, this will be impossible to achieve when the antenna is polarized vertically.  
In such case the lower end of the antenna should be 0.3m above the ground.
- (6) Feed the substitution antenna at the transmitter end with a signal generator connected to the antenna by means of a non-radiating cable.  
With the antennas at both ends horizontally polarized and with the signal generator tuned to a particular spurious frequency, raise and lower the test antenna to obtain a maximum reading at the spectrum analyzer. Adjust the level of the signal generator output until the previously recorded maximum reading for this set of conditions is obtained.  
This should be done carefully repeating the adjustment of the test antenna and generator output.
- (7) Repeat step (6) with both antennas vertically polarized for each spurious frequency.
- (8) The levels record in step (8) are the absolute levels of radiated spurious emissions in dBm. The radiated spurious emissions in dB can be calculated by the following:

[Note]

(\*1) Spectrum Analyzer Set Up Condition

Frequency Span	: 10 MHz
Resolution Bandwidth	: 1 MHz
Video Bandwidth	: $\geq$ RBW
Sweep time	: Auto



## 7.2. Test Results

Test Port : ANT.1 (Tx Frequency : 1880.15 MHz )

EIRP 43.7 [ W ]

Measured Frequency [ MHz ]	Meter Reading		Couple Factor (*) [ dB ]	Tx Antenna Gain [ dBi ]	Cable Loss [ dB ]	Maximum EIRP [ dBm ]	Limits (*1) [ dBm ]	Margin For Limits [ dB ]
	Horizontal Polarization [ dBm ]	Vertical Polarization [ dBm ]						
[ Harmonics & Other Emission ]								
3760.30	-81.4	-76.5	14.6	16.7	4.7	-49.9	-13.0	36.9
5640.45	<-77.6	<-75.3	14.3	19.1	5.7	<-47.6	-13.0	>34.6
7520.60	<-82.7	-80.9	19.9	22.3	6.6	-45.3	-13.0	32.3
9400.75	<-84.4	<-84.4	19.9	21.5	7.5	<-50.5	-13.0	>37.5
11280.90	<-80.8	<-80.6	19.8	21.8	8.3	<-47.3	-13.0	>34.3
13161.05	<-78.4	<-78.2	19.4	23.2	9.0	<-44.6	-13.0	>31.6
15041.20	<-74.7	<-74.6	17.2	24.1	9.6	<-42.9	-13.0	>29.9
16921.35	<-70.9	<-70.8	18.2	24.3	10.3	<-38.6	-13.0	>25.6
18801.50	<-66.8	<-66.8	18.9	23.0	10.8	<-35.7	-13.0	>22.7

Test Port : ANT.1 (Tx Frequency : 1894.85 MHz )

EIRP 51.3 [ W ]

Measured Frequency [ MHz ]	Meter Reading		Couple Factor (*) [ dB ]	Tx Antenna Gain [ dBi ]	Cable Loss [ dB ]	Maximum EIRP [ dBm ]	Limits (*1) [ dBm ]	Margin For Limits [ dB ]
	Horizontal Polarization [ dBm ]	Vertical Polarization [ dBm ]						
[ Harmonics & Other Emission ]								
3789.70	<-81.4	-77.2	14.6	16.7	4.7	-50.6	-13.0	37.6
5684.55	<-77.5	-75.4	14.3	19.1	5.7	-47.7	-13.0	34.7
7579.40	<-82.2	-79.8	19.9	22.3	6.7	-44.3	-13.0	31.3
9474.25	<-84.3	<-84.1	19.9	21.6	7.5	<-50.1	-13.0	>37.1
11369.10	<-80.1	<-80.1	19.8	21.8	8.3	<-46.8	-13.0	>33.8
13263.95	<-78.4	<-78.4	19.4	23.2	9.0	<-44.8	-13.0	>31.8
15158.80	<-74.8	<-74.7	16.5	24.1	9.6	<-43.7	-13.0	>30.7
17053.65	<-70.5	<-70.4	18.2	24.3	10.3	<-38.2	-13.0	>25.2
18948.50	<-66.7	<-66.5	18.9	23.1	10.9	<-35.4	-13.0	>22.4

- Continued -

Test Port : ANT.1 (Tx Frequency : 1909.55 MHz )

EIRP

53.7 [ W ]

Measured Frequency [ MHz ]	Meter Reading		Couple Factor (*) [ dB ]	Tx Antenna Gain [ dBi ]	Cable Loss [ dB ]	Maximum EIRP [ dBm ]	Limits (*1) [ dBm ]	Margin For Limits [ dB ]
	Horizontal Polarization [ dBm ]	Vertical Polarization [ dBm ]						
[ Harmonics & Other Emission ]								
3819.10	<-76.5	-66.7	14.6	16.8	4.7	-40.0	-13.0	27.0
5728.65	<-77.3	-75.1	14.3	19.2	5.7	-47.3	-13.0	34.3
7638.20	<-82.2	-80.8	19.9	22.4	6.7	-45.2	-13.0	32.2
9547.75	<-84.0	<-84.0	19.9	21.6	7.6	<-50.1	-13.0	>37.1
11457.30	<-79.5	<-79.2	19.8	21.8	8.3	<-45.9	-13.0	>32.9
13366.85	<-77.7	<-77.8	19.4	23.2	9.0	<-44.2	-13.0	>31.2
15276.40	<-74.9	<-74.7	15.8	24.0	9.6	<-44.5	-13.0	>31.5
17185.95	<-70.3	<-70.0	18.3	24.2	10.3	<-37.8	-13.0	>24.8
19095.50	<-66.7	<-66.7	18.9	23.1	10.9	<-35.6	-13.0	>22.6

Test Port : ANT.2 (Tx Frequency : 1880.15 MHz )

EIRP

40.0 [ W ]

Measured Frequency [ MHz ]	Meter Reading		Couple Factor (*) [ dB ]	Tx Antenna Gain [ dBi ]	Cable Loss [ dB ]	Maximum EIRP [ dBm ]	Limits (*1) [ dBm ]	Margin For Limits [ dB ]
	Horizontal Polarization [ dBm ]	Vertical Polarization [ dBm ]						
[ Harmonics & Other Emission ]								
3760.30	-81.4	-76.4	14.6	16.7	4.7	-49.8	-13.0	36.8
5640.45	<-77.6	<-77.9	14.3	19.1	5.7	<-49.9	-13.0	>36.9
7520.60	<-82.7	-79.6	19.9	22.3	6.6	-44.0	-13.0	31.0
9400.75	<-84.4	<-84.4	19.9	21.5	7.5	<-50.5	-13.0	>37.5
11280.90	<-80.8	<-80.6	19.8	21.8	8.3	<-47.3	-13.0	>34.3
13161.05	<-78.4	<-78.2	19.4	23.2	9.0	<-44.6	-13.0	>31.6
15041.20	<-74.7	<-74.6	17.2	24.1	9.6	<-42.9	-13.0	>29.9
16921.35	<-70.9	<-70.8	18.2	24.3	10.3	<-38.6	-13.0	>25.6
18801.50	<-66.8	<-66.8	18.9	23.0	10.8	<-35.7	-13.0	>22.7

Test Port : ANT.2 (Tx Frequency : 1894.85 MHz )

EIRP

44.7 [ W ]

Measured Frequency [ MHz ]	Meter Reading		Couple Factor (*) [ dB ]	Tx Antenna Gain [ dBi ]	Cable Loss [ dB ]	Maximum EIRP [ dBm ]	Limits (*1) [ dBm ]	Margin For Limits [ dB ]
	Horizontal Polarization [ dBm ]	Vertical Polarization [ dBm ]						
[ Harmonics & Other Emission ]								
3789.70	-81.4	-76.5	14.6	16.7	4.7	-49.9	-13.0	36.9
5684.55	<-77.5	-76.2	14.3	19.1	5.7	-48.5	-13.0	35.5
7579.40	<-82.2	-80.2	19.9	22.3	6.7	-44.7	-13.0	31.7
9474.25	<-84.3	<-84.1	19.9	21.6	7.5	<-50.1	-13.0	>37.1
11369.10	<-80.1	<-80.1	19.8	21.8	8.3	<-46.8	-13.0	>33.8
13263.95	<-78.4	<-78.4	19.4	23.2	9.0	<-44.8	-13.0	>31.8
15158.80	<-74.8	<-74.7	16.5	24.1	9.6	<-43.7	-13.0	>30.7
17053.65	<-70.5	<-70.4	18.2	24.3	10.3	<-38.2	-13.0	>25.2
18948.50	<-66.7	<-66.5	18.9	23.1	10.9	<-35.4	-13.0	>22.4

- Continued -

Test Port : ANT.2 (Tx Frequency : 1909.55 MHz )

EIRP

51.3 [ W ]

Measured Frequency [ MHz ]	Meter Reading		Couple Factor (*) [ dB ]	Tx Antenna Gain [ dBi ]	Cable Loss [ dB ]	Maximum EIRP [ dBm ]	Limits (*1) [ dBm ]	Margin For Limits [ dB ]
	Horizontal Polarization [ dBm ]	Vertical Polarization [ dBm ]						
[ Harmonics & Other Emission ]								
3819.10	-77.7	-65.0	14.6	16.7	4.7	-38.4	-13.0	25.4
5728.65	<-77.3	-75.9	14.3	19.1	5.7	-48.2	-13.0	35.2
7638.20	<-82.2	-80.9	19.9	22.3	6.6	<-45.3	-13.0	>32.3
9547.75	<-84.4	<-84.4	19.9	21.5	7.5	<-50.5	-13.0	>37.5
11457.30	<-80.8	<-80.6	19.8	21.8	8.3	<-47.3	-13.0	>34.3
13366.85	<-78.4	<-78.2	19.4	23.2	9.0	<-44.6	-13.0	>31.6
15276.40	<-74.7	<-74.6	17.2	24.1	9.6	<-42.9	-13.0	>29.9
17185.95	<-70.9	<-70.8	18.2	24.3	10.3	<-38.6	-13.0	>25.6
19095.50	<-66.8	<-66.8	18.9	23.0	10.8	<-35.7	-13.0	>22.7

Test Port : ANT.3 (Tx Frequency : 1880.15 MHz )

EIRP

41.7 [ W ]

Measured Frequency [ MHz ]	Meter Reading		Couple Factor (*) [ dB ]	Tx Antenna Gain [ dBi ]	Cable Loss [ dB ]	Maximum EIRP [ dBm ]	Limits (*1) [ dBm ]	Margin For Limits [ dB ]
	Horizontal Polarization [ dBm ]	Vertical Polarization [ dBm ]						
[ Harmonics & Other Emission ]								
3760.30	-81.4	-75.1	14.6	16.7	4.7	-48.5	-13.0	35.5
5640.45	<-77.6	<-77.9	14.3	19.1	5.7	<-49.9	-13.0	>36.9
7520.60	<-82.7	-80.4	19.9	22.3	6.6	-44.8	-13.0	31.8
9400.75	<-84.4	<-84.4	19.9	21.5	7.5	<-50.5	-13.0	>37.5
11280.90	<-80.8	<-80.6	19.8	21.8	8.3	<-47.3	-13.0	>34.3
13161.05	<-78.4	<-78.2	19.4	23.2	9.0	<-44.6	-13.0	>31.6
15041.20	<-74.7	<-74.6	17.2	24.1	9.6	<-42.9	-13.0	>29.9
16921.35	<-70.9	<-70.8	18.2	24.3	10.3	<-38.6	-13.0	>25.6
18801.50	<-66.8	<-66.8	18.9	23.0	10.8	<-35.7	-13.0	>22.7

Test Port : ANT.3 (Tx Frequency : 1894.85 MHz )

EIRP

45.7 [ W ]

Measured Frequency [ MHz ]	Meter Reading		Couple Factor (*) [ dB ]	Tx Antenna Gain [ dBi ]	Cable Loss [ dB ]	Maximum EIRP [ dBm ]	Limits (*1) [ dBm ]	Margin For Limits [ dB ]
	Horizontal Polarization [ dBm ]	Vertical Polarization [ dBm ]						
[ Harmonics & Other Emission ]								
3789.70	-81.4	-73.6	14.6	16.7	4.7	-47.0	-13.0	34.0
5684.55	<-77.5	-76.6	14.3	19.1	5.7	-48.9	-13.0	35.9
7579.40	<-82.2	-78.9	19.9	22.3	6.7	-43.4	-13.0	30.4
9474.25	<-84.3	<-84.1	19.9	21.6	7.5	<-50.1	-13.0	>37.1
11369.10	<-80.1	<-80.1	19.8	21.8	8.3	<-46.8	-13.0	>33.8
13263.95	<-78.4	<-78.4	19.4	23.2	9.0	<-44.8	-13.0	>31.8
15158.80	<-74.8	<-74.7	16.5	24.1	9.6	<-43.7	-13.0	>30.7
17053.65	<-70.5	<-70.4	18.2	24.3	10.3	<-38.2	-13.0	>25.2
18948.50	<-66.7	<-66.5	18.9	23.1	10.9	<-35.4	-13.0	>22.4

- Continued -

Test Port : ANT.3 (Tx Frequency : 1909.55 MHz )

EIRP

45.7 [ W ]

Measured Frequency [ MHz ]	Meter Reading		Couple Factor (*) [ dB ]	Tx Antenna Gain [ dBi ]	Cable Loss [ dB ]	Maximum EIRP [ dBm ]	Limits (*1) [ dBm ]	Margin For Limits [ dB ]
	Horizontal Polarization [ dBm ]	Vertical Polarization [ dBm ]						
[ Harmonics & Other Emission ]								
3819.10	-77.1	-67.5	14.6	16.7	4.7	-40.9	-13.0	27.9
5728.65	<-77.3	-74.8	14.3	19.1	5.7	-47.1	-13.0	34.1
7638.20	<-82.2	-80.5	19.9	22.3	6.6	-44.9	-13.0	31.9
9547.75	<-84.4	<-84.4	19.9	21.5	7.5	<-50.5	-13.0	>37.5
11457.30	<-80.8	<-80.6	19.8	21.8	8.3	<-47.3	-13.0	>34.3
13366.85	<-78.4	<-78.2	19.4	23.2	9.0	<-44.6	-13.0	>31.6
15276.40	<-74.7	<-74.6	17.2	24.1	9.6	<-42.9	-13.0	>29.9
17185.95	<-70.9	<-70.8	18.2	24.3	10.3	<-38.6	-13.0	>25.6
19095.50	<-66.8	<-66.8	18.9	23.0	10.8	<-35.7	-13.0	>22.7

Test Port : ANT.4 (Tx Frequency : 1880.15 MHz )

EIRP 40.0 [ W ]

Measured Frequency [ MHz ]	Meter Reading		Couple Factor (*) [ dB ]	Tx Antenna Gain [ dBi ]	Cable Loss [ dB ]	Maximum EIRP [ dBm ]	Limits (*1) [ dBm ]	Margin For Limits [ dB ]
	Horizontal Polarization [ dBm ]	Vertical Polarization [ dBm ]						
[ Harmonics & Other Emission ]								
3760.30	-81.4	-76.6	14.6	16.7	4.7	-50.0	-13.0	37.0
5640.45	<-77.6	-77.9	14.3	19.1	5.7	<-49.9	-13.0	>36.9
7520.60	<-82.7	-81.4	19.9	22.3	6.6	-45.8	-13.0	32.8
9400.75	<-84.4	<-84.4	19.9	21.5	7.5	<-50.5	-13.0	>37.5
11280.90	<-80.8	<-80.6	19.8	21.8	8.3	<-47.3	-13.0	>34.3
13161.05	<-78.4	<-78.2	19.4	23.2	9.0	<-44.6	-13.0	>31.6
15041.20	<-74.7	<-74.6	17.2	24.1	9.6	<-42.9	-13.0	>29.9
16921.35	<-70.9	<-70.8	18.2	24.3	10.3	<-38.6	-13.0	>25.6
18801.50	<-66.8	<-66.8	18.9	23.0	10.8	<-35.7	-13.0	>22.7

Test Port : ANT.4 (Tx Frequency : 1894.85 MHz )

EIRP 45.7 [ W ]

Measured Frequency [ MHz ]	Meter Reading		Couple Factor (*) [ dB ]	Tx Antenna Gain [ dBi ]	Cable Loss [ dB ]	Maximum EIRP [ dBm ]	Limits (*1) [ dBm ]	Margin For Limits [ dB ]
	Horizontal Polarization [ dBm ]	Vertical Polarization [ dBm ]						
[ Harmonics & Other Emission ]								
3789.70	-81.4	-72.8	14.6	16.7	4.7	-46.2	-13.0	33.2
5684.55	<-77.5	-76.6	14.3	19.1	5.7	-48.9	-13.0	35.9
7579.40	<-82.2	-79.7	19.9	22.3	6.7	-44.2	-13.0	31.2
9474.25	<-84.3	<-84.1	19.9	21.6	7.5	<-50.1	-13.0	>37.1
11369.10	<-80.1	<-80.1	19.8	21.8	8.3	<-46.8	-13.0	>33.8
13263.95	<-78.4	<-78.4	19.4	23.2	9.0	<-44.8	-13.0	>31.8
15158.80	<-74.8	<-74.7	16.5	24.1	9.6	<-43.7	-13.0	>30.7
17053.65	<-70.5	<-70.4	18.2	24.3	10.3	<-38.2	-13.0	>25.2
18948.50	<-66.7	<-66.5	18.9	23.1	10.9	<-35.4	-13.0	>22.4

- Continued -

Test Port : ANT.4 (Tx Frequency : 1909.55 MHz )

EIRP

44.7 [ W ]

Measured Frequency [ MHz ]	Meter Reading		Couple Factor (*) [ dB ]	Tx Antenna Gain [ dBi ]	Cable Loss [ dB ]	Maximum EIRP [ dBm ]	Limits (*1) [ dBm ]	Margin For Limits [ dB ]
	Horizontal Polarization [ dBm ]	Vertical Polarization [ dBm ]						
[ Harmonics & Other Emission ]								
3819.10	-74.3	-64.4	14.6	16.7	4.7	-37.8	-13.0	24.8
5728.65	<-77.3	-75.3	14.3	19.1	5.7	-47.6	-13.0	34.6
7638.20	<-82.2	-82.1	19.9	22.3	6.6	-46.5	-13.0	33.5
9547.75	<-84.4	<-84.4	19.9	21.5	7.5	<-50.5	-13.0	>37.5
11457.30	<-80.8	<-80.6	19.8	21.8	8.3	<-47.3	-13.0	>34.3
13366.85	<-78.4	<-78.2	19.4	23.2	9.0	<-44.6	-13.0	>31.6
15276.40	<-74.7	<-74.6	17.2	24.1	9.6	<-42.9	-13.0	>29.9
17185.95	<-70.9	<-70.8	18.2	24.3	10.3	<-38.6	-13.0	>25.6
19095.50	<-66.8	<-66.8	18.9	23.0	10.8	<-35.7	-13.0	>22.7

[Note]

(1) (\*) Couple Factor is included both of coupling factor and insertion of the using coupling device.

(2) No other spurious emission found above noise level.

[Calculation method]

EIRP [dBm] : Meter Reading [dBm] + Couple Factor [dB] + Tx. Antenna Gain [dBi] – Cable loss [dB]

Calculation of the limit

ex) ANT.1 EIRP at 1880.15 MHz, 47.9 [W] (= 46.8 [dBm] )

Limit level = 46.8 [dBm] – (43+10log<sub>10</sub> (60.3))  
= -13.0 [dBm]

[Test Condition]

EUT operation : Op-mode 1, 2, 3, 4

Output Ant. : 1 to 4

[ Environment ]

Temperature 24°C

Humidity 42%

[Tested Date / Tester]

27 May 2004

Signature



Ikuya Minematsu



## 8. OCCUPIED BANDWIDTH MEASUREMENT (§ 2.1049, §24.238)

### 8.1. Test Procedure

(1)	Connect the EUT RF output port to spectrum analyzer via calibrated coaxial cable and suitable attenuator (if necessary).
(2)	Activates the EUT System and execute the software prepared for test, if necessary.
(3)	To find out the maximum emission condition, the transmitting data rate of EUT is set to maximum data rate.
(4)	The Spectrums are scanned and allow the trace stabilized.
(5)	The both side of 26dB down value from peak power were measured by using delta-maker function of the spectrum analyzer (*1).
(6)	Above measurement were performed under low-band frequency, mid-band frequency and high band frequency.
[Note]	
(*1)	Spectrum Analyzer Set Up Conditions
	Frequency Span : 1 MHz
	Resolution bandwidth : 10 kHz
	Video bandwidth : more than RBW
	Sweep : Auto
	Detector function : Peak
	Trace Mode : Max Hold

### 8.2. Test Results

Test Port : ANT. 1

	Measured Frequency	26dB Bandwidth
ch.	[ MHz ]	[ kHz ]
206	1880.15	290.0
255	1894.85	285.0
49	1909.55	290.0

Test Port : ANT. 2

	Measured Frequency	26dB Bandwidth
ch.	[ MHz ]	[ kHz ]
206	1880.15	285.0
255	1894.85	290.0
49	1909.55	290.0

- Continued -

Test Port : ANT. 3

	Measured Frequency	26dB Bandwidth
ch.	[ MHz ]	[ kHz ]
206	1880.15	290.0
255	1894.85	290.0
49	1909.55	290.0

Test Port : ANT. 4

	Measured Frequency	26dB Bandwidth
ch.	[ MHz ]	[ kHz ]
206	1880.15	290.0
255	1894.85	290.0
49	1909.55	290.0

[Note] See next page figure 3 to 5.(Sample figure, output Ant. 1)
[Test Condition] EUT operation : Op-mode 1, 2, 3, 4 Output Ant. : 1 to 4

[ Environment ]

Temperature 24°C Humidity 42%

[ Tested Date / Tester ]

28 May 2004

Signature



Ikuya Minematsu



figure 3 26dB Bandwidth  $f_c = 1880.15$  MHz

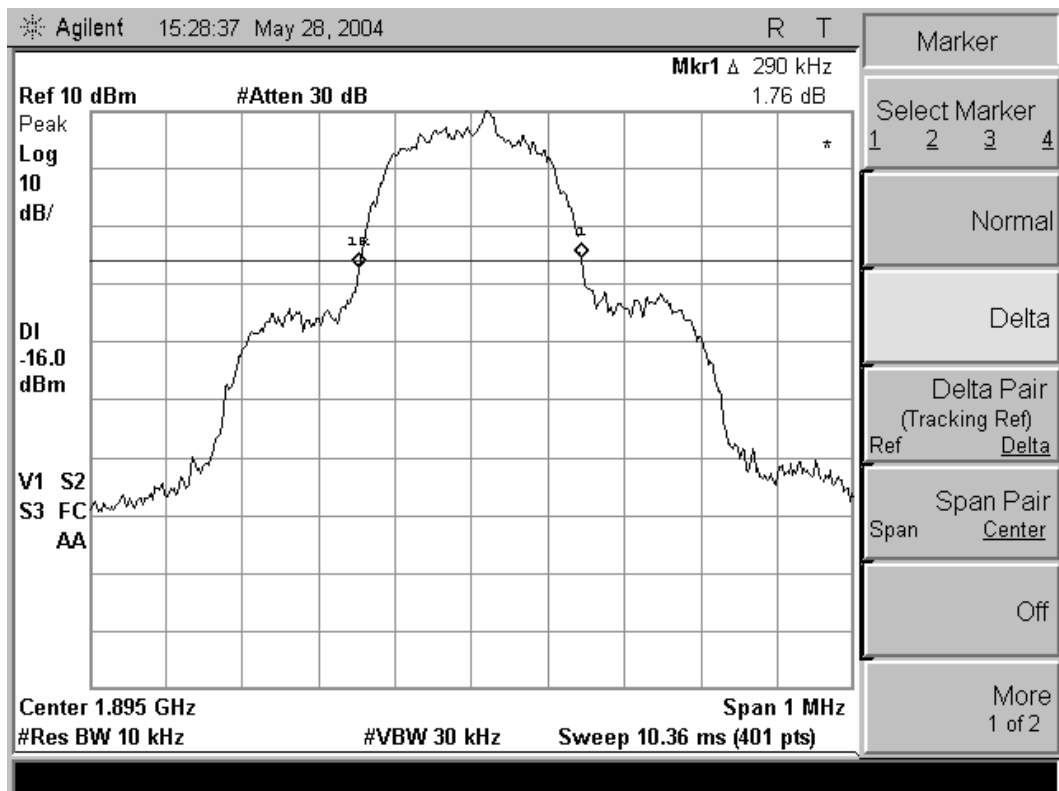

figure 4 26dB Bandwidth  $f_c = 1894.85$  MHz

- Continued -

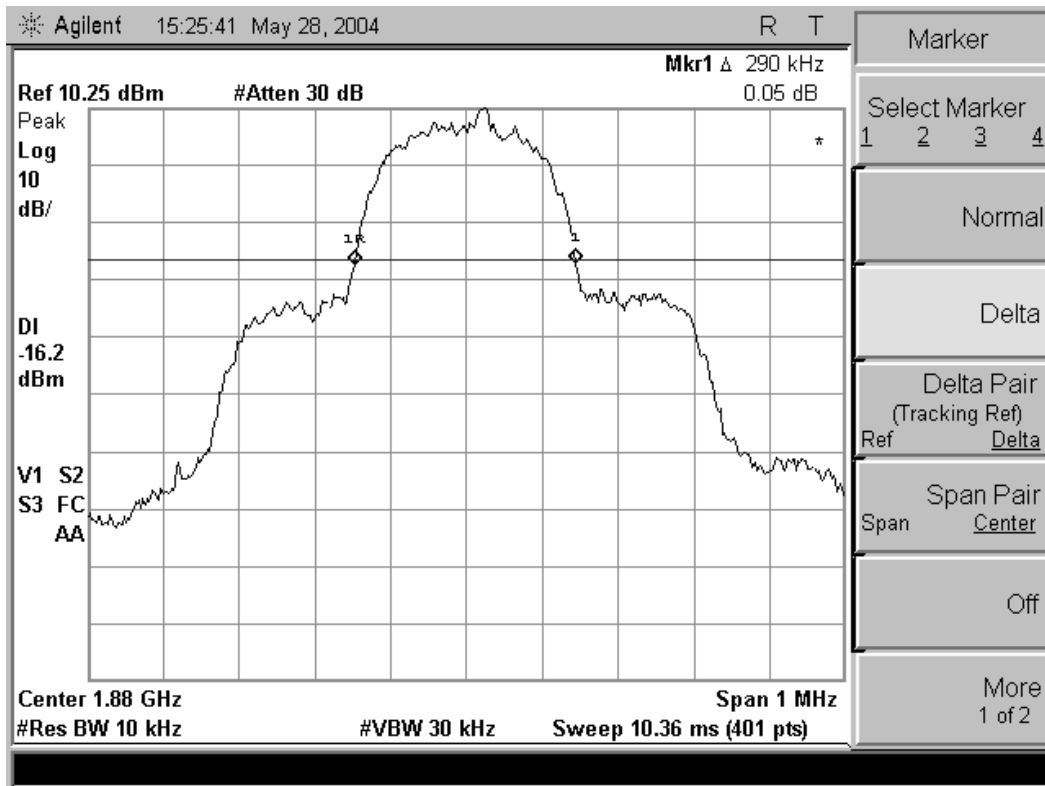

figure 5 26dB Bandwidth  $f_c = 1909.55$  MHz

## 9. BAND EDGE RF CONDUCTED EMISSION MEASUREMENT (§ 24.238)

### 9.1. Test Procedure

- |   |   |
|---|---|
| <ul style="list-style-type: none"> <li>(1)</li> <li>(2)</li> <li>(3)</li> <li>(4)</li> <li>(5)</li> <li>(6)</li> <li>(7)</li> </ul> | <p>Connect the EUT RF output port to the spectrum analyzer via calibrated coaxial cable and suitable attenuator (if necessary).</p> <p>Activates the EUT System and executes the software prepared for test, if necessary.</p> <p>To find out the maximum emission condition, the transmitting data rate of EUT is set to maximum data rate.</p> <p>The spectrum are scanned.</p> <p>The emission at the band edge or the highest modulation product outside of band were measured by using the marker function of spectrum analyzer (*1).</p> <p>The peak of the in-band emission were measured by using the marker to peak function of spectrum analyzer.</p> <p>Above measurement were repeated at other side band edge.</p> |
|---|---|

[Note]

(*1)	<p>Spectrum Analyzer Set Up Conditions</p> <p>Frequency Span : Wide enough to capture the peak level of emission on the closest to the band edge</p> <p>Band Edge Frequency : 1870.0 MHz / 1910.0 MHz</p> <p>Resolution bandwidth : 3 kHz</p> <p>Video bandwidth : More than RBW</p> <p>Sweep : Auto</p> <p>Detector function : Peak</p> <p>Trace Mode : Max Hold</p>
------	---

## 9.2. Test Results

Test Port : ANT. 1

	Transmitting Frequency	Band Edge Frequency	Attenuation From Carrier Level	Note
ch.	[ MHz ]	[ MHz ]	[ dBc ]	
206	1880.15	1870.0	<-68.0	(*2)
49	1909.55	1910.0	-61.4	(*3)

Test Port : ANT. 2

	Transmitting Frequency	Band Edge Frequency	Attenuation From Carrier Level	Note
ch.	[ MHz ]	[ MHz ]	[ dBc ]	
206	1880.15	1870.0	<-68.0	(*2)
49	1909.55	1910.0	-58.4	(*3)

Test Port : ANT. 3

	Transmitting Frequency	Band Edge Frequency	Attenuation From Carrier Level	Note
ch.	[ MHz ]	[ MHz ]	[ dBc ]	
206	1880.15	1870.0	<-68.0	(*2)
49	1909.55	1910.0	-59.8	(*3)

- Continued -

Test Port : ANT. 4

ch.	Transmitting Frequency [ MHz ]	Band Edge Frequency [ MHz ]	Attenuation From Carrier Level [ dBc ]	Note
206	1880.15	1870.0	<-68.0	(*2)
49	1909.55	1910.0	-57.1	(*3)

[Note]

(1) See next page figure 6, 7.

(2) (\*2) : Lower channel, (\*3) : Higher channel

[Test Condition]

EUT operation : Op-mode 1, 2, 3

Output Ant. : 1 to 4

[ Environment ]

Temperature 24°C Humidity 42%

[ Tested Date / Tester ]

28 May 2004

Signature



Ikuya Minematsu

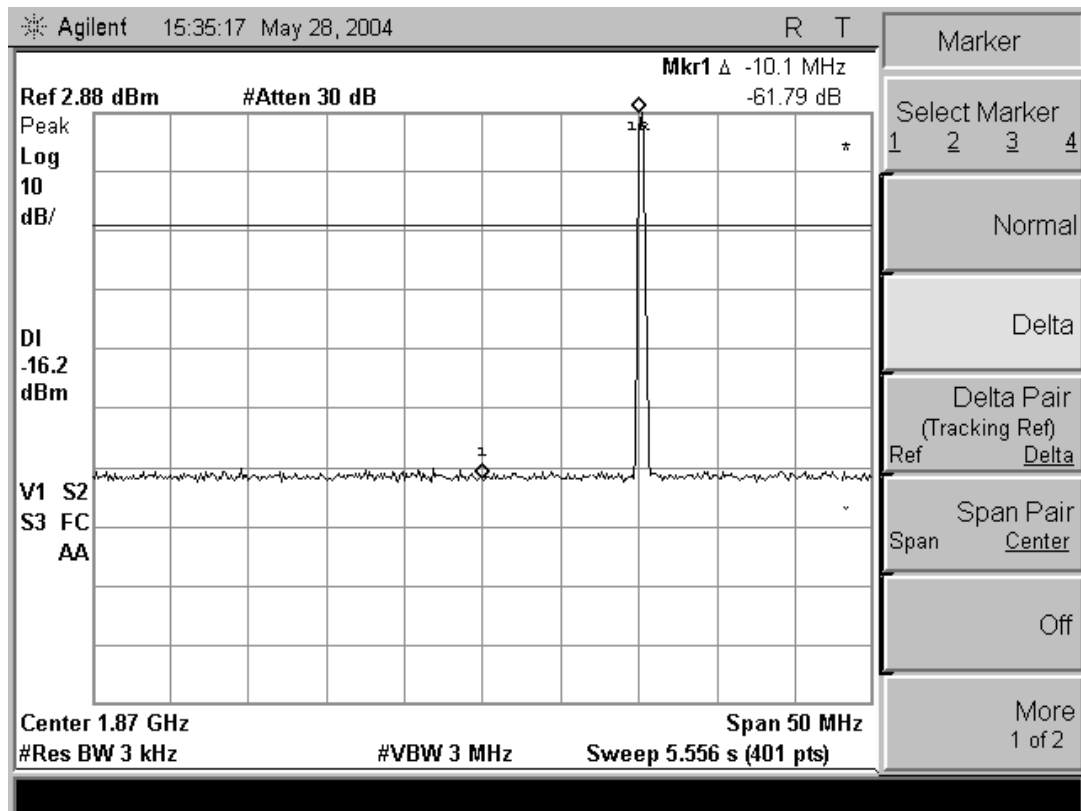

figure 6 Band Edge Low frequency side

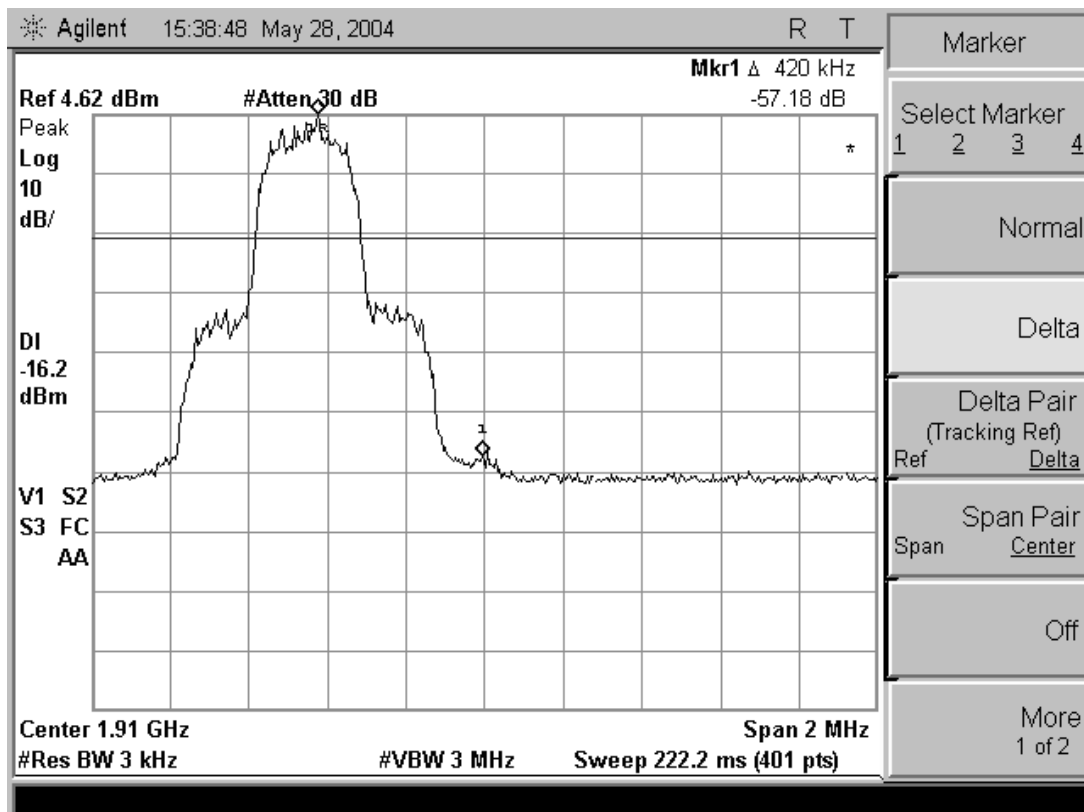

figure 7 Band Edge High frequency side



10. FREQUENCY STABILITY MEASUREMENT (§ 2.1055, § 24.235)

10.1. Test Procedure

(a)	<p>Frequency Stability Measurement versus Temperature</p> <p>The EUT was placed in an environmental chamber and was tested in the range from -30 to +50 degrees Celsius. The EUT was stabilized at each temperature. The power (120VAC) supplied was applied to the transmitter and allowed to stabilize for 10 minutes after startup. This procedure was repeated from -30 to +50 degrees Celsius at the interval of 10 degrees.</p>
(b)	<p>Frequency Stability Measurement versus Temperature</p> <p>The EUT was placed in an environmental chamber and was tested at the temperature of +20 degrees Celsius. The EUT was stabilized at the temperature. The power (120VAC), the power (102VAC, 85%) and the power (138VAC, 115%) was applied to the EUT allowed to stabilize for 10 minutes. The transmitting frequency was measured at startup and 2 minutes, 5 minutes and 10 minutes after startup.</p>

10.2. Test Results

Test Port Ant. 1 Test Voltage : AC120V

REFERENCE FREQUENCY [ MHz ]	TEMPERATURE [ °C ]	FREQUENCY DRIFT Start up [ % ]	FREQUENCY DRIFT 2 minutes [ % ]	FREQUENCY DRIFT 5minutes [ % ]	FREQUENCY DRIFT 10minutes [ % ]	LIMIT [ % ]
1880.15	-20	0.000064	0.000064	0.000064	0.000064	-
	-10	0.000048	0.000048	0.000048	0.000048	
	0	0.000016	0.000016	0.000016	0.000016	
	+10	-0.000026	-0.000025	-0.000026	-0.000025	
	+20	-0.000049	-0.000048	-0.000049	-0.000049	
	+30	-0.000070	-0.000072	-0.000074	-0.000074	
	+40	-0.000069	-0.000068	-0.000068	-0.000069	
	+50	-0.000032	-0.000032	-0.000032	-0.000032	

Temperature : 20°C

REFERENCE FREQUENCY [ MHz ]	SUPPLIED VOLTAGE Lower [ Volt ]	FREQUENCY DRIFT Start up [ % ]	FREQUENCY DRIFT 2 minutes [ % ]	FREQUENCY DRIFT 5minutes [ % ]	FREQUENCY DRIFT 10minutes [ % ]	LIMIT [ % ]
1880.15	102.0	-0.000049	-0.000049	-0.000049	-0.000049	-

Temperature : 20°C

REFERENCE FREQUENCY [ MHz ]	SUPPLIED VOLTAGE Upper [ Volt ]	FREQUENCY DRIFT Start up [ % ]	FREQUENCY DRIFT 2 minutes [ % ]	FREQUENCY DRIFT 5minutes [ % ]	FREQUENCY DRIFT 10minutes [ % ]	LIMIT [ % ]
1880.15	138.0	-0.000049	-0.000049	-0.000050	-0.000050	-

- Continued -

Test Port Ant. 1 Test Voltage : AC120V

REFERENCE FREQUENCY [ MHz ]	TEMPERATURE [ °C ]	FREQUENCY DRIFT Start up [ % ]	FREQUENCY DRIFT 2 minutes [ % ]	FREQUENCY DRIFT 5minites [ % ]	FREQUENCY DRIFT 10minutes [ % ]	LIMIT [ % ]
1894.85	-20	0.000064	0.000063	0.000064	0.000064	-
	-10	0.000048	0.000047	0.000048	0.000047	
	0	0.000015	0.000015	0.000015	0.000015	
	+10	-0.000028	-0.000027	-0.000027	-0.000026	
	+20	-0.000050	-0.000051	-0.000051	-0.000051	
	+30	-0.000074	-0.000074	-0.000074	-0.000074	
	+40	-0.000068	-0.000069	-0.000069	-0.000069	
	+50	-0.000032	-0.000032	-0.000032	-0.000032	

Temperature : 20°C

REFERENCE FREQUENCY [ MHz ]	SUPPLIED VOLTAGE Lower [ Volt ]	FREQUENCY DRIFT Start up [ % ]	FREQUENCY DRIFT 2 minutes [ % ]	FREQUENCY DRIFT 5minites [ % ]	FREQUENCY DRIFT 10minutes [ % ]	LIMIT [ % ]
1894.85	102.0	-0.000050	-0.000050	-0.000050	-0.000050	-

Temperature : 20°C

REFERENCE FREQUENCY [ MHz ]	SUPPLIED VOLTAGE Upper [ Volt ]	FREQUENCY DRIFT Start up [ % ]	FREQUENCY DRIFT 2 minutes [ % ]	FREQUENCY DRIFT 5minites [ % ]	FREQUENCY DRIFT 10minutes [ % ]	LIMIT [ % ]
1894.85	138.0	-0.000051	-0.000051	-0.000051	-0.000051	-

Test Port Ant. 1 Test Voltage : AC120V

REFERENCE FREQUENCY [ MHz ]	TEMPERATURE [ °C ]	FREQUENCY DRIFT Start up [ % ]	FREQUENCY DRIFT 2 minutes [ % ]	FREQUENCY DRIFT 5minites [ % ]	FREQUENCY DRIFT 10minutes [ % ]	LIMIT [ % ]
1909.55	-20	0.000063	0.000064	0.000064	0.000064	-
	-10	0.000047	0.000048	0.000048	0.000048	
	0	0.000015	0.000015	0.000015	0.000015	
	+10	-0.000029	-0.000029	-0.000028	-0.000028	
	+20	-0.000051	-0.000051	-0.000051	-0.000051	
	+30	-0.000074	-0.000074	-0.000074	-0.000074	
	+40	-0.000068	-0.000068	-0.000069	-0.000068	
	+50	-0.000033	-0.000033	-0.000033	-0.000033	

Temperature : 20°C

REFERENCE FREQUENCY [ MHz ]	SUPPLIED VOLTAGE Lower [ Volt ]	FREQUENCY DRIFT Start up [ % ]	FREQUENCY DRIFT 2 minutes [ % ]	FREQUENCY DRIFT 5minites [ % ]	FREQUENCY DRIFT 10minutes [ % ]	LIMIT [ % ]
1909.55	102.0	-0.000051	-0.000051	-0.000051	-0.000051	-

Temperature : 20°C

REFERENCE FREQUENCY [ MHz ]	SUPPLIED VOLTAGE Upper [ Volt ]	FREQUENCY DRIFT Start up [ % ]	FREQUENCY DRIFT 2 minutes [ % ]	FREQUENCY DRIFT 5minites [ % ]	FREQUENCY DRIFT 10minutes [ % ]	LIMIT [ % ]
1909.55	138.0	-0.000051	-0.000051	-0.000052	-0.000052	-

- Continued -

[Test Condition]	
EUT operation	: Op-mode 1, 2, 3
Output Ant.	: 1

[Environment]

Temperature: 25°C

Humidity: 60 %

[Tested Date/ Tester]

31 May – 2 June 2004

Signature



Ikuya Minematsu

## 11. RADIATED EMISSION MEASUREMENT (§ 15.247 c1)

## 11.1. Test Procedure

<p>(1) Configure the EUT System in accordance with ANSI C63.4-2001 section 8.  <input checked="" type="checkbox"/>: without deviation, <input type="checkbox"/>: with deviation (details are found below)  See also the block diagram and the photographs of EUT System configuration in this report.</p> <p>(2) If the EUT system is connected to a public power network, all power cords for the EUT System are connected the receptacle on the turntable.</p> <p>(3) Warm up the EUT System.</p> <p>(4) Activate the EUT System and run the prepared software for the test, if necessary.</p> <p>(5) Preliminary Measurement.  To find out the emissions of the EUT System, preliminary radiated measurement are performed at a closer distance than that specified for final radiated measurement using the spectrum analyzer (*1) with pre-amplifier and the broad band antenna.  In the frequency above 1 GHz, it is performed using the spectrum analyzer (*2) and the horn antenna.</p> <p>(6) To find out an EUT System condition, which produces the maximum emission, the configuration of EUT System, the position of the cables, and the operation mode, are changed under normal usage of the EUT.</p> <p>(7) The spectrums are scanned from 30 MHz to the upper frequency of measurement range with rotated the turn table from 0 to 360 degree, and collect the six highest emissions minimum on the spectrum analyzer relative to the limits in the whole range.</p> <p>(8) Final Measurement.  The EUT is operated in the worst case condition where maximum emission is detected by the preliminary test. The six highest emissions minimum, recorded above, are measured at the specified distance using the broad band antenna or the tuned dipole antenna and the test receiver (*3). In the frequency above 1 GHz, the measurements are performed by the horn antenna and <input type="checkbox"/> the test receiver (*4).  <input checked="" type="checkbox"/> the spectrum analyzer (*2) or (*5) with pre-amplifier.</p> <p>(9) So that maximum field strength, the turntable azimuth and receiving antenna are adjusted the position.</p>	<p>[Note]</p> <p>(*1) Spectrum Analyzer Set Up Conditions  Frequency range : 30 - 1000 MHz  Resolution bandwidth : 100 kHz  Detector function : Peak mode</p> <p>(*2) Spectrum Analyzer Set Up Conditions (Peak detector Measurement)  Frequency range : 1 GHz - Upper frequency of measurement range  Resolution bandwidth : 1 MHz  Video bandwidth : 1 MHz  Attenuator : 10 dB  Detector function : Peak mode</p> <p>(*3) Test Receiver Set Up Conditions  Detector function : Quasi-Peak  IF bandwidth : 120 kHz  The test receiver is complied with the specification of CISPR Publication 16.</p> <p>(*4) Test Receiver Set Up Conditions  Detector function : Average  IF bandwidth : 1 MHz</p> <p>(*5) Spectrum Analyzer Set Up Conditions (Average detector Measurement)  Frequency range : 1 GHz - Upper frequency of measurement range  Resolution bandwidth : 1 MHz  Video bandwidth : 10 Hz or 30 Hz  Attenuator : 10 dB  Y axis : Liner</p>
---	--

## 11.2. Test Results

(1) In the frequency range : above 1 GHz

Measurement Distance : 3m : 10m

Measured Frequency ( MHz )	Antenna Factor ( dB/m )	Cable Loss ( dB )	AMP Gain Correctio ( dB )	Meter Reading		Maximum Field Strength ( dB $\mu$ V/m )	Limits ( dB $\mu$ V/m )	Margin for Limits ( dB )
				Horizontal Polarization ( dB $\mu$ V )	Vertical Polarization ( dB $\mu$ V )			
1636.20	20.5	3.2	-36.2	<45.0	49.4	36.9	54.0	17.1
1650.90	20.5	3.2	-36.2	48.7	51.6	39.1	54.0	14.9
1665.60	20.6	3.2	-36.2	<45.0	48.4	36.0	54.0	18.0
3272.40	21.4	4.6	-34.8	<45.0	<45.0	<36.2	54.0	>17.8
3301.80	21.5	4.6	-34.8	<45.0	<45.0	<36.3	54.0	>17.7
3331.20	21.5	4.6	-34.8	<45.0	46.8	38.1	54.0	15.9
4908.60	23.4	5.7	-34.1	<40.0	43.8	38.8	54.0	15.2
4952.70	23.5	5.7	-34.1	<40.0	45.0	40.1	54.0	13.9
4996.80	23.7	5.7	-34.1	<40.0	45.1	40.4	54.0	13.6

(2) In the frequency range : 30 MHz to 1000 MHz

Measurement Distance : 3m : 10m

Measured Frequency ( MHz )	Antenna Factor ( dB/m )	Meter Reading		Maximum Field Strength ( dB $\mu$ V/m )	Limit ( dB $\mu$ V/m )	Margin for Limit ( dB )
		Horizontal Polarization ( dB $\mu$ V )	Vertical Polarization ( dB $\mu$ V )			
100.00	12.9	22.1	12.3	35.0	43.5	8.5
115.20	15.0	19.3	13.2	34.3	43.5	9.2
*300.03	23.3	18.0	20.2	43.5	46.0	2.5
422.37	21.5	8.0	9.3	30.8	46.0	15.2
556.81	24.1	10.5	3.4	34.6	46.0	11.4

[Note]

- (1) Antenna Factor includes the cable loss.
- (2) Above 1GHz, antenna factor includes both of the cable loss and pre-amplifier gain.
- (3) Above 5GHz, emission were no detectable.
- (4) \* mark in Measured Frequency : Measured with the tuned dipole antenna.  
no mark in Measured Frequency : Measured with the broadband antenna.

[Calculation method]

$$\text{Maximum Field Strength (dBuV/m)} \\ = \text{Meter Reading (at maximum level of Horizontal or Vertical) (dBuV)} + \text{Antenna Factor (dB/m)}$$

[Environment]

Temperature: 24°C

Humidity: 42%

[Tested Date/ Tester]

26 May 2004

Signature



Ikuya Minematsu

Test data in Graph

## Radiated Emission

KEC 第1暗室

KEC No. : A-008-04-C  
 Model No. : PBS-CS100  
 Serial No. : UTS00001  
 Test Condition : Rx mode

Reference Rule : FCC Part15  
 Rated Power : AC120V, 60Hz  
 Inspector : Ikuya Minematsu

LIMIT : FCC Part15 Subpart.B Class B (3m)  
 MARGIN : 5 dB

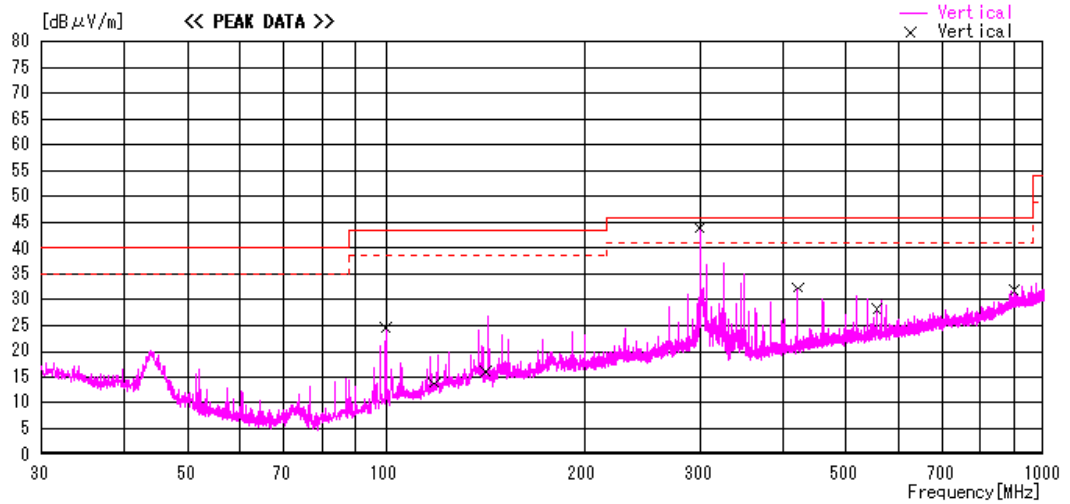
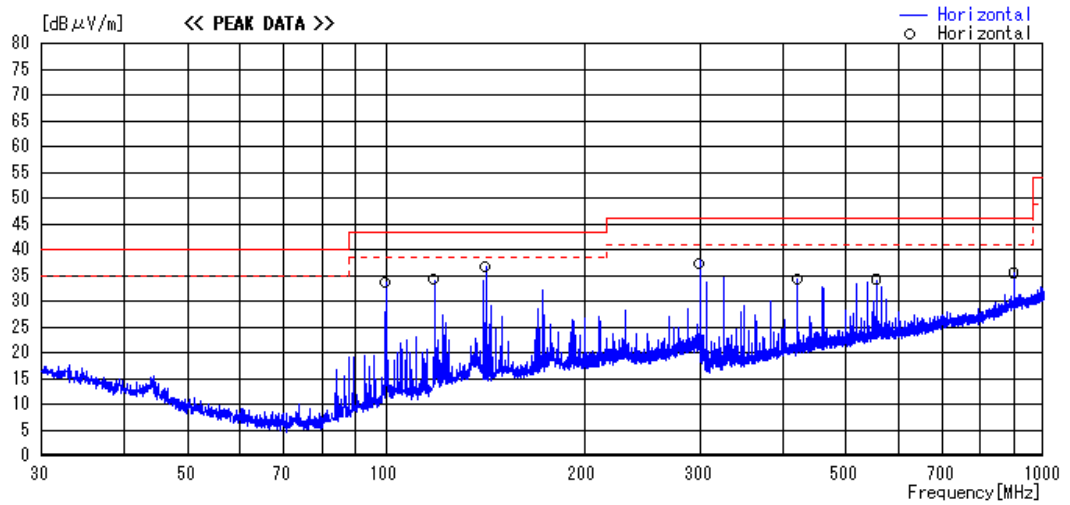

## 12. AC POWER LINE CONDUCTED EMISSION MEASUREMENT (§ 15.247 c2)

### 12.1. Test Procedure

<p>(1) Configure the EUT System in accordance with ANSI C63.4-2001 section 7.  <input checked="" type="checkbox"/>: without deviation, <input type="checkbox"/>: with deviation (details are found below)          See also the block diagram and the photographs of EUT System configuration in this report.</p> <p>(2) Connect the EUT's AC power cord to one Line Impedance Stabilization Network (LISN).</p> <p>(3) Any other power cord of other equipment is connected to a LISN different from the LISN used for the EUT.</p> <p>(4) Warm up the EUT System.</p> <p>(5) Activate the EUT System and run the software prepared for the test, if necessary.</p> <p>(6) Connect the spectrum analyzer (*1) to the measuring port of the LISN for the EUT, using a calibrated coaxial cable.</p> <p>(7) To find out an EUT System condition, which produces the maximum emission, the configuration of EUT System, the position of the cables, and the operation mode, are changed under normal usage of the EUT.</p> <p>(8) The spectrums are scanned from 150 kHz to 30 MHz and collect the six highest emissions minimum on the spectrum analyzer relative to the limits in the whole range.</p> <p>(9) The test receiver (*2) is connected to the LISN for the EUT, and the six highest emissions minimum recorded above are measured.</p>	<p>[Note]</p> <p>(*1) Spectrum Analyzer Set Up Conditions          Frequency range : 150 kHz - 30 MHz          Resolution bandwidth : 10 kHz          Video bandwidth : 1 MHz          Detector function : Peak mode</p> <p>(*2) Test Receiver Set Up Conditions          Detector function : Quasi-Peak/ Average (if necessary)          IF bandwidth : 10 kHz</p>
---	---

## 12.2. Test Results

Maximum Operation modes

Measurement with the Quasi-peak (Q-Peak) Detector

Measured Frequency ( MHz )	LISN Factor ( dB )	Meter Reading		Maximum RF Voltage ( dB $\mu$ V )	Limits		Margin for Limit ( dB )
		Va ( dB $\mu$ V )	Vb ( dB $\mu$ V )		Q-Peak ( dB $\mu$ V )	Average ( dB $\mu$ V )	
0.294	10.1	30.2	28.9	40.3	60.4	50.4	20.1
0.881	10.1	11.7	15.5	25.6	56.0	46.0	30.4
11.439	10.7	15.9	18.6	29.3	60.0	50.0	30.7
11.724	10.7	17.6	18.0	28.7	60.0	50.0	31.3
12.148	10.8	19.7	16.7	30.5	60.0	50.0	29.5
12.575	10.8	20.3	13.0	31.1	60.0	50.0	28.9
12.719	10.8	20.1	11.3	30.9	60.0	50.0	29.1
13.287	10.8	3.8	18.7	29.5	60.0	50.0	30.5

[Calculation method]

Maximum RF Voltage (dBuV)

= Meter Reading ( at maximum level of Va or Vb ) + LISN Factor (dB)

[Note]

(1) LISN Correction Factor includes the cable loss.

(2) If the measurement value with the quasi-peak detector meets the average limits, the measurement with the average detector is omitted.

[EUT Condition]

EUT operation : Op mode 1~6

[Environment]

Temperature: 24°C

Humidity: 42%

[Tested Date/ Tester]

28 May 2004

Signature



Ikuya Minematsu



## 13. USED TEST EQUIPMENTS AND CALIBRATION STATUS

Equipment	Manufacturer	Model No.	Specifications	KEC Control No.	Test Item (*)	Last Cal.	Next Cal.
Spectrum Analyzer	Agilent Technologies	8564E	Frequency Range 100Hz – 40GHz	SA-45	1,2,3,4,8	2004/5	2005/5
	Rhode & Schwarz	FSA	Frequency Range 100Hz – 1.8GHz	SA-35	8	2004/4	2005/4
	Agilent Technologies	E4403	Frequency Range 9kHz – 3.0GHz	SA-48	5,6,7,9	2003/6	2004/6
Test Receiver	Rhode & Schwarz	ESHS10	Frequency Range 9kHz – 30 MHz	FS-67	9	2004/2	2005/2
		ESVS10	Frequency Range 20 MHz – 1 GHz	FS-66	4,8	2004/2	2005/2
Pre-Amplifier	Hewlett Packard	8449B	Frequency Range 1GHz-26.5GHz Typ. Gain 30 dB	AM-52	2,4,8	2004/2	2005/2
		8447D	Frequency Range 0.1MHz-1.3GHz Typ. Gain 26 dB	AM-44	2,8	2003/6	2004/6
Biconical Antenna	Schwarzbeck	VHA9103	Frequency Range 30MHz-300MHz	AN-219	4,8	2004/2	2005/2
Log Periodic Antenna	Schwarzbeck	UHAL9108A	Frequency Range 300MHz-1 GHz	AN-216	4,8	2004/2	2005/2
LISN	Kyoritsu	KNW407	Frequency Range 150kHz-30MHz	FL-105	9	2004/5	2005/5
		KNW242	Frequency Range 10kHz-30MHz	FL-108	N/A	2004/5	2005/5
Tuned Dipole Antenna	Kyoritsu	KBA-511AS	Frequency Range 25MHz-500MHz	AN-132	N/A	2003/3	2005/3
		KBA-611S	Frequency Range 500MHz-1GHz	AN-115	N/A	2003/3	2005/3
Standard Gain Horn Antenna	Raven	91888-2	Frequency Range 1GHz – 2GHz	AN-116	3,4	2003/9	2005/9
				AN-211	3,4,8	2003/9	2005/9
		91889-2	Frequency Range 2GHz – 5GHz	AN-117	3,4	2003/9	2005/9
				AN-212	3,4,8	2003/9	2005/9
	Scientific Atlanta	12-3.9	Frequency Range 3.95-5.85GHz	AN-142	3,4	2003/9	2005/9
				AN-103	3,4,8	2003/9	2005/9
		12-5.8	Frequency Range 5.85-8.2GHz	AN-143	3,4	2003/9	2005/9
				AN-62	3,4,8	2003/9	2005/9
		12-8.2	Frequency Range 8.2-12.4GHz	AN-63	3,4	2003/9	2005/9
				AN-210	3,4,8	2003/9	2005/9
12-12.0	Frequency Range 12.4-18GHz	AN-64	3,4	2003/9	2005/9		
		AN-145	3,4	2003/9	2005/9		
12-18.0	Frequency Range 18GHz – 26.5GHz	AN-107	3,4	2002/8	2004/8		
		AN-211	3,4	2002/8	2004/8		

- Continued -

Equipment	Manufacturer	Model No.	Specifications	KEC Control No.	Test Item (*)	Last Cal.	Next Cal.
Power Meter	Rhode & Schwarz	NRVD	Frequency Range DC – 18GHz	VV-38	3,4	2004/3	2005/3
Thermal Power Sensor	Rhode & Schwarz	NRV-Z51	Frequency Range 10MHz – 18GHz 1uW to 100mW	VV-38-1	3,4	2004/3	2005/3
Precision Attenuator	Hewlett Packard	HP33340C010	Frequency Range DC – 26.5GHz typ. 10dB	AT-40-3	1,2,3,4,5, 6,7,8	2004/1	2005/1
Power Attenuator	WEIN SCHELL	46-20-43	Frequency Range DC – 18GHz typ. 20dB	AT-29-1	9	2004/1	2005/1
Band Eliminate Filter	MICRO-TRONICS	BRM12294	Fc=1800MHz Typ. 70dB reduce	FL-180	4,8	2004/3	2005/3
Low Temperature Chamber	TABAI	MC-710	Temperature -75°C - 100°C	CH-31	7	N/A	N/A
Directional Coupler	Hewlett Packard	86205A	Frequency Range 300kHz – 6GHz Coup.13dB(typ.)	AX-62	3,4	2003/8	2004/8
		11691D	Frequency Range 20GHz – 20GHz Coup.22dB(typ.)	AX-502	3,4	2003/11	2004/11
Digital Mobile Radio Transmitter Tester	Anritsu	MS8004A	—	—	7	N/A	N/A
Micro wave Power Amplifier	PENDEL	PT-3202	Frequency Range 1 – 2.5GHz 100W	AM-63	3	2003/9	2004/9
Coaxial Cable	SUHNER	SUCOFLEX	Length : 10m (SMA type)	CL-46	3,4,9	2004/2	2005/2
			Length : 2m (SMA type)	CL-42	3,4,9	2004/2	2005/2
			Length : 20m (N type)	CL-502	3,4	2003/6	2004/6
			Length : 1.5m (3.5mm type)	CL-620	N/A	2004/1	2005/1
			Length : 2.5m (3.5mm type)	CL-615	3,4,9	2004/1	2005/1
			Length : 0.3m (3.5mm type)	CL-619	1,2,5,6,7	2004/3	2005/3

- Continued -

[Note]

Test Item (*):	1	: RF Conducted Power Measurement
	2	: Antenna Conducted Spurious Emission Measurement
	3	: Transmit Power (EIRP) Measurement
	4	: Radiated Spurious (EIRP) Measurement
	5	: Occupied Bandwidth Measurement
	6	: Band Edge Measurement
	7	: Frequency Stability Measurement
	8	: Radiated Emission Measurement
	9	: AC Power Line Conducted Emission Measurement
	N/A	: Not Applicable.

The overall program of calibration and verification of equipment is designed and operated so as to ensure that measurements made by KEC are traceable to national standards of measurement or equivalent abroad.