

Designated by Ministry of International Trade and Industry

**KANSAI ELECTRONIC INDUSTRY DEVELOPMENT CENTER**

HEAD OFFICE  
6-8-7 NISHITENMA  
KITA-KU OSAKA 530-0047 JAPAN



Corporate Juridical Person

IKOMA TESTING LABORATORY  
12128 TAKAYAMA-CHO  
IKOMA-CITY NARA 630-0101 JAPAN

**TEST REPORT**Report No.A-010-00-C

Date: 31 March 2000

This test report is to certify that the tested device properly complies with the requirements of:

FCC Rules and Regulations Part 18 Subpart C.

The tests necessary to show compliance to the requirements were performed and these results met The specifications of requirement. The results of this report should not be construed to imply compliance of equipment other than that, which was tested. Unless the laboratory permission, this report should not be copied in part.

**1. Applicant**

Company Name : SANYO Electric Co., Ltd.  
Laundry & Cooking Appliances Division

Mailing Address : 1-1, Seta 1-chome, Otsu City, Shiga, 520-2198 Japan

**2. Identification of Tested Device**

Type of Device : INDUSTRIAL, SCIENTIFIC, AND MEDICAL EQUIPMENT  
Kind of Equipment Authorization : : DoC : Certification : Verification  
FCC ID : AEZM219  
Device Name : Microwave Oven  
Trade Name : SANYO  
Model Number : EM-V3400SW  
Serial Number : No.1 : Prototype : Pre-production : Production  
Date of Manufacture : March, 2000

**3. Test Items and Procedure**

: AC Power Line Conducted Emission Measurement  
: Radiated Emission Measurement (30MHz-1000MHz)

Above all tests were performed under: FCC/OET MP-5(1985)

: without deviation, : with deviation(details are found inside of this report)

**4. Date of Test**

Receipt of Test Sample : 7 March 2000  
Test Completed on : 28 March 2000

Eizo Hariya  
General Manager of Ikoma Testing Laboratory

**Table of Contents**

**1. GENERAL INFORMATION-----3**  
1.1 Product Description-----3  
1.2 Description for Equipment Authorization-----3  
1.3 Test Facility-----4

**2. TESTED SYSTEM-----5**  
2.1 Test Mode-----5  
2.2 Operaton of EUT System-----5  
2.3 Block Diagram of EUT System-----6

**3. MEASUREMENT OF ELECTRIC FIELD STRENGTH (30 MHz TO 1000 MHz) -----7**  
3.1 Reference Rule and Specification -----7  
3.2 Test Procedure-----7  
3.3 Test Arrangement -----8  
3.4 Photographs of EUT System Configuration -----9  
3.5 Test Results-----10

**4. LIST OF TEST INSTRUMENTS----- 11**

1. GENERAL INFORMATION

1.1 Product Description

The SANYO Model No. EM-V3400SW(referred to as the EUT in this engineering test report) is a Household Microwave Oven.

(1) Special Feature

Magnetron Frequency : 2450 MHz ± 50 MHz

RF Power : 1100 W

(2) Rated Power Supply

AC 120 V, 60 Hz

Protection Class 1(with ground connector)

(3) Contained Oscillator

4.0 ± 0.4 MHz(Main PCB)

1.2 Description for Equipment Authorization

(1) Category	:	<input type="checkbox"/> Class A	<input type="checkbox"/> Class B	<input checked="" type="checkbox"/> Not Applicable
(2) Reference Rule and Specification	:	FCC Rule Part 18 <input type="checkbox"/> Section 18.305 (a), (b)		
(3) Type of device	:	<input type="checkbox"/> Personal Computer & Peripherals <input type="checkbox"/> Other Digital Device <input checked="" type="checkbox"/> ISM Device		
(4) Kind of Equipment Authorization	:	<input type="checkbox"/> DoC	<input checked="" type="checkbox"/> Certification	<input type="checkbox"/> Verification
(5) Procedure of Application	:	<input checked="" type="checkbox"/> Original Equipment	<input type="checkbox"/> Modification	
(6) Highest Frequency used in the Device	:	2.45 GHz		
(7) Upper Frequency of Radiated Emission Measurement Range	:	<input type="checkbox"/> 1000 MHz	<input checked="" type="checkbox"/> 2000 MHz	<input type="checkbox"/> 5000 MHz
		<input checked="" type="checkbox"/> The Tenth Harmonic		

1.3 Test Facility

All tests described in this report were performed by:

Name: KANSAI ELECTRONIC INDUSTRY DEVELOPMENT CENTER (KEC)  
IKOMA TESTING LABORATORY

Open Area Test Site  No.1  No.2  No.3  No.4  
EMC M.C. Anechoic Chamber  No.1  
Shielded Room  No.2  No.4  EMC M.C. Shielded Room

Address: 12128, Takayama-cho Ikoma-city, Nara, 630-0101 Japan

These test facilities have been filed with the FCC under the criteria of ANSI C63.4-1992. The Open Area Test Site No.4, EMC M.C. Anechoic Chamber No.1, Shielded Room No.4 and EMC M.C. Shielded Room have been accredited by the NVLAP (Lab. Code: 200207-0) based on ISO/IEC Guide 25.

Also the laboratory has been authorized by ITI (Interference Technology International, (UK), TUV Product Service (GER) and TUV Rheinland (GER) based on their criteria for testing laboratory (EN45001).

## 1. TESTED SYSTEM

### 1.1 Test Mode

The compliance tests were performed under following operation mode.

#### Maximum Output Power Operation

### 1.2 Operaton of EUT System

- (1) Open the door of EUT.
- (2) Set the load as follows in EUT.
  - Receptacle
  - 1000 cc volume Beaker
  - Load for the test
  - 700 cc water with beaker
- (3) Close the door of EUT.
- (4) Set the output power to maximum.
- (5) Set the cooking time.
- (6) Push the start pad.  
Then start the cooking.

### 2.3 Block Diagram of EUT System

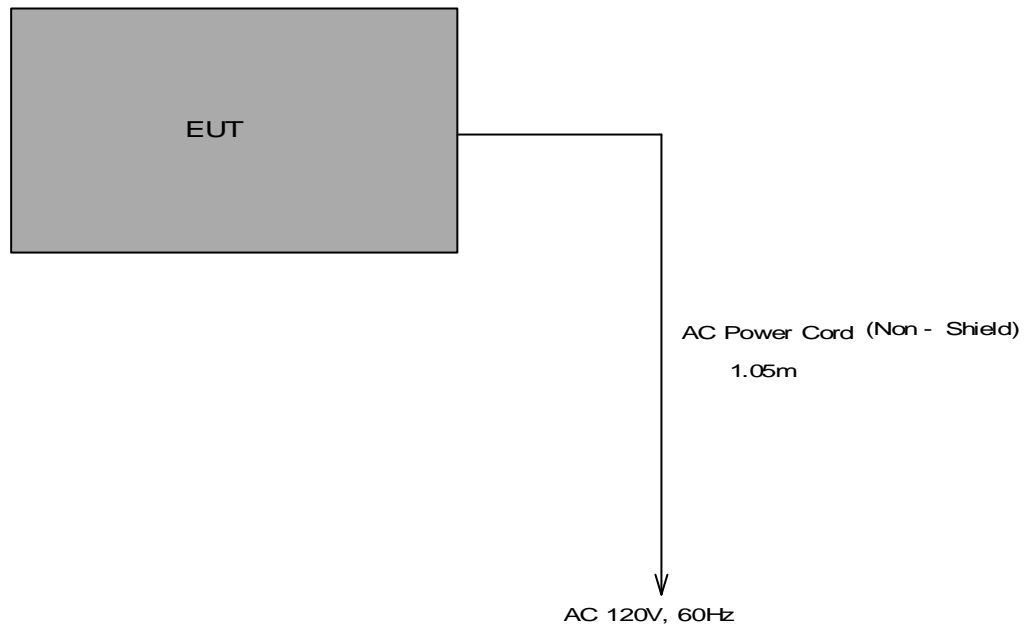

### 3. MEASUREMENT OF ELECTRIC FIELD STRENGTH (30 MHz TO 1000 MHz)

#### 3.1 Reference Rule and Specification

FCC Rule Part 18 Subpart C  
FCC/OET MP-5(1985)

#### 3.2 Test Procedure

(1) Configure the EUT.

[ See 3.3 Test Arrangement and 3.4 Photographs of EUT System Configuration]

[Note]

The power cords for the EUT are connected through the receptacle with the turn floor to the CVCF placed under the ground plane.

(2) Operate the EUT.

(3) To determine the emissions of the EUT, preliminary radiated measurement was performed at a closer distance than that specified for final radiated measurement using the broad band antenna and the spectrum analyzer.

(4) To search the frequency of maximum emission level on the spectrum analyzer, change the EUT System configuration, move the signal cables and the power cords, change the EUT conditions.

(5) The spectrum was scanned from 30 MHz to 1000 MHz and collect the emissions on the spectrum analyzer.

(6) The collected emissions for final test were measured at the specified distance using the tuned dipole antenna or broad band antenna and the test receiver \*1).

[Note]

\*1) Test Receiver Operation Mode

Detector Function : Average

IF Band Width : 120 kHz(frequency range in 30 MHz - 1000 MHz)

### 3.3 Test Arrangement

[Open Site]

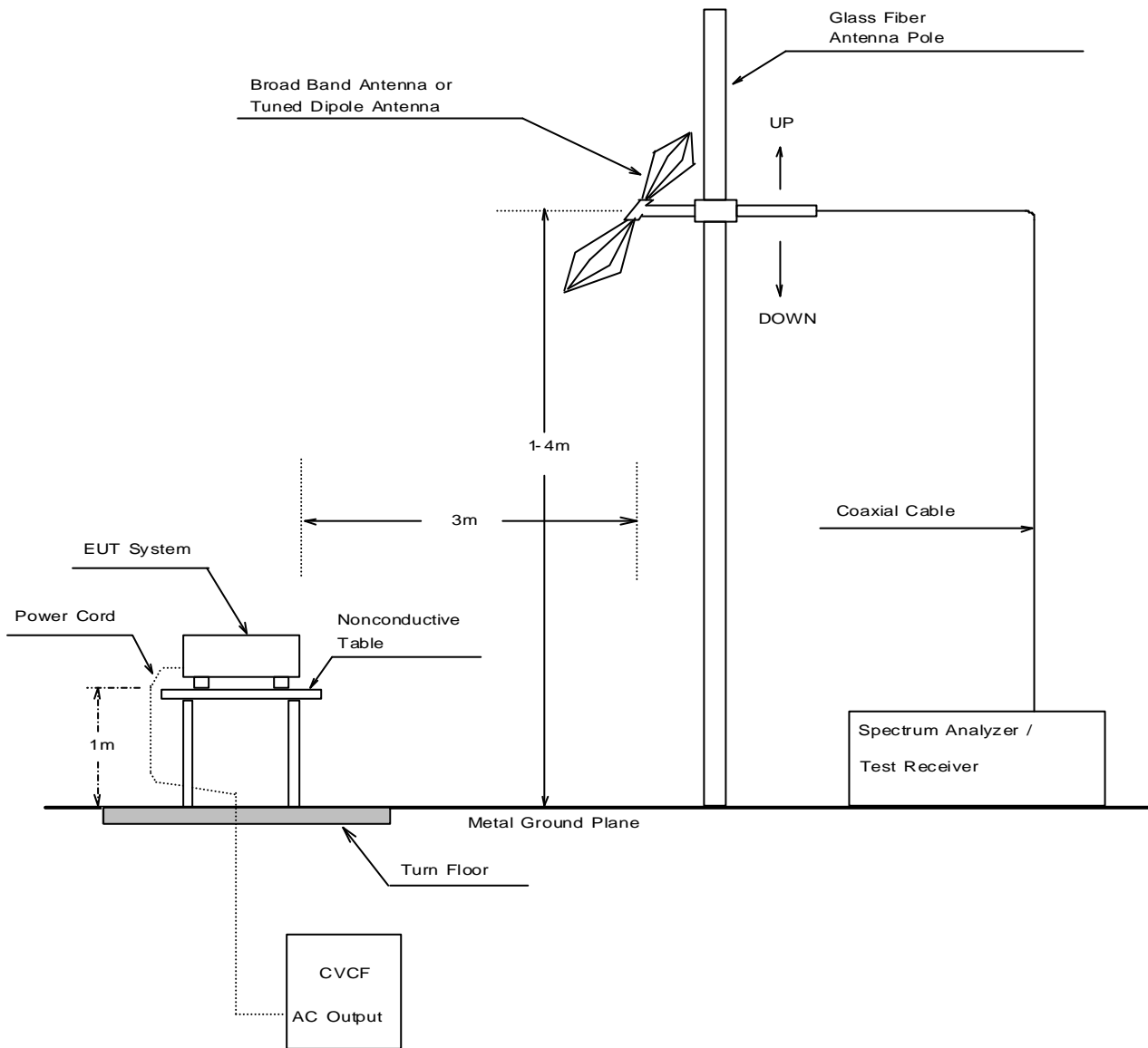



### 3.4 Photographs of EUT System Configuration

front view



rear view



3.5 Test Results

Measurement Distance : 3m : 10m

Measured Frequency (MHz)	Antenna Factor (dB/m)	Meter Reading		Conversion Factor (dB)	Maximum Field Strength (dBuV/m)	Limits at 300 m (dBuV/m)	Margin for Limits (dB)
		Horizontal (dBuV)	Vertical (dBuV)				
44.90	13.2	-6.5	-2.0	-40.0	-28.8	31.4	60.2
67.50	8.5	-5.0	-6.5	-40.0	-36.5	31.4	67.9
84.20	8.8	-3.0	-3.0	-40.0	-34.2	31.4	65.6
103.90	12.6	-2.5	-1.0	-40.0	-28.4	31.4	59.8
374.00	19.4	-10.0	-10.0	-40.0	-30.6	31.4	62.0
692.00	25.8	-9.0	-10.0	-40.0	-23.2	31.4	54.6
732.00	26.5	-5.0	-7.5	-40.0	-18.5	31.4	49.9

[Note]

(1) Antenna Factor includes the cable loss.

(2) \* mark in Measured Frequency : Measured with the tuned dipole antenna.  
 No mark in Measured Frequency : Measured with the broadband antenna.

(3) Conversion Factor : distance correction factor from 3 m to 300 m.

---

[Calculation method]

Maximum Field Strength (dBuV/m)  
 = Meter Reading (at maximum level of Horizontal or Vertical) (dBuV) + Antenna Factor (dB/m)  
 +Conversion Factor(dB)

[ Environment ]

Temperature : 20 °C Humidity : 55 %

Tested Date : 28 March 2000      Tester Signature \_\_\_\_\_  
 Yasunari Kawai

## 4. LIST OF TEST INSTRUMENTS

Instrument	Manufacturer	Model No	Specifications	KEC Control No.	if used, checked by "X".	Last Cal.	Next Cal.
Test Receiver	Rohde & Schwarz	ESVP	Frequency Range 20 MHz - 1000 MHz	FS-48-3	<input type="checkbox"/>	1999/5	2000/5
		ESV	Frequency Range 20 MHz - 1000 MHz	FS-55	<input checked="" type="checkbox"/>	1999/4	2000/4
Spectrum Analyzer	Advantest	TR4172	Frequency Range 50 Hz - 1.8 GHz	FS-44-2	<input checked="" type="checkbox"/>	1999/9	2000/9
Pre-Selector	Advantest	TR14037	Frequency Range 10 kHz - 1.0 GHz	FS-44-3	<input checked="" type="checkbox"/>	1999/9	2000/9
Biconical Antenna	Schwarzbeck	BBA9106	Frequency Range 30 MHz – 300 MHz	AN-80	<input checked="" type="checkbox"/>	2000/2	2001/2
Log-Periodic Antenna	Schwarzbeck	UHALP 9107	Frequency Range 300 MHz – 1 GHz	AN-97	<input checked="" type="checkbox"/>	2000/2	2001/2
Tuned Dipole Antenna	Kyoritsu	KBA-511S	Frequency Range 25 MHz – 500 MHz	AN-135	<input type="checkbox"/>	2000/3	2001/3
		KBA-611S	Frequency Range 500 MHz - 1 GHz	AN-137	<input type="checkbox"/>	2000/3	2001/3