

# INSTALLATION MANUAL

MODEL: WEATHER RADAR

TYPE: **WR110**






**FURUNO**

[www.furuno.com](http://www.furuno.com)

# SAFETY INSTRUCTIONS

The user and installer must read the appropriate safety instructions before attempting to install or operate the equipment.

 <b>DANGER</b>	Indicates a hazardous situation which, if not avoided, will result in death or serious injury.
 <b>WARNING</b>	Indicates a potentially hazardous situation which, if not avoided, could result in death or serious injury.
 <b>CAUTION</b>	Indicates a potentially hazardous situation which, if not avoided, can result in minor or moderate injury.

## WARNING



### Radio Frequency Radiation Hazard

The radar antenna sends the electromagnetic radio frequency (RF) energy. This energy can be dangerous to you, especially on your eyes. Do not look at the radiator or near the antenna when the antenna is rotating.

The distances at which RF radiation levels of 100 W/m<sup>2</sup>, 50 W/m<sup>2</sup>, and 10 W/m<sup>2</sup> exist are shown in the table.

DO NOT go near more than 12.7m (Safety standard is 10 W/m<sup>2</sup>).

NOTE: The value is applied for being installed in the public space. And it is defined on human body surface over any 6-minutes period with the flux density averaged from the measurement.

Distance from Antenna	-m	-m	12.7m
Power flux density	100 W/m <sup>2</sup>	50 W/m <sup>2</sup>	10 W/m <sup>2</sup>

## WARNING



### Do not open the radome.

Electrical shock can occur. Only qualified personnel should work inside the equipment. Turn off the circuit breaker in the JCU if it has to open the radome.



### Wear a hard hat and safety belt when mounting the Antenna Unit.

Serious injury or death can result if someone falls from the radar antenna.



### Do not use any other power except 100 to 240 VAC.

Connection of an incorrect power supply can cause fire or damage the equipment.



### Turn off the power immediately if water leaks into the equipment or smoke or fire is coming from the equipment.

Failure to turn off the equipment can cause fire or electrical shock.







### Do not operate the equipment with wet hands.





Electrical shock can occur.



### Do not disassemble or modify the equipment.

Fire or electrical shock can occur.

	<b>Use only the specified power cable.</b> Fire or damage to the equipment can result if a different cable is used.
	<b>Use the power supply grounded certainly.</b> Electrical shock or defect of operation can occur.
	<b>When a thunderbolt is expected, do not approach a system or do not touch a hand.</b> There is a possibility of receiving an electric shock. A worker's safety is guaranteed although the measures which protect apparatus from indirect lightning stroke surge are taken against this machine. It is not a thing. Moreover, if a direct stroke is impressed, it may break down.
	<b>Attach securely protective earth to the unit.</b> The protective earth (grounding) is required to the AC power supply to prevent electrical shock.

 <b>CAUTION</b>	
	<b>Do not put liquid-filled containers on the top of the equipment.</b> Fire or electrical shock can occur if a liquid spills into the equipment.
	<b>Establish space in the surroundings of apparatus as much as possible.</b> It becomes a cause of performance degradation and failure.
	<b>Do not put any strong impact to LCD because of glass.</b> Serious injury may cause by broken glass.

## WARNING LABEL

Warning labels are attached to the equipment. Do not remove any label.  
If a label is missing or damaged, contact us for the replacement.



### Antenna Unit (radome)

Name: Radiation Warning Label  
Type : 03-142-3201-0  
number : 100-266-890-10

## POWER SUPPLY LABEL

100-240 VAC

SINGLE PHASE, 50/60 Hz

POWER CONSUMPTION: MAX Watt

RATED AMPERE



## WR110 restrictions

There are restrictions frequency band as follows to use at Lithuania and Slovakia.

WR110 is operated with a channel from the following four channels:

CH1: 9422.5MHz, CH2: 9427.5MHz, CH3: 9432.5MHz, CH4: 9437.5MHz

# WEATHER RADAR WR110 Installation manual

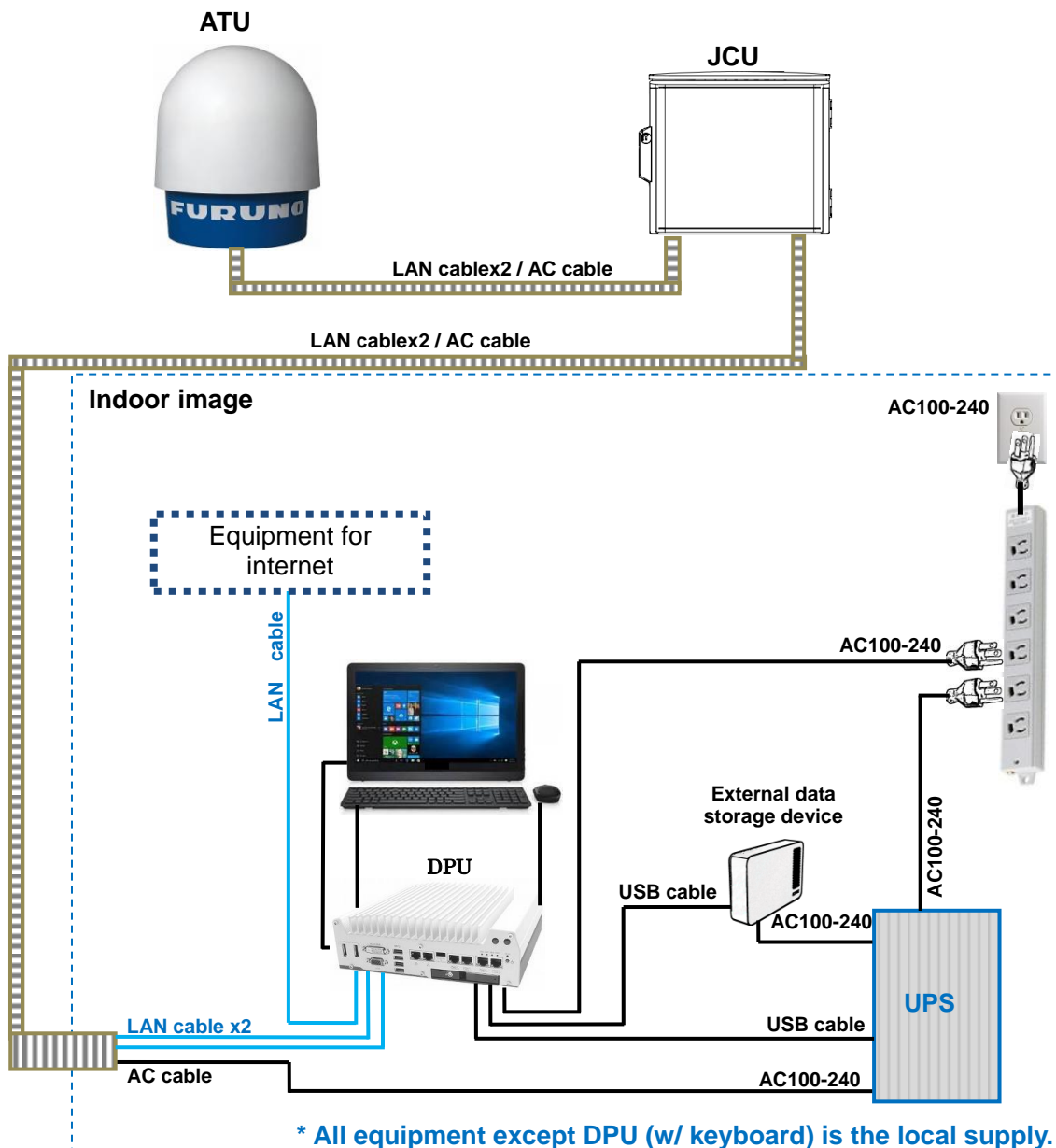
## Contents:

SAFETY INSTRUCTIONS .....	i	10. Specification	
System Configuration .....	iv	10.1. Antenna Unit .....	42
1. System Summary.....	1	10.2. Data Processing Unit .....	43
2. Equipment Configuration		11. UPS settings	
2.1. Standard Equipment of WR110 .....	3	11.1. APC product .....	44
2.2. Optional accessories for installation .....	4	11.1.1. Login.....	45
2.3. Construction materials list.....	4	11.1.2. Power Protection Strategy .....	45
2.4. Overall appearance .....	4	12. Windows Language settings .....	48
3. Prior confirmation		13. Create map file for RainMap	
3.1. Confirmation items .....	5	13.1. Required software .....	50
3.2. Power equipment .....	5	13.2. Web Browser .....	50
3.3. Measurements .....	5	13.3. Display .....	50
3.4. LAN equipment .....	5	13.4 Overview .....	50
3.5. Peripherals equipment .....	6	13.5 Create a map .....	51
4. Precautionary item.....	7	13.5.1. Cut maps .....	51
5. Construction		13.5.2. Change color of map.....	64
5.1. Antenna Unit .....	8	13.5.3. Confirm a created map.....	70
5.2. Junction Unit .....	14	13.5.4. Create a map license .....	73
5.3. Data Processing Unit.....	14	APPENDIX	
5.4. Open the radome temporary .....	15	1. Outline drawing .....	74
6. Operation Test		2. System diagram .....	76
6.1. Before cover .....	16		
6.2. After cover .....	17		
7. Install TeamViewer .....	18		
8. DPU operation			
8.1. File.....	20		
8.2. Disp .....	20		
8.3. Setting			
8.3.1. Setting .....	21		
8.3.2. Service.....	26		
8.3.3. Precipitation estimates methods			
.....	29		
8.3.4. Management list .....	30		
8.4. Radar Operation.....	32		
8.5. Help .....	33		
8.6. Stop radar operation .....	33		
8.7. RainPlay operation.....	34		
8.8. Initial setting of Azimuth .....	37		
8.9. Log file function .....	39		
9. Menu Tree.....	40		

# System Configuration

The observation system consists of an Antenna Unit (radome), a Signal Processing Unit (connection box), and a Data Processing Unit (indoor unit) are shown below.

- (1) Antenna Unit (radome)
- (2) The antenna, stored in the radome, turns to radiate the radio waves.  
The radiated waves are backscattered by precipitation particles on the propagation path, return to the antenna, and are processed by RF converter to transfer the signals to the Signal Processing Unit.
- (3) Signal Processing Unit (connection box)  
Signal Processing Unit is stored in the connection box, and processes received signals digitally.  
The digitally-processed signals are transferred to the Data Processing Unit via 100Base-T (LAN).
- (4) Data Processing Unit (indoor unit)  
Data Processing Unit is displaying and operating the weather radar.  
Consumer must prepare the external storage device for recording the weather observation data if necessary.



# 1. System Summary

This system observes the development of rain clouds, outputs the strength of precipitation and the speed of rain clouds (Doppler speed), and observes phenomena of rainfall.

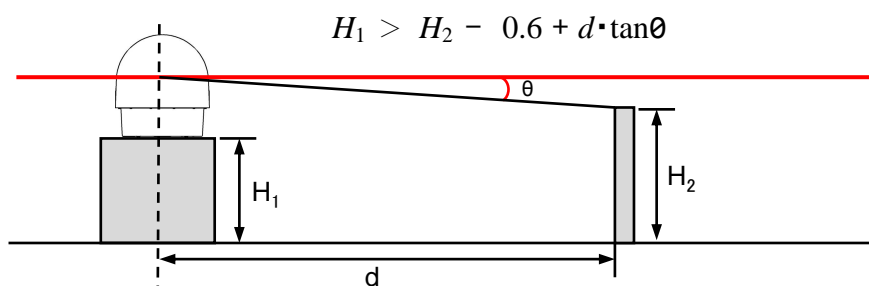
## Features:

1. While installing antenna on a rooftop of building in urban area, it must be installed in the safety area covered by lightning rod based on JIS A4201 and IEC61024-1.
2. Nothing should be surrounded around the antenna area.

## Safe distance:

- If H1 is taller than 2.2 meters, it is safe unless touch the antenna directory.
- If H1 is shorter than 2.2 meters, do not enter within a radius of 13meters from the antenna.

Notice: It based on the standard of 2 meters tall person.



## Safety zone around radar

e.g.: H2 (Height) = 2m,

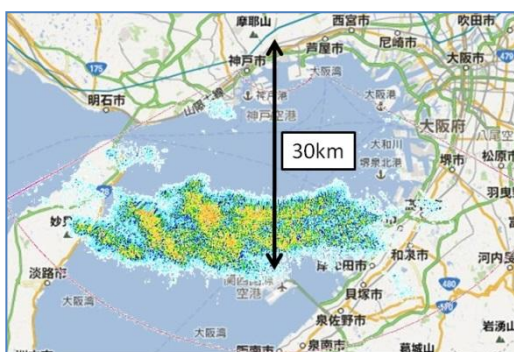
d (Distance between center of the antenna and human) = 13m,

$\theta = 3.5^\circ$  (Minimum elevation is  $-2^\circ +$  a half of beam width  $1.5^\circ$  )

$$H_2 - 0.6 + d \cdot \tan\theta = 2 - 0.6 + 13 \cdot \tan 3.5^\circ = 2.195\text{m} < H_1$$

Therefore, H1 (Height of base) = 2.2m,

3. High Resolution Rain Observation, Rain Cloud, Density and Speed Observation.
4. Solid-state Transmitter replaces an aging device such as a magnetron.





Sample image of WR-2100



Indonesia



Indonesia



Denmark



Belgium

## 2. Equipment configuration

MODEL	TYPE
WEATHER RADAR	WR110

### 2.1. Standard Equipment of WR110

Main Unit			
Items	Units	Descriptions	Qty
Antenna Unit	WR110 -ATU	Size : $\Phi$ 980mmxH1068mm (include radome) Weight : 65Kg Weight of radome only: Upper 15kg (incl. 12pcs of M10x35 stopper hexagon bolt), Bottom 11kg	1
Junction Unit	WR110 -JCU	Size: W330 x D130x H336mm (connection box) Weight: 2.0kg Incl. Fixing band ( $\phi$ 26-101, W20mm), M4x35mm screw	1
Data Processing Unit	WR110 -DPU	Unspecified. Keyboard is included. Note: Please prepare mouse and display separately because these are excluded.	1

### Cables & Tube

Antenna Unit (radome) --- Junction Unit

Items	Descriptions	Length	Qty
LAN cable	100Base-T (STP Cat5e or better), Length depends on measure value. Incl. LAN connector w/ cover	5m <sup>(*)</sup>	2
AC Power cable	Shielded VCTF 2sq 3core or equivalent Incl. crimped Terminal	5m <sup>(*)</sup>	1
Protective tube	PF tube conduit Inner diameter : 28 mm	10m <sup>(**)</sup>	1

### Accessories for installation (Fixed radome and stand)

Items	Descriptions	Qty
M16x200mm Hexagon Bolt	Material : SUS304	4
M16 Nut	Material : SUS304	12
M16 Split Lock Washers	Material : SUS304	4
M16 Flat Washers	Material : SUS304	8
M16 Large Flat Washers	Material : SUS304	4

### Accessories for maintenance

Items	Descriptions	Qty
M10 x500 Stud Bolt Steel	Holding the radome cover up above in order to access inside the radome when maintenance	6
M10 Nut	Fix the length of stud bold for lifting up the radome	6
M10 Slip on Lock Nut	Holding the radome cover up above in order to access inside the radome when maintenance	6

<sup>(\*)</sup> Basic length of cable is 5m, and there are 10m, 15m, 20m for option.

<sup>(\*\*)</sup> Cut into two pieces to adjust a length of protective tube between ATU and JCU.

Note: For the stand of radar depends on installation environment, therefore consultation will be necessary.



## 2.2. Optional accessories for installation (Set of lifting tool)

Items	Descriptions	Qty
Lifting tool for radome	Size: 1000mm x 1018mm x 40mm, Weight: 10kg	1
M12 Eye bolt set	For lifting up radome by crane (incl. nut, washer)	4
M12x40mm bolt set	Incl. split lock washer, flat washer, nut.	4
M16 Nut	Material : SUS304 (Fixed between radome and stand)	8
M16 Split Lock Washers	Material : SUS304 (Fixed between radome and stand)	4
M16 Flat Washers	Material : SUS304 (Fixed between radome and stand)	8

## 2.3. Construction material list (Local contractor/client supply)

<b>Cables &amp; Tube</b>			
Junction Unit --- Data Processing Unit			
Items	Descriptions	Length	Qty
LAN cable	100Base-T (STP Cat5e or better), Length depends on measure value. Incl. LAN connector w/ cover	by measure	2
AC power cable	Shielded VCTF 2sq 3core or equivalent. Incl. crimped Terminal	by measure	1
Protective tube	PF tube conduit Inner diameter : 28 mm	by measure	2
<b>Basic construction equipment</b>			
Items	Descriptions	Qty	
Heavy Duty Cable Tie (2 types)	Nylon 6/6 w/ weather resistance 140mm, 300mm	100	
<b>Basic construction tool</b>			
Items	Descriptions		
Hex key (Ball-head type)	M4 (3mm)		
Ratcheting Wrench	M5 (8mm), M12 (19mm), M16 (24mm), Adjustable wrenches (up to 30mm)		
Socket Wrench	M10 (17mm) for fixing radome top/bottom		
Exclusive Philips Screwdriver #1	Multiuse		
Philips Screwdriver #2	Multiuse		
Slotted Screwdriver 3mm	Multiuse		
Cable/Wire cutting scissors	Multiuse		
Flat nippers	Multiuse		
Wire Strippers	For electric wiring work		
Ratchet Wire Crimper 2sq	For electric wiring work		
LAN cable strippers	For LAN cable work		
LAN Ratchet Crimper	For LAN cable work		
LAN cable tester	For LAN cable work		

## 2.4. Overall appearance

Refer to the APPENDIX for Drawing of WR110

### 3. Prior confirmation

#### 3.1. Confirmation items

1. The mount plate must be installed properly for Antenna Unit (radome).
  2. Power cable (AC100V-240V) must be laid safely.
  3. Power cable thickness should be selected depends on its length.
  4. Frequency of AC power source must be 50Hz or 60Hz sin wave and single-phase current.
  5. All engineers must wear the safety appliances such as a helmet, and safety shoes during an installation of Antenna Unit. It is very dangerous that Antenna might hit a head by turning. DO NOT look the antenna closer while radar is in operation. This energy can extremely damage to the human body and especially to the eyes. Furthermore, DO NOT point the antenna to the people closer while transmitting.
- \* As shown in the beginning of warning (Table on page i, Radio Frequency Radiation Hazard), the distance of transmit radio wave to be  $100\text{W}/\text{m}^2$ ,  $50\text{W}/\text{m}^2$ ,  $10\text{W}/\text{m}^2$ . The value of safe standard is  $10\text{W}/\text{m}^2$ , do not go closer than 12.7m to the radar.

#### 3.2. Power equipment

This equipment must need 1KVA x1 line of power, with ground outlet (3 pin type)

#### 3.3. Measurements

Items	Descriptions			Remarks
Digital Multimeter	<u>Voltage</u> AC : 85 to 240 V DC : 1 to 50V	<u>Current</u> AC : 1 to 10 A DC : 1mA to 1A	<u>Resistor</u> 0.1 to 10M ohm	Tester Lead Cables
Angle Meter	Measurement range : $\geq 45\text{deg}$ Accuracy : within $\pm 0.2\text{deg}$			Levelling of radar

#### 3.4. LAN equipment

- 1) Use Cat5e (or better grade) of 100Base-Tx LAN cable for transferring the data from the Data Processing Unit to output equipment.
- 2) Be prepared High speed broadband (approx.100Mbps) for using remote maintenance.

\*Low speed broadband may cause slow access on remote to support a system.

### 3.5. Peripherals equipment

The purposes of using these peripherals are for remote control:

#### 1. Wired router

Function	Connect with an external network
WAN port	10/100/1000BASE-T, 1 port, MDI/MDI-X auto switch
LAN port	10/100/1000BASE-T, 4 port or more, MDI/MDI-X auto switch
Input voltage	AC100V-240V, Single phase, 50/60 Hz
Remarks	YAMAHA RTX810 or equivalent

#### 2. SW HUB

Function	Connect with LAN
LAN port	10/100/1000BASE-T, 5 port or more, MDI/MDI-X auto switch
Input voltage	AC100-240V, Single phase, 50/60 Hz
Remarks	ELECOM EHC-G05MN-HJ or equivalent

#### 3. Uninterruptive Power Supply

Function	Automatically shut down after 10 minutes operation during a power failure
Output voltage	More than 1,000VA
Input voltage	AC100-240V, Single phase, 50/60 Hz
Remarks	APC Smart-UPS series w/ network or equivalent

#### 4. External data storage device

Function	Save scan data
Capacity	3TB or more
Interface	USB3.0 (Note: Plug in USB3.0 cable in to the USB3.0 port of DPU)
Input voltage	AC100-240V, Single phase, 50/60 Hz
Remarks	WD 3TB or equivalent

#### 5. Remote Power Controller

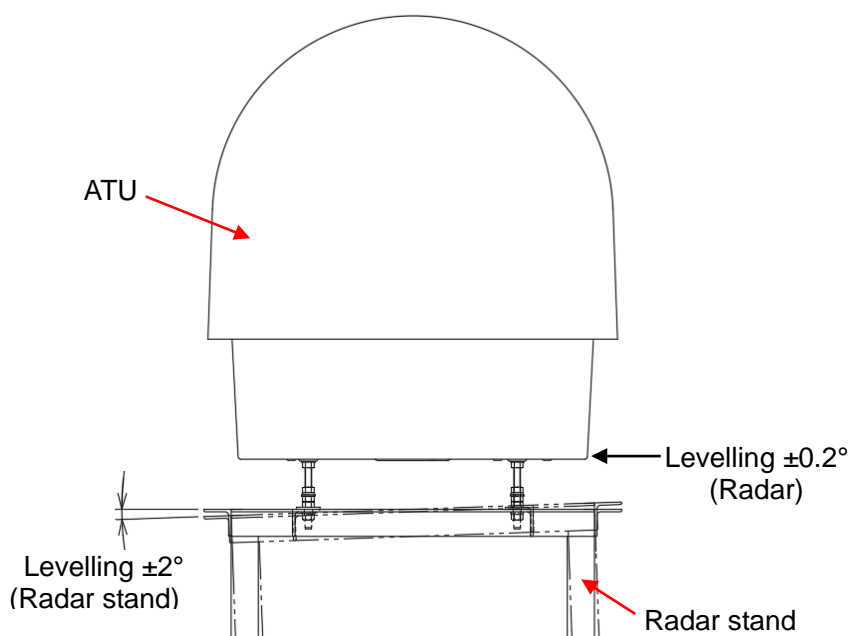
Function	Reboot the power of equipments by remote
Capacity	2-4 individual outlet power control (ON/OFF/Reboot/Schedule)
Interface	10BASE-T/100BASE-TX RJ-45X1, RS232
Input voltage	AC100-240V, Single phase, 50/60 Hz
Remarks	AVIOSYS IP POWER series or equivalent

## 4. Precautionary item

- 1) Use only the commercial power supply of single phase 100-240VAC.
- 2) DO NOT overhaul or remodel.
- 3) DO NOT work during the thunder is occurring.
- 4) DO NOT scratch, cut, forcedly bend, pull, twist, bundle, or damage the power cable. Also, not to put a heavy thing on top or interpose.
- 5) DO NOT touch inside equipment with a wet hand.
- 6) Connect the ground conductor for protecting equipment and electric shock prevention from lightning induction and ground leakage.
- 7) Cleaning instruction: Use dried soft cloth to wipe the surface. If it is difficult to remove stains, use the cloth soak with a neutral detergent to clean it. Please DO NOT use an alcohol or an organic solvent (e.g.: thinner) to clean it.

### For optional equipment:

Please refer to attached documents of UPS, Router, and other equipment separately.



Angle of the radar stand should be levelling within  $\pm 2$  degrees.

## 5. Construction

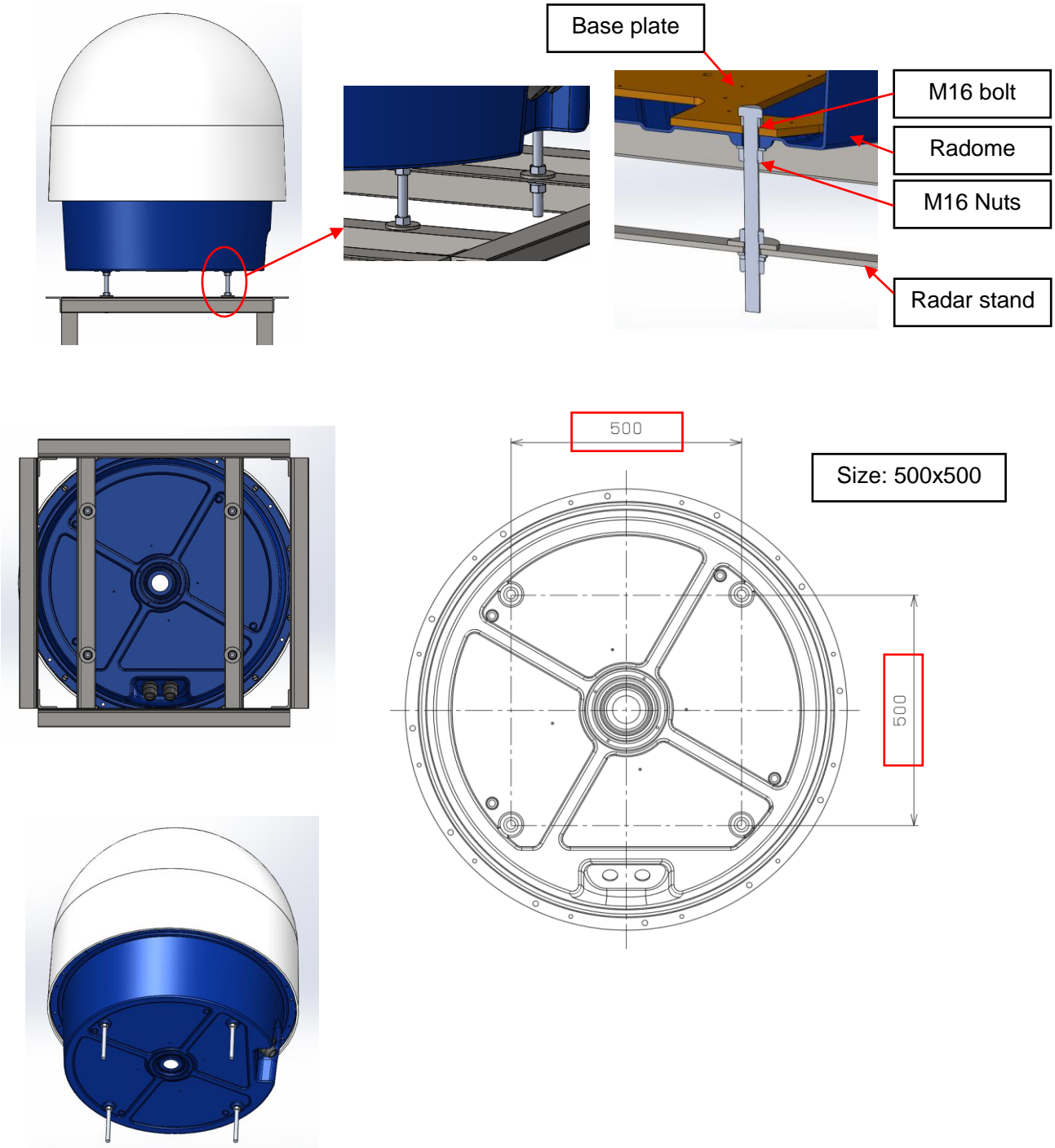
All installation places will be considered for installing DPU, cables, pipes, and mount plate during the environmental survey.

### 5.1. Antenna Unit

<Case 1>

A way of using a frame stands to mount the Antenna Unit.

Use 4 pieces of M16x200 Bolts to adjust a level while join and fix the lifting tool and a frame stand.





1. Levelling the Antenna Unit

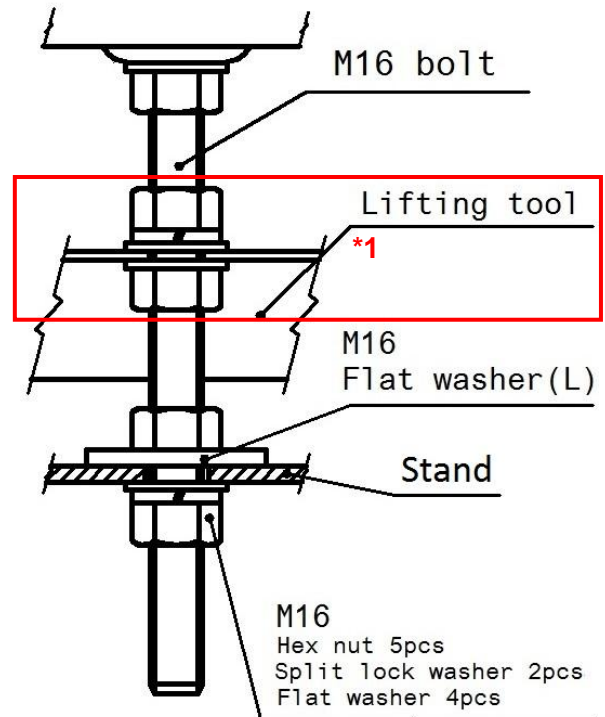
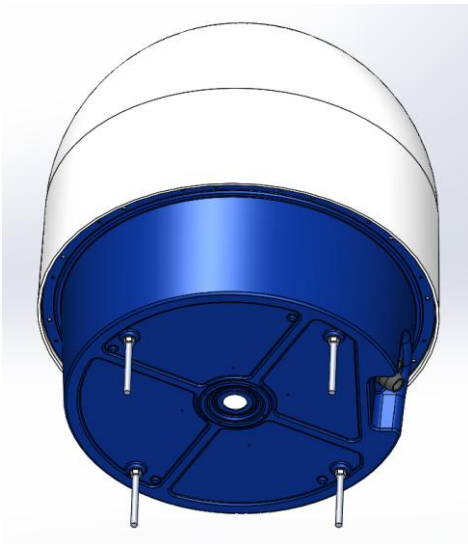
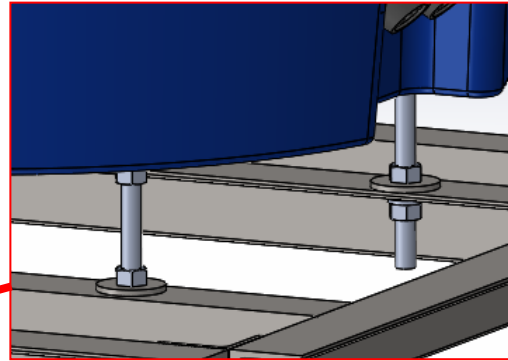
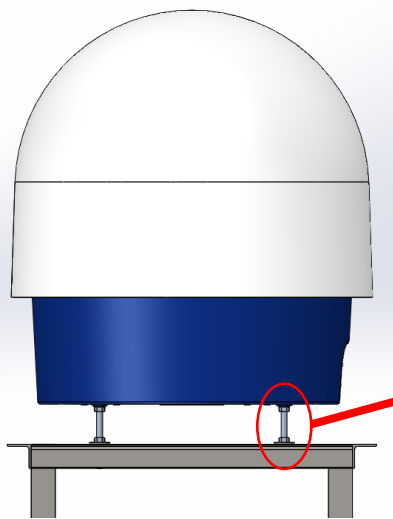


Fig. 5-2. M16 bolt

\*1: These hex nuts, flat washers, split lock washers are attached with the lifting tool (optional).

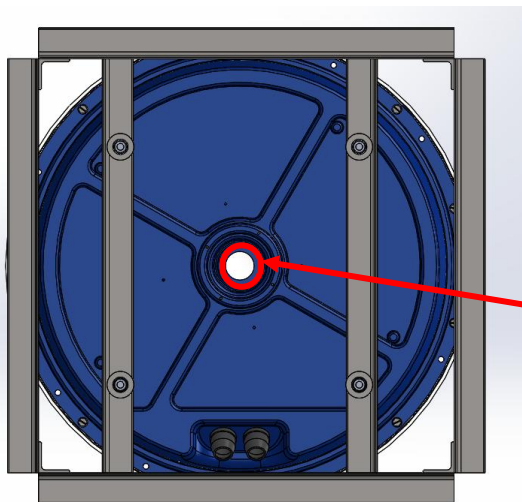
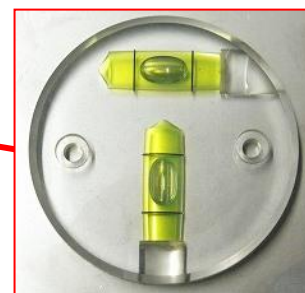
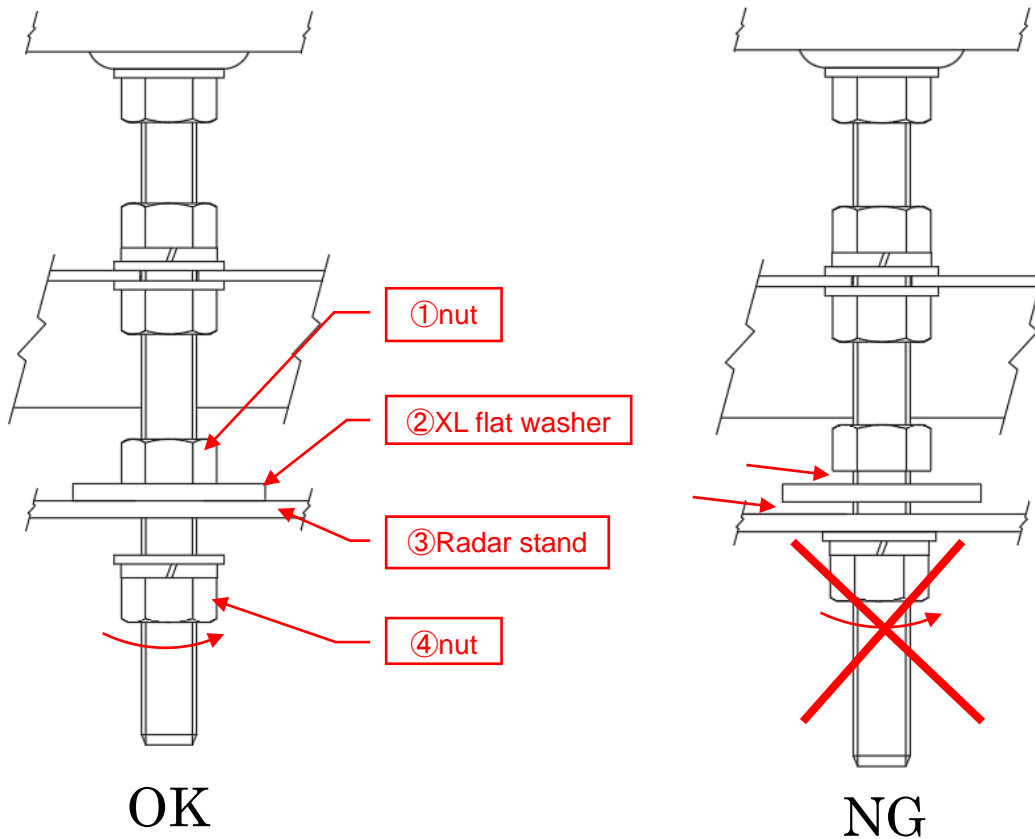
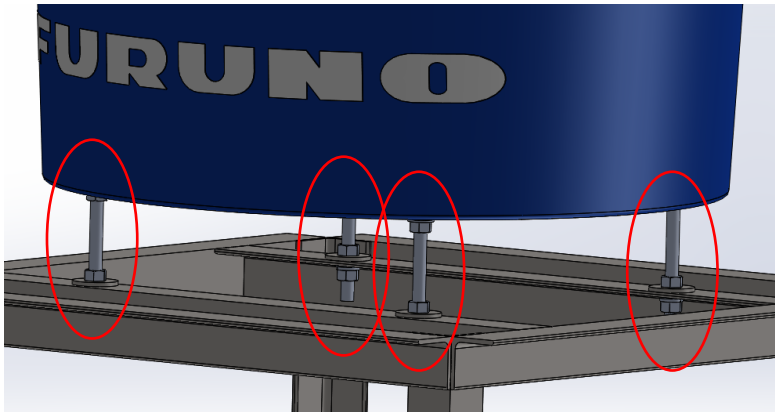


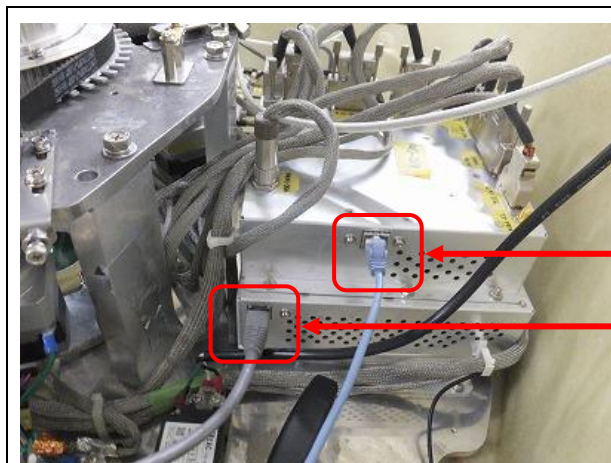
Fig. 5-1. Under the radar



Check with the bubble level under the radar to turn M16 hex nut (Fig.5-2) for adjusting the level of radar.

After leveling the radar, make sure to confirm every four nut touches to the top of the stand before pinching the stand from the bottom, i.e. between ①nut, ②XL flat washer, and ③radar stand are not having gap before tighten the ④nut, in order not to strain the radome and stand.

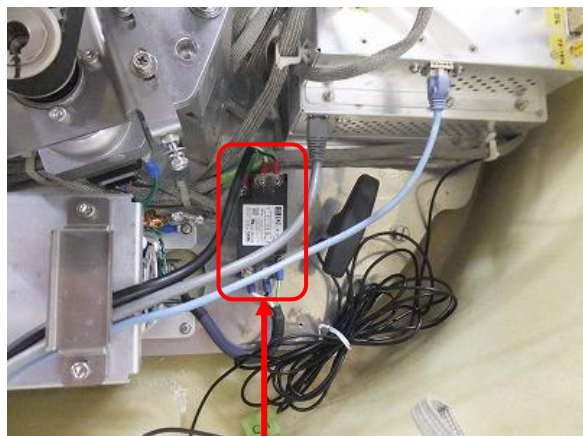




## 2. Connect LAN cable for MONI-CON and SPU

MONI-CON LAN connector

SPU LAN connector



## 3. Wire the power filter

Caution: Make sure an electric current is not flow

- (1) Fix / Connect AC power cable (3pin)
- (2) Confirm the circuit diagram of power filter label before connecting.
- (3) Connect the LINE side to match with the line color of LOAD side and LINE side.

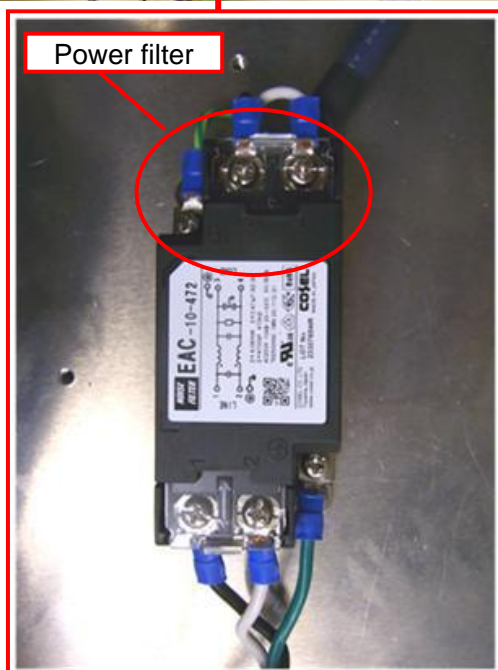
<Wire color>

P/L	+	Black
N	-	White
GND	FG	Green

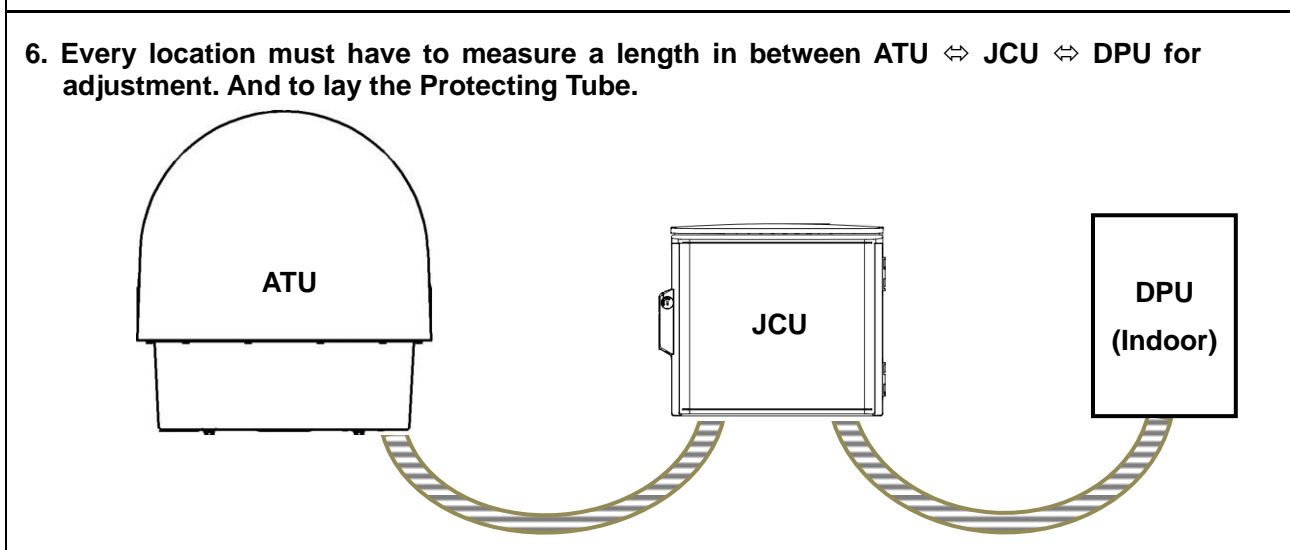
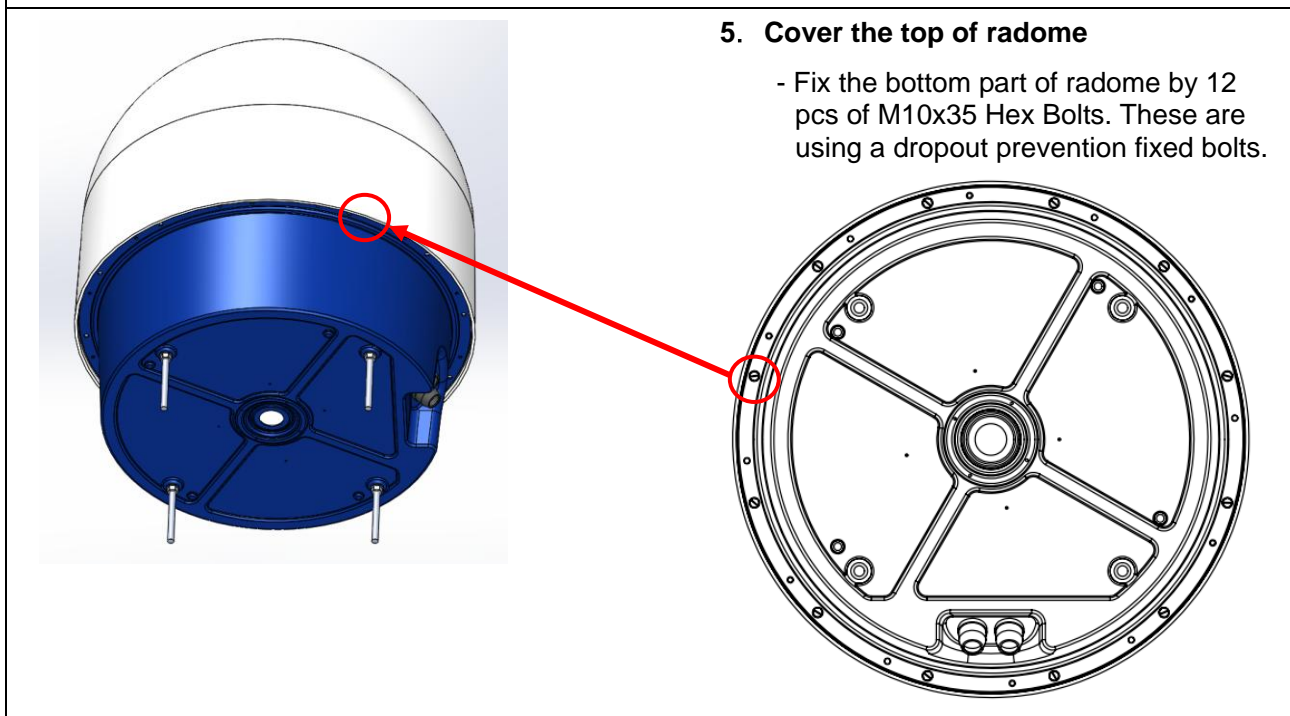
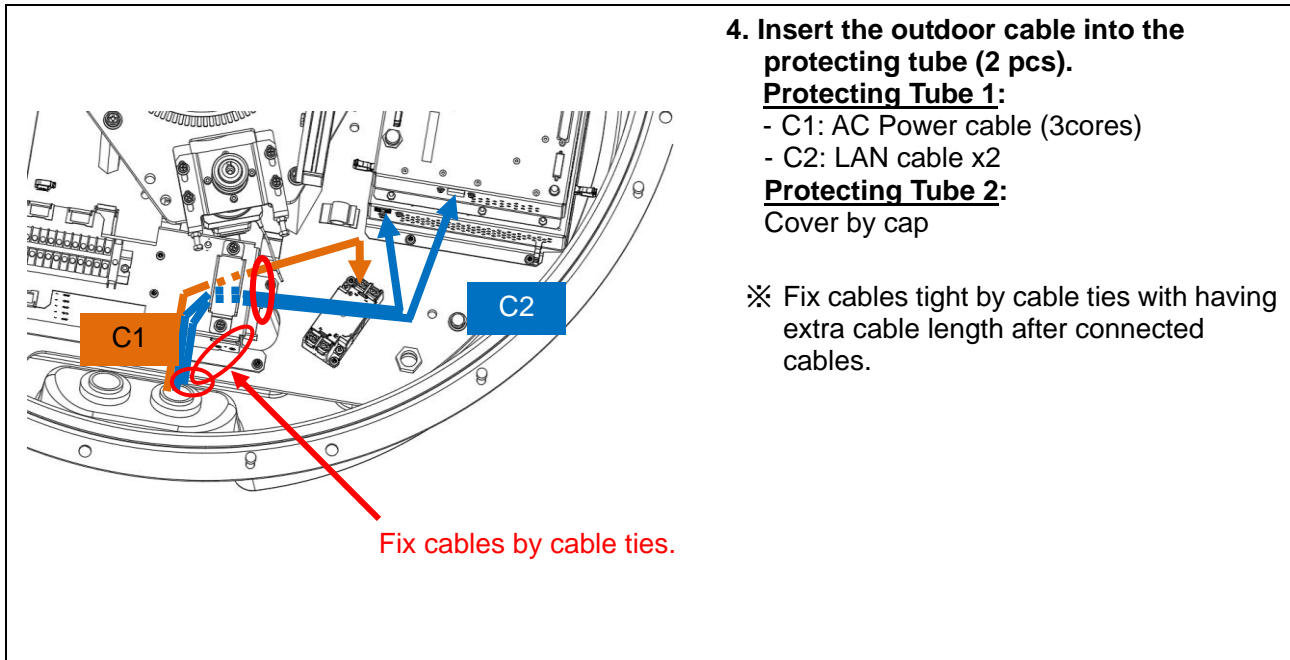
P/L: Phase/Live

N: Neutral

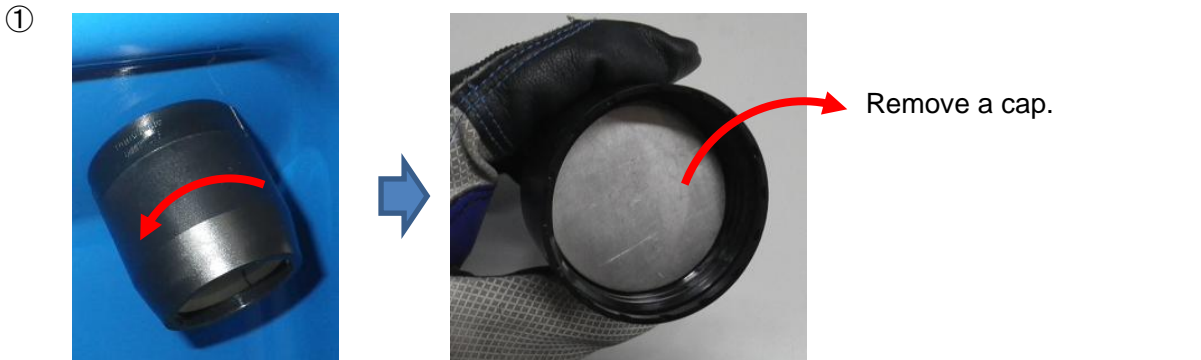
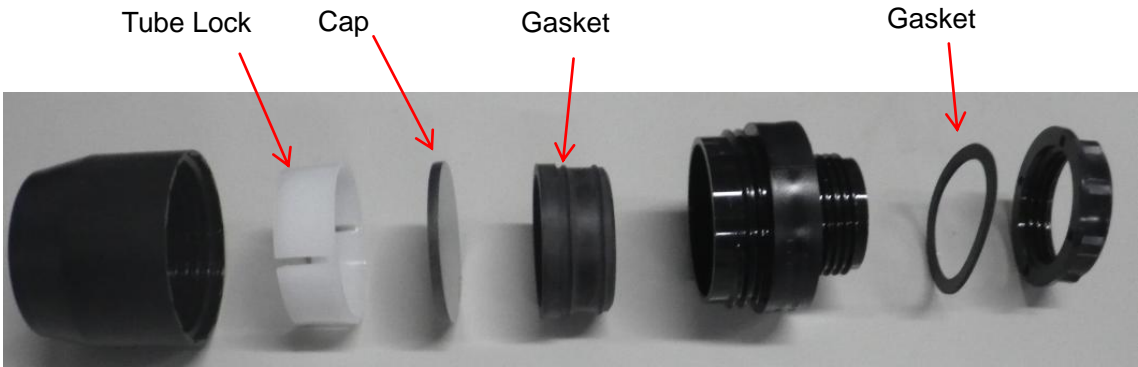
E: Earth / Ground



Power filter

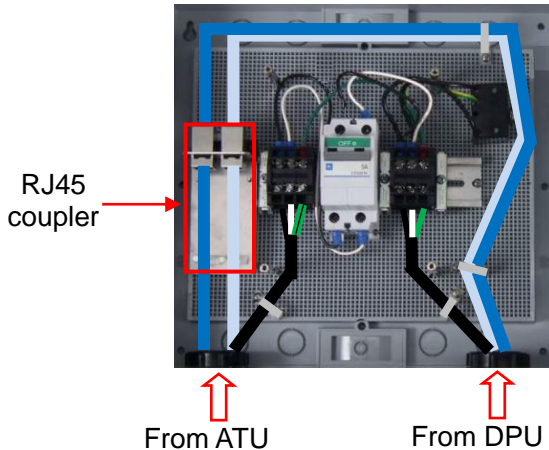


7. Specification of the protecting tube connector.





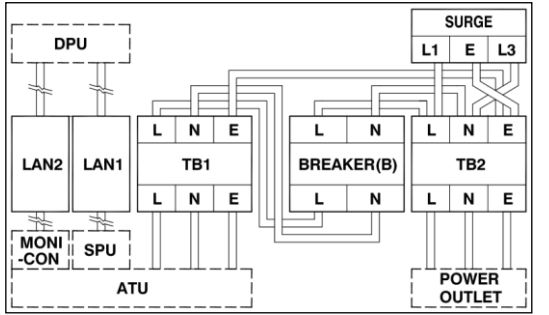
## 5.2. Junction Unit



RJ45 coupler

From ATU

From DPU



### 1. AC power connection

Connect the power cable from ATU to the terminal block (T1-3), and connect the power cable from DPU to the terminal block (T5-7).  
Caution: Do not plug in or turn on the power breaker (DPU side) at this moment.

- Measure the voltage of AC power at the terminal block after turned on or plugged in the main power.
- Reference range: 100V to 240V  $\pm$  10%

<Wire color>

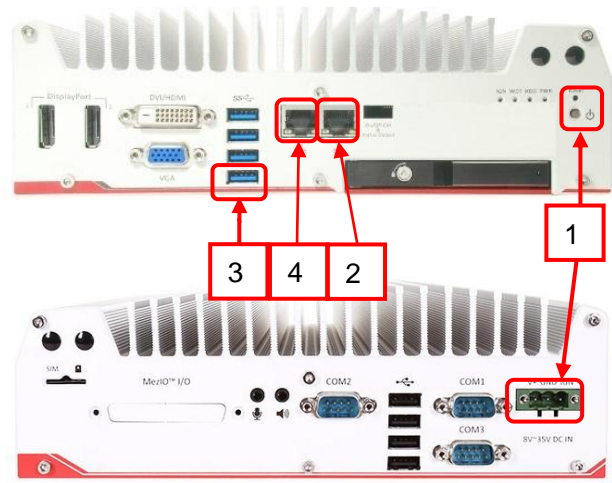
Type		JIS	IWR	US	EU
P/L	+	Black	Black	Black	Brown
N	-	White	White	White or Gray	Blue
GND	FG	Green/ Yellow	Red (Terminal Green)	Green	Green/ Yellow

### 2. LAN connection

Connect LAN cables from ATU to the RJ45 coupler, and connect LAN cables from DPU to the other side of RJ45 coupler with the correct cable.

## 5.3. Data Processing Unit

Sample image of DPU



### 1. Setup Data Processing Unit

- (1) Connect AC power supply cord from electrical outlet to DPU, and turn ON the power. (Turn ON the power of ATU before turn ON the power of DPU)
- (2) Connect LAN cable from DPU to ATU (SPU), and setup IP address of DPU. (192.168.31.110)
- (3) Use USB / LAN adapter if only 2 LAN connectors are mounted. Connect (MONI-CON), and setup IP address of DPU. (192.168.1.80)
- (4) Connect LAN cable from router to DPU for using Internet. (e.g.: 192.168.0.5)

Notice: Do not use the same IP address as ATU.

## 5.4. Open the radome temporary

This is the instruction to open radome temporary by using bolts to fix top radome for maintenance work. One set of tension bolt (4 bolts) is in the rack. Fix these bolts by putting into hole of top and bottom radome and make sure to take a balance as shown below:

Caution: DONOT open a top radome during strong wind. Radome may blow away while releasing bolts.

- ① Loosen all fixed bolts
- ② Twist the top radome to the right to adjust the hole with thru hole and nut insert as shown on image 3.
- ③ Set up nut to make space about 30mm from the end of a stud bolt.
- ④ Insert 6 pcs of stud bolts from thru hole of bottom radome through top radome until M10 nut (that fixed at ③) makes stud bolts stuck.
- ⑤ Put M10 locknut on stud bolt to fix all bolts

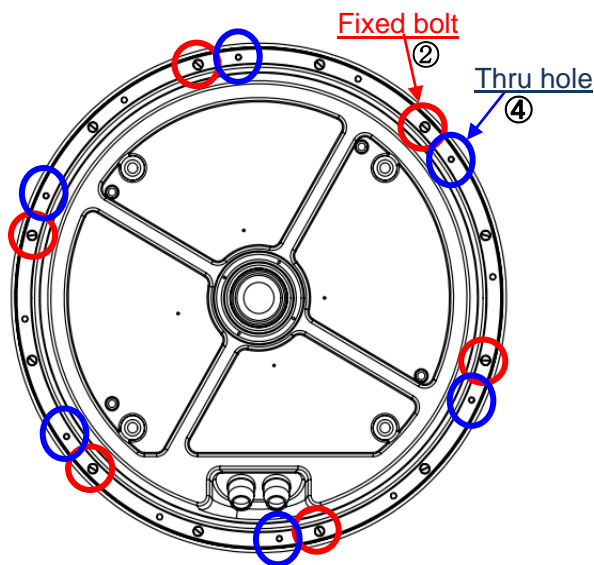


Image 1: Bottom view of radome

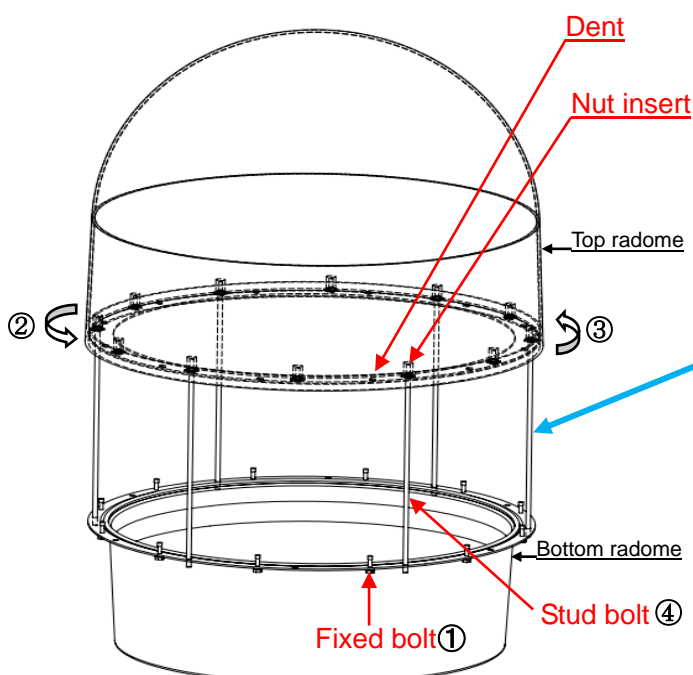
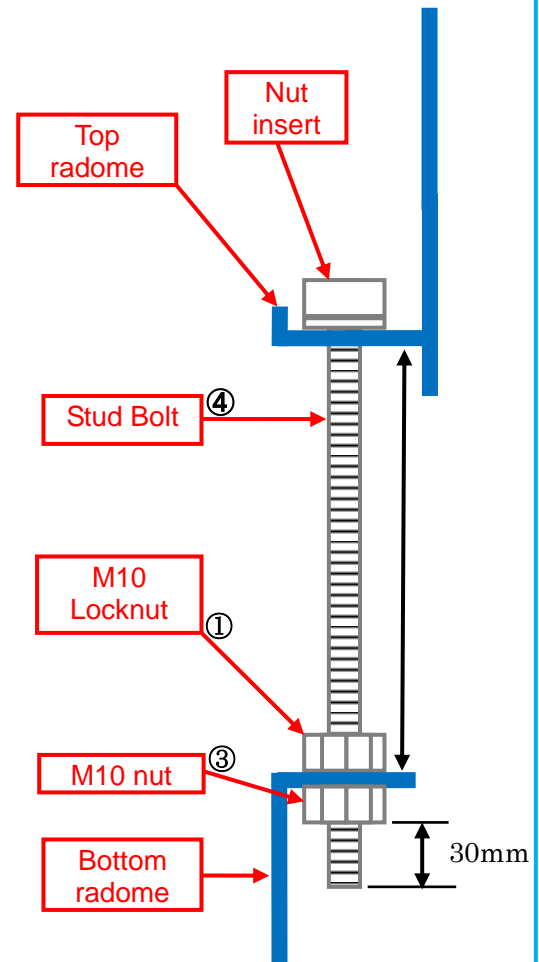


Image 2: Side view of radome

※Tighten up nuts by finger.  
(Do not use any tools)



When adjusting the length of the threaded bolts, be sure that the radome does not lean in any direction.  
Caution: The radome may crack if it leans.

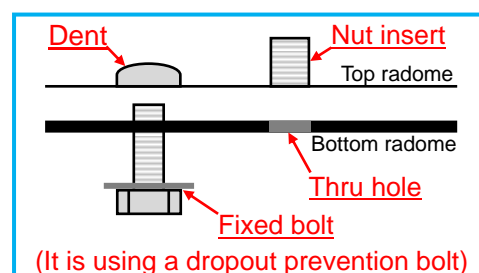
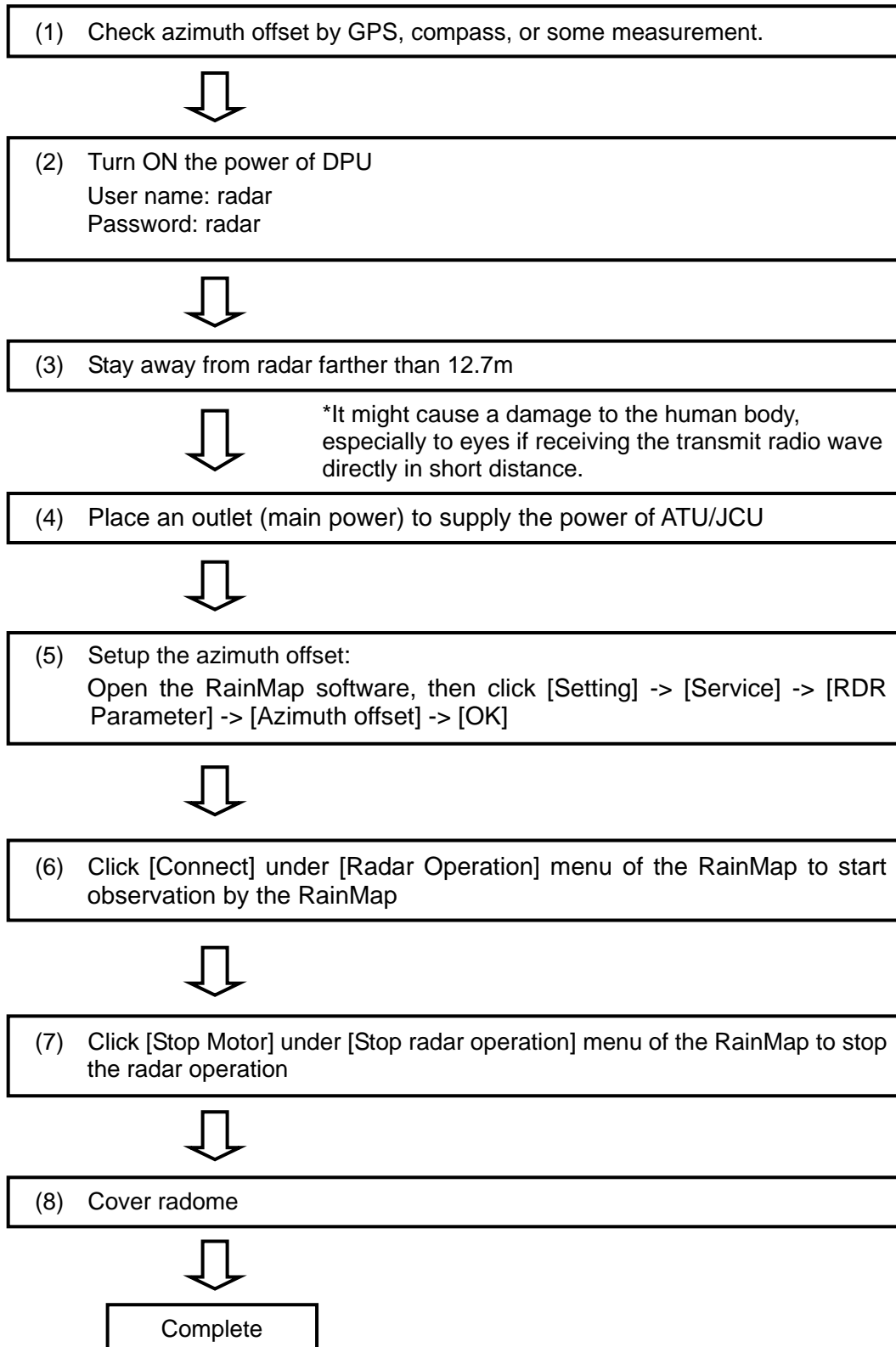


Image 3: Side view of after twisted the top radome to the right

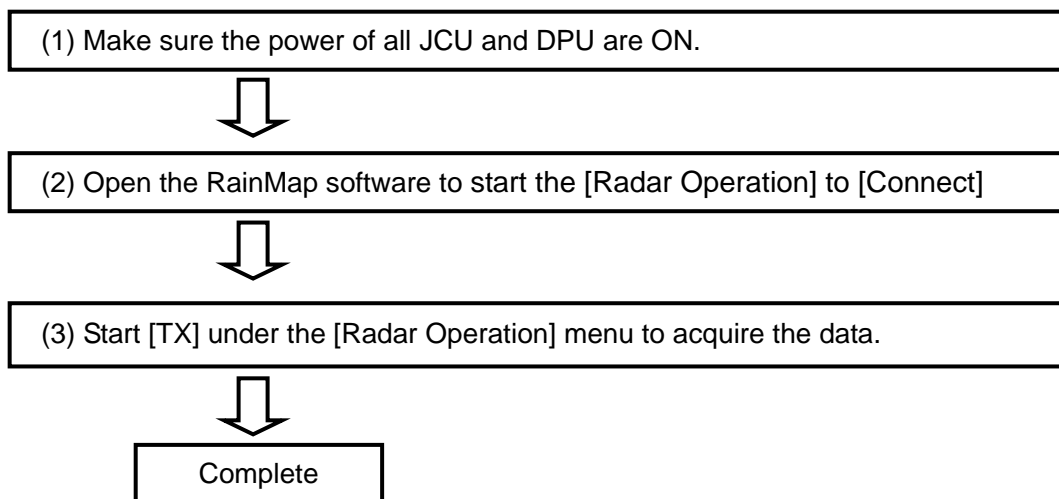
## 6. Operation Test

Follow the step as below:

### 6.1. Before cover (Top part of radome)



## 6.2. After cover (Top part of radome)



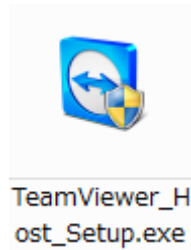
## 7. Install TeamViewer (Remote control management tool)

1. Download the software of TeamViewer Host (For remote server) from the following web site:

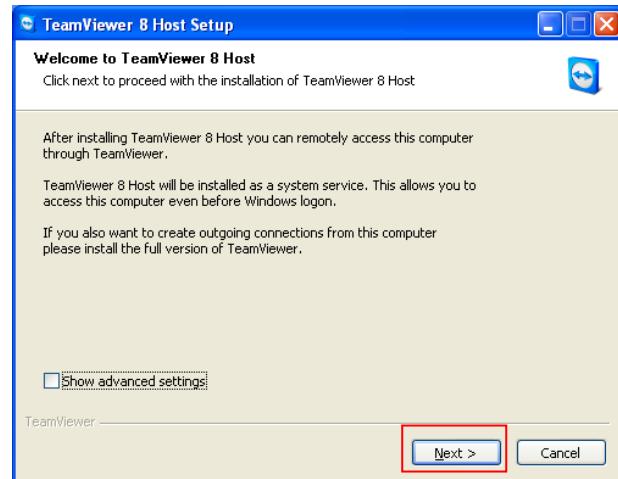
<https://www.teamviewer.com/ja/download/dyngate.aspx#version9>

2. Double click “TeamViewer\_Host\_Setup.exe” to install the software.

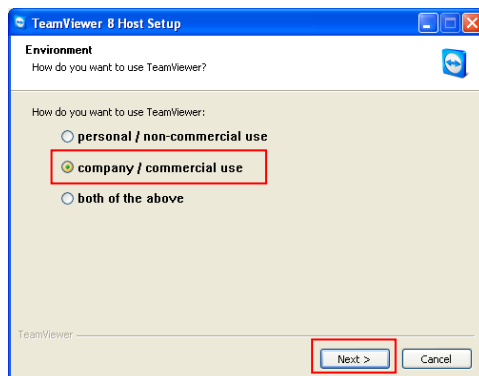
(1) Double click the icon



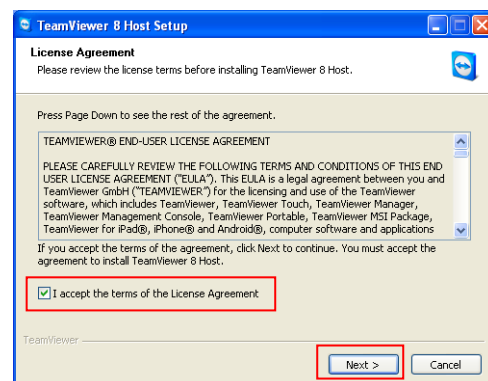
(2) Click [Next]



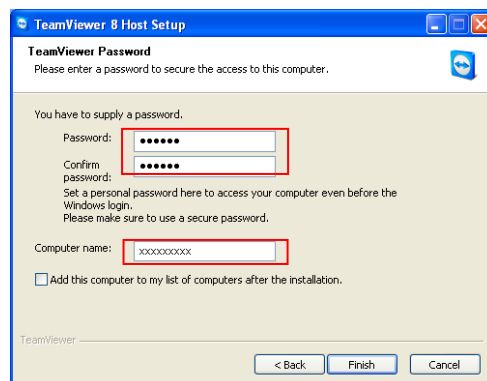
(3) Select “company / commercial use”, and then click [Next]



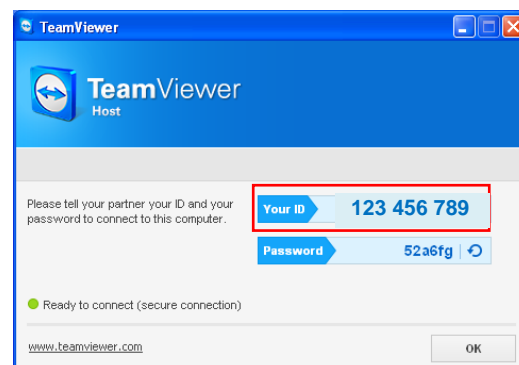
(4) Check on “License Agreement”, and then click [Next]



(5) Make password and computer name  
Password: rmsrms (enter this password)  
Computer name: Enter location’s name  
and then click [Exit]



(6) “Your ID” will be issued automatically.  
(\* Remember this ID)  
And then click [OK]



3. After installed software, please inform “Your ID” to the headquarter of Furuno who is in charge.

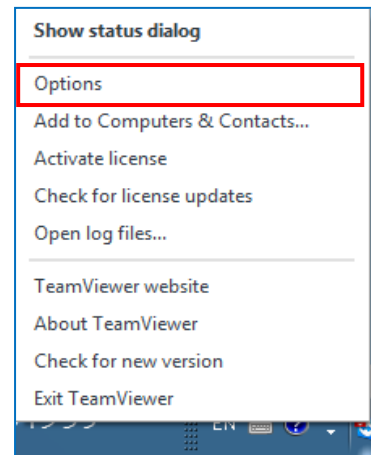
4. Use other PC to confirm the connection of TeamViewer by remote access.



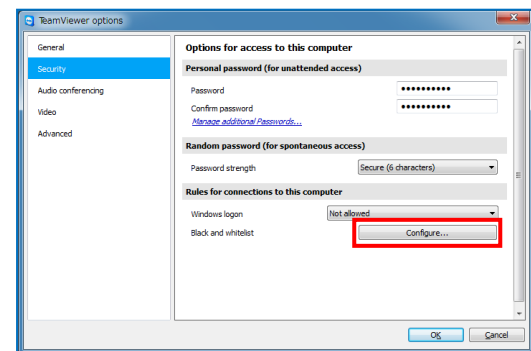
5. The following instruction is Setup security on TeamViewer Host if necessary.

\* Please confirm to a customer and Furuno Headquarter before setup.

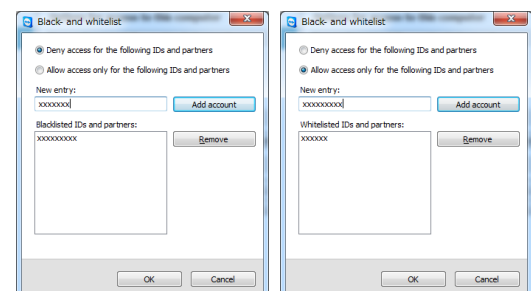
- (1) Right click to the icon of TeamViewer in task bar.
- (2) [TeamViewer options] will indicate a Popup menu on a screen after clicked [Option] from dropdown list of TeamViewer.



- (3) Click [Security] on the right list of [TeamViewer options]
- (4) Click [Configure] of [Black and whitelist] under a menu of [Rules for connections to this computer].



- (5) It could register an opponent ID on the list to whether [Deny access for the following IDs and partners] or [Allow access only for the following IDs and partners] from Popup menu of [Black and whitelist].



## 8. DPU operation

(\*1): Click Menu + press ([Ctrl] + [Alt]) keys simultaneously to indicate the hidden service menu.

### 8.1. File

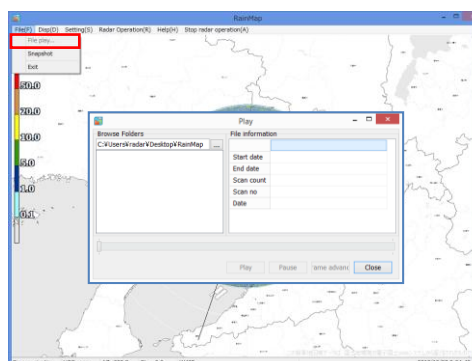
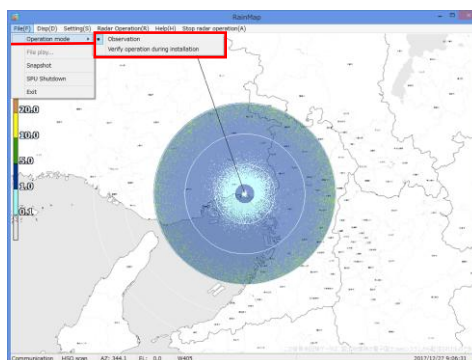
#### 1) Operation mode(\*1):

Do this operation mode after changed some parameters to operate the radar.

- **Observation:**  
Select the entered values at “Setting” menu with regular mode.
- **Verify operation during installation:**  
Change some parameters automatically to verify operation during installation.
- All parameters will set back to previous setting (before this verify operation) if go back to “Observation”

- **File Play:** To play a regular echo recorded file (scn, scnd) with RainPlay software (Refer 8.7.).  
Refer “2) Data Acquisition” on 8.3.1. for setting.

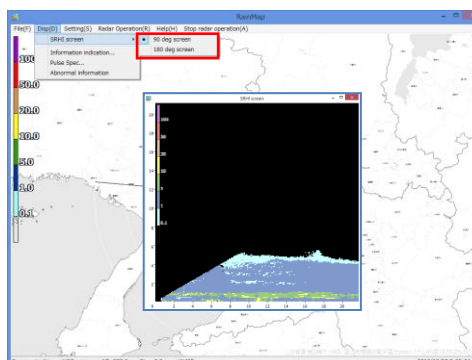
- 2) **Snapshot:** To indicate captured radar screen (jpg).
- 3) **SPU Shutdown:** disuse
- 4) **Exit:** To exit the software of RainMap.



### 8.2. Disp

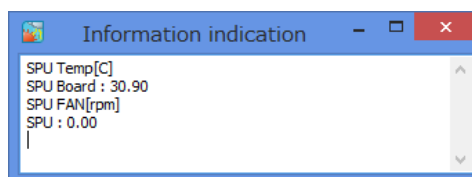
#### 1) SRHI screen:

- 90 deg screen (Indicate the echo of SRHI with 90 degrees on sub screen)
- 180 deg screen (Indicate the echo SRHI with 180 degrees on sub screen )

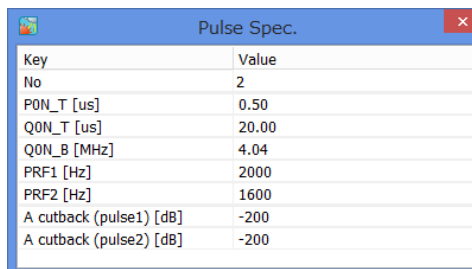


(Image screen of SRHI 90deg.)

- 2) **Information Indication:** Indicate information of specific hardware.



- 3) **Pulse Spec...:** Indicate a specification of current pulse setting.



- 4) **Abnormal information:** Indicate a log of maximum 50 latest errors occurrence with date and time.

## 8.3. Setting

### 8.3.1. Setting

#### 1) Display

##### Display range [km]

Setup an indication range.

##### Display data type

Select an indication of the radar parameter.

- **R [mm/h]:** Intensity of rainfall [mm/h]
- **Zh [dBz]:** Reflection factor of the horizontal polarimetric radar
- **Zh\_corr [dBz]:** Attenuation corrected Zh of the horizontal polarimetric radar
- **V [m/s]:** Reflection factor of the vertical polarimetric radar
- **W [m/s]:** Doppler velocity spectrum width

##### Echo transparency [%]

Setup a Transmittance of the indication echo.

##### Antenna sweep line

Turn ON or OFF a sweep line on screen.

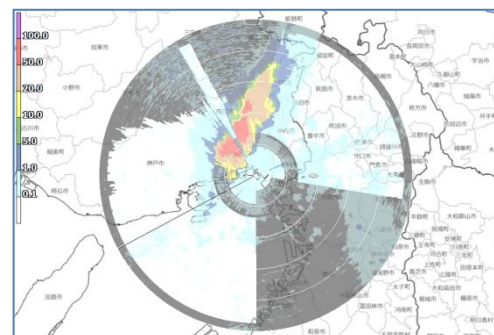
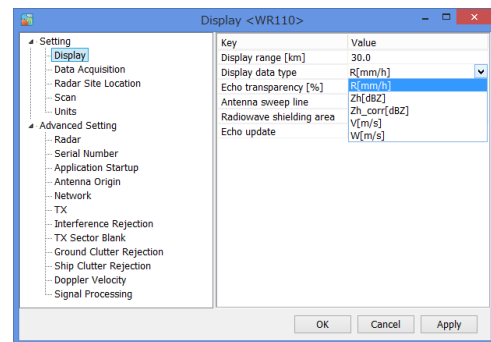
##### Radiowave shielding area

Display OFF or ON the radiowave shielding area on screen. \*Setting file (clip\_RainMap.csv in param folder) is necessary.

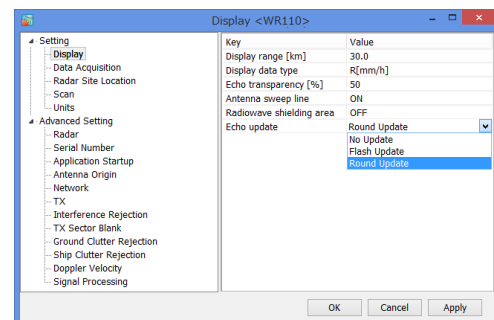
##### Echo update (Service menu)

Select the type to update an echo display:

- No Update
- Flash Update
- Round Update



[ Radiowave shielding images ]



#### 2) Data Acquisition

**Notice: Turn "OFF" all the setting at first.**

##### Screen capture (JPEG)

Turn ON or OFF to capture data on the screen.

##### Screen capture save path

Setup a folder of capture (jpg).

##### Screen capture period

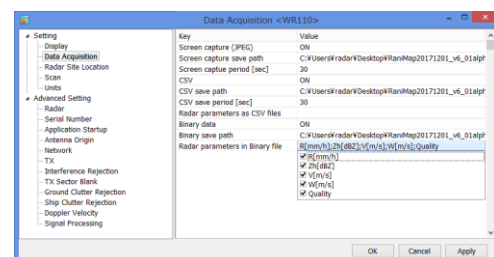
Setup a time interval to save a capture screen.

##### CSV

Turn ON or OFF to save data by CSV.

##### CSV save path

Setup a folder to save the CSV data.



##### CSV save period [sec]

Setup an interval time to save the CSV data.

##### Binary data

Turn ON or OFF to record by binary data.

##### Binary save path

Setup a folder to save the binary data.

### Radar parameters in Binary file

Choose a type of parameter: R [mm/h], Zh [dBz], V [m/s], W [m/s], Quality

## 3) Radar Site Location

### Latitude [deg]

Setup the latitude of the installed point.

### Longitude [deg]

Setup the longitude of the installed point.

### Altitude [m]

Setup the altitude of the installed point.

### Map data path

Setup an indication map for RainMap.

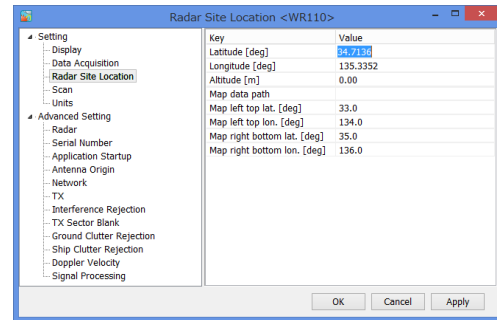
This program treats as the equidistant cylindrical projection.

### Map left top lat [deg]

Setup the latitude of left top corner of Map Image.

### Map left top lon [deg]

Setup the longitude of left top corner of Map Image.



### Map right bottom lat [deg]

Setup the latitude of bottom right corner of Map Image.

### Map right bottom lon [deg]

Setup the longitude of bottom right corner of Map Image.

## 4) Scan set

There are 5 scan patterns that could customize and save a setting.

**Notice: Follow a value of the management list Setup on scan pattern 1.**

### Scan mode

Select the scan mode of antenna.

- **PPI scan (2D data):** [Plan Position Indicator scan]  
It will continuous equiangular 360 degree horizontal rotation mode at a single selectable elevation. It generates 2 dimension data.
- **Sector RHI scan (3D data):** [Sector Range Height Indicator scan] (ref. Fig.1)  
It scans vertically (RHI) slightly move horizontal continuously within a preset azimuth. Elevation range generates 3 dimension rectangular solid angle data. Horizontal data would not be saved.  
It is continue moving to the azimuth direction with clockwise and counter clockwise as 1 set.
- **Volume scan (3D data):** (ref. Fig.2)  
This is the mode to activate PPI scan to change the elevation angle up to 32 steps.  
It starts with the basic time (It comes with VOLUME Period and RainMap time indication).
- **Sector PPI scan (3D data):** [SPPI]: [Sector Plan Position Indicator scan] (ref. Fig.3)  
It scans horizontally within a preset azimuth area while changing elevation based on up to 32 possible values. It generates 3 dimension rectangular solid angle data. Scanning volume of SRHI and SPPI are the same.  
Only the difference is SRHI scan in vertical plane and SPPI scans in horizontal plane.

### PPI scan:

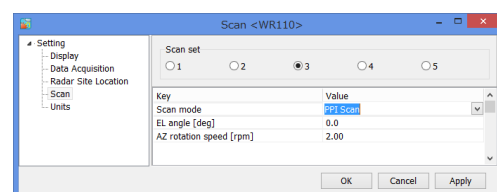
#### EL angle [deg]

Setup an angle of antenna's elevation during PPI mode.

#### AZ rotation speed [rpm]

Setup a rotation speed of azimuth in rotation per minutes (rpm).

Parameters affect only to PPI mode



**Sector RHI scan:****EL rotation speed [rpm]**

Setup an elevation speed of Sector RHI.

**AZ start angle [deg]**

Setup an angle of start azimuth range.

**AZ end angle [deg]**

Setup an angle of end azimuth range.

**AZ step angle [deg]**

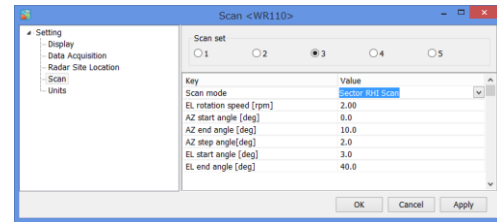
Setup a quantity of antenna rotation while changing an angle of azimuth.

**EL start angle [deg]**

Setup an angle of elevation start to observe volume.

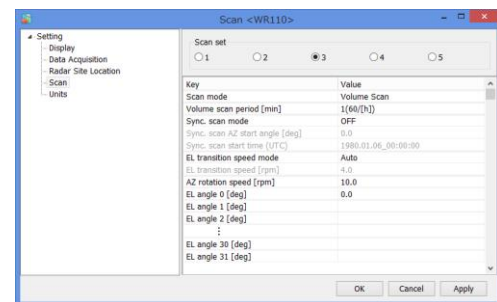
**EL end angle [deg]**

Setup an angle of elevation end to observe volume.

**Volume scan:****Volume scan period [min]**

Select a periodic volume scan movement from 1(60/[h]) / 2(30/[h]) / 3(20/[h]) / 4(15/[h]) / 5(12/[h]) / 6(10/[h]) / 10(6/[h]) / 12(5/[h]) / 15(4/[h]) / 20(3/[h]) / 30(2/[h]) / 60(1/[h])

E.g. Volume scan will activate every 2 minutes if select 2/30/(H). (It turns 30 times per hour) and measurement start time will be; 00, 02, 04,..., 58 seconds on Data Processing Unit.

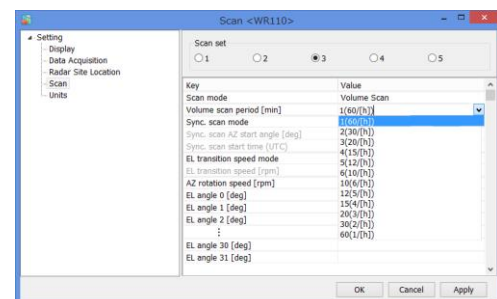
**Sync. scan mode:**

Turn ON or OFF to operate antenna synchronize scan when using 2 or more radars.

Notice: It can use only when the optional device has been installed.

- **Sync. scan AZ start angle:**

Setup the azimuth start angle of synchronize scan.  
e.g.: Stagger azimuth angle to 90 degrees against the opponent radar when using 2 radars.



- **Sync. scan start date/time (UTC):**

Setup the time of starting synchronize scan.

Note: This is GPS time therefore it might be different as the time shows on RainMap screen.

**EL transition speed mode:**

Select speed mode of elevation “Auto” or “Manual”.

- **Auto:** RainMap will adjust a speed of radar elevation automatically.
- **Manual:** Input speed value by hand.

**EL transition speed speed [rpm]**

Setup a rotation speed of elevation direction during elevation change in volume scan (Horizontal Sequence) observation.

Rotation speed of elevation direction = [volume scan elevation moving direction of rotation speed] + [volume scan elevation movement difference of rotation speed]

Notice: [volume scan elevation moving direction of rotation speed]  $\geq$  [volume scan elevation movement difference of rotation speed]

**AZ rotation speed [rpm]**

Setup the volume azimuth rotation speed for each elevation.

**EL angle 0 – 31 [deg]**

Setup each elevation variation, up to 32 different values. It automatically sorts in ascending order of elevation setting value.

**Sector PPI scan:**

**AZ rotation speed [rpm]**

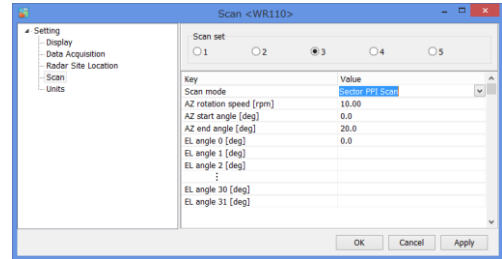
Setup an azimuth rotation speed at fixed azimuth angel.

**AZ start angle [deg]**

Setup the preset start azimuth range.

**AZ end angle [deg]**

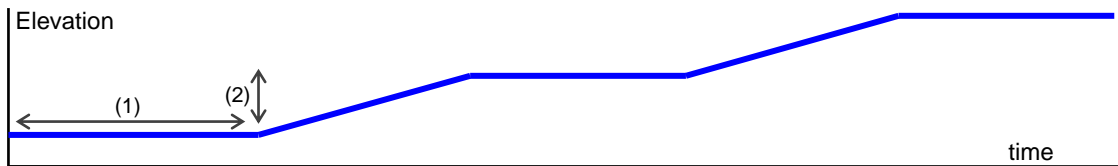
Setup the preset end azimuth range.



**EL angle 0 – 31 [deg]**

Setup each scanning elevation variable, up to 32 different values. It automatically sorts in ascending order of elevation setting value.

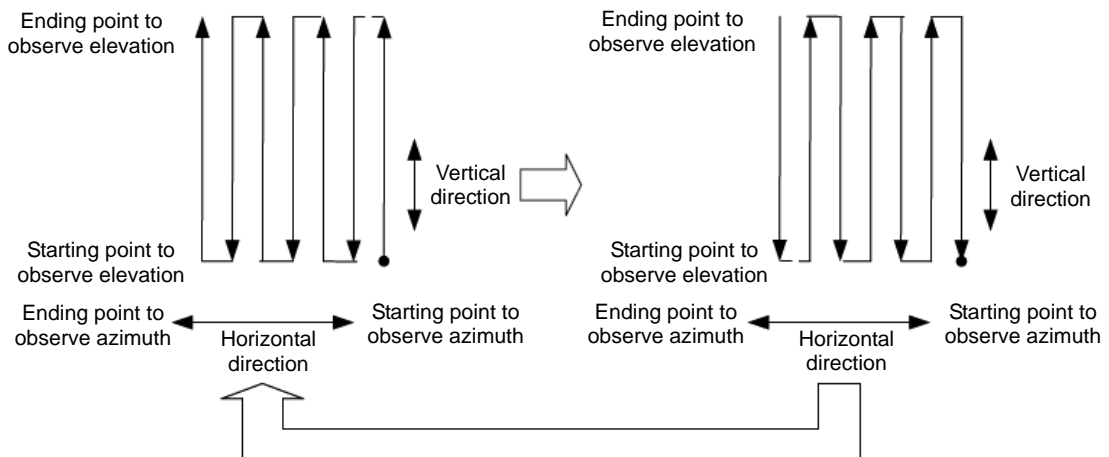
**Table 1.**



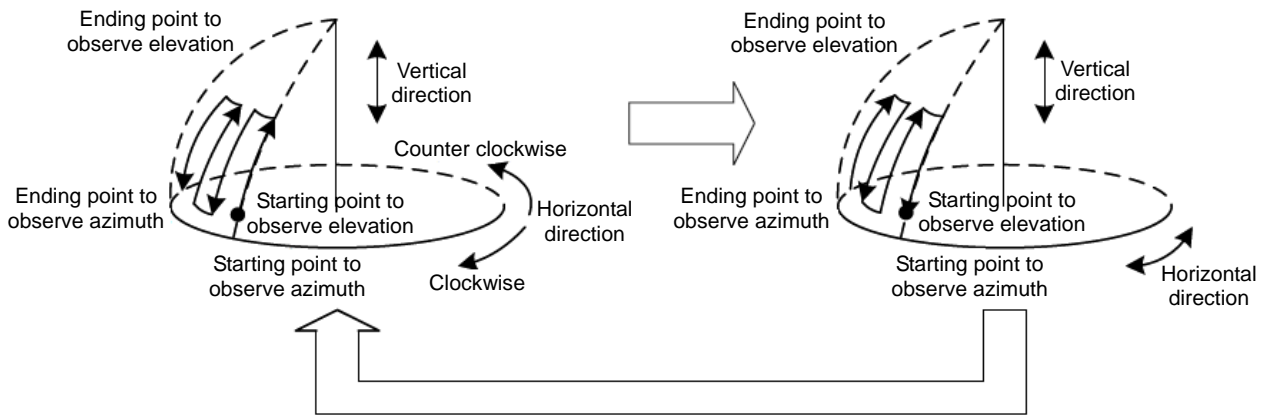
- (1) AZ rotation speed [rpm]
- (2) EL transition speed [rpm]

**Table 2. Rotation speed range**

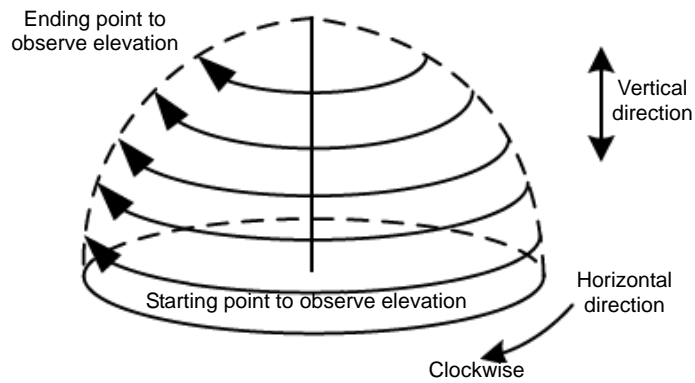
Menu	Range
EL rotation speed	0.5 to 6.0 rpm
EL transition speed	0.5 to 6.0 rpm
AZ rotation speed	0.5 to 16.0 rpm



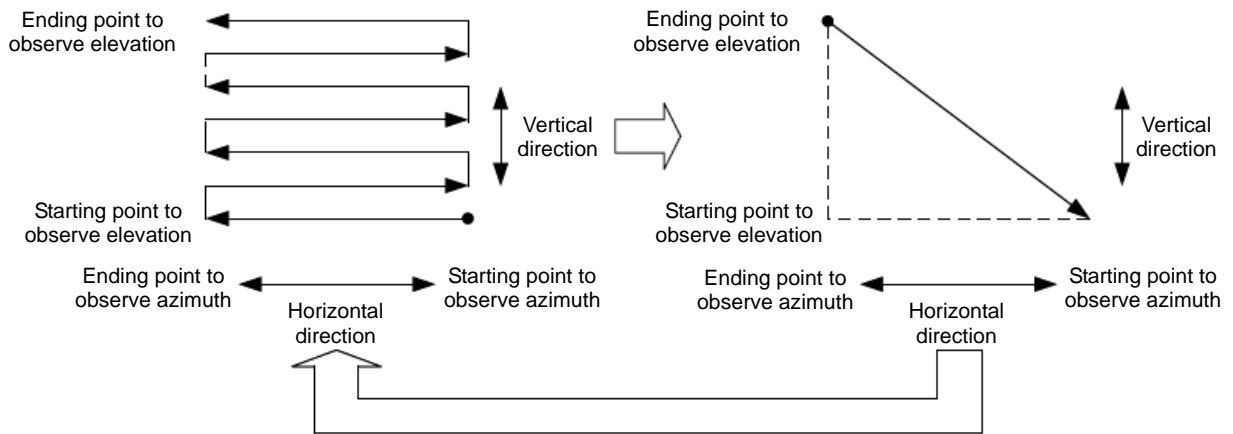




**Figure 1. Sector RHI scan mode**



**Figure 2. Volume scan mode**

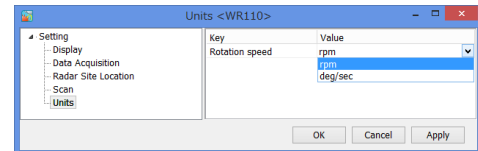


**Figure 3. Sector PPI Scan mode**

## 5) Units

### Rotation speed

Select a type of indication on rotation speed.



## 8.3.2. Service

Press [Ctrl] + [Alt] and click [Setting] simultaneously to indicate service menu.

Service menu has two types:

1. Maintenance setting: Regular menu for maintenance service engineer.
2. Factory setting: Adjust the setting of installed station use only for installation engineer.

**Notice: Follow the management list Setup all values.**

## 1) Radar

Disuse

## 2) Serial Number

### Serial number

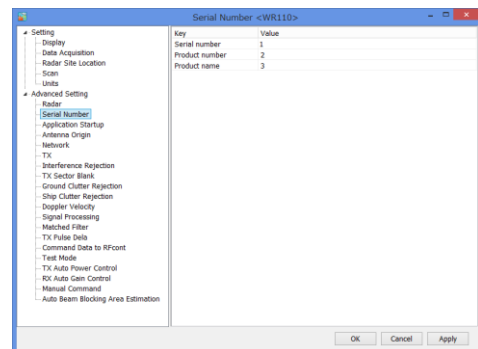
Enter a serial number of product.

### Product number

Enter a product number.

### Product name

Enter a name of product.



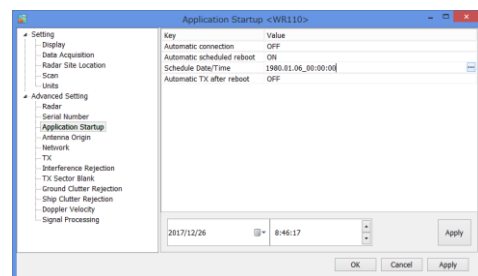
## 3) Application Startup

### Automatic connection

Turn ON or OFF for connecting to the radar automatically after startup RainMap.

### Automatic schedule reboot

Turn ON or OFF for using schedule to reboot the radar automatically.



### Schedule Date/Time

Setup the schedule year/month/date/time(hh/mm/ss) to restart RainMap and PC automatically.

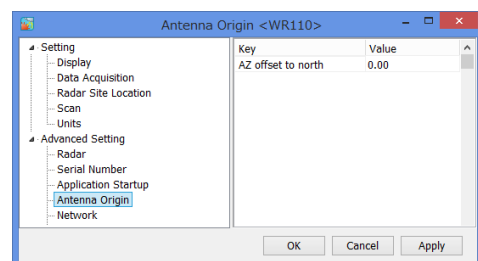
### Automatic TX after reboot

Turn On or OFF to Transmit after rebooting the radar automatically.

## 4) Antenna Origin

### AZ offset to north

Setup an azimuth offset angle from origin of radar.



## 5) Network

### SPU type

Select and setup the SPU channel of the ATU.

Manual / Auto (Automatically select type of radar either WR110 or WR2120)

### Command transfer IP

Confirm the IP address of command transfer.

■ Constant value: 192.168.31.101

### Command transfer port

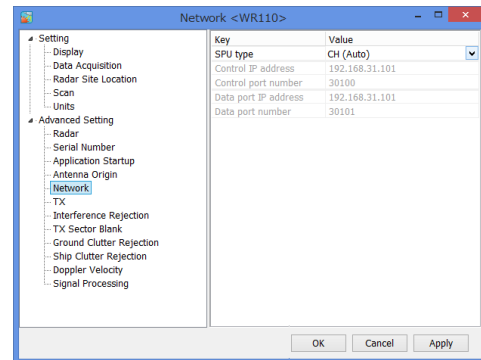
Confirm the port number of command transfer.

■ Constant value: 30100

### Data transfer IP

Confirm the IP address of data transfer.

■ Constant value: 192.168.31.101



### Data transfer port

Confirm the port number of data transfer.

■ Constant value: 30101

## 6) TX

### PRF pattern

It uses for setting multiple radars.

Select a type of preference pattern 1 to 4 that registered in the preference folder.

### Pulse set

Select pulse number from 1 to 8 to choose the setting.

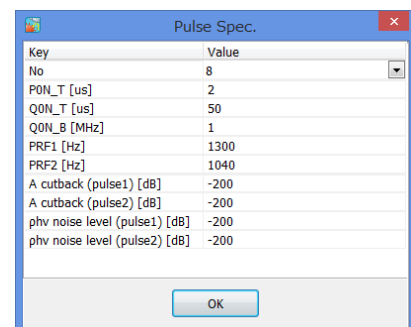
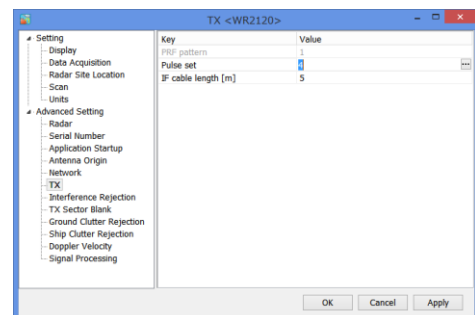
Each PRF pattern number has different pulse specification. Values will adjust automatically by using noise measurement. Furthermore values of A cutback and phv noise level could manually change.

Display range: No.1 = 30km, No.2 = 30km

No.3 = 50km, No.4 = 70km

No.5 = 50km, No.6 = 30km

No.7 = 50km, No.8 = 70km

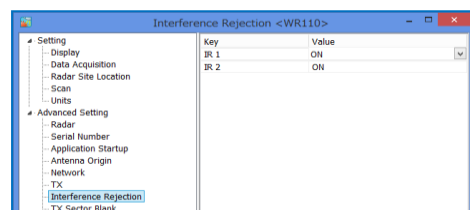


## 7) Interference Rejection

### IR 1

Turn ON or OFF the IR 1. Basically turn both ON to reject interference as well. IR 1 will reject the matched filter (pulse compression).

**Note:** This is not a level of strength to reject interference.



## 8) TX Sector Blank

### Blank area 1 and 2

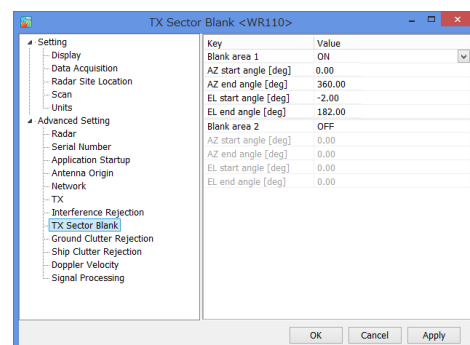
Turn ON or OFF a sector blank

### AZ start angle [deg]

Setup the starting angle of azimuth to make a sector blank.

### AZ end angle [deg]

Setup the ending angle of azimuth to make a sector blank.



**EL start angle [deg]**

Setup the starting angle of elevation to make a sector blank.

**EL end angle [deg]**

Setup the ending angle of elevation to make a sector blank.

**9) Ground Clutter Rejection****GCR**

Turn 1, 2, or OFF Select whether to remove ground clutter as a target if moving speed is lower than setting speed.

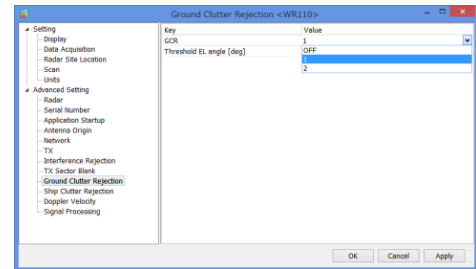
1: Reject it by using echo data.

2: Reject it by using Reference folder (scr)

OFF: Remain a ground.

**Threshold EL angle [deg]**

Setup the elevation angle of threshold.

**10) Ship Clutter Rejection****SCR**

Turn 1, 2, or OFF Select whether to remove ship clutter as a target if moving speed is lower than setting speed.

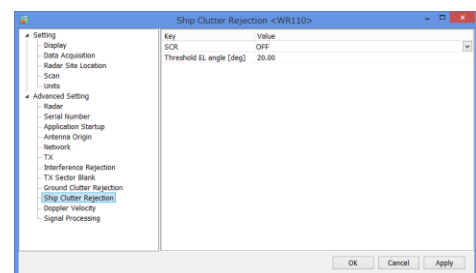
1: Reject it by using echo data.

2: Reject it by using Reference folder (scr)

OFF: Remain a ground.

**Threshold EL angle [deg]**

Setup the elevation angle of threshold.

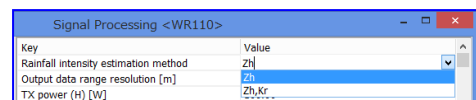
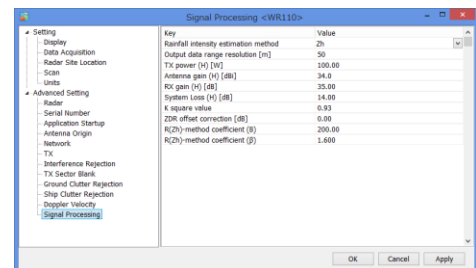
**11) Doppler Velocity****Doppler Velocity Calculation**

Turn ON or OFF to calculate a Doppler velocity.

**12) Signal Processing****Rainfall intensity estimation method**

Select a type of method of Rainfall intensity estimation.

- **Zh**: Use horizontal amplitude information only.
- **Zh,Kr**: Zh is calculated from the value that corrected rain decay by the amplitude.

**Output data range resolution [m]**

Enter an output data range of resolution

**TX power (H) [W]**

Enter a value of horizontal power of TX.

**Antenna gain (H) [dBi]**

Enter a value of horizontal antenna gain

**RX gain (H) [dB]**

Enter a value of horizontal RX gain.

**System Loss (H) [dB]**

Enter a value of horizontal system loss.

**K square value**

Enter a value of K square.

**R(Zh)-method coefficient (B)**

Enter a value of R(Zh)-method coefficient "B"

**R(Zh)-method coefficient (beta)**

Enter a value of R(Zh)-method coefficient "beta"

### 8.3.3. Precipitation estimates methods:

#### Zh method

1. Use standard Marshal Palmer equation;  $\text{Rain}(Zh) = \left(\frac{1}{B}\right)^{\frac{1}{\beta}} \times 10^{\frac{Zh}{10 \times \beta}}$
2. Parameters "B" and "β" are able to set by maintenance interface. Default value of "B" is 200, and "β" is 1.6.
3. Zh unit is using mm<sup>6</sup>/mm.

#### Zh, Kr method

1. Calculate rainfall intensity  $R_{zh}$  from Zh using the same method as "Zh method".
2. Calculate attenuation correction parameter  $Kr(r)$  from R
3. Calculate rainfall intensity (Rain) from Zh + Kr
4. Point below threshold data of B-cutback will be 0.

$$R_{zh} = \left(\frac{1}{B}\right)^{\frac{1}{\beta}} \times 10^{\frac{Zh}{10 \times \beta}}$$

$$Kr(r) = 0.013 \times \int_0^r R_{zh}^{1.15} dr$$

$$\text{Rain}(Zh + Kr) = \left(\frac{1}{B}\right)^{\frac{1}{\beta}} \times 10^{\frac{Zh+Kr}{10 \times \beta}}$$

### 8.3.4. Management list

The management list would be attached with the RainMap to every location for setting.

- Please setup some values that belong to the location.
- Default value of each equipment is listed on a separate sheet.
- Key & Value with yellow column would indicate during factory setting.
- Gray column means that item would be masked by a switch.

This manual is belonging to the following software version:

- RainMap v06.01
- RainPlay v1.10

## 1. Setting

Major menu	Medium menu	Minor menu	Input value [unit]	
Setting	Display	Display range [km]	0.5 - 50.0 [0.1]	
		Display data type	R [mm/h] / Zhh [dBZ] / Zhh_corr [dBZ] / V [m/s] / W [m/s]	
		Echo transparency [%]	0 - 100 [1]	
		Antenna sweep line	OFF / ON	
		Radiowave shielding area	OFF / 1 / 2	
		Echo update	No Update / Flash Update / Round Update	
	Data Acquisition	Screen capture (JPEG)	OFF / ON	
		Screen capture save path	C:\<exe pass>\RecData\capture	
		Screen capture period [sec]	0 - 3600 [1]	
		CSV	OFF / ON	
		CSV save path	C:\<exe pass>\RecData\csv	
		CSV save period [sec]	0 - 3600 [1]	
		Radar parameters as CSV files	R[mm/h] / Zhh[dBz] / V[m/s] / W[m/s]	
		Binary data	OFF / ON	
		Binary save path	C:\Documents and Settings\USER\Desktop\RecData\binary	
		Radar parameters in Binary file	R[mm/h] / Zhh[dBz] / V[m/s] / W[m/s] / Quality	
	Radar Site Location	Latitude [deg]	-90.00000 - 90.00000 [0.00001]	
		Longitude [deg]	-90.00000 - 90.00000 [0.00001]	
		Altitude [m]	0.00 - 100000.00 [0.01]	
		Map data path	C:\<exe pass>\RainMap	
		Map left top lat. [deg]	-90.00000 - 90.00000 [0.00001]	
		Map left top lon. [deg]	-90.00000 - 90.00000 [0.00001]	
		Map right bottom lat. [deg]	-90.00000 - 90.00000 [0.00001]	
		Map right bottom lon. [deg]	-90.00000 - 90.00000 [0.00001]	
	Scan	ScanMode		PPI Scan / Sector RHI Scan / Volume Scan / Sector PPI Scan
		PPI Scan	EL angle [deg]	-2.0 - 90.0 [0.1]
			AZ rotation speed [rpm]	0.50 - 16.00 [0.01]
		Sector RHI Scan	EL rotation speed [rpm]	0.50 - 6.00 [0.01]
			AZ start angle [deg]	0.0 - 360.0 [0.1]
			AZ end angle [deg]	0.0 - 360.0 [0.1]
			AZ step angle [deg]	0.0 - 360.0 [0.1]
			EL start angle [deg]	-2.0 - 182.0 [0.1]
		Volume Scan	EL end angle [deg]	-2.0 - 182.0 [0.1]
			Volume scan period [min]	1(60[h]) / 2(30[h]) / 3(20[h]) / 4(15[h]) / 5(12[h]) / 6(10[h]) / 10(6[h]) / 12(5[h]) / 15(4[h]) / 20(3[h]) / 30(2[h]) / 60(1[h])
			Sync. scan mode	OFF / ON
			Sync. scan start angle [deg]	0.0 - 360.0 [0.1]
			Sync. scan start time (UTC)	YYYY.MM.DD_HH:MM:SS
			EL transition speed mode	Auto / Manual
			EL transition speed [rpm]	0.5 - 6.0 [0.1]
			AZ rotation speed [rpm]	0.5 - 16.0 [0.1]
			EL angle 0 [deg]	-2.0 - 90.0 [0.1]
			EL angle 31 [deg]	-2.0 - 90.0 [0.1]
		Sector PPI Scan	AZ rotation speed [rpm]	0.5 - 16.0 [0.1]
			AZ start angle [deg]	0.0 - 360.0 [0.1]
			AZ end angle [deg]	0.0 - 360.0 [0.1]
			EL angle 0 [deg]	-2.0 - 90.0 [0.1]
	EL angle 31 [deg]		-2.0 - 90.0 [0.1]	
Units	Rotation speed		rpm / deg/sec	

Note: Gray mark item will be shown when using service menu.



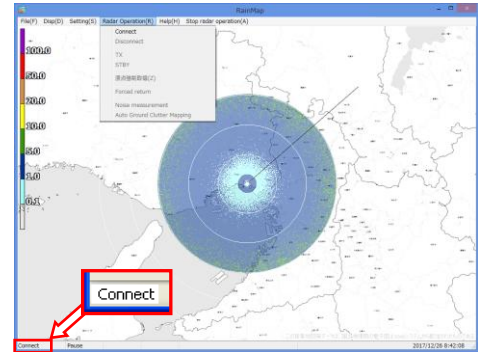
## 2. Service

Service menu will come out when pressed [Alt]+[Ctrl]keys and clicked [Setting] menu simultaneously.

Major menu	Medium menu	Minor menu	Input value [unit]		
Service	Radar	-	-		
	Serial Number	Serial number	xxxxxxxxxxxxx (no limit)		
		Product number	xxxx (4 digit)		
		Product name	xxxxxxxxxxxxx (no limit)		
	Application Startup	Automatic connection	OFF / ON		
		Automatic scheduled reboot	OFF / ON		
		Schedule Date/Time	YYYY.MM.DD_HH:MM:SS		
		Automatic TX after reboot	OFF / ON		
	Antenna Origin	AZ offset to north	0.00 - 360.00 [0.01]		
	Network	SPU type	Manual / CH (Auto)		
		Control IP address	xxx.xxx.xxx.xxx		
		Control port number	30100, 49152 - 65535 [1]		
		Data port IP address	xxx.xxx.xxx.xxx		
		Data port number	30101, 49152 - 65535 [1]		
	TX	Pulse spec.	PRF pattern	1 - 4 [1]	
			Pulse set / No	1 - 8 [1]	
			PON_T [us]	Values are fixed with the pulse number	
			QON_T [us]		
			QON_B [MHz]		
			PRF1 [Hz]		
			PRF2 [Hz]		
			A cutback (pulse1) [dB]		-100.00 - 0.00 [n,0.01]
			A cutback (pulse2) [dB]		-100.00 - 0.00 [n,0.01]
			phv noise le1el (pulse1) [dB]		-100.00 - 0.00 [n,0.01]
	phv noise le1el (pulse2) [dB]	-100.00 - 0.00 [n,0.01]			
	Interference Rejection	IR 1	OFF / ON		
		Blank area 1	OFF / ON		
	TX Sector Blank	AZ start angle [deg]	0.00 - 360.00 [0.01]		
		AZ end angle [deg]	0.00 - 360.00 [0.01]		
		EL start angle [deg]	-2.00 - 182.00 [0.01]		
		EZ end angle [deg]	-2.00 - 182.00 [0.01]		
		Blank area 2	OFF / ON		
		AZ start angle [deg]	0.00 - 360.00 [0.01]		
		AZ end angle [deg]	0.00 - 360.00 [0.01]		
		EL start angle [deg]	-2.00 - 182.00 [0.01]		
		EZ end angle [deg]	-2.00 - 182.00 [0.01]		
		Ground Clutter Rejection	GCR	OFF / 1 / 2	
	Threshold EL angle [deg]		-2.00 - 90.00 [0.01]		
	Ship Clutter Rejection	SCR	none		
		Threshold EL angle [deg]	-2.00 - 90.00 [0.01]		
	Doppler Velocity	Doppler Velocity	OFF / ON		
	Signal Processing	Rainfall intensity estimation method	Zh / Zh,Kr		
Output data range resolution [m]		50 - 1000 [1]			
TX power (H) [W]		50.00 - 150.00 [0.01]			
Antenna gain (H) [dBi]		30.0 - 40.0 [0.1]			
RX gain (H) [dB]		0.00 - 128.00 [0.01]			
System Loss (H) [dB]		0.00 - 50.00 [0.01]			
K square value		0.00 - 5.00 [0.01]			
R(Zh)-method coefficient (B)		50.00 - 5000.00 [0.01]			
R(Zh)-method coefficient (B)	0.500 - 10.000 [0.001]				

## 8.4. Radar Operation

1. Turn on the power of Data Processing Unit
2. Software will start automatically.
3. Click [Connect] button to start radar operation.  
[Connect] will be indicated in the left bottom.
4. Click [TX] button to start observation.
5. Radar echo will indicate with rotate scanning line after the message of [Initializing] on the screen.
6. Click [STBY] button to stop observation.
7. Click [Disconnect] button to stop connecting with radar.



### Notice:

The following command could not operate without connecting radar:

- Radar operation (Connect/Disconnect, TX/STBY)
- Screen capture

Cold start in the cold weather:

If initialization (transit to detect the origin) is failed right after turned on the power of ATU in the cold weather, leave it for a while with the power on, then try TRX again.

### 1) Reset the antenna origin

Force to initialize the antenna to acquire the direction of the origin (zero point) when some kind of elevation failure occurs.

### 2) Forced return<sup>(\*)</sup>

Force to reboot the ATU only when error occurs for restoration.

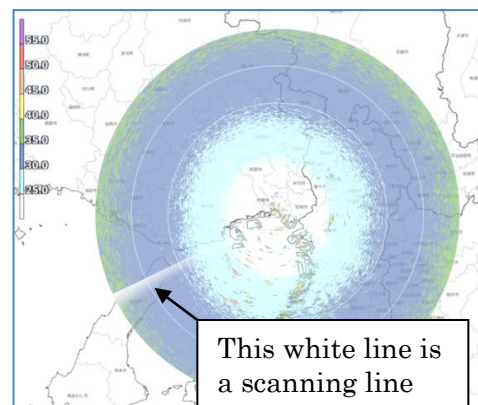
### 3) Noise measurement<sup>(\*)</sup>

(To indicate it by pressing Crt + Alt + [Radar Operation] simultaneously)

Click [Noise measurement] to adjust a noise level after clicked [Connect]. It will start to receive radar and stop automatically after adjustment and overwrite into param file data (in a separate file).

**Caution: DONOT operate it thoughtlessly because present optimum data might be gone.**

**Good to measure during sunny day.**



### 4) Auto Ground Clutter Mapping<sup>(\*)</sup>

This ground clutter mapping is using the function of volume scan mode. It is good to measure during sunny day.

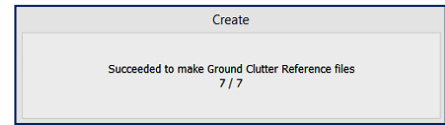
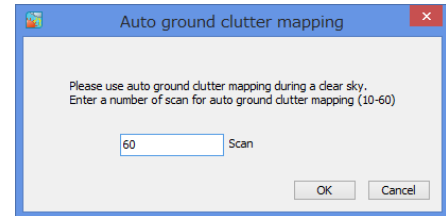
Please setup the following:

- Setting -> Acquisition -> Multiple parameter output : ON
- Setting -> Service -> TRX -> Echo data mode : Multiple Parameter
- Setting -> Service -> Ground Clutter Rejection -> Ground clutter rejection: 1

Pressing Crt + Alt + [Radar Operation] simultaneously and click [Auto Ground Clutter Mapping] to start measure after above setup.

32 elevations can be possible Setup by Volume scan mode for measuring elevation in one time.

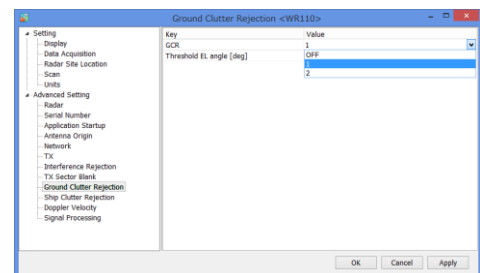
- (1) Setup a number of times for scenario: Setup a number of time to scan from 10 to 60 (Large scan number could receive higher accuracy).
- (2) Confirm to start measurement: Click [OK] to begin when it is ready. Click [Cancel] to quit measurement.
- (3) It will be completed to measure ground clutter after created a reference map(scr). Restart RainMap after succeeded the measurement (Refer to the right sample screen).



Data format of “scr” file is same as “scn” file when measured.

- e.g.) It may take approx. 6 hours to complete measurement and create reference map data.
- Setup the maximum volume scan period of 4(15/[h]) [min] on volume scan mode.
  - Setup volume scan setting elevation from 0 to 5 [deg]
  - Setup 10.00 [rpm] on Antenna rotation speed of RDR Parameter.
  - Select “1” on ground clutter removal.
  - Setup 3.00 on Filter constant of ground clutter reference auto processing.
  - Setup the maximum scan measurement of 60 when popup menu indicate while starting ground clutter measurement.

It may take time to start RainMap because of saving a new measured data into RainMap. Ground clutter reference file can be used only when a setting of ground clutter rejection is “2”.

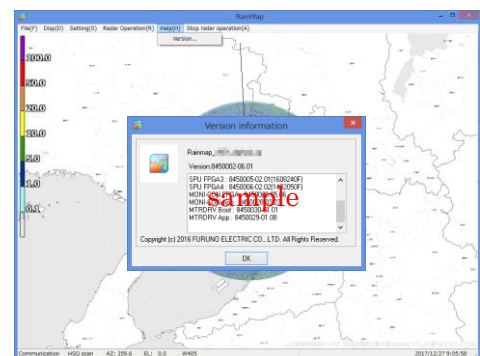


## 8.5. Help

### Version

Indicate the version of software and connecting devices.

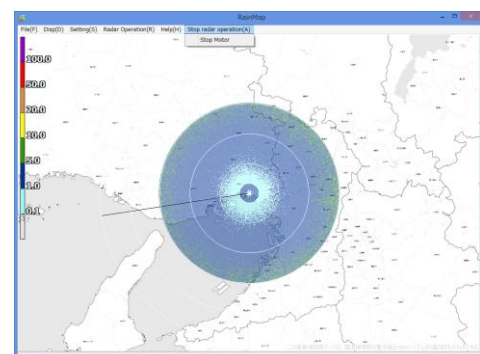
(RainMap, SPU FPGA1-4, MONI-CON FPGA, MONI-CON boot, MONI-CON App, MTRDRV Boot, MTRDRV App)



## 8.6. Stop radar operation

### Stop Motor

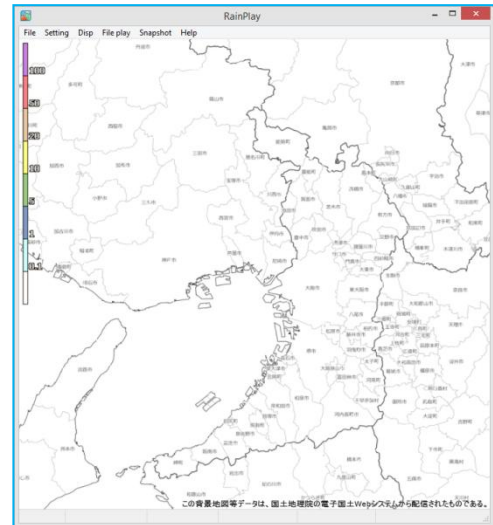
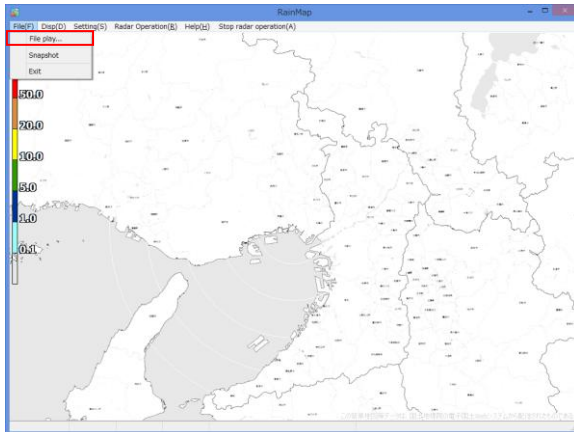
Stop motor of radar and TX at once.



## 8.7. RainPlay operation

RainPlay will indicate after selecting [File play] on RainMap.

It could also possible to use RainPlay.exe from “RainMap\_RainPlay” folder on desktop even during RainMap is activating.



### File

#### File play:

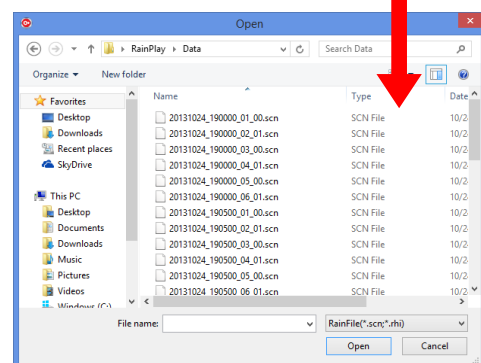
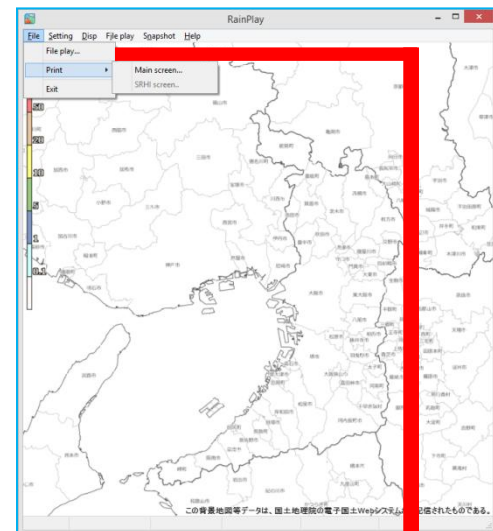
Select files of log data (\*.scn; \*rhi, sppi scnd, rhid, sppid) to play (Slide show) on screen

#### Print:

- Main screen: Printout the main screen
- SRHI screen: Printout the SRHI screen

#### Exit:

To close a software



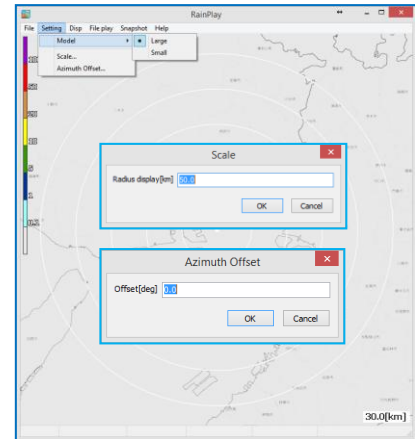
## Setting

### Scale:

Setup a distance of scale into a pop-up window of [Scale]

### Azimuth offset:

Setup a degree of offset into a pop-up window of [Azimuth Offset]

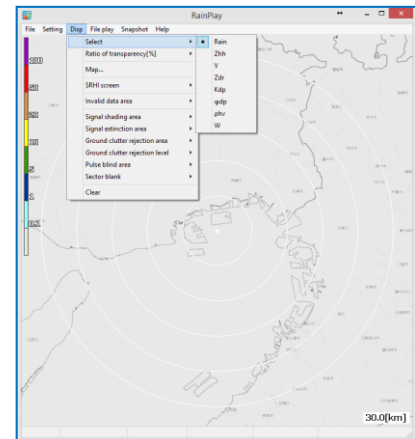


## Disp

### Select:

Select an indication of data type:

- **Rain**: Intensity of rainfall
- **Zhh**: Reflection factor of the horizontal polarimetric radar
- **V**: Doppler velocity
- **Zdr**: Radar reflection factor difference
- **Kdp**: Propagation phase difference rate of change
- **Φdp**: Differential Phase Shift
- **ρhv**: Polarimetric Correlation Coefficient
- **W**: Spectral Width



**Notice, the following data types are disused:** Zdr, Kdp, Φdp, ρhv

### Ratio of transparency [%]:

Setup a Transmittance of the indication echo.

### Map:

Output a map from input file (\*.bmp)

### SRHI screen:

- 90 deg screen (Indicate the echo of SRHI with 90 degrees)
- 180 deg screen (Indicate the echo SRHI with 180 degrees)

### Invalid data area:

Turn ON/OFF the indication of invalid data area.

### Signal shading area:

Select the indication of signal shading area.  
OFF: Hidden, 1: Grayed out, 2: Gray scale

### Signal extinction area:

Select the indication of signal extinction area beyond strong rain area.  
OFF: Hidden, 1: Grayed out, 2: Gray scale

### Ground clutter rejection area:

Select the indication of ground clutter rejection area.

OFF: Hidden, 1: Grayed out, 2: Gray scale

### Ground clutter rejection level:

Select the level of ground clutter rejection from 0 to 7

### Pulse blind area:

Select the indication of pulse blind area.

OFF: Hidden, 1: Grayed out, 2: Gray scale

### Sector blank:

Select the indication of sector blank.

OFF: Hidden, 1: Grayed out, 2: Gray scale

### Clear:

Data of Rain file will be cleared from screen

**Play****Start:**

Start playing a log data

**Stop:**

Stop playing

**Pause:**

Pause playing

**Fast Forward:**

Fast forward playing

**Rewind:**

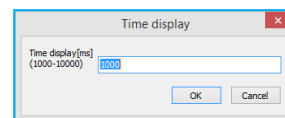
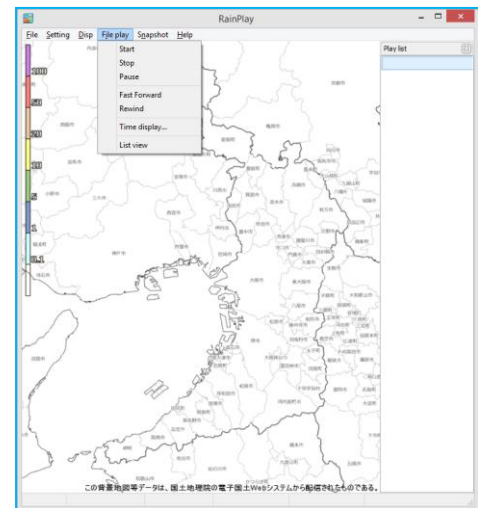
Rewind playing

**Time display:**

Popup a setup windows Setup a time display [between 1000 - 10,000 ms]

**List view:**

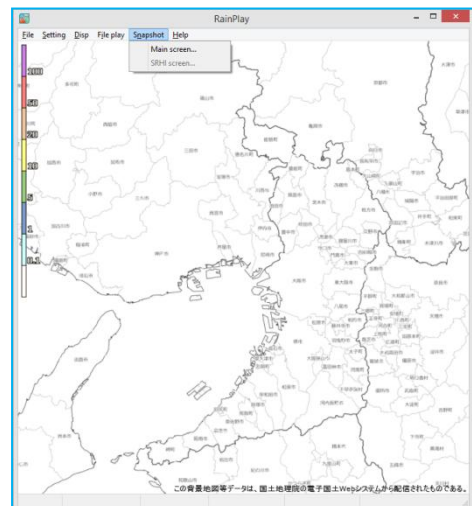
To show a play list on the right screen

**Snapshot****Main screen:**

Copy a main screen and select a place to save a screen file(\*.jpg)

**SRHI screen:**

Copy a SRHI screen and select a place to save a screen file(\*.jpg) while  
Indicating SRHI screen from [Disp]





## 8.8. Initial setting of Azimuth

The real geographical feature and azimuth are different with the initial echo indication, therefore it has to make an adjustment.

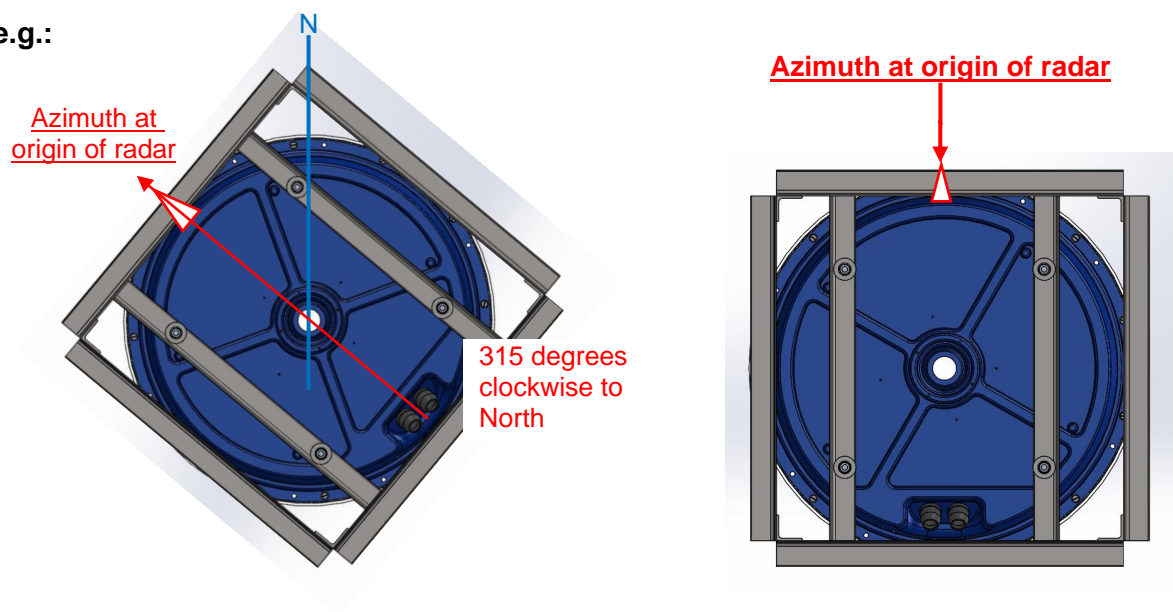
At first, it has to setup "Azimuth Offset" in RainMap software by measuring the azimuth at origin. It generally uses a magnetic compass, GPS compass, or the solar measure tool.

The unit of resolution is 0.01 degree on a value of measurement.

Measurement range: (+) 0 to 359 degrees.

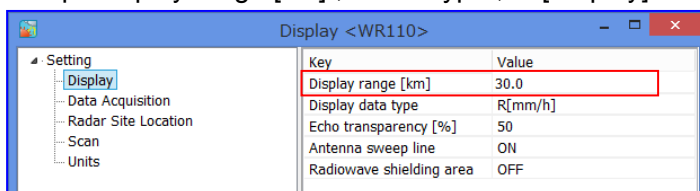
e.g.: 45 degrees (measurement value) = 315 degrees (value of measurement equipment)

e.g.:

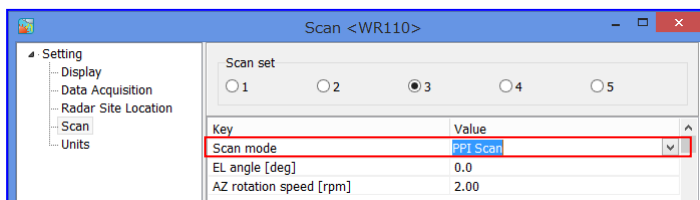


Notice: Ground clutter rejection must be "OFF" during this operation.

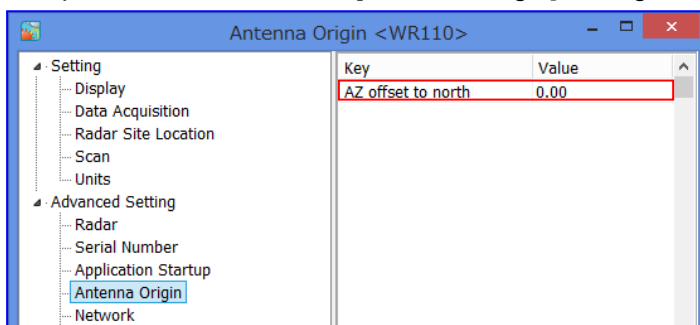
- 1) Use a map of geographical features around the place installed the radar unit. (e.g. Google map)
- 2) Setup "Display range [km]", "Data Type", in [Display] setting menu of RainMap.



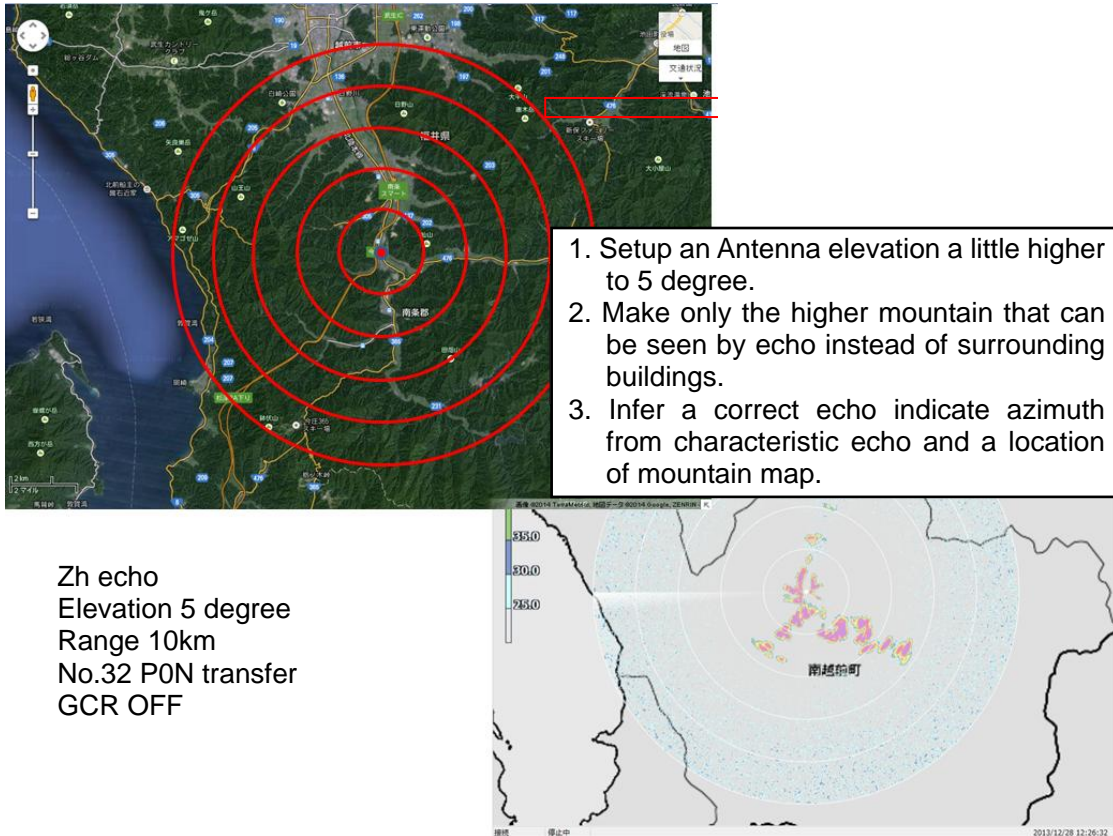
- 3) Setup "PPI elevation" in [Scan] setting menu of RainMap.



- 4) Setup "AZ offset to north" in [Antenna Origin] setting menu of RainMap.



<Image screen>

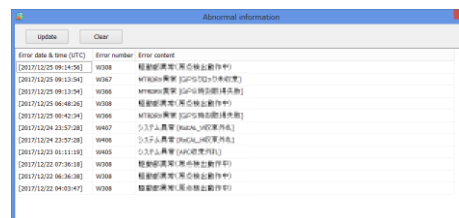


- 5) Click [STBY] from [Radar operation] to Stop TRX.
- 6) Indicate a map and RainMap on a screen (or use other PC to see a map).
- 7) Grasp a characteristic geographical feature (check some top of the mountains' line form, distance, and relative bearing) from map.
- 8) Transfer the wavelength to a higher direction for not to receive an echo from lower building or structure after setting elevation to 5 degrees (It could be 3 to 7 degrees in some case) in RainMap.
- 9) Setup a distance that could be easier to confirm a geographical feature of "3)" to "Range [km]" in [View] setting menu of RainMap.
- 10) Setup "Reflective Intensity [H]" at "DataType" in [View] setting menu of RainMap.
- 11) Confirm an echo after starting [TX] from [Radar operation]. Purple part means a strong echo that might be came from a mountain.
- 12) Click [STBY] from [Radar operation] before make any change for setting. Then, to change an angle of "Azimuth Offset" in [RDR Parameter] service menu of RainMap by comparing a shape of echo with "3)" and "7)". Echo indication will be rotated to clockwise if entered a large value at "Azimuth Offset". (Available range: -360 to 360)
- 13) Repeat a step "7)" to "8)" until an echo accords with a geographic feature
- 14) Click [STBY] from [Radar operation] after finished "9)".
- 15) Set 0 degree at [Elevation] in [View] setting menu of RainMap.
- 16) Set a distance that suitable for the field at "Range [km]" in [View] setting menu of RainMap.
- 17) Select "Rainfall Intensity" at [DataType] in [View] setting menu of RainMap.
- 18) Finish a setting

## 8.9. Log file function

### 1) Abnormal information

It indicates error information up to 50 on the screen. It will overwrite when it goes over 50 and those logs will save into log file (in the same folder of RainMap.exe).



### 2) Log record:

Log record folder will be created automatically in to RainMap folder and to save log data [log]

- RainMap.log (Log file)

- YYYYMMDDhhmmss.dat (The configuration file which compressed (ZIP) the transmission start date and time is up to 1, 000 files)

### 3) Limit of Log file (RainMap.log):

When a file of transmission start date and time is over 1,000 files, it will overwrite from the oldest file.

### 4) Log file (RainMap.log) format:

Use Text format to save it.

e.g.)

[2014/06/17 10:35:06] SendParam,20140617\_103506.dat

[2014/06/18 20:08:45] TRxStart,20140618\_200845.dat

Configurations file (YYYYMMDDhhmmss.ini)

This file is saved by section and key setting with RainMap software.

(This file saves the current setup information that setting in the RainMap)

RainMap\_ErrorDisp.log: It saves the display detail of failure information that refers from GUI of RainMap.

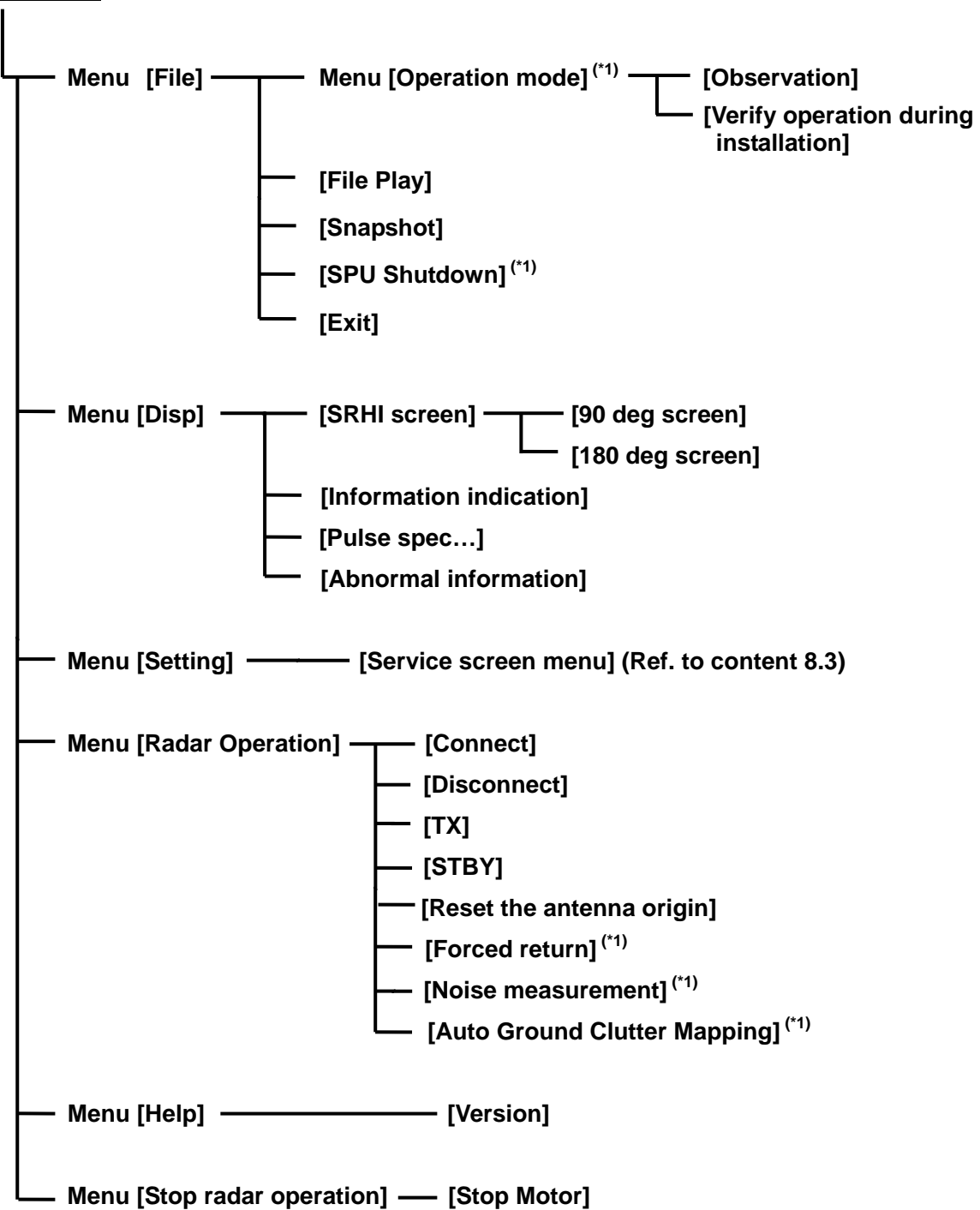
RainMap\_ErroHist.log: It saves all failure that occurred before.

Detail of Log record contents: (It records a normal and error situation)

Message	Detail	Situation	Remarks
AppStart	—	Start of Application	
AppEnd	—	End of Application	
Connect	—	Start Connection	
Connected	Command	Connect Command Port	
	Data	Connect Data Port	
Disconnect	—	Shutdown Connection	
	Command	Shutdown Command Port	
	Data	Shutdown Data Port	
SendParam	(Saved configuration file)	Send Parameter	ZIP configuration file
TRxStart	(Saved configuration file)	Start TRX	ZIP configuration file
EmrStop	—	Emergency stop	
ErrStat	(PXI status)	Failure status	

## 9. Menu Tree

### RainMap



(\*1) : Click menu + press ([Ctrl] + [Alt]) key simultaneously.



## 10. Specification

### 10.1. Antenna Unit

Parameter	Descriptions	Remarks
Transmit Frequency	9.4 GHz band	
Occupied Band Width	40 MHz or less	
Maximum distance	70km	Displayable scale level: 0.5 to 70km
Doppler measurement	Max. $\pm 64$ m/sec	
Power supply	100 to 240VAC, Single Phase, 50/60 Hz	
Power consumption	Max. 250W	
Rated Ampere	1.5 to 3.5A	
Size	$\Phi 980$ mm $\times$ H1068mm	radome size
Weight	65kg (143.3lb)	
Operating Temperature	-10 to +50°C	
Storage Temperature	-40 to +70°C	
Water & Dust proof	IPX5	
Maximum wind survival	60m/sec	
Type of Emission	P0N(*1), Q0N(*2), V0N(*3)	
Peak Power	100 W	Horizontal
Duty Ratio	Up to 12 %	
Pulse Width	0.1 to 50 $\mu$ s	
Pulse Repetition Frequency	1600 to 2500 Hz	
Frequency Shift	2 to 20 MHz	except P0N
Antenna Type	Cassegrain	
Aperture Size	$\Phi 750$ mm	
Antenna Gain	33.0 dBi	
Antenna Polarity	Single polarimetric	Horizontal
Beam Width	2.7 degrees	Horizontal
AZ Rotation Speed	0.5 to 16 rpm	Adjustable
Horizontal Scan Angle	360 degrees	Continuously-rotating
Resolution of Angle	0.1 degrees	
Precision of Angle	0.2 degrees	

\*1 P0N : Sequence of pulses without modulation.

\*2 Q0N : Sequence of pulses, frequency modulation within each pulse.

\*3 V0N : Combination of P0N and Q0N.



## 10.2. Data Processing Unit

Receive data from Junction Unit (JCU) to indicate a picture of rainfall in real time.

Hardware	
Parameter	Descriptions
Power supply	100 to 240VAC, 50/60Hz
Power consumption	Max. 150W
Temp. range	0 to +50 °C
User Interface	
For weather observation system	
Software	RainMap, RainPlay
Data indication	Rainfall intensity R (mm/h), Reflectivity factor Zh (dBZ), Doppler velocity V (m/s), Doppler velocity spectrum width W (m/s),
Status display	Indicate ATU and DPU status
File output	Save and output one scan period data
For remote maintenance	
Software	TeamViewer GmbH
Version	TeamViewer Host (For remote server) 12
Function	Download the observation data and/or Setup an indicated software connecting by remote.
Requirement	It must be connecting to internet

### Notice of the data communication:

Condition of the data communication (Transfer efficiency: 50%)

Baud rate	Cycle (Data transmission possibilities)
1Mbps/min or more	4 elevations/ 5min.
4Mbps/min or more	2 elevations/ 1min.
8Mbps/min or more	4 elevations / 1min.

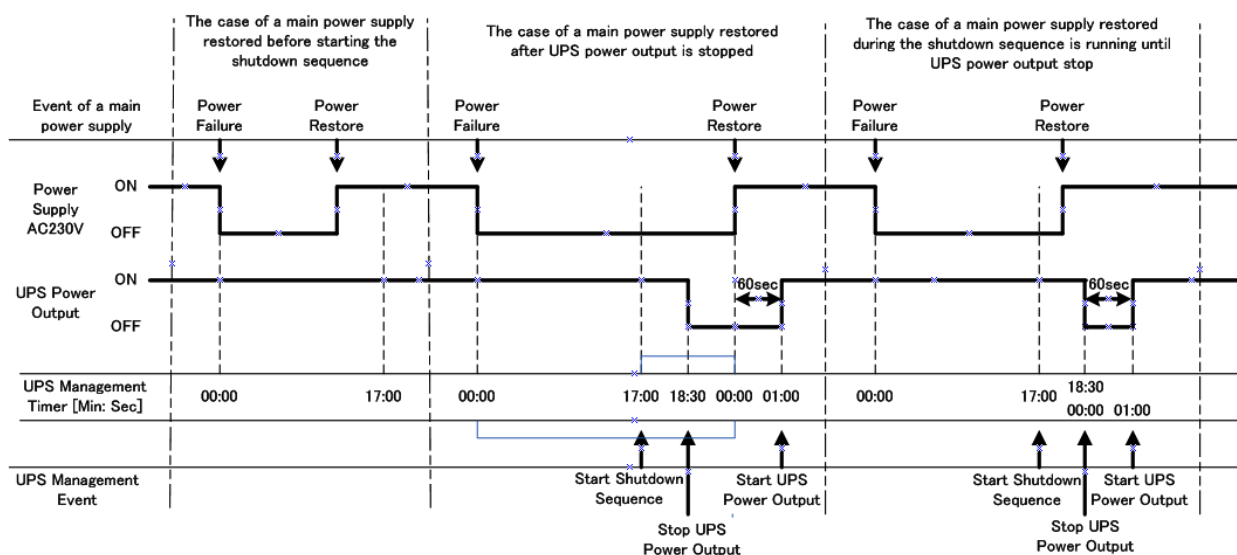
## 11. UPS settings

### 11.1. APC product

This procedure is only for Smart-UPS 1500RM model, it picked up only for some main points Setup on software of "Power Chute".

General	Power Parameters	High Transfer [V]	265	
		Low Transfer [V]	196	
		Sensitivity	High	
		Nominal Output [V]	220	
		Audible Warning	On Battery	
Server Shutdown	Shutdown Sequence	Command File	Not Enabled	
		Operating System	Delay [mins]	00:00
			Duration [mins]	01:30
	Power Failure	When power fails, begin a shutdown procedure	At runtime limit	
		When power returns, reboot UPS	After the following occurs	Battery charges to 0% And the elapsed time is: 60sec
	Shutdown Type	Shutdown		

Note: For the rest of the above setting would be default setting.



※ UPS runtime limit (e.g. 17minutes)

### 11.1.1. Login

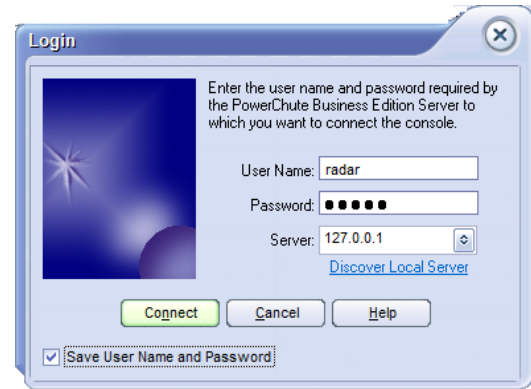
Power Chute would be popup after start DPU.

User Name: radar

Password: radar

Server: 127.0.0.1

Click [Connect] to login.



### 11.1.2. Power Protection Strategy

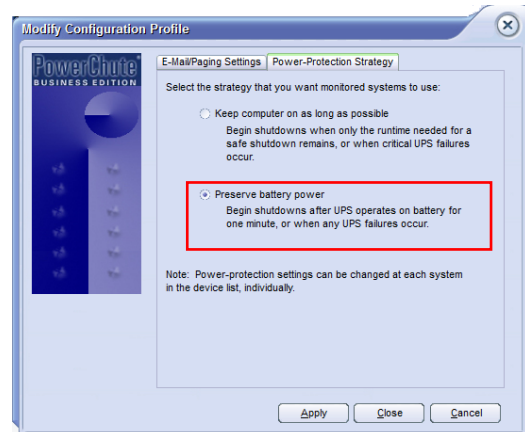
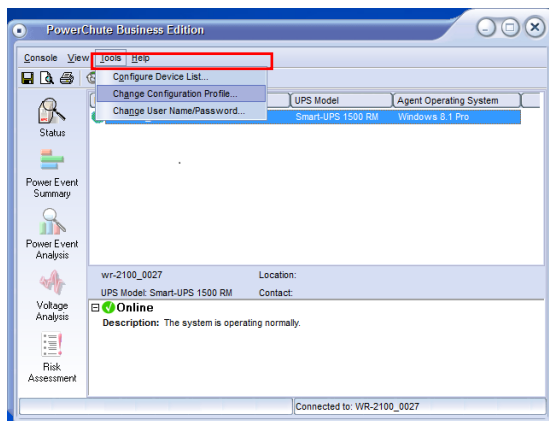
#### Preserve Battery Power:

1) Open configuration profile:

[Tools] -> [Change Configuration Profile]

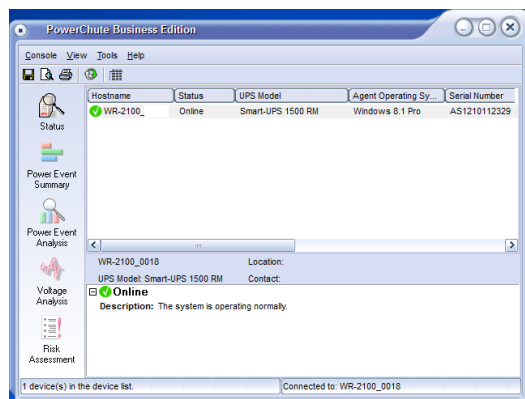
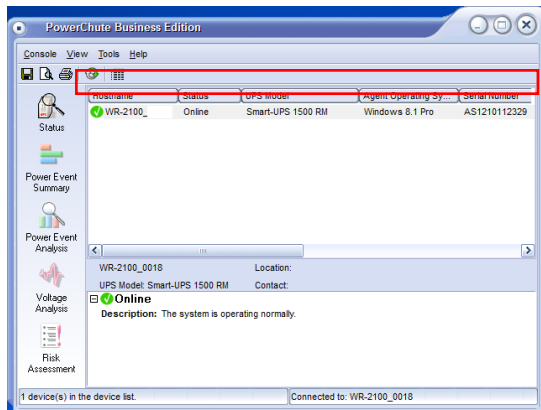
2) Click [Power-Protection Strategy] tab:

Put a check on [Preserve battery power]

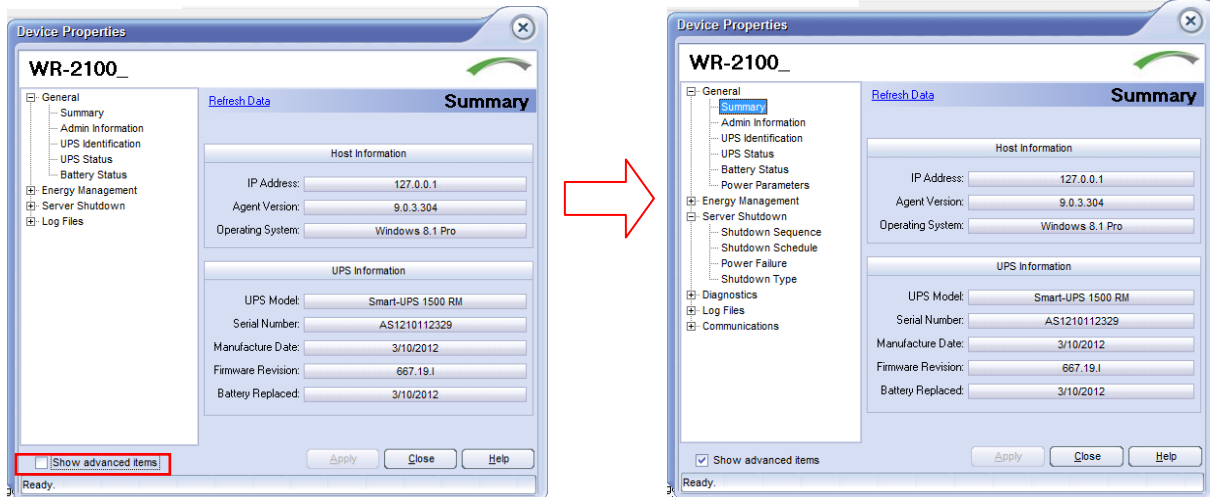


#### Power Parameter:

1) Right click at [WR110\_xxxx] to open device property.

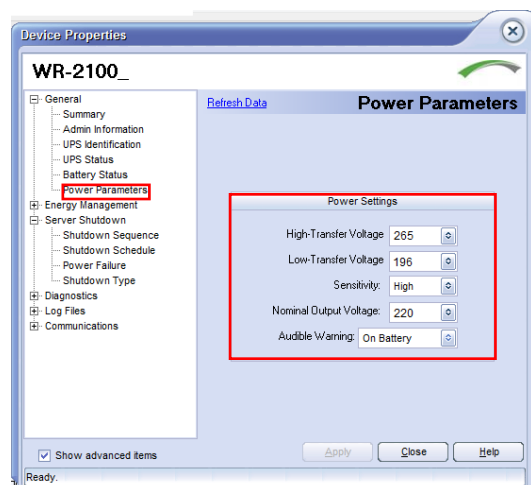


2) Put a check on [Show advanced items] to indicate more items trees.



3) Click [Power Parameter] Setup the power settings:

High-Transfer Voltage: 265  
 Low-Transfer Voltage: 196  
 Sensitivity: High  
 Nominal Output Voltage: 220  
 Audible Warning: On Battery

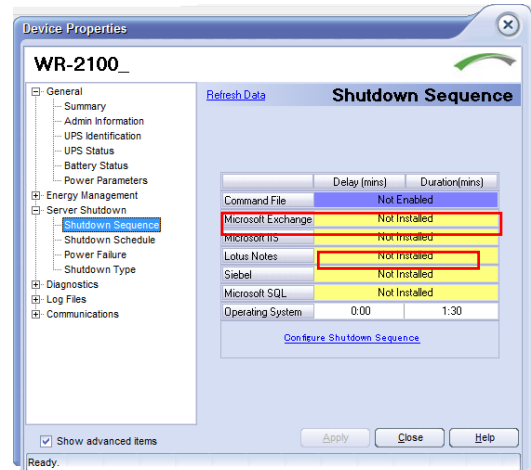


### Shutdown Sequence

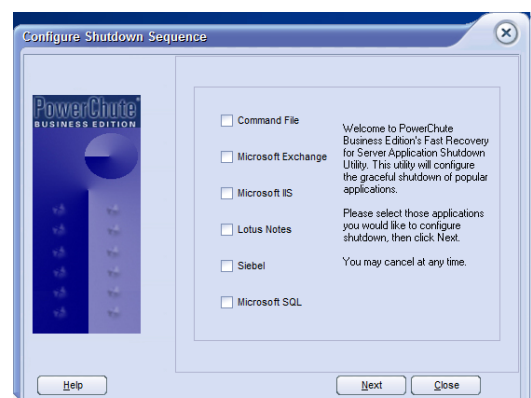
1) Click [Server Shutdown] -> [Shutdown Sequence]  
 Setup the shutdown sequence:

Command File: Not Enabled Operating System:  
 - Delay [mins]: 0:00  
 - Duration [mins]: 1:30

Click [Apply] if anything changed.



2) Click "[Configure Shutdown Sequence](#)"  
 3) Without checking to any items, click [Next]

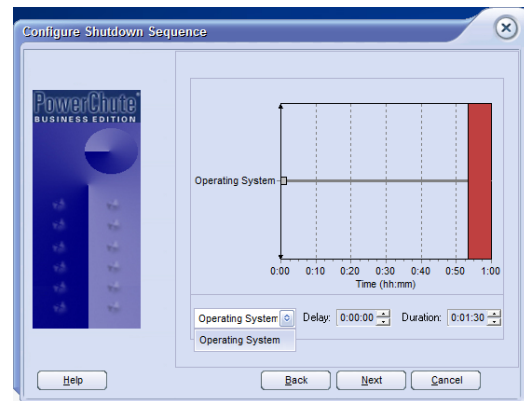


## 4) Setup [Operating System] as follows:

- Delay: 0:00:00
- Duration: 0:01:30

## 5) Click [Next] to save it

## 6) Click [Finish] to close shutdown sequence

**Power Failure**

## 1) Click [Server Shutdown] -&gt; [Power Failure] Setup as follows:

When power fails, begin a shutdown procedure:

At runtime limit

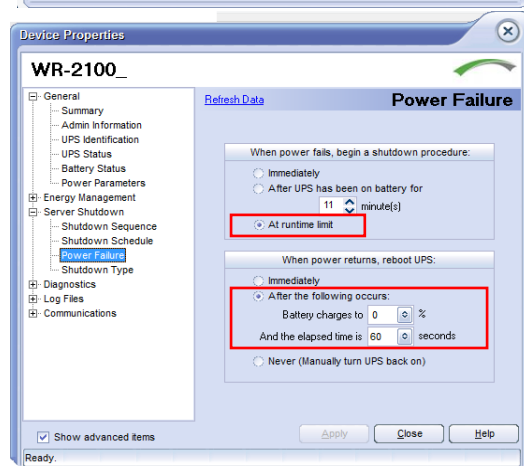
When power returns, reboot UPS:

Put a check and enter a percentage & time on [After the following occurs:]

Battery charges to 0 %

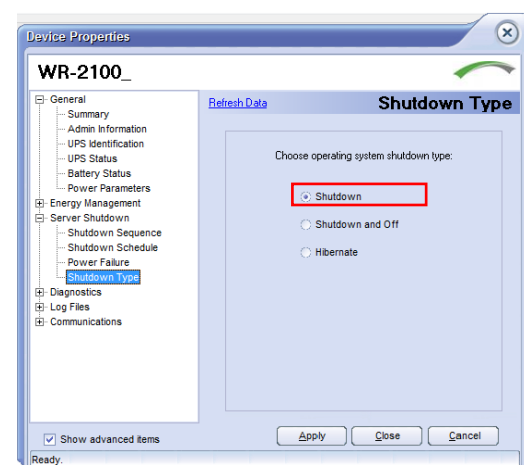
And the elapsed time is 60 seconds

## 2) Click [Apply] to save it

**Confirm Shutdown Type**

## 1) Click [Server Shutdown] -&gt; [Shutdown Type] Put a check on: Shutdown

## 2) Click [Apply] -&gt; [Close]



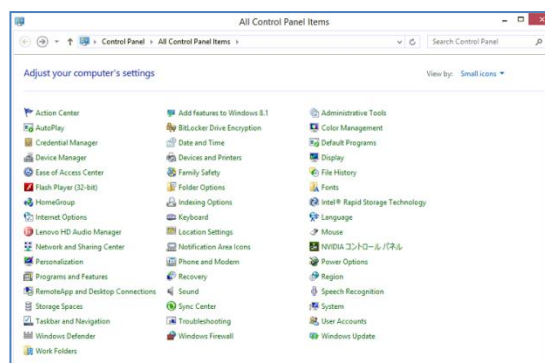
## 12. Windows Language setting

Notice: The DPU display language must set to Japanese to upgrade the FWR software. the program will be upgraded in the near future so that the language change to Japanese is no longer necessary.

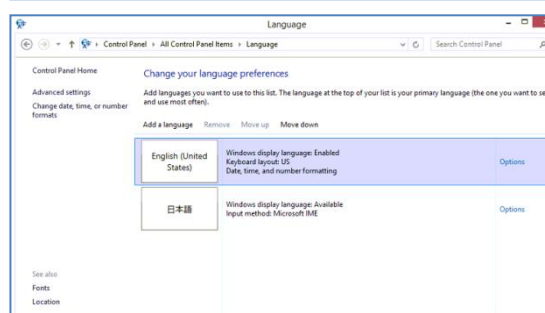
The DPU must be able to change display language from English to Japanese.

RainMap and Power Chute (UPS software) menus and indications automatically change language.

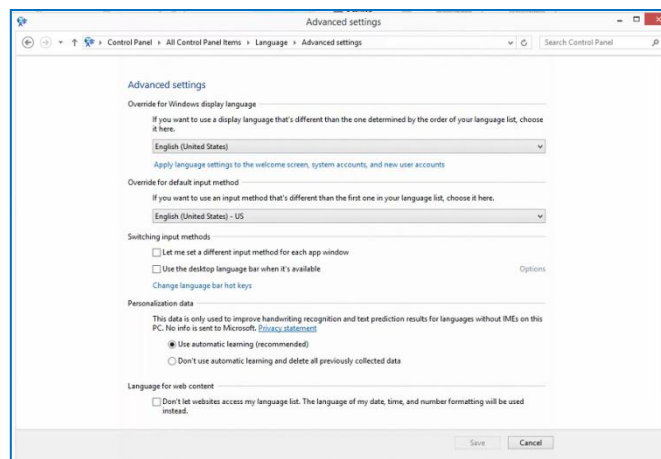
1. Click [Control Panel] from [Startup] button (Left bottom of Windows screen).
2. Click [Language].



3. Choose a language and double click. Add a language if your language is not in the list.

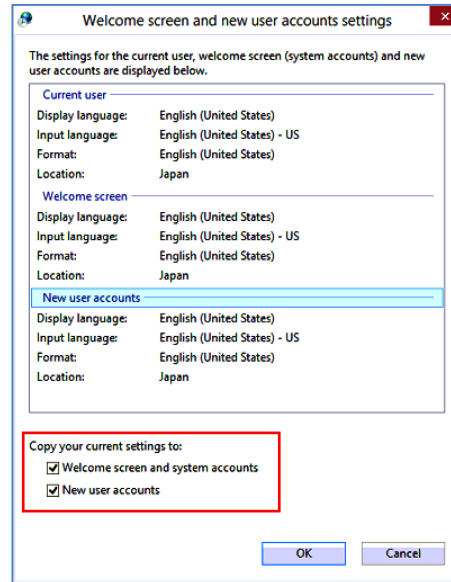
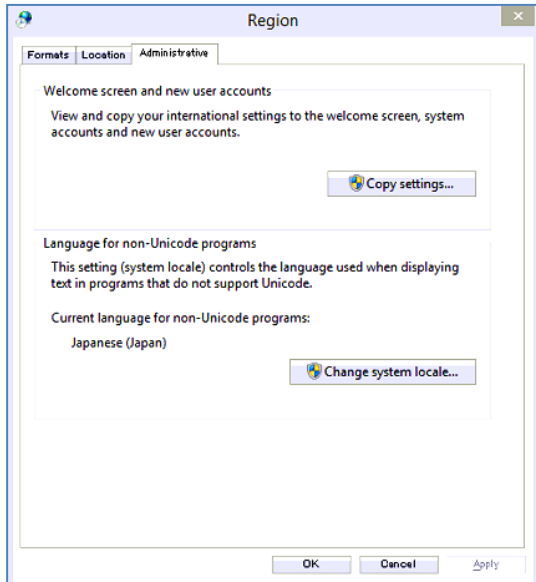


4. Open [Advanced settings] Select the language at [Override for windows display language] and [Override for default input method].

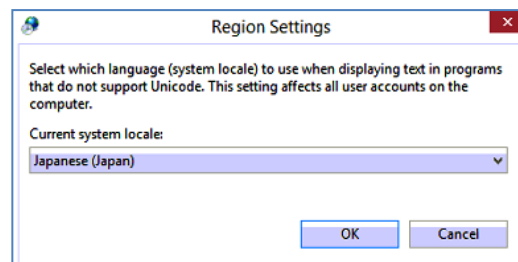
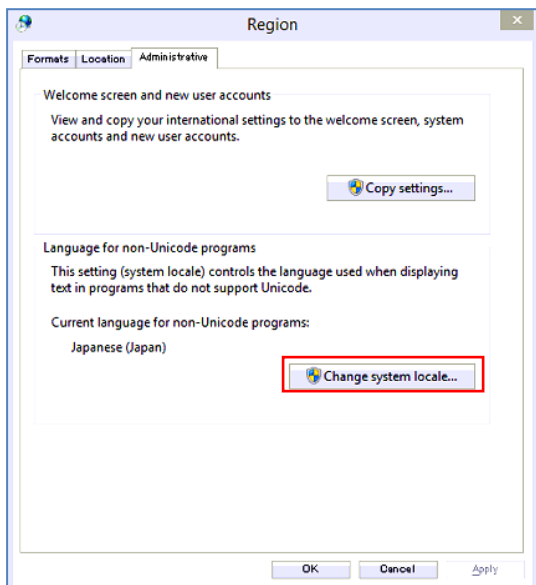


## 5. Setup [Region]

- Click the [Administrative] tab.
- Click the [Copy settings...] button in the [Administrative] tab to show the [Welcome screen and new user accounts settings].
- Put a check on “Welcome screen and system accounts”, and “New user accounts” at “Copy your current settings to:”.
- Click [OK] to exit [Welcome screen and new user accounts settings].



- Click [Change system locale...] button in [Administrative] tab to popup [Region Settings].
- Choose a language of “Current system locale”.
- Click [OK] to exit [Region Settings].



- Click [OK] to exit [Region].
- Reboot PC to reflect your language settings.