

- Remove the cable clamp, then remove the cable.

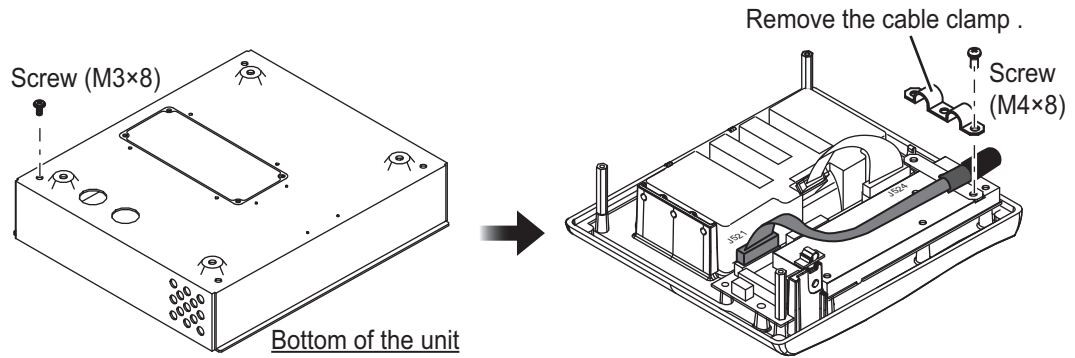

- Pass the cable through the hole in the figure shown in the figure to the right, then clamp the copper part of the cable with the cable clamp removed at step 1.

**Note:** If the RCU-016 is connected in series with RCU-015, connect J522 instead of J521.

- Close the back cover of RCU-016.

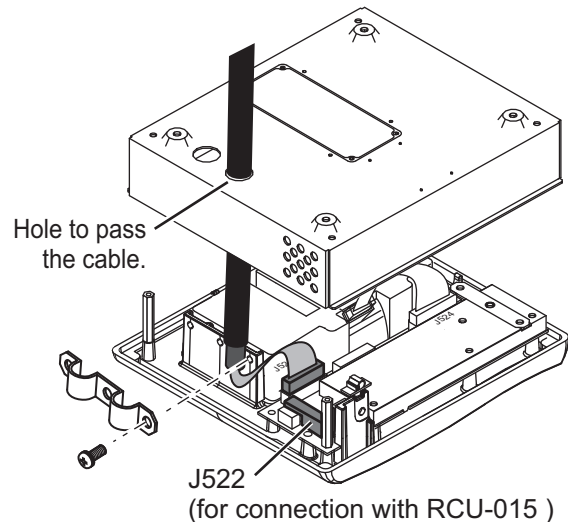

## 1.5 Power Supply Unit

This unit can be installed on a bulkhead, wall or on the floor.

### 1.5.1 Installation considerations

Keep in mind the following points when selecting a location.

- Locate the Processor Unit away from heat sources because of heat that can build up inside the cabinet.
- Select a location where the vibration is minimal.
- Locate the equipment away from places subject to water splash and rain.
- Leave sufficient space at the sides and rear of the unit to facilitate maintenance.
- A magnetic compass will be affected if the Processor Unit is placed too close to the magnetic compass. Observe the compass safe distances in the SAFETY INSTRUCTIONS to prevent interference to a magnetic compass.

## 1. INSTALLATION

- Install the Processor Unit on the floor, or on a bulkhead referring to the following directions. For bulkhead, the cable entry must face the deck.

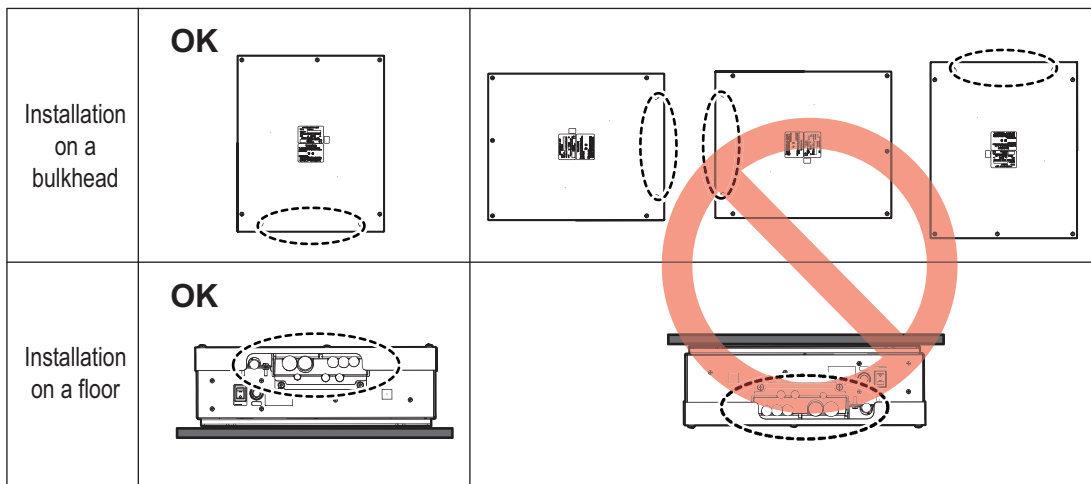

 : Cable entry

- Connect the ground wire (IV-8sq, local supply) between the earth terminal on the chassis and the ship's earth, using the supplied crimp-on-lug FV2-4 BLU.

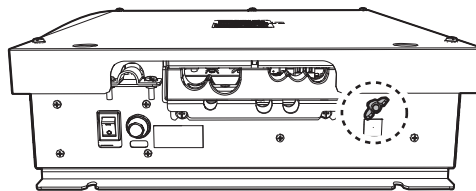

### 1.5.2 How to install the Power Supply Unit

Use four bolts (M6, local supply) to fasten the Power Supply Unit.

For bulkhead mounting, fasten two bolts for the lower notches, leaving 5 mm of thread exposed from the bolt head. Set the notches of the Power Supply Unit on the two bolts, then fasten two bolts for the upper bolt holes. Then secure the Power Supply Unit in place with all four bolts fastened tightly.

**Note:** For bulkhead installations, the cable entry must face the deck.

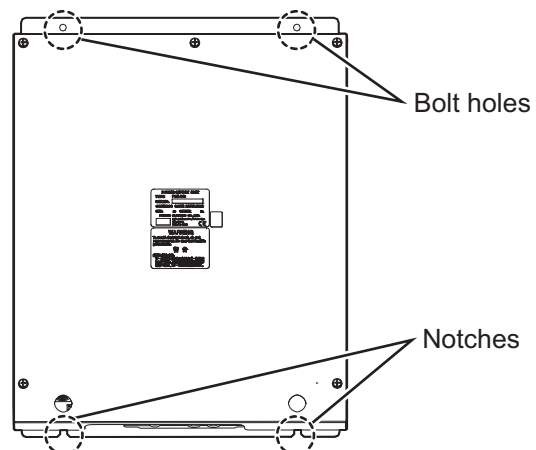

## 1.6 Processor Unit

This unit can be installed on a bulkhead, wall or on the floor.

### 1.6.1 Installation considerations

Keep in mind the following points when selecting a location.

- Locate the Processor Unit away from heat sources because of heat that can build up inside the cabinet.
- Select a location where the vibration is minimal.
- Locate the equipment away from places subject to water splash and rain.
- Leave sufficient space at the sides and rear of the unit to facilitate maintenance.
- A magnetic compass will be affected if the Processor Unit is placed too close to the magnetic compass. Observe the compass safe distances in the SAFETY INSTRUCTIONS to prevent interference to a magnetic compass.
- Allow for a service clearance of 100 mm in front of the vent hole (front and rear sides).

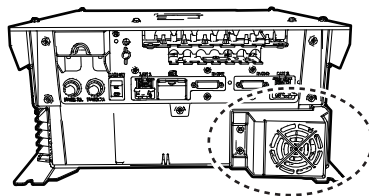

Front view  
(Cable entrance side)

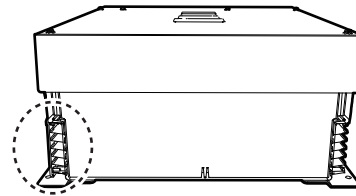

Rear view

○ : Vent hole

- Install the Processor Unit on the floor, or on a bulkhead with the following direction. For bulkhead, the cable entry must face the deck.

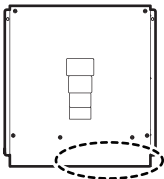
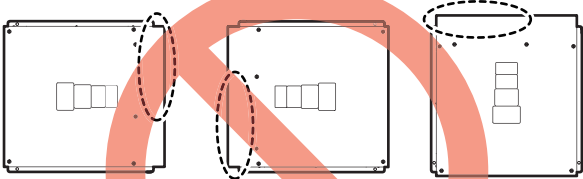
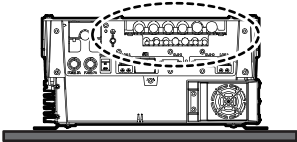
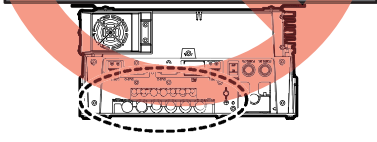
<p>Installation on a bulkhead</p>	<p><b>OK</b></p> 	
<p>Installation on a floor</p>	<p><b>OK</b></p> 	

○ : Cable entry

## 1. INSTALLATION

- Connect the ground wire (IV-8sq, local supply) between the earth terminal on the chassis and the ship's earth, using the supplied crimp-on-lug FV2-M3 BLU.

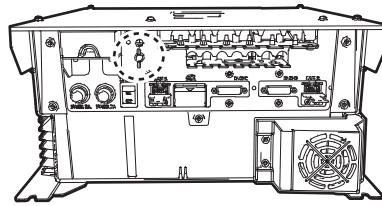

### 1.6.2 How to install the Processor Unit

Use four bolts (M6, local supply) to fasten the Processor Unit.

For bulkhead mounting, fasten two bolts for the lower notches, leaving 5 mm of thread exposed from the bolt head. Set the notches of the Processor Unit on the two bolts, then fasten two bolts for the upper bolt holes. Then secure the Processor Unit in place with all four bolts fastened tightly.

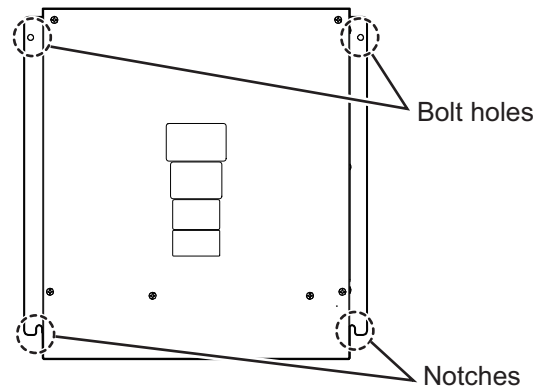

**Note:** For bulkhead installations, the cable entry must face the deck.

## 1.7 Transceiver Unit

The transceiver unit is required for TR-DOWN Radar.

### Installation considerations

Keep in mind the following points when selecting a location.

- Locate the unit away from heat sources because of heat that can build up inside the cabinet.
- Locate the equipment away from places subject to water splash and rain.
- Leave sufficient space at the sides and rear of the unit to facilitate maintenance.
- Determine the location considering the length of the cable between the transceiver unit and the Antenna Unit and the cable between the transceiver unit and the Power Supply Unit.
- A magnetic compass will be affected if the transceiver unit is placed too close to the magnetic compass. Observe the compass safe distances in the SAFETY INSTRUCTIONS to prevent interference to the compass.
- Be sure to connect the ground wire (between the earth terminal on the chassis and the ship's earth).

### How to mount the transceiver unit

Fix the unit to the mounting location with M6 bolts or  $\phi 6$  coach screws. See the outline drawing for mounting dimensions.

## 1.8 Intelligent Hub (option)

Use the optional Intelligent Hub HUB-3000 to connect gateway network equipment. Do not connect this network to the shipborne LAN network. Further, do not connect a PC to this network, other than for maintenance.

### Installation considerations

Keep in mind the following considerations when selecting a location.

- Locate the hub away from heat sources because of heat that can build up inside the cabinet.
- Select a location where the vibration is minimal.
- Locate the hub away from places subject to water splash and rain.
- Be sure to connect a ground (between the earth terminal on the hub and the ship's earth).
- Leave sufficient space at the sides and rear of the unit to facilitate maintenance.
- A magnetic compass will be affected if the hub is placed too close to the magnetic compass. Observe the compass safe distances in the SAFETY INSTRUCTIONS to prevent interference to a magnetic compass.

### How to install the Intelligent Hub

1. Use two binding screws (M3×6, supplied) to attach the cable clamp (supplied) to the bottom of the HUB-3000.

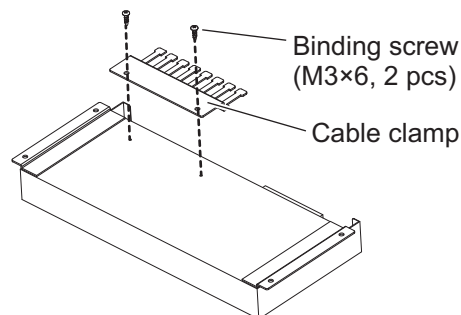

*Bottom view*

2. Fasten four self-tapping screws ( $\phi 4 \times 20$ , supplied) to secure the unit.

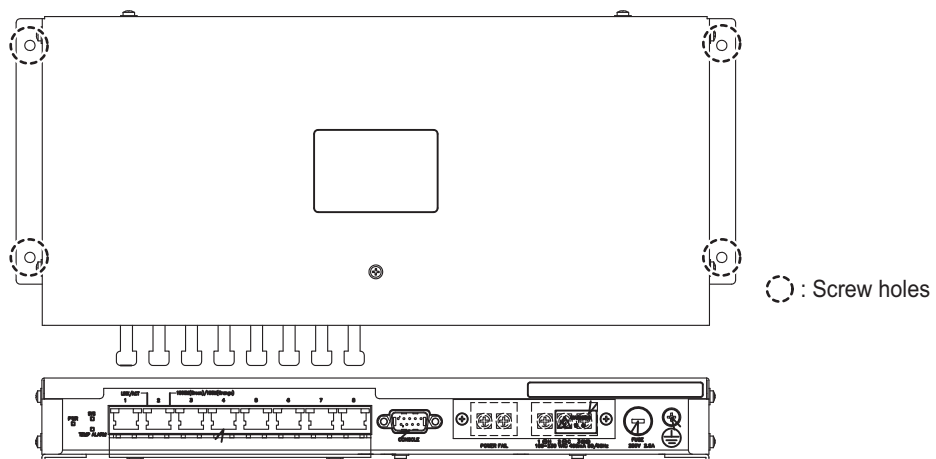

## 1.9 Switching Hub (option)

Use the HUB-100 to connect sensor networks. This network cannot be connected to the shipborne LAN network. Further do not connect a commercial PC to this network, other than for the maintenance.

For the installation procedure, see the operator's manual for HUB-100 (Pub. No. OMC-35191).

### **Installation considerations**

Keep in mind the following points when selecting a location.

- Locate the hub away from heat sources because of heat that can build up inside the cabinet.
- Select a location where the vibration is minimal.
- Locate the equipment away from places subject to water splash and rain.
- Make sure that the ground wire is connected between the earth terminal on the hub and the ship's earth.
- Leave sufficient space at the sides and rear of the unit to facilitate maintenance.
- A magnetic compass will be affected if the hub is placed too close to the compass. Observe the compass safe distances in the SAFETY INSTRUCTIONS to prevent compass malfunction.

## 1.10 Junction Box (option)

If the length of the antenna cable is more than 100 m, junction boxes are required. Install the boxes in a location protected from the weather, because their waterproofing standard is IPX3.

Fasten the junction boxes to the mounting location with four sets of M8 bolts and nuts. See the outline drawing for mounting dimensions.

# 2. WIRING

---

## 2.1 Overview

### Cable considerations

To lessen the chance of picking up electrical interference where possible, avoid routing the antenna cable (power and LAN lines) near other onboard electrical equipment (radars, TX radio antennas, etc.). Also avoid running the cable in parallel with power cables. When crossing with other cable, the angle must be 90° to minimize the magnetic field coupling.

The antenna cable between the antenna and Processor Units is available in lengths of 15 m, 30 m, 40 m, and 50 m. Whatever length is used, it must be unbroken; namely, no splicing allowed. Use the antenna cable as short as possible to minimize attenuation of the signal.

The radar must be connected to an emergency power source, as required by SOLAS II-1.

### About wiring

- The length of LAN cables must be within 50 m.
- Use Cat5e or Cat6 LAN cable for the network if available locally.
- If LAN cables are not available locally, use the optional LAN cables (FR-FTPC-CY for sensor network, DTI-C5E350 VCV for gateway network).
- If extension or division of the DVI or RGB cables is necessary, use the dividers shown below.
  - DVI cable divider: DVI-12A (maker: IMAGENICS)
  - RGB divider: CIF-12H, DD-106 or WBD-14F (maker: IMAGENICS)
- Make sure that the ground wires are connected between the ground terminals on each equipment and the ship's earth.
- Pass the cables through the specified clamp or the locking wire saddle.
- If a UPS (user supply) is connected to this equipment, be sure that the grounding lamp does not light.
- The output from the UPS must be a sine wave, as shown in the figure to the right.

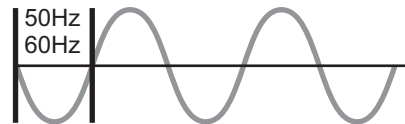

### About network construction

- Use the optional Switching Hub HUB-100 to connect the sensor networks. For the gateway networks, use the optional Intelligent Hub HUB-3000.
- Do not connect the ship's LAN network to the optional HUBs. Also, commercial PCs cannot be connected to the gateway network, other than for maintenance.
- To connect the FAR-2xx7 series via LAN network, use the Gateway network.
- This unit does not support IGMP snooping or CGMP enabled switch.
- This unit does not have a router or repeater hub function.
- The Switching HUB HUB-100 does not support IGMP snooping or GCMP enabled switch.

## 2. WIRING

### 2.1.1 Standard wiring

A Cat 5e LAN cable (RW-00135, RW-00339) connects between the Antenna Unit (Power Supply Unit for FAR-2258/2268DS) and the Processor Unit. The maximum length of the cabling between the Processor Unit and the Antenna Unit is 80 m.

Retrofit (using antenna cable RW-9600/4896) or foremast installation is also possible, with the installation of a pair of LAN Signal Converters, one in the Antenna Unit, the other in the Processor Unit. See section 2.10.

#### **X-band/S-band (TR-UP) radars for FAR2x18/2x28/2x38 radars**

The appropriate radars are FAR-22x8(-BB), FAR-2228-NXT(-BB), FAR-23x8, FAR-2328-NXT, FAR-22x8S(-BB), FAR-23x8S(-NXT) and FAR-2238S-NXT(-BB).

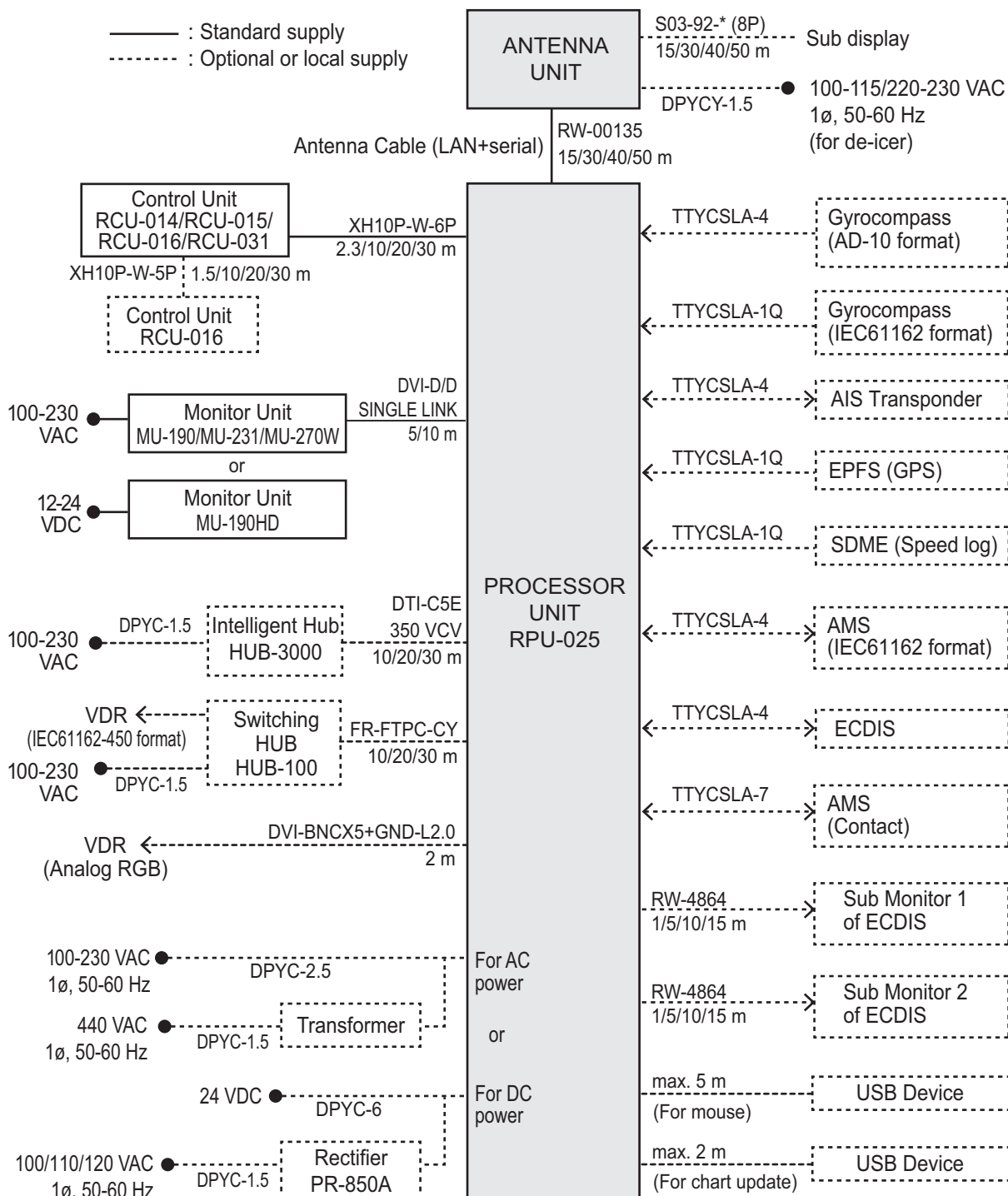



**X/S-band radars for FAR-2258/2268DS radars**

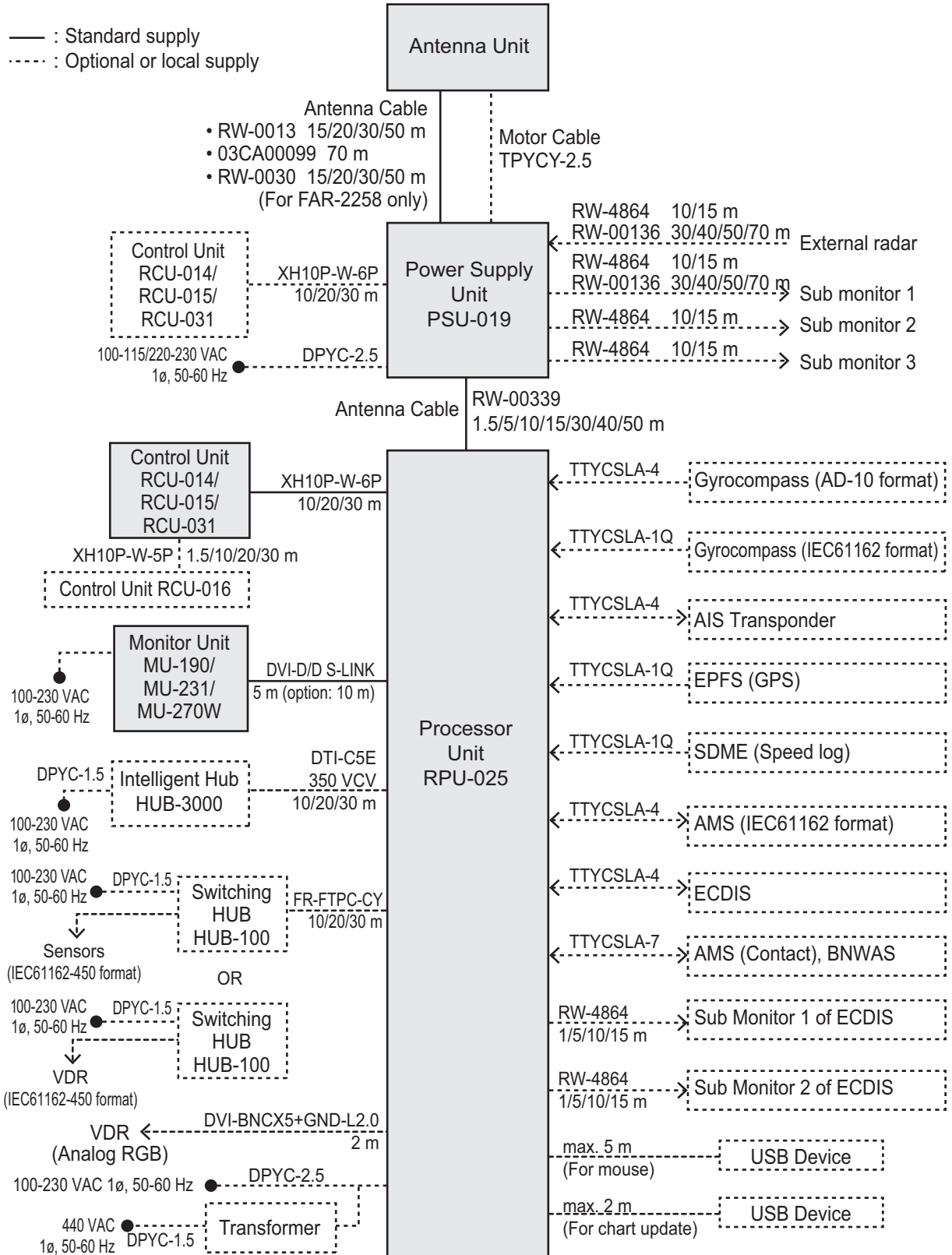

## 2. WIRING

### X-band/S-band (TR-DOWN) radars

The appropriate radars are FAR-2328W and FAR-2338SW.

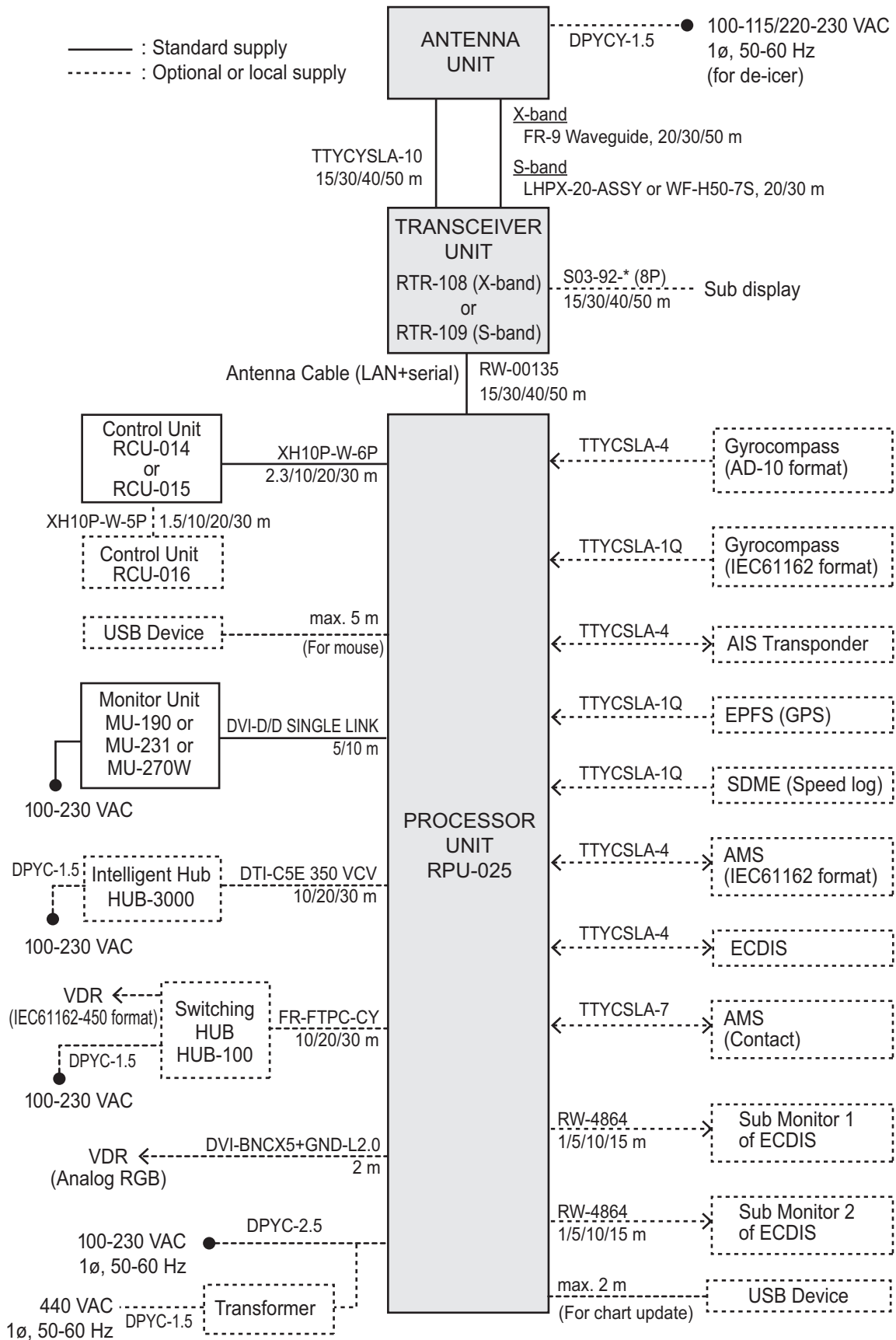

**WAGO connector**

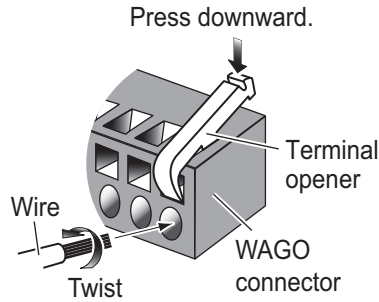

**Procedure**

1. Twist the cores.
2. Press the terminal opener downward.
3. Insert the wire to hole.
4. Remove the terminal opener.
5. Pull the wire to confirm that it is secure.

A terminal opener is provided on the circuit board as below.

- FAR-2x18/2x28/2x38 radars

**Processor Unit**

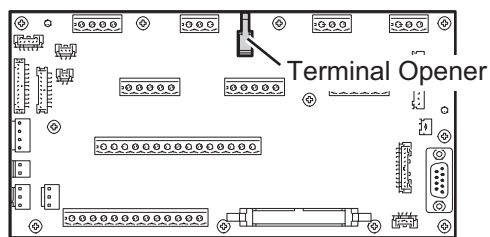

TB Board 03P9648

**Antenna Unit/Transceiver Unit**

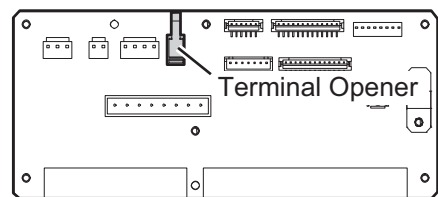

RF-TB Board 03P9570

- FAR-2258/2268DS radars

**Power Supply Unit**

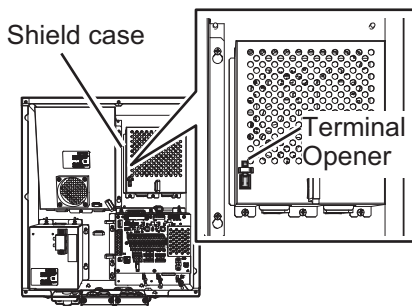

**Antenna Unit**

<FAR-2258>

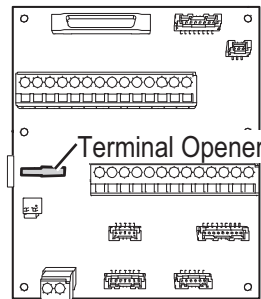

RF-TB Board 03P9665

<FAR-2268DS>

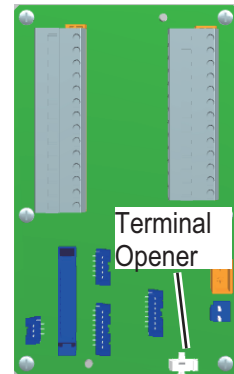

RF-TB Board 03P9712

## 2.2 Antenna Unit for X-band, TR-UP Radar

### 2.2.1 How to fabricate the cables

#### LAN cable



Expose inner vinyl sheath.

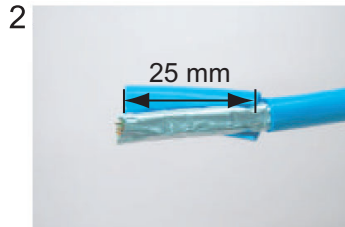

Remove the inner vinyl sheath by approx. 25 mm. Be careful not to damage inner shield and cores.

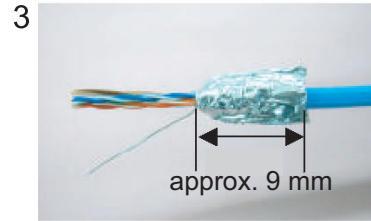

Fold back the shield, wrap it onto the inner vinyl sheath and cut it, leaving approx. 9 mm.

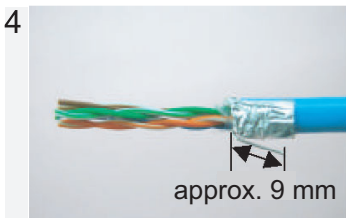

Fold back drain wire and cut it, leaving approx. 9 mm.

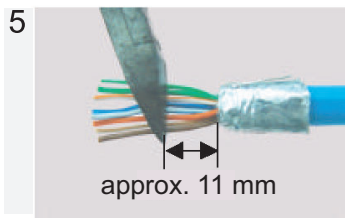

Straighten and flatten the cores in colored order and cut them, leaving approx. 11 mm.

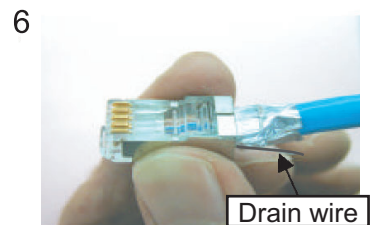

Insert the cable into the modular plug so that the folded part of the shield enters into the plug housing. The drain wire should be located on the tab side of the jack.



Using special crimping tool MPT5-8AS (PANDUIT CORP.), crimp the modular plug. Finally, check the plug visually.

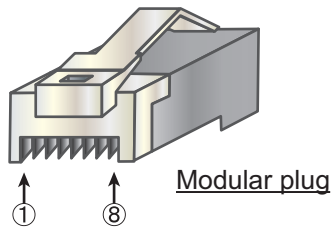

Modular plug

[Crossover cable]

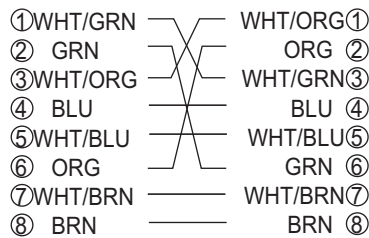

[Straight cable]

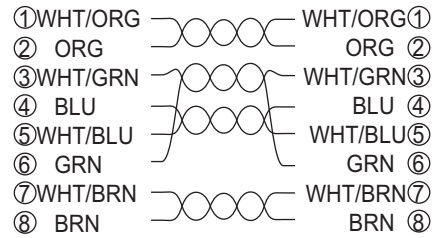

#### **RW-00135 (Antenna cable for FAR-2x18/2x28/2x38 radars)**

For X-band radar, the end of the antenna cable RW-00135 which connects to the Antenna Unit is pre-fabricated.

**RW-0013/RW-0030/03CA00099 (Antenna cable for FAR-2258 radar)**

- RW-0013/03CA00099: No armor

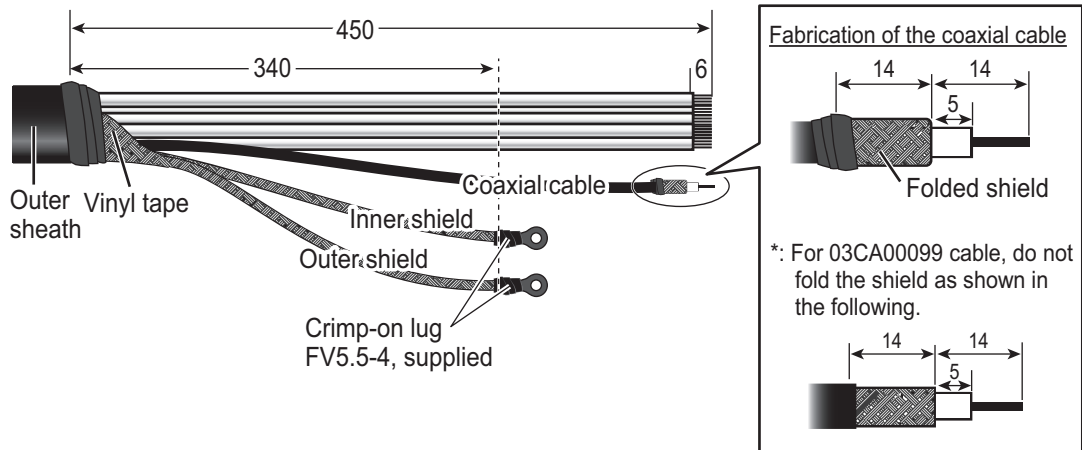

- RW-0030: With armor

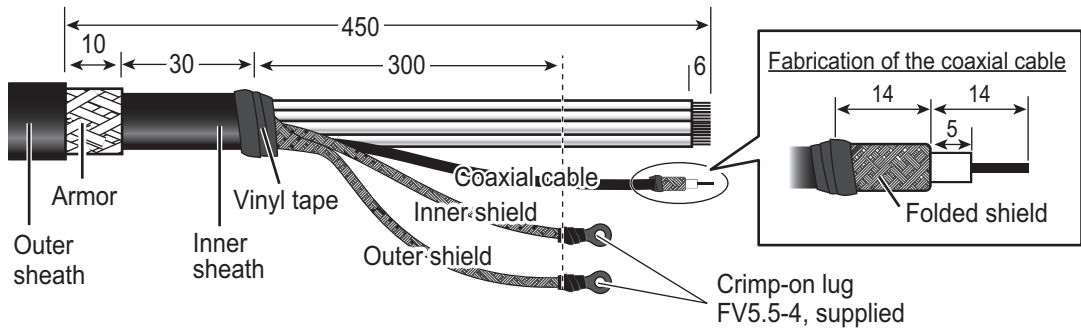

**RW-9600/6895/4873 (for retrofit or foremast installation for FAR-2x18/2x28/2x38 radars)**

The existing cable (RW-9600/6895/4873) can be used for the following cases.

- Cable extension for foremast installation (only for RW-9600 cable)
- Retrofit

Depending on your installation, one or more of the following kits (available as optional extras) may be required. For the LAN Coaxial Converter, see section 2.10 "LAN Signal Converter" and for details.

- LAN Signal Converter: Type: OP03-247-3
- Retrofit Cable Kit: Type: OP03-255-3

Cable type	Antenna specification	Cable entrance	LAN Signal Converter	Retrofit Cable Kit
RW-9600	w/LAN signal converter	Cable cover	—	—
		Bottom of chassis	—	✓
	w/o LAN signal converter	Cable cover	✓	—
		Bottom of chassis	✓	✓
RW-6895 RW-4873	w/o LAN signal converter	Bottom of chassis	✓	✓

("✓": Required, "—": Not required)

## 2. WIRING

**Note:** The maximum antenna cable length is 100 m for RW-9600, 50 m for RW-6895/4873. If the existing antenna cable is longer than the above maximum length, replace the antenna cable with RW-00135.

For wiring the RW-9600 cable via the cable cover, the cable fabrication is shown below. In other cases, see the installation manual in the optional kit.

The unused power lines are tied up and attached to the crimp-on lug FV5.5-S4 (LF), supplied locally. Connect these unused lines to the ground terminal with the shield line. See the interconnection diagram at the back of this manual for details.

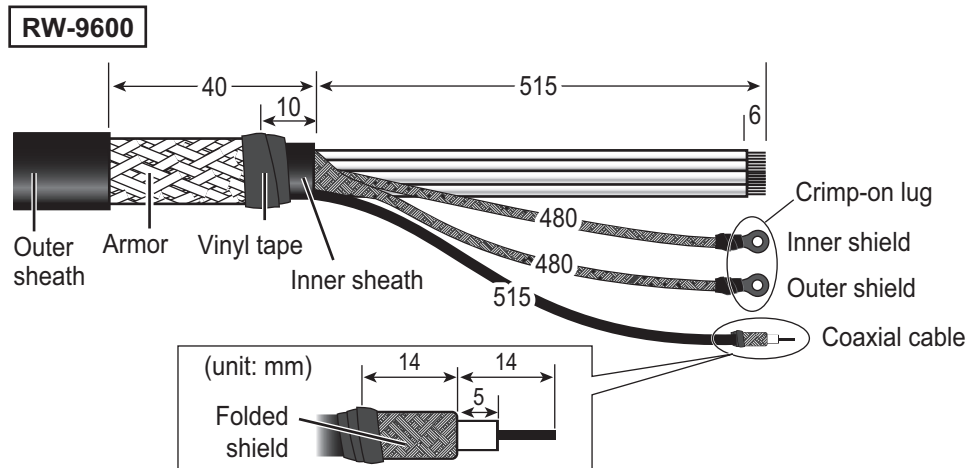

### **S03-92-15/30/40/50 (RW-00136 + connector, for a sub monitor)**

**Note:** The maximum cable length is 50 m.

Clamp the armor with the cable clamp.

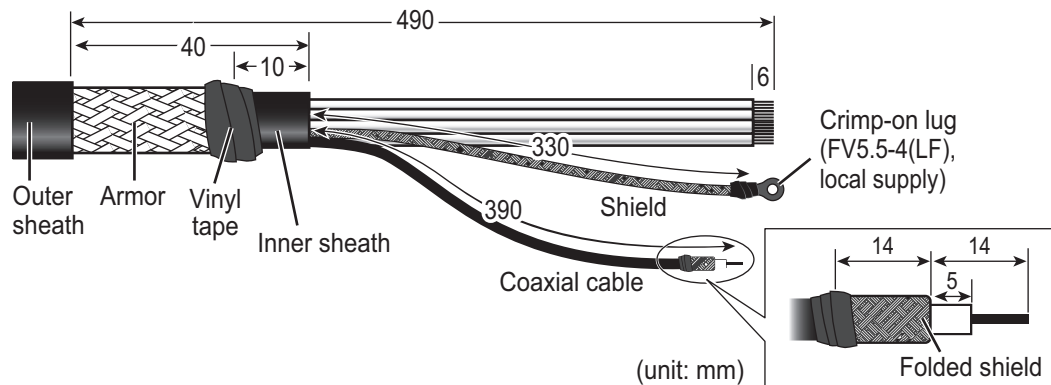

### **DPYCY-1.5 (for the optional de-icer, FAR-2x18/2x28/2x38 radas)**

- Before beginning any work on the Antenna Unit, turn off the breaker for the de-icer at the mains switchboard. (Turning off the display unit has no effect.)
- The de-icer activates when the temperature becomes 0 °C, and shuts down when the temperature reaches 5 °C.

Clamp the armor with the cable clamp.

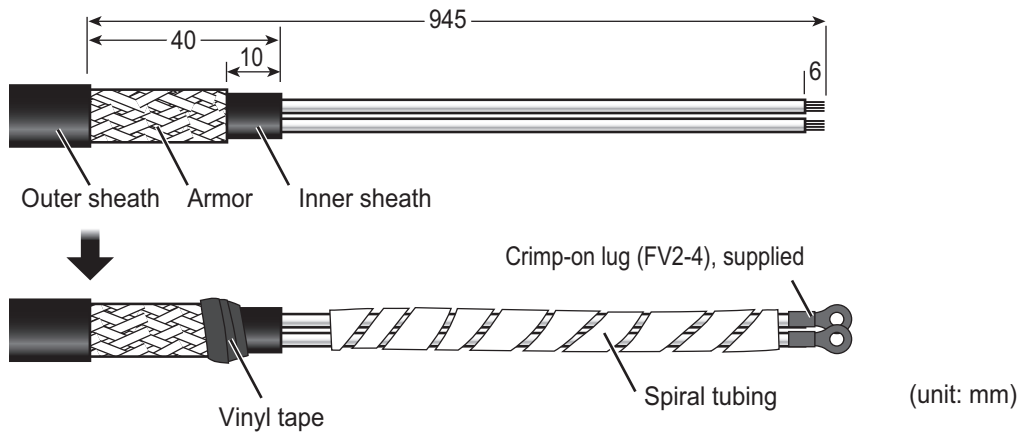

**TPYCY-2.5 (Motor power cable for FAR-2258)**

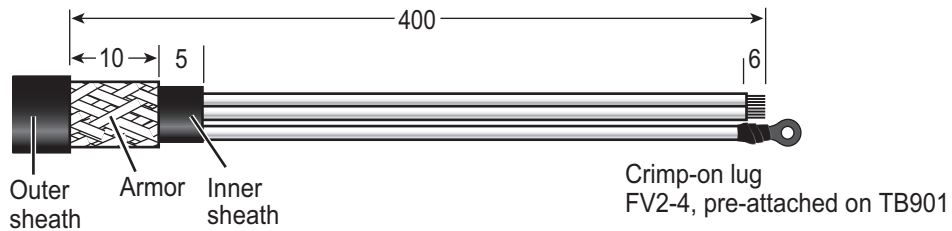

**2.2.2 How to connect the cables for X-band radar (TR-UP, FAR-2x18/2x28/2x38)**

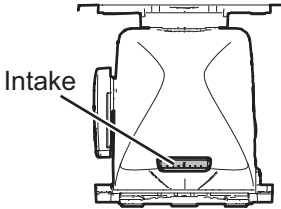
<b>NOTICE</b>	
<p>If there is a chance of inclement weather when the RF unit is removed, cover the intakes on both covers with packing tape for waterproofing. Be sure to remove the tape after completing the installation.</p>	

Some parts or wiring have been omitted from the illustrations for clarity. Also, in the procedure, mainly figures of magnetron radar are shown.

1. Loosen four bolts from the rear cover to remove the rear cover. If the de-icer is already installed, loosen two bolts inside the antenna to remove the front cover.

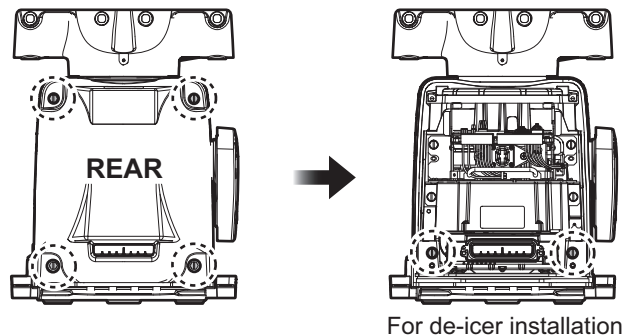

## 2. WIRING

**Note 1:** The cable for the performance monitor is connected between the rear cover and the RF-TB Board in the Antenna Unit. Open the cover slowly to prevent damage to the cable and connector.

**Note 2:** If the de-icer is to be installed, remove four M5 screws and spread open the right and left heater elements on the cover, then remove the front cover, being careful not to hit the elements on the radiator or chassis.

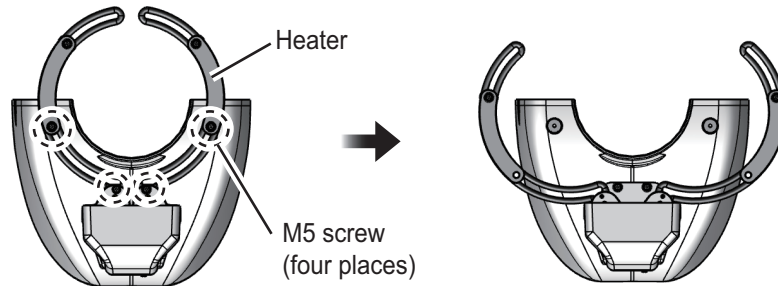

**Note 3:** If this a retrofit or foremast installation, a LAN Signal Converter is required, in both the Antenna Unit and the Processor Unit. See section 2.10.

2. Disconnect the performance monitor connector (J807) and the motor drive connectors (J803, J804 and J808) from the RF-TB Board.

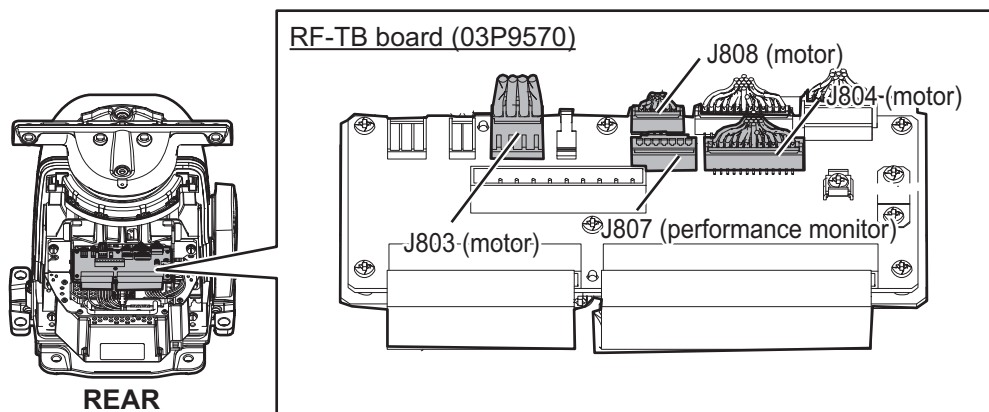

3. Unfasten the six bolts in the figure below to enable removal of the transceiver unit. Then, pull the handle on the transceiver unit to remove the unit. **For magnetron radar, lay the unit on its side or on top of non-ferrous material, to prevent demagnetization of the magnetron**

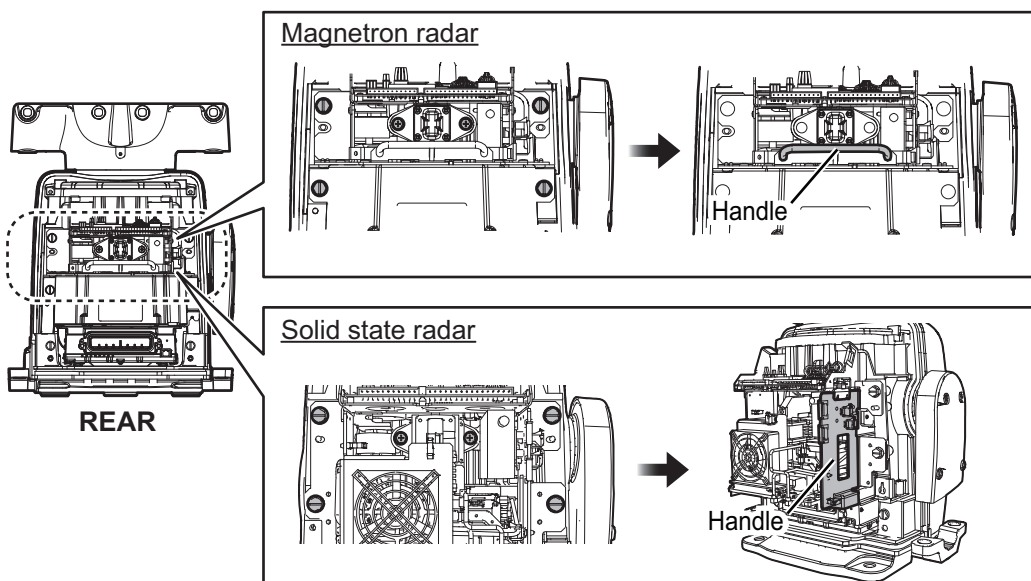



4. Unfasten four screws to open the cable entrance cover.

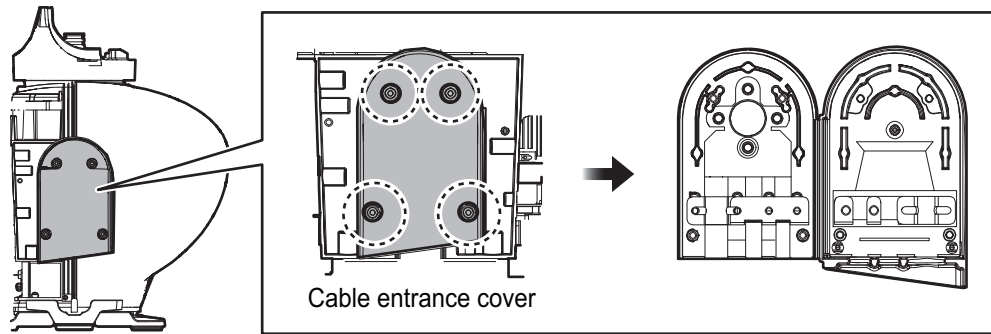

### How to change the orientation

The orientation of the cable entrance can be changed, in one of the three orientations shown in the following figure. **No other orientation is allowed, to maintain watertight integrity.** The default orientation is "deck". To change the entrance, unfasten the four screws circled in the following figure, then orient the cable entrance in the required direction. Refasten the screws.

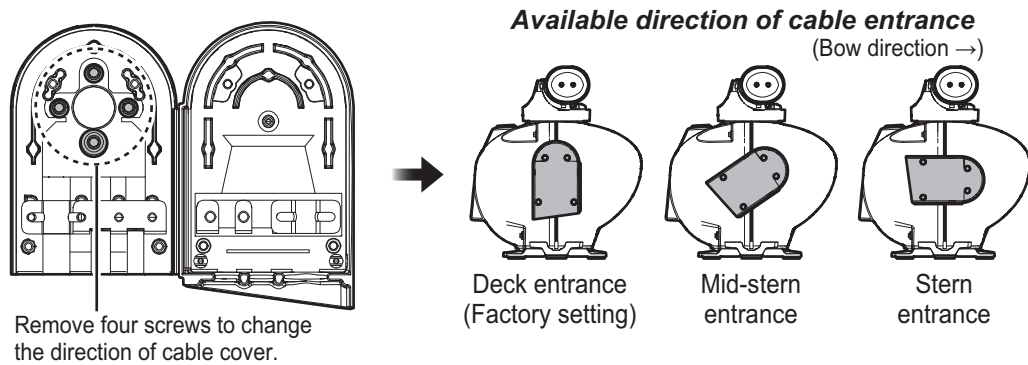

5. Unfasten the two screws fixing the cable clamp for antenna cable, then pass the antenna cable through the cable entrance.

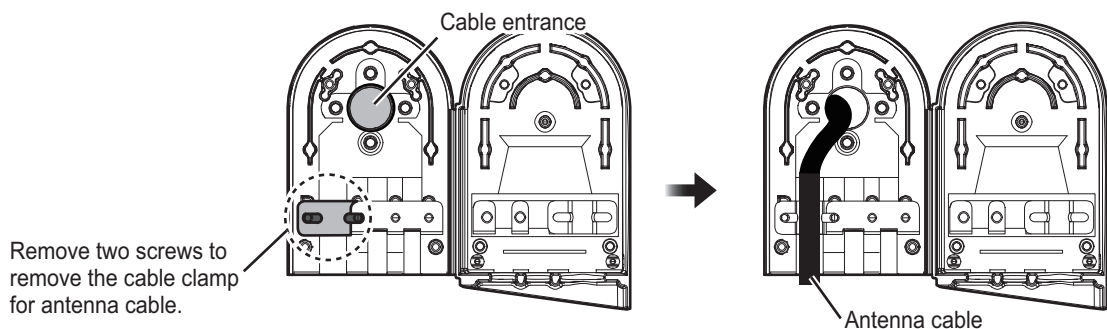

## 2. WIRING

If applicable, unfasten the two screws fixing the cable clamp for the sub monitor and de-icer power cable, then pass the cables through the cable entrance.

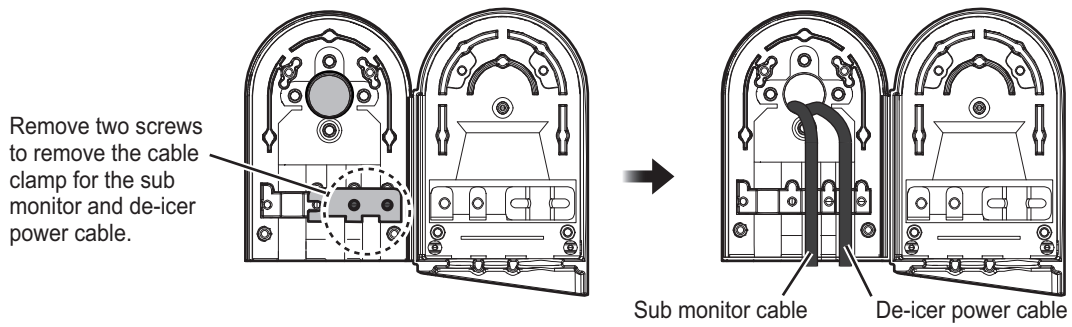

**Note:** Dummy plugs are provided to insert into unused cable slots for waterproofing.

6. Pass the cables through their respective locking wire saddles in the chassis from the cable entrance.

**Note:** Make sure to pass the cable through the specified locking wire saddle.

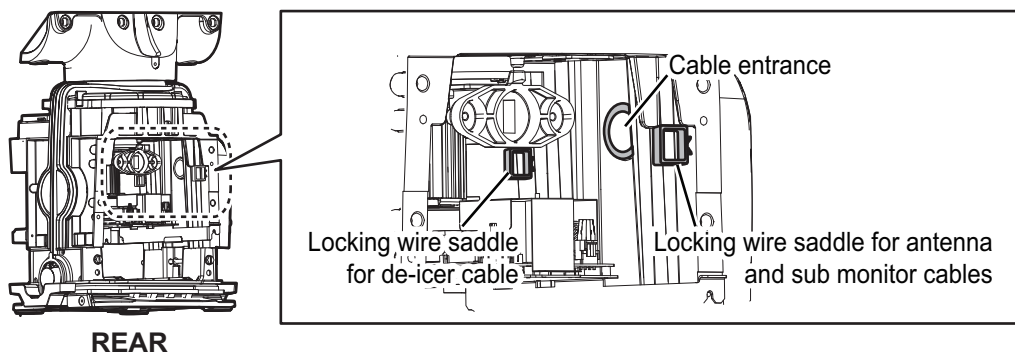

7. Re-mount the transceiver unit then reconnect the connectors for the motor (J803, J804 and J808).
8. Attach the appropriate WAGO connectors (pre-attached) to the appropriate cables, and then connect the antenna and sub monitor cables to the RF-TB Board as shown in the following figure. For how to connect the WAGO connector, see "WAGO connector" on page 2-5. For pin arrangement, see the interconnection diagram at the back of this manual.

**Note 1:** Make sure to pass the cable through the specified locking wire saddle.

**Note 2:** A terminal opener is provided on the RF-TB Board.

- Destination of antenna cable

**Power line:** TB801 through the locking wire saddles (A, two places).

**LAN cable:** J821 through the locking wire saddles (B, two places).

**Shield of power line:** Screw on fixing plate (C)

**Shield of LAN cable:** Screw (D)

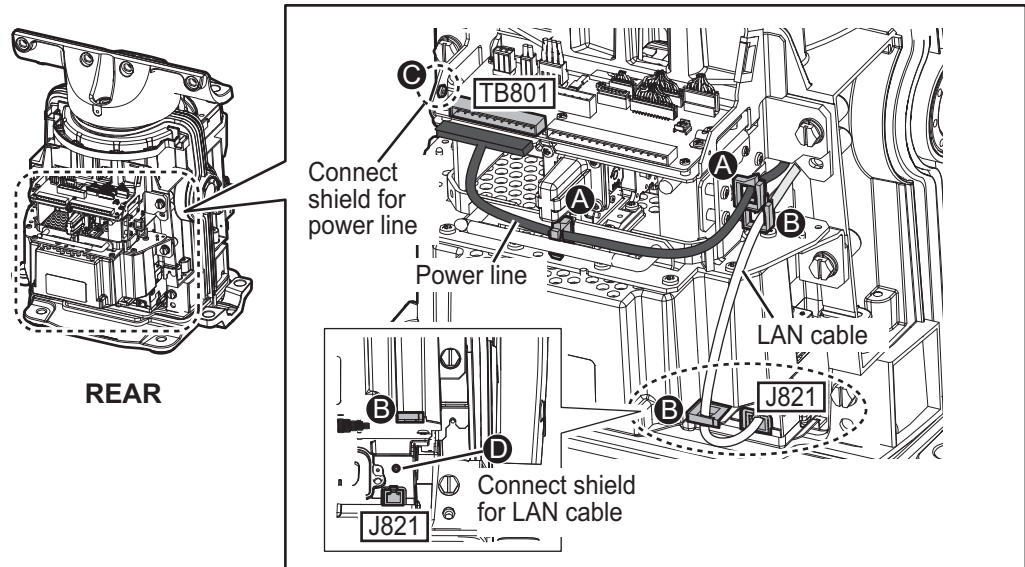

**Note:** For the antenna cable RW-9600/6895/4873, connect the crimp-on lug (that binds unused wires) together with the shield of the power line.

● Destination of sub monitor cable

**Signal line:** TB803 through the locking wire saddle (A).

**Coaxial cable:** TB804 (B)

**Shield of signal cable:** Screw on fixing plate (C)

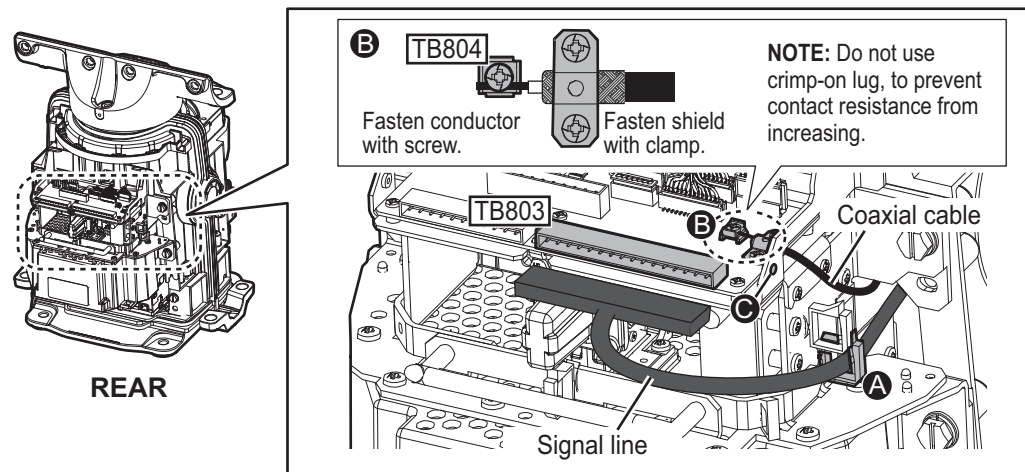

9. **For DE-ICER INSTALLATION**, connect the de-icer power cable the de-icer board 03P9573 attached on the front cover. If the de-icer is not provided, go to step 10.

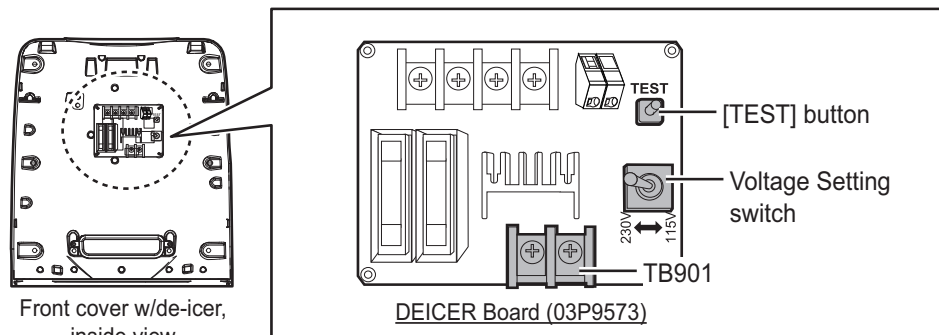

## 2. WIRING

- 1) Set a locking wire saddle (supplied) at locations (B) and (C) shown in the following figure. Pass the de-icer power cable from cable entrance through the locking wire saddles (A), (B) and (C) and pull it to the front side.

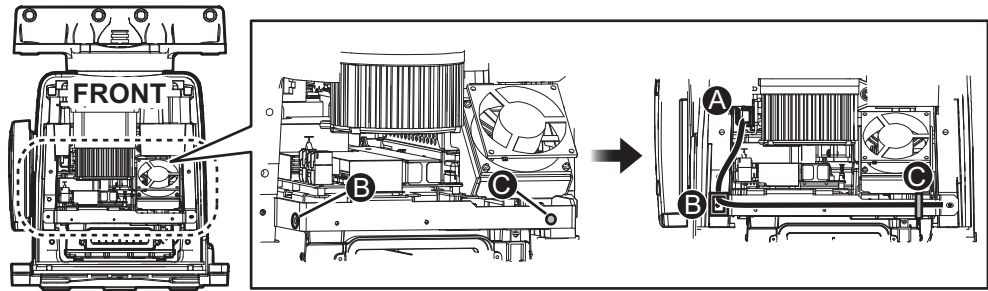

- 2) Pass the de-icer power cable through the cable band. Connect the cable to TB901 on the DE-ICER board (03P9573), using the supplied crimp-on lugs.
- 3) Set the Voltage Setting switch according to the power source for the de-icer; 115 V or 230 V. The default setting is 230 V.
- 4) Apply power to the de-icer then press and hold the **TEST** button for about ten seconds. Check that the heater gets hot and then release the **TEST** button.
- 5) Coat the gasket (all brims) of the intake with the supplied oil compound. Be sure to coat the gasket completely.

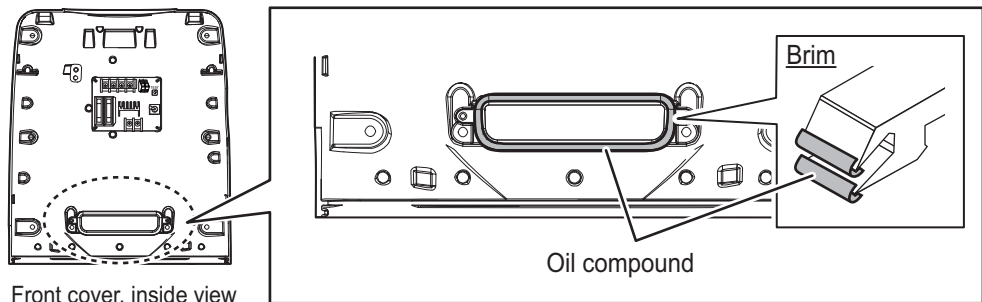
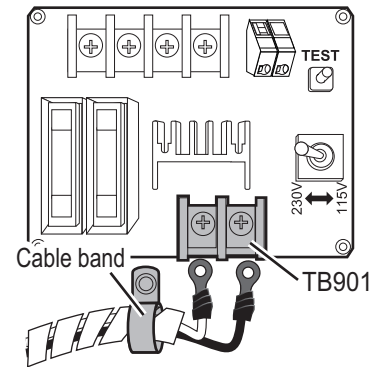

- 6) Set the front cover to the Antenna Unit. Close the open heater and return to its original position. Take care not to hit the heater elements on the chassis or radiator.
- 7) Fasten the base of the heater with two M5 screws and apply the adhesive the screw heads. Also, fasten the fixing shafts for the cover bolts with two M5 screws.

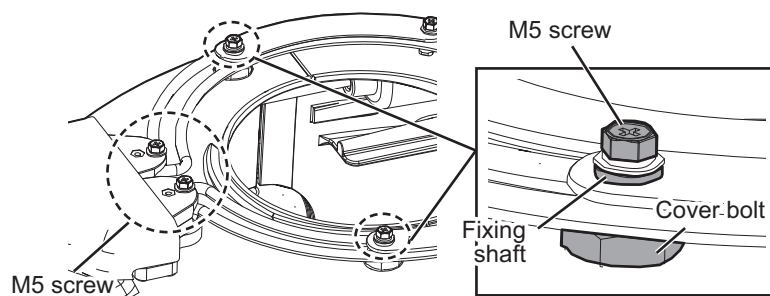

10. Position the cables so their armors lie beneath their respective cable clamps in the cable entrance. Fasten the cable clamps.

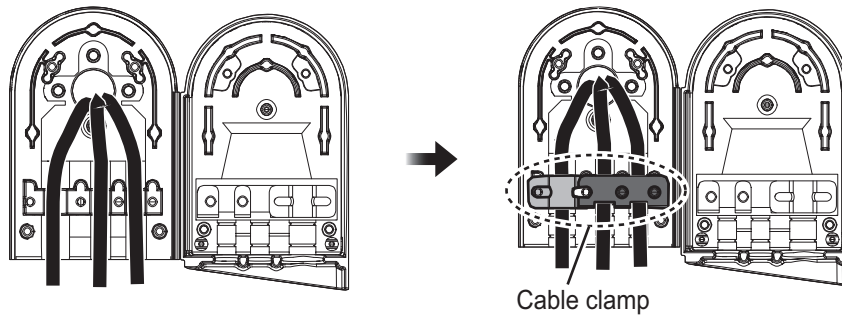

11. Coat the hinge with the supplied adhesive for hinge waterproof then close the cable entrance cover. Fix the cable cover with four screws, then coat the screws with the supplied adhesive.

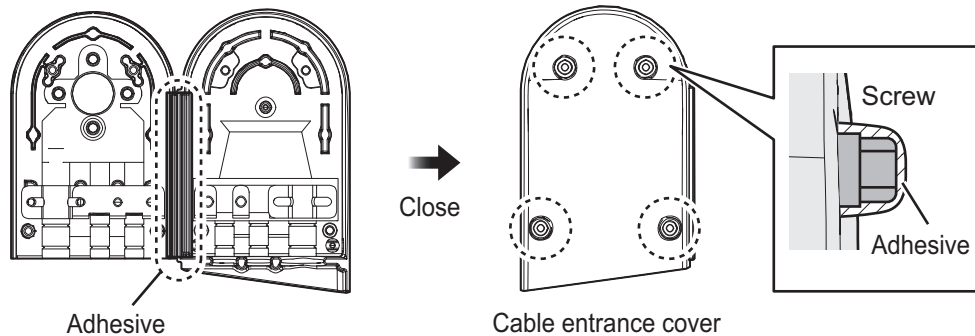

12. Reconnect the performance monitor connector (J807) to the rear cover.
13. **Check that the gasket on the front and rear covers is seated properly**, then close the covers. The torque for the fixing bolts must be 10.0 N•m.
- Note 1:** If it is necessary to open the front cover after installing the de-icer kit, remove the de-icer power cable from the locking wire saddle as shown in the following figure, then detach the cover slowly to prevent damage to the heater element.

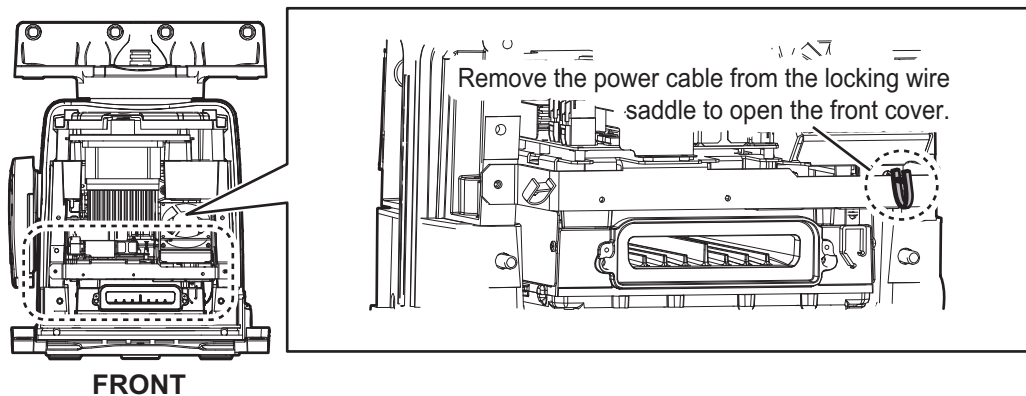

- Note 2:** For the de-icer, take care not to hit the heater elements on the chassis or radiator. If the heater hits something, unfasten the fixing screws for the heater to adjust the position of the heater. Then fix the heater again.