

Installation Manual MARINE RADAR FAR-1467DS/1467DS-BB

SAFETY INSTRUCTIONS	i
SYSTEM CONFIGURATION	iii
EQUIPMENT LISTS	iv
1. MOUNTING	1
1.1 Antenna Unit	8
1.2 Control Unit	8
1.3 Processor Unit	10
1.4 Power Supply Unit	11
2. WIRING	12
2.1 Interconnection	12
2.2 Antenna Unit	13
2.3 Processor Unit	18
2.4 Power Supply Unit	23
2.5 Changing AC Power Specification of Processor Unit	25
2.5.1 Processor Unit	25
2.5.2 Power Supply Unit	26
2.6 Interswitch	27
2.7 Connection to CAN bus Network	28
3. SETTING AND ADJUSTMENT	29
3.1 Setting Initial Setting Wizard	29
3.2 Initializing Tuning	43
3.3 Adjustment of Video Level	44
3.4 Heading Alignment	45
3.5 Adjustment of Sweep Timing	46
3.6 Suppressing Main Bang	47
3.7 Gyrocompass Signals	48
4. Input Signal	54
4.1 NMEA Input Sentence	54
4.2 NMEA Output Sentence	56
4.3 CAN bus port Input/output	57
PACKING LISTS	A-1
OUTLINE DRAWINGS	D-1
INTERCONNECTION DIAGRAMS	S-1

ECF

(Elemental Chlorine Free)

The paper used in this manual
is elemental chlorine free.

FURUNO ELECTRIC CO., LTD.

9-52 Ashihara-cho,
Nishinomiya, 662-8580, JAPAN

• FURUNO Authorized Distributor/Dealer

All rights reserved.

Printed in Japan

Pub. No. IME-36120-Z

(HIMA) FAR-1467DS/1467DS-BB

A : 0000

Z : MAR. 27, 2012



* 0 0 0 1 7 5 8 0 8 1 0 *



SAFETY INSTRUCTIONS

The installer must read and follow all the safety instructions before attempting to install the equipment.



DANGER

Indicates a potentially hazardous situation which, if not avoided, will result in death or serious injury.



WARNING

Indicates a potentially hazardous situation which, if not avoided, could result in death or serious injury.



CAUTION

Indicates a potentially hazardous situation which, if not avoided, may result in minor or moderate injury.



Warning, Caution



Prohibitive Action



Mandatory Action



DANGER



Wear a safety belt and hard hat when working on the antenna unit.

Serious injury or death can result if someone falls from the radar antenna mast.



WARNING

Radio Frequency Radiation Hazard



The radar antenna emits electromagnetic radio frequency (RF) energy which can be harmful, particularly to your eyes. Never look directly into the antenna aperture from a close distance while the radar is in operation or expose yourself to the transmitting antenna at a close distance.

Distances at which RF radiation levels of 100 W/m² and 10 W/m² exist are given in the table below.

Note: If the antenna unit is installed at a close distance in front of the wheel house, it may be necessary to halt transmission within a certain sector of antenna revolution. This can be done from the SCANNER menu.

Radiator type	Distance to 100 W/m ² point	Distance to 10 W/m ² point
SN24AF	0.6 m	8.5 m
SN30AF	0.6 m	7.7 m

WARNING



Construct a suitable service platform from which to install the antenna unit.

Serious injury or death can result if someone falls from the radar antenna mast.



Turn off the power at the switchboard before beginning the installation.

Fire, electrical shock or injury can result if the power is on during the installation.



Do not install units other than the antenna unit in a place subject to rain or water splash.

Fire, electrical shock or injury can result if water leaks into those units.



Do not open the equipment unless totally familiar with electrical circuits and service manual.

Only qualified personnel should work inside the equipment.



Use only the specified power cables.

Use of power cables that are thinner than those specified can cause fire.



Securely attach protective earth to the ship's body.

The protective earth is required to prevent electrical shock.

CAUTION



A proper license is necessary to install a radar.

See your dealer for details.



Observe the following compass safe distances to prevent interference to a magnetic compass:

	Standard compass	Steering compass
Antenna Unit (60 kw)	4.10 m	2.65 m
Processor Unit (RPU-021)	2.35 m	1.50 m
Control Unit (RCU-021)	0.30 m	0.30 m
Monitor Unit (MU-190HD)	1.05 m	0.65 m

SYSTEM CONFIGURATION

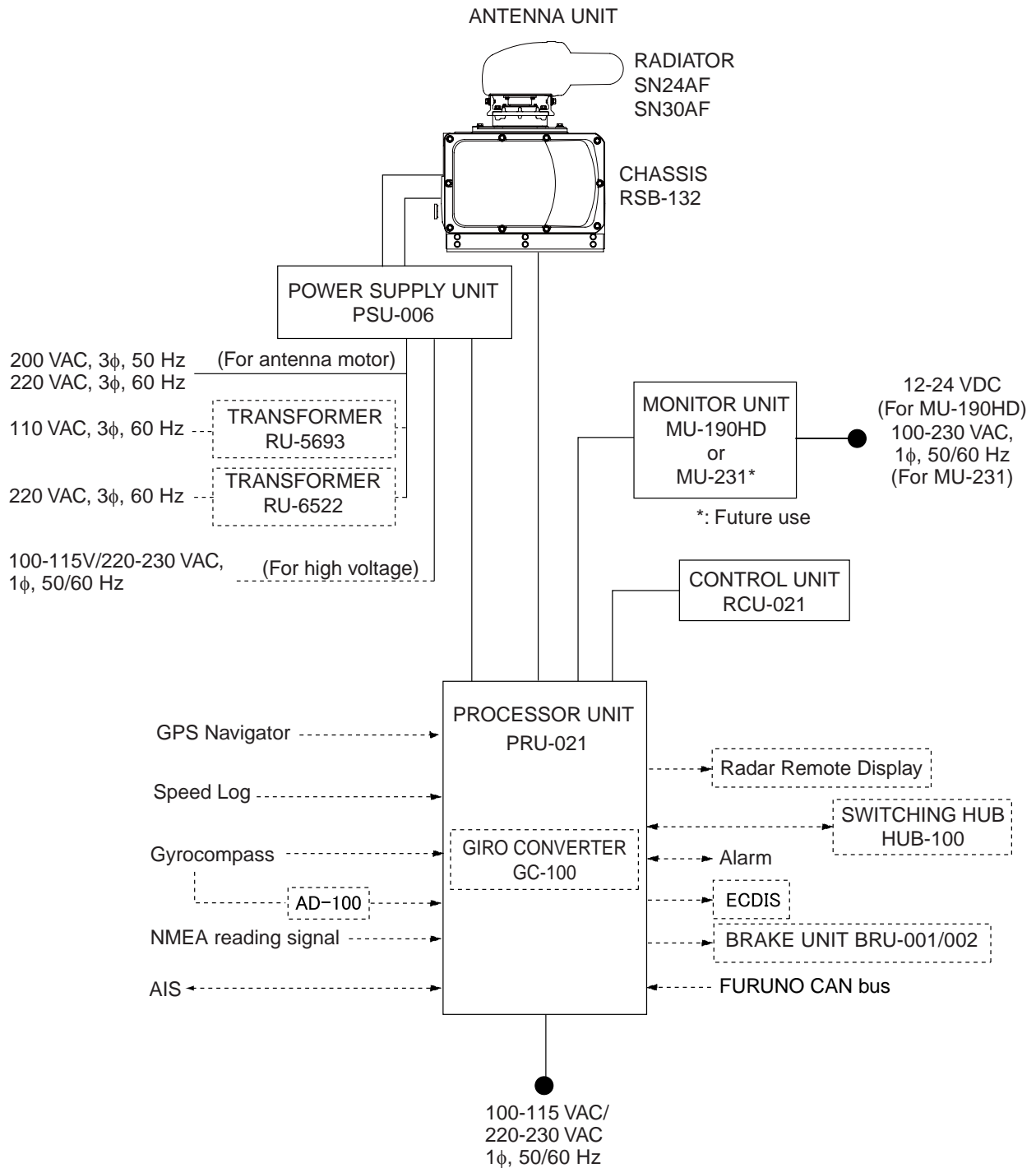

Equipment category

Unit	Category
Antenna	Exposed to weather
Other units	Protected from weather

EQUIPMENT LISTS

Standard Supply

Name	Type	Code No.	Qty	Remarks
Antenna Unit	SN24AF-RSB-132-110	-	1	2400 mm
	SN30AF-RSB-132-110	-		3000 mm
Processor Unit	RPU-021	-	1	
Monitor Unit	MU-190HD	-	1	
	MU-231	-		Future use
Control Unit	RCU-021	-	1	
Power Supply Unit	PSU-006	-	1	
Installation Materials	CP03-33300	000-017-041	1	15 m signal cable RW-0013
	CP03-33310	000-017-042		20 m signal cable RW-0013
	CP03-33320	000-017-043		30 m signal cable RW-0013
	CP03-31501	000-573-780		For antenna unit
	CP03-34301	001-169-300		For antenna unit
	CP03-31401	008-572-750		For power supply unit
	CP03-33330	000-017-053		For processor unit
	CP03-33200	000-017-258		For control unit
Spare Parts	SP03-15501	008-572-730	1	For power supply unit, 100 VAC
	SP03-15502	008-572-740		For power supply unit, 220 VAC
	SP03-16301	001-104-910		For power supply unit, 100 VAC
	SP03-16302	001-104-920		For power supply unit, 220 VAC
Accessories	FP03-10101	008-538-730	1	For antenna unit

Optional Equipment

Name	Type	Code No.	Remarks
Gyro Converter	GC-100-2	000-017-044	Shipped separately
Transformer Unit	RU-1803	-	440 to 100 VAC, for processor unit
Cable Assy.	RW-4864 1M	001-103-620-10	Radar signal cable, 1m
	RW-4864 5M	001-103-630-10	Radar signal cable, 5m
	RW-4864 10M	001-103-640-10	Radar signal cable, 10m
	RW-4864 15M	001-103-650-10	Radar signal cable, 15m
	DVI-D/D SINGLELINK 5M	000-149-054-10	DVI cable for monitor, 5m
	DVI-D/D S-LINK 10M	000-150-200-11	DVI cable for monitor, 10m, MU-190H only
	RNS-08-132	000-174-105-10	To adjust the brilliance of the display unit. USB cable 5m
Switching Hub	HUB-100	-	See the operator's manual for HUB-100.
F Mount Fixture	OP03-212	001-115-440	For control unit (flash mount)
Attachment Base For 2165DS	OP03-219	001-163-800	For retrofit from FR-2165DS/ 1460DS/1760DS/2160DS

1. MOUNTING

This chapter explains installation of the antenna unit, the control unit and the processor unit and the power supply unit. For installation of the monitor unit, please refer to the installation manual attached to the monitor unit.

NOTICE

Do not apply paint, anti-corrosive sealant or contact spray to coating or plastic parts of the equipment.

Those items contain organic solvents that can damage coating and plastic parts, especially plastic connectors.

1.1 Antenna Unit

Mounting considerations

Please note the following when mounting the antenna unit.

- Install the antenna unit either on top of the wheelhouse or on the radar mast, on a suitable platform clear of any structures to avoid beam interferences. Install the platform horizontally. Install safety measures such as handrail to safely perform maintenance.
- A line of sight from the antenna unit to the bow of the ship should be the shorter of the following two distances.
 - Under 500m
 - Not more than twice the ship's length

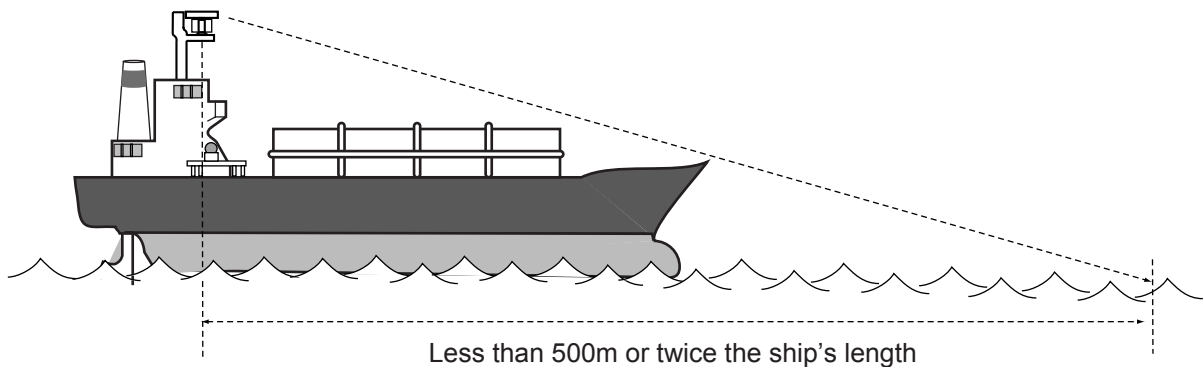

Mount the antenna unit as high position as possible to detect targets as far as possible.

- Mount the antenna unit so that any blind sectors caused by objects (funnel, mast, etc.) are kept to a minimum. Note the following considerations;
 - No blind sectors should exist in the gray areas shown below.
 - Any individual blind sector should be no more than 5° . Should multiple blind sectors occur, the total of such blind sectors should not exceed 20° . Any two blind sectors separated by 3° or less are regarded as one sector. (Fig. 2)

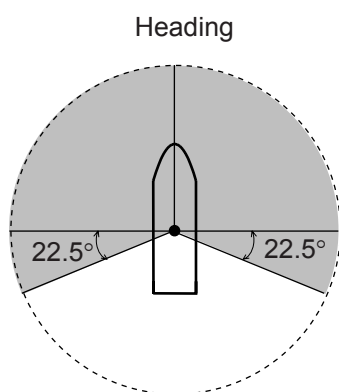
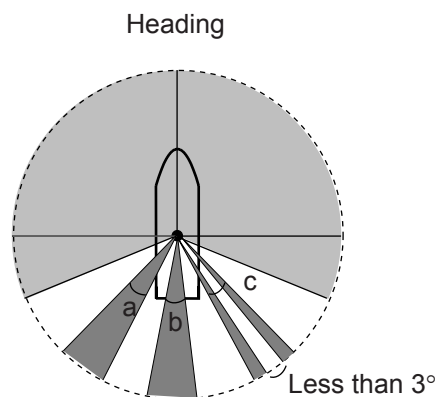

Fig. 1



a, b, c: Less than 5° respectively.
a+b+c+...: Less than 20°

Fig. 2

- Install the antenna unit away from interfering high-power energy sources and other transmitting radio antennas.
- Keep the lower edge of the antenna unit above the safety rail by 500mm or more.
- Two antenna units should be mounted as below:

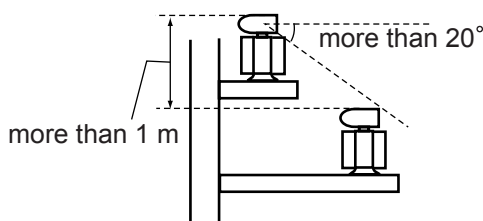

- No funnel, mast or derrick should be within the vertical beam width of the antenna unit in the bow direction, especially zero degrees $\pm 5^\circ$ to prevent blind sectors and false echoes on the radar picture.
- Do not install the antenna unit near a magnetic compass. Secure the safety distance shown on page ii to prevent errors in the magnetic compass.
- Do not paint the radiator aperture.
- The antenna base is made of cast aluminum. To prevent electrolytic corrosion of the antenna base, use the seal washers and corrosion-proof rubber mat and ground the unit with the ground wire (supplied).
- No funnel or other exhaust vent shall exist near the antenna unit. The antenna unit must not be mounted where the temperature is more than 55°C. Deposits and fumes from a funnel or other exhaust vent can adversely affect the aerial performance and hot gases may distort the radiator portion.
- Leave sufficient space around the unit for maintenance and servicing. See the antenna unit outline drawing for recommended maintenance space.

Installation precaution for S-band antenna unit

If an S-band antenna unit is mounted near the end of a platform to provide sufficient rotation clearance for the radiator, the antenna unit, because of its weight, will swing up and down by ship's vibration and rolling. This exerts excessive levels of stress at the base of the radiator, which can damage the radiator. To prevent this, relocate the antenna unit, or if relocation is not possible reinforce the platform.

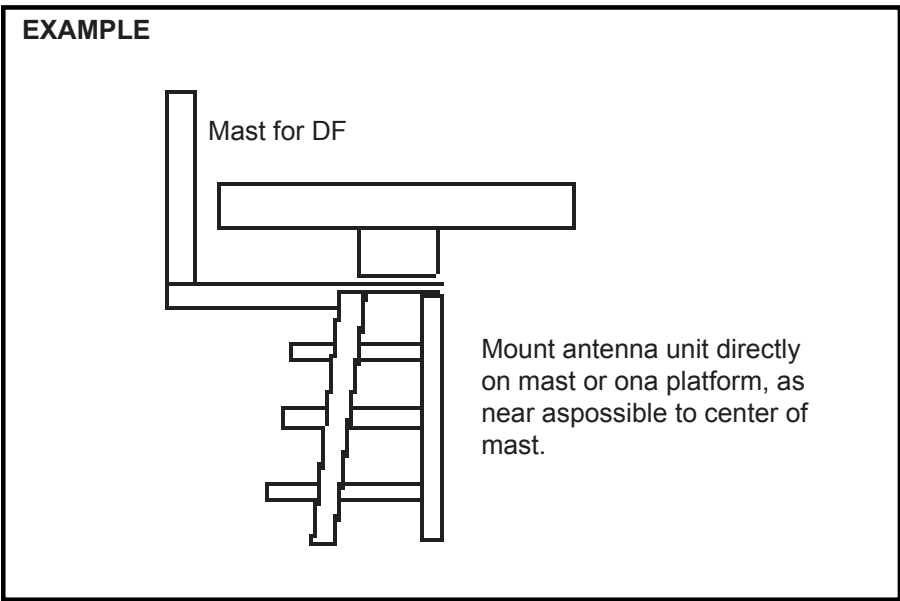
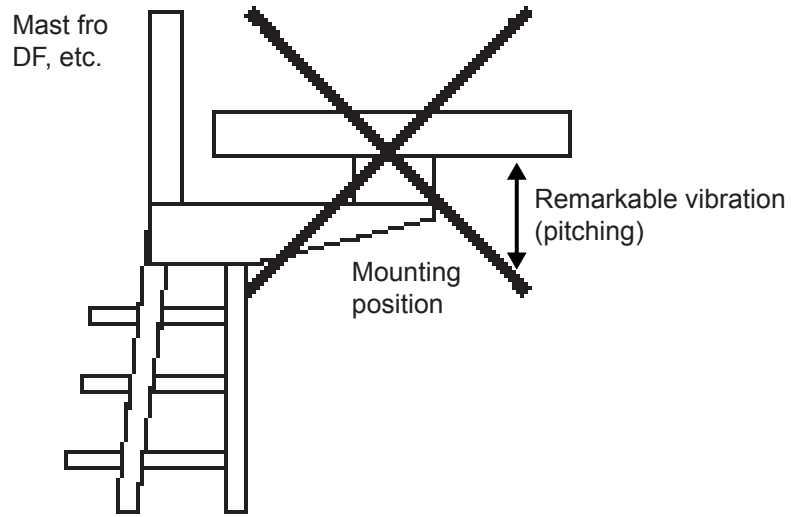

Mounting precaution for S-band antenna unit

Assembling the antenna unit

The antenna unit should be assembled before mounting it. Follow the procedure below to assemble the antenna unit.

1. Screw the guide pins (2 pcs.) in the radiator.
2. Remove the protective cap from the choke guide and radiator.
3. Grease the O-ring and set it to the groove on the choke guide.
4. Place the radiator on the radiator bracket. (Radiator direction is shown by the logo on the bracket. If reversely oriented the radiator cannot be set to the bracket.)
5. Loosely fix the radiator to the radiator bracket with hex bolts (M10x25), spring washers and flat washers.
6. Remove the guide pins and tighten the hex bolts.

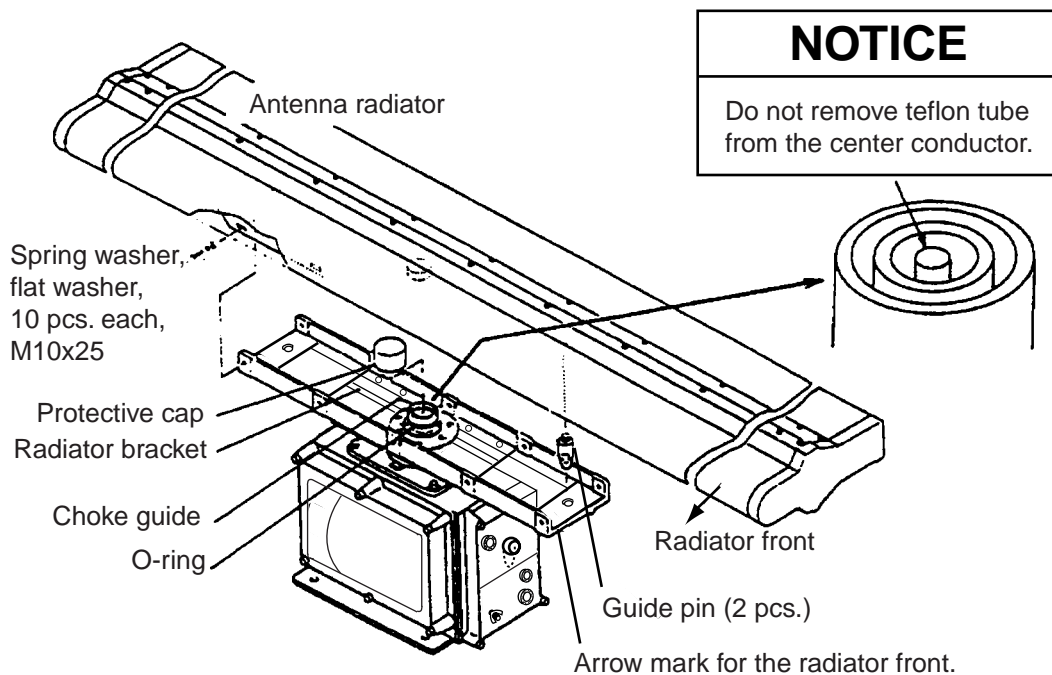

CAUTION

Be sure to remove the guide pins after fixing the radiator.

Injury may result if the guide pins loosen and fall from antenna radar platform.

Assembling the antenna unit



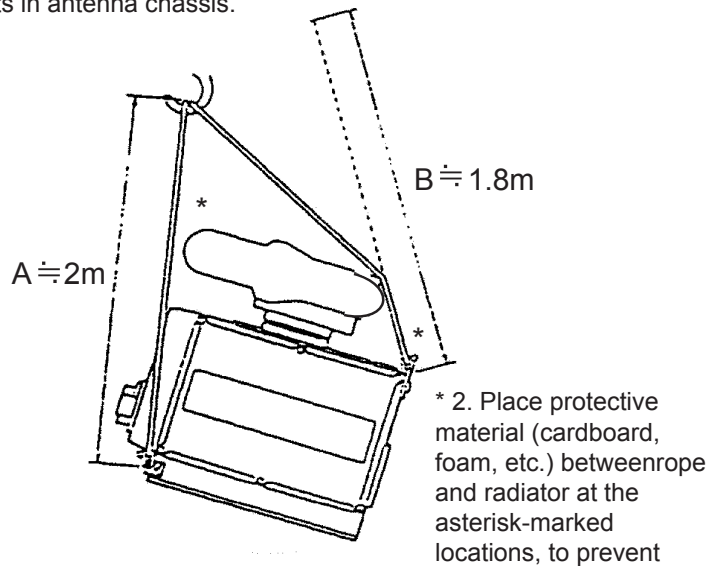
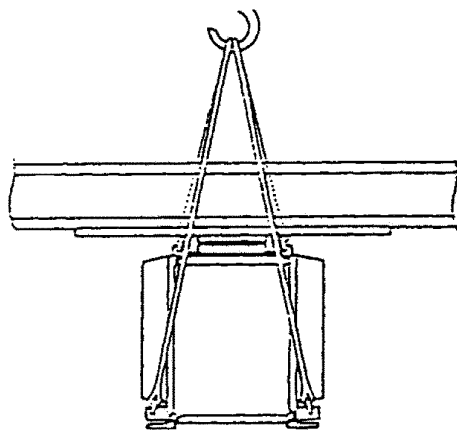
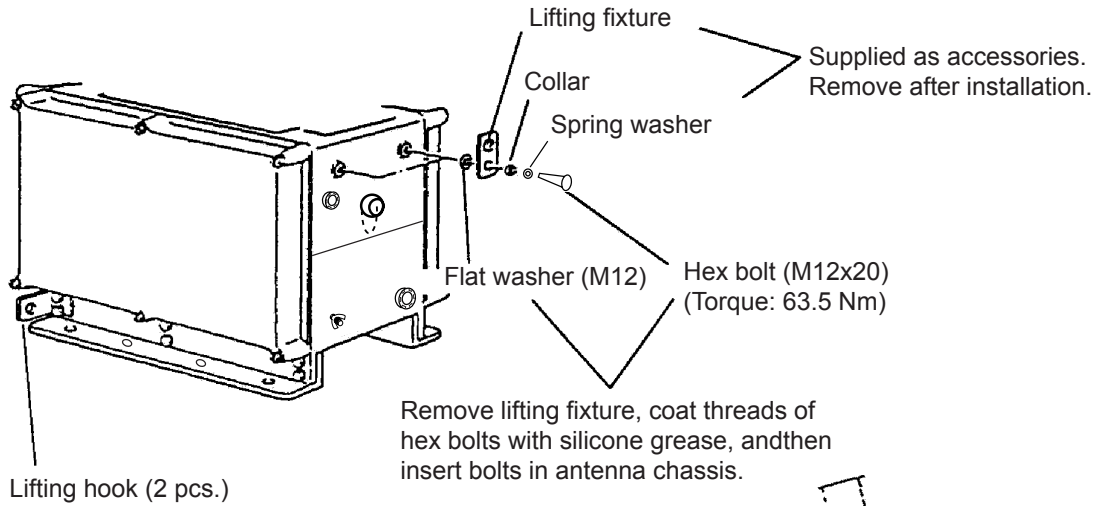

How to hoist the antenna unit

- 1) Fix the antenna radiator to the antenna unit chassis as shown on page 1-3.
- 2) Attach the lifting fixtures and collars as shown below.
- 3) Position the radiator as shown below and arrange the ropes A and B.



Attachment of lifting fixtures, collar and ropes

Fastening the antenna unit to the mounting platform

 WARNING	
	<p>Wear a hard hat and safety belt when mounting the antenna unit.</p> <p>Serious injury or death can result if someone falls from the radar antenna mast.</p>
	<p>Construct a suitable service platform from which to install the antenna unit.</p> <p>Serious injury or death can result if someone falls from the radar antenna mast.</p>
	<p>Do not open the equipment unless totally familiar with electrical circuits and service manual.</p> <p>Only qualified personnel should work inside the equipment.</p>

Note: The antenna is made of cast aluminum, which is subject to electrolytic corrosion if the mounting platform is steel or iron. To prevent electrolytic corrosion, use the supplied seal washers and corrosion-proof rubber mat.

Fix the antenna unit to the mounting location, referring to the procedure below and the illustration on the next page.

1. Referring to the antenna outline drawing, prepare a mounting platform. Drill eight fixing holes of 15 mm in diameter in the mounting platform or the deck.
 - The diameter of the mast for the mounting platform must be over 250 mm.
 - The thickness of the platform must be over 15 mm.
 - The thickness of the platform must be over 15 mm.

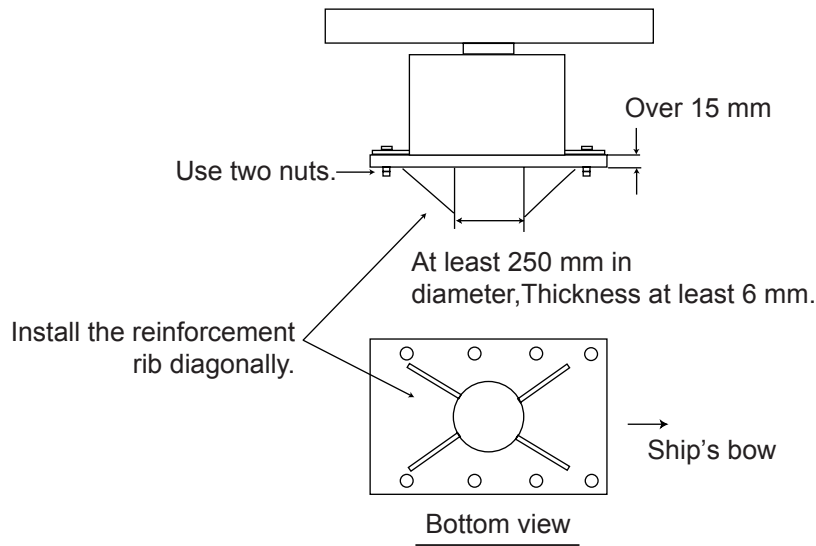

The thickness of the platform must be over 15 mm.

2. Lay the corrosion-proof rubber mat (supplied) on the mounting platform, aligning the holes on the rubber mat with the fixing holes on the mounting platform.
3. Lay the antenna unit on the rubber mat, orienting it so the cable gland is directed toward ship's bow. Remove the lifting fixtures and collars.
4. Fix the antenna base to the mounting platform with four M12?70 hex bolts, nuts, washers and seal washers (supplied).
5. Arrange the ground point at a location on the mounting platform that is within 300 mm from the ground terminal on the antenna unit. Fasten the ground wire (RW-4747, 340 mm) there, using the M6?25 hex bolt, nut and washers.
6. Connect the other end of the ground wire to the ground terminal on the antenna unit.
7. Coat the ground terminal, ground point on the mounting platform and fixing bolts on the antenna unit with anticorrosive sealant (supplied).

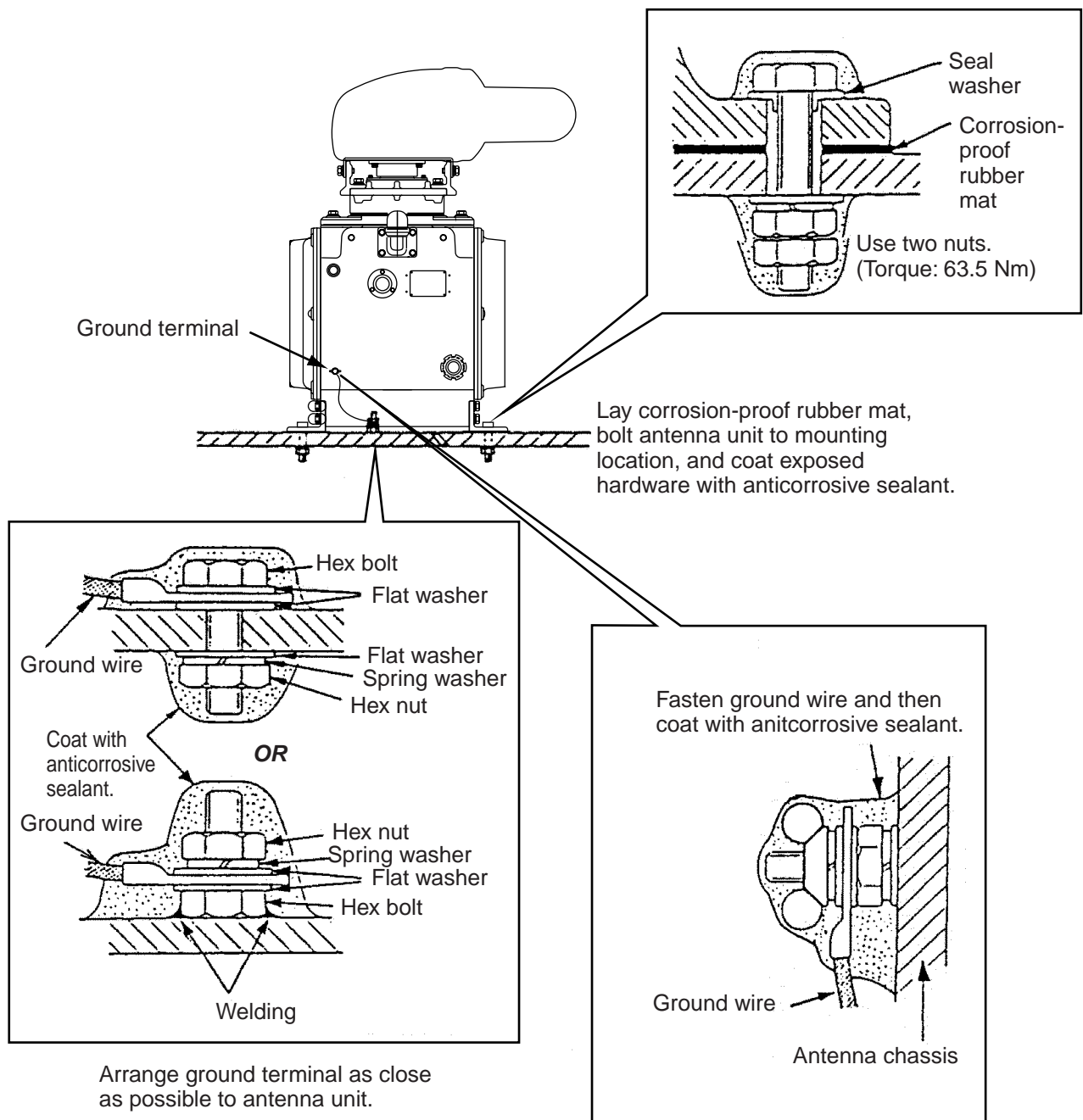

Ground terminal provided on antenna base.

Mounting the antenna unit

1.2 Control Unit

Please note the following when mounting the control unit.

- Select a location where the control unit can be operated conveniently.
- Locate the unit out of direct sunlight.
- Locate the unit away from places subject to water splash and rain.
- Determine the mounting location considering the length of the signal cable between the control unit and the processor unit. The signal cable is shipped already attached to the control unit.
- Distance between the control unit and a magnetic compass should be more than the compass safe distance (See page ii.)

Desktop mounting using KB mounting metal

1. Fasten the KB mounting metal with four tapping screws (5x20) to the mounting location. Note the correct orientation. The cutout is on the rear side.

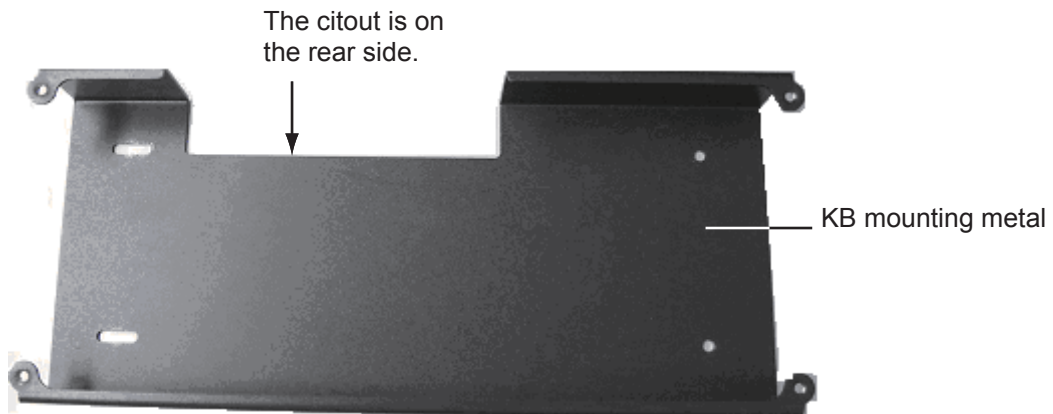

2. Place the control unit on the KB mounting metal and fix it with small binding screws (M5x12) and 4- wave washers.



Control unit on top of KB mounting metal

Note: Connect the grounding wire before installation because the grounding terminal of the control unit is located on the bottom of the unit.

3. Fit the screw cap supplied into mounting holes.

1.3 Processor Unit

Mounting location

Note the following when selecting a mounting location.

- Locate the unit away from heat sources.
- Locate the unit away from places subject to water splash and rain.
- Leave sufficient space around the unit for maintenance and servicing. See the outline drawing for recommended maintenance space.
- Distance between the unit and a magnetic compass should be more than the safety distance shown on page ii.

Mounting procedure

Fasten the processor unit with N6 bolts or tapping screws. Refer to the outline drawing at the end of this manual.

1. When mounting the unit on a wall with tapping screws, prepare holes matching the screw size.
2. Insert the tapping screws (6x30) into the two prepared holes on the upper side and loosely screw in the tapping screws.
3. Tighten the tapping screws completely after hooking the unit on the upper tapping screws.
4. Tighten the tapping screws completely in the prepared holes on the lower side.

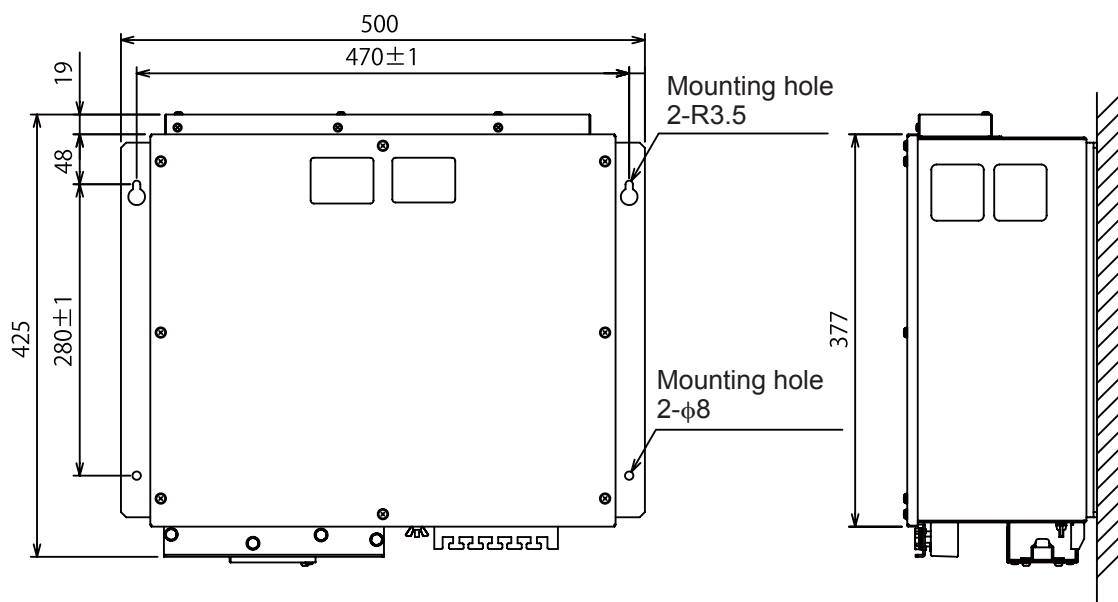

1.4 Power Supply Unit

Mounting considerations

The power supply unit may be mounted on a bulkhead or a deck. Because it has no operation requirements it can be located almost anywhere, provided the location is well ventilated.

Mounting procedure

Fix the unit to the mounting location with four 6?20 self-tapping screws (local supply). For mounting on a bulkhead, do the following:

1. Mark location for mounting holes.
2. Screw in the self-tapping screws at the location for the bottom fixing holes, leaving a gap of about 5 mm between the bottom of the screw head and bulkhead.
3. Set the unit to the screws inserted at step 1.
4. Fasten the self-tapping screws at the top of the unit.
5. Tighten all self-tapping screws.

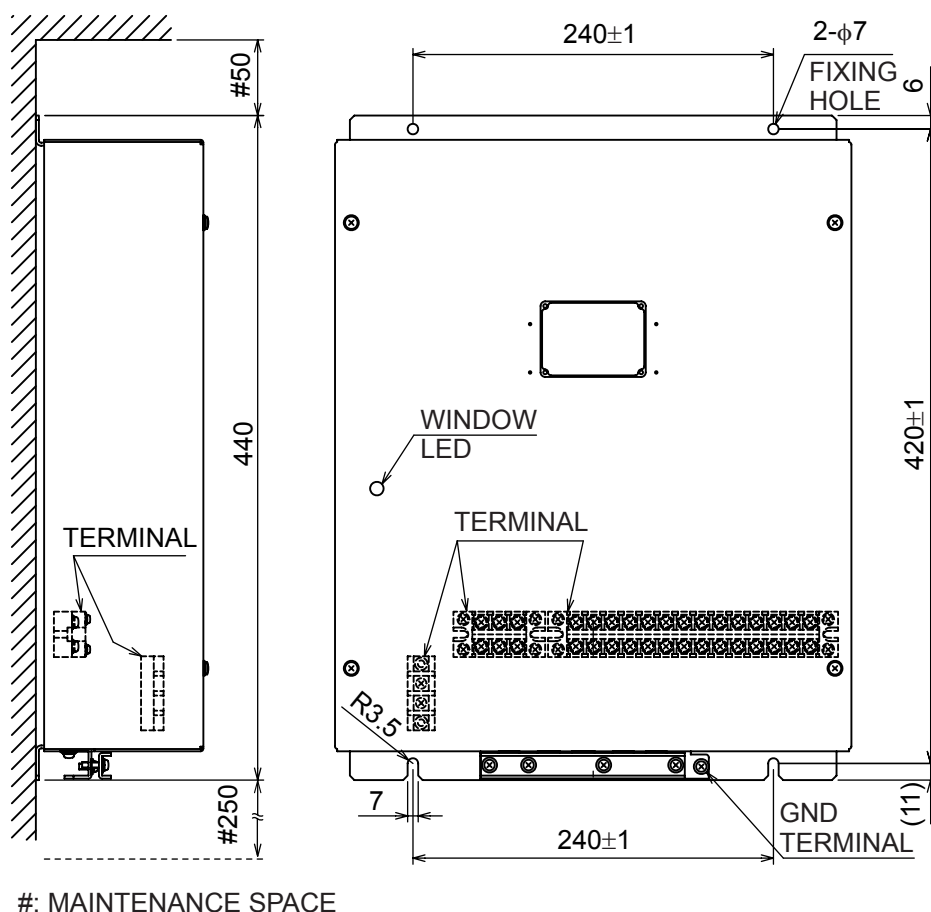

Mounting dimensions for power supply unit

2. WIRING

Please note the following when wiring.

- To lessen the chance of picking up electrical interference, avoid where possible routing the signal cable near other onboard electrical equipment, especially other radars, transmitting radio antennas, etc.
- Also avoid running the cable in parallel with power cables. When crossing with other cable, the angle should be 90° to minimize the magnetic field coupling.
- The signal cable run between the antenna and processor units should be unbroken; namely no splicing allowed.
- When connecting to analog signals (synchronous or step signals) of Gyrocompass, read Chapter 3.7 "Setting Gyrocompass signals) prior to wiring.

2.1 Interconnection

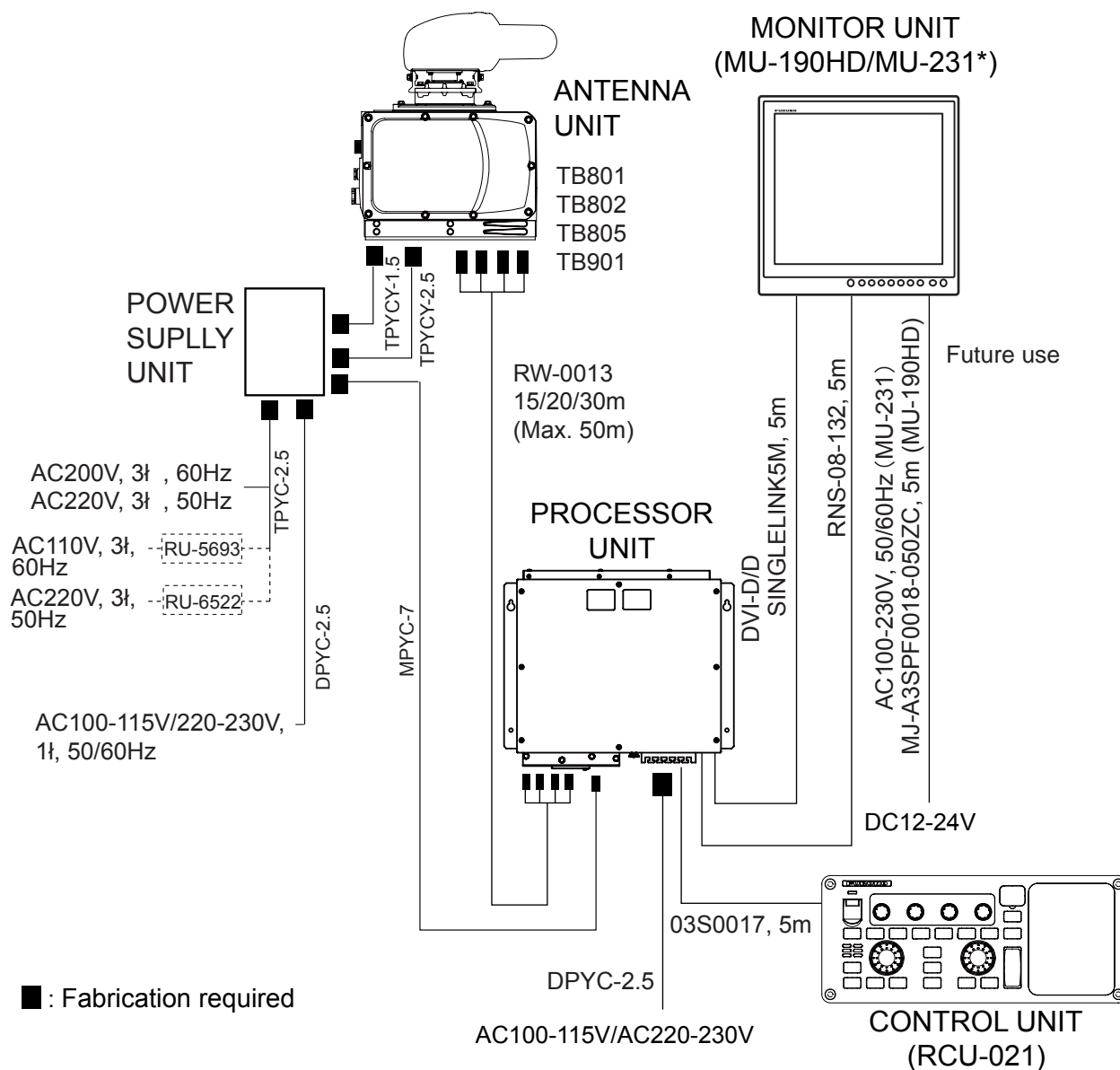

2.2 Antenna Unit

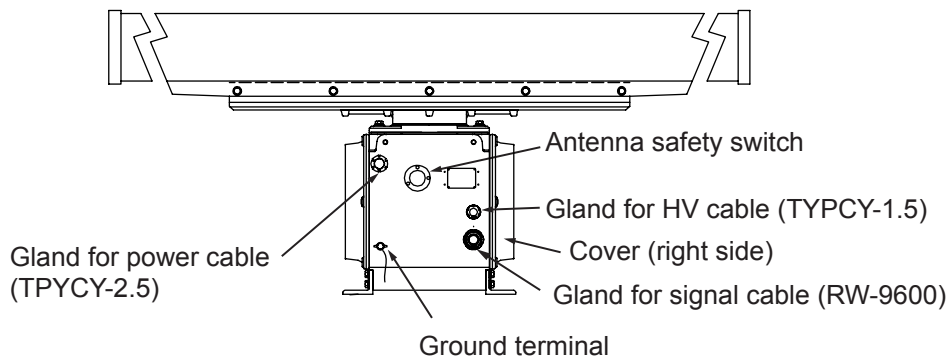

Antenna unit, front view

Fabricating signal cable RW-9600 and HV cable TYP CY-1.5

- Use a ratchet or box wrench (diagonal 13 mm) to open port- and starboard-side covers on the antenna unit.
- Unfasten the gland nut for the signal cable and remove the gasket, flat washers (3 pcs.) and gland cap. (The gland cap may be discarded.)
- Fabricate the signal cable RW0-013 as shown below.
 - Remove the outer vinyl sheath by about 320mm.
 - Unravel the exterior shield to expose the core wires.
 - Similarly, unravel the interior shield to expose the core wires.
 - Combine the exterior and interior shields and attach crimp-on lug (FV5.5-4 yellow, □4) at the end of the shields.
 - Trim each wire matching to the position of the terminal block. See the wiring diagram at the back of this manual.
 - Remove insulation of each wire by about 6mm. Fabricate the coaxial cable as shown in the diagram below.
- In the order shown in the figure below, pass the gland nut, flat washers (3 pcs.) and gasket onto the signal cable.

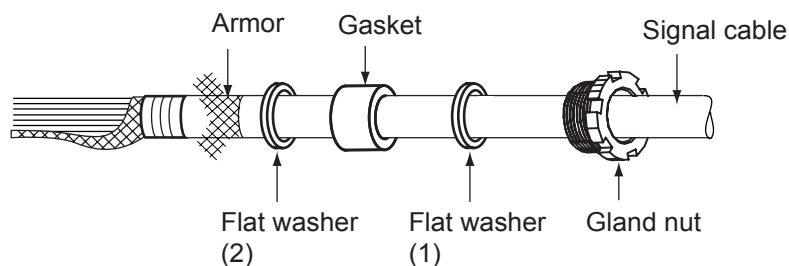
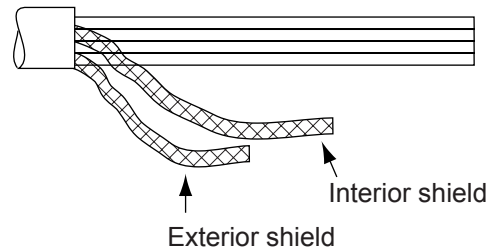
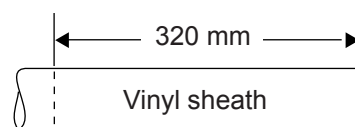

- As shown in the figure below, fold back the armor onto flat washer (2) and insert remaining armor through flat washer (3). Cut off the part of the armor that protrudes past the flat washers (2) and (3).

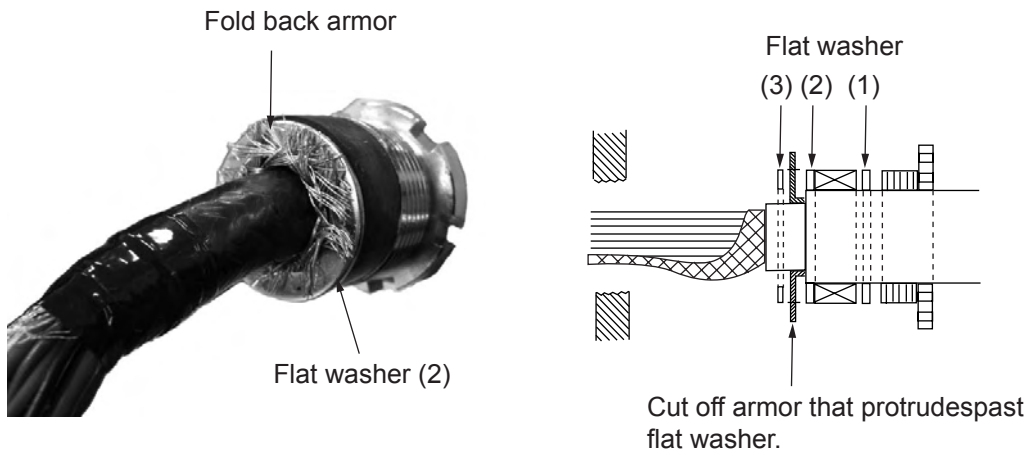

- Lead the signal cable through its cable gland and then into the chassis. Coat the threaded part of gland nut with sealant (supplied) and then tighten the nut.

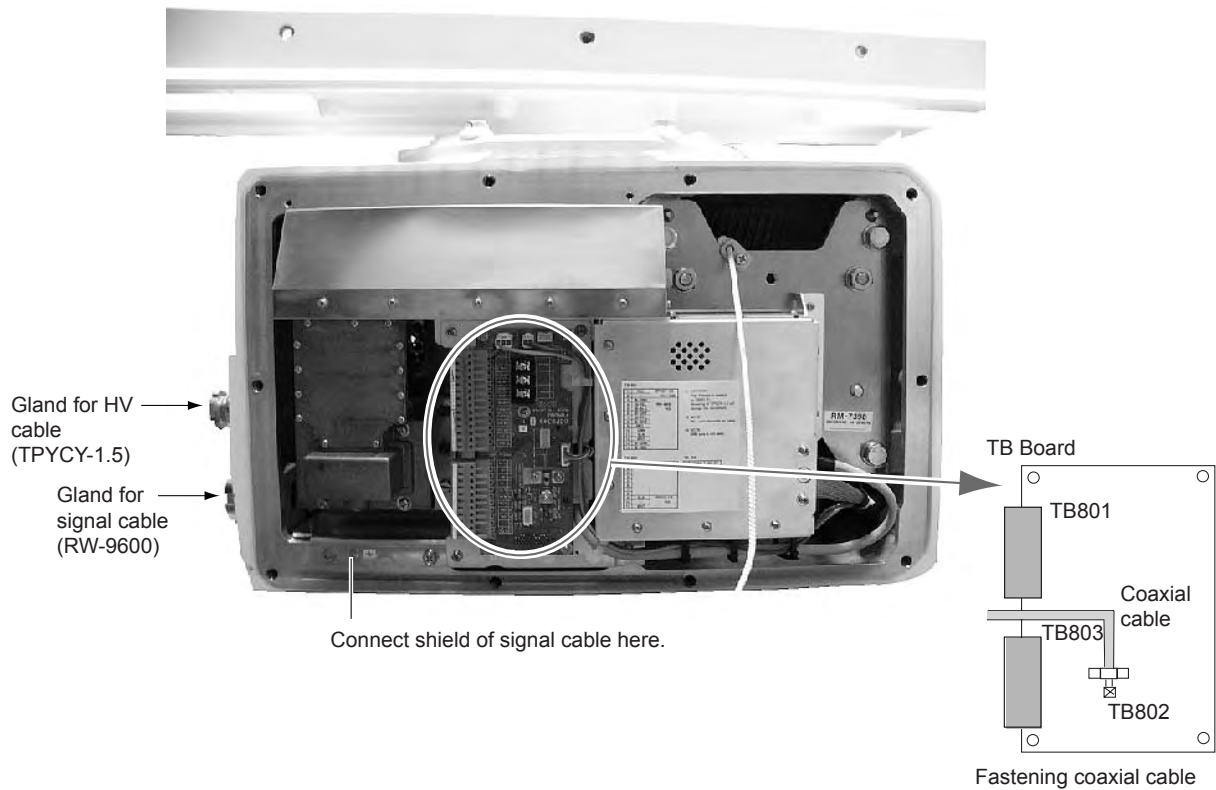

Antenna unit, front view

- Using the terminal opener provided, connect cores (except coaxial cable) to their appropriate locations on TB801 on the TB Board. Refer to the interconnection diagram for wiring details.

8. Connect the coaxial cable to TB802, referring to the right-hand illustration below..

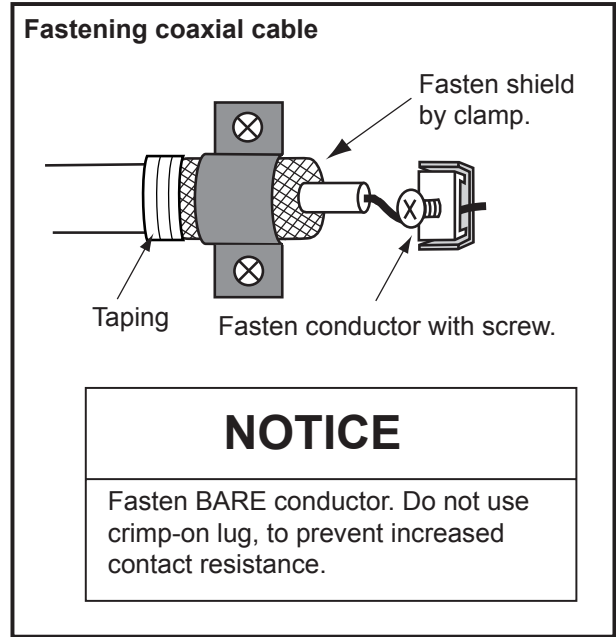
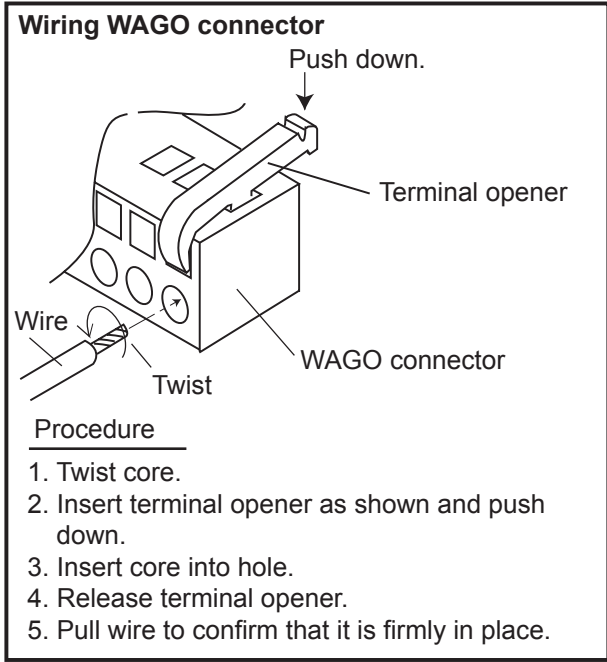

How to wire WAGO connector

9. Attach crimp-on lug (FV5.5-4) to the shield of the signal cable and fasten it with the screw at the location specified in the illustration on the preceding page.
10. Process unused cores as follows:
 - a) Slip shrink tubing onto cores and heat.
 - b) Bind unused cores with cable tie.
11. Unfasten the gland nut for the HV cable and remove gasket, flat washers (3 pcs.) and gland cap. (The gland cap may be discarded.)
12. Fabricate the HV cable as shown below.

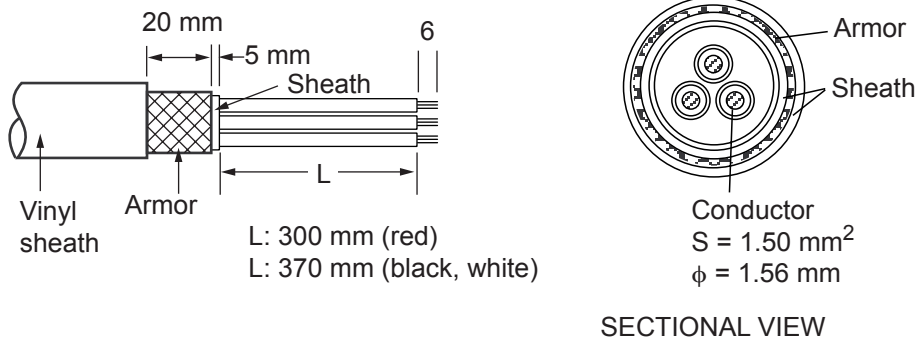

How to fabricate HV cable TYPCY-1.5

13. In the order shown in the figure below, pass the gland nut, flat washers (3 pcs.) and gasket onto the HV cable.

- As shown in the figure below, fold back the armor onto the flat washer and insert it thru the other flat washer. Cut off the part of the armor that protrudes past the washer.

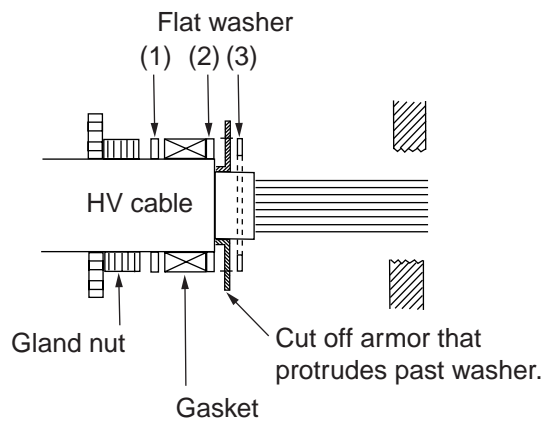

- Pass the HV cable through its cable gland and tighten gland nut.
- Using the terminal opener, connect wiring to TB901, referring to the interconnection diagram.

⚠ CAUTION

High voltage is present at the No. 1 pin of TB801. Miswiring at this pin can damage the antenna unit.

- Close the cover.
- Seal the cable gland for the HV cable with putty.

Fabricating the power cable TYP CY-2.5

- Use a ratchet or box wrench to open the port-side cover on the antenna unit.
- Unfasten the gland nut for the signal cable and remove the gasket, flat washers (3 pcs.) and gland cap. (The gland cap may be discarded.)
- Fabricate the power cable as shown below. Unravel the armor. Wrap sheath with vinyl tape to fix base of vinyl wire.

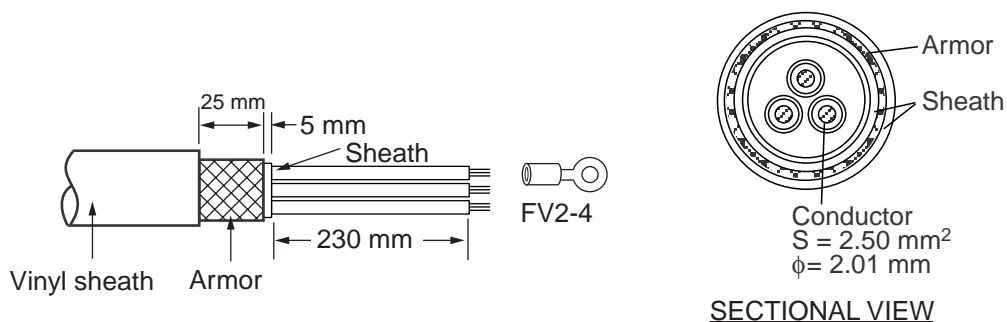

How to fabricate power cable TYP CY-2.5

- In the order shown in the figure below, pass the gland nut, flat washers (3 pcs.) and gasket onto the power cable.

- As shown in the figure below, fold back armor onto flat washer and insert it thru the other flat washer. Cut off part of armor that protrudes past flat washer.

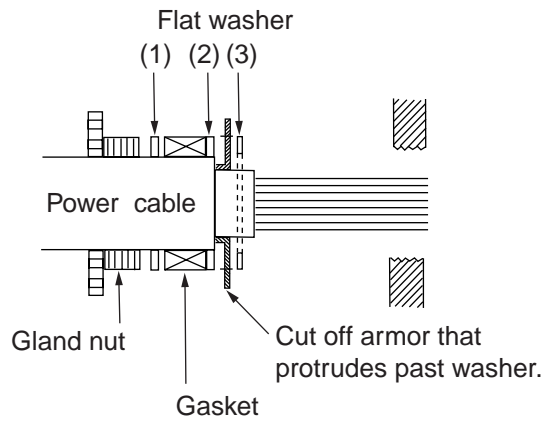

Passing flat washer, etc. onto HV cable

- Pass the power cable through its cable gland and then tighten the gland nut.
- Pass the power cable to the rear of the antenna unit.

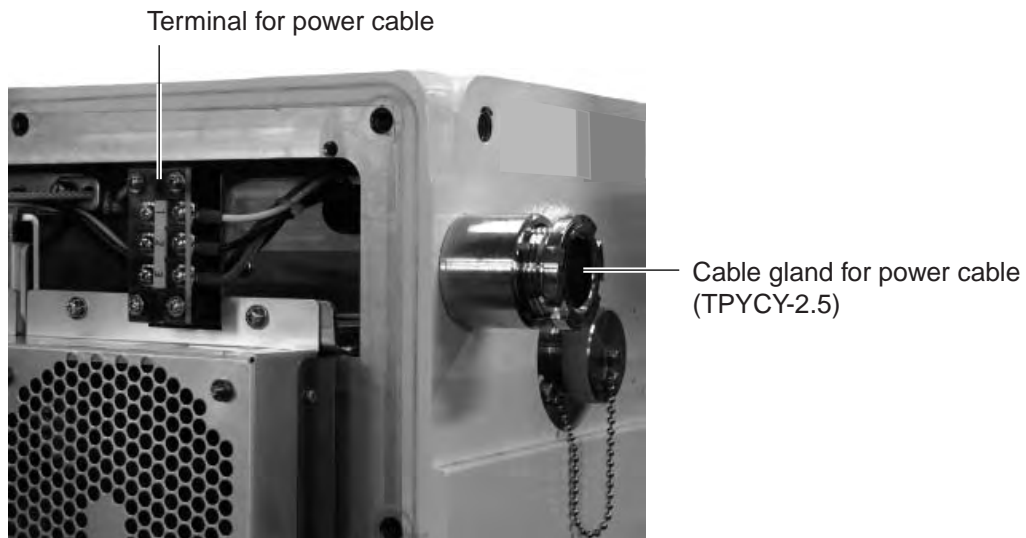

Antenna unit, left-side view

- Connect the power cable to its terminal, referring to the interconnection diagram.
- Close the cover.
- Seal the cable gland for the power cable with putty.

2.3 Processor Unit

Six cables are terminated at the processor unit in the basic structure; the antenna unit cable, two display unit cables, power supply unit cable, control unit cable and the power supply cable. Cables other than the power cable are connected to the processor unit with a connector. Fabricate the power supply cable (DPYC-2.5) as below. Connect LAN cable (50cm) supplied between the ports NETOWRK1 and NETWORK2 of the processor unit for installation of a single unit. (See page 2-8)

Note: Pass the AC power supply line through a double-contact breaker (shipyard supply) to connect to this unit.

Fabricating the power cable

1. Cut armor of the cable by 40mm.
2. Cut vinyl sheath by 35mm.
3. Remove insulation of the core wire by about 10mm. Fix crimp-on lugs (FV5.5-4, yellow supplied) to the cores.
4. Peel paint of the armor by 40mm for making grounding connection.
5. Cover the end of armor with vinyl tape. Put the section where paint was peeled through the cable cramp on the rear panel of the processor unit and fasten it.
6. Fasten the crimp-on lugs on the terminal block.

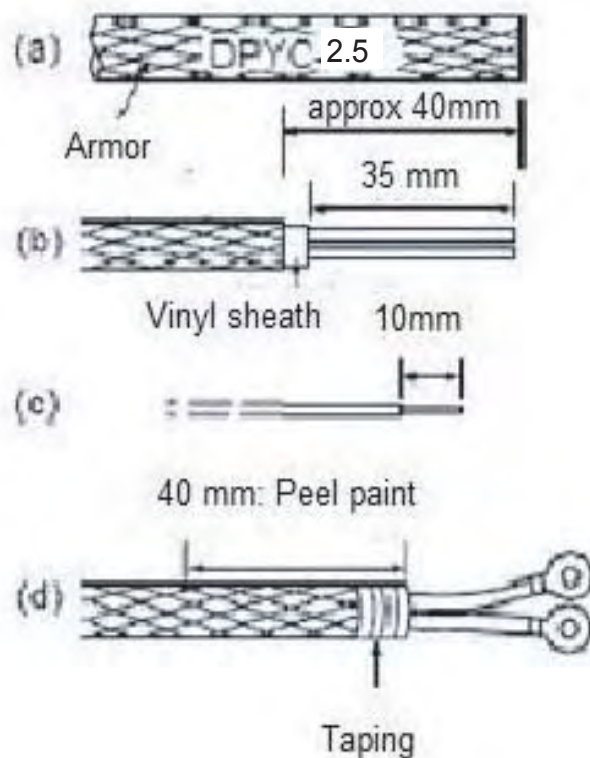

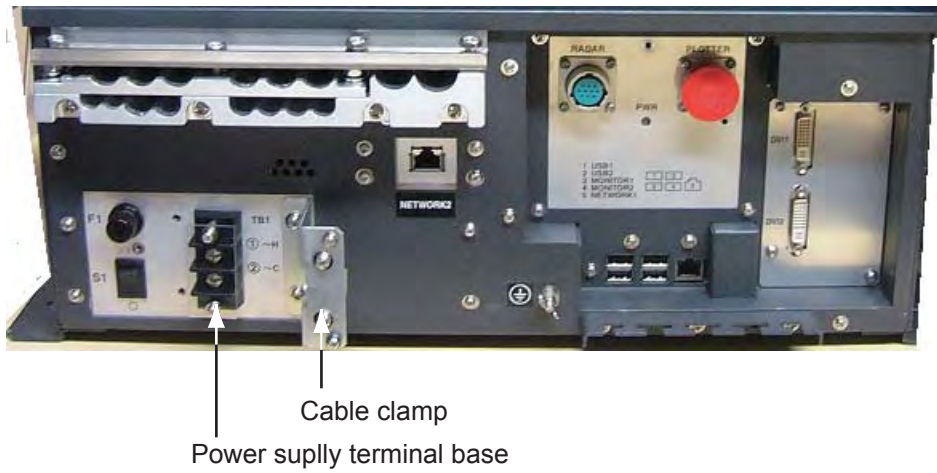

Connecting cables to the rear panel of the processor unit

Cables between control units and cables between monitor units are connected to ports on the rear panel of the processor unit. Connect LAN cables of the installation material as shown below.

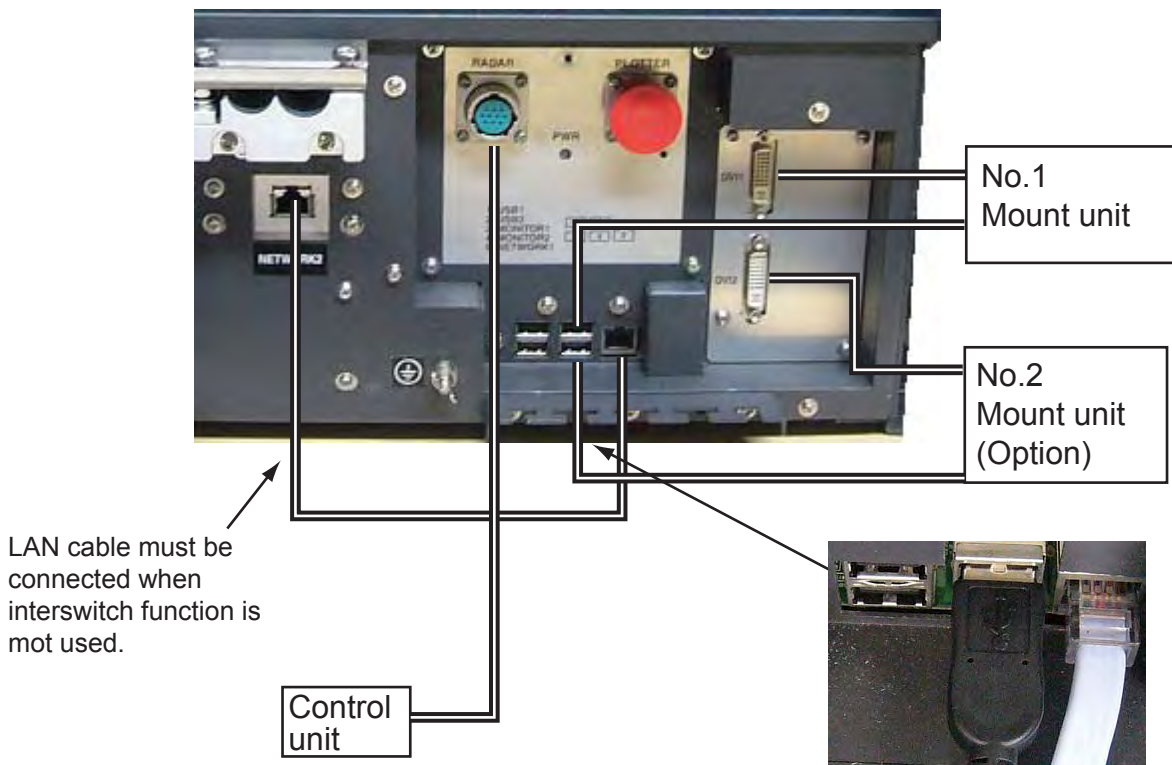

Fix USB cable to the metal fixture with binding ties.

- Note 1) Monitor unit 1 and 2 must have the same resolution.
- Note 2) USB ports USB1 and USB2 are not used.
- Note 3) Nothing will be displayed on the monitor units are not connected before the power is turned ON.

Connecting cables inside of the processor unit

Connect cables from the antenna unit, power supply unit and optional equipment are connected to the TB board (03P9491) etc. inside of the processor unit. Open the cover of the processor unit to find the TB board.

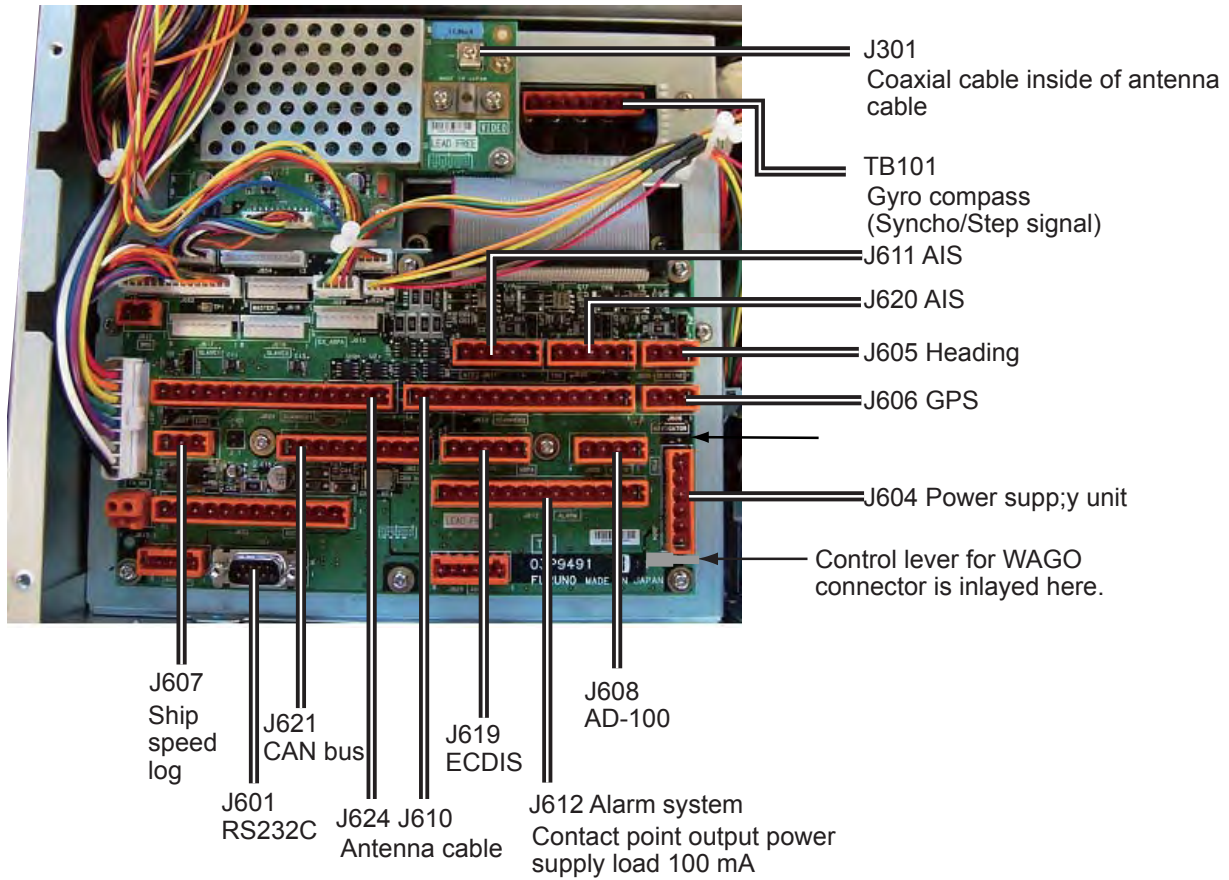

Cable fabrication for cables connected to the TB board (03P9491)

See the wiring diagram below for connecting the core cable.

Signal cable RW-0013

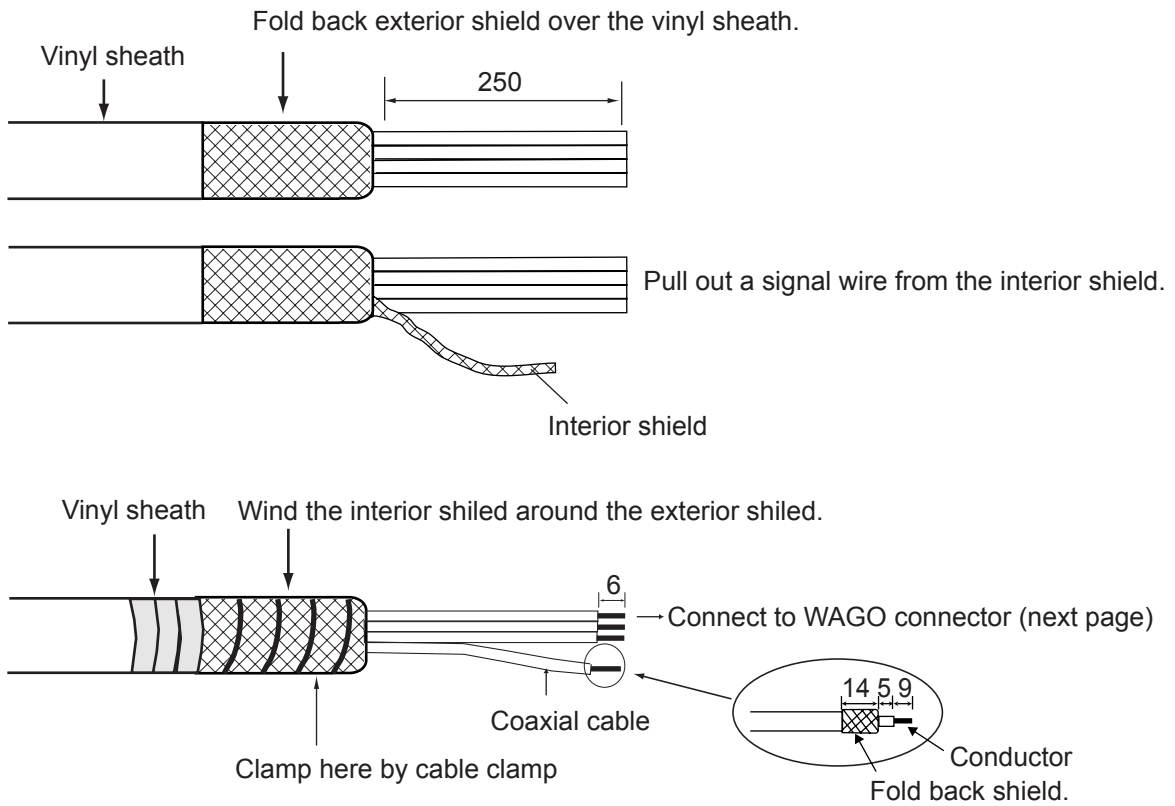

Optional cable: TTYCS-1/TTYCS-4/TTYCS-7/TTYCS-1T

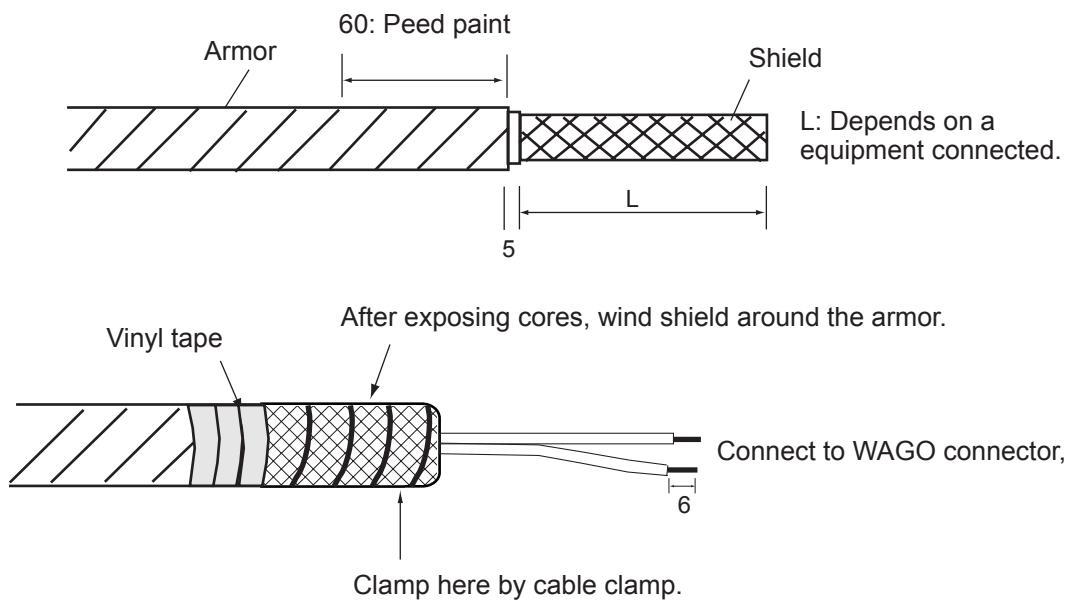

Wiring WAGO connector

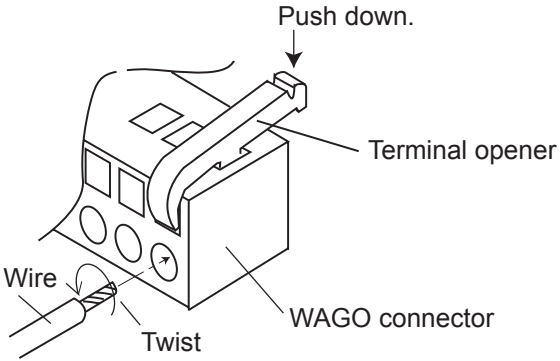

Procedure

1. Twist core.
2. Insert terminal opener as shown and push down.
3. Insert core into hole.
4. Release terminal opener.
5. Pull wire to confirm that it is firmly in place.

Fastening coaxial cable

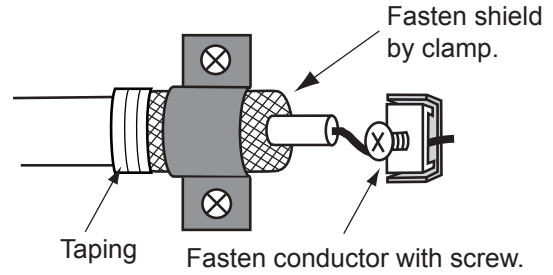

NOTICE

Fasten BARE conductor. Do not use crimp-on lug, to prevent increased contact resistance.

Connection for main radar, sub-radar and track target displays

To use the equipment as main radar and connect to a sub-radar, connect to J617 (SLAVE1) or J618 (SLAVE2) using the optional cable RW-4864. Up to two sub-radars can be connected.

To use the equipment as sub-radar and connect to a main radar, connect to J616 (MASTER) using RW-4864.

To connect the equipment to a track target display unit, connect to J615 using RW-4864.

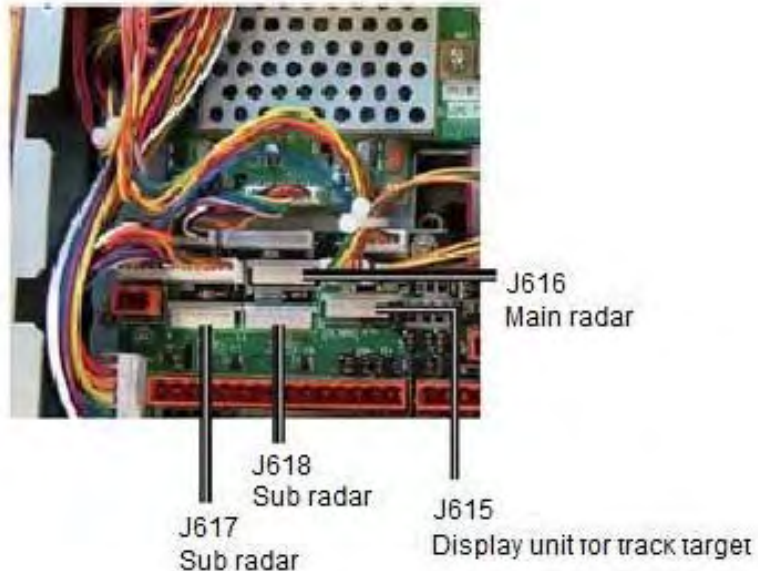

2.4 Power Supply Unit

Wire the power supply unit referring to the interconnection diagram. Be sure to ground the unit, with IV-8sq wire (local supply).

Note 1: Motor specification cannot be changed in the field.

Note 2: Pass the AC line through a double-contact breaker (shipyard supply). Further, for vessels where the power line is grounded, connect one end of the line to the C (common) terminal and the other end to the H terminal.

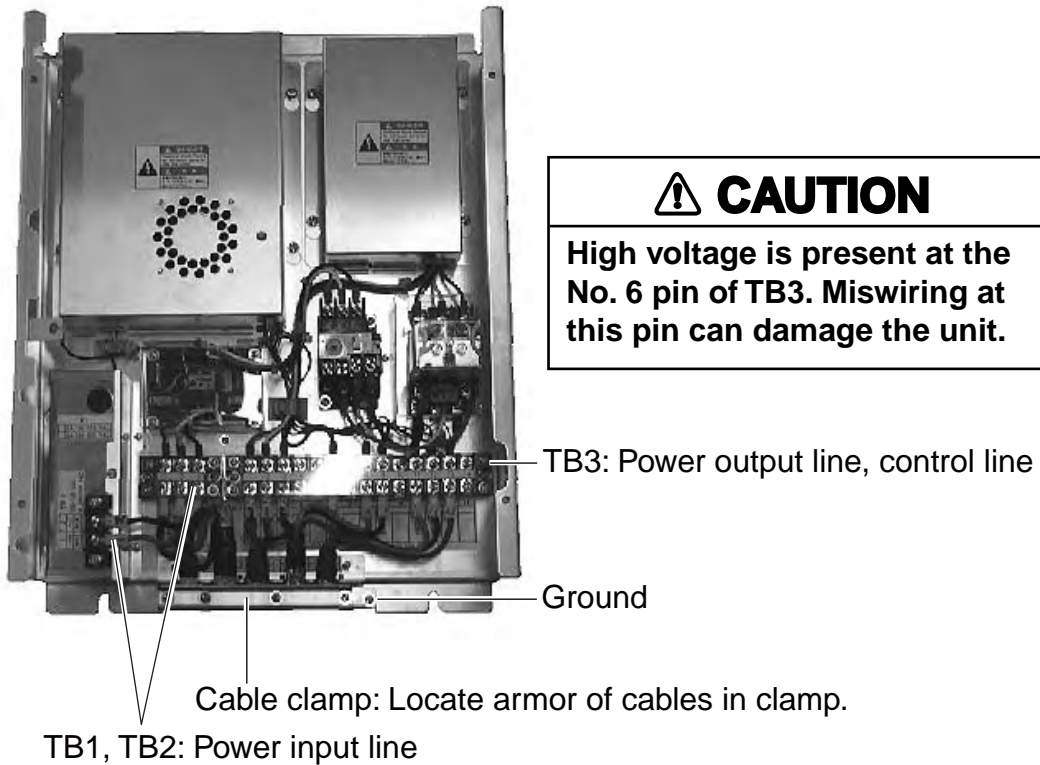

Power supply unit, inside view

Fabricating cable connected to terminal TB1, TB2, TB3

Terminal TB1: cable DPYC-2.5

See page 2-8 for sectional view of cable if using equivalent cable.

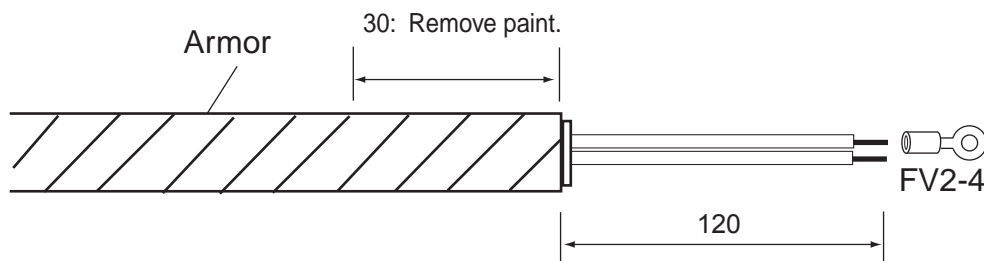

Terminal TB2: cable TPYC-2.5 (for antenna motor)

Terminal TB3: #11-#13, cable TYPC-1.5 (between power control section and processor)

See page 2-5 for sectional views of these cables if using equivalent cables.

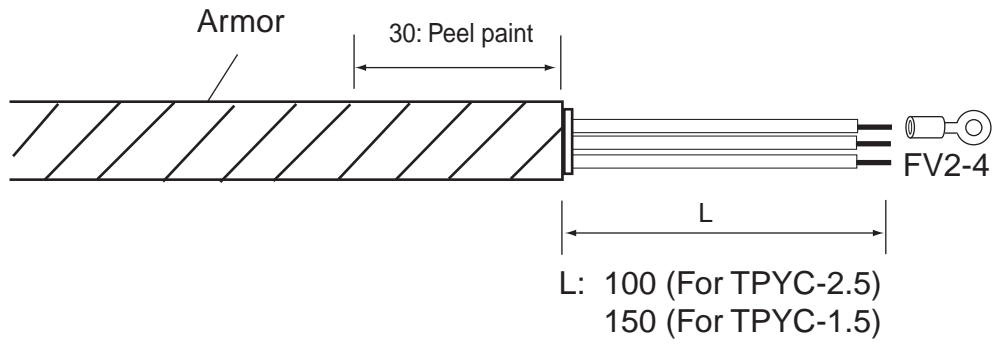

Terminal TB3: #1-#3 TPYCY-2.5 (between power control section and antenna)
Terminal TB3: #6, #8, #9 TPYCY-1.5 (between power control section and antenna)

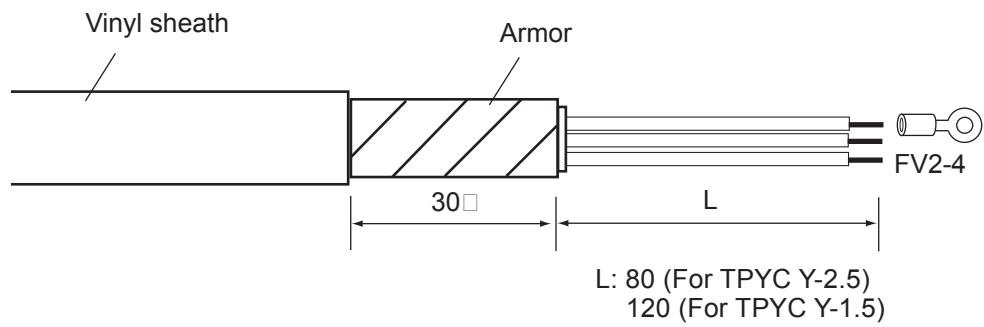

$\phi =$ TYPYC Y-1.5: 14.5 mm
TYPYC Y-2.5: 15.5 mm

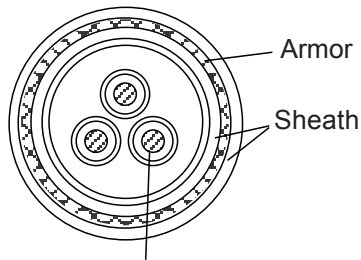

S = TYPYC Y-1.5 : 1.5²mm, TYPYC Y-2.5 : 2.5²mm
 $\phi =$ TYPYC Y-1.5 : 1.56mm, TYPYC Y-2.5 : 2.01mm

2.5 Changing AC Power Specification of Processor Unit

To change AC power specification from AC100V to AC220V or vice versa, change the fuse and add or remove jumper connector on the processor unit and power supply unit.

2.5.1 Processor Unit

Refer to the table and figures below to make changes. Adjust the overvoltage detection circuit after the change. (a variable auto transformer is required.)

Note: To change from AC220V to AC100V, locally prepare the jumper connector, referring to the figure shown below. (VH6P connector housing is fitted in J111.)

Power Supply	Fuse	Jumper connector P111
AC100V	7A	Necessary (between 1-2, 4-6)
AC220V	3A	Not necessary (no jumper wire needed.)

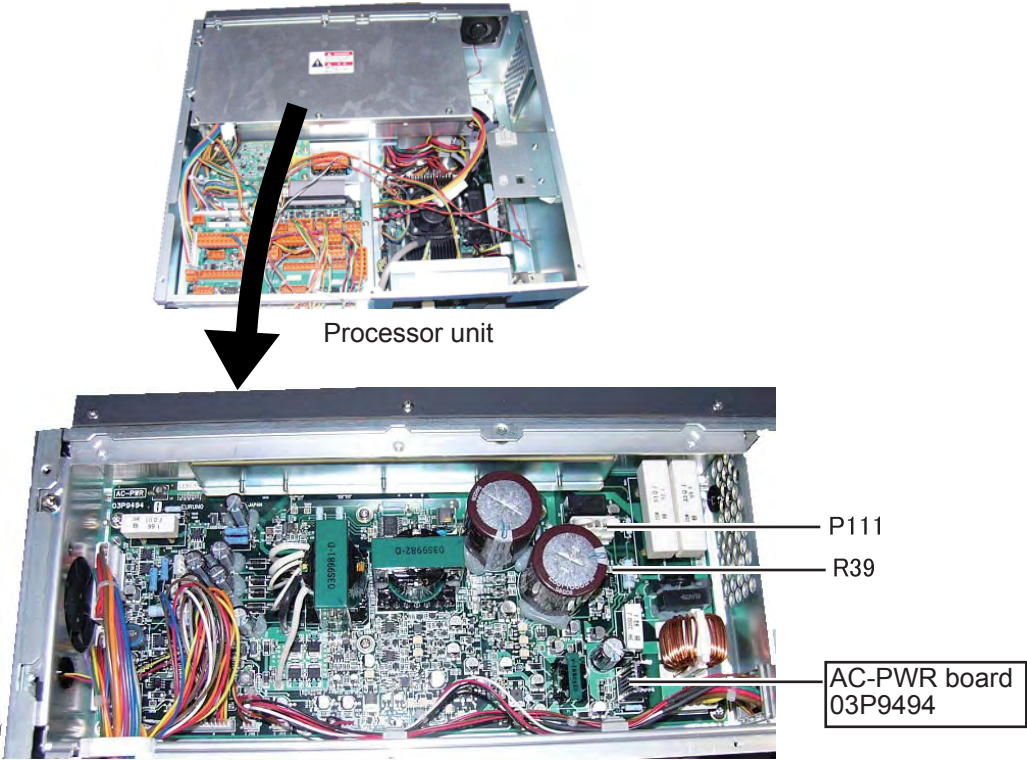

Processor unit (Cover is removed)



Jumper wire for AC100 V between 1-2, 1-6 short-circuit

How to adjust the overvoltage detection circuit:

1. Add or remove the jumper connector P111 and change the fuse.
2. Rotate R39 fully counterclockwise on the AC-PWR board.
3. Connect a variable transformer between ship's mains and the input power terminal board TB-1 of the processor unit.
4. Adjust the variable transformer output (i.e. input voltage to the processor unit) as follows.
 - For AC100V specification: AC156V
 - For AC220V specification: AC301V
5. Turn on the processor unit and rotate the R39 clockwise gradually until the overvoltage detection circuit functions and the power supply cuts off.
6. Lower the output voltage of the variable transformer and confirm that the radar automatically turns on with a voltage lower than AC155V or AC297V.
7. Gradually increase the output voltage of the variable transformer and confirm that the overvoltage detection circuit functions at AC 156V or AC301V and the power supply is cut off.
8. Assemble and connect the processor unit correctly.

2.5.2 Power Supply Unit

Refer to the illustration and table below to add (or remove) jumper connector P8 from the TX-HV Board (03P9350) and change fuse.

After completing jumper and fuse arrangements, adjust the overvoltage detection circuit, using a variable transformer.

Note: When switching from 220 VAC to 100 VAC, construct a jumper connector locally, referring to the illustration below. (VH6 connector housing is to be plugged into J8.)

Power Supply	Fuse	Jumper connector P8
AC100V	5A	Required
AC220V	3A	Unnecessary

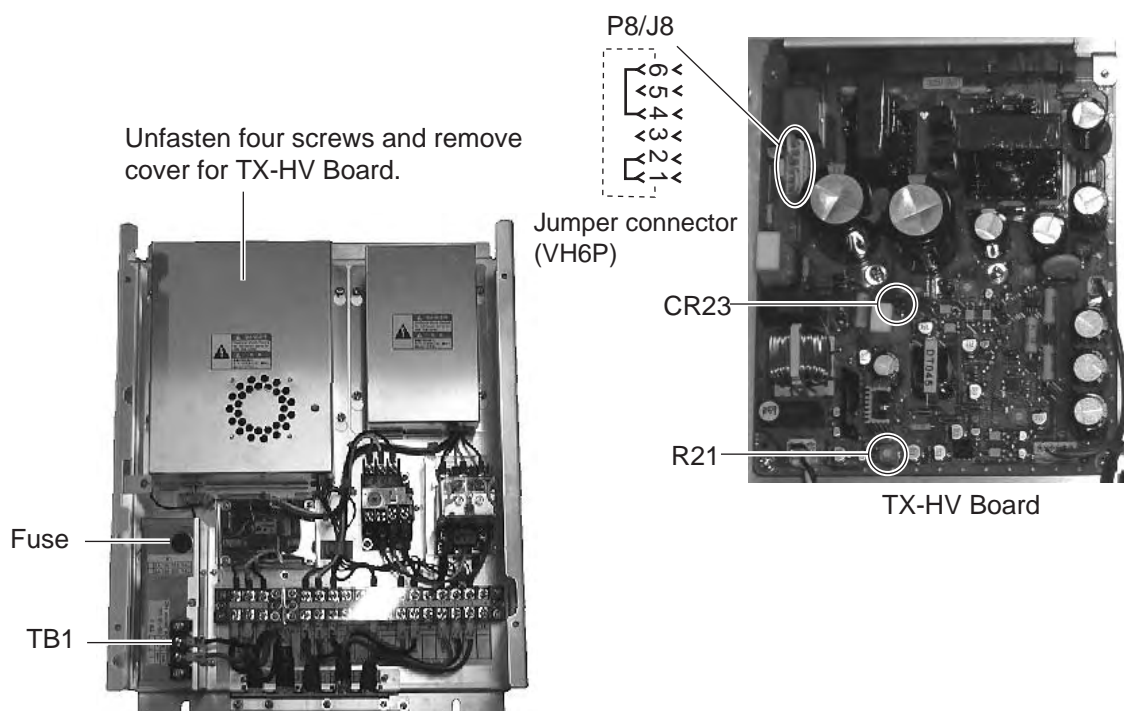

How to adjust the overvoltage detection circuit:

1. Add or remove the jumper connector P8 as appropriate and change the fuse, referring to the table above for details.
2. On the PWR board, set R21 fully clockwise.
3. Connect a variable transformer between ship's mains and the input power terminal board TB-1 in the processor unit.
4. Adjust the variable transformer output (i.e., input voltage to the processor unit) as follows:
For 100 VAC set: 144 VAC
For 220 VAC set: 288 VAC
5. Turn on the radar and rotate R21 counterclockwise gradually until the overvoltage detection circuit activates (i.e., power supply cuts off).
6. Lower the output voltage of the variable transformer and confirm that the radar automatically turns on with a voltage lower than 142 VAC or 284 VAC.
7. Gradually increase the output voltage of the variable transformer and confirm that the overvoltage detection circuit activates at 144 V or 288 VAC of the variable transformer output.
8. Assemble and connect the power supply unit.

2.6 Interswitch

Switching hub HUB-100 (optional) is necessary to switch between two processor units. Four LAN cables are necessary. The following diagram shows the connection between the processor units.

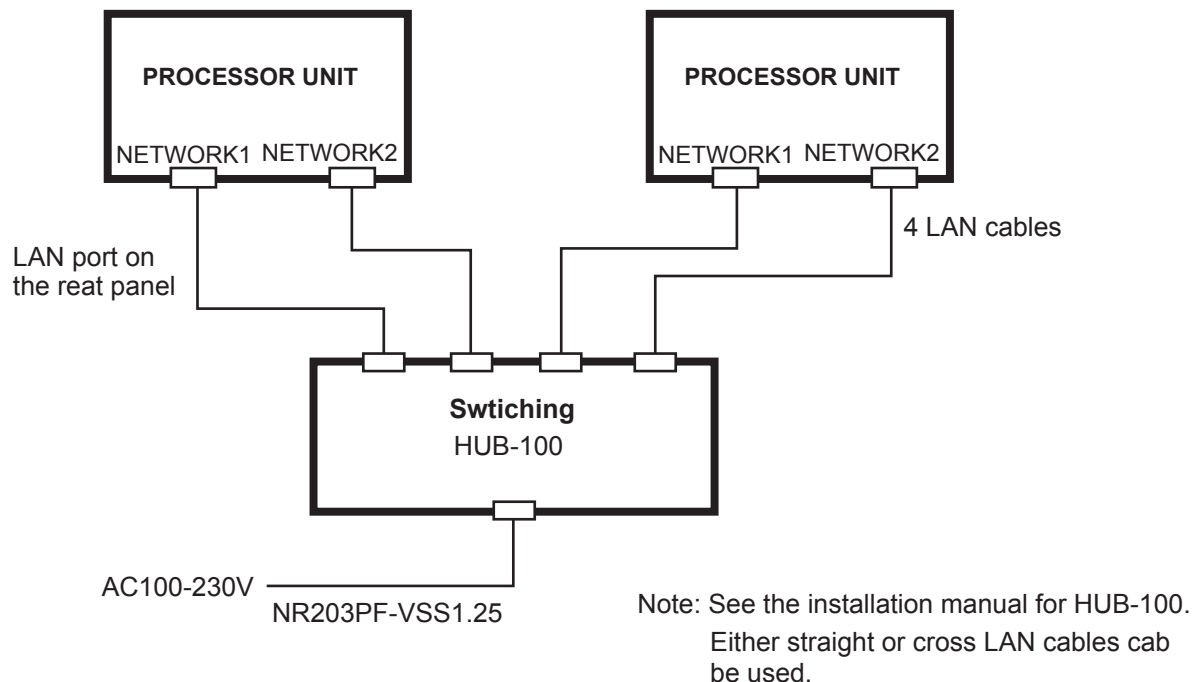

2.7 Connection to CAN bus Network

When connecting to CAN bus network through J621 (CAN bus port) of the processor unit, a terminator may need to be connected. See the diagram below. For details of CAN bus network, refer to "FURUNO can bus Network Design Guide" published by FURUNO for service technicians.

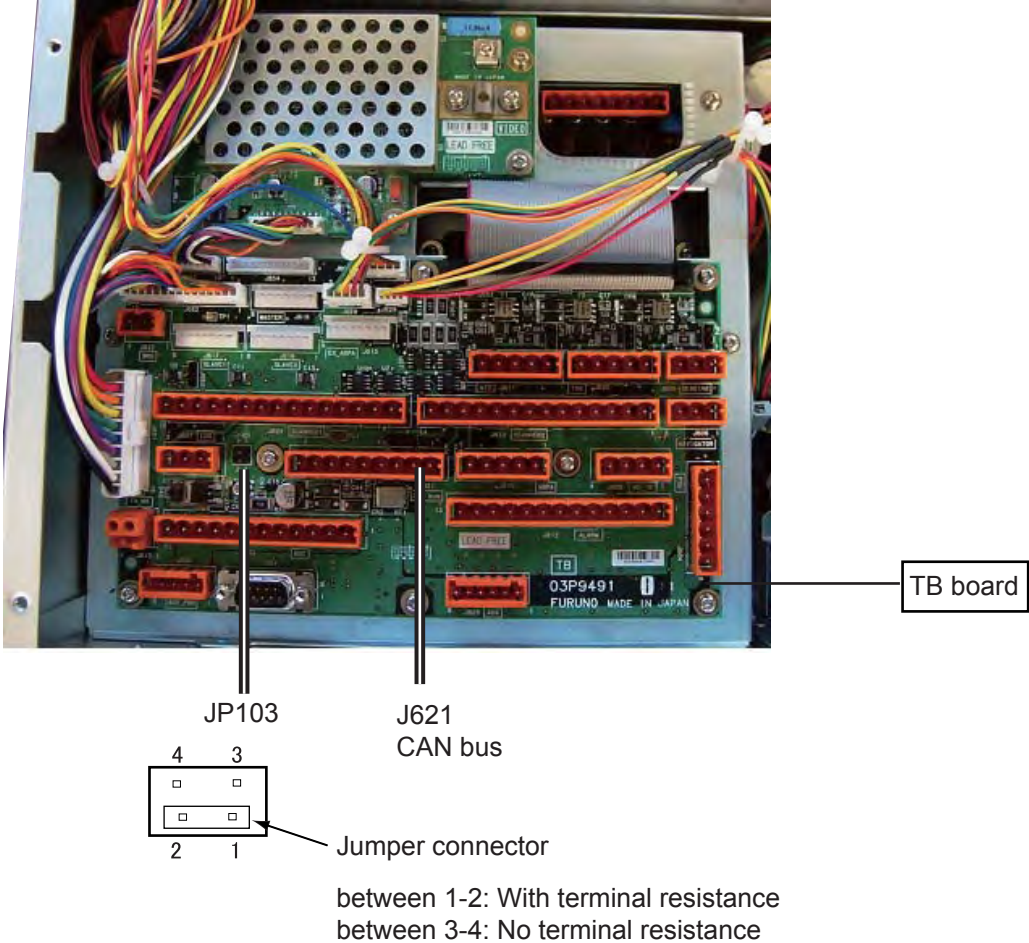

3. SETTING AND ADJUSTMENT

This chapter contains sections 3.1 through 3.7. Please set the equipment in the order of the sections.

Note 1: The processor unit with AC specification has a power supply switch at the rear panel. Keep the switch ON at all times.

Note 2: Every unit has the same IP address set as the factory default. Therefore when connecting the unit by inter-switching, turn on the power for each unit to set IP address. (See pages 3-2 and 3-3). After setting IP address for all units, set “Common 1/Own ship’s information” on page 3-3 while power is turned on for each unit.

3.1 Setting Initial Setting Wizard

After installing equipment and wiring, turn on the power and initialize the system according to the initialization wizard.

1. Press the power switch [] on in the operation unit.
2. Press the [Delete heading line] key and immediately press [Delete target] key five times. SYSTEM SETUP MENU appears.



3. Select “Initialization Wizard” and click the left button. Initialization wizard appears after a few seconds.
4. Do the setting on the first page and then press the [Next page] button.
5. After setting necessary items, go to the next page using the [Next page].
6. After all the settings are done, press the [Save settings/Finish] button. The system restarts automatically and “Preparing” is displayed. Settings in each wizard page are explained in the following pages.

UIP (User Interface Processor) page

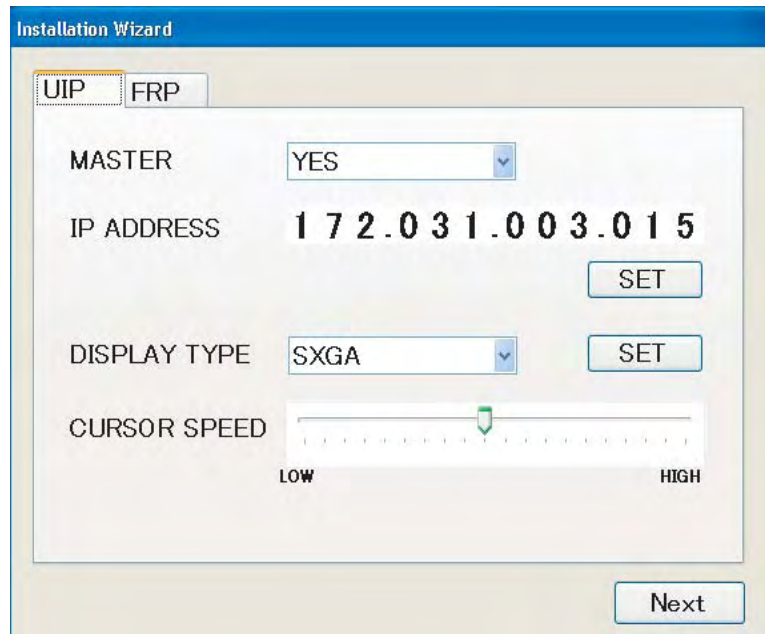

The screenshot shows the 'Installation Wizard' window with the 'UIP' tab selected. The window contains the following settings:

- MASTER:** YES (dropdown menu)
- IP ADDRESS:** 1 7 2 . 0 3 1 . 0 0 3 . 0 1 5 (with individual 'SET' buttons for each digit)
- DISPLAY TYPE:** SXGA (dropdown menu) with a 'SET' button
- CURSOR SPEED:** A slider control ranging from LOW to HIGH, with a green indicator in the middle.

A 'Next' button is located at the bottom right of the window.

Server: It means the chart server and normally YES remains as it is.

IP address: Set IP address of the processor unit UIP. For single installation, no change is necessary. IP address needs to be changed for inter-switch connection (2-13 page). Change only “xxx” parts of 172.031.003.xxx. xxx is an arbitrary number from 020 to 253. Set IP address that is different from other IP addresses.

Note: Do not set the same IP address on UIP and FRP pages.

How to input numbers: Put the cursor on numbers and the background of the number changes to green. Rotate the wheel or right click/left click to change the number. Press the [Set] button. Pop-up menu appears to restart the system. Press [Yes] to restart the system after about 30 second to 1 min. After the restart, repeat the process.

Screen size: When the display unit is MU-231, select [XGA] and the monitor unit is MU-190HD, select [SXGA] then press the [Set] button.

Cursor speed: Adjust the speed of cursor on the screen when moving the cursor with the trackball. Adjust the cursor speed in accordance with user’s convenience.

FRP (Radar Processor) page

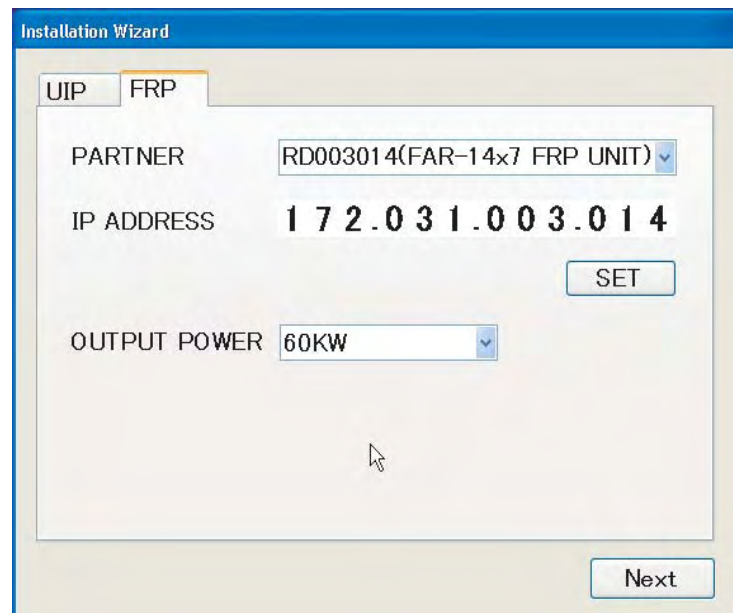

Partner: Set FRP which is paired with UIP. (See the next diagram.) It is set when two sets of FAR-14x7 series radars are connected through the switching hub. Normally, the factory default (FRP inside of the same processor unit) remains unchanged.

IP address: Factory default is shown. In case of inter-switch connection, set a value different from other values and press the [Set] button. Restart begins and the above screen remains for about 30 seconds.

Output power: Select 60kW.

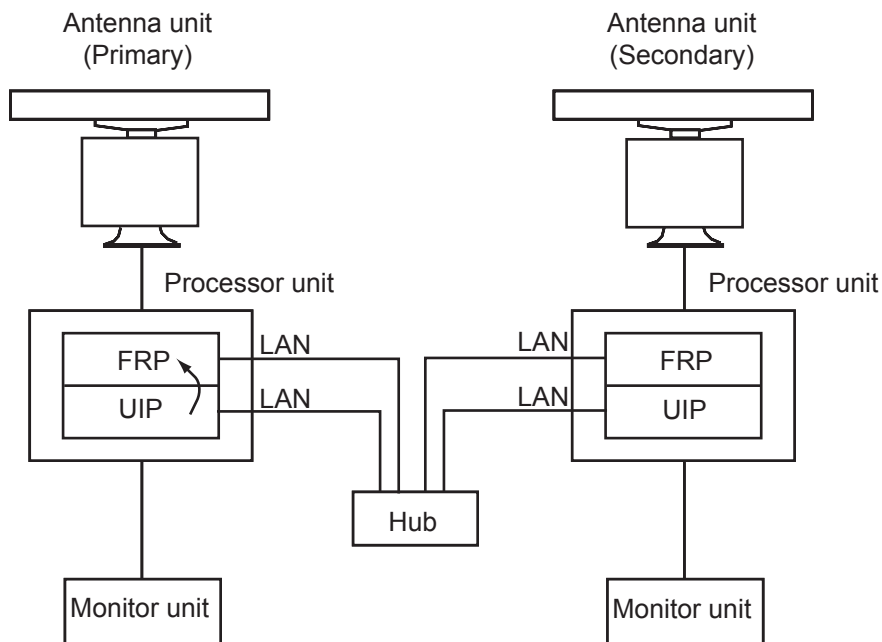

Common 1/Own Ship Data

The screenshot shows the 'Installation Wizard' window with the 'OWN SHIP INFORMATION' tab selected. The 'CONNECTION DIAGRAM' box contains the following list of units:

- FAR-14x7 UIP UNIT[MF003015]
- FAR-14x7 FRP UNIT[RD003014]
- AD_10
- NAVIGATOR
- ECDIS
- LOG(NMEA0183)
- HEADING
- AIS
- INS
- LOG(PULSE)
- AutoPilot Port
- Position Dead Reckoning
- SOG Reference
- STW Manual

Ship length: Input total length of ship. (tip of heading to end of stern)

Width of hull: Input width of hull

Steering position/Heading: Input distance from tip of ship to steering position.

Steering position/ Port (Starboard): Input distance from the center line of the ship to the steering position toward port or starboard.

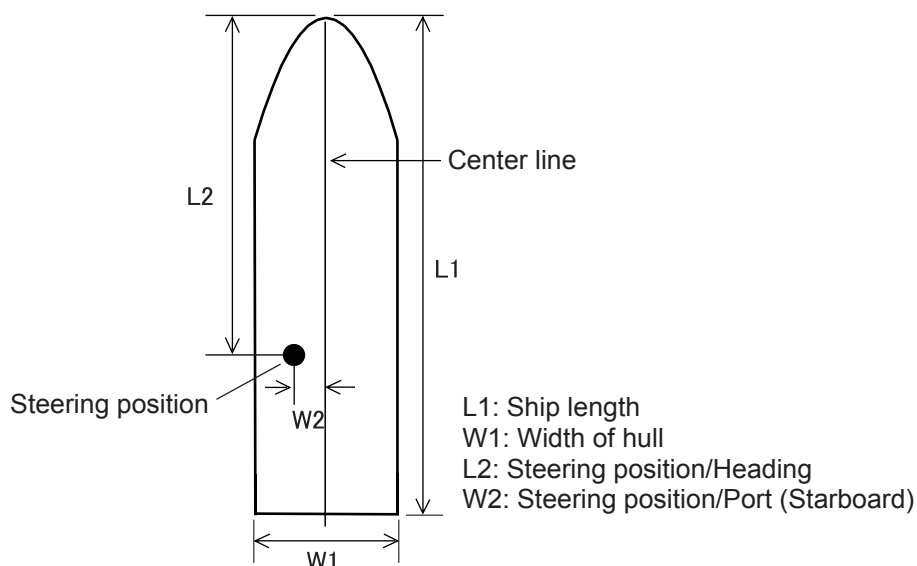

Unit Composition Box: When changing unit name displayed on the screen, select the name to be changed and press the [Change nickname] button. Input name from the keyboard displayed on the screen.



FRP/Installation Setting

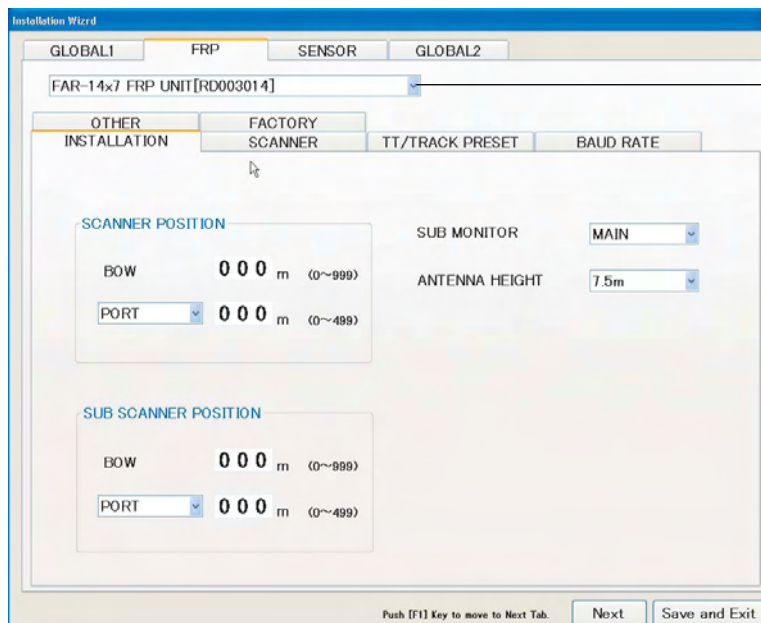

When interswitch is connected, set all FRP in the processor unit.

Position of antenna unit (primary), antenna unit (secondary)

- Heading: Input distance from the tip of the ship to the antenna unit.
- Port (Starboard): Set the position of antenna unit from the center line of the ship toward port or starboard direction.

Primary/Secondary: Set processor unit to function as primary radar or secondary radar.

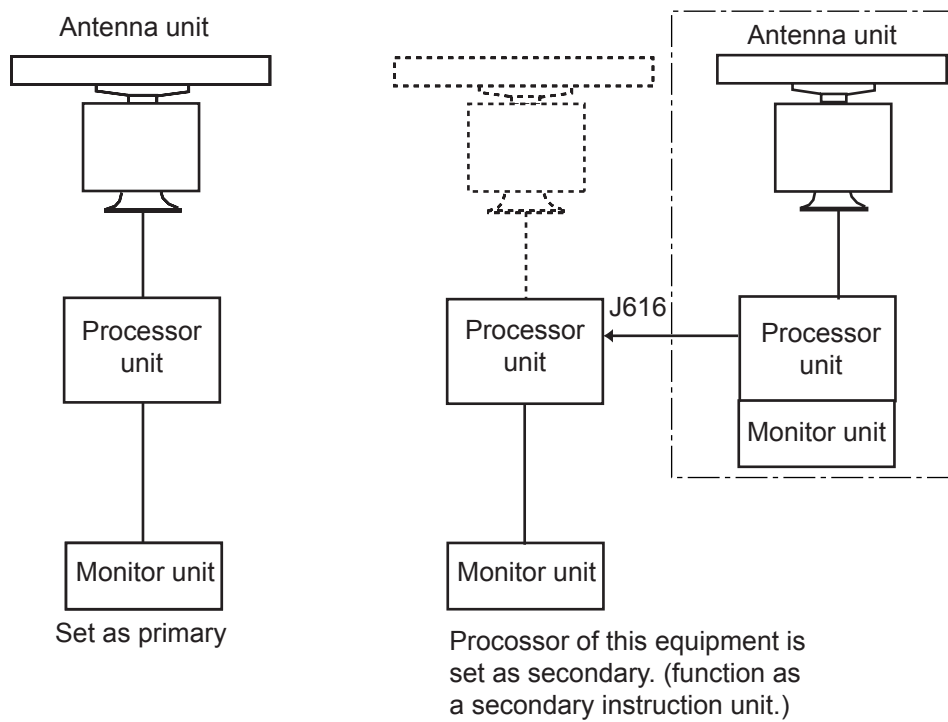

Antenna height: Set antenna height from the sea surface from 5/7.5/10/15/20/25/30/35/40/50m /50m.

FRP/Antenna Unit

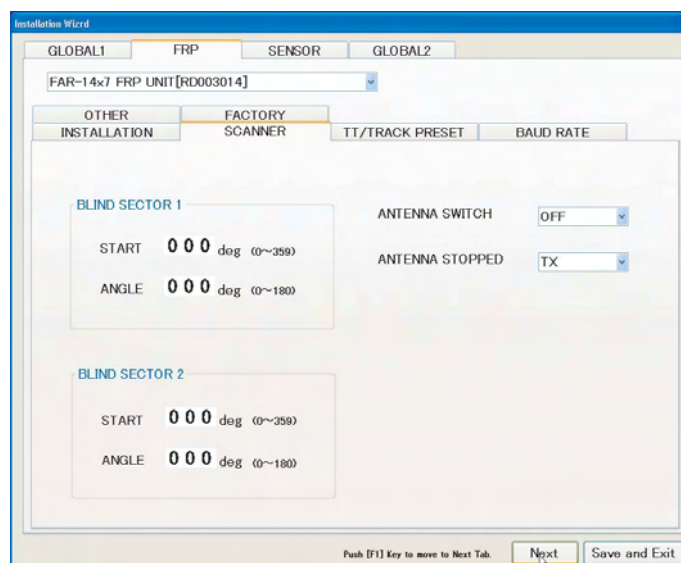

Transmission Stop Area 1, Transmission Stop Area 2: To secure safety of crew, set the two radar transmission stop areas in the start bearing (angle measured from the heading line) and in the setup angle (area to stop transmission). Two areas can be set.

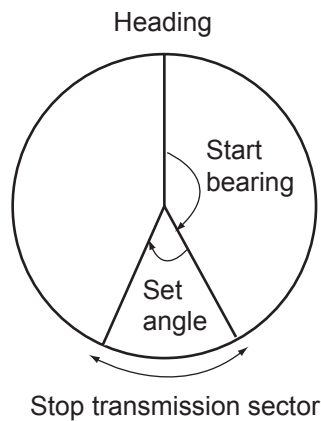

Antenna Rotation Switch: Set the switch by service technician when performing maintenance.

- OFF: Antenna does not rotate at preparation and transmission (at maintenance).
- ON: Antenna rotates at transmission (Normal setting).
- EXT: Do not use.

When antenna rotation is at stop: Set it at maintenance time by service technician.

- Preparation: When antenna stops during transmission, the transmission is at STAND-BY state.
- Transmission: Transmission continues when antenna stops during the transmission.

FRP/TT/Track PRESET

Set various parameters to be used in the target track function (TT: old name ARPA). Do not change default settings unless you are familiar with details of TT. The picture below shows default settings.

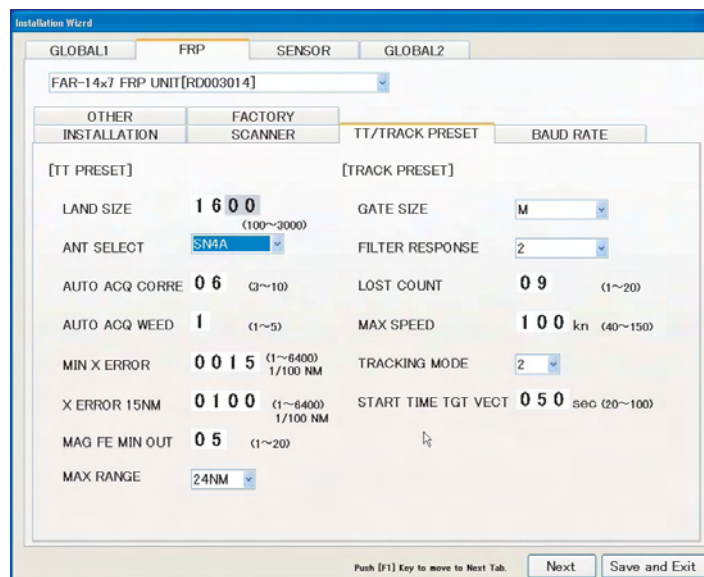

LAND SIZE: The minimum value determined to be land echo.

ANT SELECT: Type of antenna radiator used in the antenna unit.

AUTO ACQ CORRE: Update time of target that can be acquired automatically.

AUTO ACQ WEED: Time to the next automatic acquisition when there is some reserve of the automatic acquisition point.

MIN X ERROR: The minimum error between predicted target position and measured position to detect veering of target.

X ERROR 15NM: Threshold to detect veering of target which is over 15NM away.

MAG FE MIN OUT (Minimum echo width adjustment coefficient): The minimum echo width is detected from the ratio of antenna beam width. The minimum echo width to be detected can be adjusted by changing the ratio with this coefficient.

MAX RANGE: Select the maximum range of track target from 24NM or 32 NM. When 32 NM is selected, the repetition of transmission frequency of S1/S2 pulses becomes the 2nd trace.

Gate Size: Allowable error size between the predicted position of echo matching

Track filter: Responsiveness to changes of movements of target

Lost count: Number of scans until "lost" is determined

Maximum speed: Maximum speed of tracked target (not valid for this system)

Track mode: Track target mode

Vector Display Start: Time elapsed from acquisition of target until display of vector.

FRP/SIO baud rate

Set communication baud rate corresponding to the equipment connected to NMEA port inside of the processor unit. Set 4800 bps or 38400 bps depending on the communication speed of the other party.

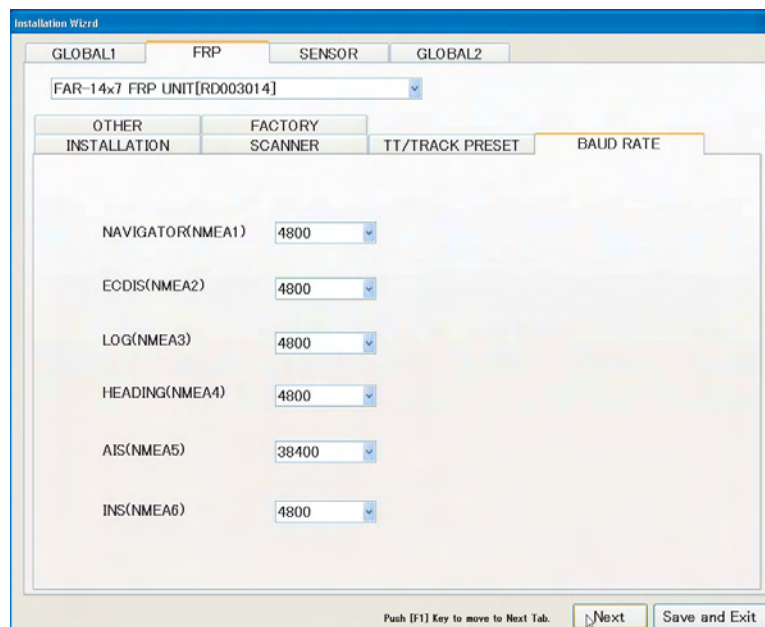

FRP/Others

Set signal type to display on radar screen. Normally set TRUE ECHO. Set EG for demonstration. Do not use TT TEST.

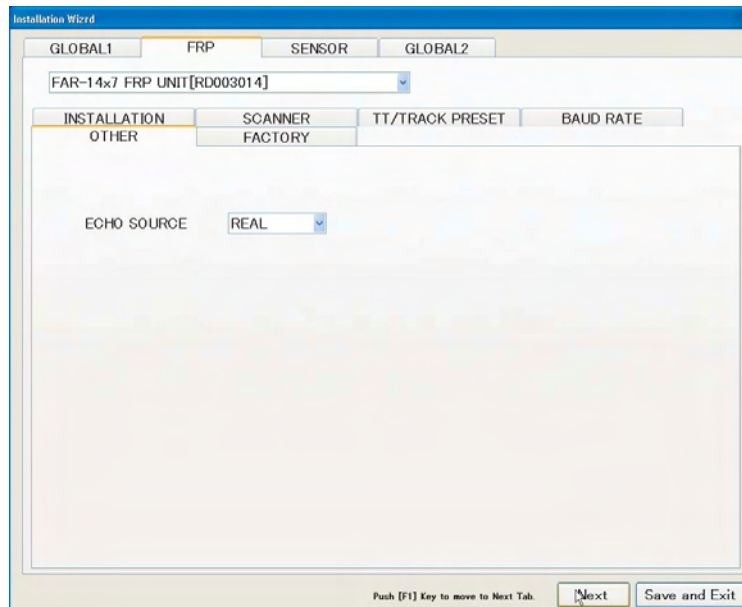

The screenshot shows the 'Installation Wizard' window with the 'FRP' tab selected. The window title is 'Installation Wizard'. At the top, there are four tabs: 'GLOBAL1', 'FRP', 'SENSOR', and 'GLOBAL2'. Below the tabs, there is a dropdown menu showing 'FAR-14x7 FRP UNIT [RD003014]'. Underneath, there are four sub-tabs: 'INSTALLATION', 'SCANNER', 'TT/TRACK PRESET', and 'BAUD RATE'. The 'INSTALLATION' sub-tab is active, and it contains two sub-sections: 'OTHER' and 'FACTORY'. The 'ECHO SOURCE' is set to 'REAL'. At the bottom of the window, there is a note 'Push [F1] Key to move to Next Tab.' and two buttons: 'Next' and 'Save and Exit'.

FRP/FACTORY

It is not necessary to setup this page at installation.

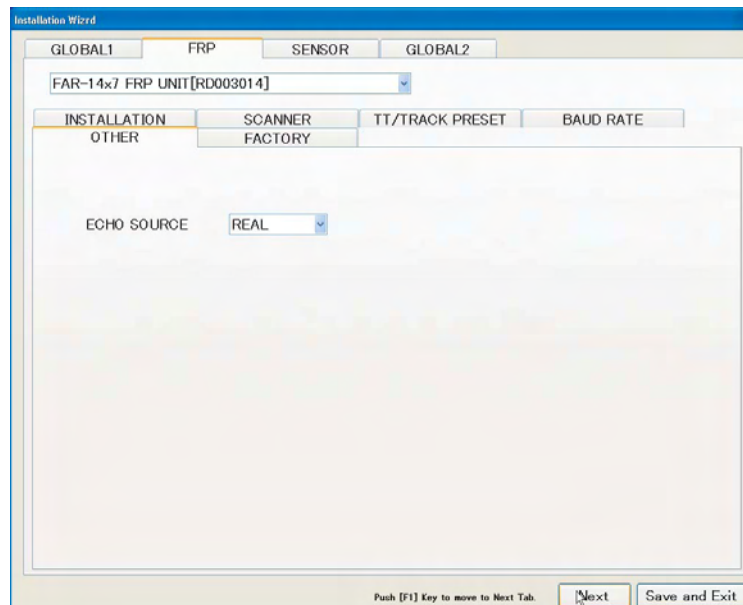

The screenshot shows the 'Installation Wizard' window with the 'FRP' tab selected. The window title is 'Installation Wizard'. At the top, there are four tabs: 'GLOBAL1', 'FRP', 'SENSOR', and 'GLOBAL2'. Below the tabs, there is a dropdown menu showing 'FAR-14x7 FRP UNIT [RD003014]'. Underneath, there are four sub-tabs: 'INSTALLATION', 'SCANNER', 'TT/TRACK PRESET', and 'BAUD RATE'. The 'SCANNER' sub-tab is active, and it contains two sub-sections: 'OTHER' and 'FACTORY'. The 'ECHO SOURCE' is set to 'REAL'. At the bottom of the window, there is a note 'Push [F1] Key to move to Next Tab.' and two buttons: 'Next' and 'Save and Exit'.

Sensor/AIS

It is not necessary to setup parameters in this page at installation.

Sensor/GPS

Set parameters related to GPS navigation equipment connected.

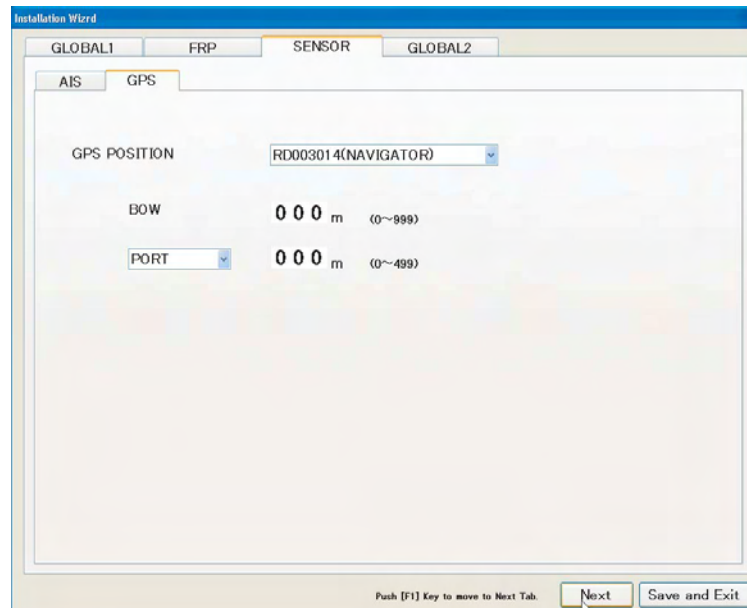

Position of GPS antenna: When reading data from multiple GPS's, select GPS to use.

Heading: Set the distance from the tip of ship's bow to GPS antenna.

Port (Starboard): Set the position of GPS toward port or starboard from the center line of the ship.

Common 2/Alarm External Output 1,2,3,4

Set types of alarm signals to output from this equipment to alarm units such as FURUNO Bridge Alarm System BR-1000, etc.

Alarm External Output 1/2/3/4 pages correspond to connections of pin No.1/2, No.3/4, No.5/6 and No.7/8 of the TB board J612/P612 inside of the processor unit.

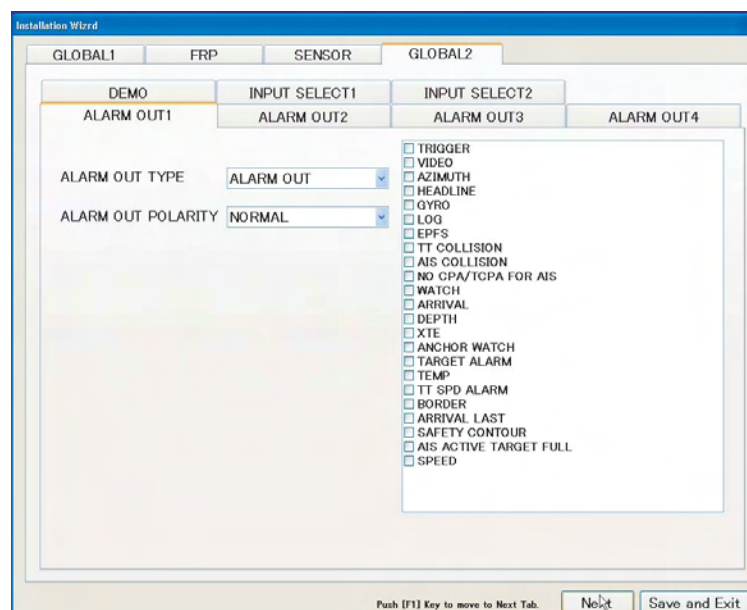

Contact point output: Select among Alarm Output, Operation Report and Alarm Acknowledge as shown below. The wiring diagram at the end of this manual shows the default condition. i.e. Alarm External Output 1, 2 and 3 are for Alarm Output and Alarm External Output 4 is for Operation Report.

Alarm Output: Output contact point signal to the alarm unit connected when problems occur in this equipment. Types of problems are set in the check box on the right side on the screen. Click the check box twice to enter check mark.

No trigger: No trigger signals

No video: No image signal

No turn signal: No bearing signals

Gyro: No gyrocompass bearing

Log: No speed signals from ship speed meter

EPFS: No positioning signals

TT collision alarm: Alarm for collision by the track target function

AIS collision alarm: Alarm for collision by AIS

CPA/TCPA unable to measure: Alarm for CPA/TCPA not set for AIS

Watch alarm: Alarm for watch

Depth alarm: Alarm for depth

XTE alarm: Alarm for course error

Anchor watch alarm: Alarm for anchor watch

Watch alarm: Alarm for target

Water temperature alarm: Alarm for water temperature

TT ship speed alarm: Alarm for ship speed by the track target function.

Border Alarm: Not used in this equipment

Arrival to Final Waypoint: Alarm for arrival at final waypoint

Grounding Warning: Not used in this equipment

AIS Active Full: Alarm for AIS active target full

Ship speed alarm: No ship speed signals from GPS

- Control Report: Output contact signals. For example, it can be used as reset signals for Watch Alarm by connecting to the alarm unit.
- Alarm Acknowledge: Press the [Cancel Alarm] key in the control unit when alarm is generated to stop the alarm and the contact signals are outputted to the alarm unit.

Alarm Output Polarity: Set polarity of output signals according to the equipment connected. Set STANDARD when the other party is Normal Close and set REVERSE when the other party is Normal Open.

Common 2/Demo Mode

This mode can be used at exhibitions, etc.

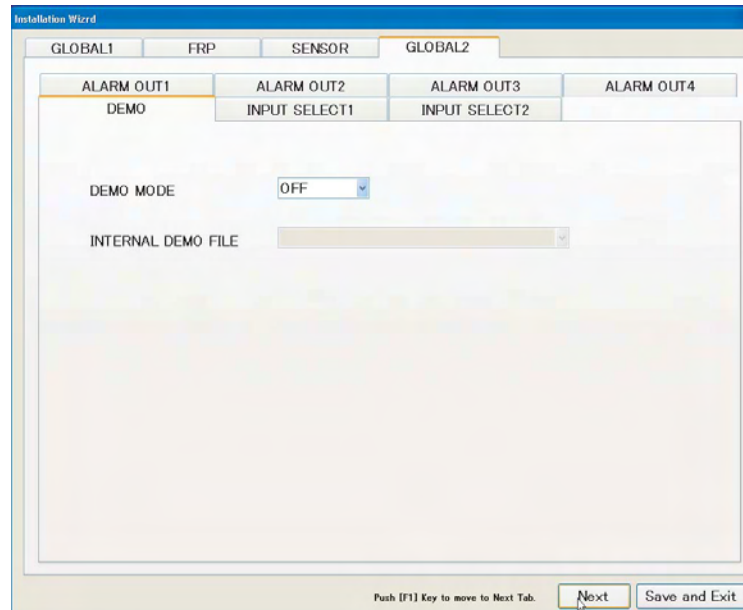

Demo mode: Set OFF in normal condition. Set INTERNAL DEMO when displaying data for demonstration inside of the equipment. Set EXTERNAL DEMO when displaying data for demonstration from external unit connected.

Note: Turn OFF signals from external sensors such as GPS when using Demo mode to display the Demo mode correctly.

Select Internal Demo File: Specify data file for demonstration to display on the screen when the Demo mode is set at INTERNAL DEMO.

Common 2/Source Selection 1/2

Set sources of various data to be displayed on the radar screen. LAN is displayed when no equipment of corresponding signals is connected.

ALARM OUT1	ALARM OUT2	ALARM OUT3	ALARM OUT4
DEMO	INPUT SELECT1	INPUT SELECT2	
NAV AID	GPS		
[L/L] [DATUM]	RD003014(NAVIGATOR)		Priority
[DEAD RECKONING]	RD003014(NAVIGATOR)		
SOG	GPS		
[GPS]	RD003014(NAVIGATOR)		Priority
[TT REFERENCE]	RD003014(NAVIGATOR)		
[LOG BT]	RD003014(NAVIGATOR)		Priority
STW	LOG(WT)		
[LOG WT]	RD003014(NAVIGATOR)		Priority
[MANUAL]	RD003014(NAVIGATOR)		
[DATE]	RD003014(NAVIGATOR)		
[HEADING]	RD003014(AD_10)		Priority

Depending on with/without [Priority order] button, settings are deferent.

- Items with [Priority order]: Click the [Priority] button to set data source. (Setting from the list box is unavailable.)
- Items without [Priority order]: Set data source from the list box.

Using the [Priority order] button

Click the [Priority order] button to display the list of input signals. Reverse the display of the desired selections then using the UP/DOWN arrow button, set the priority order. Click the [OK] button.

Note: When there are no input signals, data sources up to the upper three data sources are switched. In the below case, NAVIGATOR, HEADING and ARPA are switched in that order.

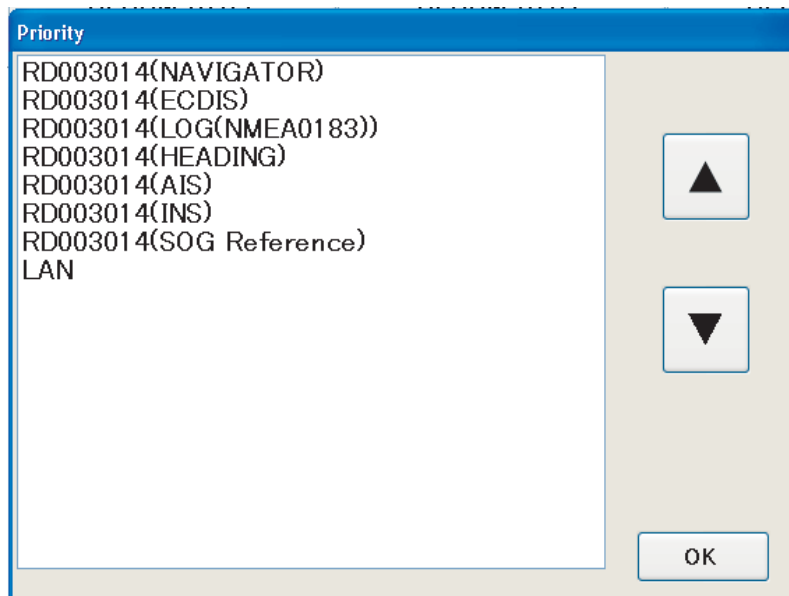

Own ship position: Set data source for own ship position. Set DEAD RECKON when GPS navigation equipment is unavailable to predict own ship position from heading data and ship speed data.

When GPS is selected, set data source from OWN SHIP POSITION and DATUM immediately below GPS. When DEAD RECKON is selected, set data source from DEADREC.

Similarly, set data source for ground speed, water speed, date and time and heading.

In data source selection page 2, set data source for wind direction/speed, tide, water temperature, water depth, AIS and external waypoint.

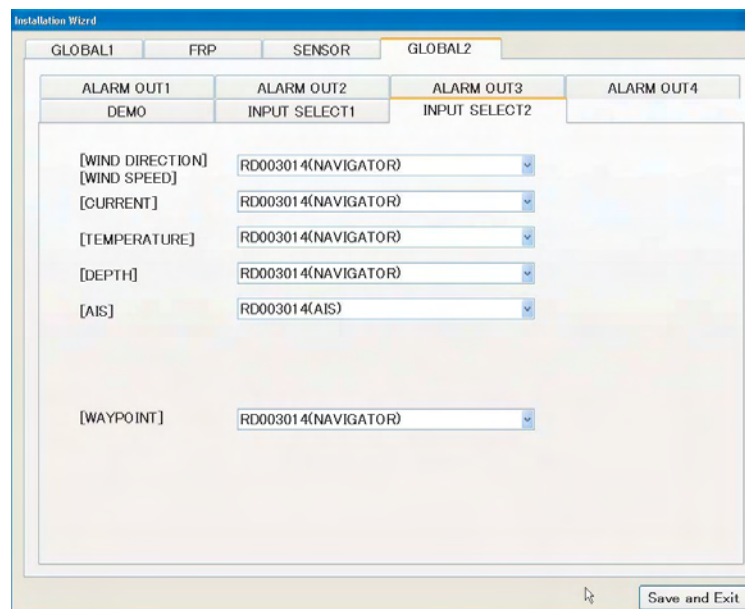

Click the [Save setting/Finish] button when all the settings are done. Wizard disappears and radar restarts. Refer to the corresponding section to adjust radar image.

3.2 Initializing Tuning

Note: “Click” in the following explanations means to click the left button on the trackball.

1. Set the range at 48 NM.
2. Roll the trackball and put the cursor on TUNING on upper right side of the screen then click the right button on the trackball

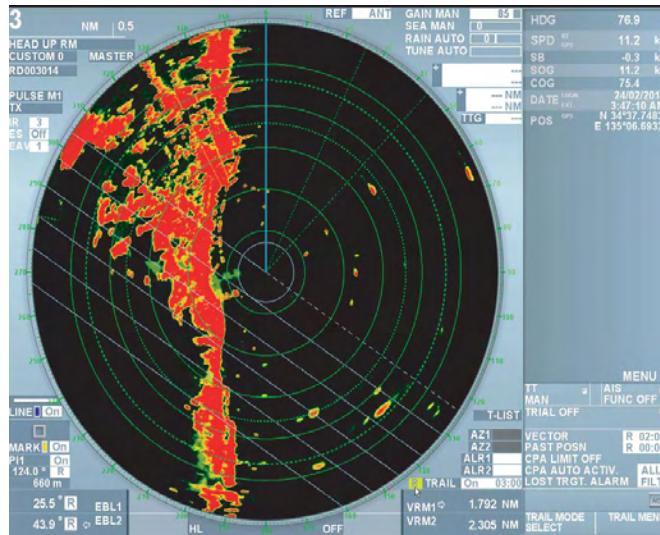

INITIALIZE TUNING appears at the center of the screen.

3. Click INITIALIZE TUNING

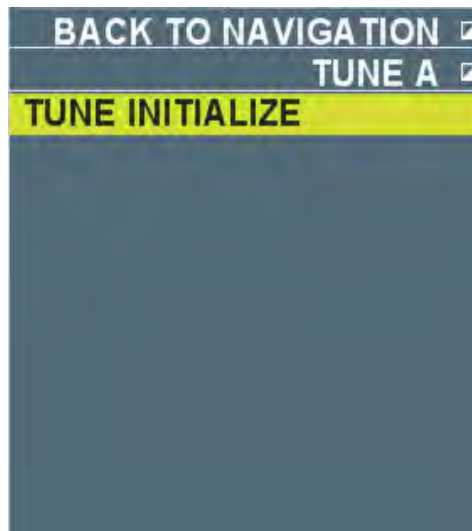

Automatic tuning starts and echo appears on the screen. Blinking message “Other alarm Initializing tuning” appears in yellow during the automatic adjustment. Press the [Cancel Alarm] key. Blinking changes to lighting. Initialization is completed when this message disappears. Rotate the GAIN knob to adjust visibility of the screen.

4. Select RETURN and press the wheel to close the menu.

3.3 Adjustment of Video Level

After initializing tuning, adjust video level. Set the pulse width at LONG and do the following after tuning bar is stable.

1. Press the [Delete target] key five times immediately after pressing the [Delete heading line]. The environment setting menu appears.



2. Click INSTALLATION SETTING. The INSTALLATION SETTING menu appears.

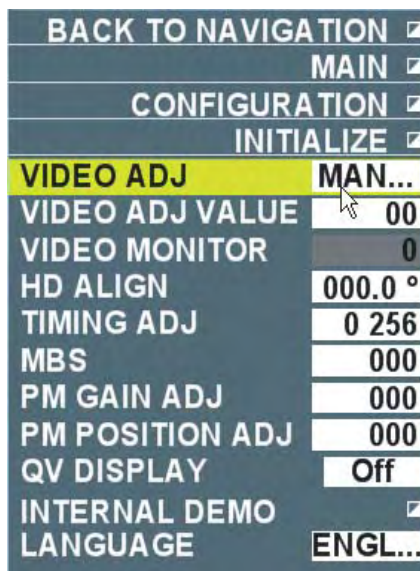

3. Select VIDEO LEVEL ADJUSTMENT and click the button.
4. Select MANUAL in VIDEO LEVEL ADJUSTMENT and then click the button.
5. Input adjustment value according to the length of Antenna Cable (RW-0013).
 - Less than 20 m: 23
 - 20 to 30 m: 25
 - 30 to 50 m: 26 (Currently not used)

3.4 Heading Alignment

Some error may occur when installing the antenna unit. This installation error (timing error of the heading switch) can be rectified in the processor unit.

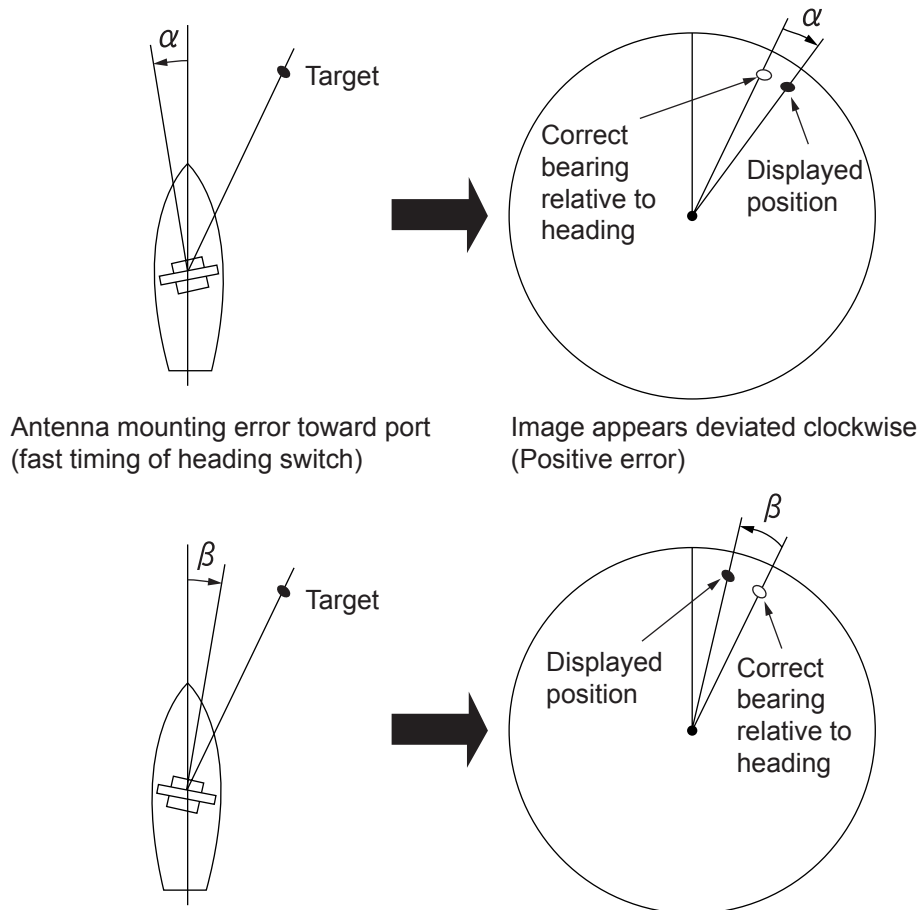

1. Set a range between 0.12t and 0.25 NM and select a target echo ahead near the heading line.
2. Roll the EBL knob to bisect the target echo.
3. Read the target bearing.
4. Measure bearing of the target on the chart to calculate the difference between the actual bearing and apparent bearing on the radar screen.
5. Click HEADING ALIGNMENT on the INSTALLATION SETTING menu.

BACK TO NAVIGATION	▣
MAIN	▣
CONFIGURATION	▣
INITIALIZE	▣
VIDEO ADJ	MAN...
VIDEO ADJ VALUE	00
VIDEO MONITOR	0
HD ALIGN	000.0 °
TIMING ADJ	0 256
MBS	000
PM GAIN ADJ	000
PM POSITION ADJ	000
QV DISPLAY	Off
INTERNAL DEMO	▣
LANGUAGE	ENGL...

- Roll the wheel to input the bearing error. Setting range is 0~359.9°. Initially only integer part is selected. Roll the wheel to set a value. Press the wheel to select the decimal part then roll the wheel to set the value.
- Confirm that target echo is displayed at the correct position on the screen.

3.5 Adjustment of Sweep Timing

Sweep timing differs with respect to the length of the signal cable between the processor unit and the antenna unit. Adjust sweep timing at installation to prevent the symptoms such as the echo of a “straight” target (i.e. pier, jetty), on the 0.25 NM range, appearing on the display as being pulled inward or pushed outward, or the range of target echoes near the center of the screen appearing incorrectly.

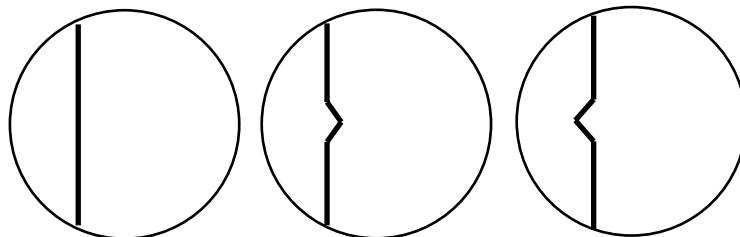

(1) Correct (2) Target pushed inward (3) Target pushed outward

Image of a straight pier at different sweep timings

Method of adjustment

1. Transmit on the 0.25NM range
2. Adjust gain and sea clutter, etc. to display the radar image properly.
3. Display a straight target such as pier and jetty.
4. Click TIMING ADJUSTMENT on the INSTALLATION SETTING menu.

BACK TO NAVIGATION	☑
MAIN	☑
CONFIGURATION	☑
INITIALIZE	☑
VIDEO ADJ	MAN...
VIDEO ADJ VALUE	00
VIDEO MONITOR	0
HD ALIGN	000.0 °
TIMING ADJ	0 256
MBS	000
PM GAIN ADJ	000
PM POSITION ADJ	000
QV DISPLAY	Off
INTERNAL DEMO	☑
LANGUAGE	ENGL...

5. Roll the wheel to set the values so that pier and jetty appear straight and then press the wheel. Setting range is 0~4095.

3.6 Suppressing Main Bang

If main bang appears at the screen center, suppress it as follows.

1. Transmit the radar on a long range and then wait ten minutes.
2. Adjust gain to show a slight amount of noise on the display.
3. Select the 0.25NM range. Adjust sea clutter control to suppress sea clutter to show the clearest image.
4. Click MAIN BANG on the INSTALLATION SETTING menu.

BACK TO NAVIGATION	☑
MAIN	☑
CONFIGURATION	☑
INITIALIZE	☑
VIDEO ADJ	MAN...
VIDEO ADJ VALUE	00
VIDEO MONITOR	0
HD ALIGN	000.0 °
TIMING ADJ	0 256
MBS	000
PM GAIN ADJ	000
PM POSITION ADJ	000
QV DISPLAY	Off
INTERNAL DEMO	☑
LANGUAGE	ENGL...

5. Rotate the wheel to set a suitable value so that the main bang disappears. The setting range is 0 to 255.
6. Press RETURN after adjustment is completed.
7. Press the power supply switch  after all the adjustments are completed. The message "Shutting down..." appears. Release the power supply switch immediately. The power is turned off in about 15 seconds.

3.7 Gyrocompass Signals

Optional Gyro interface board (GC board) 64P1166 is necessary to connect to synchronous signals or step signals of gyrocompass. Do the following in accordance with the specifications of gyrocompass.

DIP Switch, Jumper Setting

Check the following items prior to DIP switch and jumper setting.

Gyrocompass

- AC synchronous
- DC synchronous
- DC step
- Full-wave pulsating current
- Half-wave pulsating current

AC synchronous

- Excitation frequency: 50/60Hz、400Hz、500Hz
- Rotor voltage: AC _____V
- Stator voltage: AC _____V
- Speed up ratio: 360x, 180x, 90x, 36x

DC synchronous

- Rotor voltage: DC _____V
- Stator voltage: DC _____V
- Speed up ratio: 360x, 180x, 90x, 36x

DC step

- Operating voltage: DC _____V
- Speed up ratio: 360x, 180x, 90x, 36x

Full-wave/Half-wave pulsation current step

- Excitation frequency: 50/60Hz、400Hz、500Hz
- Operating voltage: DC _____V
- Speed up ratio: 360x, 180x, 90x, 36x

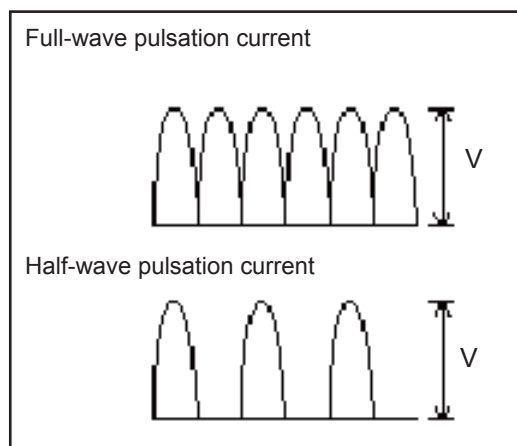

Factory Default Setting

DIP switch and jumper connector on the GC board are ready to be connected to gyrocompass of the following specifications:

- Gyrocompass: AC synchronous
- Frequency: 50/60 Hz
- Rotor voltage: AC60V ~ AC135V
- Stator voltage: AC60V ~ AC135V
- Speed up ratio: 360x
- Operating voltage: AC30V ~ AC135V

Setting Order

If the specifications of gyrocompass are different from the above specifications, change the DIP switch and jumper settings on the GC board in the following order. (When the GC board is installed at factory, the board needs to be removed first. See page 3-24.)

1. Gyrocompass

Gyro method	SW-1-4	SW1-5	SW1-6	JP1
AC synchro	OFF	OFF	OFF	#1, #2, #3
DC synchro	OFF	OFF	OFF	#2, #3, #4
Full-wave pulsation current step	ON	OFF	OFF	#4, #5, #6
Half-wave pulsation current step	OFF	ON	OFF	#4, #5, #6
	ON	ON	OFF	#4, #5, #6

2. Excitation Frequency

Excitation frequency	SW1-7	SW1-8	Notes
50/60 Hz	OFF	OFF	AC synchro, Pulsation current step
400 Hz	ON	OFF	AC synchro, Pulsation current step
500 Hz	OFF	ON	AC synchro, Pulsation current step
DC	ON	ON	DC synchro, DC step

3. Rotor Voltage (between R1 and R2)

Gyrocompass requiring SW2-1 and JP3 settings is only AC synchronous. Rotor voltage of DC synchronous is set at Step 6 Operating Voltage (JP4, JP5).

Rotor voltage	SW2-1	JP3
AC20 V to AC45 V	ON	#2
AC30 V to AC70 V	OFF	#2
AC40 V to AC90 V	ON	#1
AC60 V to AC135 V	OFF	#1

4. Stator Voltage (between S1 and S2)

Stator voltage	SW2-2	SW2-3	JP2
AC20 V to AC45 V or DC20 V to DC60 V	ON	OFF	2
AC30 V to AC70 V or DC40 V to DC100 V	OFF	OFF	2
AC40 V to AC90 V	ON	OFF	1
AC60 V to AC135 V	OFF	OFF	1

5. Speed up ratio

Speed increase ratio	SW1-1	SW1-2	SW1-3
360x	OFF	OFF	OFF
180x	ON	OFF	OFF
90x	OFF	ON	OFF
36x	ON	ON	OFF

6. Operating Voltage

Operating voltage	JP4	JP5
AC20 V to AC45 V or DC20 V to DC60 V	#2	#2
AC20 V to AC135 V or DC4 V to DC100 V	#1	#1

7. Transmission frequency of IEC61162 data, Version, Baud rate. (Not used for FAR-1417/1427) Set according to addressee's of data.]

Transmission frequency	SW2-5	SW2-6	Output sentence
1 second	OFF	OFF	HDT+VHW
200mil. Sec.	ON	OFF	HDT
100mil. Sec.	OFF	ON	HDT
25mil. Sec.	ON	ON	HDT

Version	SW3-1
1.5	OFF
2.0	ON

Baud rate	SW3-2
4.800 bps	OFF
38.400 bps	ON

Turn OFF the DIP switch SW2-8 from ON and reset CPU.

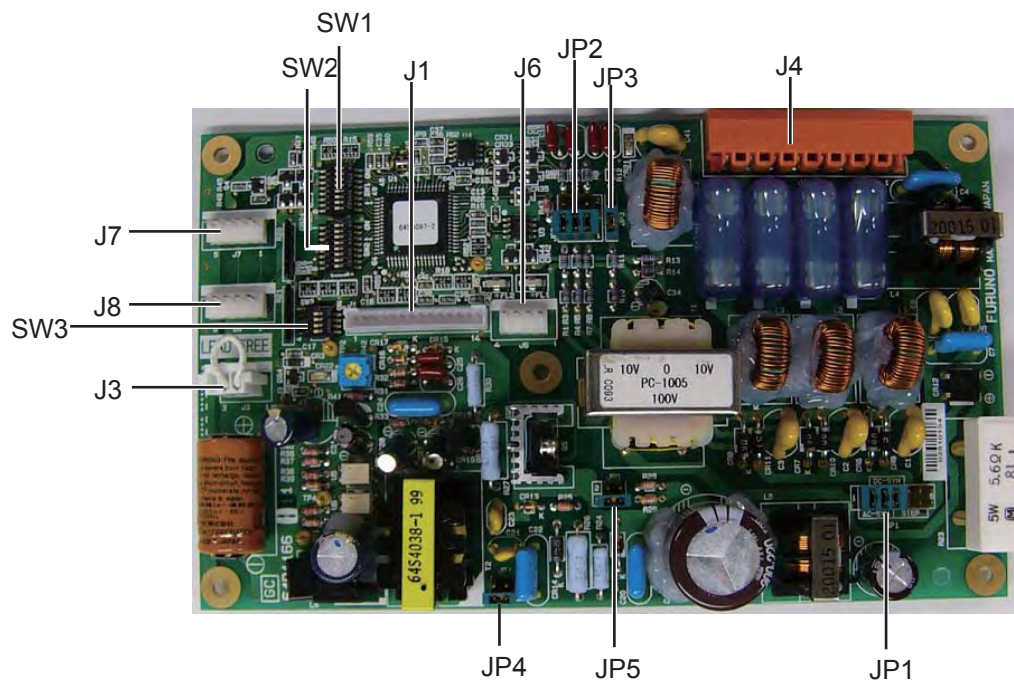

Installing GC board

Follow the following steps when installing the GC board on site. When the GC board is pre-installed and shipped at factory and the DIP switch and jumper wire need to be changed, refer to the following description to remove the GC board first. After the setting, reinstall the GC board.

Gyro converter GC-100-2, Code No.000-017-044

Name	Type	Code No.	Q'ty
GC board	64P1166	001-103-040-00	1
NH connector	03-2290	001-105-020-00	1
PH-XH connector	03-2328 (P14-6P)	001-105-010-00	1
Connector	231-308/026-FUR	000-150-114-11	1

1. Open the lid of the processor unit.
2. Remove the five connectors on the TB board/VIDEO AMP board. The connectors at five locations need to be removed. See the picture below.
3. Remove four screws fastening the mounting base of the TB board/VIDEO AMP board and loosen one screw to remove the mounting base.

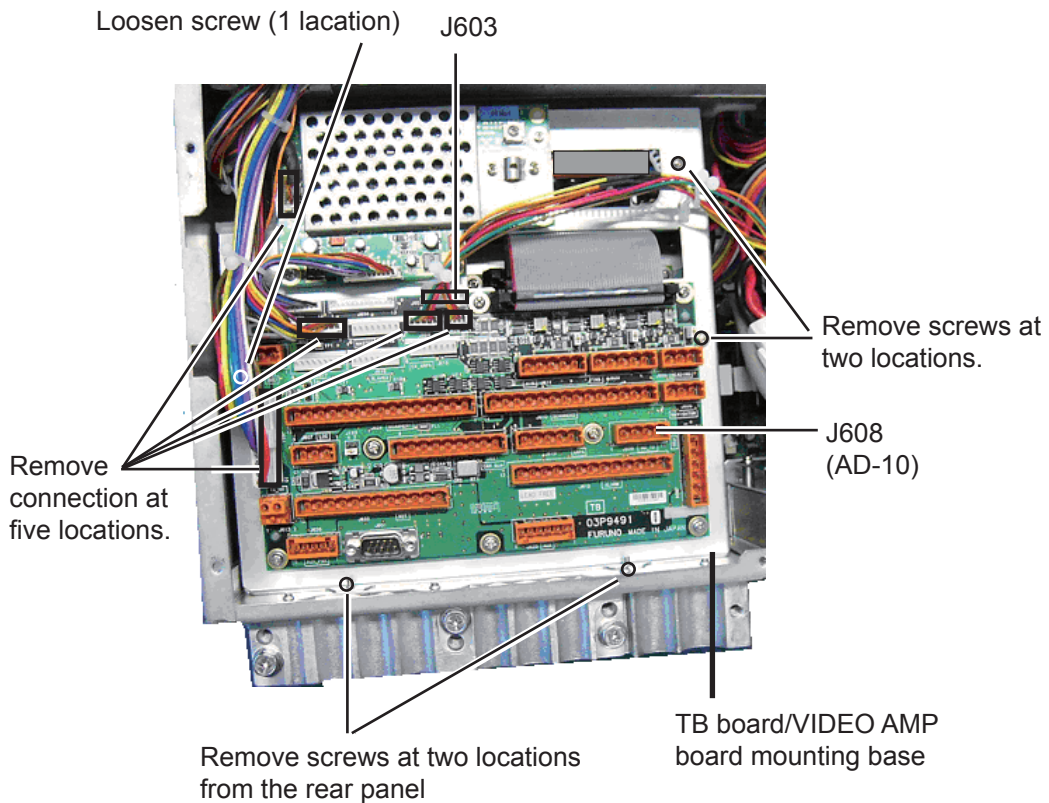

- Loosen two screws in the processor unit and remove the GC mounting base. (Screws only need to be loosened.)

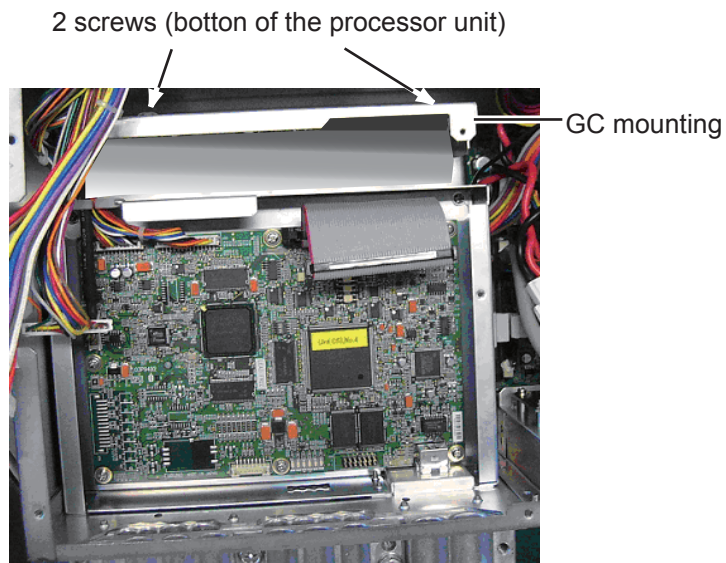

- Attach the GC board to the GC mounting base (The GC board is fastened with five screws at five locations). Install the NH connector (cable assembly) and PH-XH connector (cable assembly) to J7 and J1 accordingly.

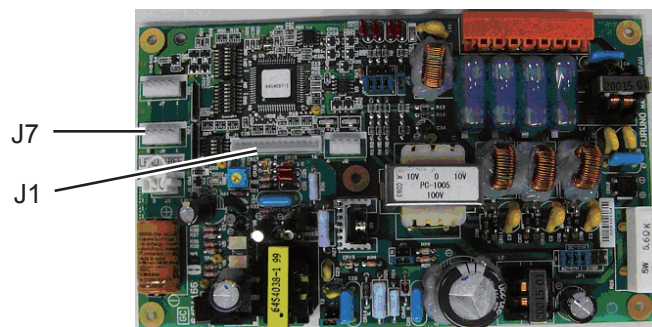

- Reinstall the GC mounting base.

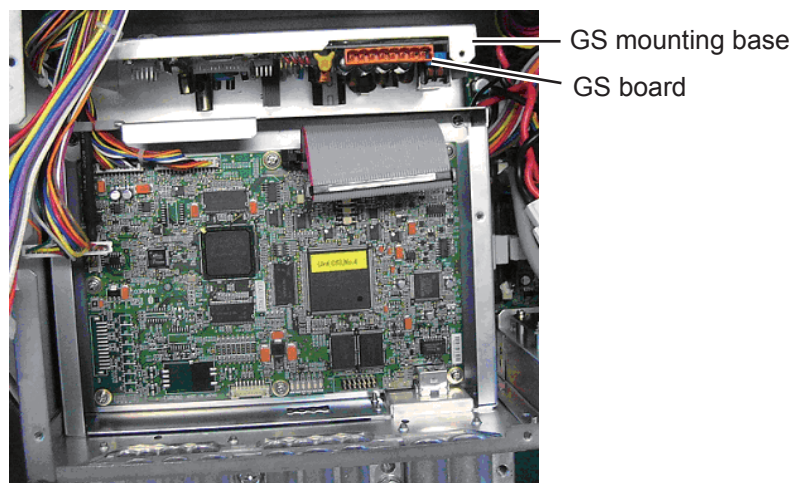

After GC board is mounted

7. Reinstall the mounting base of the TB board/VIDEO AMP board and fasten the connectors removed at step 2.
8. Connect the six pin connectors of the cable assembly on the GC board to J603 on the TB board. (See the illustration at step 3 above.)
9. Connect the other cable assembly on the GC board to 231-308/026-FUR to connect to J608 on the TB board. See page 2-11 for installation of the 231-308/026 –FUR connector.

Setting Bearing

Read heading of gyrocompass. Check the heading displayed on the radar screen with the gyrocompass reading.

1. Click the MENU at about middle on the right side of the screen to display the main menu.
2. Click ECHO to display the echo menu.

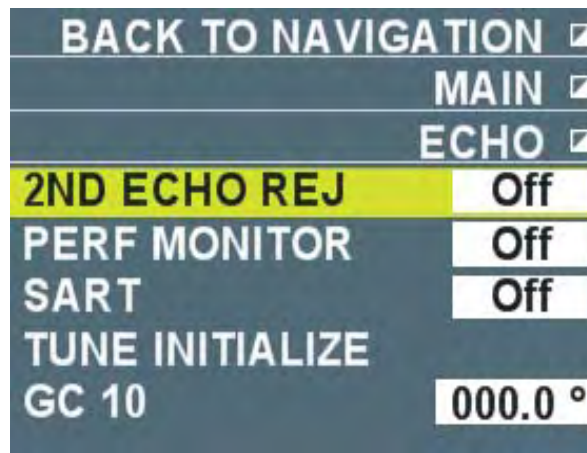

3. Click [GC-10] to read the gyrocompass reading.
4. Right click several times to close the menu.
5. Confirm that the heading tracks with the movement of the gyrocompass.

4. Input Signal

This equipment inputs and outputs signals in NMEA0183 format and CAN bus format. The table below shows the details. There are six NMEA signal ports and each has different input/output sentences. Equipment and signals to be connected are as follows.

Signal Port Name	Connecting equipment	Port No.
NMEA1	GPS navigation equipment	J606
NMEA2	ECDIS	J619
NMEA3	Ship speed meter	J607
NMEA4	Heading bearing signal	J605
NMEA5	AIS	J611
NMEA6	INS	J620

Absolute maximum

Input: Current 50 mA, Voltage 6 V

Output: Voltage supply 16 V

Out voltage (Higt): 16V

Output corrent (Low): 50 mA

4.1 NMEA Input Sentence

- Talker is arbitrary.
- Baud rate 4800 ~ 38400 bps
- NMEA0183, Ver.1.5, 2.0, 3.0

BWC	Range and bearing to waypoint (Great circle route)
BWR	Range and bearing to waypoint (Rhumb line)
CUR	Current data
DBK	Water depth from keel
DBS	Water depth from sea surface
DBT	Water depth from transceiver
DPT	Water depth
DTM	Datum
GBS	Detection of GPS error
GGA	GPS positioning data
GLL	Latitude/longitude, UTC positioning
GNS	GNSS positioning data
HDG	Heading (Magnetic bearing), variation data
HDT	Heading (True bearing)
MTW	Water temperature
MWV	Wind direction/Wind speed
RMA	Navigation data
RMB	Navigation data
RMC	Navigation data
THS	True bearing
VBW	Dual-axis ground/water ship speed
VDR	Drift speed (Set, Drift)
VHW	Water speed, Heading bearing

VTG	True course, Ground speed
VWR	Relative wind direction/wind speed
VWT	True wind direction/wind speed
ZDA	Current UTC time

NMEA5 (AIS)

- Talker is AI
- Baud rate 4800~38400 bps
- NMEA0183, Ver.1.5, 2.0, 3.0

ABK	Specify addressee/Broadcast acknowledge data
ALR	Alarm setting status
VDM	VHF data link message
VDO	VHF data link Own ship report

NMEA6 (INS)

ACK	Acknowledge (Talker is arbitrary.)
PFEC. pireq	Type name, Transmissible NMEA data
PFEC. pidat	Type name, Transmissible NMEA data

4.2 NMEA Output Sentence

NMEA2 (ECDIS)

- Talker is RA
- Baud rate 4800/38400 bps
- NMEA0183, Ver.3.0

AAM	Arrival alarm
ALR	Alarm setting status
APB	Data for auto pilot
BOD	Bearing from start point to waypoint
OSD	Own ship data
RMB	Navigation information
RSD	Radar system data
TLL	Target latitude/longitude
TTM	Track target information

NMEA5 (AIS)

- Talker is RA
- Baud rate 4800/38400 bps
- NMEA0183, Ver.3.0

ABM	Address specified binary safety related message
ACK	Acknowledge
BBM	Broadcast binary message
VSD	Voyage static data

NMEA6 (INS)

ALR	Alarm setting status
OSD	Own ship data
RSD	Radar system data
TLL	Target latitude/longitude
PFEC. pidat	Data of specified property
PEEC. prireq	Output request for specified property

4.3 CAN bus port Input/output

Input PGN

059392	ISO Acknowledgement
059904	ISO Request
060928	ISO Address Claim
061184	Self Test Group Function
126208	NMEA - Request group function
126208	NMEA - Command group function
126208	NMEA - Acknowledge group
126720	Memory Clear Group Function
126720	Reset Group Function
126992	System Time
126996	Product Information
126250	Vessel Heading
127259	Speed, Water referenced
128267	Water, Depth
129025	Position, Rapid Update
129026	COG & SOG Rapid Up date
129029	GNSS Position Data
129033	Time & Date
129044	Datum
129545	GNSS RAIM Output
130306	Wind Data
130310	Environmental Parameters
130511	Environmental Parameters
130577	Direction Data
130816	Self Test Report
130822	Unit Division Code
130823	Browser Control Status.



Output PGN

059392	ISO Acknowledgement
059904	ISO Request
060928	ISO Address Claim
061184	Self Test Group Function
126208	NMEA - Request group function
126208	NMEA - Command group function
126208	NMEA – Acknowledge group function
126464	PGN List – Received PGN7s group function
126464	PGN List – Received PGN7s group function
126996	Product Information
130821	NAV Source Select
130822	Unit Division Code
130823	Browser Control Status

PACKING LIST

RSB-132-110

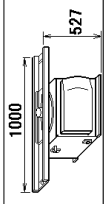
03HH-X-9851 -0 1/1



NAME	OUTLINE	DESCRIPTION/CODE No.	QTY
ユニット			
空中線本体部 ANTENNA DRIVE UNIT		RSB-132-110 000-020-274-00	1
付属品			
ACCESSORIES			
付属品 ACCESSORIES		FP03-10101 008-538-730-00	1
工事材料			
INSTALLATION MATERIALS			
工事材料 INSTALLATION MATERIALS		OP03-34301 001-169-300-00	1

型式・コート番号が2段の場合、下段より上段に代わる過渡期品であり、どちらが入っています。なお、品質は変わりません。
TWO TYPES AND CODES MAY BE LISTED FOR AN ITEM. THE LOWER PRODUCT MAY BE SHIPPED IN PLACE OF THE UPPER PRODUCT. QUALITY IS THE SAME.
(略図の寸法は、参考値です。DIMENSIONS IN DRAWING FOR REFERENCE ONLY.) 03HH-X-9851

PACKING LIST

RCU-021-J/E

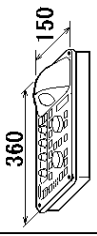
03HE-X-9852 -1 1/1

NAME	OUTLINE	DESCRIPTION/CODE No.	QTY
ユニット			
操作部 CONTROL UNIT		RCU-021-E 000-016-993-00 ** CP03-33200	1
工事材料			
INSTALLATION MATERIALS			
KB取付金具 KB FIXTURE ASSEMBLY		CP03-33202 001-115-510-00	1
工事材料 INSTALLATION MATERIALS		CP03-33201 001-104-970-00	1

コート番号末尾の**は、選択品の代替コードを表します。
CODE NUMBER ENDING WITH "**" INDICATES THE CODE NUMBER OF REPRESENTATIVE MATERIAL.

型式・コート番号が2段の場合、下段より上段に代わる過渡期品であり、どちらが入っています。なお、品質は変わりません。
TWO TYPES AND CODES MAY BE LISTED FOR AN ITEM. THE LOWER PRODUCT MAY BE SHIPPED IN PLACE OF THE UPPER PRODUCT. QUALITY IS THE SAME.
(略図の寸法は、参考値です。DIMENSIONS IN DRAWING FOR REFERENCE ONLY.) 03HE-X-9852

PACKING LIST RPU021-67J*/60KE* (AC100)

03HH-X-9852-0

1/1

A-2

NAME	OUTLINE	DESCRIPTION/CODE No.	Q'TY
ユニット UNIT			
制御部 PROCESSOR UNIT		RPU021-67J6R2M19S24N 000-020-286-00 **	1
予備品 SPARE PARTS			
予備品 SPARE PARTS		SPO3-16301 001-104-910-00	1
工事材料 INSTALLATION MATERIALS CP03-33330			
ケーブル組品 CABLE ASSEMBLY		DV1-D/D S-LINK 5M 001-132-960-10	1
ケーブル組品 CABLE ASSEMBLY		RNS-08-132 001-107-540-10	1
ケーブル組品LAN LAN CABLE ASSEMBLY		MOD-Z072-005+ 000-174-113-10	1
工事材料 INSTALLATION MATERIALS		CP03-33301 001-104-940-00	1
図書J DOCUMENT (J)			
技適認証要領 APPLICATION GUIDE		J32-00501-* 000-153-768-1*	1

1.コード番号末尾の[**]は、選択品の代表コードを表します。
CODE NUMBER ENDING WITH "**" INDICATES THE CODE NUMBER OF REPRESENTATIVE MATERIAL.

2.図書は、英文・和文仕様で選択願います。
CHOOSE JAPANESE OR ENGLISH ACCESSORIES.

(略図の寸法は、参考値です。DIMENSIONS IN DRAWING FOR REFERENCE ONLY.)

NAME	OUTLINE	DESCRIPTION/CODE No.	Q'TY
取扱説明書(和) OPERATOR'S MANUAL		OMJ-35840-* 000-173-817-1*	1
操作要領書(和) OPERATOR'S GUIDE		OSJ-35840-* 000-173-819-1*	1
装備要領書(和) INSTALLATION MANUAL		IMJ-36120-* 000-175-807-1*	1

図書E DOCUMENT (E)

取扱説明書(英) OPERATOR'S MANUAL		OME-36120-* 000-175-804-1*	1
操作要領書(英) OPERATOR'S GUIDE		OSE-36120-* 000-175-805-1*	1
装備要領書(英) INSTALLATION MANUAL		IME-36120-* 000-175-808-1*	1

型式/コード番号が2段の場合、下段より上段に代わる過渡期品であり、どちらが入っています。なお、品質は変わりません。

TWO TYPES AND CODES MAY BE LISTED FOR AN ITEM. THE LOWER PRODUCT MAY BE SHIPPED IN PLACE OF THE UPPER PRODUCT. QUALITY IS THE SAME.

03HH-X-9852

PACKING LIST RPU021-67J*/60KE* (AC220)

03HH-X-9854-0

1/1

NAME	OUTLINE	DESCRIPTION/CODE No.	Q'TY
ユニット UNIT			
制御部 PROCESSOR UNIT		RPU021-67J7R2M19S24N 000-020-287-00 **	1
予備品 SPARE PARTS			
予備品 SPARE PARTS		SPO3-16302 001-104-920-00	1
工事材料 INSTALLATION MATERIALS CP03-33330			
ケーブル組品 CABLE ASSEMBLY		DV1-D/D S-LINK 5M 001-132-960-10	1
ケーブル組品 CABLE ASSEMBLY		RNS-08-132 001-107-540-10	1
ケーブル組品LAN LAN CABLE ASSEMBLY		MOD-Z072-005+ 000-174-113-10	1
工事材料 INSTALLATION MATERIALS		CP03-33301 001-104-940-00	1
図書J DOCUMENT (J)			
技適認証要領 APPLICATION GUIDE		J32-00501-* 000-153-768-1*	1

1.コード番号末尾の[**]は、選択品の代表コードを表します。
CODE NUMBER ENDING WITH "**" INDICATES THE CODE NUMBER OF REPRESENTATIVE MATERIAL.

2.図書は、英文・和文仕様で選択願います。
CHOOSE JAPANESE OR ENGLISH ACCESSORIES.

(略図の寸法は、参考値です。DIMENSIONS IN DRAWING FOR REFERENCE ONLY.)

NAME	OUTLINE	DESCRIPTION/CODE No.	Q'TY
取扱説明書(和) OPERATOR'S MANUAL		OMJ-35840-* 000-173-817-1*	1
操作要領書(和) OPERATOR'S GUIDE		OSJ-35840-* 000-173-819-1*	1
装備要領書(和) INSTALLATION MANUAL		IMJ-36120-* 000-175-807-1*	1

図書E DOCUMENT (E)

取扱説明書(英) OPERATOR'S MANUAL		OME-36120-* 000-175-804-1*	1
操作要領書(英) OPERATOR'S GUIDE		OSE-36120-* 000-175-805-1*	1
装備要領書(英) INSTALLATION MANUAL		IME-36120-* 000-175-808-1*	1







型式/コード番号が2段の場合、下段より上段に代わる過渡期品であり、どちらが入っています。なお、品質は変わりません。

TWO TYPES AND CODES MAY BE LISTED FOR AN ITEM. THE LOWER PRODUCT MAY BE SHIPPED IN PLACE OF THE UPPER PRODUCT. QUALITY IS THE SAME.

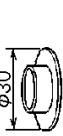
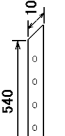
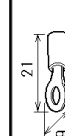
03HH-X-9854

CODE NO.	001-169-300-00	03HH-X-9401 -1
TYPE	CP03-34301	1/2

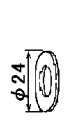
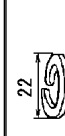
工事材料表

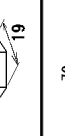
INSTALLATION MATERIALS		数量 Q'TY		用途/備考 REMARKS	
番号 NO.	名称 NAME	略図 OUTLINE	型名/規格 DESCRIPTIONS	数量 Q'TY	用途/備考 REMARKS
1	シ-アワシ- SEAL WASHER		03-001-3002-0 ROHS CODE NO. 300-130-020-10	8	
2	防蝕コ- CORROSION-PROOF RUBBER		03-180-3041-0 CODE NO. 100-370-870-10	2	
3	圧着端子 CRIMP-ON LUG		FV2-4 BLU CODE NO. 100-157-247-10	3	
4	圧着端子 CRIMP-ON LUG		FV5.5-4(LF) YEL CODE NO. 100-166-744-10	1	
5	O-リング O-RING		JBIAG-60 CODE NO. 100-171-766-10	2	
6	フラット平座金 FLAT WASHER		M12 SUS304 CODE NO. 100-167-446-10	8	
7	平座金 SPRING WASHER		M12 SUS304 CODE NO. 100-167-397-10	8	
8	六角ナット HEXAGONAL NUT		M12 SUS304 CODE NO. 100-167-491-10	16	
9	六角ナット 全紗 HEXAGONAL HEAD SCREW		M12X70 SUS304 CODE NO. 100-162-814-10	8	
10	六角ナット HEXAGONAL NUT		M6 SUS304 CODE NO. 100-158-856-10	1	

型式/コード番号が2段の場合、下段より上段に代わる標準部品であり、どちらかが入っています。なお、品質は変わりません。
TWO TYPES AND CODES MAY BE LISTED FOR AN ITEM. THE LOWER PRODUCT MAY BE SHIPPED IN PLACE OF THE UPPER PRODUCT.
QUALITY IS THE SAME.
(略図の寸法は、参考値です。 DIMENSIONS IN DRAWING FOR REFERENCE ONLY.)

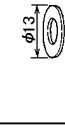
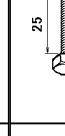
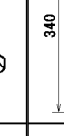

CODE NO.	001-169-300-00	03HH-X-9401 -1
TYPE	CP03-34301	2/2

工事材料表

INSTALLATION MATERIALS		数量 Q'TY		用途/備考 REMARKS	
番号 NO.	名称 NAME	略図 OUTLINE	型名/規格 DESCRIPTIONS	数量 Q'TY	用途/備考 REMARKS
11	平座金 SPRING WASHER		M6 SUS304 CODE NO. 100-158-855-10	1	
12	フラット平座金 FLAT WASHER		M6 SUS304 CODE NO. 100-158-854-10	3	
13	六角ナット HEXAGONAL HEAD BOLT		M6X25 SUS304 CODE NO. 100-162-871-10	1	
14	ケーブル組品 CABLE ASSY.		RW-4747 CODE NO. 100-566-000-12	1	

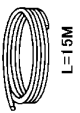
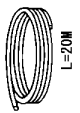

型式/コード番号が2段の場合、下段より上段に代わる標準部品であり、どちらかが入っています。なお、品質は変わりません。
TWO TYPES AND CODES MAY BE LISTED FOR AN ITEM. THE LOWER PRODUCT MAY BE SHIPPED IN PLACE OF THE UPPER PRODUCT.
QUALITY IS THE SAME.
(略図の寸法は、参考値です。 DIMENSIONS IN DRAWING FOR REFERENCE ONLY.)

CODE NO.	03HE-X-9404-1
TYPE	1/1

工事材料表		INSTALLATION MATERIALS		FAR-1417/1427	
番号 NO.	名称 NAME	略図 OUTLINE	型名/規格 DESCRIPTIONS	数量 Q'TY	用途/備考 REMARKS
1	ケーブル(29C) 29 CORE CABLE	 L=15M	RW-0013 *15M* CODE NO. 001-106-800-10	1	選択 TO BE SELECTED
2	ケーブル(29C) 29 CORE CABLE	 L=20M	RW-0013 *20M* CODE NO. 001-106-810-10	1	選択 TO BE SELECTED
3	ケーブル(29C) 29 CORE CABLE	 L=30M	RW-0013 *30M* CODE NO. 001-106-820-10	1	選択 TO BE SELECTED

型式/コード番号が2段の場合、下段より上段に代わる通線部品であり、どちらが入っています。なお、品質は変わりません。
TWO TYPES AND CODES MAY BE LISTED FOR AN ITEM. THE LOWER PRODUCT MAY BE SHIPPED IN PLACE OF THE UPPER PRODUCT.
QUALITY IS THE SAME. DIMENSIONS IN DRAWING FOR REFERENCE ONLY.)
★

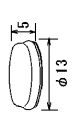
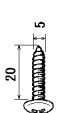
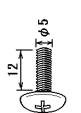
CODE NO.	001-104-970-00
TYPE	CP03-33201

工事材料表		INSTALLATION MATERIALS		RCU-021	
番号 NO.	名称 NAME	略図 OUTLINE	型名/規格 DESCRIPTIONS	数量 Q'TY	用途/備考 REMARKS
1	キャップ CAP	 φ13 5	03-177-2204-0 CODE NO. 100-35E-880-10	4	
2	タップネジ TAPPING SCREW	 20 5	5X20 SUS304 CODE NO. 000-171-997-10	4	
3	バンドネジ BINDING HEAD SCREW	 12 φ5	M5X12 SUS304 CODE NO. 000-171-999-10	4	
4	波座金 WAVE WASHER	 9	MW-5 SUS CODE NO. 000-167-383-10	4	

型式/コード番号が2段の場合、下段より上段に代わる通線部品であり、どちらが入っています。なお、品質は変わりません。
TWO TYPES AND CODES MAY BE LISTED FOR AN ITEM. THE LOWER PRODUCT MAY BE SHIPPED IN PLACE OF THE UPPER PRODUCT.
QUALITY IS THE SAME. DIMENSIONS IN DRAWING FOR REFERENCE ONLY.)

CODE NO.	008-572-750-00	036X-X-9402 -1	1/1
TYPE	CP03-31401		

工事材料表

INSTALLATION MATERIALS

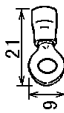
番号 NO.	名称 NAME	略図 OUTLINE	型名/規格 DESCRIPTIONS	数量 Q'TY	用途/備考 REMARKS
1	圧着端子 CRIMP-ON LUG		FV2-4 CODE NO. 000-157-247-10	14	

型式/コード番号が2段の場合、下段より上段に代わる通線部品であり、どちらかが入っています。なお、品質は変わりません。
TWO TYPES AND CODES MAY BE LISTED FOR AN ITEM. THE LOWER PRODUCT MAY BE SHIPPED IN PLACE OF THE UPPER PRODUCT. QUALITY IS THE SAME.
(略図の寸法は、参考値です。 DIMENSIONS IN DRAWING FOR REFERENCE ONLY.)

CODE NO.	001-115-510-00	03HE-X-9407 -0	1/1
TYPE	CP03-33202		

工事材料表

RCU-021, FSV-8601

INSTALLATION MATERIALS

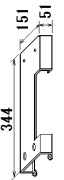
番号 NO.	名称 NAME	略図 OUTLINE	型名/規格 DESCRIPTIONS	数量 Q'TY	用途/備考 REMARKS
1	KB取付金具 KB FIXTURE		03-177-220-0 CODE NO. 100-35E-860-10	1	

型式/コード番号が2段の場合、下段より上段に代わる通線部品であり、どちらかが入っています。なお、品質は変わりません。
TWO TYPES AND CODES MAY BE LISTED FOR AN ITEM. THE LOWER PRODUCT MAY BE SHIPPED IN PLACE OF THE UPPER PRODUCT. QUALITY IS THE SAME.
(略図の寸法は、参考値です。 DIMENSIONS IN DRAWING FOR REFERENCE ONLY.)

CODE NO.	001-104-940-00	03HE-X-9403 -1
TYPE	CP03-33301	1/1

工事材料表

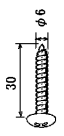
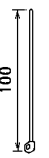
INSTALLATION MATERIALS		RPU-021/021A			
番号 NO.	名称 NAME	略図 OUTLINE	型名/規格 DESCRIPTIONS	数量 Q'TY	用途/備考 REMARKS
1	1/2インチ SELF-TAPPING SCREW		6X30 SUS304 CODE NO. 000-162-614-10	4	
2	ケーブル CABLE TIE		CV-100N CODE NO. 000-162-167-10	5	

型式/コード番号が2段の場合、下段より上段に代わる標準部品であり、どちらかが入っています。なお、品質は変わりません。
TWO TYPES AND CODES MAY BE LISTED FOR AN ITEM. THE LOWER PRODUCT MAY BE SHIPPED IN PLACE OF THE UPPER PRODUCT.
QUALITY IS THE SAME. DIMENSIONS IN DRAWING FOR REFERENCE ONLY.)
(略図の寸法は、参考値です。)

CODE NO.	008-538-730-00	0360-X-9501 -1
TYPE	FP03-10101	1/1

付属品表

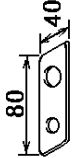
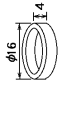
ACCESSORIES					
番号 NO.	名称 NAME	略図 OUTLINE	型名/規格 DESCRIPTIONS	数量 Q'TY	用途/備考 REMARKS
1	吊り上げ金具 LIFTING FIXTURE		03-015-3233-0 ROHS CODE NO. 100-090-720-10	2	
2	取付用カ COLLAR FOR LIFTING FIXTURE		03-015-3234-0 ROHS CODE NO. 100-090-730-10	2	

型式/コード番号が2段の場合、下段より上段に代わる標準部品であり、どちらかが入っています。なお、品質は変わりません。
TWO TYPES AND CODES MAY BE LISTED FOR AN ITEM. THE LOWER PRODUCT MAY BE SHIPPED IN PLACE OF THE UPPER PRODUCT.
QUALITY IS THE SAME. DIMENSIONS IN DRAWING FOR REFERENCE ONLY.)
(略図の寸法は、参考値です。)

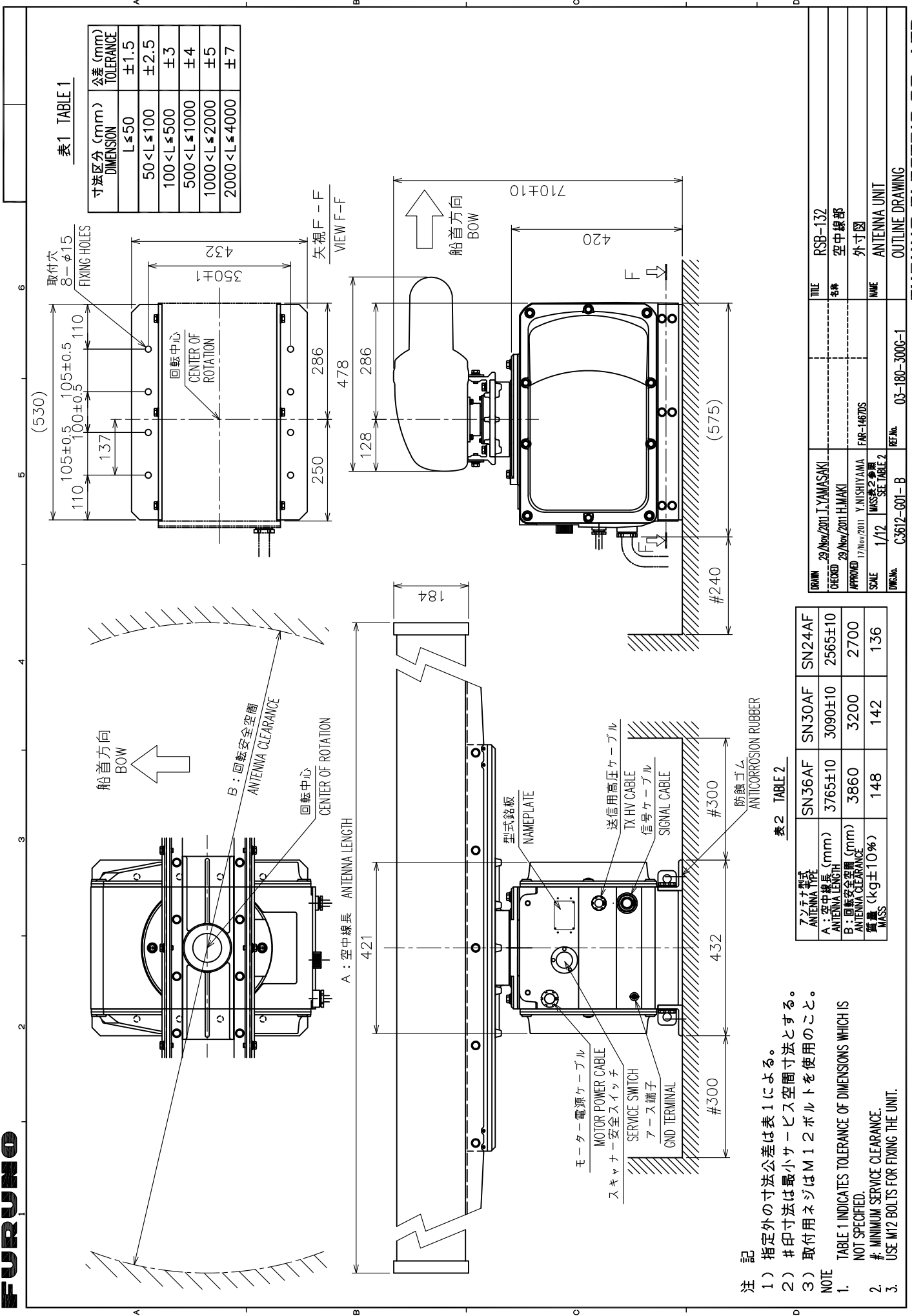

注記
 1) 指定外の寸法公差は表1による。
 2) #印寸法は最小サービス空間寸法とする。
 3) 取付用ネジはM12ボルトを使用のこと。
 NOTE
 1. TABLE 1 INDICATES TOLERANCE OF DIMENSIONS WHICH IS NOT SPECIFIED.
 2. # MINIMUM SERVICE CLEARANCE.
 3. USE M12 BOLTS FOR FIXING THE UNIT.

DRAWN	29/Nov/2011 I.YAMASAKI	TITLE	RSB-132
CHECKED	29/Nov/2011 H.MAKI	名称	空中線部
APPROVED	17/Nov/2011 Y.NISHIYAMA	外寸図	
SCALE	1/12	NAME	ANTENNA UNIT
FIG.No.	C-3612-G01-B	REF.No.	03-180-300G-1
			OUTLINE DRAWING



表1 TABLE 1

寸法区分 (mm) DIMENSION	公差 (mm) TOLERANCE
L ≤ 50	±1.5
50 < L ≤ 100	±2.5
100 < L ≤ 500	±3

- 注記 1) 指定外の寸法公差は表1による。
 2) #印寸法は最小サービスクリアランスとする。
 3) 取付にはトラスチックピンネジ呼び径6×30を使用のこと。
- NOTE 1. TABLE 1 INDICATES TOLERANCE OF DIMENSIONS WHICH IS NOT SPECIFIED.
 2. #: MINIMUM SERVICE CLEARANCE.
 3. USE TAPPING SCREWS φ6x30 FOR FIXING THE UNIT.

DRAWN	15/Nov/2011	T.YAMASAKI	TITLE	RPU-021
CHECKED	15/Nov/2011	H.MAKI	名称	制御部 (壁掛装備)
APPROVED	17/Nov/2011	Y.NISHIYAMA	外寸図	
SCALE	1/6	質量 17.5 kg	NAME	PROCESSOR UNIT (BULKHEAD MOUNT)
DWG.No.	C3584-G01-C	REF.No.	03-177-100G-0	OUTLINE DRAWING

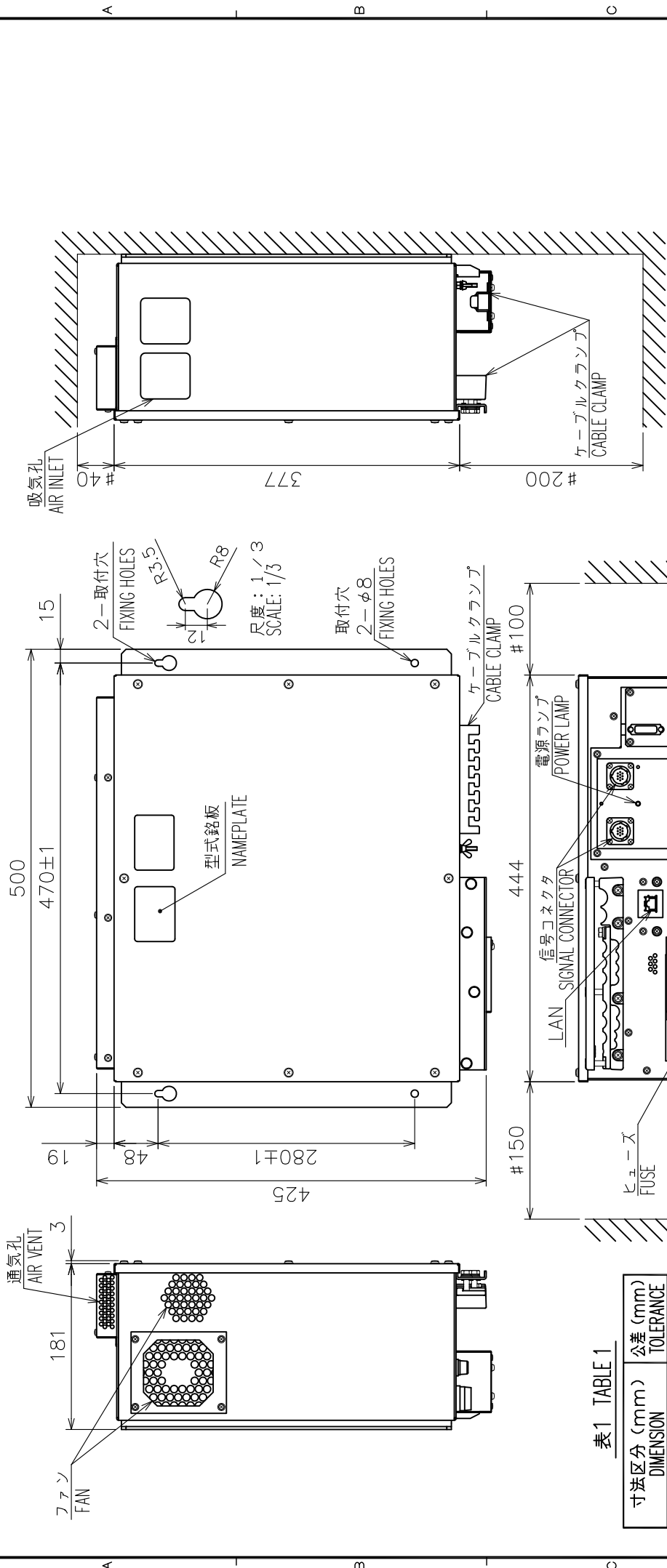
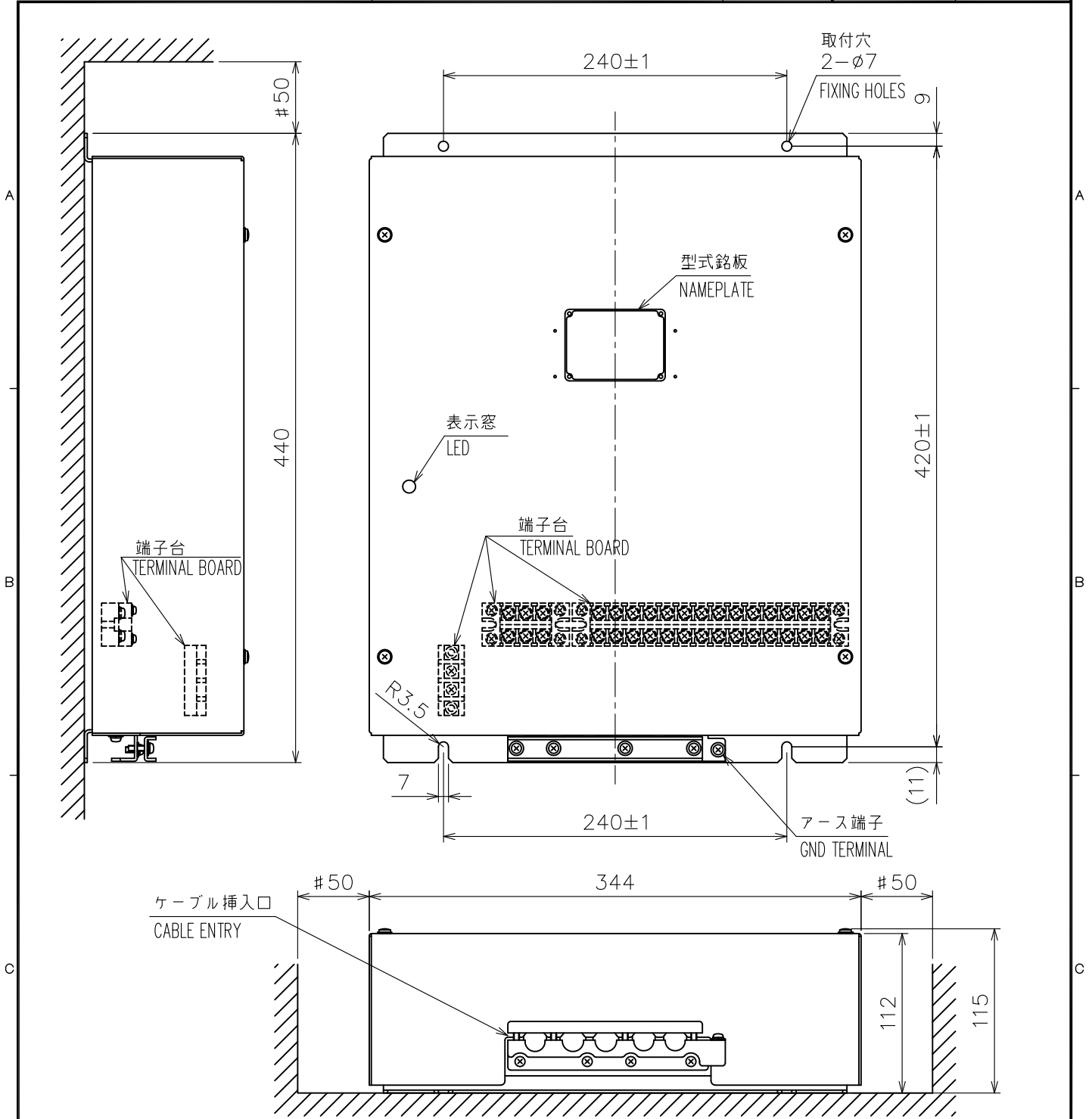

注 記

- 1) 指定外の寸法公差は表 1 による。
- 2) #印寸法は最小サービス空間寸法とする。
- 3) 取付用ネジはトラスタッピンネジ呼び径 6×20 を使用のこと。

NOTE

1. TABLE 1 INDICATES TOLERANCE OF DIMENSIONS WHICH IS NOT SPECIFIED.
2. #: MINIMUM SERVICE CLEARANCE.
3. USE TAPPING SCREWS $\phi 6 \times 20$ FOR FIXING THE UNIT.

表1 TABLE 1

寸法区分 (mm) DIMENSION	公差 (mm) TOLERANCE
$L \leq 50$	± 1.5
$50 < L \leq 100$	± 2.5
$100 < L \leq 500$	± 3

DRAWN 15/Nov/2011 T.YAMASAKI	TITLE PSU-006
CHECKED 15/Nov/2011 H.MAKI	名称 電源制御部
APPROVED 17/Nov/2011 Y.NISHIYAMA	外寸図
SCALE 1/4	NAME POWER UNIT
MASS 5.2 $\pm 10\%$ kg	OUTLINE DRAWING
DWG.No. C3523-G01-B	REF.No. 03-171-900G-3

表 1 TABLE 1

寸法区分 (mm) DIMENSION	公差 (mm) TOLERANCE
L ≤ 50	±1.5
50 < L ≤ 100	±2.5
100 < L ≤ 500	±3

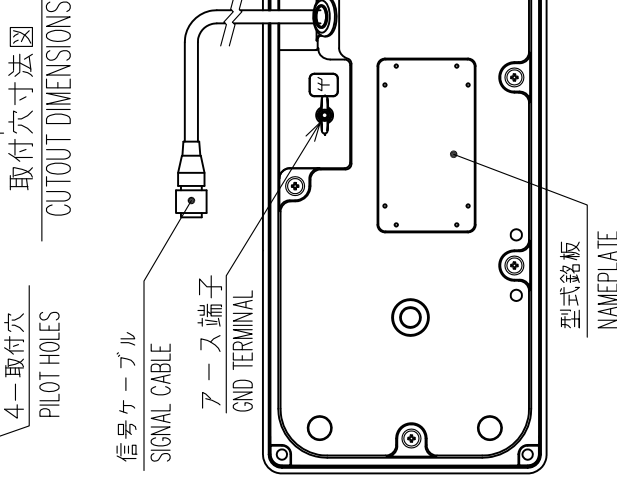
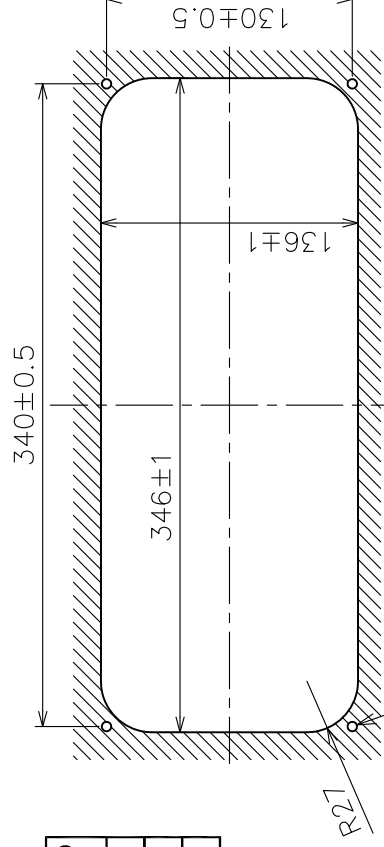
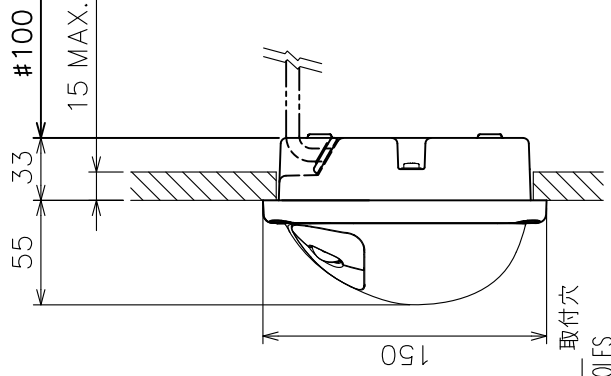
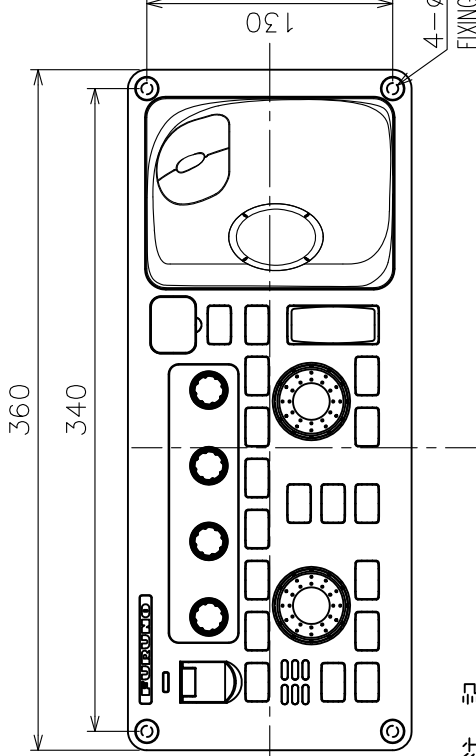
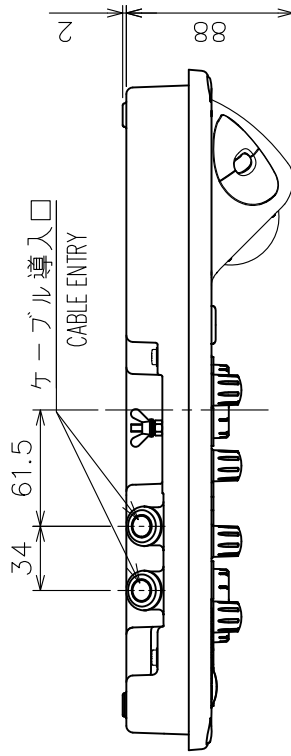

注 記

- 1) 指定外の寸法公差は表 1 による。
- 2) # 印寸法は最小サービス空間寸法とする。
- 3) 取付には + バインドットピンネジ呼び径 5 × 2.0 を使用のこと。
- 4) 質量は制御部に接続する信号ケーブル (5m) を含む。

NOTE

1. TABLE 1 INDICATES TOLERANCE OF DIMENSIONS WHICH IS NOT SPECIFIED.
2. # MINIMUM SERVICE CLEARANCE.
3. USE +BINDING TAPPING SCREWS $\phi 5 \times 2.0$ FOR FIXING THE UNIT.
4. MASS INCLUDES SIGNAL CABLE (5m) TO CONNECT PROCESSOR UNIT.

DRAWN	15/Nov/2011	T.YAMASAKI	TITLE	RCU-021
CHECKED	15/Nov/2011	H.MAKI	名称	操作部 (埋込装備)
APPROVED	17/Nov/2011	Y.NISHIYAMA	外寸図	
SCALE	1/4	MASS 2.5 kg	NAME	CONTROL UNIT (FLUSH MOUNT)
DWG.No.	C3584-G02-C	REF.No.	03-177-200G-0	OUTLINE DRAWING



表 1 TABLE 1

寸法区分 (mm) DIMENSION	公差 (mm) TOLERANCE
L ≤ 50	±1.5
50 < L ≤ 100	±2.5
100 < L ≤ 500	±3

- 注 記
- 1) 指定外の寸法公差は表 1 による
 - 2) #印寸法は最小ケーブルビス空間寸法とする
 - 3) KB 取付金具への取付には M5 × 12 + バインドコネジを使用のこと。
 - 4) 取付には + バインドタッピングピンネジ呼び径 5 × 20 を使用のこと。
 - 5) 質量は制御部に接続する信号ケーブル (5m) および取付金具を含む。

NOTE

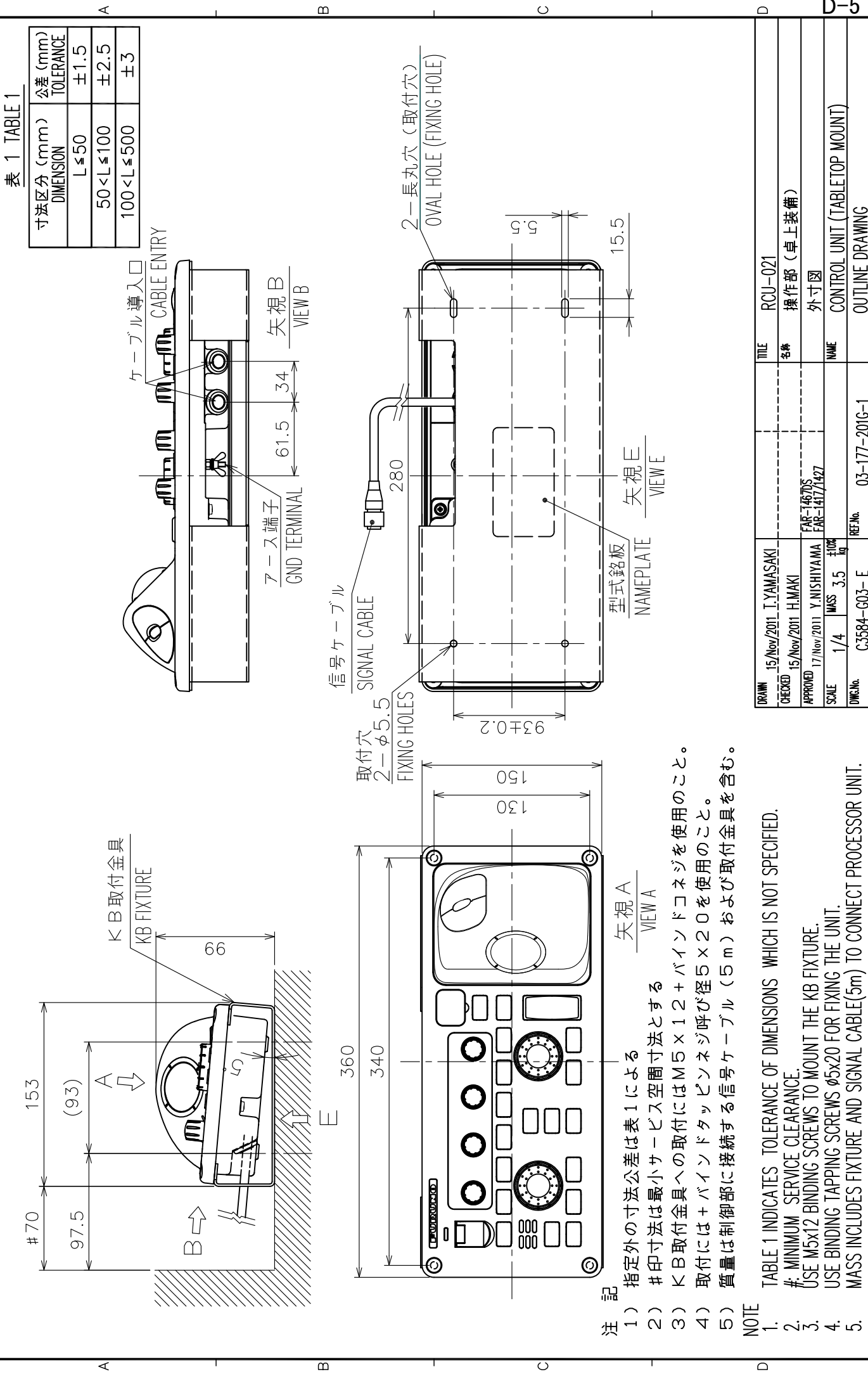
1. TABLE 1 INDICATES TOLERANCE OF DIMENSIONS WHICH IS NOT SPECIFIED.
2. # MINIMUM SERVICE CLEARANCE.
3. USE M5x12 BINDING SCREWS TO MOUNT THE KB FIXTURE.
4. USE BINDING TAPPING SCREWS φ5x20 FOR FIXING THE UNIT.
5. MASS INCLUDES FIXTURE AND SIGNAL CABLE(5m) TO CONNECT PROCESSOR UNIT.

DRAWN	15/Nov/2011	T.YAMASAKI	TITLE	RCU-021
CHECKED	15/Nov/2011	H.MAKI	名*	操作部 (卓上装備)
APPROVED	17/Nov/2011	Y.NISHIYAMA	外寸図	
SCALE	1/4	MASS 3.5 kg	NAME	CONTROL UNIT (TABLETOP MOUNT)
DWG.No.	C3584-G03-E	REF.No.	03-177-201G-1	OUTLINE DRAWING

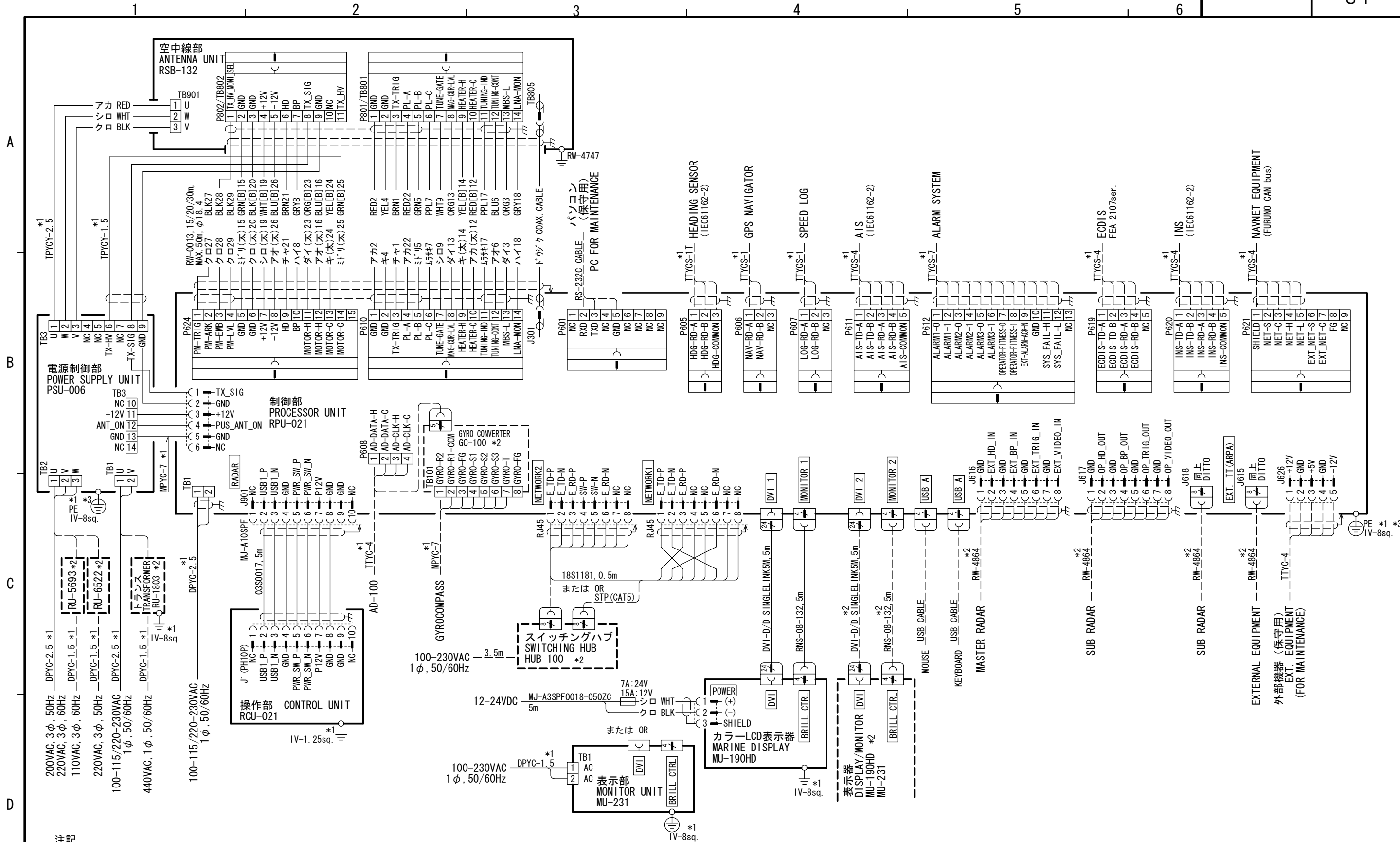

注記
 * 1) 造船所手配。
 * 2) オプション。
 * 3) 保護アース用ケーブルは黄/緑の絶縁線を使用のこと。

NOTE
 *1: SHIPYARD SUPPLY.
 *2: OPTION.
 *3: USE YEL/GRN WIRE FOR PROTECTIVE EARTH.

DRAWN 19/Dec/2011 T. YAMASAKI	TITLE FAR-1467DS
CHECKED 19/Dec/2011 H. MAKI	名称 船船用レーダー
APPROVED 20/Dec/2011 Y. NISHIYAMA	相互結線図
SCALE MASS kg	NAME MARINE RADAR
DWG No. C3612-C01-B	REF. No. 03-180-6001-4
INTERCONNECTION DIAGRAM	