

Test Report

(FCC Rules 47 CFR,
2.1046, 2.1047, 2.1049, 2.1051, 2.1053, 2.1055, and 80.217)

For

**Trade name: Furuno
Model: Transceiver for Marine Radar
Type: RTR-109**

Report no.: FLI 12-14-103

Date of issue: 18 December 2014

Furuno Labotech International Co., Ltd.

1-16, Fukazu-cho, Nishinomiya-shi, Hyogo, 663-8203 Japan

Tel: +81-798-63-1094 Fax: +81-798-63-1098

Report Summary

FLI project number:	FLI 04-14 -0464		
Test report number of initial issue:	FLI 12-14-103	Date of initial issue	18 December 2014
Test report number of revised/replaced issue:	---	Date of revised/replaced issue	---
Test report revision/ replacement history:	---		
Test standard(s)/ Test specifications:	FCC Rules 47 CFR, Sections: 2.1046 - RF Power Output, 2.1047 - Modulation Characteristics, 2.1049 - Occupied Bandwidth, 2.1051 - Spurious Emissions at Antenna Terminals, 2.1053 - Field Strength of Spurious Radiation, 2.1055 - Frequency Stability, 80.217 - Suppression of Interference Aboard Ships. (Date of issue: 1 October 2013)		
Customer:	Furuno Electric Co., Ltd. 9-52 Ashihara-Cho, Nishinomiya-City, 662-8580 Japan		
Manufacturer:	Furuno Electric Co., Ltd. 9-52 Ashihara-Cho, Nishinomiya-City, 662-8580 Japan		
Trade name:	FURUNO		
Model:	Transceiver for Marine Radar		
Type:	RTR-109		
Product function and intended use:	For marine safety navigation		
Number of samples tested:	One		
Serial number:	R00008-000002		
Power rating:	100 - 230 VAC, 6.4 - 2.7 A (via Power supply unit, PSU-015)		
Product status:	Pre-production model		
Modifications made to samples during testing:	None.		
Date of receipt of samples:	1 September 2014		
Test period:	From 10 September 2014 to 27 October 2014		
Place of test:	Furuno Labotech International Co., Ltd. - Nishinomiya Lab. 9-52, Ashihara-cho, Nishinomiya-shi, Hyogo, 662-8580 Japan - LABOTECH EMC Center 1-16, Fukazu-cho, Nishinomiya-shi, Hyogo, 663-8203 Japan (File number: 818191) Anechoic Chamber used for the test has been registered by FCC. Test firm Designation Number: JP2007, Test firm Registration #: 838049		
Test results/ Compliance:	Passed. The test results of this report relate only to the samples tested.		
Tested by:	Koji Kawai		
Written by:	Akiko Inoue		
Verified by:	Yoshihiro Ishii		
Approved by:	Date: 18 December 2014 Name: Yoshihiro Ishii Title: Senior Manager, Technical Department Signature: 		

Testing Laboratory Status

Furuno Labotech International Co., Ltd. (hereafter called "FLI") has been holding the following status after having been assessed according to the provisions of ISO/IEC 17025 and/or the relevant rules:

(1) JAB Accredited Testing Laboratory:

- accredited by Japan Accreditation Board (JAB),
- Laboratory accreditation number: RTL03220
- Date of initial accreditation: 14 January 2011
- Scope of accreditation: Electrical testing - EMC testing (*)

(2) Telefication Listed Testing Laboratory:

- listed by Telefication B. V., (The Netherlands)
- Laboratory assignment number: L116
- Date of initial listing: 26 July 1999 (*)
- for testing the following product categories/ test standards: EN 60945, IEC 61162-1/-2, IEC/EN 61162-450, and IEC 62288

(3) BSH Recognized Testing Laboratory:

- recognized by Bundesamt für Seeschifffahrt und Hydrographie (BSH), (Germany)
- Recognition certificate number: BSH/4613/06202/1864/11
- Date of initial recognition: 4 April 2003 (*)
- for testing the following product categories/ test standards: IEC/EN 60945, IEC 62388, IEC 61162-1/-2, and IEC 62288

(4) TÜV Appointed EMC Test Laboratory:

- appointed by TÜV Rheinland Japan Ltd.,
- Laboratory assignment number: UA 50046428
- Date of initial appointment: 21 December 1998 (*)
- for carrying out the tests of: - EN 55011, CISPR 11, EN 55022, CISPR 22, EN 55024, CISPR 24, EN 55025, CISPR 25, EN/IEC 61000-3-2/-3, EN/IEC 61000-4-2/-3/-4/-5/-6/-8/-11, EN/IEC 61000-6-1/-2/-3/-4, EN/IEC 60945, EN/IEC 61326-1, EN/IEC 61326-2-6, EN/IEC 60601-1-2, JIS T 0601-1-2, JIS C 1806-1, and ISO 11452-1/-2/-4.

(5) RMRS Recognized Testing Laboratory:

- recognized by Russian Maritime Register of Shipping (RMRS), (Russia)
- Laboratory recognition number: 11.02594.011
- Date of initial recognition: 27 January 2009 (*)
- for carrying out testing in the field of: Electrical measurements and tests, EMC tests, Mechanical measurements and tests, Equipment protection degree tests, and Climatic tests for Ship's radio and navigational equipment and IEC 60945: 2002

(6) RRR Recognized Test Laboratory:

- recognized by Russian River Register (RRR), (Russia)
- Recognition certificate number: 154262
- Date of initial recognition: 31 May 2013
- for carrying out of tests of ships radio and navigation equipment

(7) DNV Recognized Environmental Test Laboratory:

- recognized by Det Norske Veritas AS (DNV), (Norway)
- Recognition certificate number: 262.1-015854-J-12
- Date of initial recognition: 12 July 2013
- Scope of recognition: Testing according to the standards IEC 60945, IEC 61162-1/-2/-450, IEC 62288, IEC 62388 and IEC 62252 Annex E
- Application: Provisions of Environmental, interface and safety testing.

(8) CCS Recognized Test Agency :

- recognized by China Classification Society
- Recognition certificate number : DB13A00001
- Date of initial recognition : 29 January 2014
- Scope of recognition : Performance/Environmental/EMC/Special purpose/Safety precautions tests for Electrical & Electronic Product including Maritime Navigation and Radio-communication Equipment & Systems

Note: (*) – The current certificates may be found in the FLI web site (<http://www.furuno-labotech.co.jp>).

TABLE OF CONTENTS

Report Summary	2
Testing Laboratory Status	3
1 Principal Information	5
1.1 Equipment under test (EUT)	5
1.2 Observation and comments	7
2 Test Results Summary	8
3 Test Results	9
3.1 RF Power Output (FCC Rule 47 CFR, 2.1046)	9
3.2 Modulation Characteristics (FCC Rule 47 CFR, 2.1047)	9
3.3 Occupied Bandwidth (FCC Rule 47 CFR, 2.1049)	10
3.4 Frequency Stability (FCC Rule 47 CFR, 2.1055)	10
3.5 Spurious Emissions	11
3.5.1 Spurious Emissions at Antenna Terminal (FCC Rule 47 CFR, 2.1051)	11
3.5.2 Field Strength of Spurious Radiation (FCC Rule 47 CFR, 2.1053)	12
3.6 Suppression of Interference Aboard Ships (FCC Rule 47 CFR, 80.217)	13
4 Test Setup for Measurements	15
5 Measuring Equipment List	17
6 Photograph of Test Setup/Arrangement	19
7 RF Envelope and Spectrum of the output pulse	21
8 Spurious Emission Plots measured at Antenna Terminal	28
9 Field Strength Plots of Spurious Radiation	32
10 Field Strength Plots for Suppression of Interference Aboard Ships	40

1 Principal Information

1.1 Equipment under test (EUT)

1.1.1 General

- (a) Trade name: Furuno
- (b) Manufacturer: Furuno Electric Co., Ltd.
Ashihara-cho 9-52, Nishinomiya-city, 662-8580 Japan
- (c) Model:

	Type	Serial number	Note
Transceiver Unit	RTR-109	R00008-000002	
Scanner Unit	RSB-131	R00007-000001	Antenna rotation rate: 24/42 rpm
Antenna	SN36CF	---	

- (d) FCC ID: ADB9ZWRTR109
- (e) Primary Function: Search, Navigation and Anti-collision
- (f) Frequency Range: Fixed frequency, S-band (3050 MHz)
Type of Emission: P0N
(Emission designator)
- (g) Size and mass: Scanner Unit: 3810 (W) x 769 (H) x 640 (D) (mm), 126.0 kg
(with Antenna installed on)
Transceiver Unit: 606 (W) x 576 (H) x 313 (D) (mm), 22.0 kg
- (h) Power Supply: 48 VDC
(fed through the specified external equipment, not directly from DC mains)

1.1.2 Transceiver

Type: RTR-109

1.1.2.1 Transmitter

- (a) Assignable Frequency for Shipborne Radar:
Between 2900 MHz and 3100 MHz (for S-band radars) (FCC Rule, 80.375
(d)-(1))
- (a) Type of RF Generator:
Magnetron Type: MG5223F
Peak Output Power: 30 kW nominal
- (b) Magnetron Ratings:
Center frequency of Magnetron: 3050 MHz
Tolerances:
Manufacturing: ± 30 MHz
Pulling: 25 MHz
Tolerance for 20°C temperature variation: -5 MHz
- (c) Pulse Characteristics:

Pulse type	S1	S2	M1	M2	M3	L1	L2
Pulse length (μs)	0.07	0.15	0.30	0.50	0.70	1.20	1.20
P.R.F.(Hz)	3000	3000	1500	1200	1000	600	500

1.1.2.2 Modulator

- (a) FET Type: 2SK4207
Trigger Voltage: Approx. +20 VDC positive

1.1.2.3 Receiver

- (a) Passband

RF Stage: 60 MHz

IF Stage:

Pulse type	S1	S2	M1	M2	M3	L1	L2
Passband (MHz)	20.0	10.0	10.0	4.0	4.0	1.7	1.7

- (b) Intermediate Frequency: 60 MHz
- (c) Gain (overall): approximately 100 dB
- (d) Overall Noise Figure: 4.0 dB (typical)
- (e) Video Output Voltage: Not Provided (by LAN communication)
- (f) Features Provided: Sensitivity Time Controls (Anti-clutter Sea),
Fast Time Constant (Anti-clutter Rain)
- (g) If receiver is tunable, describe method for adjusting frequency:
by adjustment of tuning voltage of receiver local oscillator
(Automatic and manual)

1.1.3 Antenna and Scanner

- (a) Antenna Rotation ON-OFF Switch: Provided.
- (b) Construction: Slotted array antenna
- (c) Length:

Antenna type	SN36CF
Length (cm)	383 (12 ft.)

- (d) Type of Beam: Vertical fan
- (e) Beam Width (3 dB):

Antenna type	SN36CF
Horizontal (°)	1.8
Vertical (°)	25

(f) Polarization: Horizontal

(g) Antenna Gain:

Antenna type	SN36CF
Gain (dBi)	26.8

(h) Attenuation of Major Side Lobes with respect to main beam:

Antenna type	SN36CF
Within $\pm 10^\circ$ (dB)	-24
Outside $\pm 10^\circ$ (dB)	-30

(i) Scanning (rotating or oscillating): Rotating over 360° continuously clockwise

(j) Antenna Rotation Rate: 24/42 rpm

(k) Sector Scan: Provided.

(l) Rated Loss of Transmission line per hundred feet: Below 2.9 dB

1.1.4 Operational Features

(a) Is positive means provided to indicate whether or not the overall operation of the equipment is such that it may be relied upon to provide effective operation in accordance with its primary function:

Yes (Receiver tuning indicator)

(b) Is the equipment for continuous operation: Yes

(c) Is provision made for operation with shore based radar beacons (RACONS):

Yes (RACONS)

1.1.5 Construction Features

(a) Does equipment embody replacement units with chassis type assembly: Yes

(b) Are fuse alarms provided: No

(c) State units that are weatherproof: Scanner Unit (IEC 60529 – IPX6)

(d) If all units are not housed in a single container, indicate number and give description of individual units: See Clause 1.1.1 (c) of this report.

(e) Approximate space required for installation excluding scanner: not applicable.

1.2 Observation and comments

None.

2 Test Results Summary

Clause no. of this report	47 CFR Section	Item	Result	Test Engineer
3.1	2.1046	RF Power Output	Passed.	K. Kawai
3.2	2.1047	Modulation Characteristics	Passed.	K. Kawai
3.3	2.1049	Occupied Bandwidth	Passed.	K. Kawai
3.4	2.1055	Frequency Stability	Passed.	K. Kawai
3.5		Spurious Emissions	---	
3.5.1	2.1051	- Spurious Emissions at Antenna Terminal	Passed.	K. Kawai
3.5.2	2.1053	- Field Strength of Spurious Radiation	Passed.	K. Kawai
3.6	80.217	Suppression of Interference Aboard Ships	Passed.	K. Kawai

3 Test Results

3.1 RF Power Output (FCC Rule 47 CFR, 2.1046)

(1) Test conditions:

For all TX (S1/S2/M1/M2/M3/L1/L2) Pulses, the transmitter output power was measured at the antenna port with Antenna replaced with the Non-reflective load.

(2) Test setup:

See Clause 4.

(3) Test Results:

Pulse type	S1	S2	M1	M2	M3	L1	L2
Magnetron Output, mean P_m (W)	7.3	12.5	12.4	17.1	20.4	22.1	18.5
Magnetron Output, peak P_p (kW) (*1)	29.3	24.9	26.2	27.6	28.5	30.4	30.6
Pulselength T (μ s) (-3 dB points) (*2)	0.084	0.167	0.315	0.516	0.715	1.210	1.212
PRR (Hz)	3000	3000	1500	1200	1000	600	500

(*1) P_p (kW) = $(P_m$ (W) / (T (μ s) \times PRR (Hz))) \times 1000

(*2): Measured at -3 dB points of the RF envelope of the magnetron output pulse instead of at 50% points of the current of the magnetron, which are equivalent.

Environmental conditions observed: On 10 September 2014, 25°C to 25°C, 65% to 54%RH

Power supply voltage measured (*): 100.0 VAC, 60 Hz to 100.0 VAC, 60 Hz.

(*): Power input voltages to the external equipment (Power supply unit) measured.

3.2 Modulation Characteristics (FCC Rule 47 CFR, 2.1047)

(1) Test Conditions:

The RF envelope of the magnetron output pulse was measured using an envelope detector and an oscilloscope.

Each pulse spectrum was measured using a spectrum analyzer.

(2) Test setup:

See Clause 4.

(3) Limits (FCC Rule, 80.213 (g)/80.209(b)):

Upper limit frequency, $f(U) = f_0 + f(AUBW)/2 - 1.5/T$

Lower limit frequency, $f(L) = f_0 - f(AUBW)/2 + 1.5/T$

Note: Assigned frequency (f_0): 3050 MHz (for S-band radars)

Authorized bandwidth ($f(AUBW)$): 100 MHz (for S-band radars)

(4) Test Results:
Complied.

Pulse type	S1	S2	M1	M2	M3	L1	L2	Result
Pulselength T (μ s) (-3 dB points) (*1)	0.084	0.167	0.315	0.516	0.715	1.210	1.212	Not applicable.
Rise time t_r (μ s) (10 - 90 % amplitude)	0.013	0.012	0.160	0.158	0.200	0.226	0.234	Not applicable.
Decay time t_d (μ s) (90 - 10 % amplitude)	0.136	0.213	0.127	0.117	0.124	0.126	0.122	Not applicable.
PRR (Hz)	3000	3000	1500	1200	1000	600	500	Not applicable.
Guard Band $f(1.5/T)$ (MHz) (*2)	17.9	9.0	4.8	2.9	2.1	1.2	1.2	Not applicable.
$f(U)$ (MHz)	3082.1	3091.0	3095.2	3097.1	3097.9	3098.8	3098.8	Not applicable.
$f(L)$ (MHz)	3017.9	3009.0	3004.8	3002.9	3002.1	3001.2	3001.2	Not applicable.
Frequency at maximum emission (MHz)	3047.7	3047.7	3047.8	3047.5	3047.3	3046.9	3046.8	Complied.

(*1): Measured at -3 dB points of the RF envelope of the magnetron output pulse instead of at 50% points of the voltage/current of the magnetron, which are equivalent.

(*2): Guard Band is specified to be equal to $1.5/T$ MHz, where "T" is the pulselength in microseconds. (FCC Rule 47 CFR, 80.209(b))

Measured Plots: See Clause 7.

Environmental conditions observed: On 10 September 2014, 25°C to 25°C, 65% to 54%RH
Power supply voltage measured (*): 100.0 VAC, 60 Hz to 100.0 VAC, 60 Hz.

(*): Power input voltages to the external equipment (Power supply unit) measured.

3.3 Occupied Bandwidth (FCC Rule 47 CFR, 2.1049)

(1) Test conditions:

For all TX (S1/S2/M1/M2/M3/L1/L2) Pulses, the transmitter occupied bandwidth was measured at the antenna port with Antenna replaced with the Non-reflective load.

(2) Test setup:

See Clause 4.

(3) Test Results:

Pulse type	S1	S2	M1	M2	M3	L1	L2
Occupied bandwidth (MHz)	51.7	40.8	28.3	16.7	11.7	6.7	6.7

Spectrum plots: See Clause 7.

Environmental conditions observed: On 10 September 2014, 25°C to 25°C, 65% to 54%RH
Power supply voltage measured (*): 100.0 VAC, 60 Hz to 100.0 VAC, 60 Hz.

(*): Power input voltages to the external equipment (Power supply unit) measured.

3.4 Frequency Stability (FCC Rule 47 CFR, 2.1055)

(1) Test Conditions:

- (1) Radar Transmitter settings: All TX (S1/S2/M1/M2/M3/L1/L2) Pulses
- (2) Ambient Temperature settings: - 30°C to + 50°C (10°C interval)
- (3) Power Supply Voltage settings: 85/100/115 % of nominal voltage (85.0/100.0/115.0 VAC)

(2) Test setup:

See Clause 4.

(3) Frequency Tolerance Limits (FCC Rule 47 CFR, 80.209(b)):

Pulse type	S1	S2	M1	M2	M3	L1	L2
f(U) (MHz)	3082.1	3091.0	3095.2	3097.1	3097.9	3098.8	3098.8
f(L) (MHz)	3017.9	3009.0	3004.8	3002.9	3002.1	3001.2	3001.2

See Clause 3.2 for details.

(4) Test Results:

Complied.

Power Supply Voltage setting (*): 85.0 VAC, 60 Hz

Pulse type		S1	S2	M1	M2	M3	L1	L2	Result
Frequency at maximum emission (MHz)	-30°C	3049.5	3049.9	3049.8	3049.7	3049.5	3049.1	3049.0	Complied.
	-20°C	3049.3	3049.6	3049.7	3049.4	3049.2	3048.8	3048.6	Complied.
	-10°C	3048.2	3049.3	3049.3	3049.0	3048.7	3048.2	3048.2	Complied.
	0°C	3048.3	3049.0	3048.8	3048.6	3048.1	3047.8	3047.8	Complied.
	+10°C	3048.0	3048.0	3048.0	3047.9	3047.6	3047.3	3047.2	Complied.
	+20°C	3047.3	3047.7	3047.7	3047.5	3047.2	3046.9	3046.8	Complied.
	+30°C	3046.6	3047.0	3047.1	3047.0	3046.4	3046.0	3046.1	Complied.
	+40°C	3046.1	3046.2	3046.4	3046.2	3046.2	3045.7	3045.8	Complied.
	+50°C	3045.3	3045.8	3045.9	3045.9	3045.6	3045.2	3045.1	Complied.

Power Supply Voltage setting (*): 100.0 VAC, 60 Hz

Pulse type		S1	S2	M1	M2	M3	L1	L2	Result
Frequency at maximum emission (MHz)	-30°C	3049.7	3049.8	3049.9	3049.8	3049.4	3049.1	3049.0	Complied.
	-20°C	3049.3	3049.4	3049.9	3049.4	3049.1	3048.7	3048.7	Complied.
	-10°C	3048.5	3049.2	3049.4	3049.0	3048.6	3048.2	3048.1	Complied.
	0°C	3048.1	3048.7	3048.7	3048.6	3048.3	3047.8	3047.7	Complied.
	+10°C	3047.8	3048.2	3048.2	3047.9	3047.7	3047.2	3047.3	Complied.
	+20°C	3047.7	3047.7	3047.8	3047.5	3047.3	3046.9	3046.8	Complied.
	+30°C	3046.6	3047.0	3047.0	3046.7	3046.5	3046.1	3046.1	Complied.
	+40°C	3045.9	3046.4	3046.4	3046.4	3046.2	3045.7	3045.8	Complied.
	+50°C	3045.7	3045.8	3046.0	3045.7	3045.7	3045.3	3045.2	Complied.

Power Supply Voltage setting (*): 115.0 VAC, 60 Hz

Pulse type		S1	S2	M1	M2	M3	L1	L2	Result
Frequency at maximum emission (MHz)	-30°C	3049.5	3049.8	3049.9	3049.8	3049.5	3049.2	3049.1	Complied.
	-20°C	3049.3	3049.6	3049.5	3049.8	3049.4	3048.7	3048.6	Complied.
	-10°C	3048.5	3049.5	3049.1	3048.9	3048.7	3048.2	3048.1	Complied.
	0°C	3048.1	3049.0	3048.6	3048.5	3048.3	3047.8	3047.7	Complied.
	+10°C	3047.8	3048.0	3048.2	3048.0	3047.7	3047.3	3047.3	Complied.
	+20°C	3047.3	3047.8	3047.8	3047.5	3047.2	3046.8	3046.7	Complied.
	+30°C	3046.3	3047.0	3046.9	3046.6	3046.5	3046.1	3046.1	Complied.
	+40°C	3045.9	3046.4	3046.4	3046.4	3046.1	3045.7	3045.7	Complied.
	+50°C	3045.3	3045.8	3046.0	3045.9	3045.7	3045.2	3045.2	Complied.

Environmental conditions observed: On 22 October 2014, 24°C to 24°C, 60% to 60%RH

On 23 October 2014, 25°C to 24°C, 54% to 60%RH

On 24 October 2014, 25°C to 25°C, 61% to 61%RH

On 27 October 2014, 25°C to 25°C, 61% to 61%RH

(*): Power input voltages to the external equipment (Power supply unit) measured.

3.5 Spurious Emissions

3.5.1 Spurious Emissions at Antenna Terminal (FCC Rule 47 CFR, 2.1051)

(1) Test Conditions:

For all TX (S1/S2/M1/M2/M3/L1/L2) Pulses, the transmitter output power will be measured at the antenna port with Antenna replaced with the Non-reflective load.

(2) Test setup:

See Clause 4.

(3) Emission Limits (FCC Rule 47 CFR, 80.211 (f)):

Frequency removed from the assigned frequency	Emission attenuation (mean power, dB)
50 - 100 % (of the authorized bandwidth)	At least 25
100 - 250 % (of the authorized bandwidth)	At least 35
more than 250 % (*) (of the authorized bandwidth)	At least 43 + 10 log ₁₀ (mean power in watts)

Note (1): Authorized bandwidth = 100 MHz (for S-band radars)

(*) - for the relevant frequency bands, tests were performed according to FCC Rule, 2.1053. See Clause 3.5.2.

(4) Test Results:

Complied.

Spectrum Plots: See Clause 8.

Environmental conditions observed: On 10 September 2014, 25°C to 25°C, 65% to 54%RH

Power supply voltage measured (*): 100.0 VAC, 60 Hz to 100.0 VAC, 60 Hz.

(*): Power input voltages to the external equipment (Power supply unit) measured.

3.5.2 Field Strength of Spurious Radiation (FCC Rule 47 CFR, 2.1053)

(1) Test Conditions:

For all TX (S1/S2/M1/M2/M3/L1/L2) Pulses, the Radiated Emission test was performed.

(a) For the test frequency range of 9 kHz to 2000 MHz, the Antenna for Transceiver was replaced with the rotating non-reflective load. Spurious emissions for 9 kHz to 2000 MHz are not found at the antenna terminal due to its structure (Waveguide tube). The EUT cabinet radiation was measured with the EUT rotated 360°.

(b) For 2 GHz to 40 GHz, the Antenna was set to the Transceiver with the rotating mode.

(2) Test Site: FLI EMC Center, Semi-Anechoic Chamber
(File number: 818191)

(3) Distance between the radar set and measuring antenna: 3 m

(4) Test setup:

For the test frequency range of 2 GHz to 40 GHz, the GRP (Ground reference plane, metal floor) between the EUT and the measuring (receiving) antenna was lined with the Radio Absorbers (3.0 m × 3.6 m × 0.3 m) to reduce the influences of the reflections of the RF waves from the floor.

Measuring (Receiving) Antenna height and polarization:

(a1) 1.5 m for the test frequency range of 9 kHz to 30 MHz,

(a2) 1 m to 4 m for the test frequency range of 30 MHz to 2000 MHz,

(b) 1.5 m that was same as those for the EUT for the test frequency range of 2 GHz to 40 GHz.

(c) Antenna polarization: vertical and horizontal.

EUT height:

(a) 0.8 m for the test frequency range of 9 kHz to 2000 MHz,

(b) 0.8 m for the test frequency range of 2 GHz to 40 GHz.

See Clauses 4 and 6.

(5) Field Strength Limits (FCC Rule 47 CFR, 80.211 (f)):

Frequency removed from the assigned frequency	Emission attenuation (mean power, dB)
50 - 100 % (*) (of the authorized bandwidth)	At least 25
100 - 250 % (*) (of the authorized bandwidth)	At least 35
more than 250 % (of the authorized bandwidth)	At least 43 + 10 log ₁₀ (mean power in watts)

Note (1): Assigned frequency (center frequency) = 3050 MHz (for S-band radars)

(2): Authorized bandwidth = 100 MHz (for S-band radars)

(*) - for the relevant frequency bands, tests were performed according to FCC Rule 47 CFR, 2.1051. See Clause 3.5.1.

(6) Test Results:

Complied.

From the results of the pre-tests, the spurious emission level was found to be the maximum with S1 pulse. Consequently, the test was performed only with S1 pulse.

$$\begin{aligned}
 [\text{Limit}] &= 43 + 10 \log_{10} (\text{mean power in watts}) \\
 &= 43 + 10 \log_{10} (7.3) \\
 &= 51.6 \text{ dB}
 \end{aligned}$$

where, [mean power in watts] = 7.3 W for S1 pulse. See 3.1.

For this time, Limit of 60 dB was applied for the test.

From the results of the pre-tests, the spurious emission level was found to be the maximum with S1 pulse. Consequently, the final test was performed only with S1 pulse.

The electric field strength of the maximum power radiation was 166.5 dB μ V/m with S1 pulse. Consequently, the allowable emission limit was set to 106.5 dB μ V/m (= 166.5 dB μ V/m - 60 dB).

Spectrum plots: See Clause 9.

Spurious Emission Frequency and Electric Field Strength that were prominent were listed in the following table. Spurious Emission Frequency and Electric Field Strength of which the limit margin was less than 20 dB are listed in the following table.

Frequency (GHz)	Antenna Polarization	Pulse type	Electric Field Strength measured (dB μ V/m)	Limit (dB μ V/m)	Margin (dB)
6.08	Horizontal	S1	103.2	106.5	3.3
6.08	Vertical	S1	102.9	106.5	3.6
9.13	Horizontal	S1	96.1	106.5	10.4

Environmental conditions observed: On 2 October 2014, 25°C to 24°C, 54% to 68%RH

Power supply voltage measured (*): 100.0 VAC, 60 Hz to 100.0 VAC, 60 Hz.

(*): Power input voltages to the external equipment (Power supply unit) measured.

3.6 Suppression of Interference Aboard Ships (FCC Rule 47 CFR, 80.217)

(1) Test Conditions/Test Setup:

The test was performed at the antenna port with the Standby (Receive) mode.

(2) Test frequency range: 9 kHz to 40 GHz

(3) Spurious Emission Limits for Receivers:

Frequency	Power to artificial antenna (μ W)	Resolution bandwidth of Spectrum analyzer
9 kHz - 150 kHz	400	1 kHz
150 kHz - 30 MHz		10 kHz
30 MHz - 100 MHz	4,000	100 kHz
100 MHz - 300 MHz	40,000	
300 MHz - 1 GHz	400,000	
1 GHz - 40 GHz		1 MHz

(4) Test Results:

Complied.

Tests were performed with the EUT Standby mode (= receive only mode).

Spurious emission levels measured were found to be attenuated more than 20 dB below the limits.

Spectrum plots: See Clause 10.

Environmental conditions observed: On 10 September 2014, 25°C to 25°C, 65% to 54%RH

Power supply voltage measured (*): 100.0 VAC, 60 Hz to 100.0 VAC, 60 Hz.

(*): Power input voltages to the external equipment (Power supply unit) measured.

4 Test Setup for Measurements

(1) Test Setup for Clauses 3.1, 3.2, 3.3, 3.4, and 3.5.1.

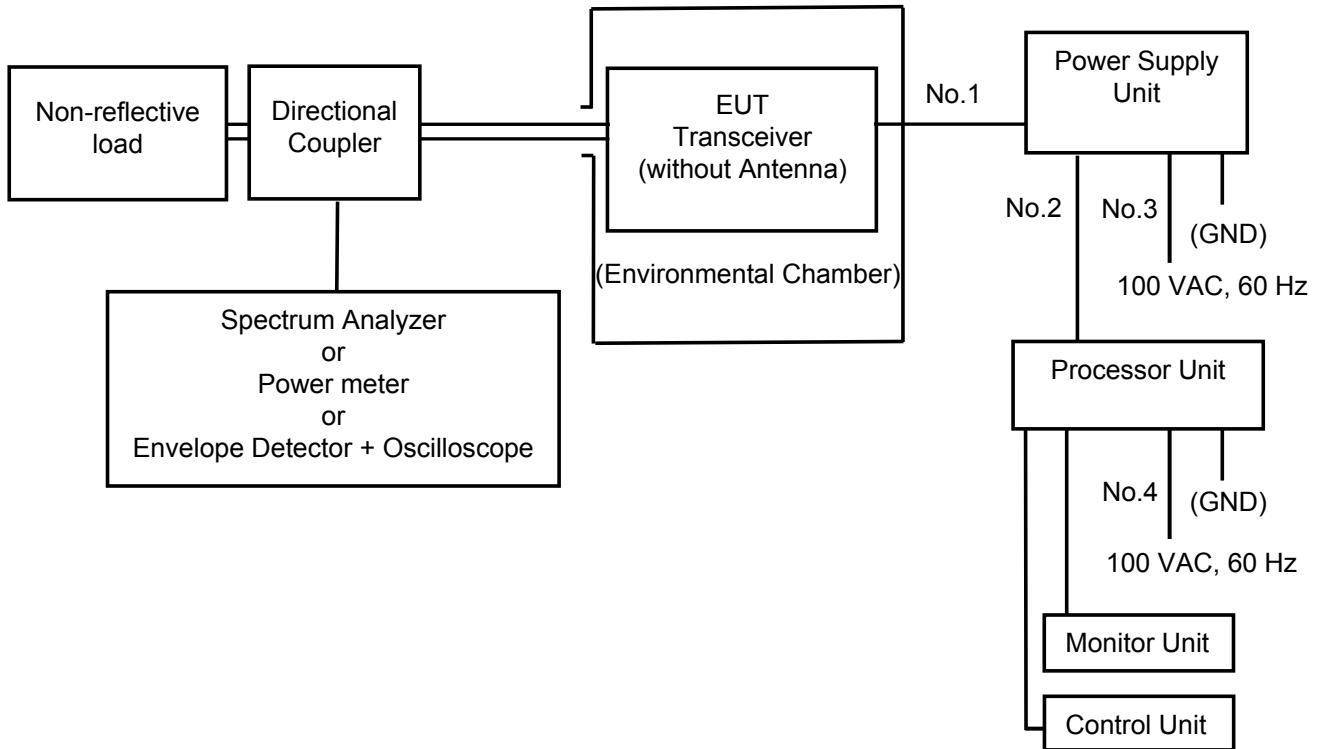

(2) Test Setup for Clause 3.5.2.

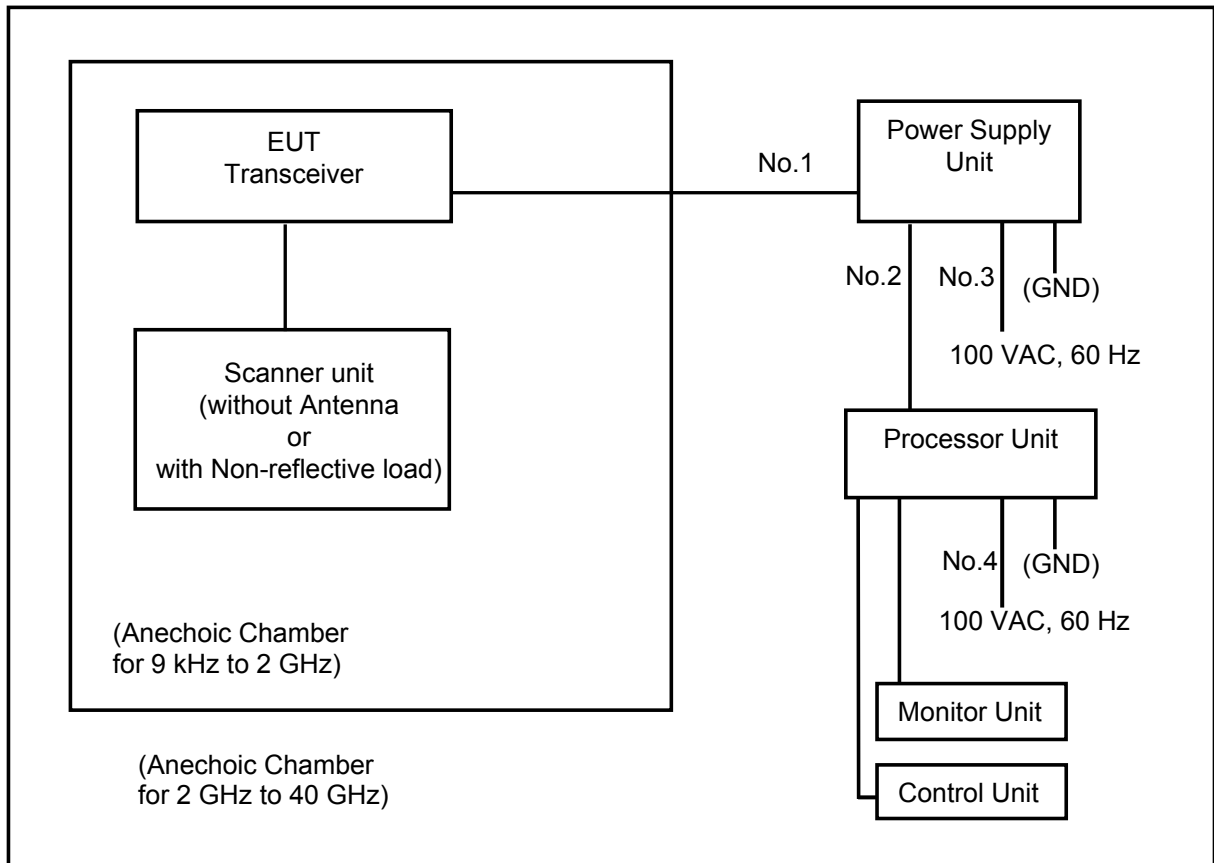

(3) Test Setup for Clause 3.6.

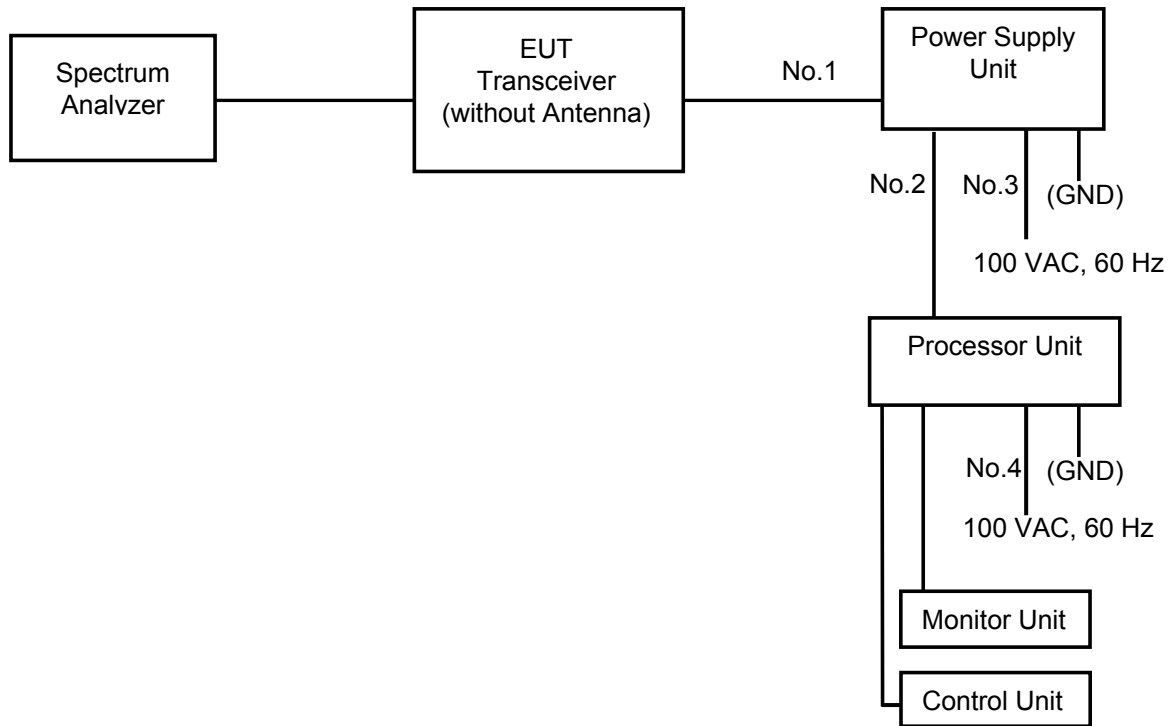

Cable designations:

No.	Name	Length (m)
1	RW-00135	15
2	CAT 5E	2
3	DPYC-2.5	3
4	IEC 60320-C13-L5M	5

5 Measuring Equipment List

(1) For 3.1 RF Power Output:

C/N	Instrument	Type	S/N	Manufacturer	Date of last calibration	Calibration interval
8408089	Power meter	436A	2410A19137	Agilent	14 November 2013	1 year
8408089	Power Sensor	8481A	2349A39603	Agilent	14 November 2013	1 year
7407008	Directional Coupler (S-band)	5D108	R1788	Shimada	9 April 2014	1 year
7407008	Dummy Load (S-band)	4D106	R18083	Shimada	9 April 2014	1 year
HT446	Programmable AC power supply	4420/4471	306043	NF	---	---

(2) For 3.2 Modulation Characteristics:

C/N	Instrument	Type	S/N	Manufacturer	Date of last calibration	Calibration interval
7407008	Directional Coupler (S-band)	5D108	R1788	Shimada	9 April 2014	1 year
7407008	Dummy Load (S-band)	4D106	R18083	Shimada	9 April 2014	1 year
HT654	Step Attenuator	8494B	MY42148134	Agilent	31 March 2014	1 year
HT655	Step Attenuator	8495B	MY42144403	Agilent	31 March 2014	1 year
HT913	Crystal Detector	423B	MY51340543	Agilent	27 February 2014	1 year
HT676	Spectrum Analyzer	8564EC	4103A00440	Agilent	11 April 2014	1 year
HT938	Frequency Counter	53181A	KR91200825	Agilent	8 January 2014	1 year
HT972	Oscilloscope	MSO4054B	C030483	Tektronix	6 May 2014	1 year
HT446	Programmable AC power supply	4420/4471	306043	NF	---	---

(3) For 3.3 Occupied Bandwidth and for 3.5.1 Spurious Emissions at Antenna Terminal:

C/N	Instrument	Type	S/N	Manufacturer	Date of last calibration	Calibration interval
7407008	Directional Coupler (S-band)	5D108	R1788	Shimada	9 April 2014	1 year
7407008	Dummy Load (S-band)	4D106	R18083	Shimada	9 April 2014	1 year
HT654	Step Attenuator	8494B	MY42148134	Agilent	31 March 2014	1 year
HT655	Step Attenuator	8495B	MY42144403	Agilent	31 March 2014	1 year
HT676	Spectrum Analyzer	8564EC	4103A00440	Agilent	11 April 2014	1 year
HT446	Programmable AC power supply	4420/4471	306043	NF	---	---

(4) For 3.4 Frequency Stability:

C/N	Instrument	Type	S/N	Manufacturer	Date of last calibration	Calibration interval
HT370	Climatic Chamber (Large)	TBE-3HW5GE2F	3013000995	Espec	18 August 2014	1 year
HT723	Paperless recorder/Dual communication logger DAQSTATION FX100	FX106-4-1	S5JA01445	Yokogawa	18 August 2014	1 year
7407008	Directional Coupler (S-band)	5D108	R1788	Shimada	9 April 2014	1 year
7407008	Dummy Load (S-band)	4D106	R18083	Shimada	9 April 2014	1 year
----	Waveguide (for S-band)	----	----	Furuno		
HT654	Step Attenuator	8494B	MY42148134	Agilent	31 March 2014	1 year
HT655	Step Attenuator	8495B	MY42144403	Agilent	31 March 2014	1 year
HT676	Spectrum Analyzer	8564EC	4103A00440	Agilent	11 April 2014	1 year
HT446	Programmable AC power supply	4420/4471	306043	NF	---	---

(5) For 3.5.2 Field Strength of Spurious Radiation:

C/N	Instrument	Type	S/N	Manufacturer	Date of last calibration	Calibration interval
HT676	Spectrum Analyzer	8564EC	4103A00440	Agilent	11 April 2014	1 year
HT744	Radiated emission measurement software	EP5/RE-AJ	Ver. 5.6.0	Toyo Corp.	---	---
HT745	EMI Test receiver (20 Hz - 40 GHz)	ESU40	100243	Rohde & Schwarz	28 December 2013	1 year
HT754	Pre-amp. (9 kHz - 1 GHz, Gain 32 dB)	310N	304877	Sonoma	7 July 2014	1 year
HT755	Pre-amp. (1 GHz - 8 GHz, Gain 40 dB)	TAP0108-40	1017	Toyo Corp.	7 July 2014	1 year
HT905	Magnetic Loop Antenna	HLA6120	34698	TESEQ	28 December 2013	1 year
HT788	Biconical antenna (30 MHz - 300 MHz)	BBA9106+ VHBB9124	9124-521	SCHWARZBECK	28 December 2013	1 year
HT789	Log Periodic antenna (300 MHz - 1 GHz)	3148B	00123951	ETS LINDGREN	28 December 2013	1 year
HT758	Broadband Horn antenna (1 GHz - 6 GHz)	BBHA9120B	522	Schwarzbeck	28 December 2013	1 year
HT467	Double-ridged waveguide horn antenna (1 GHz to 18 GHz)	3115	6520	EMCO	12 August 2014	1 year
HT761	Double rigged horn antenna & amp.	HAP18-26N	00000017	TOYO	28 December 2013	1 year
HT762	Double rigged horn antenna & amp.	HAP26-40N	00000010	TOYO	28 December 2013	1 year
HT779	Semi-Anechoic chamber	10mAC	90984	TOKIN	---	---
HT780	Programmable AC/DC Power Supply	ES18000W	9128767-1+9 128767-2	NF	---	---
30-0022	Notch Filter (S-band)	CBR-S7-3A	R1189001	Shimada	17 September 2014	1 year
0805028-000	COAXIAL DUMMY	TF300-A	85D11	SANKEN	---	---
KB137	Coaxial cable	MWX221-2m	0804S167	JUNKOSHA	19 September 2014	1 year
KB138	Coaxial cable	MWX221-5m	0804S166	JUNKOSHA	19 September 2014	1 year
KB179	Coaxial Cable for Radiated Emission Measurement	SUCOFLEX 104A	48932/4A	HUBER+SUHNER	9 August 2014	1 year
KB180	Coaxial Cable for Radiated Emission Measurement	SUCOFLEX 104A	48933/4A	HUBER+SUHNER	9 August 2014	1 year
KB181	Coaxial Cable for Radiated Emission Measurement	SUCOFLEX 102A	1261/2A	HUBER+SUHNER	9 August 2014	1 year

(6) For 3.6 Suppression of Interference Aboard Ships:

C/N	Instrument	Type	S/N	Manufacturer	Date of last calibration	Calibration interval
HT676	Spectrum Analyzer	8564EC	4103A00440	Agilent	11 April 2014	1 year
HT446	Programmable AC power supply	4420/4471	306043	NF	---	---

6 Photograph of Test Setup/Arrangement

(1) For Temperature (TX frequency stability) tests,



(2) For Spurious Emission measurements,

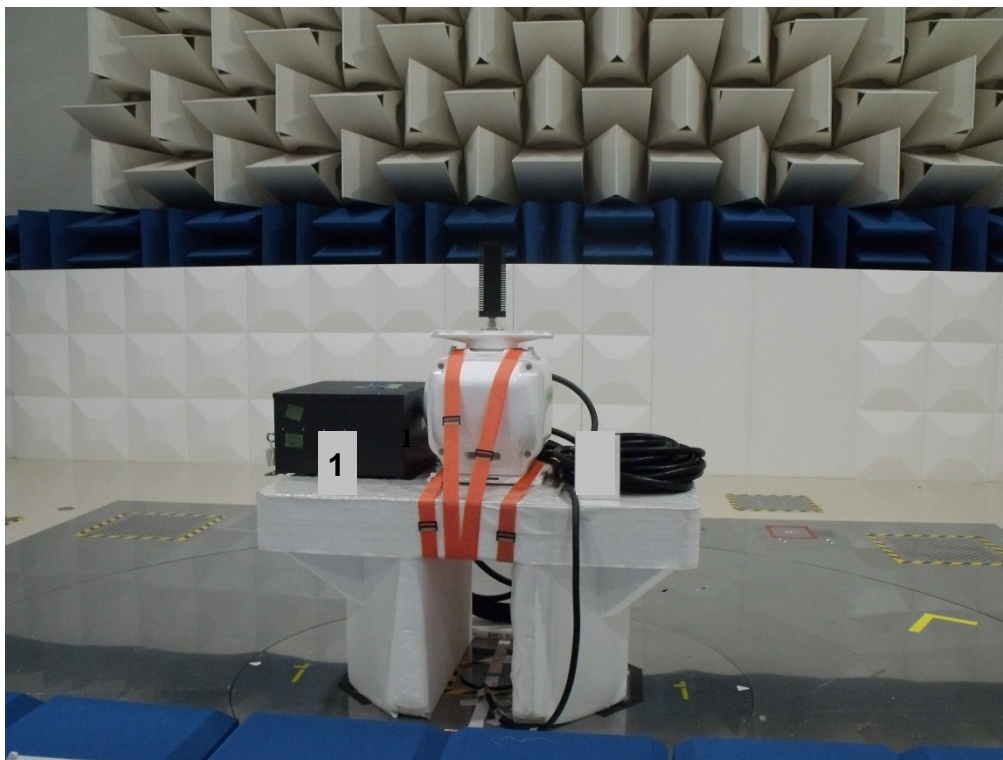

for 9 kHz to 2000 MHz

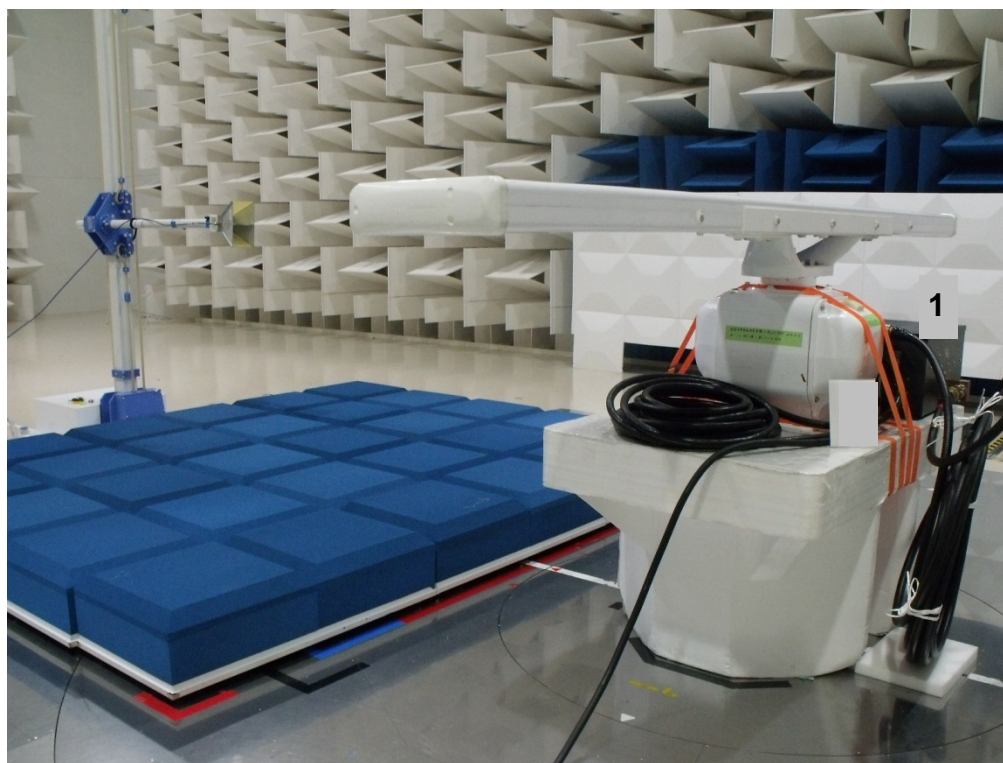

for 2 GHz to 40 GHz

7 RF Envelope and Spectrum of the output pulse

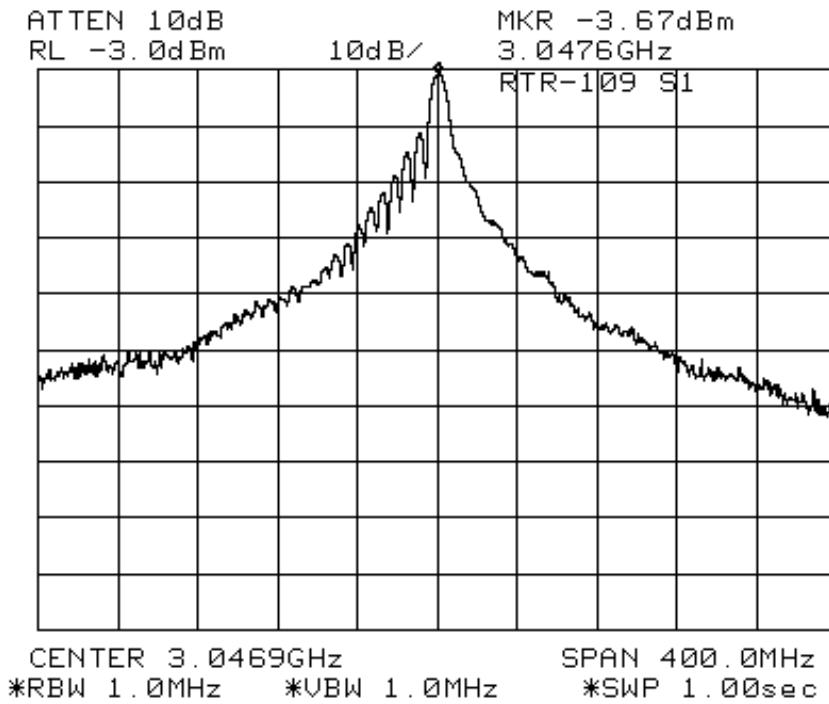
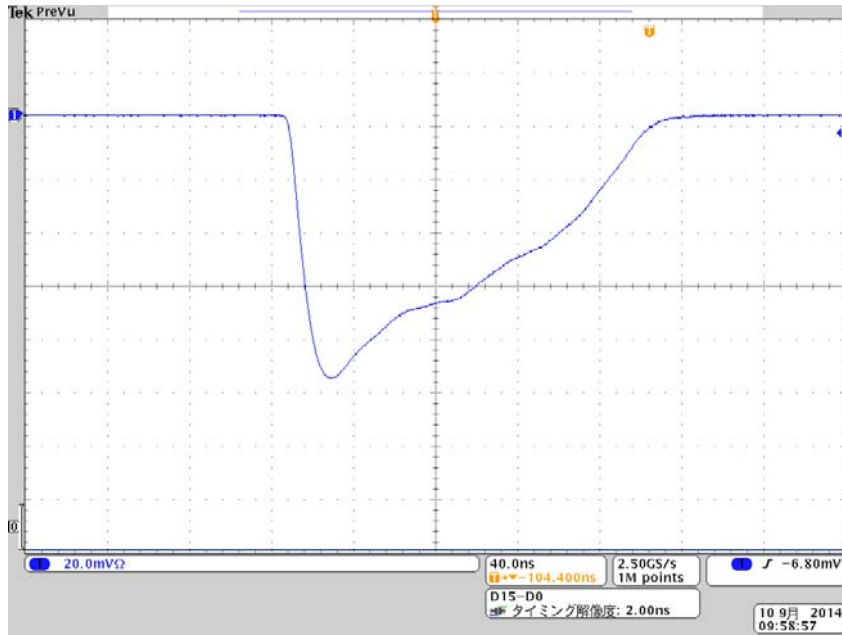

Fig. 7.1 S1 Pulse Envelope and Spectrum

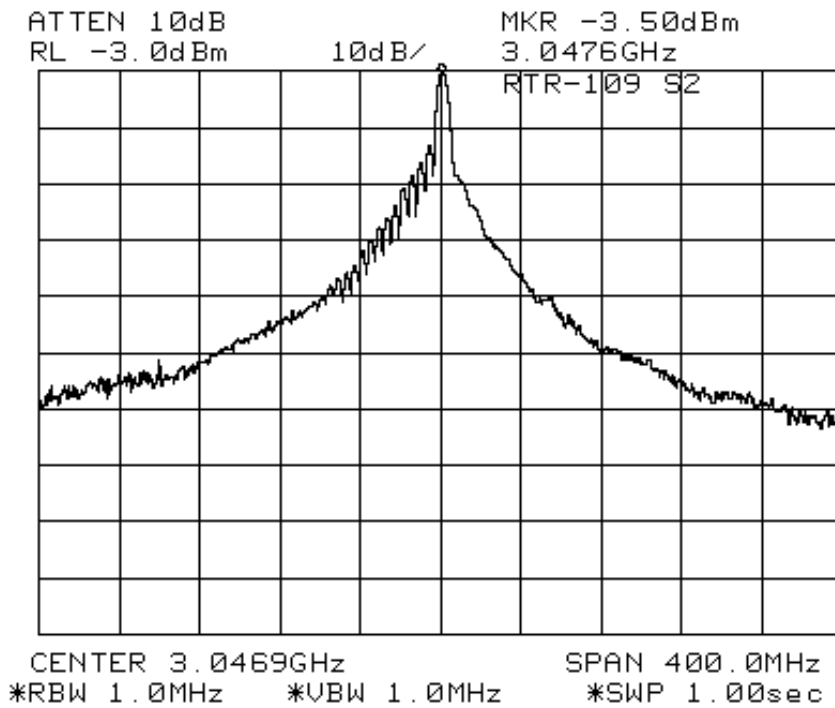
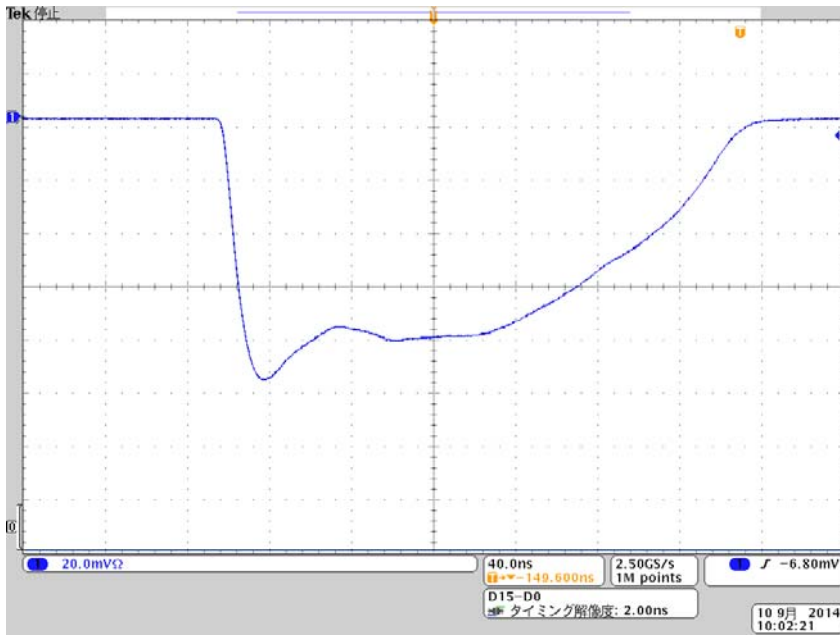

Fig. 7.2 S2 Pulse Envelope and Spectrum

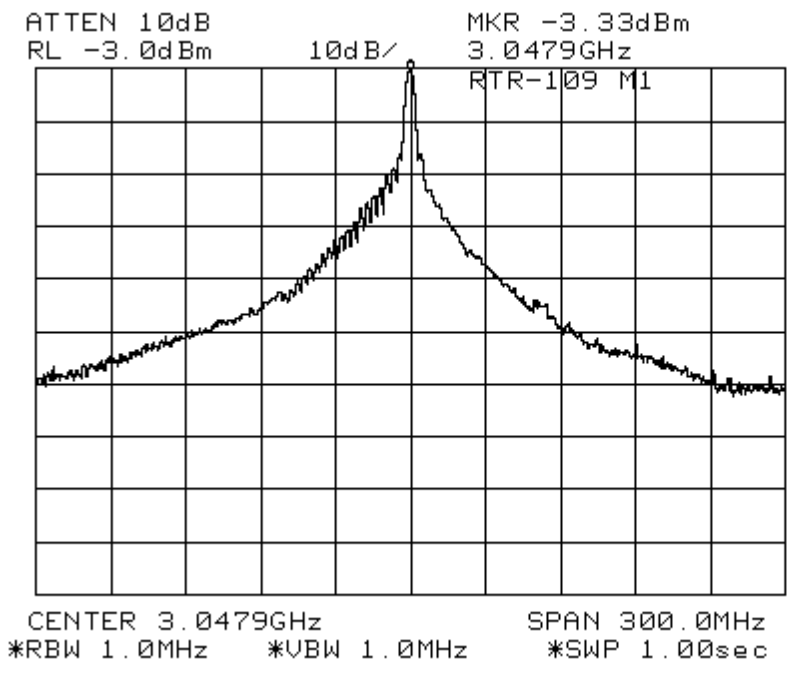
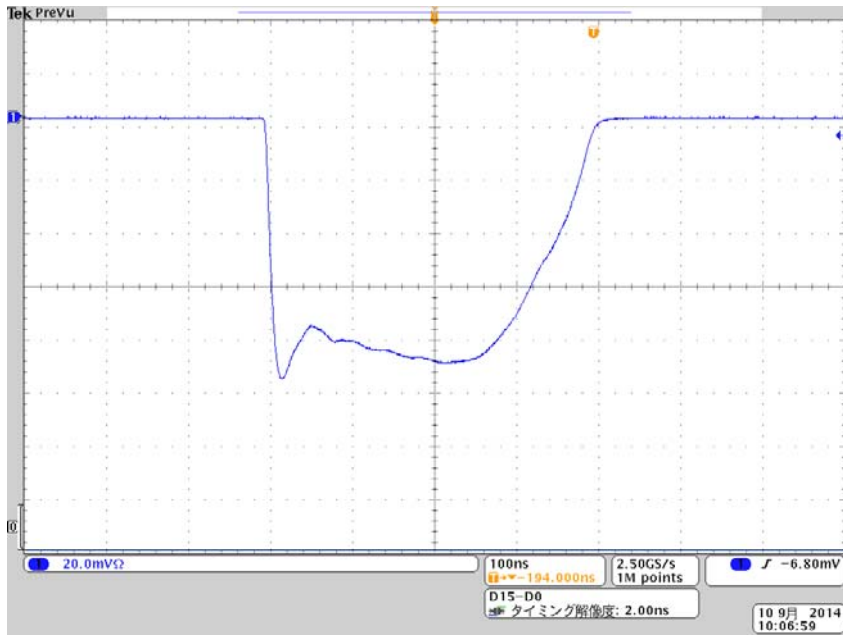

Fig. 7.3 M1 Pulse Envelope and Spectrum

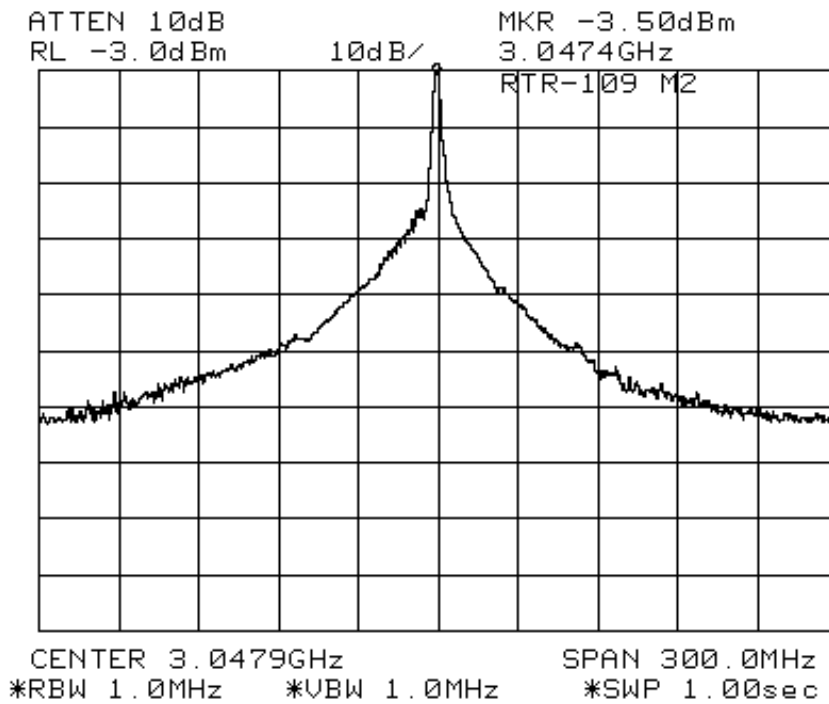
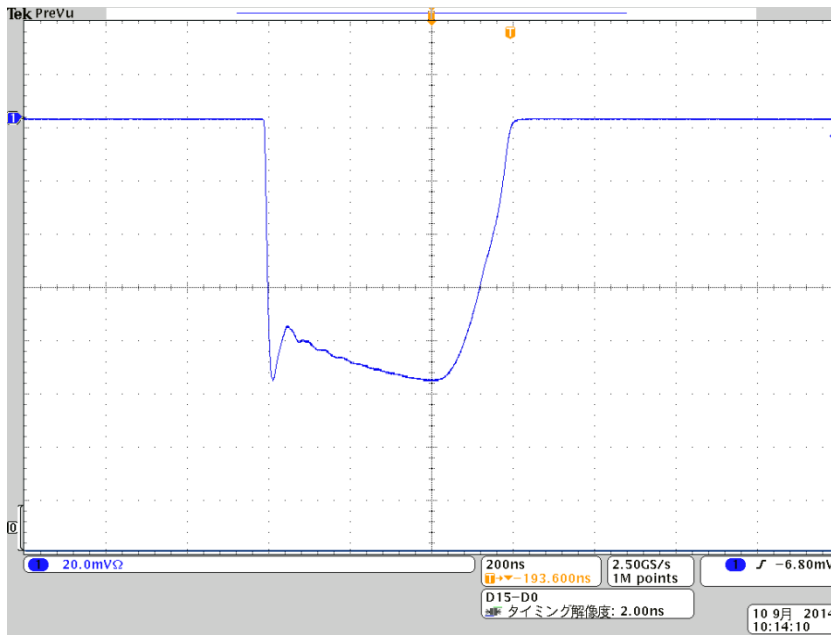

Fig. 7.4 M2 Pulse Envelope and Spectrum

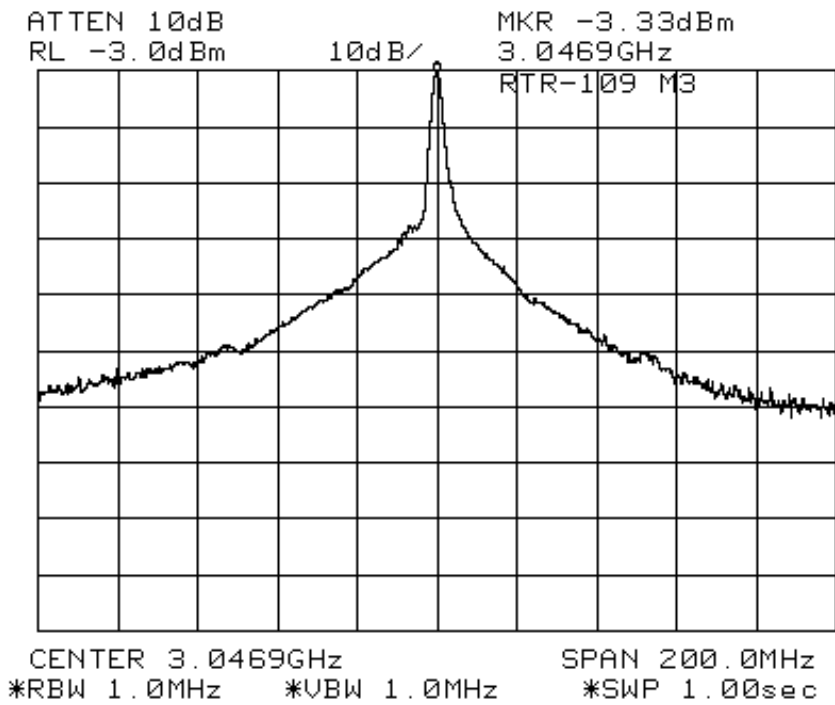
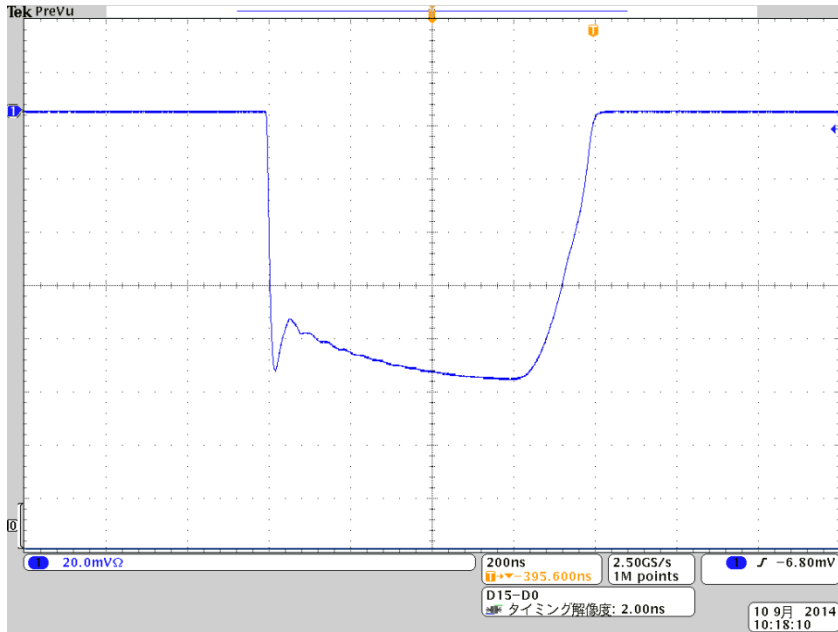

Fig. 7.5 M3 Pulse Envelope and Spectrum

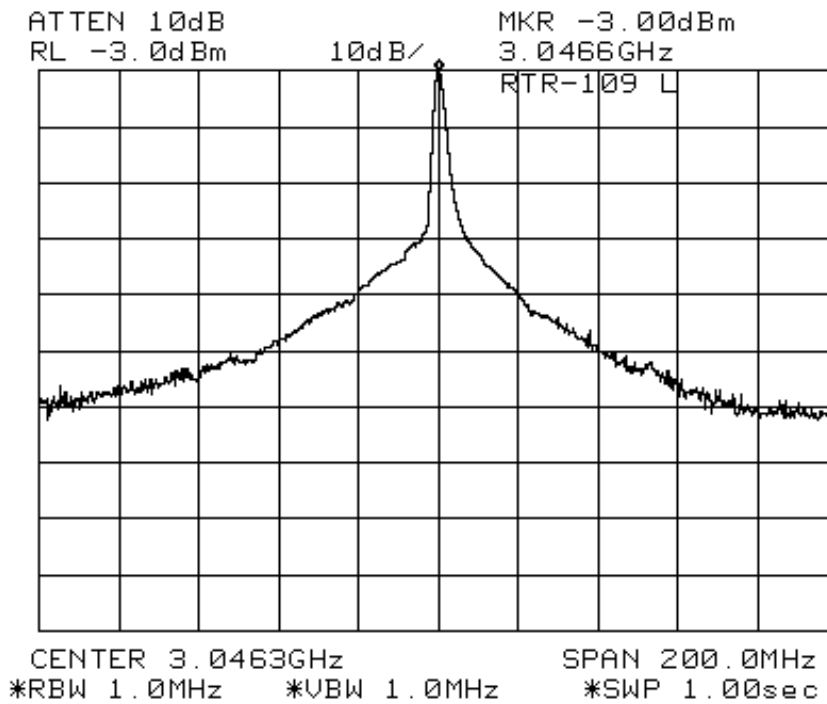
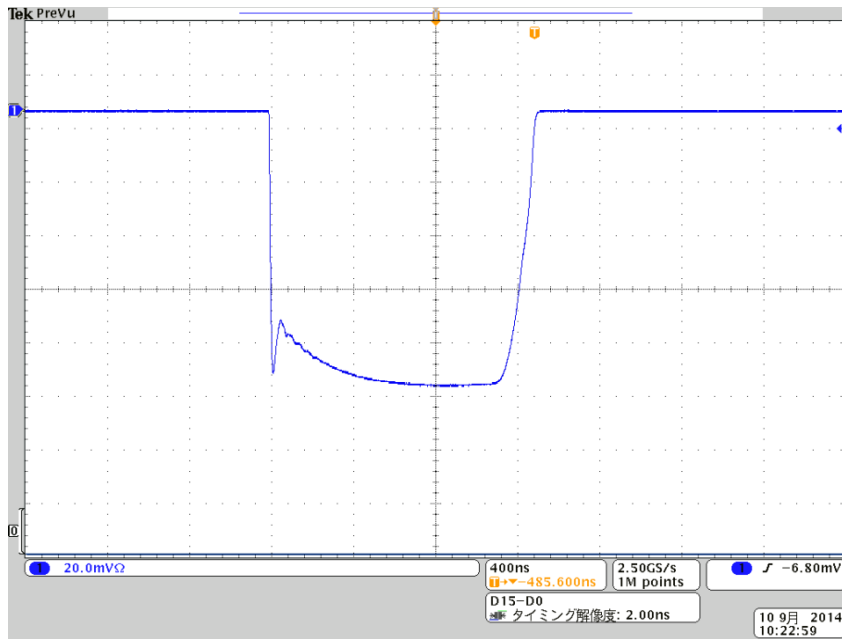

Fig. 7.6 L1 Pulse Envelope and Spectrum

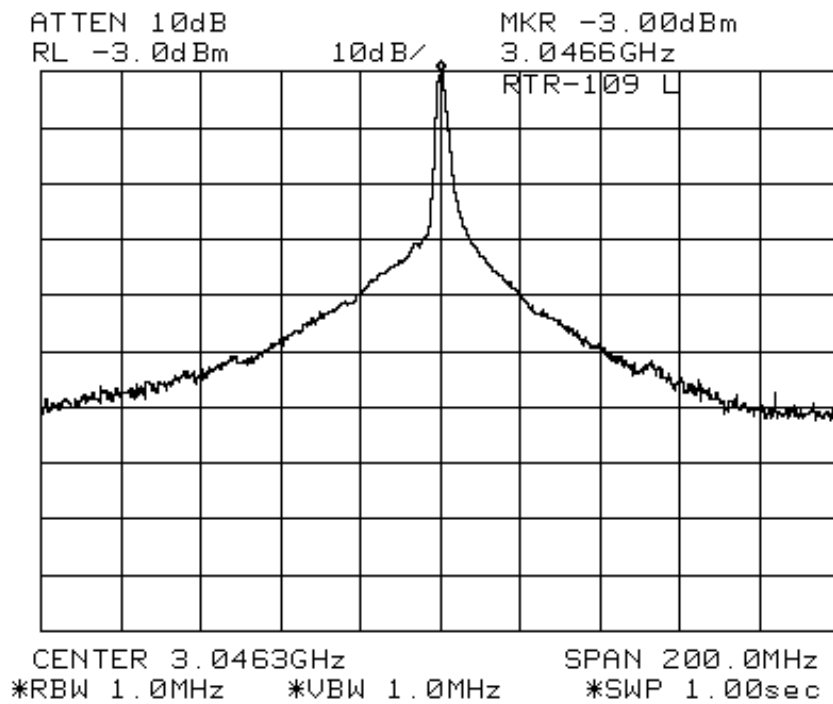
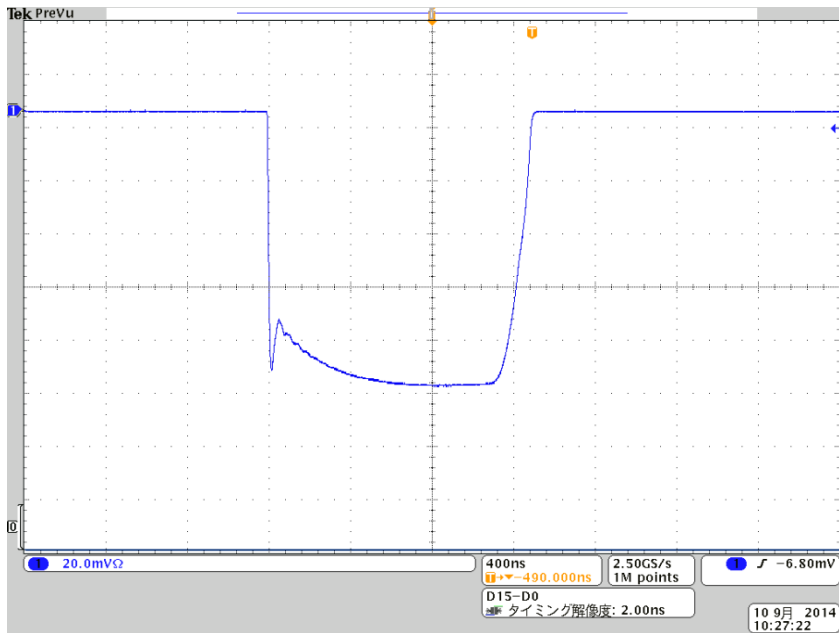

Fig. 7.7 L2 Pulse Envelope and Spectrum

8 Spurious Emission Plots measured at Antenna Terminal

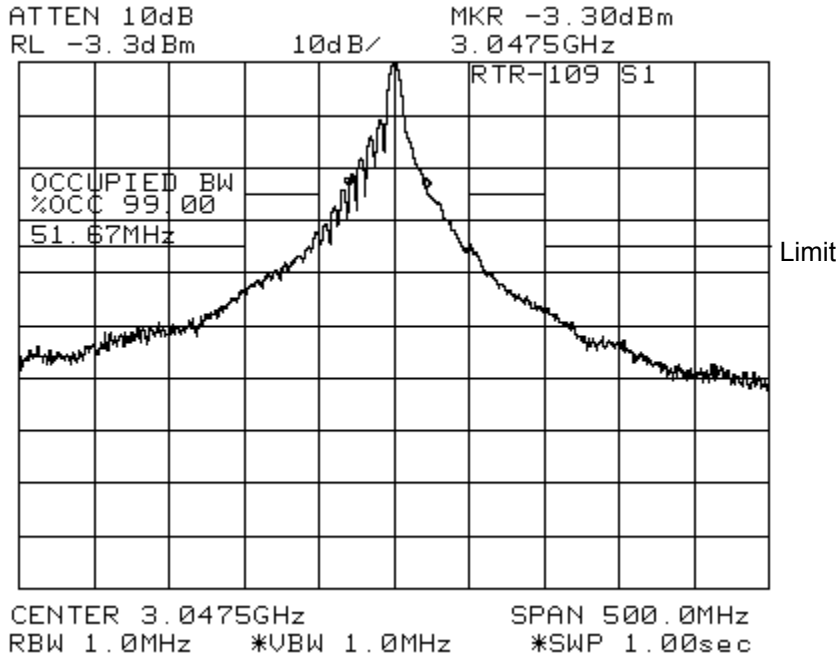

Fig. 8.1 for S1 Pulse

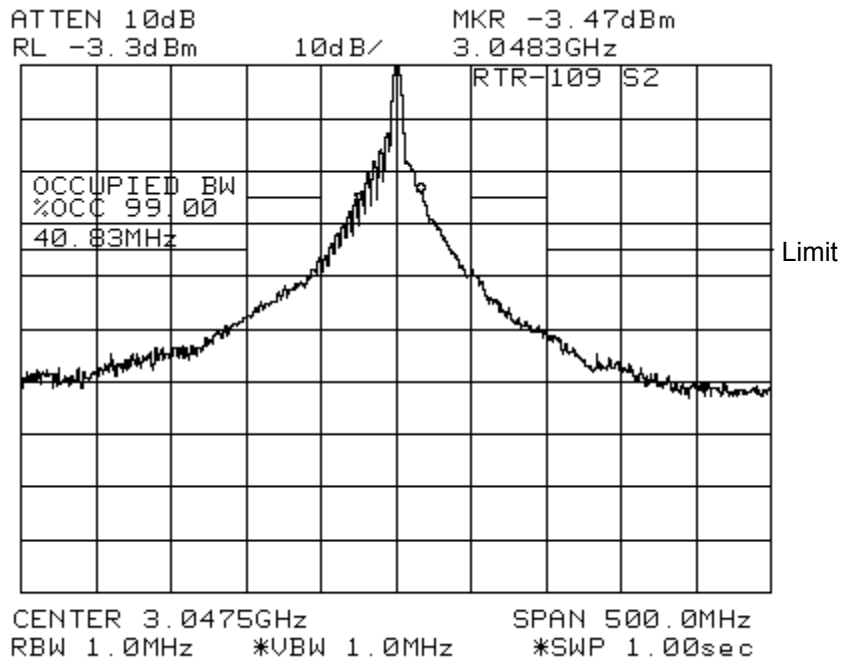

Fig. 8.2 for S2 Pulse

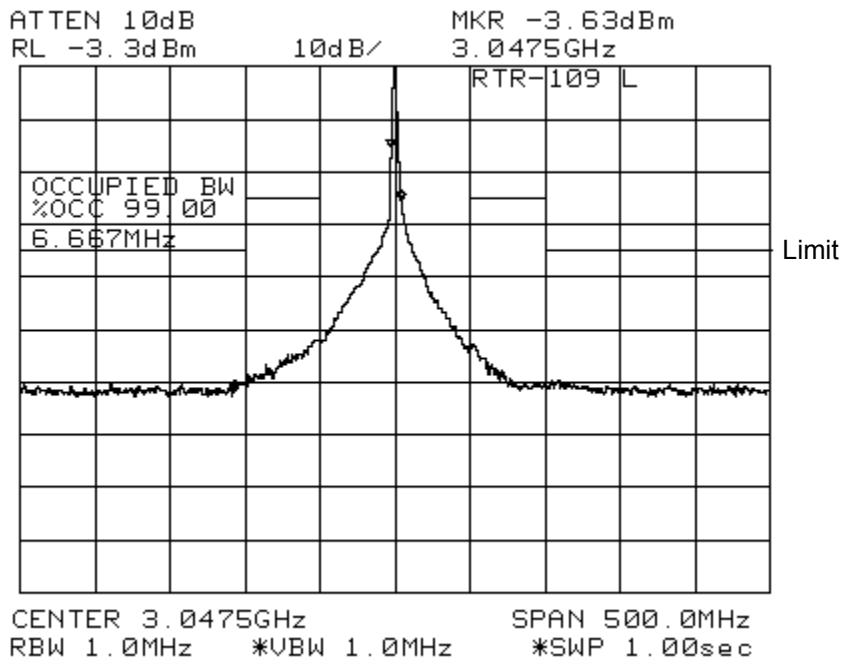

Fig. 8.7 for L2 Pulse

9 Field Strength Plots of Spurious Radiation

9.1 Maximum power radiation level

9.1.1 for S1 Pulse

(1) for Horizontal

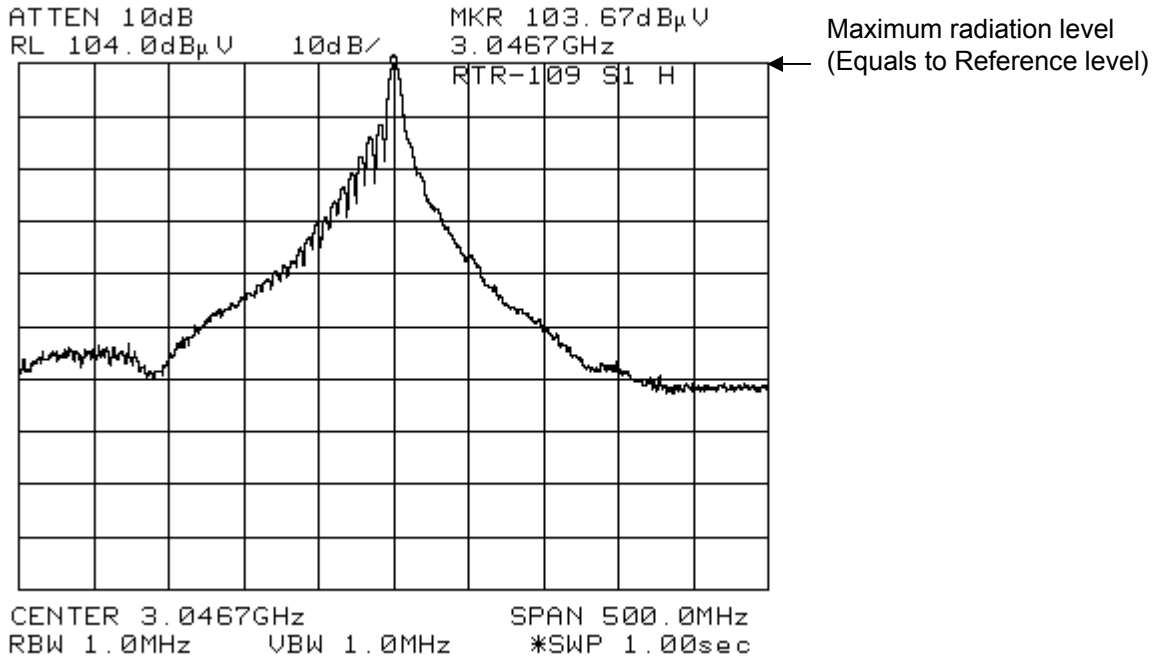

(2) for Vertical

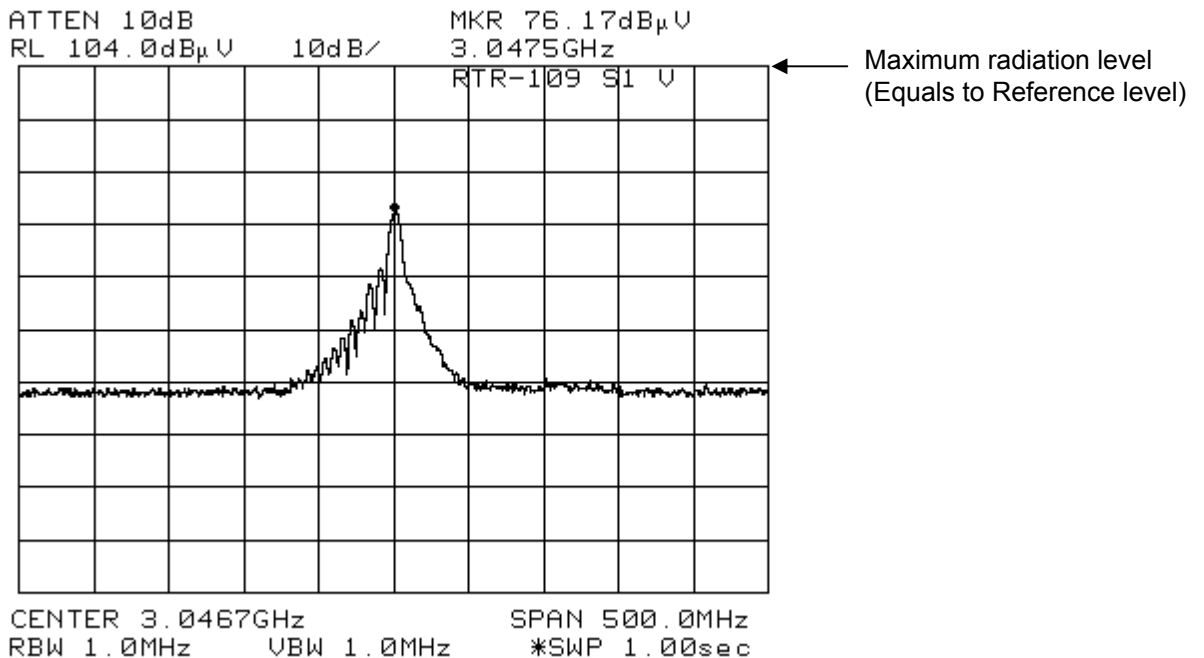

For the maximum power radiation level, the voltage value measured by the spectrum analyzer was converted into the electric field strength with the measuring antenna factor, Cable loss and Amp. gain.

Maximum power radiation level = 166.5 dBμV/m

Therefore, Emission Limit = 166.5 dBμV/m - 60 dB = 106.5 dBμV/m

9.2 Spurious emissions
9.2.1 for S1 pulse,

(1) for 9 kHz to 30 MHz

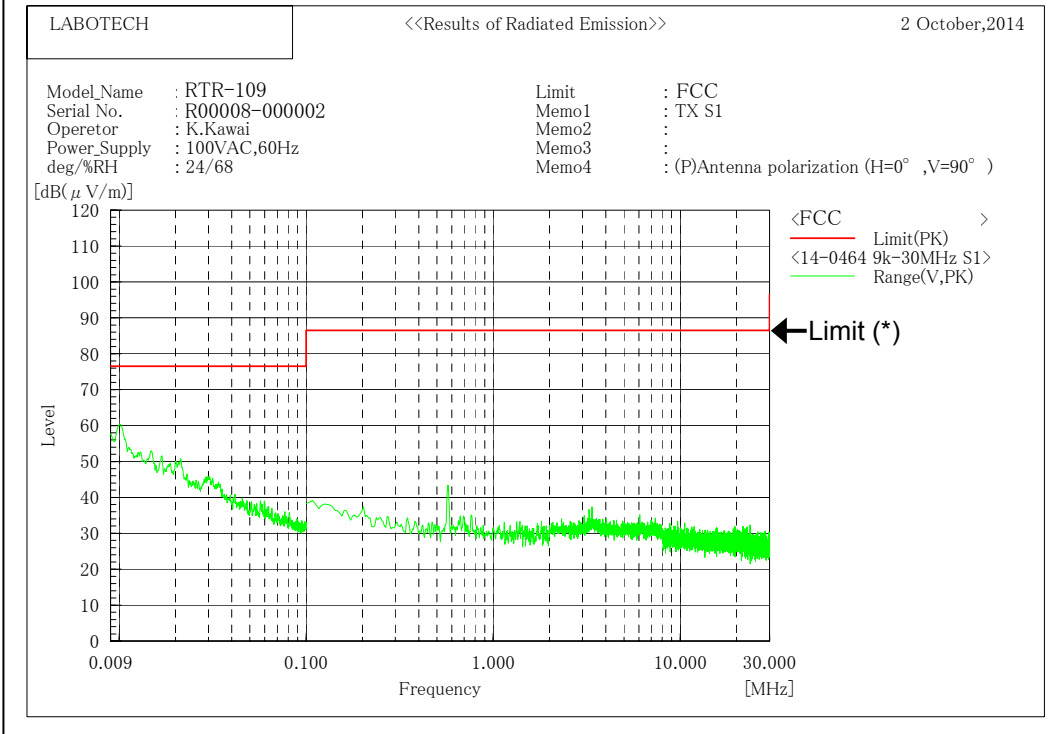
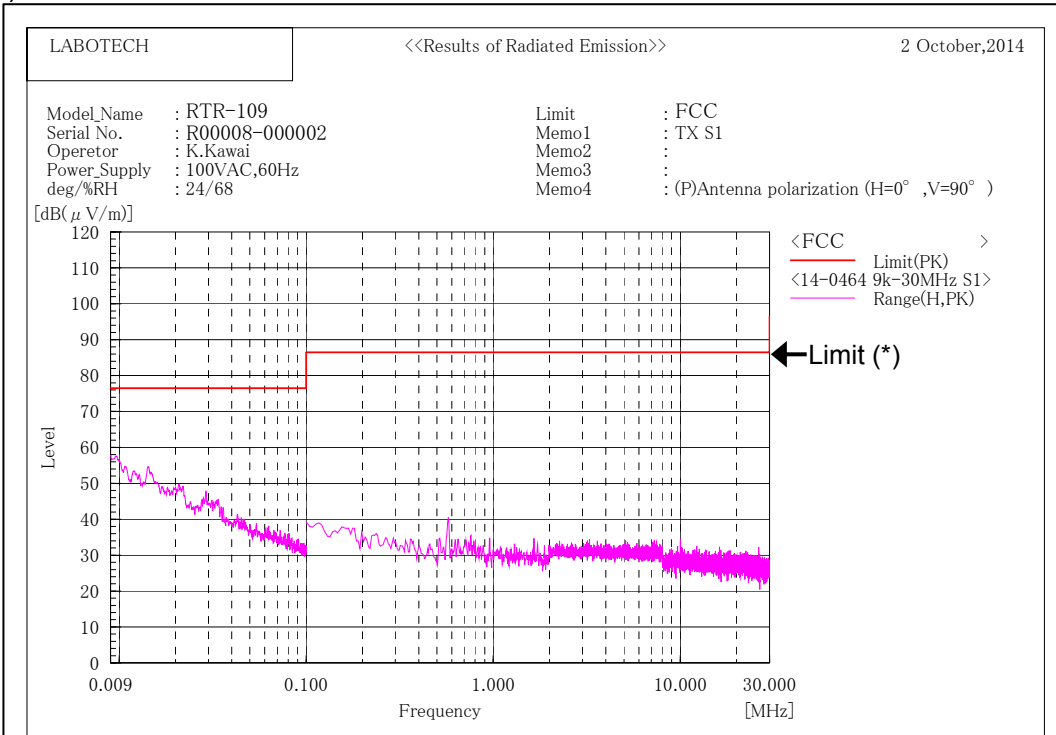

(*) The resolution bandwidth of the spectrum analyzer for the frequency range of 9 kHz to 100 kHz was set to 1 kHz, and to 10 kHz for 100 kHz to 30 MHz, instead of 1 MHz for the frequency range of 2 GHz to 40 GHz. The applicable limit was set at 30 dB lower than that computed in Clause 9.1 for the former frequency range, and 20 dB lower for the latter frequency range.

(2) for 30 MHz to 2000 MHz

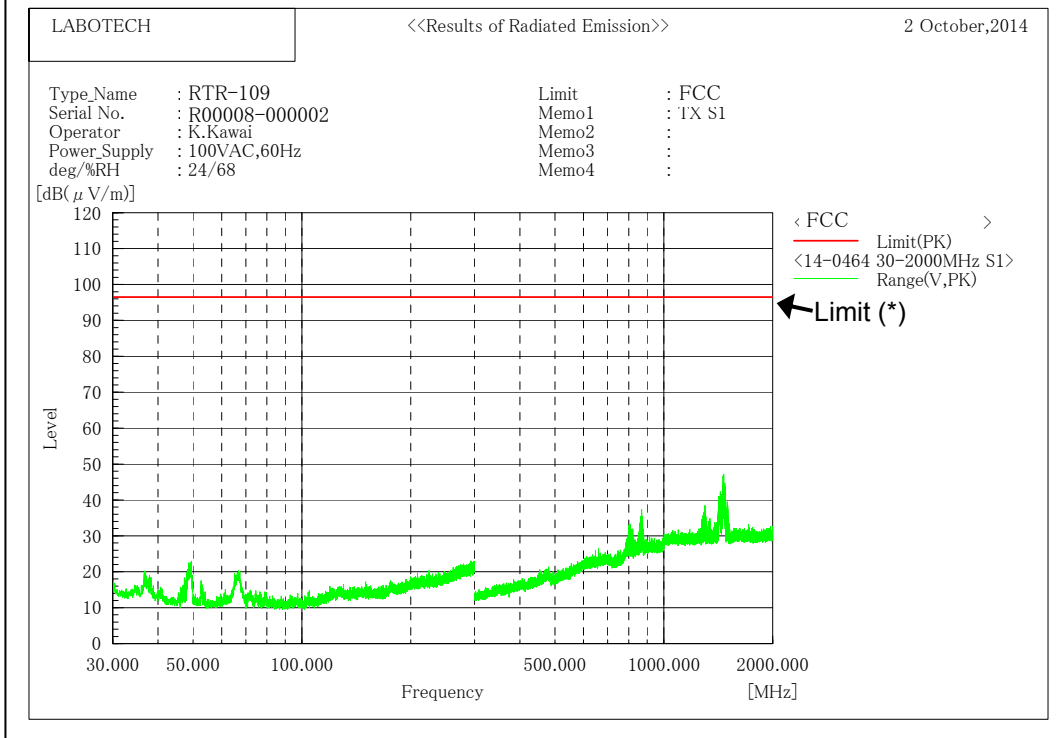
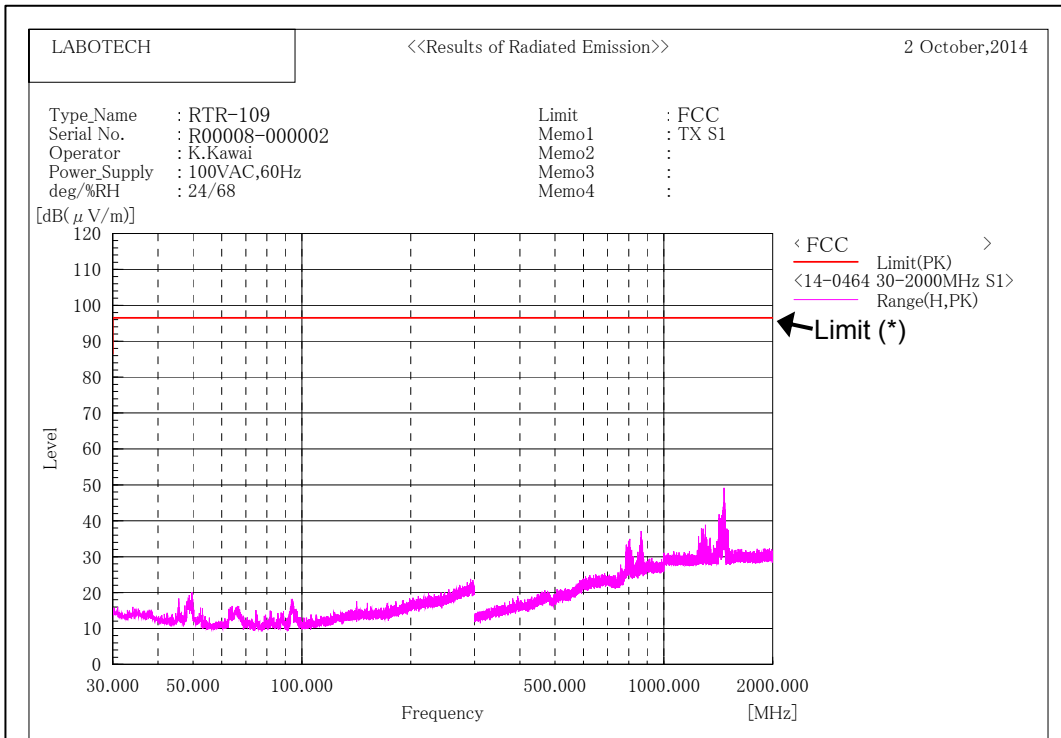

(*) The resolution bandwidth of the spectrum analyzer for the frequency range of 30 MHz to 2000 MHz was set to 100 kHz instead of 1 MHz for the frequency range of 2 GHz to 40 GHz. The applicable limit was set at 10 dB lower than that computed in Clause 9.1.

(3) for 2 GHz to 5.5 GHz
- for Horizontal

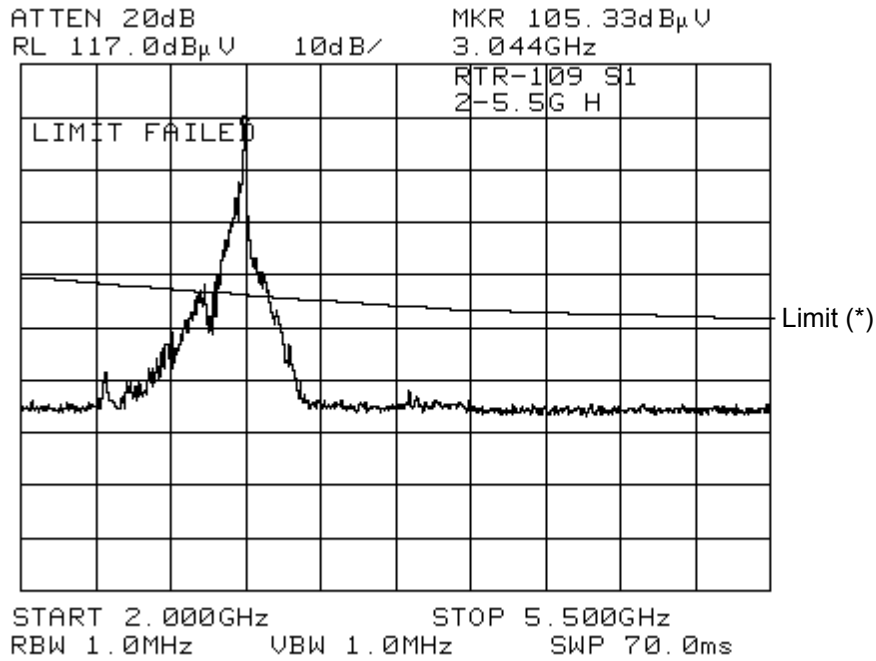

- for Vertical

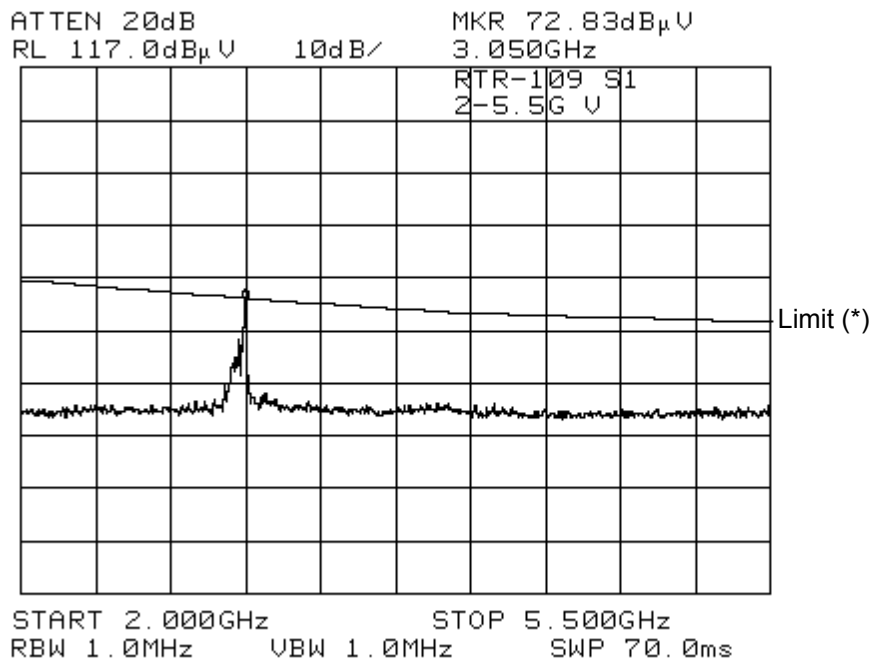

The notch filter (Pass band: 3050 \pm 150 MHz) was inserted between the measuring antenna and Spectrum Analyzer to prevent the excessive input to Spectrum Analyzer only for the test frequency range of 2 GHz to 5.5 GHz.

(*) The Limit is represented by the voltage value, which was derived from the electric field strength value with Antenna factor, Cable loss and Amp. gain included.

- for Vertical

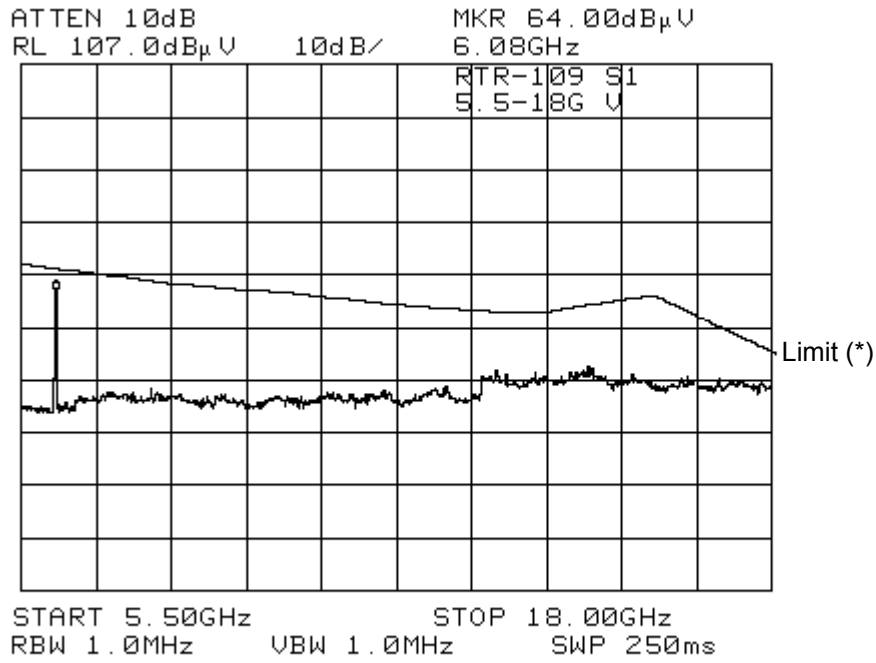

(*) The Limit is represented by the voltage value, which was derived from the electric field strength value with Antenna factor, Cable loss and Amp. gain included.

Minimum limit line for the frequency range of 5.5 GHz to 18 GHz is indicated in the above plots.

(5) for 18 GHz to 26.5 GHz
- for Horizontal

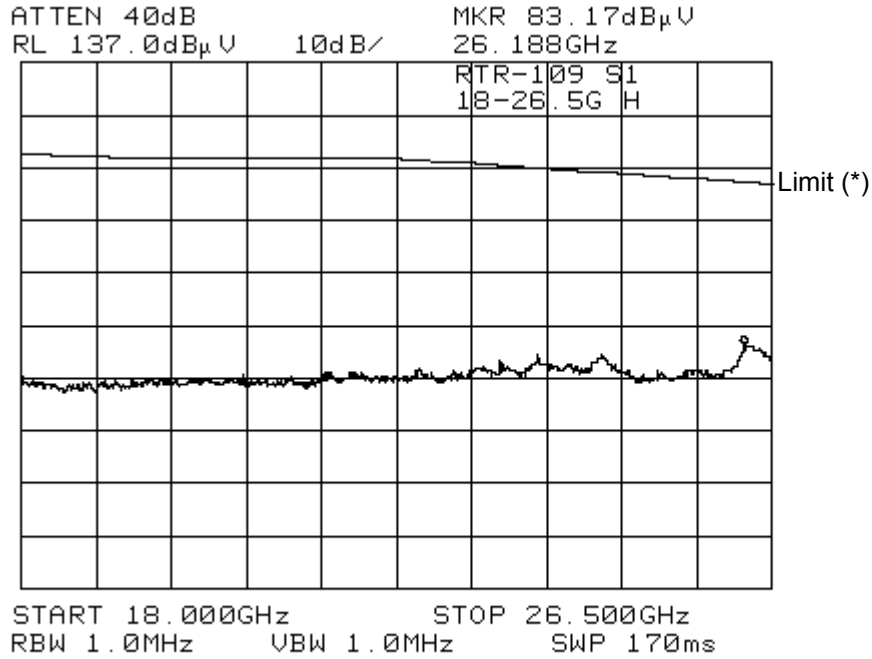

- for Vertical

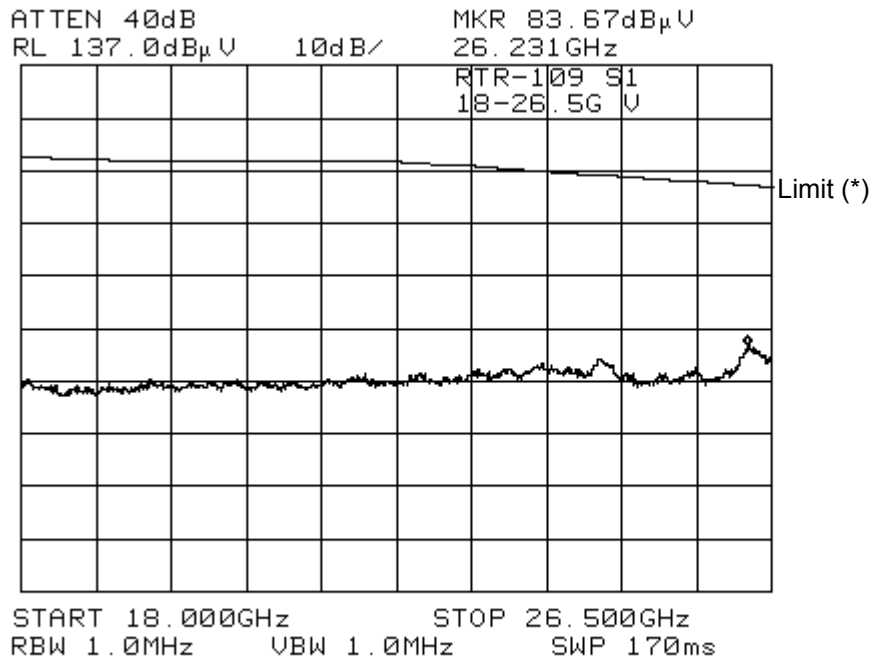

(*) The Limit is represented by the voltage value, which was derived from the electric field strength value with Antenna factor, Cable loss and Amp. gain.

Minimum limit line for the frequency range of 18 GHz to 26.5 GHz is indicated in the above plots.

(5) for 26.5 GHz to 40 GHz

- for Horizontal

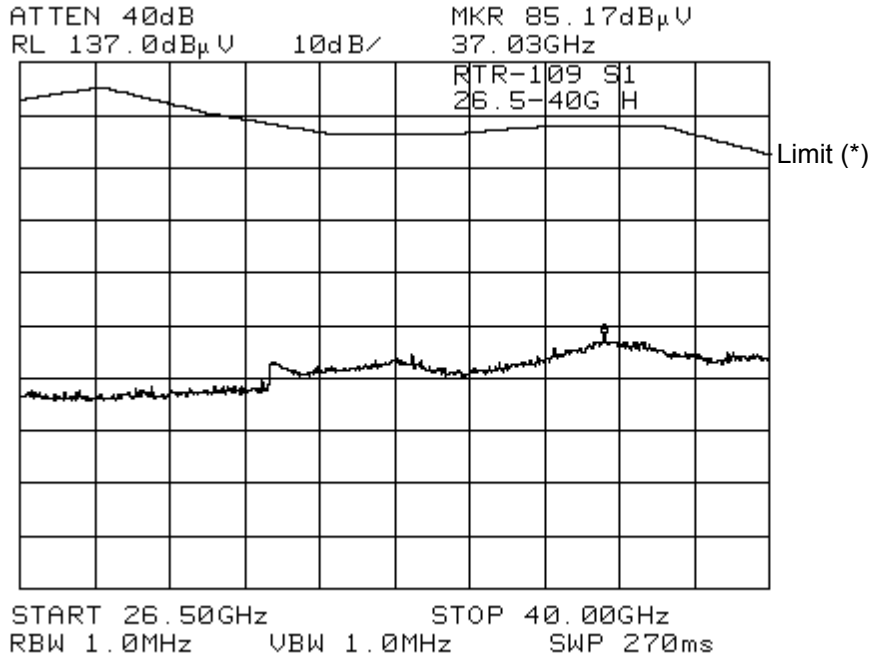

- for Vertical

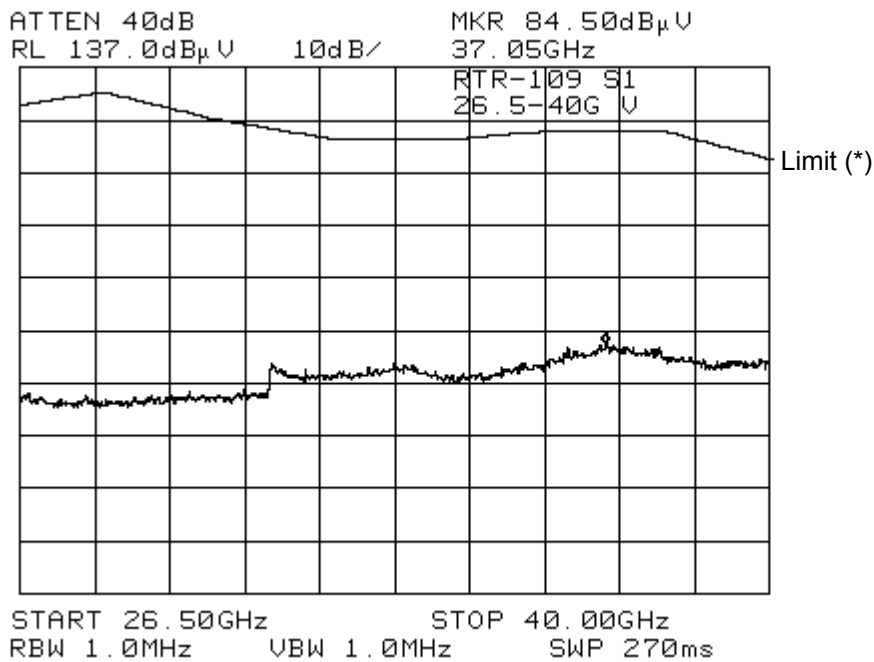

(*) Emission limit was converted from the electric field strength into the voltage values with Antenna factor, Cable loss and Amp. gain added to the calculation.

Minimum limit line for the frequency range of 26.5 GHz to 40 GHz is indicated in the above plots.

