

# Test Report

(FCC Rules 47 CFR,  
2.1046, 2.1047, 2.1049, 2.1051, 2.1053, 2.1055, 80.217 and 90.213)

**For**

**Trade name: Furuno**

**Model: Transceiver for Marine Radar**

**Type: RTR-100**

**Report No. LIC 12-15-046, Rev.1**

**Date of revised issue: 9 September 2022**

**Labotech International Co., Ltd.**

1-16, Fukazu-cho, Nishinomiya-shi, Hyogo, 663-8203 Japan

Tel: +81-798-63-1094 Fax: +81-798-63-1098

## Report Summary

LIC project number:	FLI 04-14-0701 (LIC 04-22-0461)				
Test report number of initial issue:	LIC 12-15-046		Date of initial issue	14 May 2015	
Test report number of revised/replaced issue:	LIC 12-15-046, Rev.1		Date of revised/replaced issue	9 September 2022	
Test report revision/ replacement history:	Rev. No	Date	Page	Item	Description of change/reason
	1	9 Sep. 2022	1, 2, 5, 9 and 12	Cover page, Report Summary Test standard(s)/Test specifications, TABLE OF CONTENTS, 2 Test Results Summary, 3.4 Frequency Stability,	Added FCC Part 90 (90.213)
			3 and 14	Report Summary Place of test, 3.5.2 (2) Test Site	Updated the registered laboratory information
			3	Report Summary Written by	Changed the preparer to: Written by: Arisa Ogino
			3	Report Summary Verified by Approved by	Changed the approver to: Name: Tadayuki Ekawa
			3	Report Summary	Added the disclaimer
			4	Testing Laboratory Status	Updated the laboratory status
Test standard(s)/ Test specifications:	<p>FCC Rules 47 CFR, Sections: 2.1046 - RF Power Output, 2.1047 - Modulation Characteristics, 2.1049 - Occupied Bandwidth, 2.1051 - Spurious Emissions at Antenna Terminals, 2.1053 - Field Strength of Spurious Radiation, 2.1055 - Frequency Stability, 80.217 - Suppression of Interference Aboard Ships. (Date of issue: 1 October 2014)</p> <p>90.213 - Frequency stability (the latest version on the day when the revised version was issued.)</p>				
Customer:	Furuno Electric Co., Ltd. 9-52 Ashihara-Cho, Nishinomiya-City, 662-8580 Japan				
Manufacturer:	Furuno Electric Co., Ltd. 9-52 Ashihara-Cho, Nishinomiya-City, 662-8580 Japan				
Trade name:	FURUNO				
Model:	Transceiver for Marine Radar				
Type:	RTR-100				
Product function and intended use:	For marine safety navigation				
Number of samples tested:	One				
Serial number:	R179-0298				
Power rating:	24 VDC, 100-115/220-230 VAC (for Processor unit)				
Product status:	Pre-production model				
Modifications made to samples during testing:	None.				
Date of receipt of samples:	1 April 2015				
Test period:	From 1 April 2015 to 20 April 2015				

Place of test:	<p>Labotech International Co., Ltd.</p> <p>- Nishinomiya Lab. 9-52, Ashihara-cho, Nishinomiya-shi, Hyogo, 662-8580 Japan Test firm designation number: JP2010 Test firm registration number: 696248</p> <p>- Nishinomiya-Hama Lab. 2-20, Nishinomiya-Hama, Nishinomiya-shi, Hyogo, 662-0934 Japan Test firm designation number: JP2011 Test firm registration number: 738202</p>
Test results/ Compliance:	<p>Passed.</p> <p>The test results of this report relate only to the samples tested.</p>
Tested by:	Koji Kawai
Written by:	Arisa Ogino
Verified by:	Tadayuki Ekawa
Approved by:	<p>Date: 9 September 2022</p> <p>Name: Tadayuki Ekawa</p> <p>Title: Manager, Testing &amp; Facilities Control Section, Technical Department, Labotech International Co., Ltd.</p> <p>Signature:</p> 

**Disclaimer:**

**The test results of this report relate only to the samples tested.**

**LIC has no responsibility for the followings except for the requirements of test standards.**

- The thing(s) in association with the test and information pertaining to it/them, which are provided by the customer; information described in Clause 1 of this report and information of the cable(s) used.
- The matter(s) specified by the customer; Test standard(s) applied, test item(s), test conditions, criteria, object(s) to be tested or excluded, operation mode(s) and connection/configuration.

## Testing Laboratory Status

Labotech International Co., Ltd. (hereafter called "LIC") has been holding the following status after having been assessed according to the provisions of ISO/IEC 17025 and/or the relevant rules:

(1) JAB Accredited Testing Laboratory:

- accredited by Japan Accreditation Board (JAB)
- Laboratory accreditation number: RTL03220 (Date of initial accreditation: 14 January 2011 (\*))
- Scope of accreditation: Electrical testing - EMC, Climatic, Vibration and Radio tests

(2) Telefication Listed Testing Laboratory:

- listed by Telefication B. V., (The Netherlands)
- Laboratory assignment number: L116 (Date of initial listing: 26 July 1999 (\*))
- for testing the following product categories/ test standards: EN 60945, IEC 61162-1/-2, IEC/EN 61162-450, IEC 62288, ETSI EN 301 843-1 / -2, ETSI EN 301 489-1 / -3 / -17

(3) TÜV Appointed EMC Test Laboratory:

- appointed by TÜV Rheinland Japan Ltd.
- Laboratory assignment number: UA 50046428 (Date of initial appointment: 21 December 1998 (\*))
- for carrying out the tests of EMC emission and immunity

(4) RMRS Recognized Testing Laboratory:

- recognized by Russian Maritime Register of Shipping (Russia)
- Laboratory recognition number: 17.13259.170 (Date of initial recognition: 27 January 2009 (\*))
- for carrying out testing in the field of:  
Electrical measurements and tests, EMC tests, Mechanical measurements and tests, Equipment protection degree tests, and Climatic tests for Ship's radio and navigational equipment and IEC 60945: 2002

(5) RRR Recognized Test Laboratory:

- recognized by Russian River Register (Russia)
- Certificate number: 131927 (Date of initial recognition: 31 May 2013 (\*))
- for carrying out of tests of ships radio and navigation equipment

(6) DNV Recognized Environmental Test Laboratory:

- recognized by Det Norske Veritas AS
- Recognition certificate number: 262.1-015854-J-12 (Date of initial recognition: 12 July 2013 (\*))
- Scope of recognition: Testing according to the standards IEC 60945, IEC 61162-1/-2/-450, IEC 62288, IEC 62388 and IEC 62252 Annex E
- Application: Provisions of Environmental, interface and safety testing

(7) CCS Recognized Test Agency:

- recognized by China Classification Society
- Recognition certificate number : DB13A00001 (Date of initial recognition : 29 January 2014 (\*))
- Scope of recognition : Performance/Environmental/EMC/Special purpose/Safety precautions tests for Electrical & Electronic Product including Maritime Navigation and Radio-communication Equipment & Systems

(8) SABS EMC A-Lab program Laboratory:

- recognized by South African Bureau of Standards
- Assigned Lab number : SABS/A-LAB/0042/2018 (Date of initial recognition : 5 July 2018 (\*))
- Approved List of EMC Standards : SANS 211 / 214-1 / 214-2 / 222 / 2332 / 2335, CISPR 11 / 14-1 / 14-2 / 22 / 32 / 35, SANS/IEC 60601-1-2, SANS/IEC 61326-1, IEC 61326-2-6, SANS/IEC 61000-3-2 / -3-3 / -4-2 / -4-3 / -4-4 / -4-5 / -4-6 / -4-8 / -4-11 / -6-1 / -6-2 / -6-3 / -6-4

(9) A2LA accredited Testing Laboratory:

- accredited by American Association of Laboratory Accreditation (A2LA)
- Certificate number: 5241.01 (Date of initial accreditation: 17 Jul 2019 (\*))
- Scope of accreditation: Electrical testing - Emissions - Radiated and Conducted, Radio - Maritime Radio Systems, Stations in the maritime services, Private land mobile radio service, Radio / Intentional radiators, RF Exposure and EMC - Automotive Electronic Devices (AED), Machine and Vehicle

(\*) The latest certification status may be found on the LIC website (<https://www.labotech-intl.co.jp/>).

## TABLE OF CONTENTS

Testing Laboratory Status .....	4
1 Principal Information .....	6
1.1 Equipment under test (EUT).....	6
1.2 Observation and comments .....	8
2 Test Results Summary .....	9
3 Test Results.....	10
3.1 RF Power Output (FCC Rule 47 CFR, 2.1046).....	10
3.2 Modulation Characteristics (FCC Rule 47 CFR, 2.1047) .....	10
3.3 Occupied Bandwidth (FCC Rule 47 CFR, 2.1049) .....	11
3.4 Frequency Stability (FCC Rule 47 CFR, 2.1055 and 90.213) .....	12
3.5 Spurious Emissions.....	13
3.5.1 Spurious Emissions at Antenna Terminals (FCC Rule 47 CFR, 2.1051) .....	13
3.5.2 Field Strength of Spurious Radiation (FCC Rule 47 CFR, 2.1053).....	14
3.6 Suppression of Interference Aboard Ships (FCC Rule 47 CFR, 80.217) .....	15
4 Test Setup for Measurements .....	16
5 Measuring Equipment List.....	18
6 Photograph of Test Setup/Arrangement.....	20
7 RF Envelope and Spectrum of the output pulse .....	22
8 Spurious Emission Plots measured at Antenna Terminal .....	29
9 Field Strength Plots of Spurious Radiation .....	33
10 Field Strength Plots for Suppression of Interference Aboard Ships .....	39

# 1 Principal Information

## 1.1 Equipment under test (EUT)

### 1.1.1 General

- (a) Trade name: Furuno
- (b) Manufacturer: Furuno Electric Co., Ltd.  
Ashihara-cho 9-52, Nishinomiya-city, 662-8580 Japan
- (c) Model:

	Type	Serial Number	Note
Transceiver	RTR-100	R179-0298	Contained in the Scanner.
Scanner	RSB-120		Antenna rotation rate: 26 rpm
Antenna	XN12AF XN20AF	---	One (1) selectable. Installed on Scanner.

- (d) Certification number: FCC ID: ADB9ZWRTR100
- (e) Primary Function: Search, Navigation and Anti-collision
- (f) Frequency Range: Fixed frequency, X-band (9410 MHz)  
Type of Emission: P0N  
(Emission designator)
- (g) Size and mass: Antenna Unit: 2040 mm (dia) X 570 mm (H), 39 kg (\*)  
(\*): with Antenna XN20AF installed.
- (h) Power Supply: 24 VDC (\*), 100-115/220-230 VAC (\*)  
(\*): fed through the Processor unit, not directly from AC/DC mains.

### 1.1.2 Transceiver

**Type:** RTR-100 (Contained in the Radar Scanner)

#### 1.1.2.1 Transmitter

- (a) Assignable Frequency for Shipborne Radar:  
Between 9300 and 9500 MHz (FCC Rule, 80.375 (d)-(1))
- (b) Type of RF Generator:  
Magnetron Type: MAF1615B  
Peak Output Power: 12 kW nominal
- (c) Magnetron Ratings:  
Center frequency of Magnetron: 9410 MHz nominal  
Tolerances:  
Manufacturing:  $\pm 30$  MHz

Pulling: 23 MHz  
Tolerance for 20°C temperature variation: -5 MHz

(d) Pulse Characteristics:

Pulse type	S1	S2	M1	M2	M3	L1	L2
Pulselength (µs)	0.08	0.12	0.22	0.38	0.68	1.2	1.2
PRR (Hz)	3000	2760	1500	1000	1000	600	500

**1.1.2.2 Modulator**

- (a) FET Type: 2SK1450  
Trigger Voltage: Approx. +20 VDC positive

**1.1.2.3 Receiver**

(a) Passband

RF Stage: 100 MHz

IF Stage:

Pulse type	S1	S2	M1	M2	M3	L1	L2
Passband (MHz)	17.5	10	10	4	4	1.7	1.7

- (b) Intermediate Frequency: 60 MHz
- (c) Gain (overall): approximately 100 dB
- (d) Overall Noise Figure: 4 dB (typical)
- (e) Video Output Voltage: 4 V Negative
- (f) Features Provided: Main bang suppression
- (g) If receiver is tunable, describe method for adjusting frequency:  
by adjustment of tuning voltage of receiver local oscillator (Automatic and manual)
- (h) Frequency adjustable range: 9410 MHz (center) ± 30 MHz

**1.1.3 Antenna and Scanner**

- (a) Antenna Rotation ON-OFF Switch: Provided.
- (b) Construction: Slotted array antenna
- (c) Length:

Antenna type	XN12AF	XN20AF
Length (cm)	126	204

- (d) Type of Beam: Vertical fan
- (e) Beam Width (3 dB):

Antenna type	XN12AF	XN20AF
Horizontal (°)	1.9	1.23
Vertical (°)	20	20

(f) Polarization: Horizontal

(g) Antenna Gain:

Antenna type	XN12AF	XN20AF
Gain (dBi)	27.5	30.0

(h) Attenuation of Major Side Lobes with respect to main beam:

Antenna type	XN12AF	XN20AF
Within $\pm 10^\circ$ (dB)	-24	-28
Outside $\pm 10^\circ$ (dB)	-30	-32

(i) Scanning (rotating or oscillating): Rotating

(j) Antenna Rotation Rate: 26 rpm

(k) Sector Scan: Not provided.

(l) Rated Loss of Transmission line per hundred feet:

Negligible. (Transmission path is only in the scanner unit.)

**1.1.4 Operational Features**

(a) Is positive means provided to indicate whether or not the overall operation of the equipment is such that it may be relied upon to provide effective operation in accordance with its primary function:

Yes (Receiver tuning indicator)

(b) Is the equipment for continuous operation: Yes

(c) Is provision made for operation with shore based radar beacons (RACONS):

Yes (RACONS)

**1.1.5 Construction Features**

(a) Does equipment embody replacement units with chassis type assembly: Yes

(b) Are fuse alarms provided: Fuses are provided.

(c) State units that are weatherproof: Antenna Unit (IEC 60529 – IP56)

(d) If all units are not housed in a single container, indicate number and give description of individual units: See Clause 1.1.1 (c) of this report.

(e) Approximate space required for installation excluding scanner: not applicable.

**1.2 Observation and comments**

None.



## 2 Test Results Summary

Clause No. of this report	47 CFR Section	Item	Result	Test Engineer
3.1	2.1046	RF Power Output	Passed.	K. Kawai
3.2	2.1047	Modulation Characteristics	Passed.	K. Kawai
3.3	2.1049	Occupied Bandwidth	Passed.	K. Kawai
3.4	2.1055 90.213	Frequency Stability	Passed.	K. Kawai
3.5		Spurious Emissions	---	---
3.5.1	2.1051	- Spurious Emissions at Antenna Terminal	Passed.	K. Kawai
3.5.2	2.1053	- Field Strength of Spurious Radiation	Passed.	K. Kawai
3.6	80.217	Suppression of Interference Aboard Ships	Passed.	K. Kawai

### 3 Test Results

#### 3.1 RF Power Output (FCC Rule 47 CFR, 2.1046)

**(1) Test conditions:**

For all TX (S1/S2/M1/M2/M3/L1/L2) Pulses, the transmitter output power was measured at the antenna port with Antenna replaced with the Non-reflective load.

**(2) Test setup:**

See Clause 4.

**(3) Test Results:**

Pulse type	S1	S2	M1	M2	M3	L1	L2
Magnetron Output, mean $P_m$ (W)	3.7	4.9	4.2	5.0	9.1	9.3	7.7
Magnetron Output, peak $P_p$ (kW) (*1)	13.9	13.9	13.0	13.1	13.2	13.2	13.2
Pulselength $T$ ( $\mu$ s) (-3 dB points) (*2)	0.088	0.128	0.214	0.379	0.690	1.176	1.176
PRR (Hz)	2998	2758	1499	1000	1000	600	500

(\*1)  $P_p$  (kW) =  $(P_m$  (W) / ( $T$  ( $\mu$ s)  $\times$  PRR (Hz)))  $\times$  1000

(\*2): Measured at -3 dB points of the RF envelope of the magnetron output pulse instead of at 50% points of the current of the magnetron, which are equivalent.

Environmental conditions observed: On 1 April 2015, 24°C to 24°C, 60% to 60%RH

Power supply voltage measured (\*): 24.0 VDC to 24.0 VDC.

(\*): Power input voltages to the external equipment (Processor unit) measured.

#### 3.2 Modulation Characteristics (FCC Rule 47 CFR, 2.1047)

**(1) Test Conditions:**

The RF envelope of the magnetron output pulse was measured using an envelope detector and an oscilloscope.

Each pulse spectrum was measured using a spectrum analyzer.

**(2) Test setup:**

See Clause 4.

**(3) Limits (FCC Rule, 80.213 (g)/80.209(b)):**

Upper limit frequency,  $f(U) = f_0 + f(AUBW)/2 - 1.5/T$

Lower limit frequency,  $f(L) = f_0 - f(AUBW)/2 + 1.5/T$

Note: Assigned frequency ( $f_0$ ): 9410 MHz (for X-band radars)

Authorized bandwidth ( $f(AUBW)$ ): 110 MHz (for X-band radars)

**(4) Test Results:**

Complied.

Pulse type	S1	S2	M1	M2	M3	L1	L2	Result
Pulselength T (μs) (-3 dB points) (*1)	0.088	0.128	0.214	0.379	0.690	1.176	1.176	Not applicable
Rise time tr (μs) (10 - 90 % amplitude)	0.020	0.026	0.029	0.052	0.056	0.056	0.056	Not applicable
Decay time td (μs) (90 - 10 % amplitude)	0.102	0.122	0.119	0.128	0.124	0.120	0.128	Not applicable
PRR (Hz)	2998	2758	1499	1000	1000	600	500	Not applicable
Guard Band f(1.5/T) (MHz) (*2)	17.0	11.8	7.0	4.0	2.2	1.3	1.3	Not applicable
f(U) (MHz)	9448.0	9453.2	9458.0	9461.0	9462.8	9463.7	9463.7	Not applicable
f(L) (MHz)	9372.0	9366.8	9362.0	9359.0	9357.2	9356.3	9356.3	Not applicable
Frequency at maximum emission (MHz)	9413.8	9414.1	9414.7	9414.8	9413.6	9413.6	9413.6	Complied

(\*1): Measured at -3 dB points of the RF envelope of the magnetron output pulse instead of at 50% points of the voltage/current of the magnetron, which are equivalent.

(\*2): Guard Band is specified to be equal to 1.5/T MHz, where "T" is the pulselength in microseconds. (FCC Rule 47 CFR, 80.209(b))

Measured Plots: See Clause 7.

Environmental conditions observed: On 1 April 2015, 24°C to 24°C, 60% to 60%RH

Power supply voltage measured (\*): 24.0 VDC to 24.0 VDC.

(\*): Power input voltages to the external equipment (Processor unit) measured.

**3.3 Occupied Bandwidth (FCC Rule 47 CFR, 2.1049)**

**(1) Test conditions:**

For all TX (S1/S2/M1/M2/M3/L1/L2) Pulses, the transmitter occupied bandwidth was measured at the antenna port with Antenna replaced with the Non-reflective load.

**(2) Test setup:**

See Clause 4.

**(3) Test Results:**

Pulse type	S1	S2	M1	M2	M3	L1	L2
Occupied bandwidth (MHz)	43.1	30.3	27.5	17.4	9.2	6.4	6.4

Spectrum plots: See Clause 8.

Environmental conditions observed: On 1 April 2015, 24°C to 24°C, 60% to 60%RH

Power supply voltage measured (\*): 24.0 VDC to 24.0 VDC.

(\*): Power input voltages to the external equipment (Processor unit) measured.

### 3.4 Frequency Stability (FCC Rule 47 CFR, 2.1055 and 90.213)

#### (1) Test Conditions:

- (1) Radar Transmitter settings: All TX (S1/S2/M1/M2/M3/L1/L2) Pulses
- (2) Ambient Temperature settings: - 30°C to + 50°C (10°C interval)
- (3) Power Supply Voltage settings: 85 /100/115 % of nominal voltage (20.4/24.0/27.6 VDC)

#### (2) Test setup:

See Clause 4.

#### (3) Frequency Tolerance Limits (FCC Rule 47 CFR, 80.209(b), 90.213(a)):

Pulse type	S1	S2	M1	M2	M3	L1	L2
f(U) (MHz)	9448.0	9453.2	9458.0	9461.0	9462.8	9463.7	9463.7
f(L) (MHz)	9372.0	9366.8	9362.0	9359.0	9357.2	9356.3	9356.3

See Clause 3.2 for details.

#### (4) Test Results:

Complied.

Power Supply Voltage setting (\*): 20.4 VDC

Pulse type		S1	S2	M1	M2	M3	L1	L2	Result
Frequency at maximum emission (MHz)	-30°C	9422.9	9423.4	9423.7	9423.6	9422.9	9422.5	9422.9	Complied.
	-20°C	9421.4	9421.1	9421.9	9421.3	9421.1	9420.6	9420.8	Complied.
	-10°C	9419.5	9419.9	9419.9	9419.7	9419.3	9419.1	9419.4	Complied.
	0°C	9417.6	9417.7	9418.3	9417.9	9417.1	9417.2	9417.6	Complied.
	+10°C	9416.1	9415.6	9416.6	9416.0	9415.7	9415.8	9415.7	Complied.
	+20°C	9413.8	9414.1	9414.7	9414.8	9413.6	9413.6	9413.6	Complied.
	+30°C	9411.7	9412.1	9412.7	9412.5	9411.9	9411.8	9412.0	Complied.
	+40°C	9410.3	9410.2	9410.9	9410.9	9410.3	9410.1	9410.5	Complied.
	+50°C	9408.9	9409.2	9410.1	9409.6	9408.8	9409.3	9409.3	Complied.

Power Supply Voltage setting (\*): 24.0 VDC

Pulse type		S1	S2	M1	M2	M3	L1	L2	Result
Frequency at maximum emission (MHz)	-30°C	9423.2	9423.3	9423.6	9423.5	9422.3	9422.6	9422.7	Complied.
	-20°C	9421.5	9421.3	9421.8	9421.7	9420.5	9420.6	9420.8	Complied.
	-10°C	9419.5	9419.3	9420.3	9419.8	9419.3	9419.4	9419.1	Complied.
	0°C	9417.5	9417.7	9417.9	9417.9	9417.1	9417.1	9417.4	Complied.
	+10°C	9416.5	9416.4	9416.5	9416.5	9415.6	9415.9	9415.8	Complied.
	+20°C	9413.6	9413.7	9414.5	9414.3	9413.7	9413.7	9413.7	Complied.
	+30°C	9412.5	9412.2	9412.8	9412.6	9412.0	9412.2	9412.2	Complied.
	+40°C	9410.7	9410.2	9410.9	9410.1	9410.3	9410.2	9410.6	Complied.
	+50°C	9408.5	9409.0	9409.4	9409.6	9409.3	9409.1	9409.4	Complied.

Power Supply Voltage setting (\*): 27.6 VDC

Pulse type		S1	S2	M1	M2	M3	L1	L2	Result
Frequency at maximum emission (MHz)	-30°C	9423.3	9423.4	9423.6	9423.5	9422.8	9422.7	9422.9	Complied.
	-20°C	9421.3	9421.1	9422.4	9421.6	9421.1	9420.7	9420.8	Complied.
	-10°C	9419.5	9419.5	9420.3	9419.9	9419.8	9419.0	9419.4	Complied.
	0°C	9417.8	9418.0	9418.3	9418.0	9417.3	9417.3	9417.6	Complied.
	+10°C	9415.9	9416.4	9416.3	9416.2	9415.5	9415.3	9415.4	Complied.
	+20°C	9413.8	9414.1	9414.5	9414.7	9413.8	9413.7	9413.7	Complied.
	+30°C	9411.8	9411.9	9412.6	9412.6	9412.0	9411.8	9412.2	Complied.
	+40°C	9410.6	9410.2	9411.5	9410.9	9410.5	9411.1	9410.8	Complied.
	+50°C	9408.8	9409.3	9409.6	9409.6	9409.5	9409.3	9409.5	Complied.

Environmental conditions observed: On 2 April 2015, 22°C to 24°C, 58% to 56%RH  
 On 3 April 2015, 24°C to 23°C, 60% to 63%RH  
 On 4 April 2015, 22°C to 24°C, 62% to 64%RH

Power supply voltage measured (\*): 24.0 VDC to 24.0 VDC.

(\*): Power input voltages to the external equipment (Processor unit) measured.

**3.5 Spurious Emissions**

**3.5.1 Spurious Emissions at Antenna Terminals (FCC Rule 47 CFR, 2.1051)**

**(1) Test Conditions:**

For all TX (S1/S2/M1/M2/M3/L1/L2) Pulses, the transmitter output power will be measured at the antenna port with Antenna replaced with the Non-reflective load.

**(2) Test setup:**

See Clause 4.

**(3) Emission Limits (FCC Rule 47 CFR, 80.211 (f)):**

Frequency removed from the assigned frequency	Emission attenuation (mean power, dB)
50 - 100 % (of the authorized bandwidth)	At least 25
100 - 250 % (of the authorized bandwidth)	At least 35
more than 250 % (*) (of the authorized bandwidth)	At least 43 + 10 log <sub>10</sub> (mean power in watts)

Note: (1) Authorized bandwidth = 110 MHz (for X-band radars)

(\*) - for the relevant frequency bands, tests were performed according to FCC Rule, 2.1053. See Clause 3.5.2.

**(4) Test Results:**

Complied.

Spectrum Plots: See Clause 8.

Environmental conditions observed: On 1 April 2015, 24°C to 24°C, 60% to 60%RH  
Power supply voltage measured (\*): 24.0 VDC to 24.0 VDC.  
(\*): Power input voltages to the external equipment (Processor unit) measured.

**3.5.2 Field Strength of Spurious Radiation (FCC Rule 47 CFR, 2.1053)**

**(1) Test Conditions:**

For all TX (S1/S2/M1/M2/M3/L1/L2) Pulses, the Radiated Emission test was performed.  
(a) For the test frequency range of 9 kHz to 2000 MHz, the Antenna for Transceiver was replaced with the rotating non-reflective load. Spurious emissions for 9 kHz to 2000 MHz are not found at the antenna terminal due to its structure (Waveguide tube). The EUT cabinet radiation was measured with the EUT rotated 360°.  
(b) For 2 GHz to 40 GHz, the Antenna was set to the Transceiver with the rotating mode.

**(2) Test Site:** LIC Nishinomiya-Hama Laboratory, Semi-Anechoic Chamber

**(3) Distance between the radar set and measuring antenna:** 3 m

**(4) Test setup:**

For the test frequency range of 2 GHz to 40 GHz, the GRP (Ground reference plane, metal floor) between the EUT and the measuring (receiving) antenna was lined with the Radio Absorbers (2.4 m × 3.6 m × 0.3 m) to reduce the influences of the reflections of the RF waves from the floor.

**Measuring (Receiving) Antenna height and polarization:**

(a1) 1.5 m for the test frequency range of 9 kHz to 30 MHz,  
(a2) 1 m to 4 m for the test frequency range of 30 MHz to 2000 MHz,  
(b) 2.0 m that was same as those for the EUT for the test frequency range of 2 GHz to 40 GHz,  
(c) Antenna polarization: vertical and horizontal.

**EUT height:**

(a) 0.8 m for the test frequency range of 9 kHz to 2000 MHz.  
(b) 2.0 m for the test frequency range of 2 GHz to 40 GHz.

See Clauses 4 and 6.

**(5) Field Strength Limits (FCC Rule 47 CFR, 80.211 (f)):**

Frequency removed from the assigned frequency	Emission attenuation (mean power, dB)
50 - 100 % (*) (of the authorized bandwidth)	At least 25
100 - 250 % (*) (of the authorized bandwidth)	At least 35
more than 250 % (of the authorized bandwidth)	At least 43 + 10 log <sub>10</sub> (mean power in watts)

Note: (1) Assigned frequency (center frequency) = 9410 MHz (for X-band radars)  
(2) Authorized bandwidth = 110 MHz (for X-band radars)  
(\*): for the relevant frequency bands, tests were performed according to FCC Rule 47 CFR, 2.1051. See Clause 3.5.1.

**(6) Test Results:**

Complied.

From the results of the pre-tests, the spurious emission level was found to be the maximum with S1 pulse. Consequently, the test was performed only with S1 pulse.

$$\begin{aligned}
 [\text{Limit}] &= 43 + 10 \log_{10} (\text{mean power in watts}) \\
 &= 43 + 10 \log_{10} (3.7) \\
 &= 48.6
 \end{aligned}$$

where, [ mean power in watts ] = 3.7 W for S1 pulse. See 3.1.

For this time, Limit of 60 dB was applied for the test.

From the results of the pre-tests, the spurious emission level was found to be the maximum with S1 pulse and XN20AF. Consequently, the final test was performed only with S1 pulse and XN20AF. The electric field strength of the maximum power radiation was 165.6µV/m with S1 pulse. Consequently, the allowable emission limit was set to 105.6µV/m (= 165.6µV/m - 60 dB).

Spectrum plots: See Clause 9.

Spurious emission levels measured were found to be attenuated more than 20 dB below the limits.

Environmental conditions observed: On 11 April 2015, 23°C to 24°C, 67% to 56%RH  
 On 20 April 2015, 21°C to 21°C, 53% to 53%RH  
 Power supply voltage measured (\*): 24.0 VDC to 24.0 VAC.  
 (\*): Power input voltages to the external equipment (Processor unit) measured.

**3.6 Suppression of Interference Aboard Ships (FCC Rule 47 CFR, 80.217)**

**(1) Test Conditions/Test Setup:**

The test was performed at the antenna port with the Standby (Receive) mode.

**(2) Test frequency range:** 9 kHz to 40 GHz

**(3) Spurious Emission Limits for Receivers:**

For delivered power to artificial antenna,

Frequency	Power to artificial antenna	Resolution bandwidth of Spectrum analyzer
	(µW)	
9 kHz - 150 kHz	400	1 kHz
150 kHz - 30 MHz		10 kHz
30 MHz - 100 MHz	4,000	100 kHz
100 MHz to 300 MHz	40,000	
300 MHz - 1 GHz	400,000	1 MHz
1 GHz - 40 GHz		

**(4) Test Results:**

Complied.

Tests were performed with the EUT Standby mode (= receive only mode).  
 Spurious emission levels measured were found to be attenuated more than 20 dB below the limits.

Spectrum plots: See Clause 10.

Environmental conditions observed: On 1 April 2015, 24°C to 24°C, 60% to 60%RH  
 Power supply voltage measured (\*): 24.0 VDC to 24.0 VDC.  
 (\*): Power input voltages to the external equipment (Power supply unit) measured.

## 4 Test Setup for Measurements

(1) Test Setup for Clauses 3.1, 3.2, 3.3, 3.4, and 3.5.1.

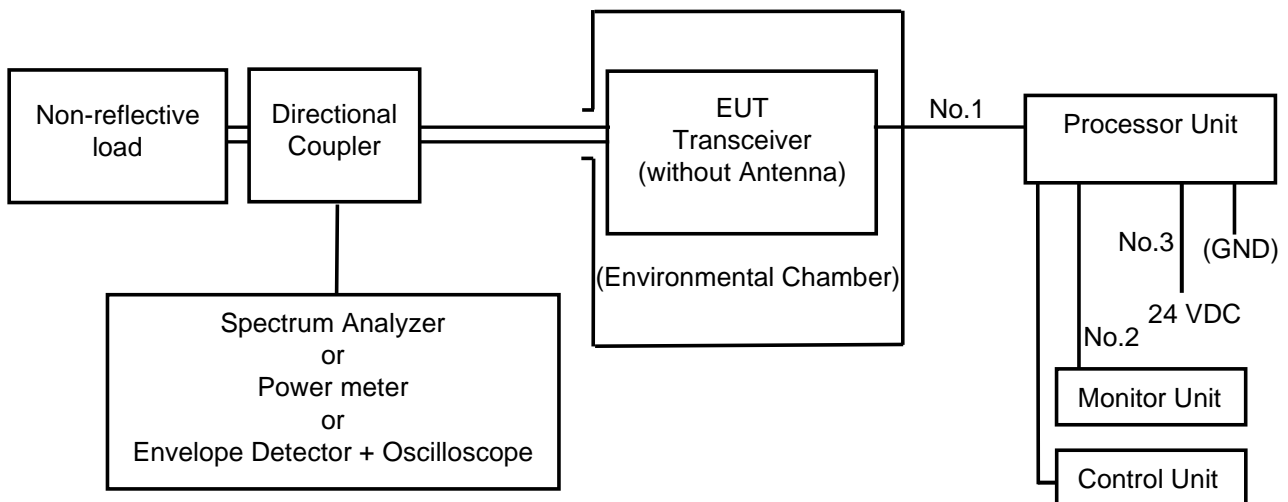

(2) Test Setup for Clause 3.5.2.

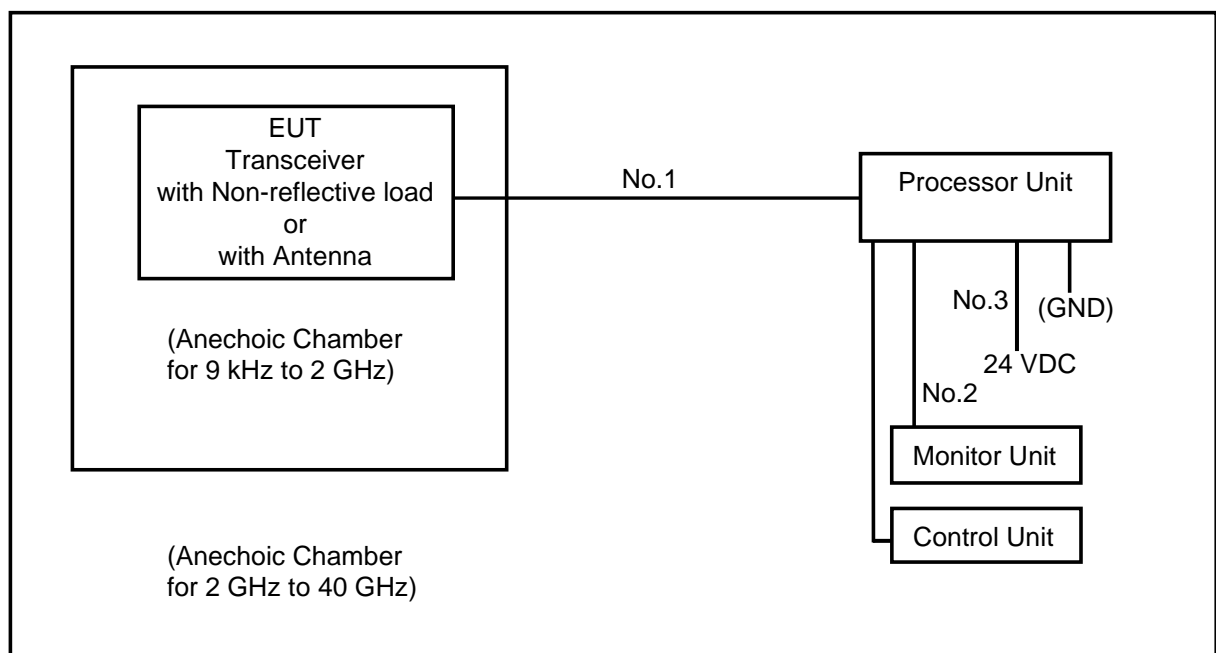



(3) Test Setup for Clause 3.6.

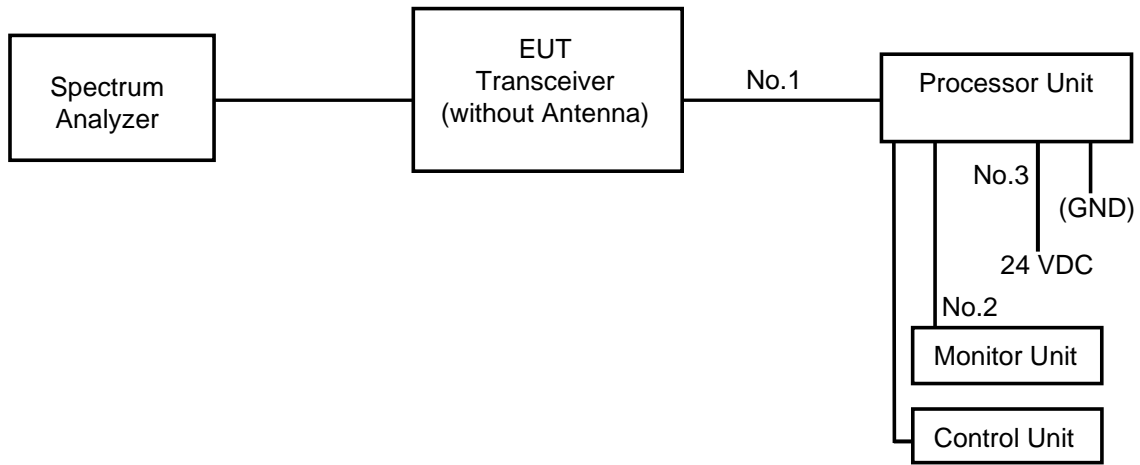

Cable designations:

No.	Type	Length (m)
1	RW-0030	20
2	DVI-D/D S-LINK	10
3	DPYC-6	5

## 5 Measuring Equipment List

(1) For 3.1 RF Power Output:

C/N	Instrument	Type	S/N	Manufacturer	Date of last calibration	Calibration interval
120121202	Directional Coupler (X-band)	5D364S	R05762	Shimada	10 April 2014	1 year
120121202	Dummy Load (X-band)	4D376	R4535004	Shimada	10 April 2014	1 year
----	Waveguide (for X-band)	WRJ-10 (l = 60 cm)	----	Furuno	----	----
HT552	Power meter	E4418B	GB43315050	Agilent	17 October 2014	1 year
HT653	Attenuator	8491B(10dB)	MY39264135	Agilent	6 March 2015	1 year
HT926	Power Sensor	E9304A-H18	MY53100039	Agilent	22 July 2014	1 year
HT432	DC Power Supply	PAN55-20	AK003307	KIKUSUI	----	----

(2) For 3.2 Modulation Characteristics:

C/N	Instrument	Type	S/N	Manufacturer	Date of last calibration	Calibration interval
120121202	Directional Coupler (X-band)	5D364S	R05762	Shimada	10 April 2014	1 year
120121202	Dummy Load (X-band)	4D376	R4535004	Shimada	10 April 2014	1 year
----	Waveguide (for X-band)	WRJ-10 (l = 60 cm)	----	Furuno	----	----
HT654	Step Attenuator	8494B	MY42148134	Agilent	6 March 2015	1 year
HT655	Step Attenuator	8495B	MY42144403	Agilent	6 March 2015	1 year
HT913	Crystal Detector	423B	MY51340543	Agilent	10 February 2015	1 year
HT676	Spectrum Analyzer	8564EC	4103A00440	Agilent	11 March 2015	1 year
HT553	Frequency Counter	53150A	US40501919	Agilent	17 October 2014	1 year
HT972	Oscilloscope	M504054B	C030483	Tektronix	23 March 2015	1 year
HT432	DC Power Supply	PAN55-20	AK003307	KIKUSUI	----	----

(3) For 3.3 Occupied Bandwidth and for 3.5.1 Spurious Emissions at Antenna Terminal:

C/N	Instrument	Type	S/N	Manufacturer	Date of last calibration	Calibration interval
120121202	Directional Coupler (X-band)	5D364S	R05762	Shimada	10 April 2014	1 year
120121202	Dummy Load (X-band)	4D376	R4535004	Shimada	10 April 2014	1 year
----	Waveguide (for X-band)	WRJ-10 (l = 60 cm)	----	Furuno	----	----
HT654	Step Attenuator	8494B	MY42148134	Agilent	6 March 2015	1 year
HT655	Step Attenuator	8495B	MY42144403	Agilent	6 March 2015	1 year
HT676	Spectrum Analyzer	8564EC	4103A00440	Agilent	11 March 2015	1 year
HT432	DC Power Supply	PAN55-20	AK003307	KIKUSUI	----	----

(4) For 3.4 Frequency Stability:

C/N	Instrument	Type	S/N	Manufacturer	Date of last calibration	Calibration interval
HT370	Climatic Chamber (Large)	TBE-3HW5GE2F	3013000995	Espec	18 August 2014	1 year
HT723	Paperless recorder/Dual communication logger DAQSTATION FX100	FX106-4-1	S5JA01445	Yokogawa	18 August 2014	1 year
120121202	Directional Coupler (X-band)	5D364S	R05762	Shimada	10 April 2014	1 year
120121202	Dummy Load (X-band)	4D376	R4535004	Shimada	10 April 2014	1 year
----	Waveguide (for X-band)	WRJ-10 (l = 60 cm)	----	Furuno	----	----
HT654	Step Attenuator	8494B	MY42148134	Agilent	6 March 2015	1 year
HT655	Step Attenuator	8495B	MY42144403	Agilent	6 March 2015	1 year
HT676	Spectrum Analyzer	8564EC	4103A00440	Agilent	11 March 2015	1 year
HT432	DC Power Supply	PAN55-20	AK003307	KIKUSUI	----	----

## (5) For 3.5.2 Field Strength of Spurious Radiation:

C/N	Instrument	Type	S/N	Manufacturer	Date of last calibration	Calibration interval
HT676	Spectrum Analyzer	8564EC	4103A00440	Agilent	11 March 2015	1 year
HT463	Spectrum Analyzer	R3132	110401654	ADVANTEST	1 August 2014	1 year
HT565	Loop Antenna	HFH2-Z2	100093	ROHDE & SCHWARTZ	12 August 2014	1 year
HT459	Biconical antenna (30 MHz to 300 MHz)	VBA6106A	1296	Schaffner	13 August 2014	1 year
HT331	Log periodic antenna (300 MHz to 1000 MHz)	UHALP9107	91071214	Schwarzbeck	13 August 2014	1 year
HT467	Double-ridged waveguide horn antenna (1 GHz to 18 GHz)	3115	6520	EMCO	12 August 2014	1 year
HT761	Double rigged horn antenna & amp.	HAP18-26N	00000017	TOYO	29 December 2014	1 year
HT762	Double rigged horn antenna & amp.	HAP26-40N	00000010	TOYO	29 December 2014	1 year
HT518	Pre-amplifier (30 MHz to 2 GHz)	87405A	3207A01643	Agilent	23 June 2014	1 year
HT568	Amplifier (for Loop antenna)	310N	250607	Sonoma Instrument	23 June 2014	1 year
HT365	Semi-anechoic Chamber	3mSAC	D-002	Riken	----	----
HT156	DC power supply	GP035-30	1014396080	Takasago	----	----
30-0021	Notch Filter (X-band)	CBR-X7-3A	R986500	Shimada	17 September 2014	1 year
---	Dummy Load (X-band)	4D376	R25510001	Shimada	----	----
KB137	Coaxial cable	MWX221-2m	0804S167	JUNKOSHA	19 September 2014	1 year
KB138	Coaxial cable	MWX221-5m	0804S166	JUNKOSHA	19 September 2014	1 year
KB179	Coaxial Cable for Radiated Emission Measurement	SUCOFLEX 104A	48932/4A	HUBER+SUHNER	9 August 2014	1 year
KB180	Coaxial Cable for Radiated Emission Measurement	SUCOFLEX 104A	48933/4A	HUBER+SUHNER	9 August 2014	1 year
KB181	Coaxial Cable for Radiated Emission Measurement	SUCOFLEX 102A	1261/2A	HUBER+SUHNER	9 August 2014	1 year

## (6) For 3.6 Suppression of Interference Aboard Ships:

C/N	Instrument	Type	S/N	Manufacturer	Date of last calibration	Calibration interval
HT676	Spectrum Analyzer	8564EC	4103A00440	Agilent	11 March 2015	1 year
HT432	DC Power Supply	PAN55-20	AK003307	KIKUSUI	----	----

## 6 Photograph of Test Setup/Arrangement

(1) For Temperature (TX frequency stability) tests,

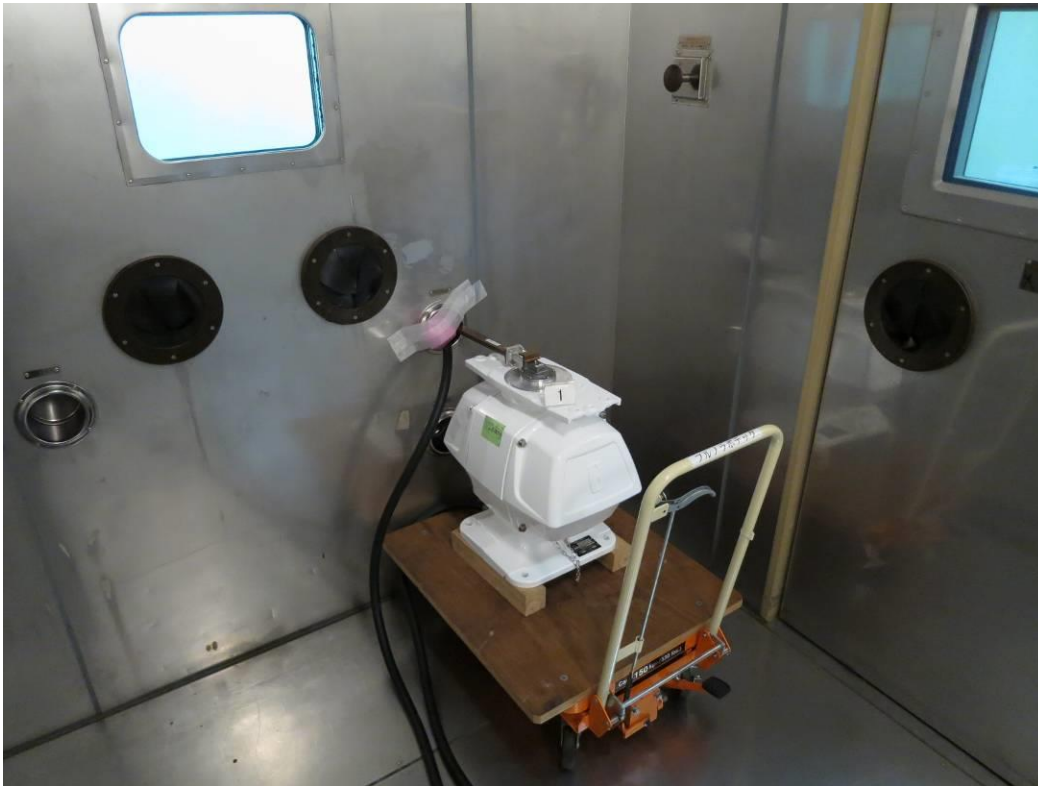

(2) For Transmitter Unwanted Emissions measurements,



for 9 kHz to 2000 MHz



for 2 GHz to 40 GHz

### 7 RF Envelope and Spectrum of the output pulse

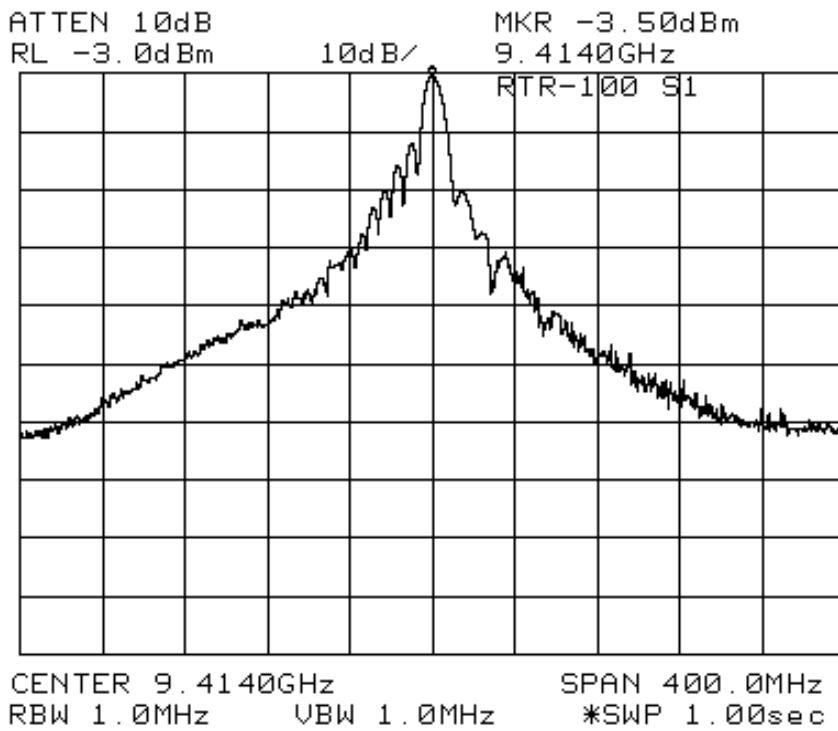
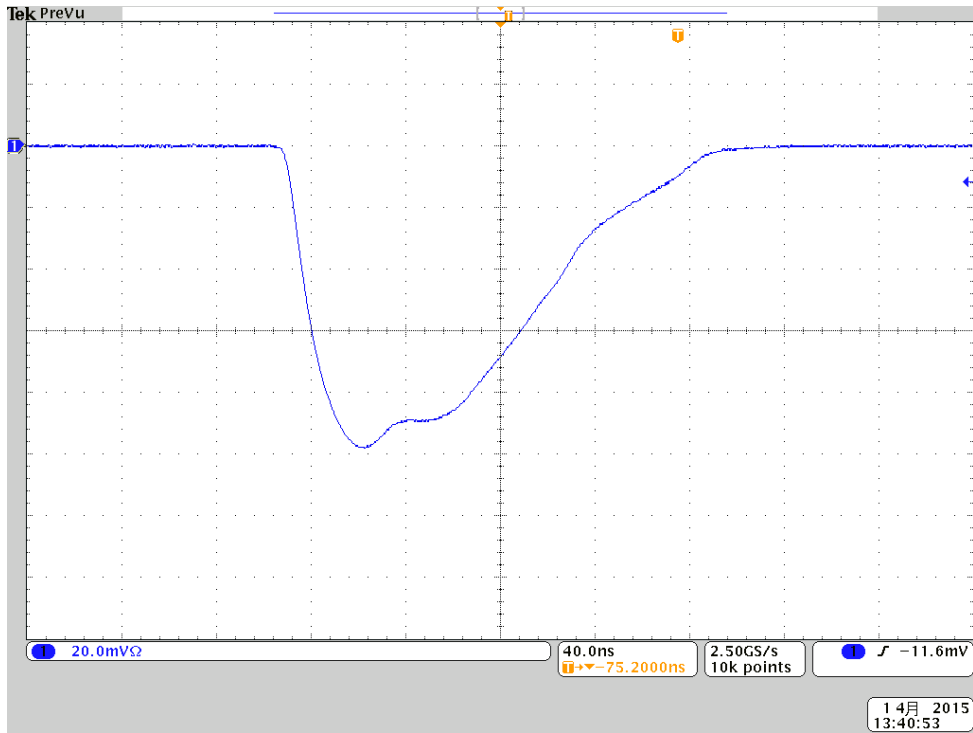

Fig. 7.1 S1 Pulse Envelope and Spectrum

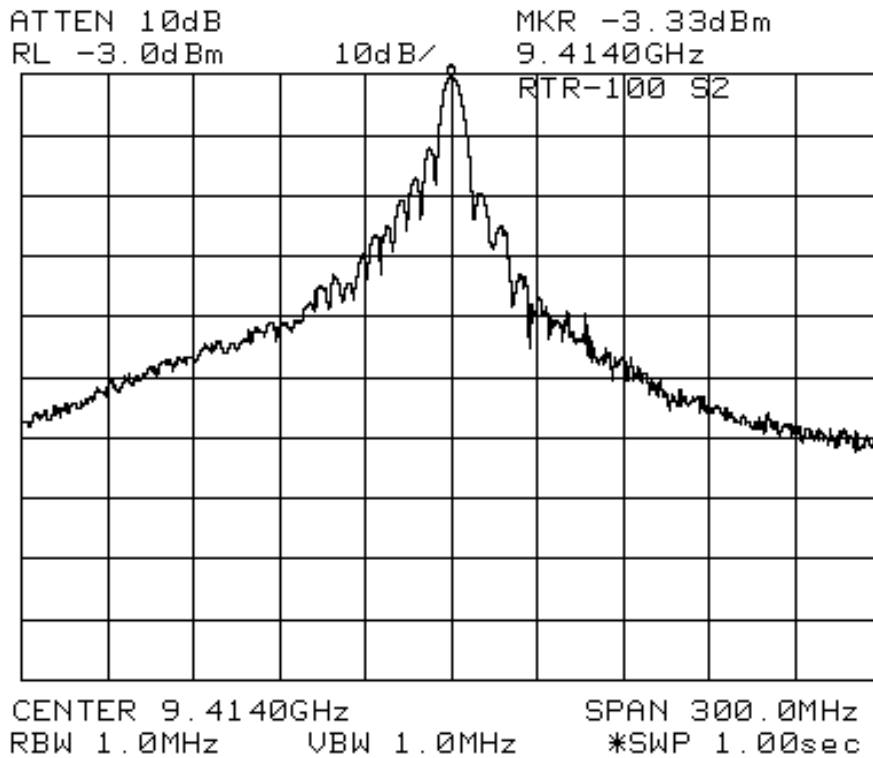
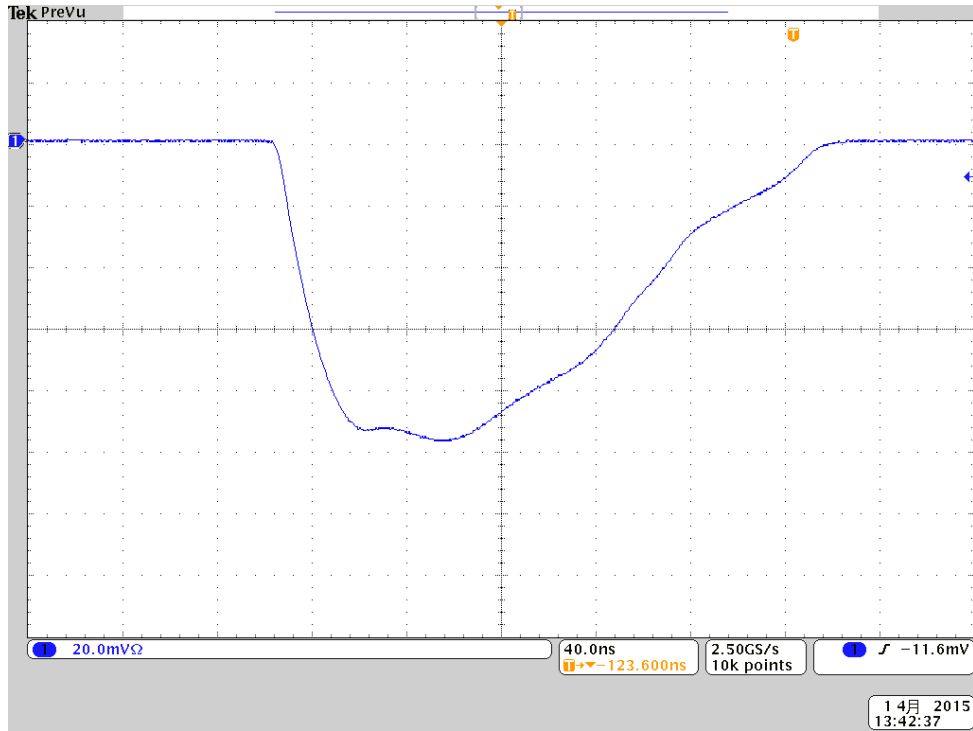

Fig. 7.2 S2 Pulse Envelope and Spectrum

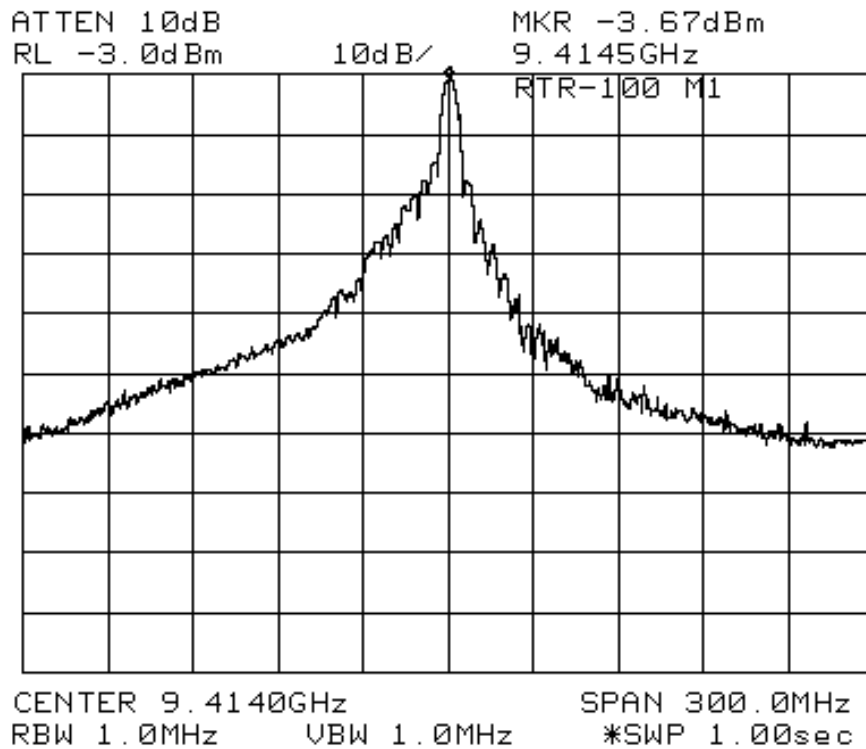
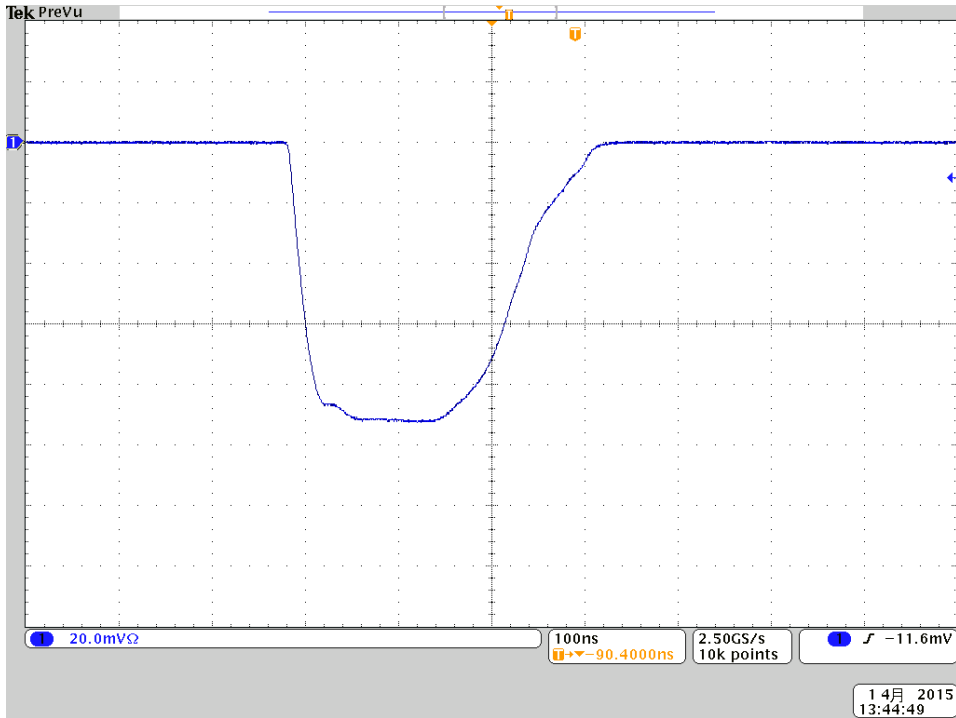

Fig. 7.3 M1 Pulse Envelope and Spectrum



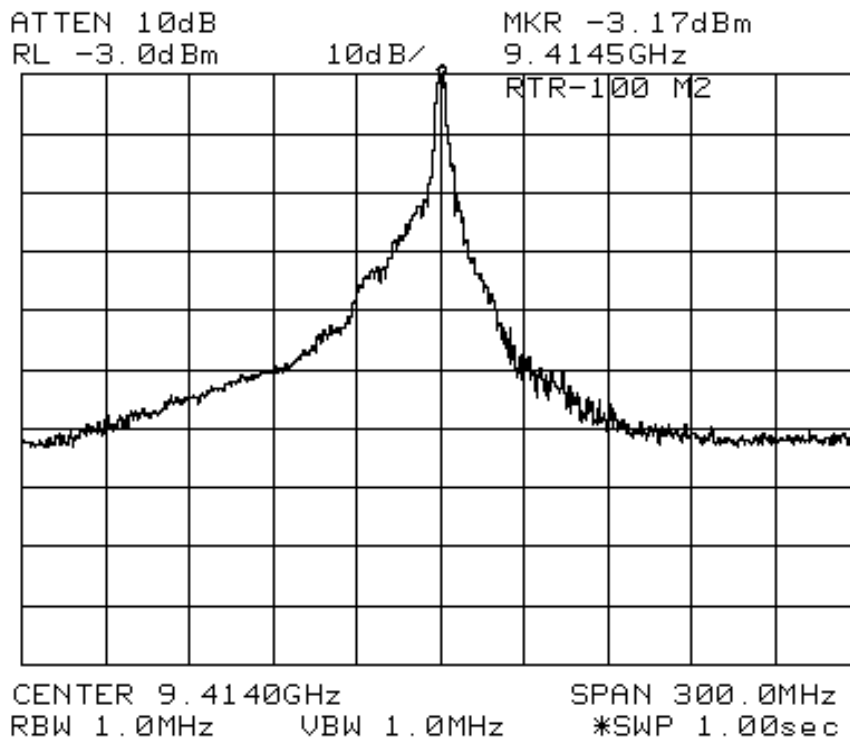
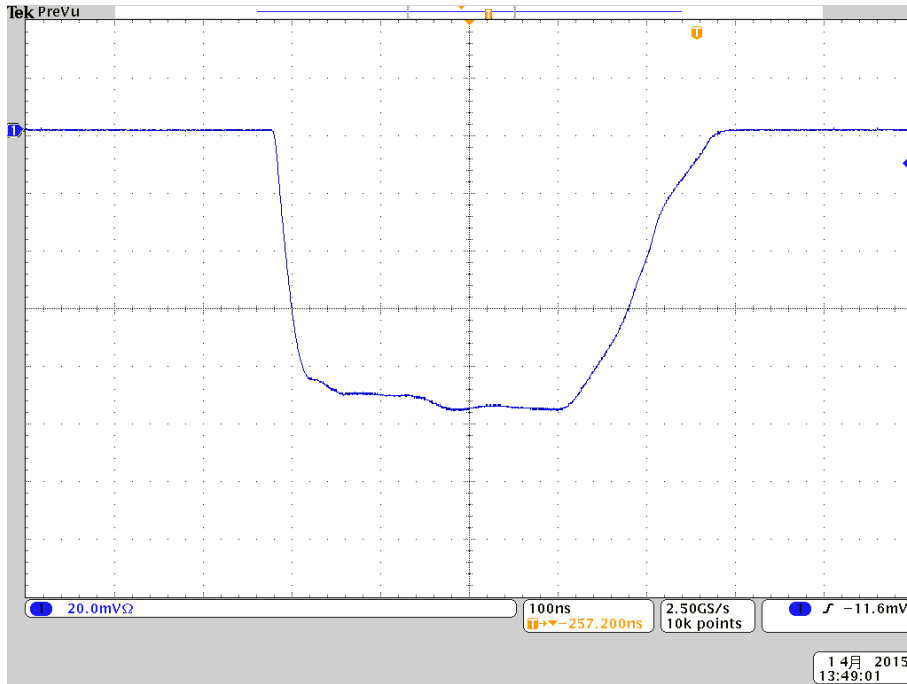

Fig. 7.4

M2 Pulse Envelope and Spectrum

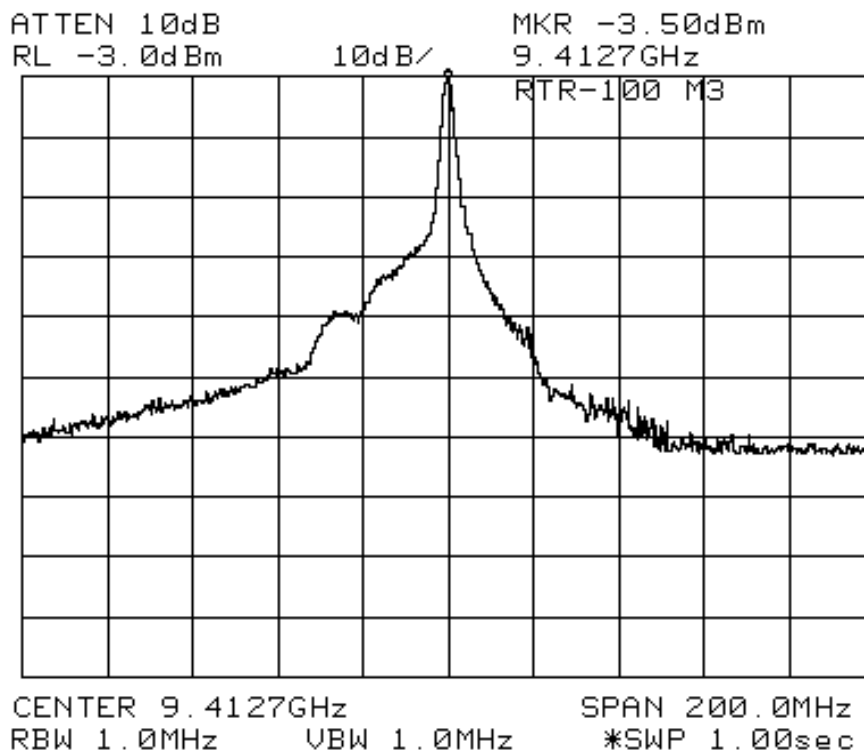
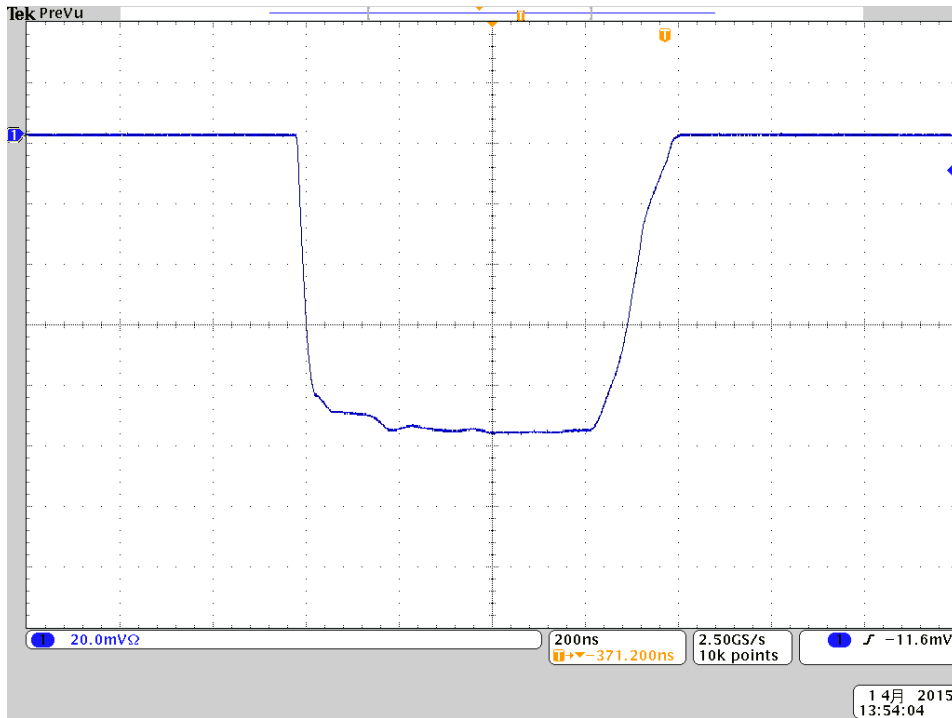

Fig. 7.5 M3 Pulse Envelope and Spectrum

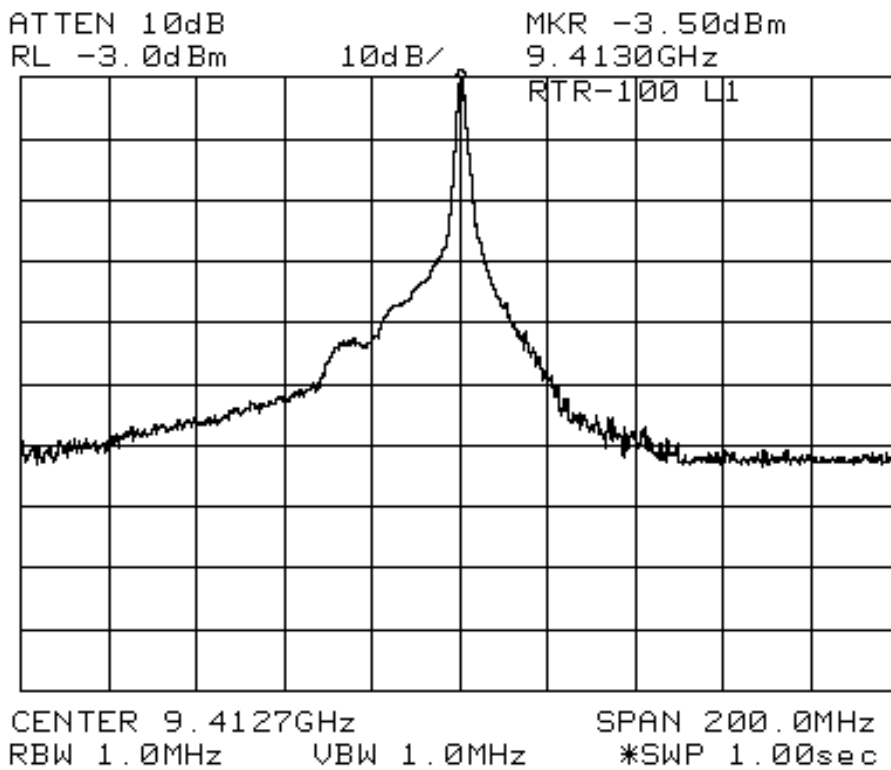
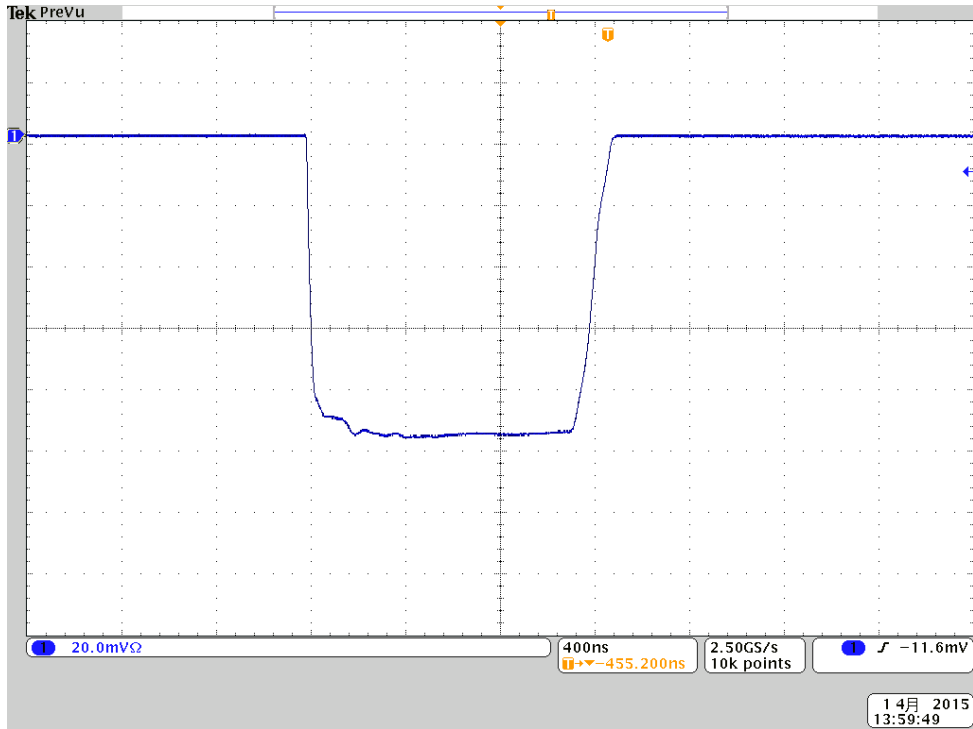

Fig. 7.6 L1 Pulse Envelope and Spectrum

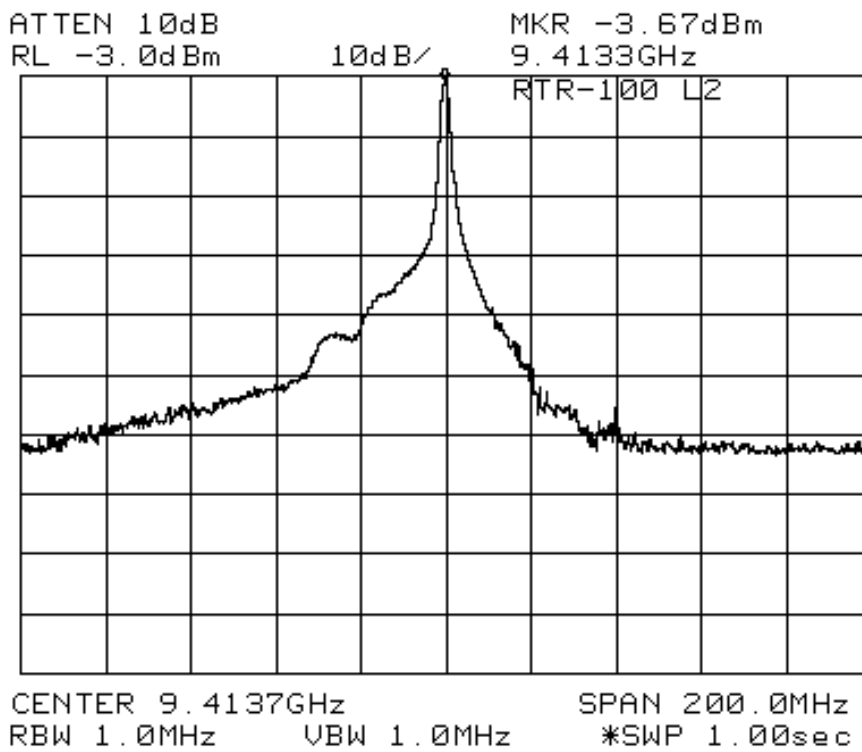
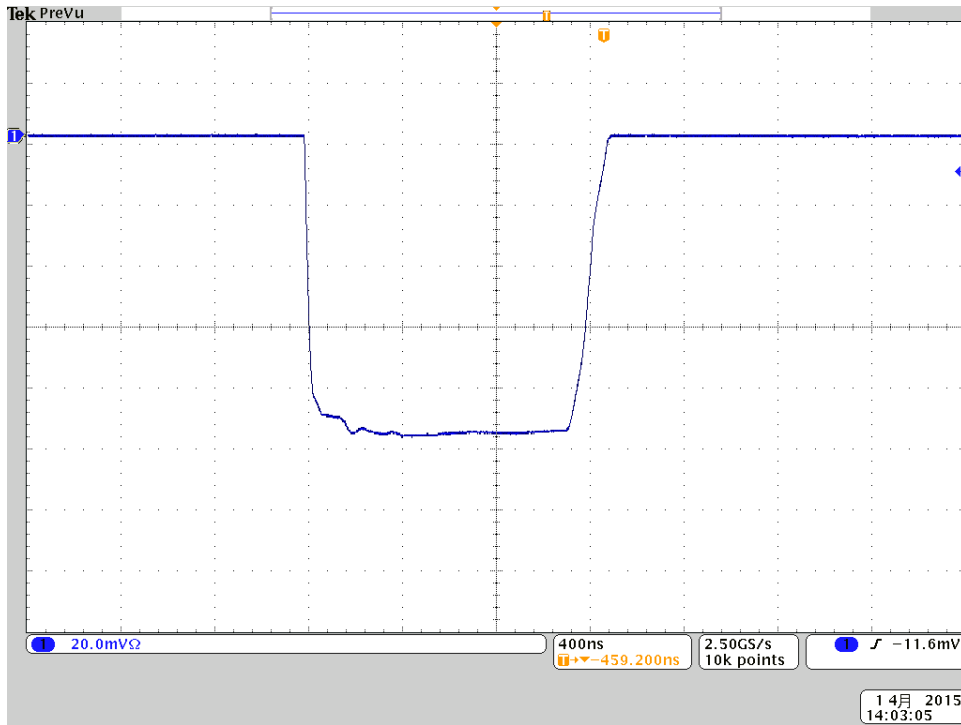

Fig. 7.7 L2 Pulse Envelope and Spectrum

## 8 Spurious Emission Plots measured at Antenna Terminal

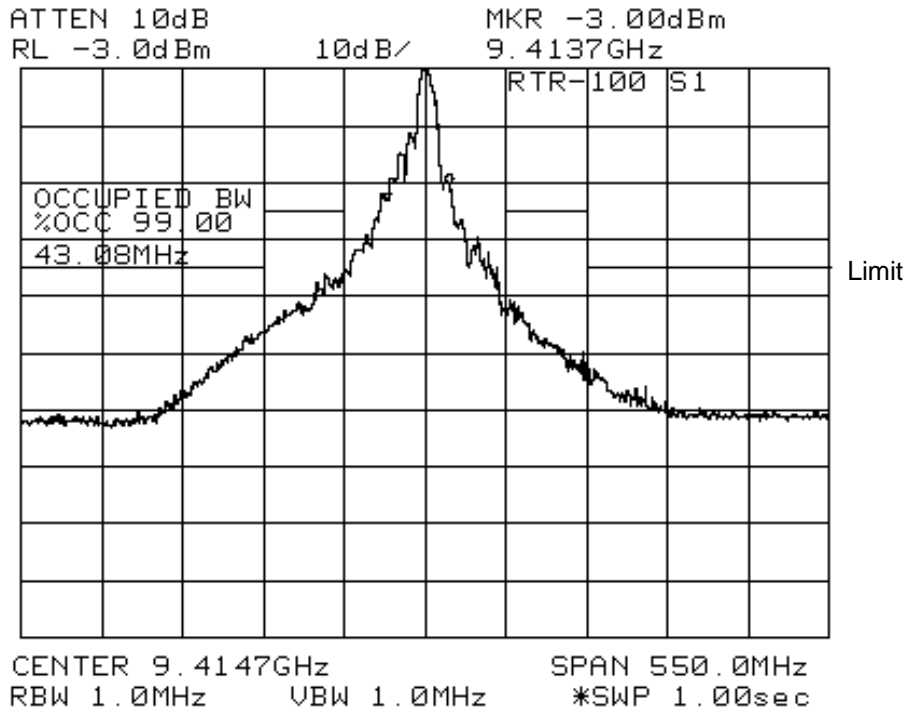

Fig. 8.1 for S1 Pulse

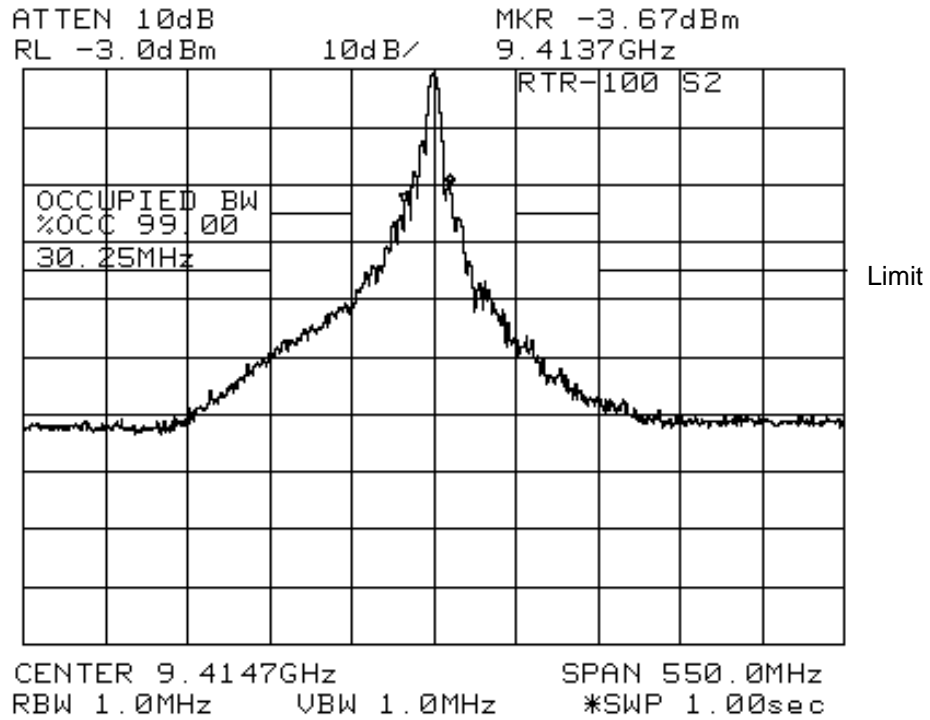

Fig. 8.2 for S2 Pulse



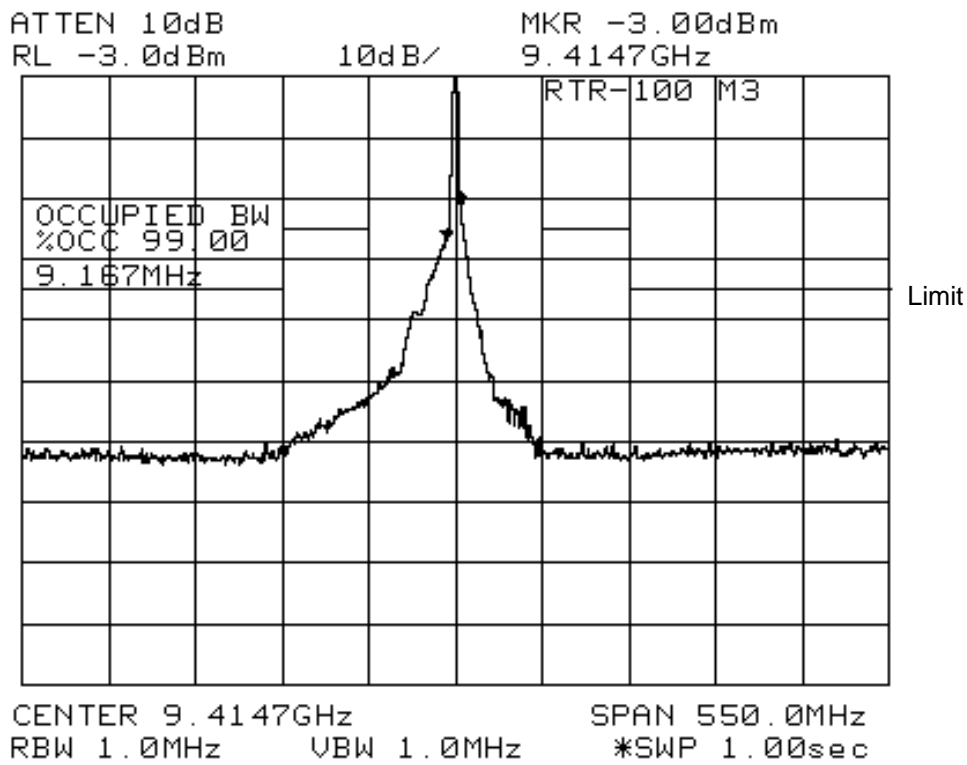

Fig. 8.5 for M3 Pulse

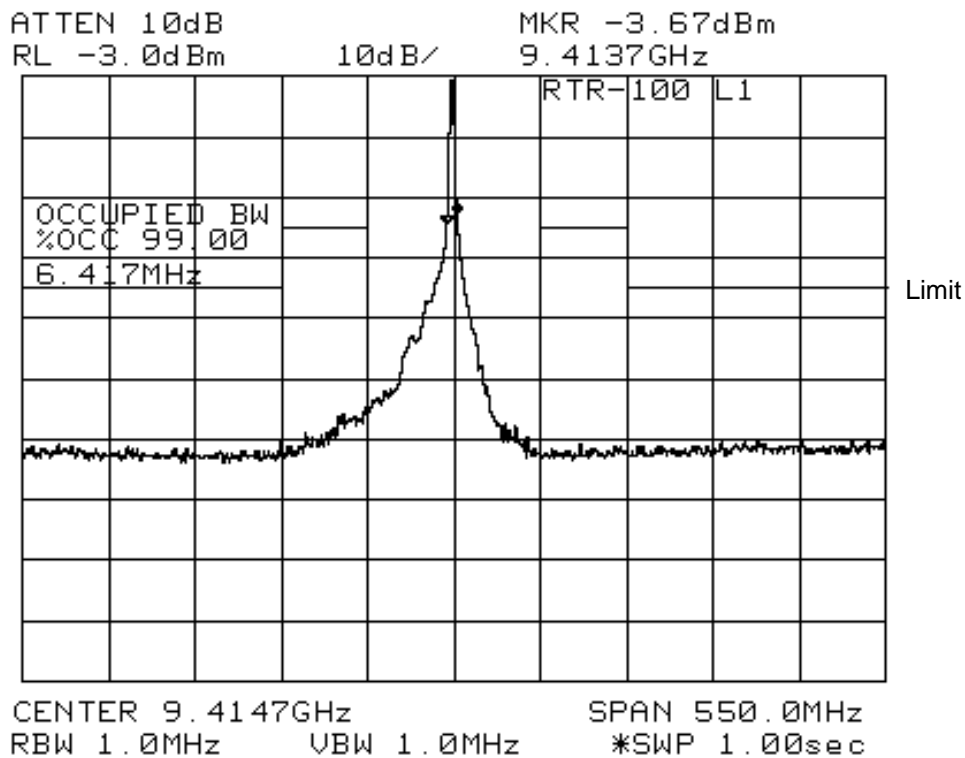

Fig. 8.6 for L1 Pulse

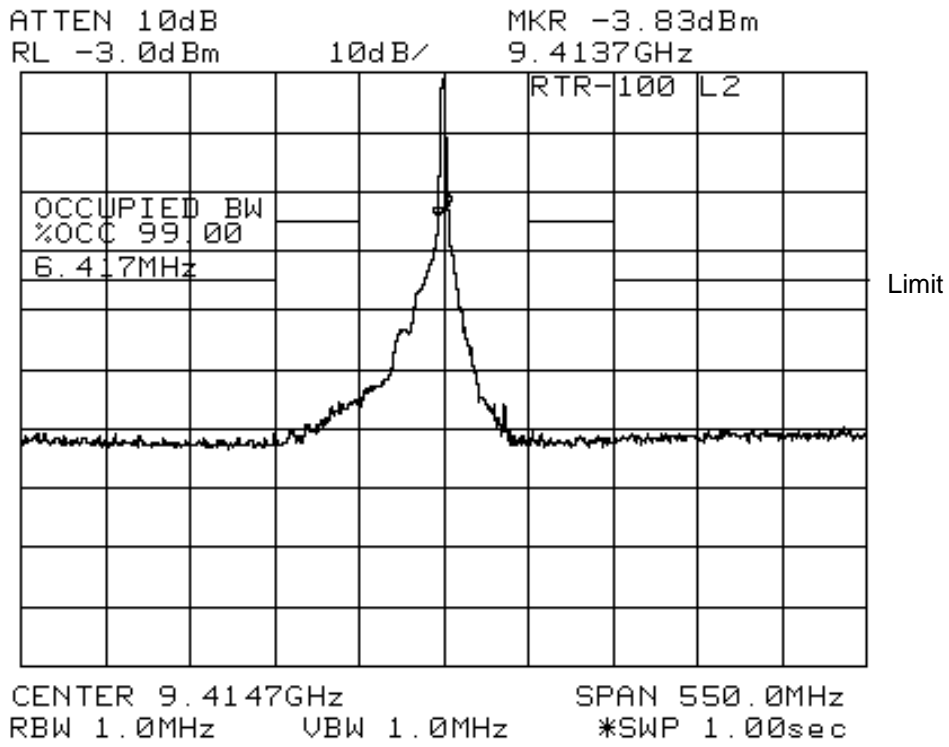

Fig. 8.7 for L2 Pulse



## 9 Field Strength Plots of Spurious Radiation

### 9.1 Maximum power radiation level

#### 9.1.1 for S1 Pulse and XN20AF

(1) for Horizontal

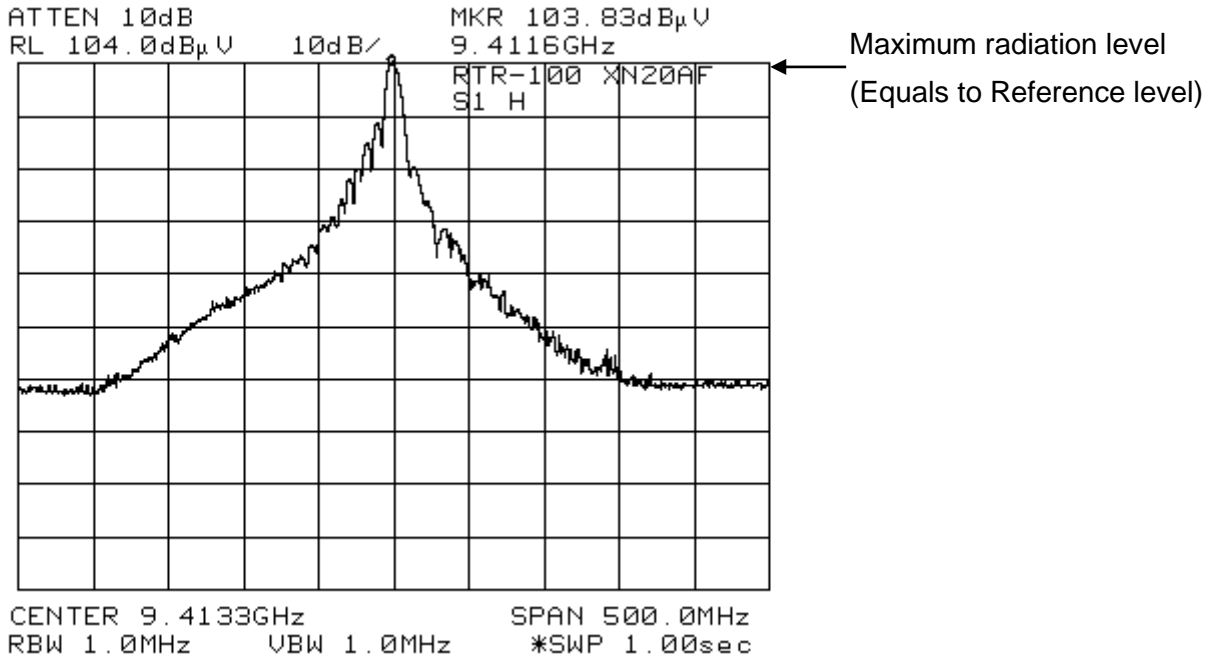

(2) for Vertical

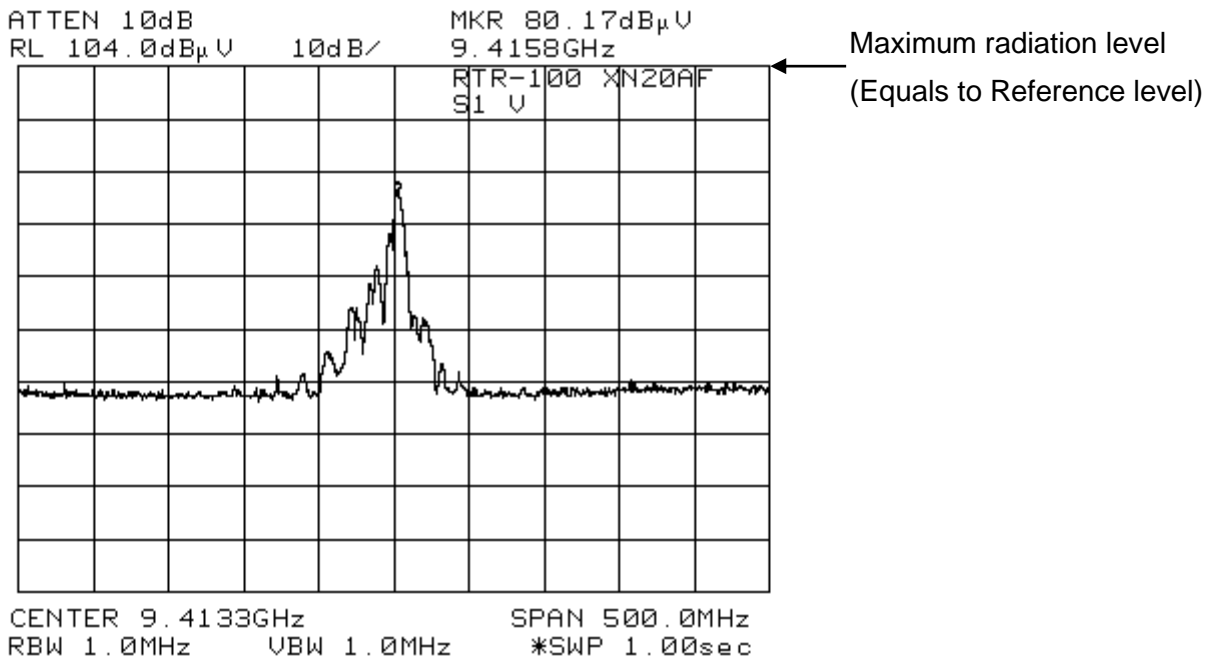

For the maximum power radiation level, the voltage value measured by the spectrum analyzer was converted into the electric field strength with the measuring antenna factor, Cable loss and Amp. gain.

Maximum power radiation level = 165.6 dBμV/m

Therefore, Emission Limit = 165.6 dBμV/m - 60 dB = 105.6 dBμV/m

**9.2 Spurious emissions**

**9.2.1 for S1 pulse,**

(1) for 9 kHz to 30 MHz

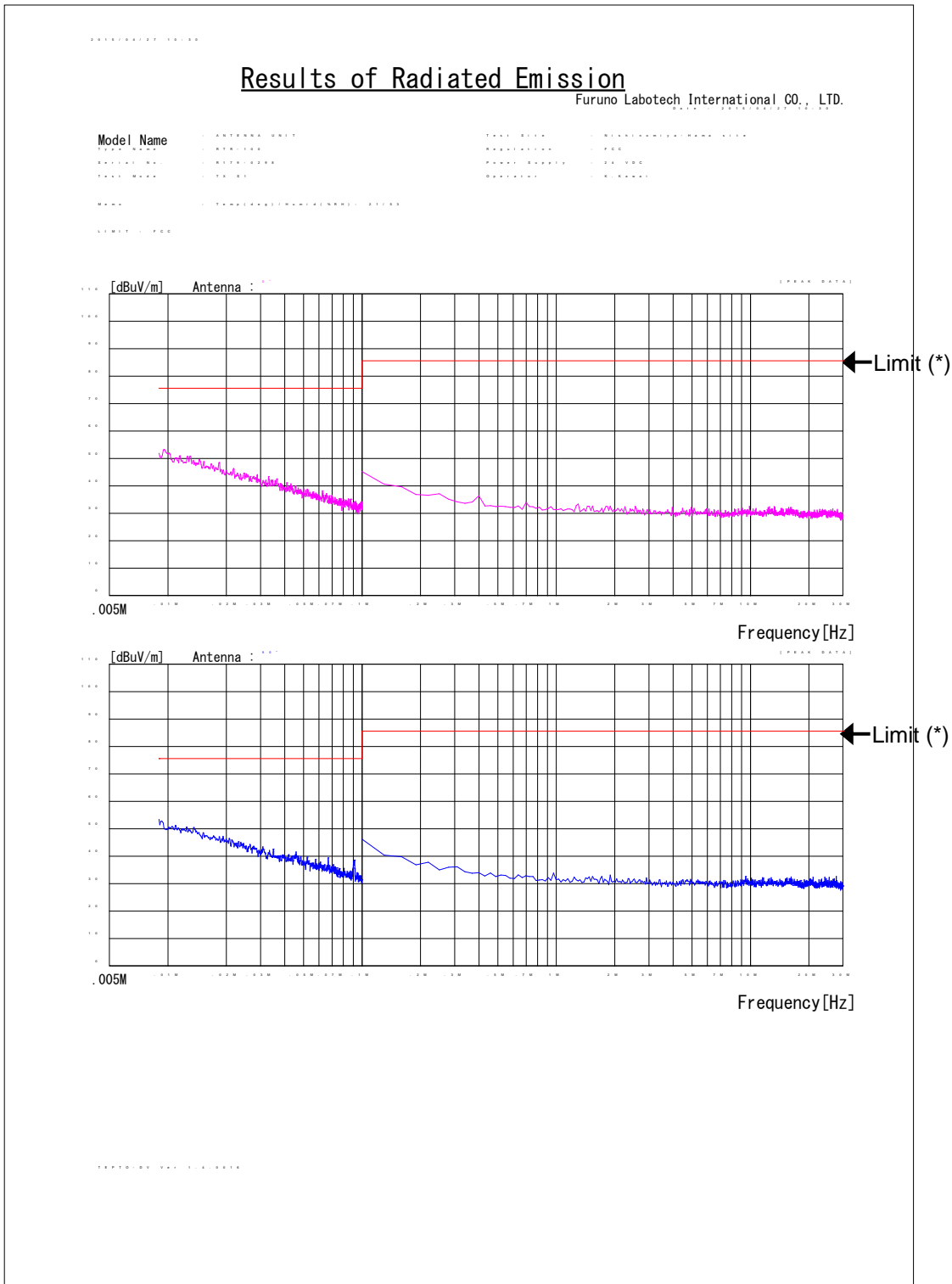

(\*): The resolution bandwidth of the spectrum analyzer for the frequency range of 9 kHz to 100 kHz was set to 1 kHz, and to 10 kHz for 100 kHz to 30 MHz, instead of 1 MHz for the frequency range of 2 GHz to 40 GHz. The applicable limit was set at 30 dB lower than that computed in Clause 9.1 for the former frequency range, and 20 dB lower for the latter frequency range.

(2) for 30 MHz to 2000 MHz

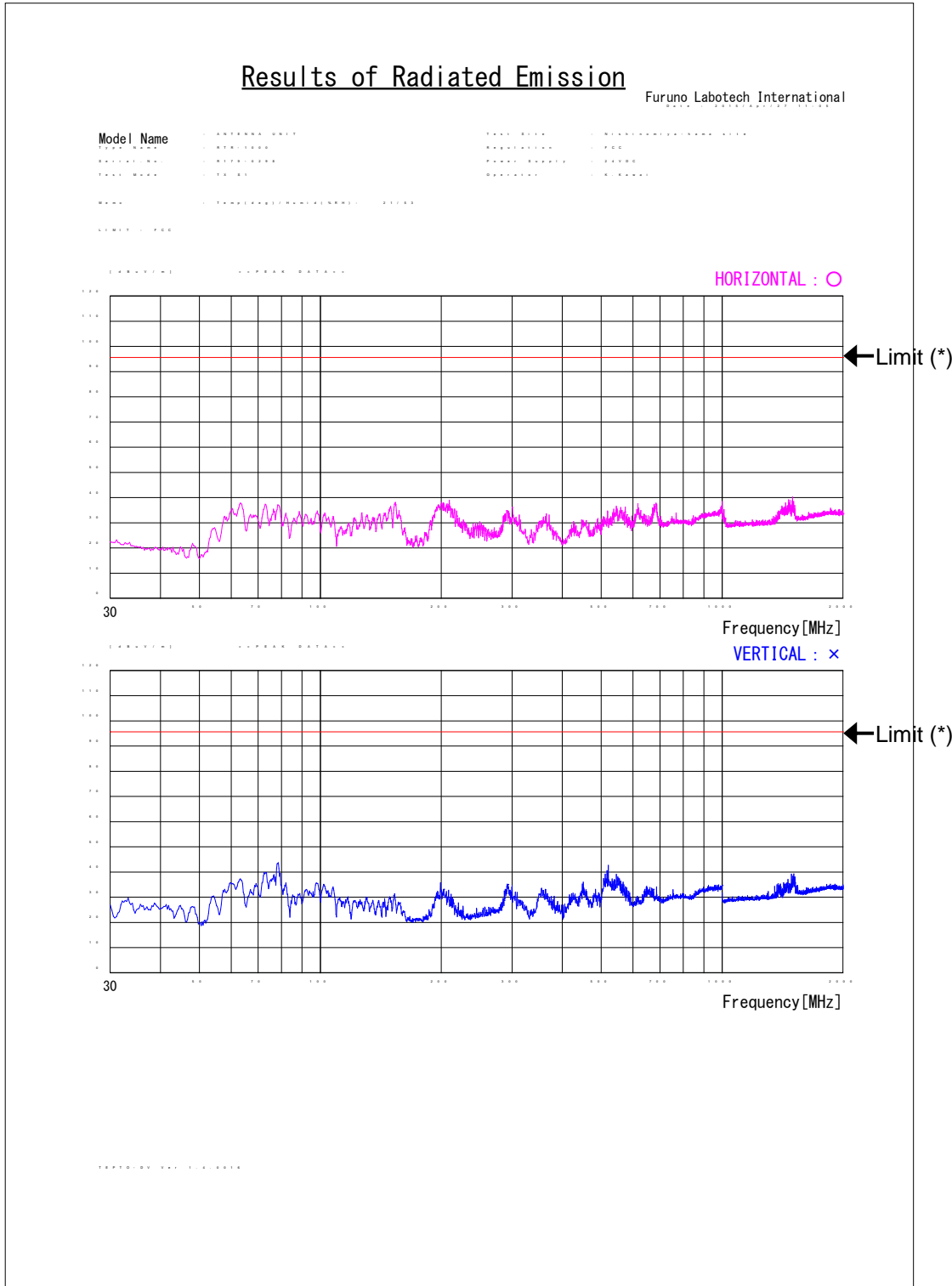

(\*): The resolution bandwidth of the spectrum analyzer for the frequency range of 30 MHz to 2000 MHz was set to 100 kHz instead of 1 MHz for the frequency range of 2 GHz to 40 GHz. The applicable limit was set at 10 dB lower than that computed in Clause 9.1.

(3) for 2 GHz to 18 GHz

- for Horizontal

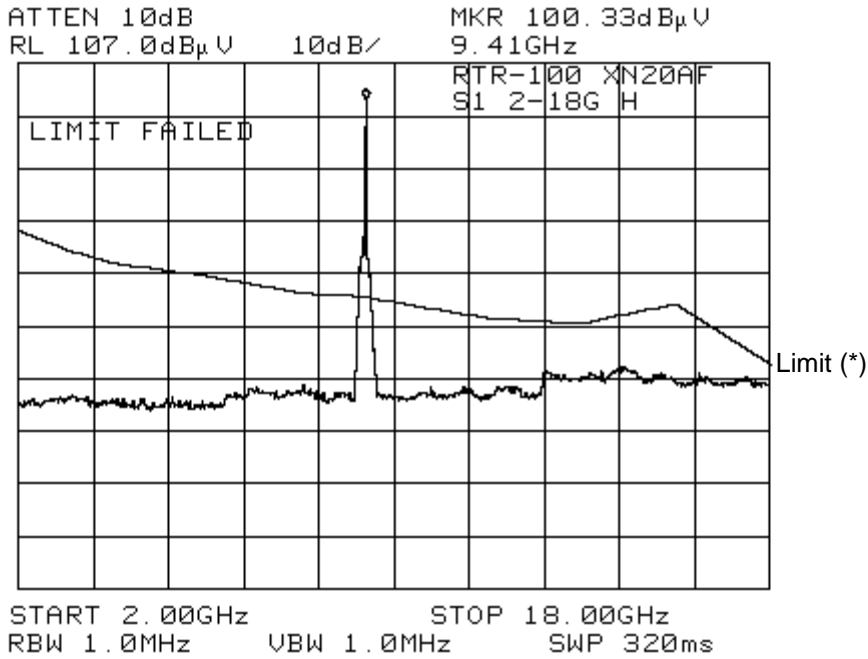

- for Vertical

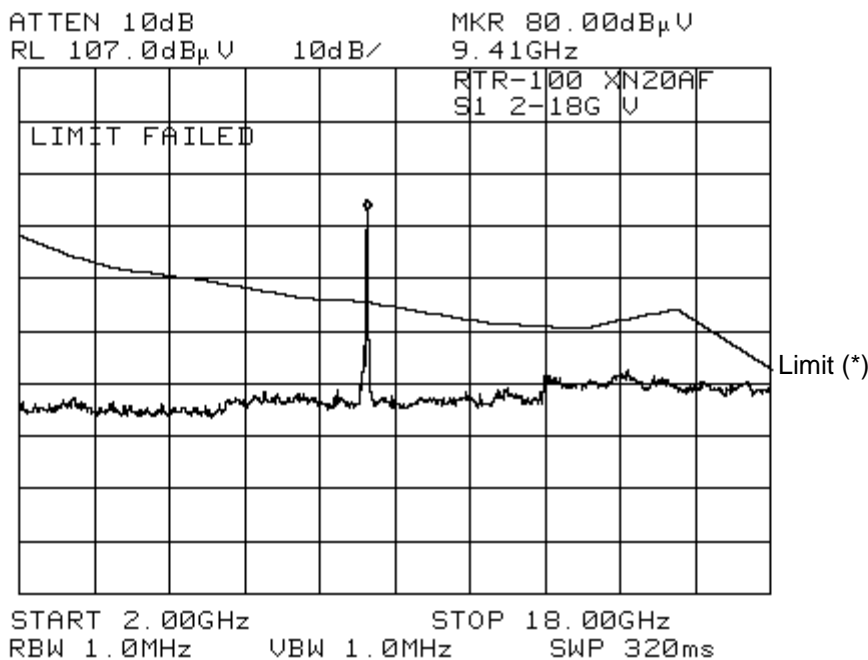

The notch filter ( Pass band: 9410 ± 150 MHz) was inserted between the measuring antenna and Spectrum Analyzer to prevent the excessive input to Spectrum Analyzer only for the test frequency range of 2 GHz to 18 GHz.

(\*) The Limit is represented by the voltage value, which was derived from the electric field strength value with Antenna factor, Cable loss and Amp. gain included.

(4) for 18 GHz to 26.5 GHz

- for Horizontal

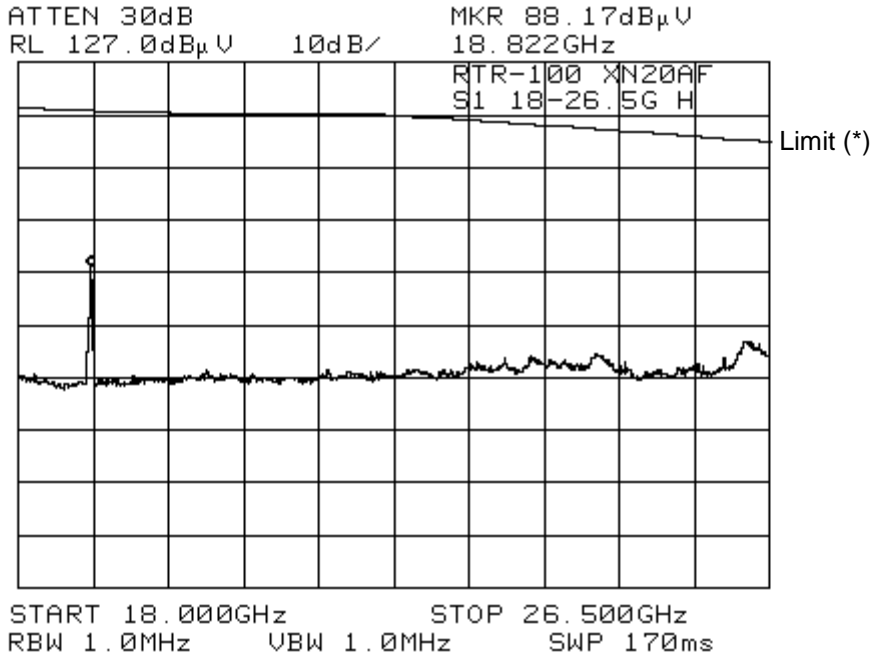

- for Vertical

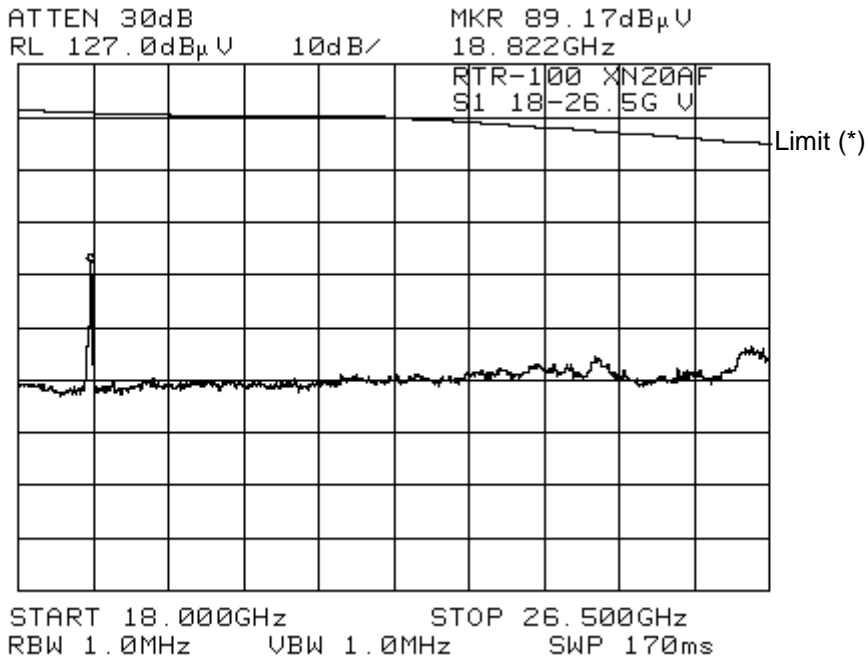

(\*) The Limit is represented by the voltage value, which was derived from the electric field strength value with Antenna factor, Cable loss and Amp. gain.

Minimum limit line for the frequency range of 18 GHz to 26.5 GHz is indicated in the above plots.

(5) for 26.5 GHz to 40 GHz

- for Horizontal

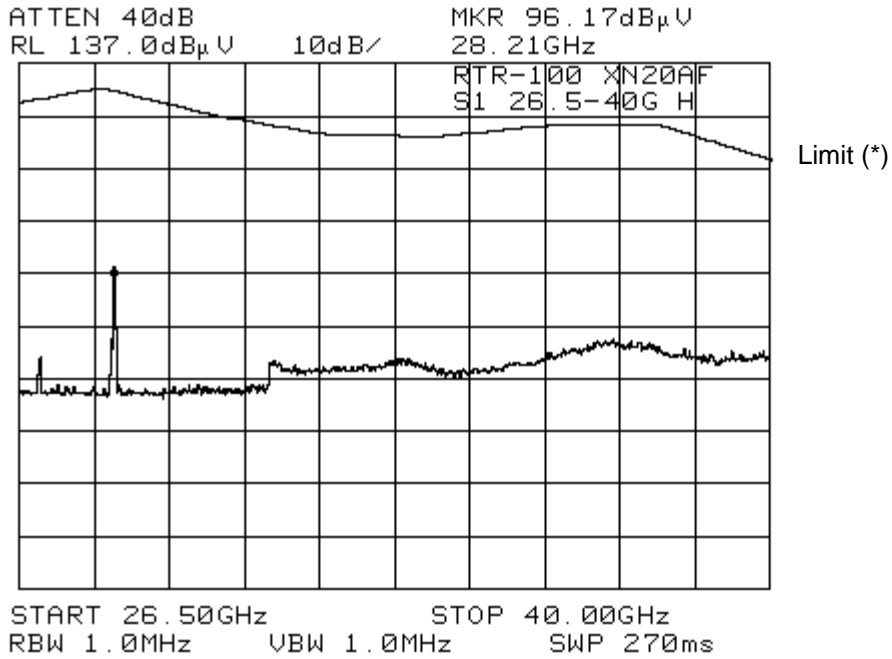

- for Vertical

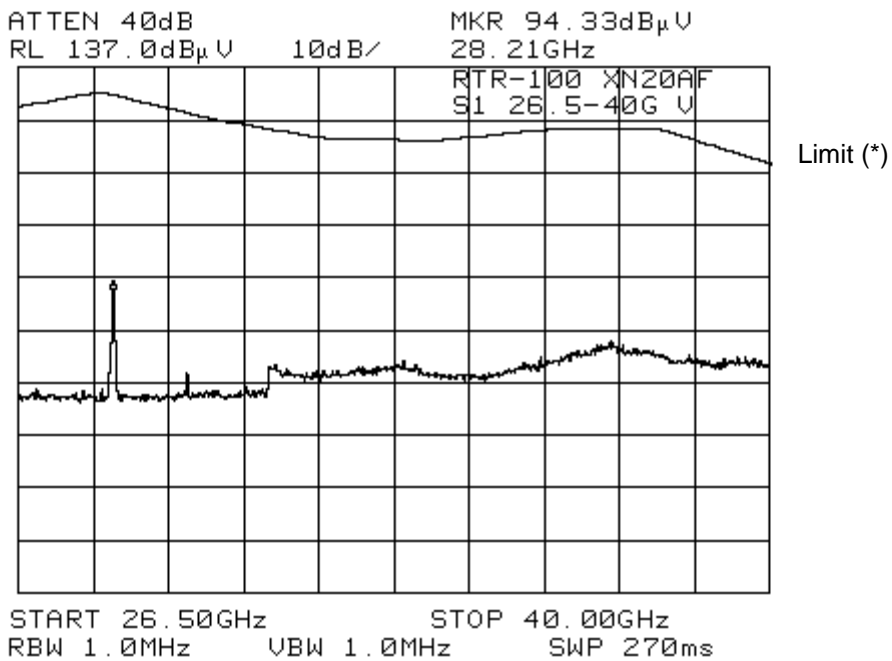

(\*): Emission limit was converted from the electric field strength into the voltage values with Antenna factor, Cable loss and Amp. gain added to the calculation.  
Minimum limit line for the frequency range of 26.5 GHz to 40 GHz is indicated in the above plots.

## 10 Field Strength Plots for Suppression of Interference Aboard Ships

(1) 9 kHz – 150 kHz: Limit = 400  $\mu$ W (-4 dBm)

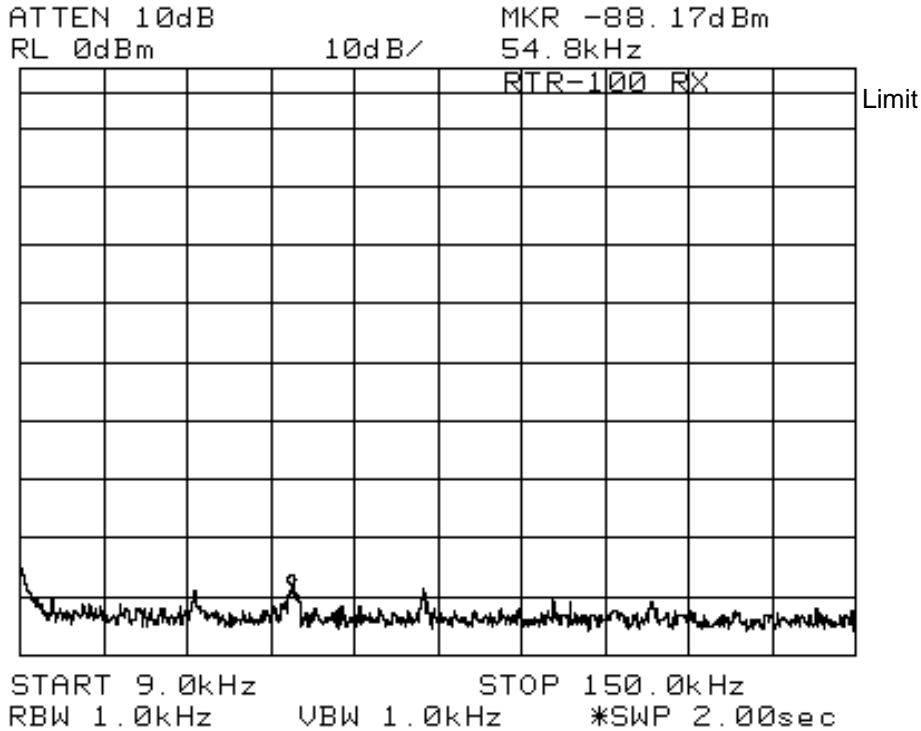

(2) 150 kHz – 30 MHz: Limit = 400  $\mu$ W (-4 dBm)

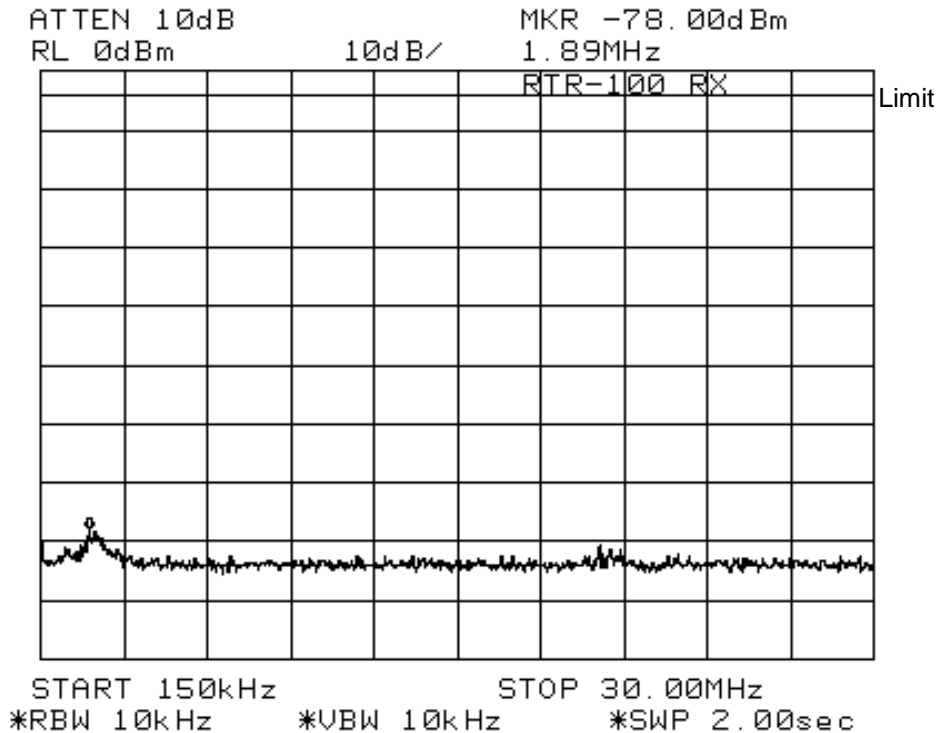

(3) 30 MHz – 100 MHz: Limit = 4000 μW (+6 dBm)

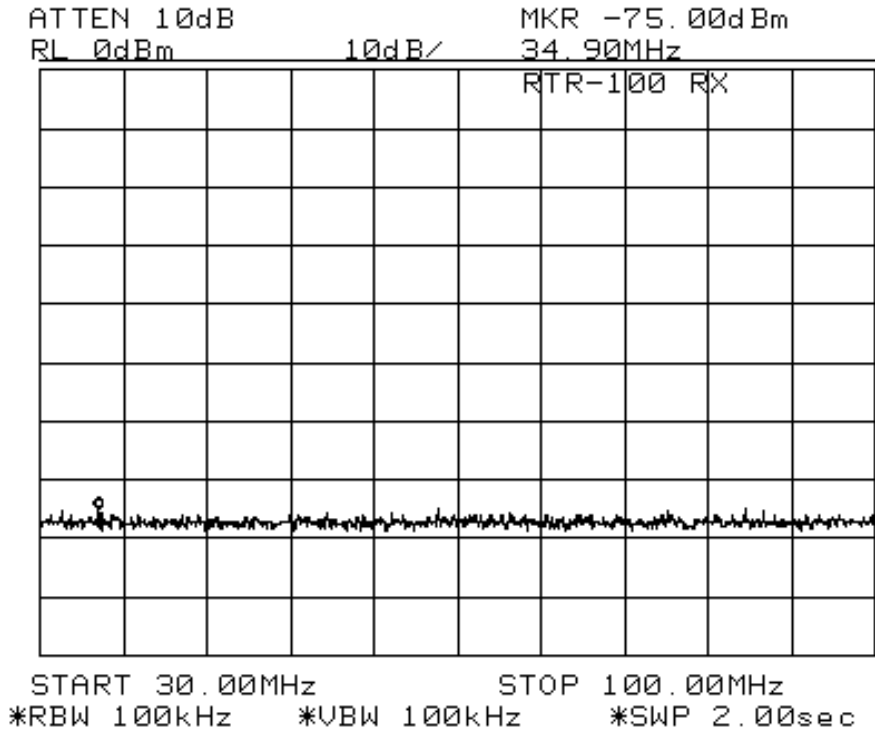

(4) 100 MHz – 300 MHz: Limit = 40000 μW (+16 dBm)

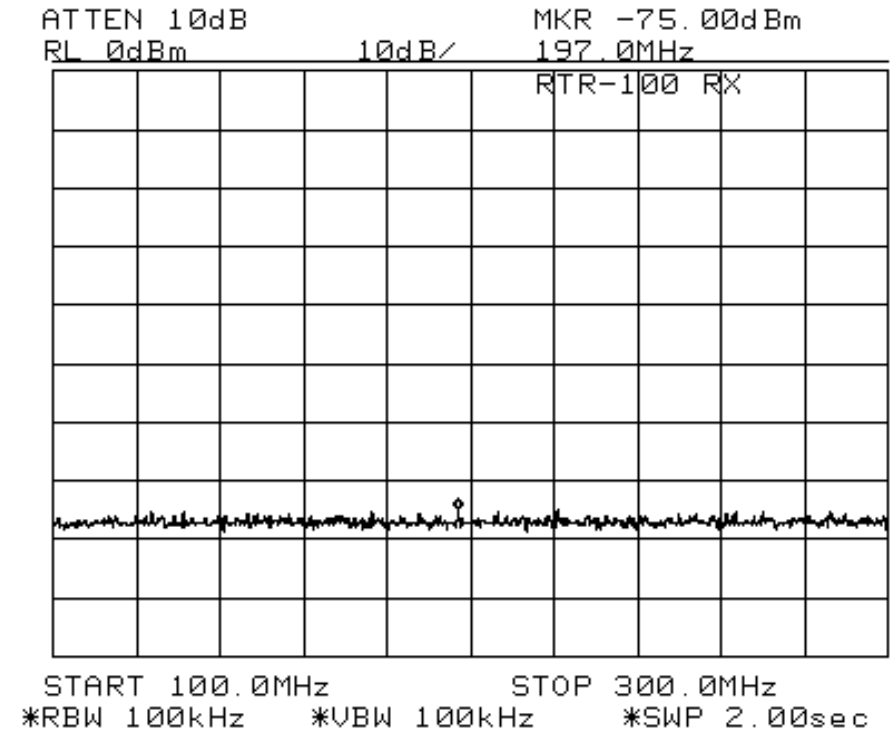



(5) 300 MHz – 1 GHz: Limit = 400000 μW (+26 dBm)

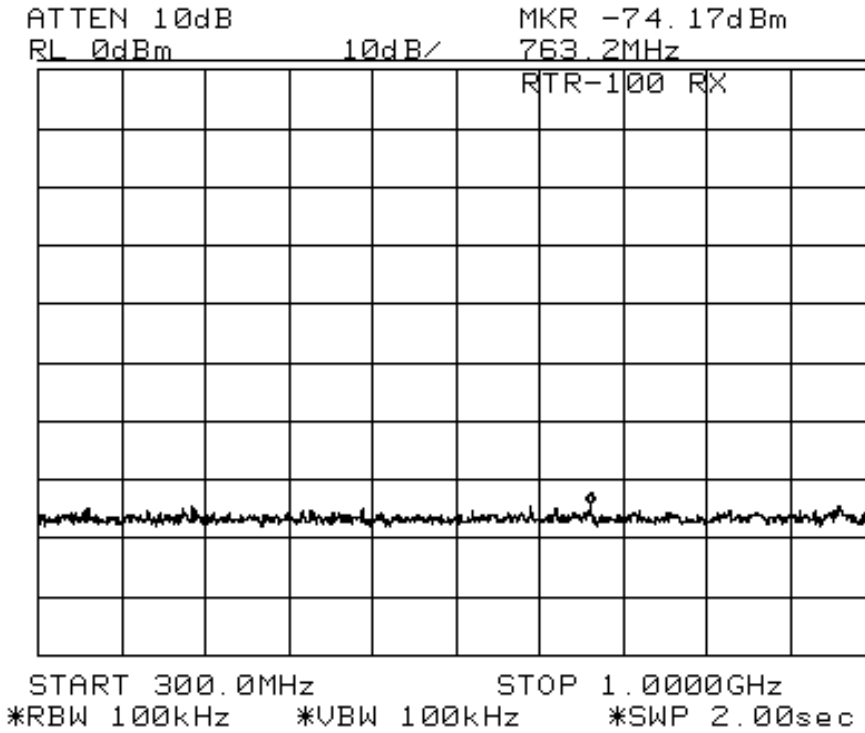

(6) 1 GHz – 10 GHz: Limit = 400000 μW (+26 dBm)

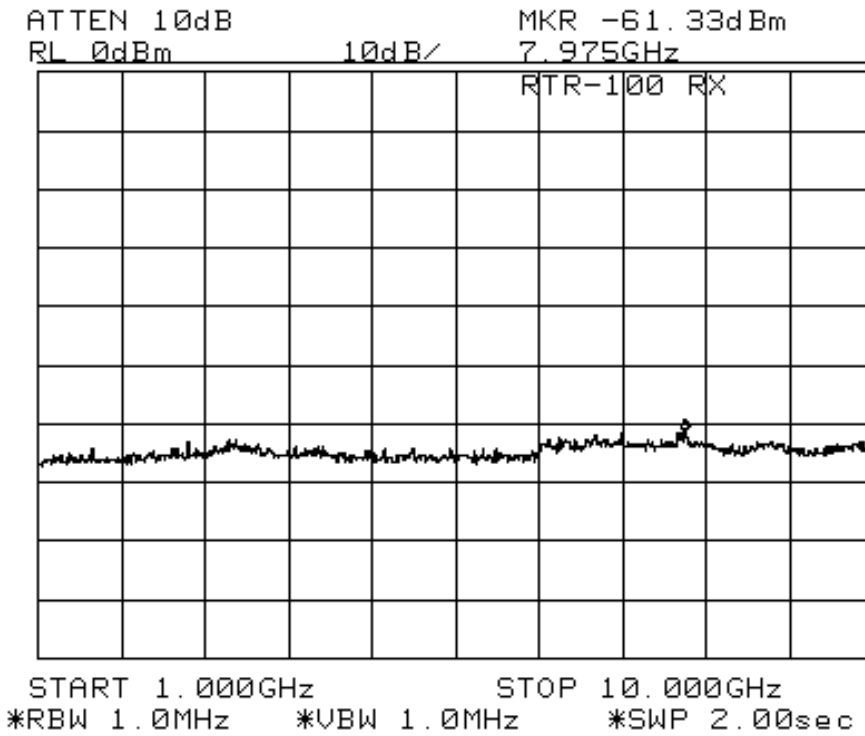

(7) 10 GHz – 18 GHz: Limit = 400000 μW (+26 dBm)

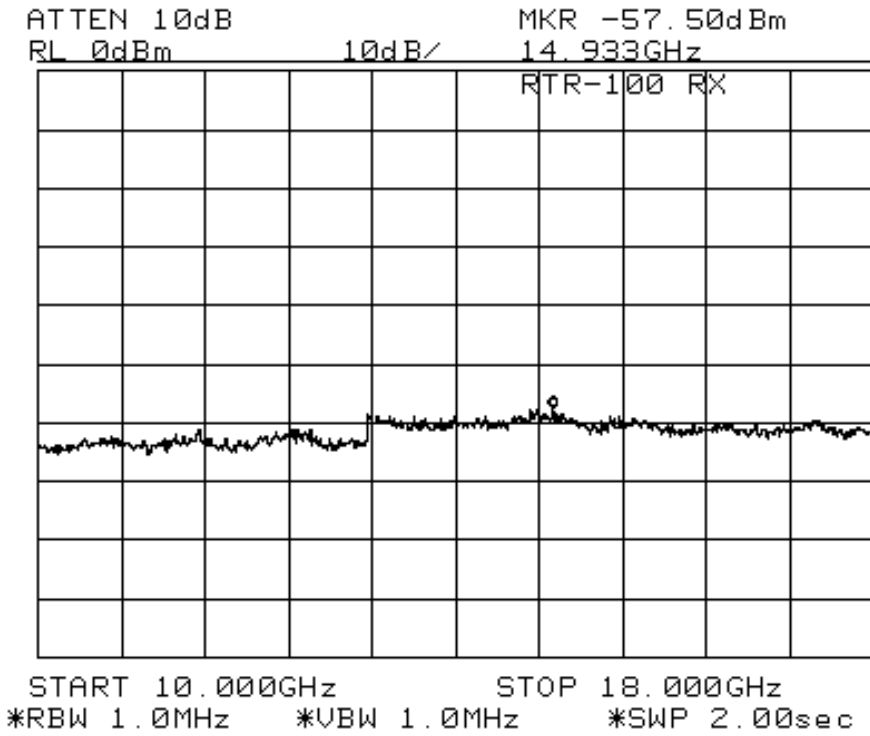

(8) 18 GHz – 26.5 GHz: Limit = 400000 μW (+26 dBm)

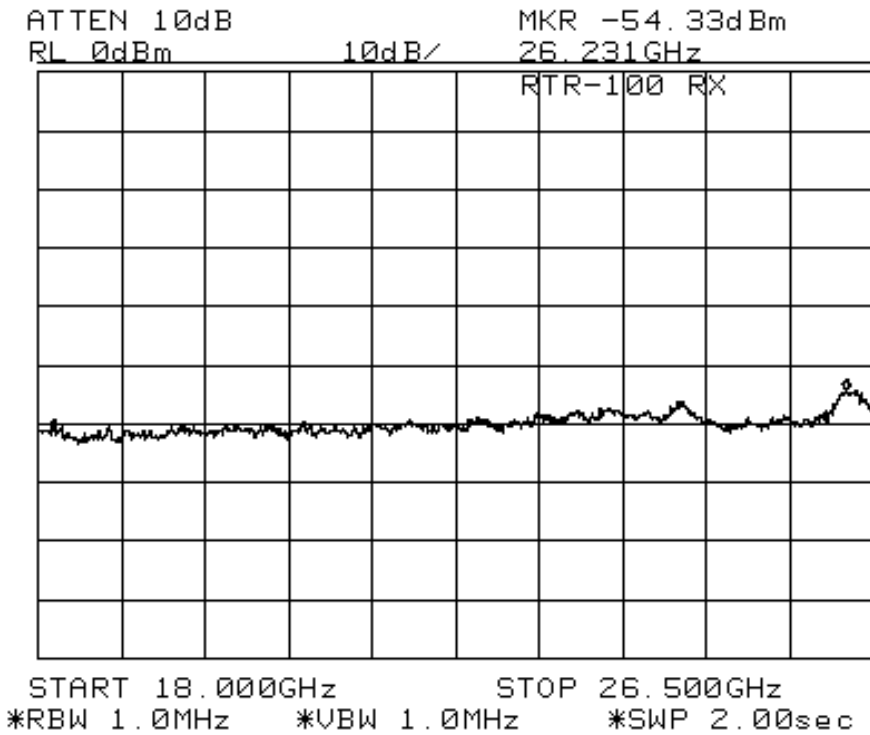

(9) 26.5 GHz – 33 GHz: Limit = 400000 µW (+26 dBm)

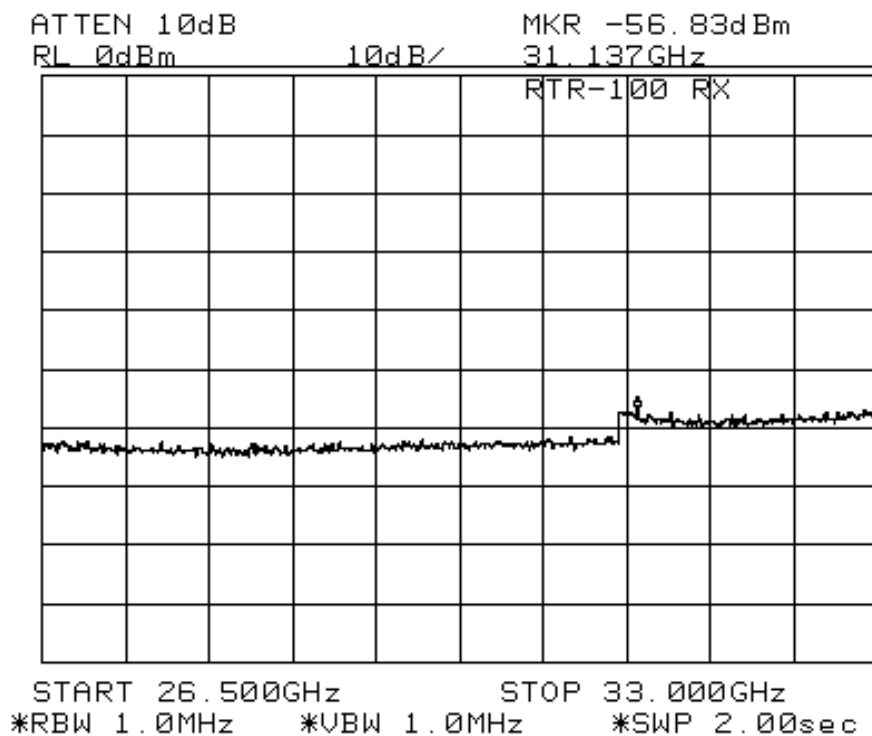

(10) 33 GHz – 40 GHz: Limit = 400000 µW (+26 dBm)

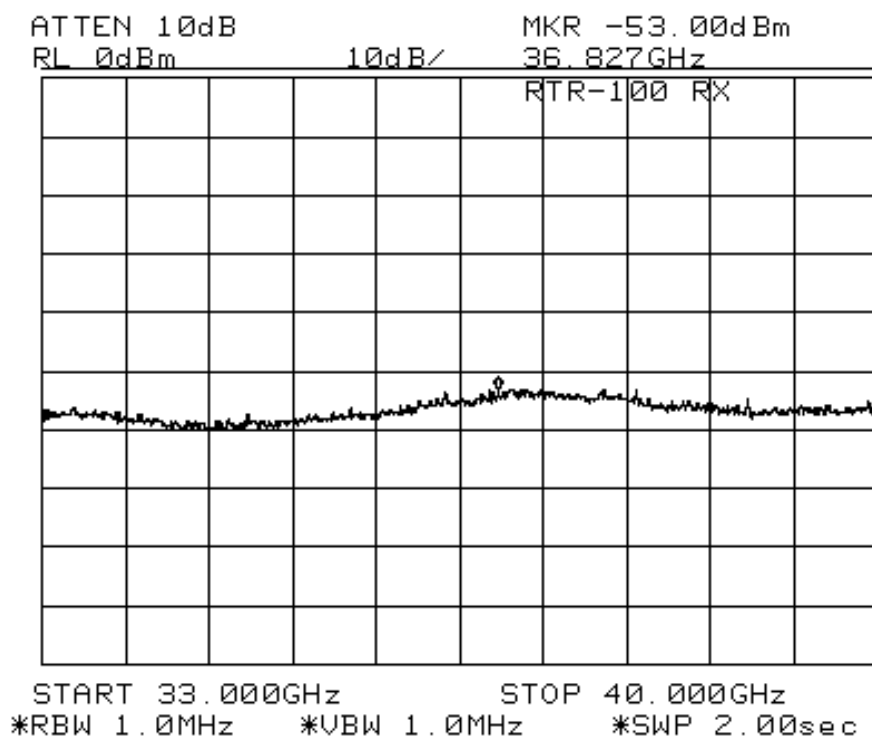

End of text