

# Test Report

(FCC Rules 2.1046/2.1047/2.1049/2.1051/2.1053/2.1055/80.217)

**For**

**Trade name: Furuno  
Model: Transceiver for Marine Radar  
Type: RTR-079A**

**Report no.: FLI 12-11-015  
Date of issue: 9 February 2011**

**Furuno Labotech International Co., Ltd.**  
9-52 Ashihara-cho, Nishinomiya City, Hyogo 662-8580, Japan  
Tel: +81-798-63-1094 Fax: +81-798-63-1098

## Report Summary

FLI project number:	FLI 04-10-0290					
Test report number of initial issue:	FLI 12-11-015			Date of initial issue	9 February 2011	
Test report number of revised/replaced issue:	---			Date of revised/replaced issue	---	
Test report revision/ replacement history:	Test report no.	Rev. no.	Date	Page	Item	Description of change/reason
	---	---	---	---	---	---
Test standard(s)/ Test specifications:	FCC 47 CFR, Sections: 2.1046 - RF Power Output, 2.1047 - Modulation Characteristics, 2.1049 - Occupied Bandwidth, 2.1051 - Spurious Emissions at Antenna Terminal, 2.1055 - Frequency Stability, 2.1053 - Field Strength of Spurious Radiation, 80.217 - Suppression of Interference Aboard Ships. (Date of issue: 1 October 2009)					
Customer:	Furuno Electric Co., Ltd. 9-52 Ashihara-Cho, Nishinomiya-City, 662-8580 Japan					
Manufacturer:	Furuno Electric Co., Ltd. 9-52 Ashihara-Cho, Nishinomiya-City, 662-8580 Japan					
Trade name:	FURUNO					
Model:	Transceiver for Marine Radar					
Type:	RTR-079A					
Product function and intended use:	For Marine Safety navigation					
Number of samples tested:	One					
Serial number:	R136-5807					
Power rating:	24 VDC, 9.7 A or 100 - 115, 3.0 - 3.4 A/220 - 230 VAC, 1.8/1.9A 50/60 Hz (for Processer Unit RPU-013) (The EUT was powered through the Processor unit, not directly from AC/DC mains.)					
Product status:	Pre-production model					
Modifications made to samples during testing:	None.					
Date of receipt of samples:	12 July 2010					
Test period:	13 July 2010 to 6 January 2011					
Place of test:	Furuno Labotech International Co., Ltd. - Nishinomiya Lab. 9-52 Ashihara-Cho, Nishinomiya City, Hyogo Prefecture, 662-8580 Japan - Nishinomiya-Hama Lab. 2-20 Nishinomiya-Hama, Nishinomiya City, Hyogo Prefecture, 662-0934 Japan Anechoic Chamber used for the test has been registered by FCC. <b>(File number: 90607)</b>					
Test results/ Compliance:	Passed. The test results of this report relate only to the samples tested.					
Tested by:	Katsumi Imamura					
Written by:	Akiko Inoue					
Verified by:	Yoshihiro Ishii					
Approved by:	Date: 9 February 2011 Name: Yoshihiro Ishii Title: Manager, Technical Section, Furuno Labotech International Co., Ltd. Signature: <div style="text-align: center; margin-top: 20px;">  </div>					

## Testing Laboratory Status

Furuno Labotech International Co., Ltd. (hereafter called FLI) has been holding the following status after having been assessed according to the provisions of ISO/IEC 17025 and/or the relevant rules:

(1) Telefication Listed Testing Laboratory:

- listed by Telefication B. V., Edisonstraat 12a, 6902 PK Zevenaar, The Netherlands
- Laboratory assignment number: L116
- Date of initial certification: 26 July 1999 (\*)
- for testing the following product categories/ test standards:
  - EN 60945, Maritime navigation and radiocommunication equipment and systems - General requirements.
  - IEC 61162-1/-2, Maritime navigation and radiocommunication equipment and systems - Digital interfaces - Part 1: Single talker and multiple listeners / Part 2: Single talker and multiple listeners, high speed transmission.

(2) BSH Recognized Testing Laboratory:

- recognized by Bundesamt für Seeschifffahrt und Hydrographie, Bernhad-Nocht-Str. 78, 20359 Hamburg, Federal Republic of Germany
- Recognition certificate number: BSH4613/06201/0835/08
- Date of initial certification: 4 April 2003 (\*)
- for testing in the fields of:
  - “Marine navigational and radiocommunication equipment and systems”
  - EMC and environmental tests according to:
    - IEC 60945: 2002, DIN EN 60945: 2003
  - Radar
    - IEC 60936-1: 1999, DIN EN 60936-1: 2000
    - IEC 60936-2: 1998, DIN EN 60936-2: 1999
  - Shipborne navigational displays
    - IEC 62288: 2008

(3) TÜV Appointed EMC Test Laboratory:

- appointed by TÜV Rheinland Japan Ltd., 19-5 Shin Yokohama 3-chome, Kohoku-ku, Yokohama 222-0033 Japan
- Laboratory assignment number: UA 50046428
- Date of initial certification: 21 December 1998 (\*)
- for carrying out the tests of:
  - EN 55022, CISPR 22, EN 61000-3-2/-3, EN/IEC 61000-4-2/-3/-4/-5/-6/-8/-11, EN/IEC 61000-6-1/-2, EN/IEC 61000-6-3/-4, EN/IEC 60945, EN/IEC 61326-1, EN/IEC 61326-2-6, EN/IEC 60601-1-2, JIS T 0601-1-2, JIS C 1806-1, EN 55011, CISPR 11.

(4) RMRS Recognized Testing Laboratory:

- recognized by Russian Maritime Register of Shipping, 8, Dvortsovaya Nab., St. Petersburg, 191186 Russia
- Laboratory recognition number : 09.00110.011
- Date of initial certification : 27 January 2009 (\*)
- for carrying out testing in the field of :
  - 21001301 Electrical measurements and tests, 21001302 EMC tests, 21001500 Mechanical measurements and tests, 21002000 Equipment protection degree tests, and 21002100 Climatic tests for Ship’s radio and navigational equipment and IEC 60945 : 2002

Note: (\*) – The current certificates may be found in the FLI web site (<http://www.furuno-labotech.co.jp>).

**TABLE OF CONTENTS**

**Report Summary** ..... 2

**Testing Laboratory Status** ..... 3

**1 Principal Information** ..... 5

1.1 Equipment under test (EUT) ..... 5

1.2 Observation and comments ..... 8

**2 Test Results Summary** ..... 8

**3 Test Results**..... 9

3.1 RF Power Output (FCC Rule, 2.1046) ..... 9

3.2 Modulation Characteristics (FCC Rule, 2.1047)..... 9

3.3 Occupied Bandwidth (FCC Rule, 2.1049) ..... 10

3.4 Frequency Stability (FCC Rule, 2.1055)..... 10

3.5 Spurious Emissions ..... 12

    3.5.1 Spurious Emissions at Antenna Terminal (FCC Rule, 2.1051)..... 12

    3.5.2 Field Strength of Spurious Radiation (FCC Rule, 2.1053)..... 12

3.6 Suppression of Interference Aboard Ships (FCC Rule, 80.217) ..... 14

**4 Test Setup for Measurement:** ..... 16

**5 Measuring Equipment List:**..... 18

**6 Photograph of Test Setup/Arrangement**..... 20

**7 RF Envelope and Spectrum of the output pulse**..... 22

**8 Spurious Emission Plots measured at Antenna Terminal** ..... 29

**9 Field Strength Plots of Spurious Radiation**..... 30

**10 Field Strength Plots for Suppression of Interference Aboard Ships** ..... 36

# 1 Principal Information

## 1.1 Equipment under test (EUT)

### 1.1.1 General

- (a) Trade name: Furuno
- (b) Manufacturer: Furuno Electric Co., Ltd.  
Ashihara-cho 9-52, Nishinomiya-city, 662-8580 Japan
- (c) Model:

	Type	Serial Number	Note
Transceiver	RTR-079A	---	Contained in the Scanner.
Scanner	RSB-097	R136-5807	
Antenna	XN12AF XN20AF XN24AF	---	One (1) selectable.

- (d) Primary Function: Search, Navigation and Anti-collision
- (e) Frequency Range: Fixed frequency, X-band (9410 MHz)  
Type of Emission: P0N
- (f) Power Supply: 24 VDC or 100 - 115/220 - 230 VAC (for Processor unit),  
(fed through the specified external equipment, not directly from AC/DC mains)

### 1.1.2 Radar Sensor

#### 1.1.2.1 Transceiver

**Type:** RTR-079A  
(Contained in the Scanner)

#### (1) Transmitter

- (a) Assignable Frequency for Shipborne Radar:  
Between 9300 and 9500 MHz (FCC Rule, 80.375 (d)-(1))
- (b) Type of RF Generator  
Magnetron Type: MG5436  
Peak Output Power: 25 kW nominal
- (c) Magnetron Ratings  
Center frequency of Magnetron: 9410 MHz  
Tolerances:  $\pm 30$  MHz  
Pulling: 27 MHz  
Tolerance for 20°C temperature variation: -5 MHz

#### (d) Pulse Characteristics:

Pulse type	S1	S2	M1	M2	M3	L1	L2
Pulselength ( $\mu$ s)	0.07	0.15	0.30	0.50	0.70	1.2	1.2
P.R.R.(Hz)	3000	3000	1500	1000	1000	600	500

**(2) Modulator**

- (a) FET Type: 2SK1446  
Trigger Voltage: Approx. +16 VDC positive

**(3) Receiver**

- (a) Passband  
RF Stage: 100 MHz  
IF Stage:

Pulse type	S1	S2	M1	M2	M3	L1	L2
Passband (MHz)	40	40	10	10	10	3	3

- (b) Gain (overall): approximately 130 dB
- (c) Overall Noise Figure: 6 dB (typical)
- (d) Video Output Voltage: 2 V Negative
- (e) Features Provided: Sensitivity Time Controls (Anti-clutter Sea),  
Fast Time Constant (Anti-clutter Rain)
- (f) If receiver is tunable, describe method for adjusting frequency:  
by adjustment of tuning voltage of receiver local oscillator (Automatic and manual)

**1.1.2.2 Antenna and Scanner**

- (a) Antenna Rotation ON-OFF Switch: Provided.
- (b) Antenna structure: Slotted array antenna  
(installed on the Scanner)

- (c) Antenna size:

Radiator type:	XN12AF	XN20AF	XN24AF
Length (cm):	129	206	257
Length (ft):	4	6.5	8

- (d) Type of Beam: Vertical fan

- (e) Beam Width (3 dB):

Antenna type	XN12AF	XN20AF	XN24AF
Horizontal (°)	1.90	1.23	0.95
Vertical (°)	20	20	20

- (f) Polarization: Horizontal

- (g) Antenna Gain:

Antenna type	XN12AF	XN20AF	XN24AF
Gain (dB)	27.5	30.0	31.5



- (e) Approximate Weight of Complete Installation:  
                     Antenna Unit:                      42 kg (with Antenna XN24AF installed.)
- (f) Approximate space required for installation excluding scanner: not applicable.

## 1.2 Observation and comments

None.

## 2 Test Results Summary

CFR 47 Section	Item	Result	Test Engineer
2.1046	RF Power Output	Passed.	K. Imamura
2.1047	Modulation Characteristics	Passed.	K. Imamura
2.1049	Occupied Bandwidth	Passed.	K. Imamura
2.1055	Frequency Stability	Passed.	K. Imamura
	Spurious Emissions	---	---
2.1051	- Spurious Emissions at Antenna Terminal	Passed.	K. Imamura
2.1053	- Field Strength of Spurious Radiation	Passed.	K. Imamura
80.217	Suppression of Interference Aboard Ships	Passed.	K. Imamura



### 3 Test Results

#### 3.1 RF Power Output (FCC Rule, 2.1046)

**(1) Test conditions:**

For all TX (S1/S2/M1/M2/M3/L1/L2) Pulses, the transmitter output power was measured at the antenna port with Antenna replaced with the Non-reflective load.

**(2) Test setup:**

See Clause 4.

**(3) Test Results:**

Pulse type	S1	S2	M1	M2	M3	L1	L2
Magnetron Output, mean (W):	3.3	5.8	7.1	9.2	13.6	13.1	11.3
Magnetron Output, peak (kW):	13.1	13.8	15.7	17.8	18.5	18.3	18.3

Environmental conditions observed: On 15 December 2010, 21°C to 22°C, 42% to 39%RH  
Power supply voltage measured (\*):100.0 VAC to 100.0 VAC.

(\*): Power input voltages to the external equipment (Processor Unit RPU-013) measured.

#### 3.2 Modulation Characteristics (FCC Rule, 2.1047)

**(1) Test Conditions:**

The RF envelope of the magnetron output pulse was measured using an envelope detector and an oscilloscope.

Each pulse spectrum was measured using a spectrum analyzer.

**(2) Test setup:**

See Clause 4.

**(3) Limits (FCC Rule, 80.213 (g)):**

Upper limit frequency,  $f(U) = f_0 + f(AUBW)/2 - 1.5/T$

Lower limit frequency,  $f(L) = f_0 - f(AUBW)/2 + 1.5/T$

Note: Assigned frequency ( $f_0$ ): 9410 MHz

Authorized bandwidth ( $f(AUBW)$ ): 100 MHz

**(4) Test Results:**

Complied.

Pulse type	S1	S2	M1	M2	M3	L1	L2	Result
Pulselength T ( $\mu$ s) (-3 dB points)	0.082	0.136	0.294	0.498	0.712	1.192	1.192	Not applicable
Rise time $t_r$ ( $\mu$ s) (10 - 90 % amplitude)	0.010	0.010	0.010	0.014	0.018	0.018	0.018	Not applicable
Decay time $t_f$ ( $\mu$ s) (90 - 10 % amplitude)	0.089	0.138	0.196	0.192	0.126	0.128	0.128	Not applicable

Pulse type	S1	S2	M1	M2	M3	L1	L2	Result
PRR (Hz)	3079	3079	1547	1033	1033	602	517	Not applicable
Guard Band f(1.5/T) (MHz) (*)	18.3	11.0	5.1	3.0	2.1	1.3	1.3	Not applicable
f(U) (MHz)	9441.7	9449.0	9454.9	9457.0	9457.9	9458.7	9458.7	Complied
f(L) (MHz)	9378.3	9371.0	9365.1	9363.0	9362.1	9361.3	9361.3	Complied
Frequency at maximum emission (MHz)	9397.0	9397.0	9398.0	9397.0	9395.5	9396.0	9395.0	Complied

(\*): Guard Band is specified to be equal to 1.5/T MHz, where "T" is the pulselength in microseconds.  
(FCC Rule, 80.209(b))

Measured Plots: See Clause 7.

Environmental conditions observed: On 15 December 2010, 21°C to 22°C, 42% to 39%RH  
Power supply voltage measured (\*):100.0 VAC to 100.0 VAC.

(\*): Power input voltages to the external equipment (Processor Unit RPU-013) measured.

### 3.3 Occupied Bandwidth (FCC Rule, 2.1049)

#### (1) Test conditions:

For all TX (S1/S2/M1/M2/M3/L1/L2) Pulses, the transmitter occupied bandwidth was measured at the antenna port with Antenna replaced with the Non-reflective load.

#### (2) Test setup:

See Clause 4.

#### (3) Test Results:

Pulse type	S1	S2	M1	M2	M3	L1	L2
Occupied bandwidth (MHz)	60.7	57.5	51.0	33.0	13.2	10.2	9.8

Environmental conditions observed: On 15 December 2010, 21°C to 22°C, 42% to 39%RH  
Power supply voltage measured (\*):100.0 VAC to 100.0 VAC.

(\*): Power input voltages to the external equipment (Processor Unit RPU-013) measured.

### 3.4 Frequency Stability (FCC Rule, 2.1055)

#### (1) Test Conditions:

- 1) Radar Transmitter settings: All TX (S1/S2/M1/M2/M3/L1/L2) Pulses
- 2) Ambient Temperature settings: - 20°C to + 50°C (10°C interval)
- 3) Power Supply Voltage settings: 85 /115 % of nominal voltage (85 VAC/133 VAC)

#### (2) Test setup:

See Clause 4.

**(3) Frequency Tolerance Limits (FCC Rule, 80.213 (g)):**

Pulse type	S1	S2	M1	M2	M3	L1	L2
f(U) (MHz)	9441.7	9449.0	9454.9	9457.0	9457.9	9458.7	9458.7
f(L) (MHz)	9378.3	9371.0	9365.1	9363.0	9362.1	9361.3	9361.3

See Clause 3.2 for details.

**(4) Test Results:**

Complied.

Power Supply Voltage setting (\*): 85 VAC

Pulse type		S1	S2	M1	M2	M3	L1	L2	Result
Frequency at maximum emission (MHz)	-30°C	9408.0	9407.0	9407.5	9407.0	9405.0	9404.5	9405.0	Complied
	-20°C	9405.8	9405.0	9405.6	9405.0	9403.1	9402.8	9403.0	Complied
	-10°C	9403.6	9403.0	9403.7	9403.0	9401.2	9401.1	9401.0	Complied
	0°C	9401.4	9401.0	9401.8	9401.0	9399.3	9399.4	9399.0	Complied
	+10°C	9399.2	9399.0	9399.9	9399.0	9397.4	9397.7	9397.0	Complied
	+20°C	9397.0	9397.0	9398.0	9397.0	9395.5	9396.0	9395.0	Complied
	+30°C	9395.3	9395.3	9395.3	9394.3	9392.7	9393.0	9392.3	Complied
	+40°C	9393.7	9393.7	9392.7	9391.7	9389.8	9390.0	9389.7	Complied
	+50°C	9392.0	9392.0	9390.0	9389.0	9387.0	9387.0	9387.0	Complied

Power Supply Voltage setting (\*): 133 VAC

Pulse type		S1	S2	M1	M2	M3	L1	L2	Result
Frequency at maximum emission (MHz)	-30°C	9408.0	9407.0	9407.5	9407.0	9405.0	9404.5	9405.0	Complied
	-20°C	9405.8	9405.0	9405.6	9405.0	9403.1	9402.8	9403.0	Complied
	-10°C	9403.6	9403.0	9403.7	9403.0	9401.2	9401.1	9401.0	Complied
	0°C	9401.4	9401.0	9401.8	9401.0	9399.3	9399.4	9399.0	Complied
	+10°C	9399.2	9399.0	9399.9	9399.0	9397.4	9397.7	9397.0	Complied
	+20°C	9397.0	9397.0	9398.0	9397.0	9395.5	9396.0	9395.0	Complied
	+30°C	9395.3	9395.3	9395.3	9394.3	9392.7	9393.0	9392.3	Complied
	+40°C	9393.7	9393.7	9392.7	9391.7	9389.8	9390.0	9389.7	Complied
	+50°C	9392.0	9392.0	9390.0	9389.0	9387.0	9387.0	9387.0	Complied

Environmental conditions observed: On 13 July 2010, 24°C to 24°C, 53% to 53%RH

On 14 July 2010, 25°C to 25°C, 61% to 61%RH

On 15 July 2010, 24°C to 24°C, 60% to 60%RH

(\*): Power input voltages to the external equipment (Processor Unit RPU-013) measured.

**3.5 Spurious Emissions**

**3.5.1 Spurious Emissions at Antenna Terminal (FCC Rule, 2.1051)**

**(1) Test Conditions:**

For all TX (S1/S2/M1/M2/M3/L1/L2) Pulses, the transmitter output power will be measured at the antenna port with Antenna replaced with the Non-reflective load.

**(2) Test setup:**

See Clause 4.

**(3) Emission Limits (FCC Rule, 80.211 (f)):**

Frequency removed from the assigned frequency	Emission attenuation (mean power, dB)
50 - 100 % (of the authorized bandwidth)	At least 25
100 - 250 % (of the authorized bandwidth)	At least 35
more than 250 % (*) (of the authorized bandwidth)	At least $43 + 10 \log_{10}$ (mean power in watts)

Note: (1) Authorized bandwidth = 100 MHz

(\*) - for the relevant frequency bands, tests were performed according to FCC Rule, 2.1053. See Clause 3.5.2.

**(4) Test Results:**

Complied.

From the results of the pre-tests, the EUT emission level was found to be the maximum with S1 pulse. Consequently, the test was performed only with S1 pulse.

Spectrum Plots: See Clause 8.

Environmental conditions observed: On 16 December 2010, 20°C to 20°C, 40% to 40 %RH  
Power supply voltage measured (\*):100.0 VAC to 100.0 VAC.

(\*) : Power input voltages to the external equipment (Processor Unit RPU-013) measured.

**3.5.2 Field Strength of Spurious Radiation (FCC Rule, 2.1053)**

**(1) Test Conditions:**

For all TX (S1/S2/M1/M2/M3/L1/L2) Pulses, the Radiated Emission test was performed.

(a) For the test frequency range of 9 kHz to 2000 MHz, the Antenna for Transceiver was replaced with the rotating non-reflective load. Spurious emissions for 9 kHz to 2000 MHz are not found at the antenna terminal due to its structure (Waveguide tube). The EUT cabinet radiation was measured with the EUT rotated 360°.

(b) For 2 GHz to 40 GHz, the Antenna was set to the Transceiver with the stop mode.

**(2) Test Site:** FLI Nishinomiya-Hama Laboratory, Semi-Anechoic Chamber  
(FCC file number: 90607)

**(3) Distance between the radar set and measuring antenna:** 3 m

**(4) Test setup:**

For the test frequency range of 2 GHz to 40 GHz, the GRP (Ground reference plane, metal floor) between the EUT and the measuring (receiving) antenna was lined with the Radio Absorbers (2.4 m × 3.0 m × 0.5 m) to reduce the influences of the reflections of the RF waves from the floor.

**Measuring (Receiving) Antenna height and polarization:**

- (a1) 1.5 m for the test frequency range of 9 kHz to 30 MHz,
- (a2) 1 m to 4 m for the test frequency range of 30 MHz to 2000 MHz,
- (b) 2.2 m that was same as those for the EUT for the test frequency range of 2 GHz to 40 GHz.
- (c) Antenna polarization: vertical and horizontal.

**EUT height:**

- (a) 0.8 m for the test frequency range of 9 kHz to 2000 MHz,
- (b) 2.2 m for the test frequency range of 2 GHz to 40 GHz (To reduce the influences of the reflections from GRP).

See Clauses 4 and 6.

**(5) Field Strength Limits (FCC Rule, 80.211 (f)):**

Frequency removed from the assigned frequency	Frequency (MHz) (for X-band)	Emission attenuation (mean power, dB)
50 - 100 % (*) (of the authorized bandwidth)	9,310 - 9,360	At least 25
	9,460 - 9,510	
100 - 250 % (*)	9,160 - 9,310	At least 35
	9,510 - 9,660	
more than 250 %	0.009 - 9,160	At least 43 + 10 log <sub>10</sub> (mean power in watts)
	9,660 - 40,000	

Note: (1) Assigned frequency (center frequency) = 9410 MHz

(2) Authorized bandwidth = 100 MHz

(\*) - for the relevant frequency bands, tests were performed according to FCC Rule, 2.1051. See Clause 3.5.1.

**(6) Test Results:**

Complied.

From the results of the pre-tests, the spurious emission level was found to be the maximum with L1 pulse. Consequently, the test was performed only with L1 pulse.

$$\begin{aligned}
 [\text{Limit}] &= 43 + 10 \log_{10} (\text{mean power in watts}) \\
 &= 43 + 10 \log_{10} (13.1) \\
 &= 54 \text{ dB}
 \end{aligned}$$

where, [ mean power in watts ] = 13.1 W for L1 pulse. See 3.1.

For this time, Limit of 60 dB was applied for the test.

The electric field strength of the maximum power radiation was 179.3 dB $\mu$ V/m with L1 pulse. Consequently, the allowable emission limit was set to 119.3 dB $\mu$ V/m (= 179.3 dB $\mu$ V/m - 60 dB).

As a result, the minimum emission attenuation was found to be more than 60 dB.

Spectrum plots: See Clause 9.

Spurious Emission Frequency and Electric Field Strength that were prominent were listed in the following table.

Frequency (GHz)	Antenna Polarization	Pulse type	Electric Field Strength measured (dB $\mu$ V/m)	Limit (dB $\mu$ V/m)	Margin (dB)
18.808	Horizontal	L1	95.93	119.3	23.37
28.190	Vertical	L1	98.13	119.3	21.17

Environmental conditions observed: On 28 December 2010, 21°C to 21°C, 49% to 49%RH  
Power supply voltage measured (\*): 100.0 VAC to 100.0 VAC.  
(\*): Power input voltages to the external equipment (Processor Unit RPU-013) measured.

**3.6 Suppression of Interference Aboard Ships (FCC Rule, 80.217)**

**(1) Test Conditions/Test Setup:** Same as those for Clause 3.5.2 (2) to (5) except for the EUT operating mode.

**(2) Test frequency range:** 9 kHz to 40 GHz

(a) for delivered power to artificial antenna,

Frequency	Power to artificial antenna	Resolution bandwidth of Spectrum analyzer
	( $\mu$ W)	
9 kHz - 150 kHz	400	1 kHz
150 kHz - 30 MHz		10 kHz
30 MHz - 100 MHz	4,000	100 kHz
100 MHz to 300 MHz	40,000	
300 MHz - 1 GHz	400,000	
1 GHz - 40 GHz		1 MHz

**(4) Test Results:**

Complied.

Spurious emission levels measured for the specified test frequency range were found below the limits. Spurious Emission Frequency and Electric Field Strength that were prominent are listed in the following table.

Frequency (GHz)	Power to artificial antenna measured		Limits		Margin (dB)
	( $\mu$ W)	(dBm)	( $\mu$ W)	(dBm)	
9.535	0.003	-54.70	400000	+26.0	80.70

Tests were performed with the EUT Standby mode (= receive only mode).

Environmental conditions observed: On 22 December 2010, 23°C to 23°C, 59% to 59%RH  
Power supply voltage measured (\*):100.0 VAC to 100.0 VAC.  
(\*): Power input voltages to the external equipment (Processor Unit RPU-013) measured.

Spectrum plots: See Clause 10.

## 4 Test Setup for Measurement:

### (1) Test Setup for Clauses 3.1, 3.2, 3.3, 3.4, and 3.5.1.

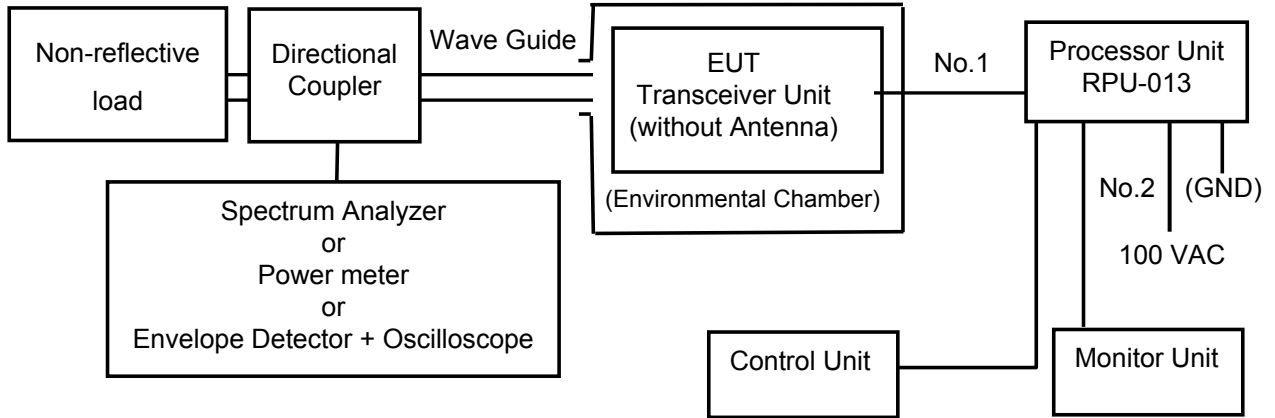

### (2) Test Setup for Clause 3.5.2

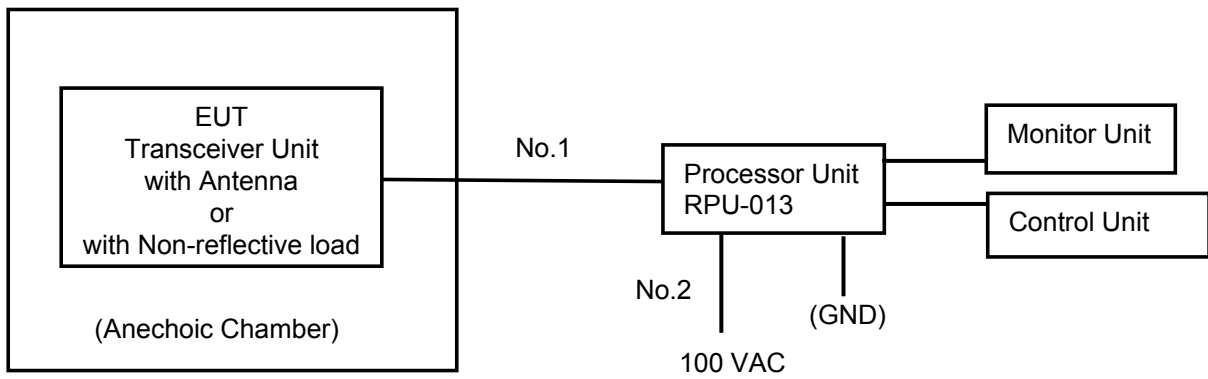



**(3) Test Setup for Clause 3.6.**

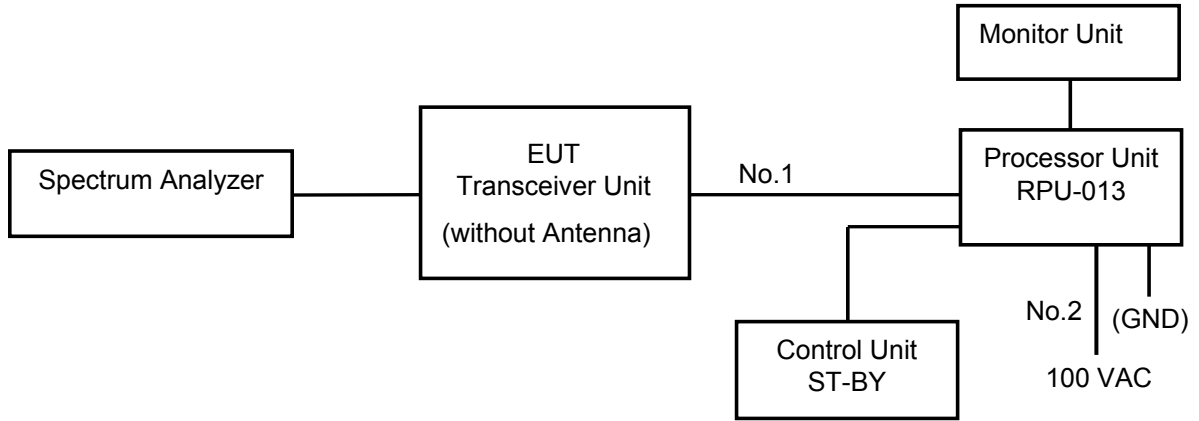

Cable designations:

No.	Name	Length (m)
1	RW-9600	20
2	DPYC-2.5	5

## 5 Measuring Equipment List:

Measuring/Test instruments have been appropriately calibrated/maintained according to the FLI programs/procedures and ISO/IEC 17025. Measuring/Test instruments used for the tests are listed below.

### (1) For 3.1 Transmitter Output Power:

C/N	Instrument	Type	S/N	Manufacturer
HT552	Power meter	E4481B	GB43315050	Agilent
HT325	Power Sensor	8481A	2702A70235	Agilent
HT656	Crystal Detector	432B	MY42243767	Agilent
8411096	Directional Coupler (X-band)	5D364S	R05762	Shimada
8411057	Dummy Load (X-band)	4D376	---	Shimada
8408087	Frequency Counter	TR5824A	41940036	Advantest
0404008	Attenuator	8494B	MY42141964	Agilent
0404008	Attenuator	8495B	MY42140929	Agilent
HT168	Oscilloscope	TDS680B	B030202	Tektronix

### (2) For 3.2 Modulation Characteristics:

C/N	Instrument	Type	S/N	Manufacturer
HT552	Power meter	E4481B	GB43315050	Agilent
HT325	Power Sensor	8481A	2702A70235	Agilent
HT656	Crystal Detector	432B	MY42243767	Agilent
8411096	Directional Coupler (X-band)	5D364S	R05762	Shimada
8411057	Dummy Load (X-band)	4D376	---	Shimada
8408087	Frequency Counter	TR5824A	41940036	Advantest
0404008	Attenuator	8494B	MY42141964	Agilent
0404008	Attenuator	8495B	MY42140929	Agilent
HT168	Oscilloscope	TDS680B	B030202	Tektronix

### (3) For 3.3 Occupied Bandwidth and for 3.5.1 Spurious Emissions at Antenna Terminal:

C/N	Instrument	Type	S/N	Manufacturer
8411096	Directional Coupler (X-band)	5D364S	R05762	Shimada
8411057	Dummy Load (X-band)	4D376	---	Shimada
HT676	Spectrum Analyzer	8564EC	4103A00440	Agilent
0404008	Attenuator	8494B	MY42141964	Agilent
0404008	Attenuator	8495B	MY42140929	Agilent
KB-011	Coaxial cable	SUCOFLEX 106 - 2m	12226/6	SUHNER
KB-137	3.5 mm cable	MWX221-2m	0804S167	Junkosha

### (4) For 3.4 Frequency Stability:

C/N	Instrument	Type	S/N	Manufacturer
HT370	Climatic chamber (L)	TBE-3HW5GE2F	3013000995	Tabai Espec
HT128	Temperature recorder (L)	437006/R1182	4370TB580	Yokogawa
8411096	Directional Coupler	5D364S	R05762	Shimada
8411057	Dummy Load	4D376	R05763	Shimada
----	Waveguide (for X-band)	WRJ-10 (l = 60 cm)	----	Furuno

C/N	Instrument	Type	S/N	Manufacturer
HT676	Spectrum Analyzer	8564EC	4103A00440	Agilent
HT654	Attenuator	8494B	MY42148134	Agilent
HT655	Attenuator	8495B	MY42144403	Agilent
KB-011	Coaxial cable	SUCOFLEX 100 - 2m	12226/6	SUHNER
KB-137	Coaxial cable	MWX221 - 2m	0804S167	Junkosha
HT432	DC power supply	PAN55-20	AK003307	Kikusui

**(5) For 3.5.2 Field Strength of Spurious Radiation:**

C/N	Instrument	Type	S/N	Manufacturer
HT463	Spectrum analyzer (9 kHz to 3 GHz)	R3132	110401654	Advantest
HT565	Loop antenna (0.15 - 30 MHz)	HFH2-Z2	100093	Rohde & Schwarz
HT459	Biconical antenna (30 MHz to 300 MHz)	VBA6106A	1296	Schaffner
HT331	Log periodic antenna (300 MHz to 1000 MHz)	UHALP9107	8411059	Schwarzbeck
HT467	Double-ridged waveguide horn antenna (1 GHz to 18 GHz)	3115	6520	EMCO
HT518	Pre-amplifier (30 MHz to 2 GHz)	87405A	3207A01643	Agilent
HT365	Semi-anechoic Chamber	3mSAC	D-002	Riken
512043	Spectrum Analyzer	FSU46	200015	Rohde & Schwarz
740060501	Horn antenna (18 GHz to 26.5 GHz)	42-442-6	E414109-01	A.H. Systems
0511041	Low-noise amplifier	JSWV4-18002600-30-8P	1058348	MITEQ
----	DC power supply for Low-noise amplifier	EX-375L2	405650060347	Takasago
740060502	Horn antenna (26.5 GHz to 40 GHz)	28-442-6	E414209-01	A.H. Systems
----	Notch Filter (X-band)	CBR-X7-3A	R9865001	Shimada
-----	Coaxial cable	SUCOFLEX 106 - 2m	-----	SUHNER
-----	Coaxial cable	SUCOFLEX 104 - 2m	-----	SUHNER
-----	Coaxial cable	SUCOFLEX 104 - 5m	250497	SUHNER
-----	Coaxial cable	SUCOFLEX 102 - 5m	265055	SUHNER

**(6) For 3.6 Spurious Emission Limits for Receivers:**

C/N	Instrument	Type	S/N	Manufacturer
HT676	Spectrum Analyzer	8564EC	4103A00440	Agilent
KB-137	3.5 mm cable	MWX221-2m	0804S167	Junkosha

## 6 Photograph of Test Setup/Arrangement

(1) For Temperature (TX frequency stability) tests,

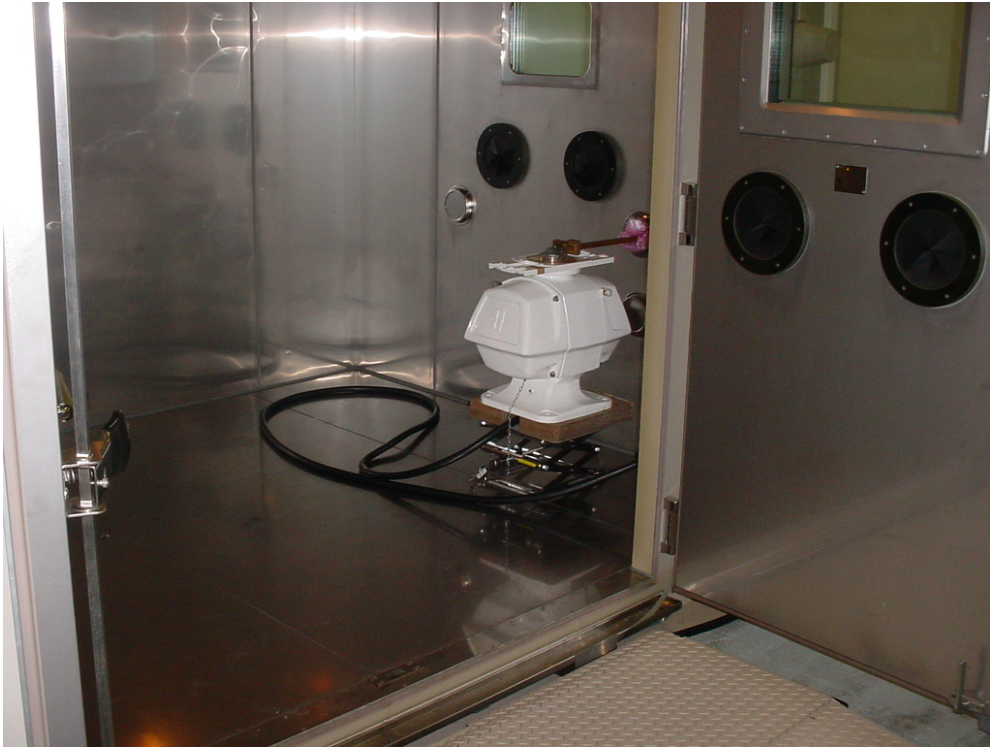

(2) For Spurious Emission measurements,



for 9 kHz to 2000 MHz



for 2 GHz to 40 GHz

### 7 RF Envelope and Spectrum of the output pulse

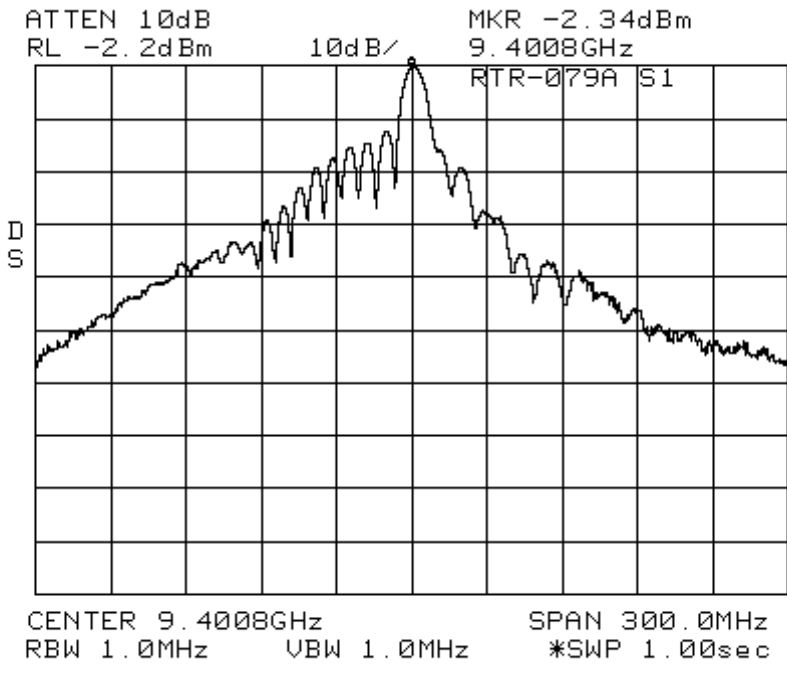
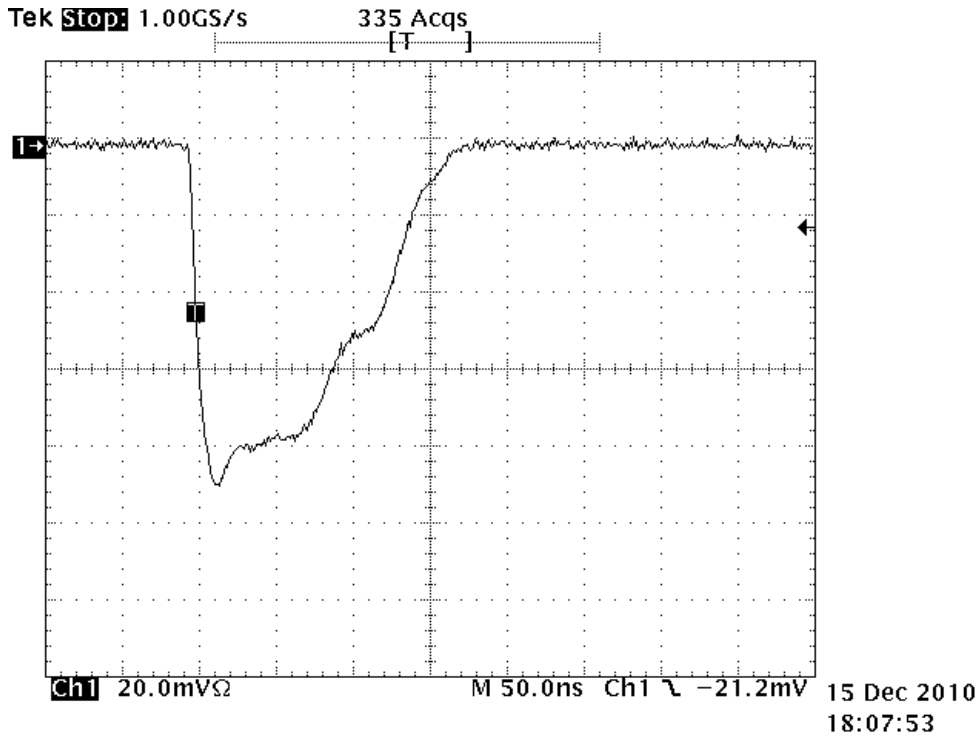

Fig. 7.1      S1 Pulse Envelope and Spectrum

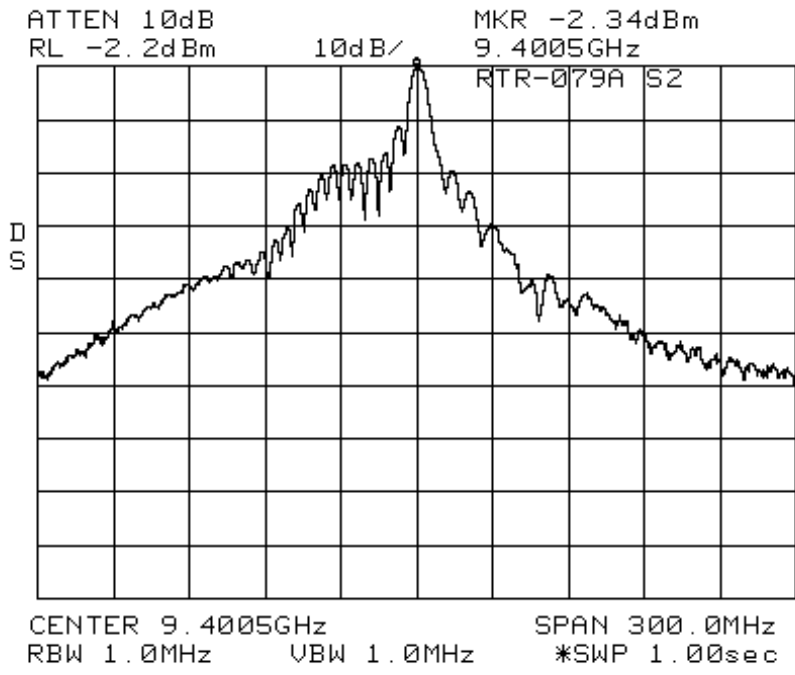
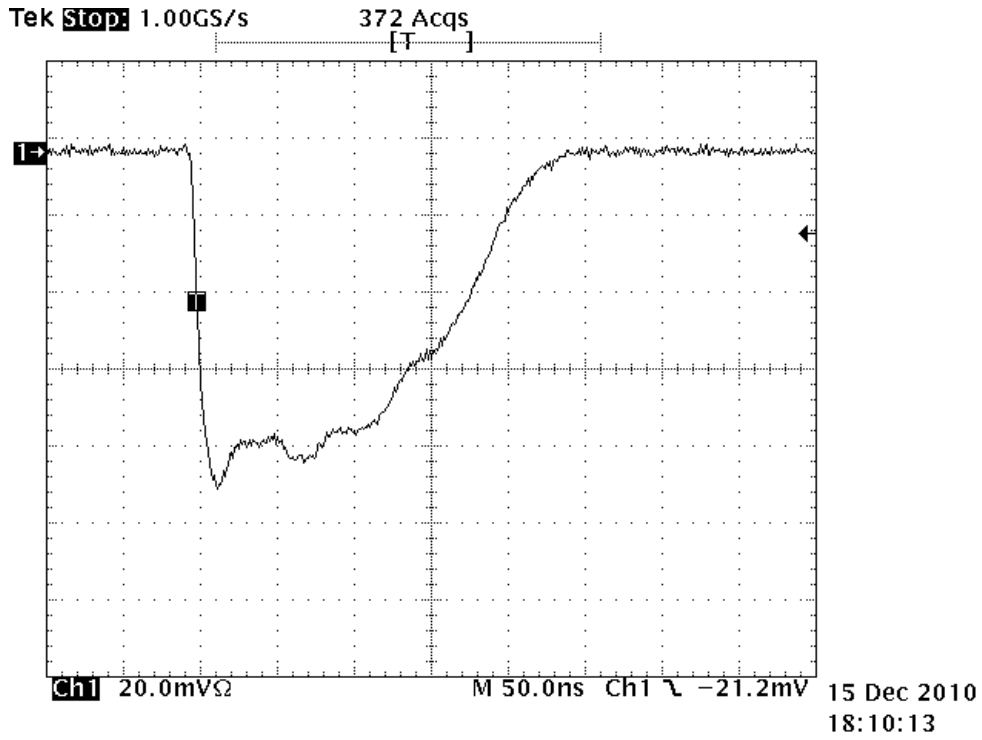

Fig. 7.2 S2 Pulse Envelope and Spectrum

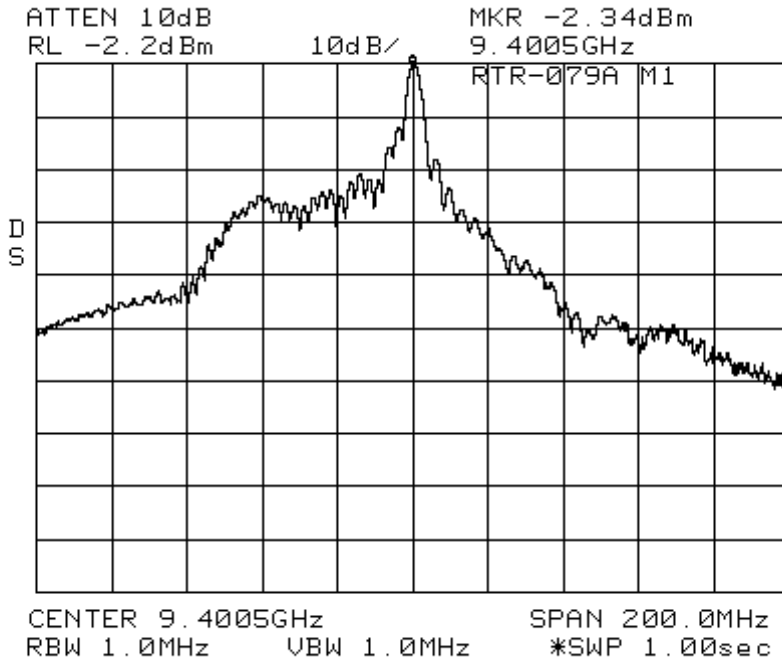
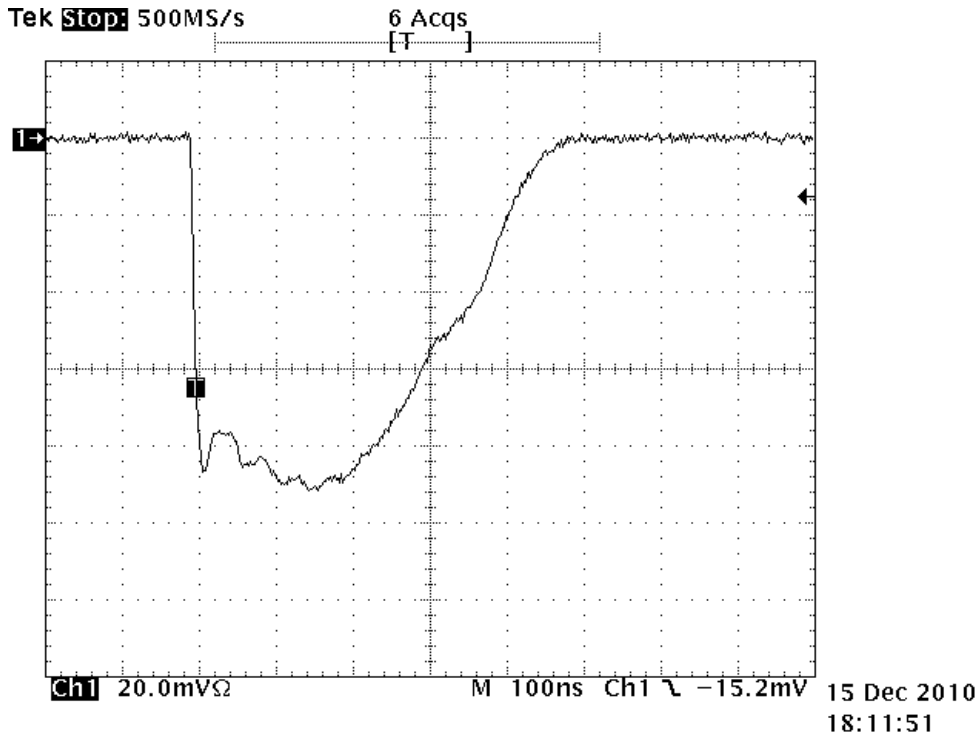

Fig. 7.3 M1 Pulse Envelope and Spectrum



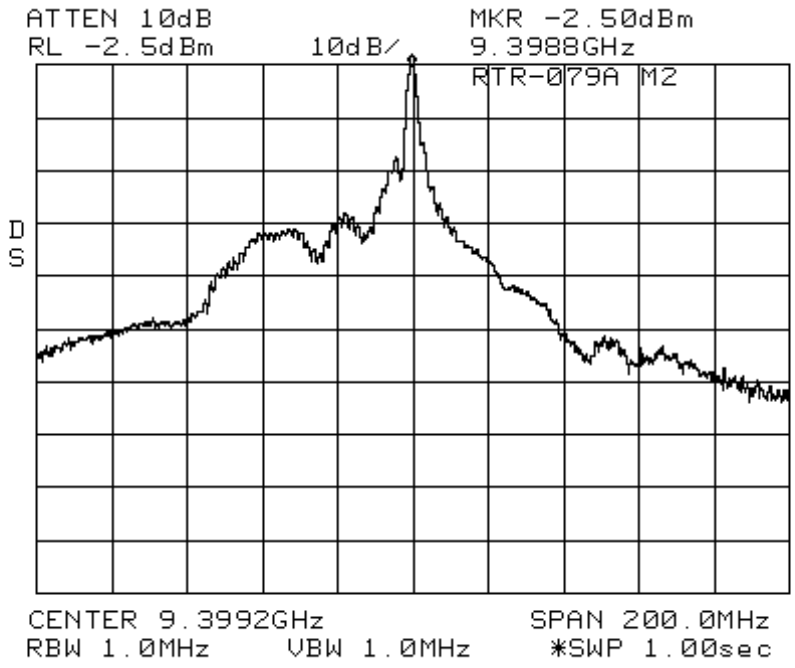
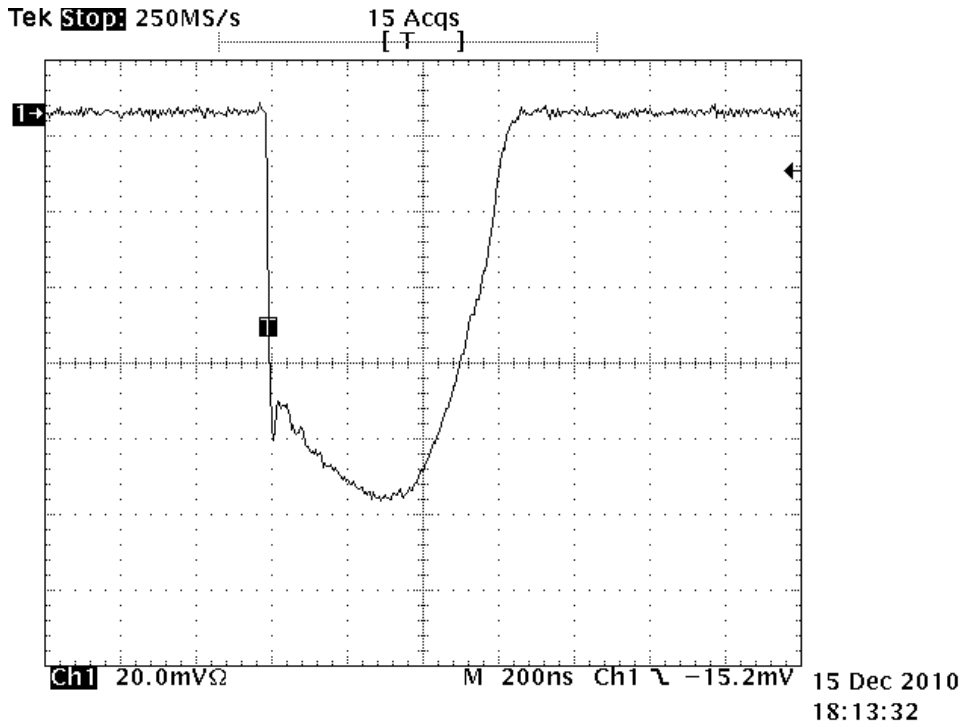

Fig. 7.4 M2 Pulse Envelope and Spectrum

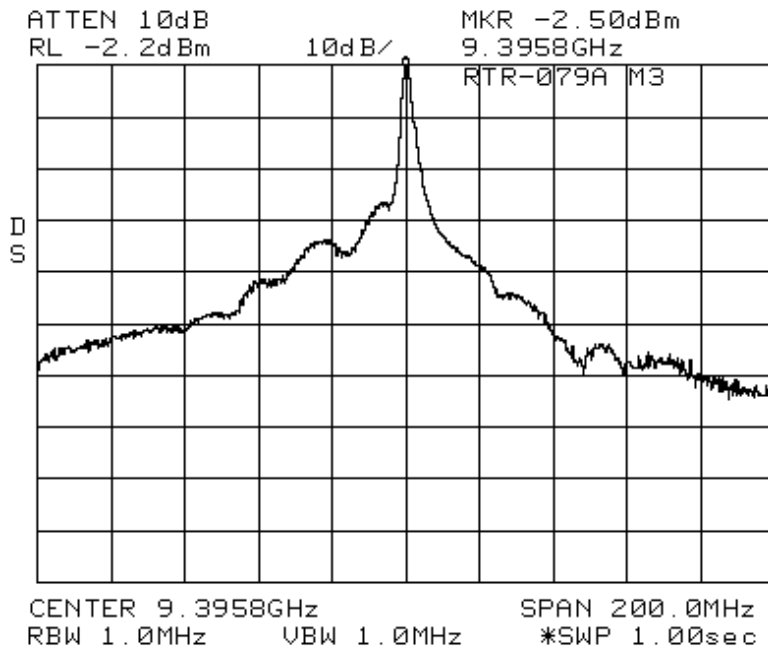
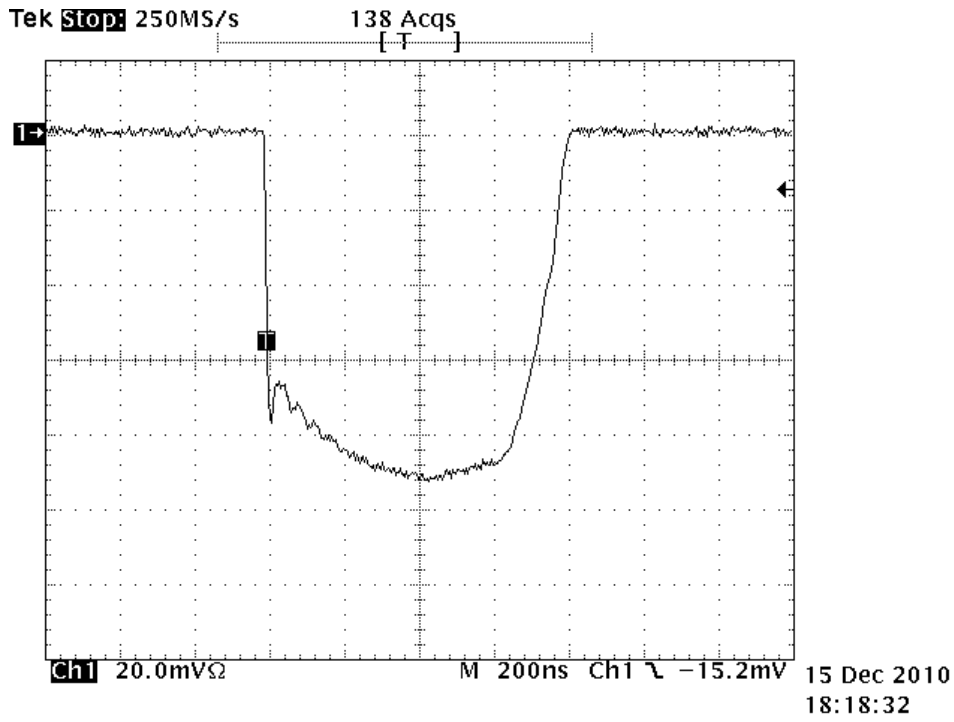

Fig. 7.5 M3 Pulse Envelope and Spectrum

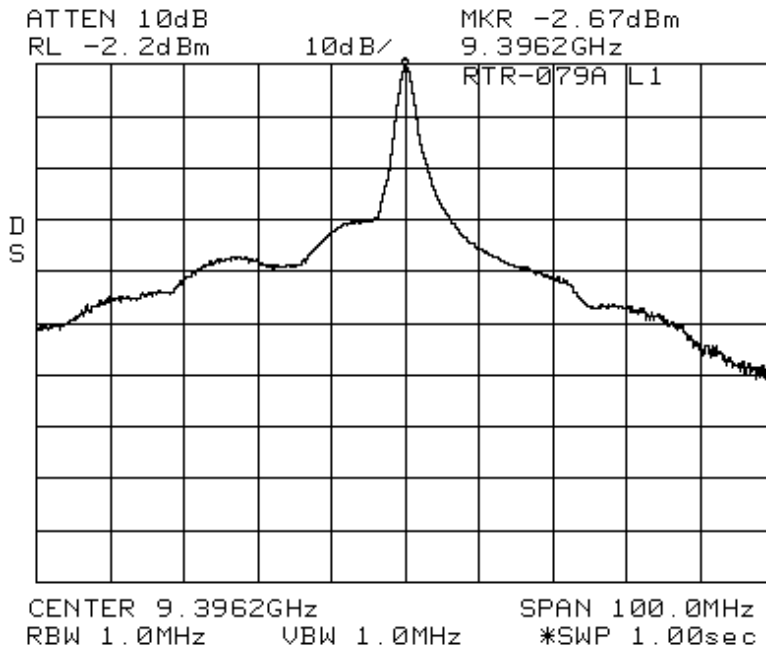
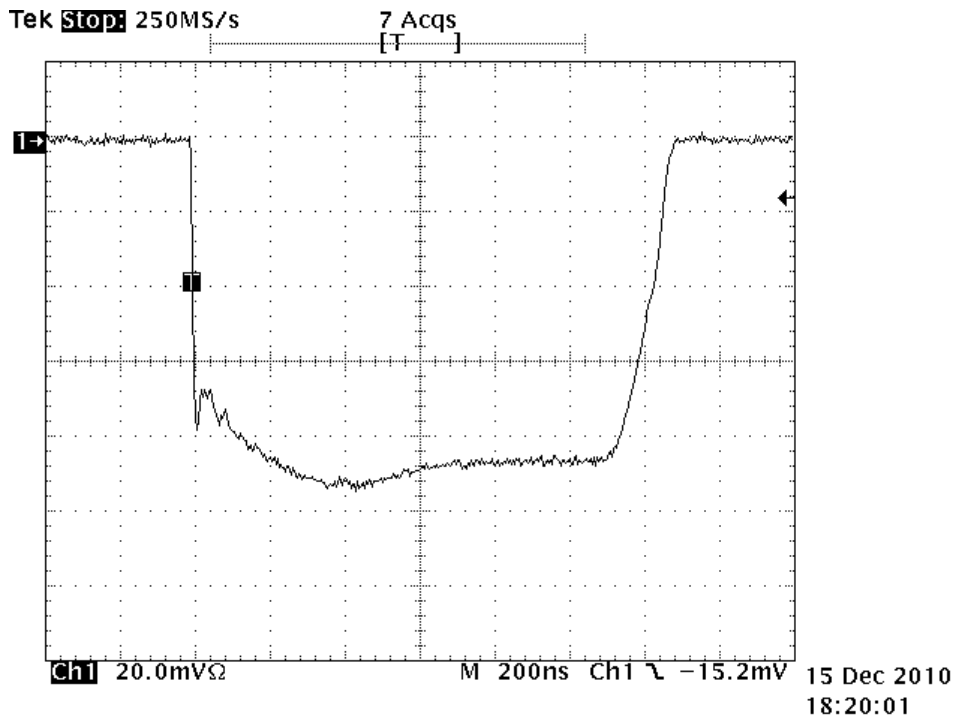

Fig. 7.6 L1 Pulse Envelope and Spectrum

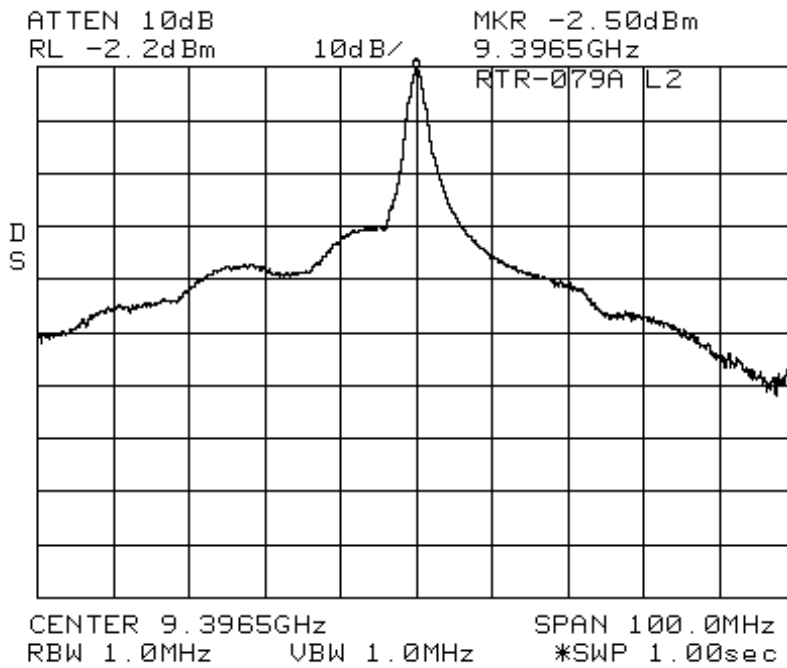
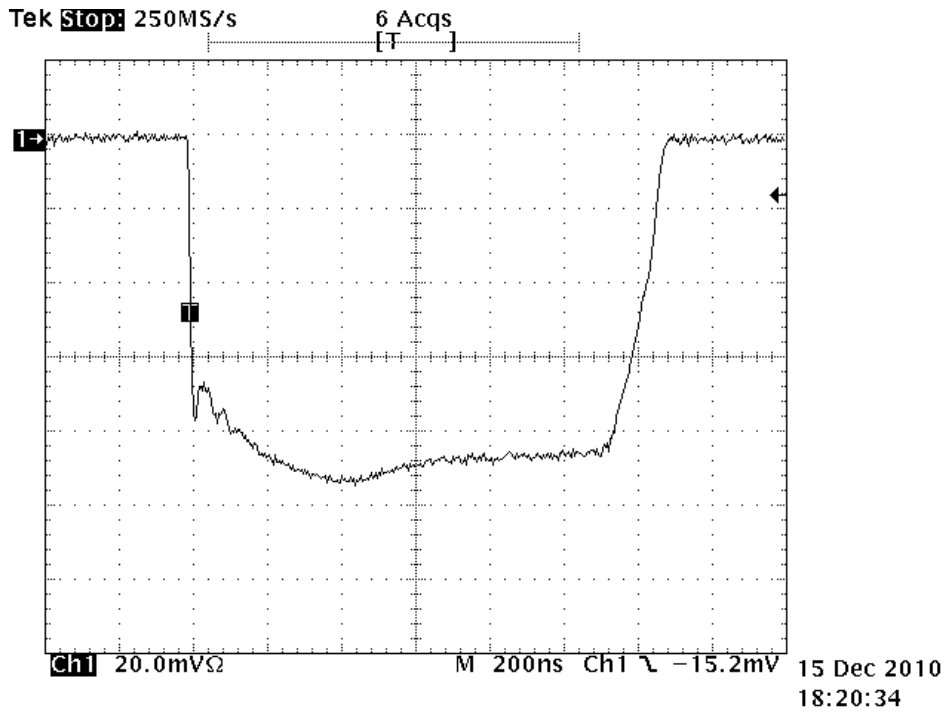
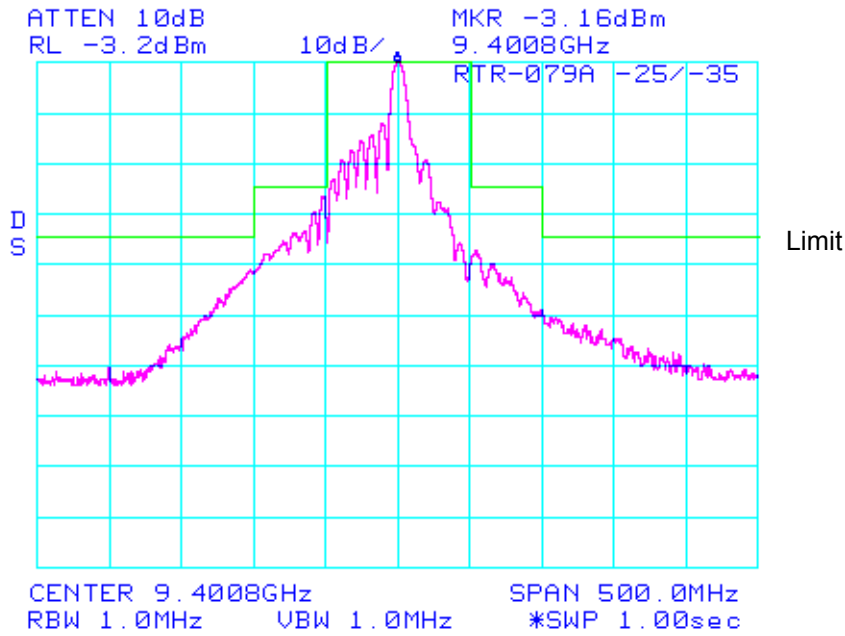

Fig. 7.7 L2 Pulse Envelope and Spectrum

## 8 Spurious Emission Plots measured at Antenna Terminal

for S1 pulse



## 9 Field Strength Plots of Spurious Radiation

### 9.1 Maximum power radiation level (for Long Pulse)

- Horizontal

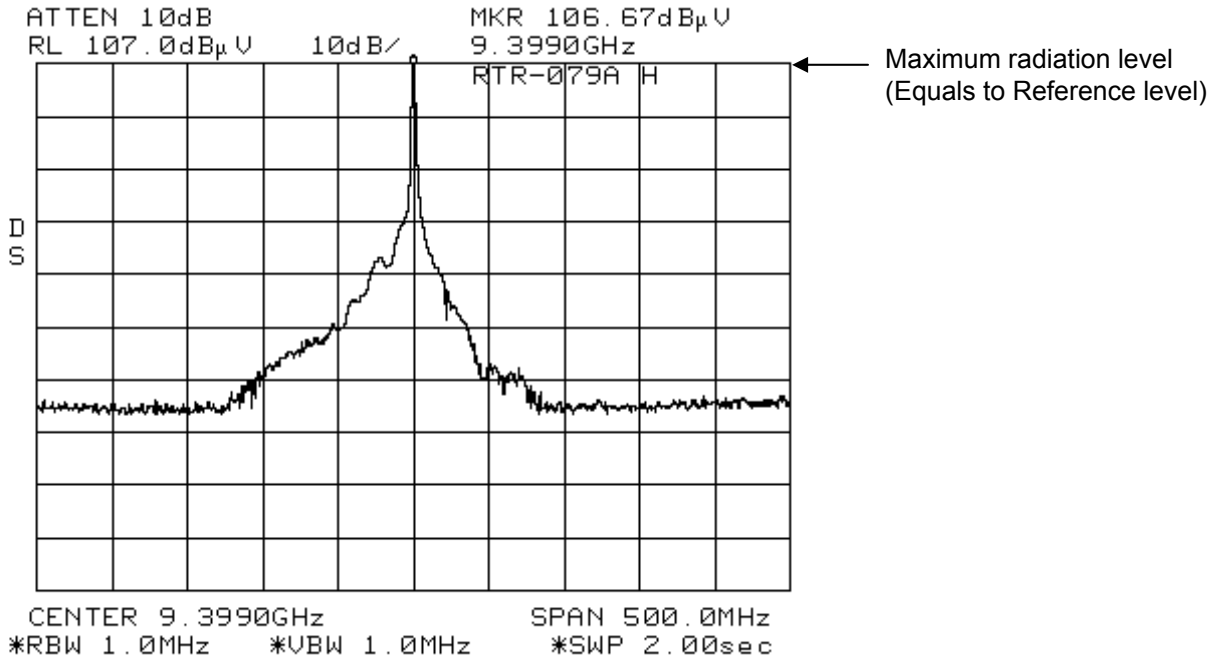

- Vertical

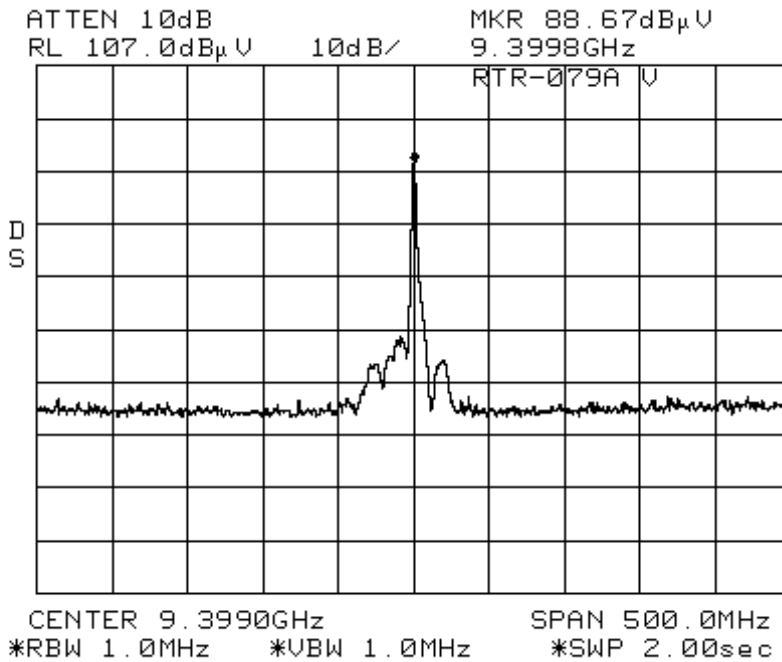

**9.2 Spurious emissions (L pulse)**

(1) for 9 kHz to 30 MHz

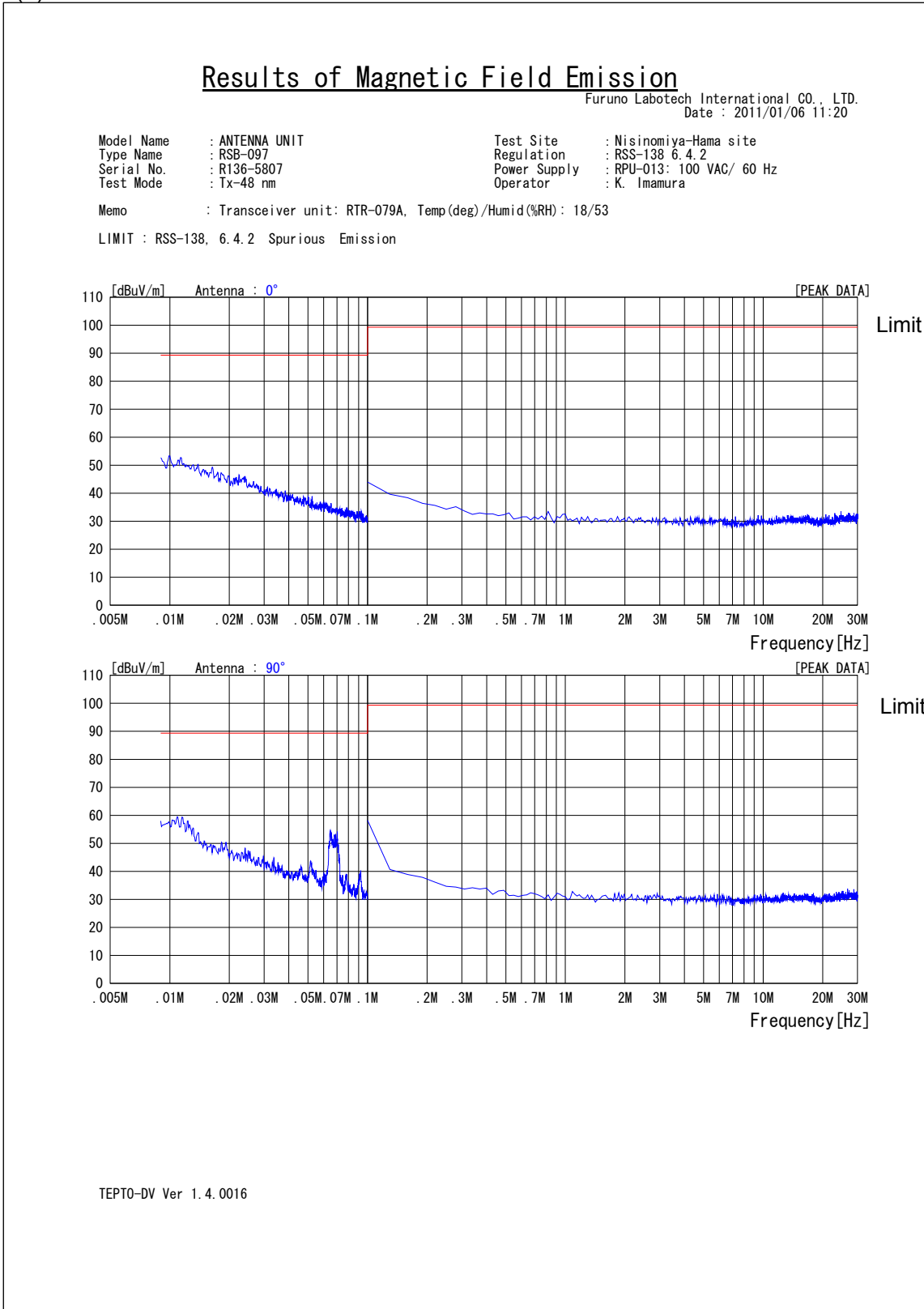

(\*) The resolution bandwidth of the spectrum analyzer for the frequency range of 9 kHz to 100 kHz was set to 1 kHz, and to 10 kHz for 100 kHz to 30 MHz, instead of 1 MHz for the frequency range of 2 GHz to 40 GHz. The applicable limit was set at 30 dB lower than that computed in Clause 9.1 for the former frequency range, and 20 dB lower for the latter frequency range.

(2) for 30 MHz to 2000 MHz

### Results of Radiated Emission

Furuno Labotech International  
Date : 2011/Jan/06 13:08

Model Name : ANTENNA UNIT  
Type Name : RSB-097  
Serial No. : R136-5807  
Test Mode : Tx-48 nm

Test Site : Nishinomiya-hama site  
Regulation : RSS-138 6.4.2  
Power Supply : RPU-013: 100 VAC/ 60 Hz  
Operator : K. Imamura

Memo : Transceiver unit: RTR-079A, Temp(deg)/Humid(%RH):18/53

LIMIT : RSS-138, 6.4.2 Spurious Emissions

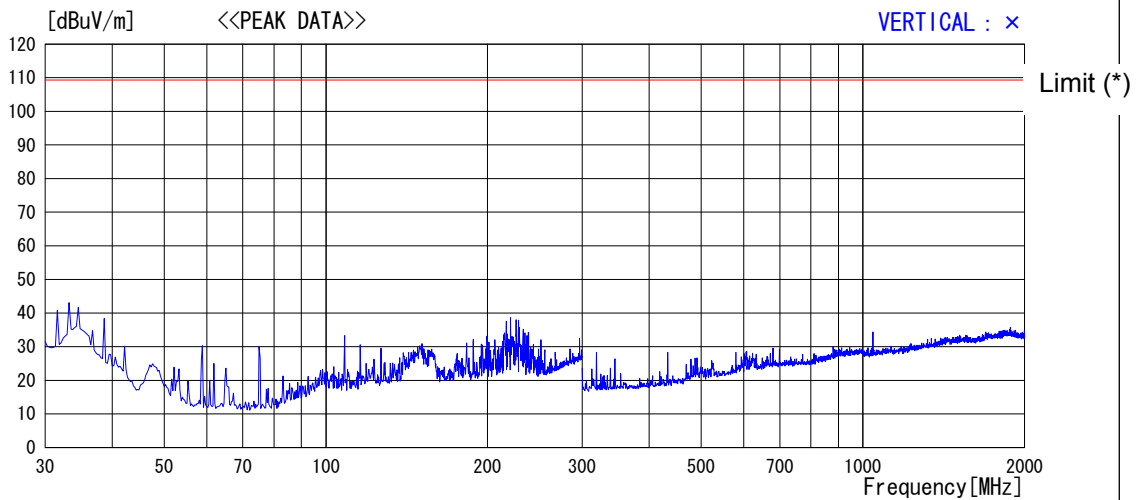
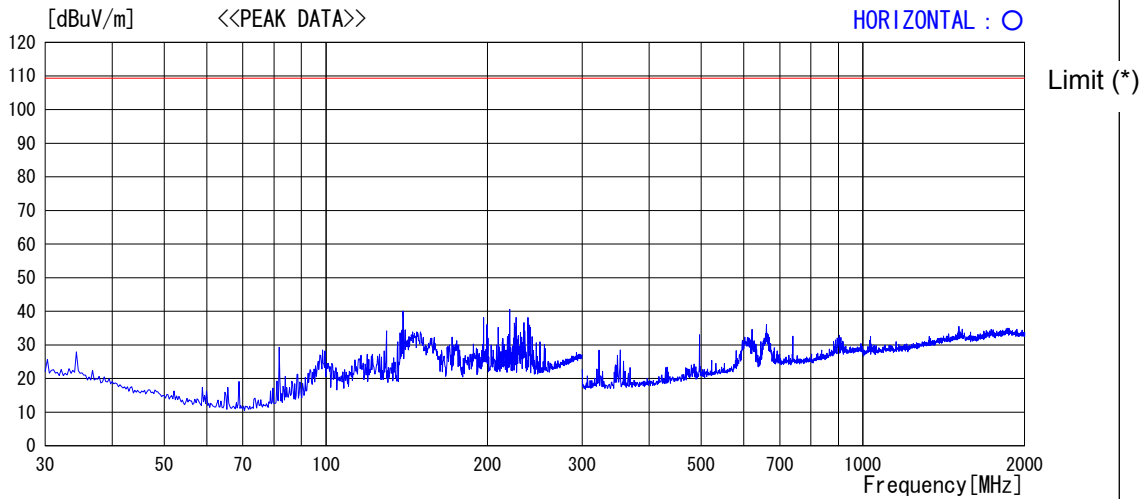

TEPT0-DV Ver 1.4.0016

(\*) The resolution bandwidth of the spectrum analyzer for the frequency range of 30 MHz to 2000 MHz was set to 100 kHz instead of 1 MHz for the frequency range of 2 GHz to 40 GHz. The applicable limit was set at 10 dB lower than that computed in Clause 9.1.



( 3 ) for 2 GHz to 18 GHz

- for Horizontal

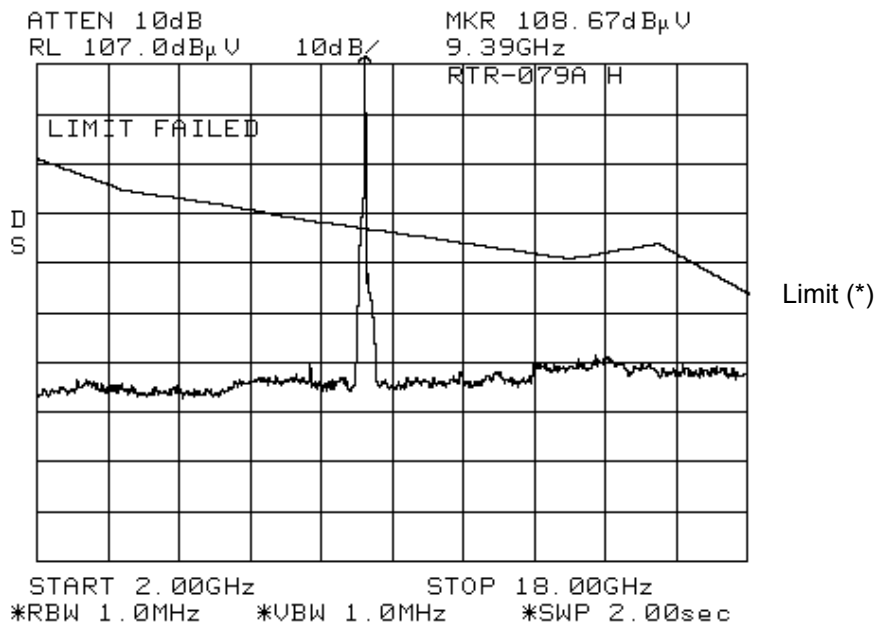

- for Vertical

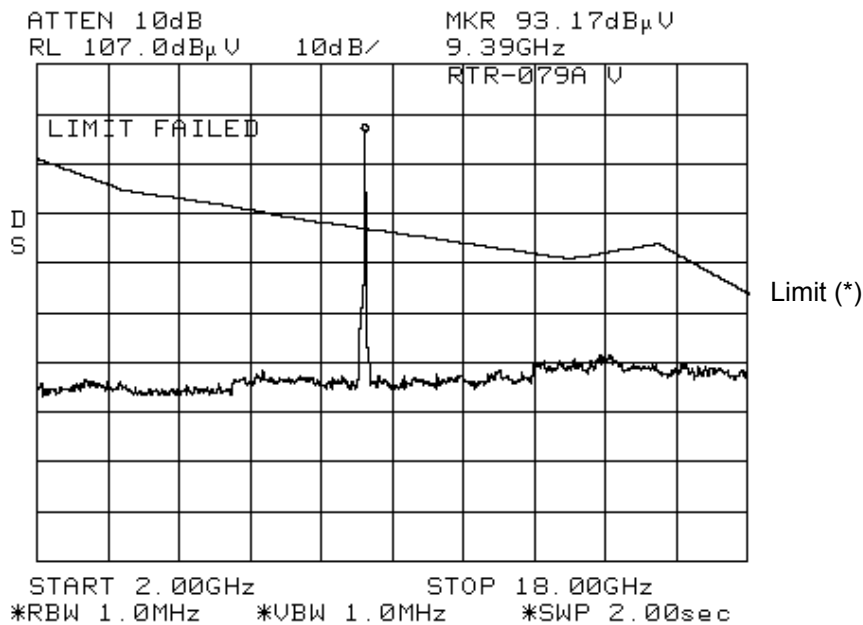

The notch filter ( Pass band: 9410 ± 150 MHz) was inserted between the measuring antenna and Spectrum Analyzer to prevent the excessive input to Spectrum Analyzer only for the test frequency range of 2 GHz to 18 GHz.

(\*) The Limit is represented by the voltage value, which was derived from the electric field strength value with Antenna factor, Cable loss and Amp. gain included.

(4) for 18 GHz to 26.5 GHz  
- for Horizontal

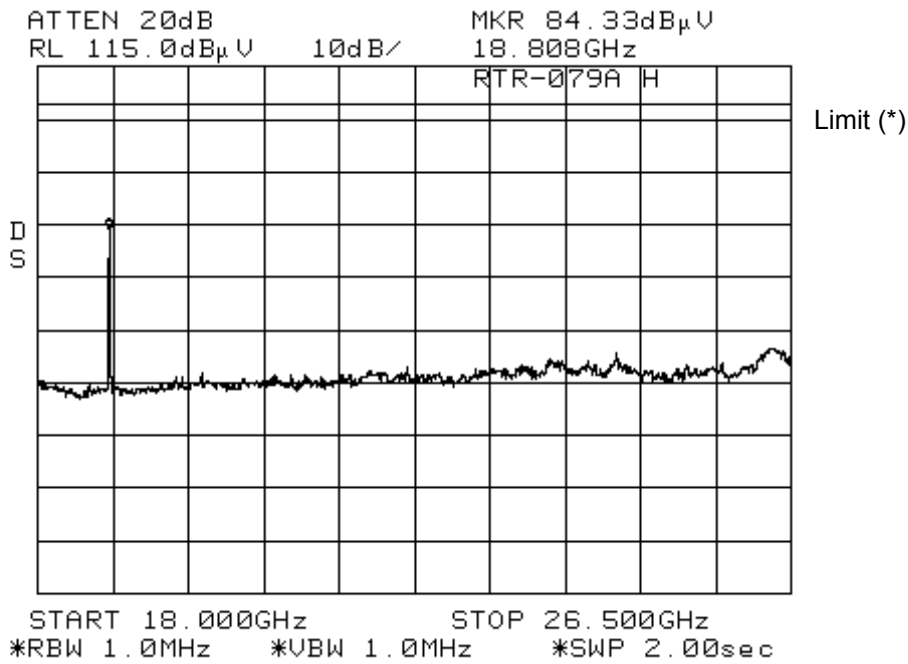

- for Vertical

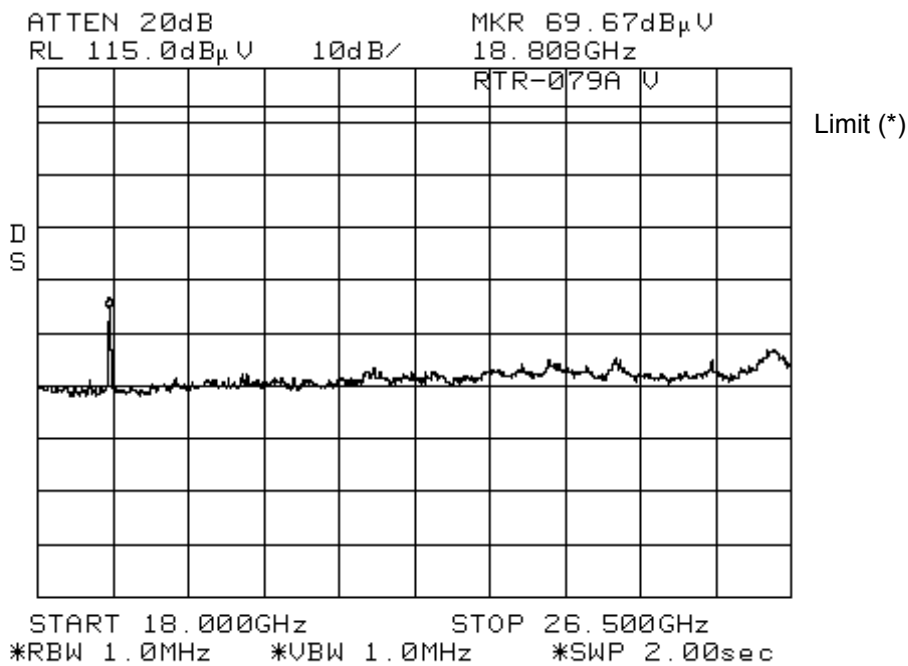

(\*) The Limit is represented by the voltage value, which was derived from the electric field strength value with Antenna factor, Cable loss and Amp. gain.

Minimum limit line for the frequency range of 18 GHz to 26.5 GHz is indicated in the above plots.

(5) for 26.5 GHz to 40 GHz  
- for Horizontal

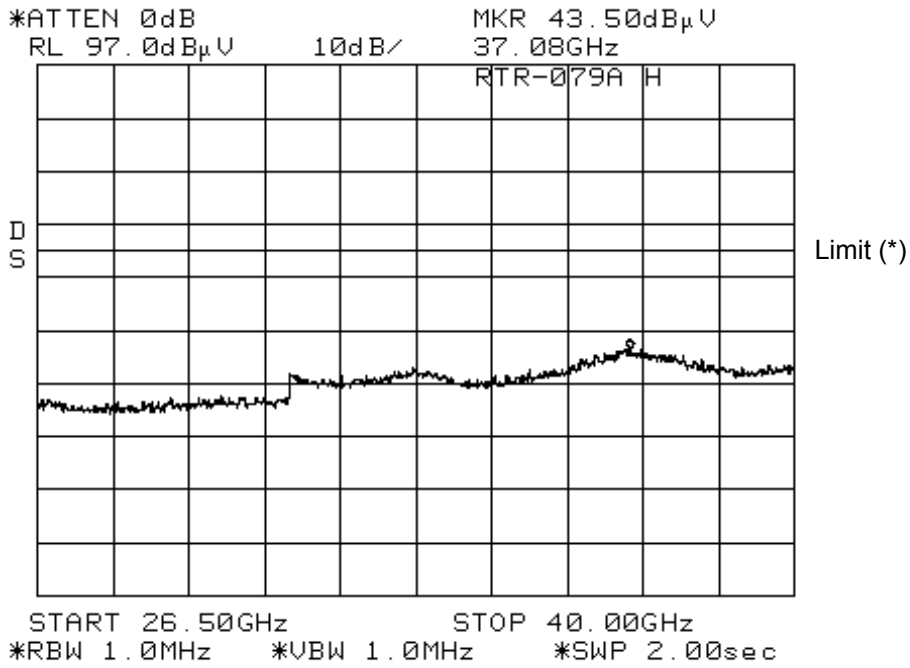

- for Vertical

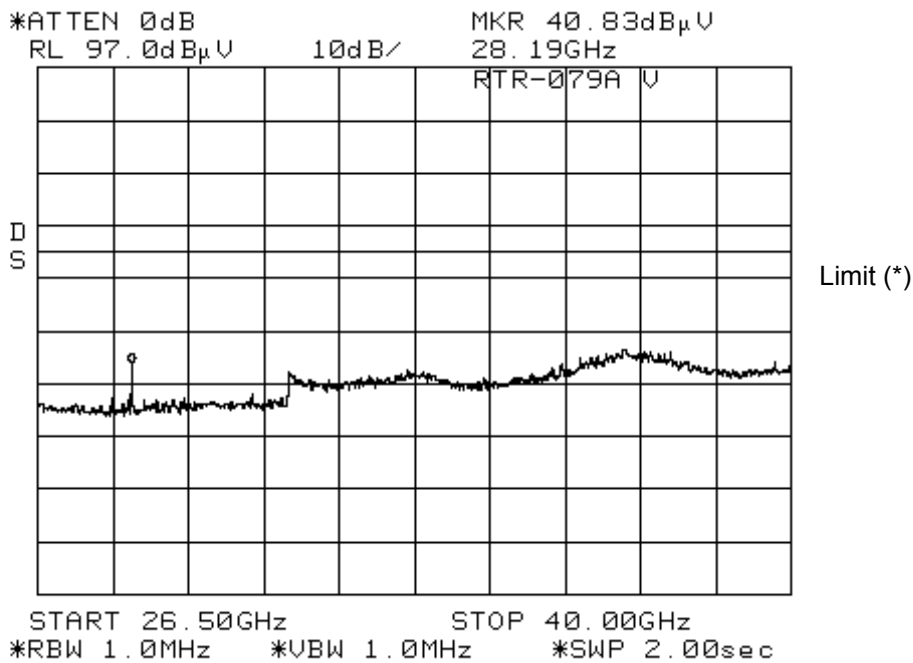

(\*) Emission limit was converted from the electric field strength into the voltage values with Antenna factor, Cable loss and Amp. gain added to the calculation.

Minimum limit line for the frequency range of 26.5 GHz to 40 GHz is indicated in the above plots.



(3) 30 MHz – 100 MHz: Limit = 4000  $\mu$ W (+6 dBm)

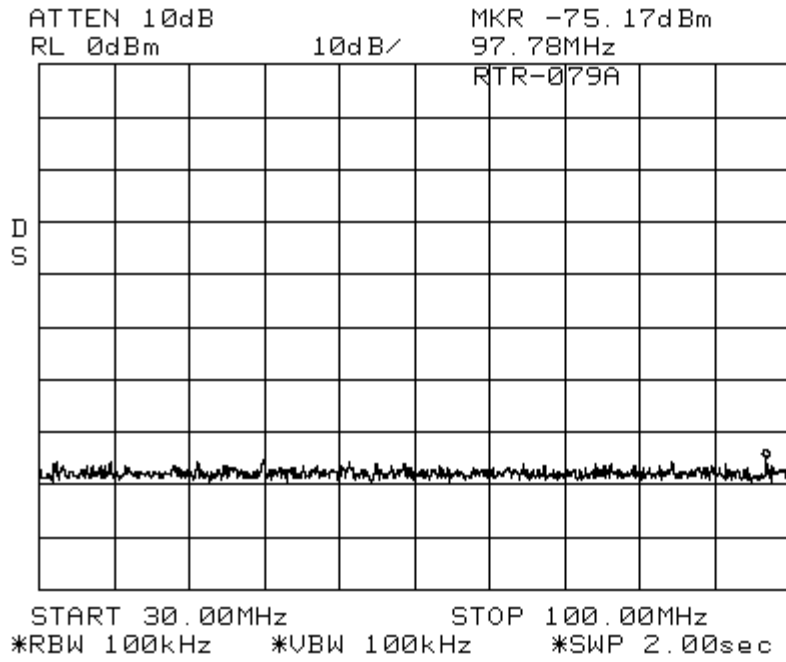

(4) 100 MHz – 300 MHz: Limit = 40000  $\mu$ W (+16 dBm)

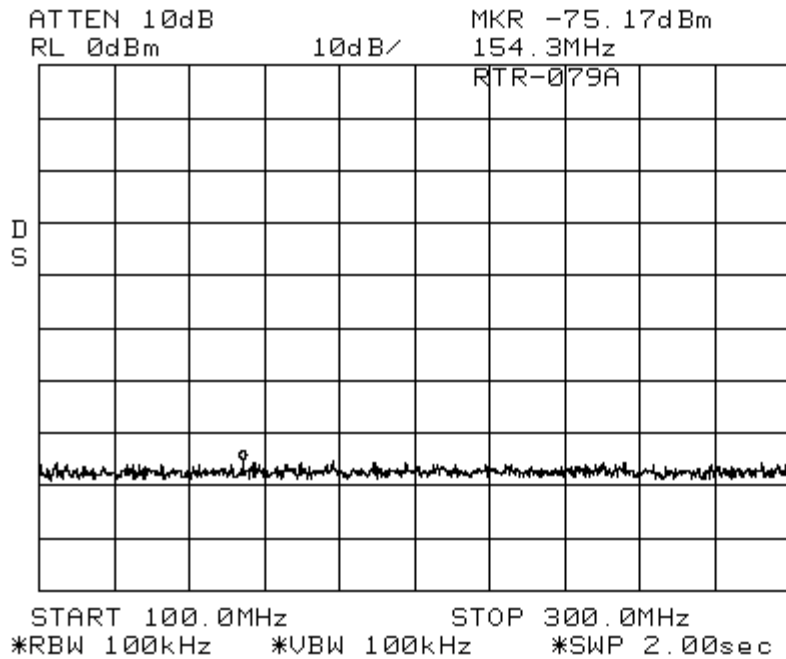

(5) 300 MHz – 1 GHz: Limit = 400000 µW (+26 dBm)

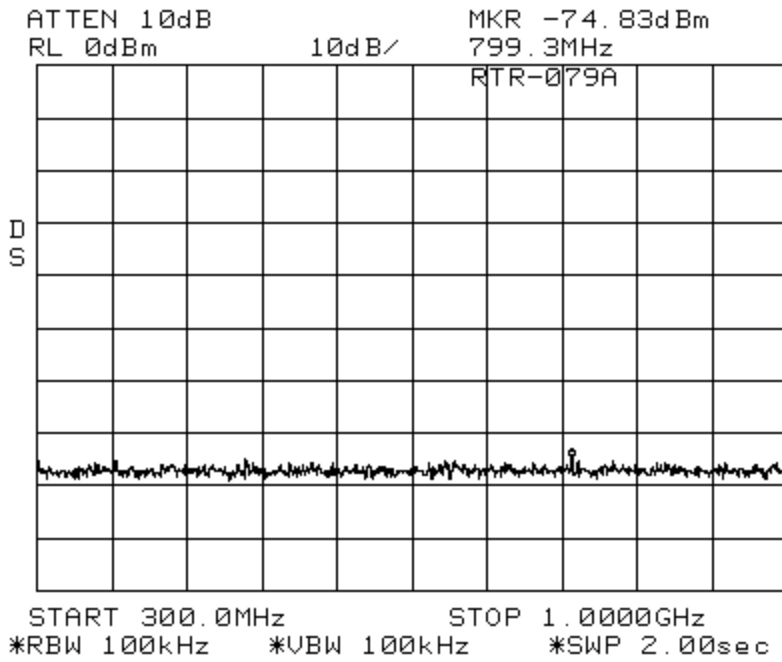

(6) 1 GHz – 10 GHz: Limit = 400000 µW (+26 dBm)

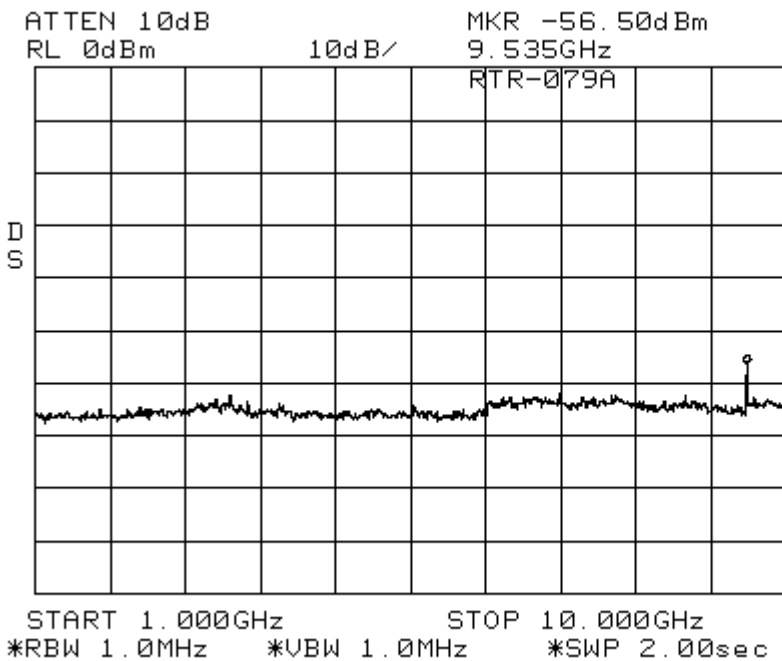

Spurious frequency: 9.535 GHz, Cable loss: 1.8 dB

Spurious Strength =  $10^{((-54.70+1.8)/10)}$  mW = 0.003 µW



(9) 26.5 GHz – 33 GHz: Limit = 400000 µW (+26 dBm)

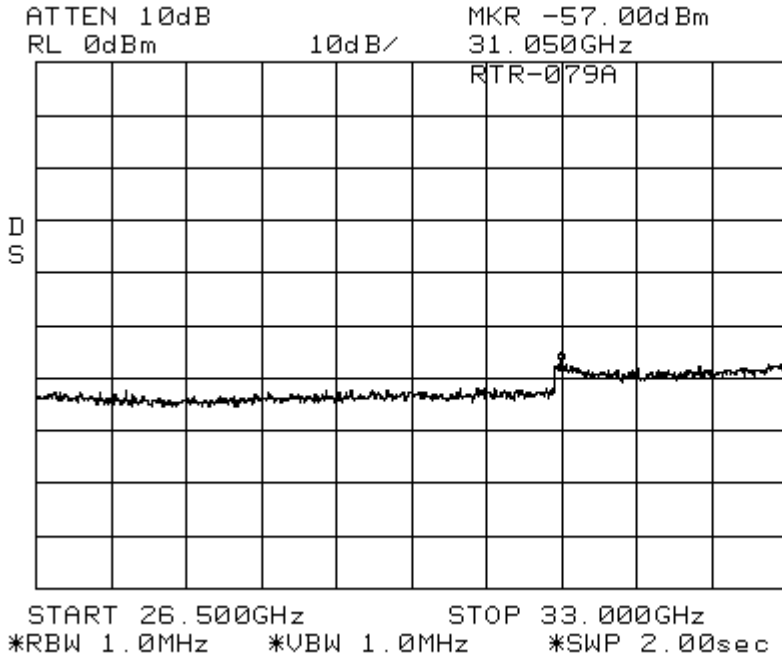

(10) 33 GHz – 40 GHz: Limit = 400000 µW (+26 dBm)

