

LABOTECH

TECHNICAL INFORMATION

TEST REPORT ON THE PERFORMANCE OF MARINE RADAR

Trade Name : FURUNO

Transceiver Type : RTR-075

Report no.: FLI 12-02-032

Date of issue: July 26, 2002

Furuno Labotech International Co., Ltd.

9-52 Ashihara-cho, Nishinomiya City, Hyogo 662-8580, Japan

Tel: +81-798-63-1094 Fax: +81-798-63-1098

All tests were performed in Furuno Labotech International Co., Ltd.
All data herein contained is true and correct to our best knowledge.

All tests were performed by:

Name : Katsumi Imamura

Function : Test Engineer

Signature 

Review and report by:

Name : Toshiro Segawa

Function : Manager, QA

Signature 

This report has been verified and approved by:

Date : July 26, 2002

Name : Mitsuyoshi Komori

Function : Manager, Technical Section

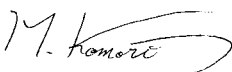
Signature 

* * * * * **C O N T E N T S** * * * * *

1 General Information 3

2 Identification of Equipment (FCC Rule § 2.925)..... 9

3 Test data 10

3.1 RF Power Output (FCC Rule § 2.1046) 10

3.2 Modulation Characteristics (FCC Rule § 2.1047) 13

3.3 Occupied Bandwidth (FCC Rule § 2.1049)..... 18

3.4 Spurious Emissions at Antenna Terminal (FCC Rule § 2.1051) 20

3.5 Field Strength of Spurious Radiation (FCC Rule § 2.1053) 23

3.6 Frequency Stability (FCC Rule § 2.1055) 25

3.7 Suppression of Interference Aboard Ships (FCC Rule § 80.217)..... 28

4 Photographs to Reveal Equipment Construction and Layout (FCC Rule § 2.1033)..... 32

5 Description of Circuitry and Devices (FCC Rules § 2.1033)..... 33

5.1 Function of Each Semiconductor or Active Device 33

5.2 Description of the circuits employed for suppression of spurious radiation, for limiting or shaping the control pulse, and for limiting or controlling power..... 36

6 Operator ' s Manual Incl. Circuit Diagrams (FCC Rule § 2.1033)..... 39

Attachment A [Test data for 3.4 Spurious Emissions at Antenna Terminal] A.1 - A.6

Attachment B [Test data for 3.5 Field Strength of Spurious Radiation] B.1 - B.3

Attachment C [Test data for 3.7 Suppression of Interference Aboard Ships] C.1 - C.21

Attachment D [List of Test/ Measuring Equipment] D.1 - D.3

Attachment E [Photographs of the EUT] E.1 - E.22

1 General Information**1.1 General**

(a) Manufacturer: Furuno Electric Co., Ltd.
Ashihara-cho 9-52, Nishinomiya-city, 662-8580 Japan

(b) Model: MODEL 1823C

	Type	Serial Number
Display unit	RDP-139	4309-4483
Antenna unit	RSB-0094	R129-0010
Transceiver:	RTR-075	(contained in Antenna unit)
Radiator:		

(c) Primary Function: Search, Navigation and anticollision

(d) Discrimination

Range Discrimination: 20 meters on a range scale of 1.5 nm

Bearing Discrimination: 5.2° on a range scale of 1.5 nm

(e) Minimum Range: 25 meters on a range scale of 0.25 nm

(f) Frequency Range: Fixed frequency, X-band

Type of Emission: P0N

(g) Power Supply: 12 - 24 VDC

1.2 Antenna Unit**1.2.1 Transceiver**

Type: RTR-075

(1) Transmitter

(a) Assignable Frequency for Shipborne Radar:

Between 9300 and 9500 MHz (FCC Rule § 80.375 (d)-(1))

(b) Type of RF Generator

Magnetron Type: E3588

Peak Output Power: 2.2 kW nominal

(c) Magnetron Ratings

Center frequency of Magnetron: 9410 MHz

Tolerances

E3588

Manufacturing: ± 30 MHz

Pulling: 27 MHz

Tolerance for 20°C temperature variation: -5 MHz

(d) Guard Band:

Guard Band is specified to be equal to $1.5/T$ MHz, where "T" is the pulselength in microseconds. See para (e). (FCC Rule § 80.209(b))

(e) Pulse Characteristics:

Range Scale (nm)	(Short)	(Middle)	(Long)
	<u>0.125</u>		
	0.25		
	0.5		
	0.75		
	1		
	1.5	1.5	
		<u>2</u>	
		3	3
			4
			6
			8
			12
			16
			<u>24</u>
Pulselength (µs)	0.08	0.30	0.80
P.R.R.(Hz)	2100	1200	600
Duty cycle	1.68×10^{-4}	3.60×10^{-4}	4.80×10^{-4}
Guard Band (MHz)	18.75	5.00	1.88

Note 1: Tests were carried out for the underlined Range Scales.

(2) Modulator

- (a) FET Type: 2SK1449
 Trigger Voltage: Approx. +10 VDC positive

(3) Receiver

- (a) Passband (MHz)
 RF Stage: 100 MHz
 IF Stage:

Pulselength	Short	Middle	Long
(MHz)	30	30	3

Video Amp.:

Pulse length	Short	Middle	Long
(MHz)	30	30	30

- (b) Gain (overall) (dB): Sufficient to cause limiting, approximately 100
- (c) Overall Noise Figure (dB): 9 (max.)
- (d) Video Output Voltage (V): 4 V positive across 75 ohms
- (e) Features Provided:
Sensitivity Time Controls (Anti-clutter Sea),
Fast Time Constant (Anti-clutter Rain)
- (f) If receiver is tunable, describe method of adjusting frequency:
Adjustment of tuning voltage of receiver local oscillator
(Automatic and manual)

1.2.2 Antenna

- (a) Antenna Rotation ON-OFF Switch:
Not Provided.
- (b) Reflector: Microstrip antenna
- (c) Type of Beam: Vertical fan
- (d) Beam Width (between half-Radiator power points)
- | | |
|----------------|-----|
| Horizontal (°) | 5.2 |
| Vertical (°) | 25 |
- (e) Polarization: Horizontal
- (f) Antenna Gain: 20 dB or more
- (g) Attenuation of Major Side Lobes with respect to main beam:
- | | |
|------------------------|----------------|
| Within $\pm 20^\circ$ | -19 dB or less |
| Outside $\pm 20^\circ$ | -21 dB or less |
- (h) Scanning (rotating or oscillating):
Rotating over 360° continuously clockwise
- (i) Antenna Rotation Rate: 30 rpm for Short Range setting,
24 rpm for Middle and Long Range settings.
- (j) Number of Degrees Scanned: 360°
- (k) Sector Scan: Not provided.
- (l) Type of Transmission System: Contained in scanner unit
- (m) Rated Loss of Transmission System per hundred feet:
None. Transmission path is only in the antenna scanner unit.

1.3 Display Unit

- (a) Type: 10.4 (in.) Color LCD,
640 X 480 pixels
- (b) Size of Indicator: 10.4 in. diagonal
effective dia. 152 mm
- (c) Sweep Linearity: 2 % on all ranges
- (d) Range Scales:

Range (nm)	Number of Range Rings	Range Ring Interval (nm)
0.125	2	0.0625
0.25	2	0.125
0.5	4	0.125
0.75	3	0.25
1	4	0.25
1.5	3	0.5
2	4	0.5
3	3	1
4	4	1
6	3	2
8	4	2
12	4	3
16	4	4
24	4	6

- (e) Range Ring Accuracy: Better than 0.9 % of maximum scale in use
or 8 m, whichever is the greater
- (f) Overall Bearing Accuracy from Scanner to Display:
Better than 1°
- (g) Target Plot Facility: Simulated afterglow in low shade
- (h) Heading Indicator: Provided, automatic alignment. Heading Line and Heading
Marker
- (i) True Bearing Indicator: Not provided

1.4 Functional Controls

Range selector	Power Switch	
STC control ²⁾	Gain control ²⁾	Panel dimmer ²⁾
Heading line off	Echo stretch ²⁾	MENU

Guard zone ²⁾	Range ring on/off ²⁾	Interference rejecter ²⁾
ST-BY/TX ²⁾	Trackball (VRM/EBL/GUARD)	
VRM on/off ²⁾	SHIFT (Offcenter)	Range set ²⁾
Zoom ²⁾	EBL on/off ²⁾	Echo Trail ²⁾
PLOT color ²⁾	Navigation on/off ^{1), 2)}	Anchor watch ²⁾
Display brilliance ²⁾	TRU/REL ^{2), 3)}	Mode ^{2), 3)}
TLL ^{1), 2), 3)}	Chart display ²⁾	Waypoint ²⁾
Date box ^{1), 2)}		

Note: ¹⁾ Valid when interfaced with navaid

²⁾ Selected on menu

³⁾ Valid when interfaced with gyrocompass

1.5 Operational Features

(a) Is positive means provided to indicate whether or not the overall operation of the equipment is such that it may be relied upon to provide effective operation in accordance with its primary function:

Yes (Magnetron/Xtal checker)

(b) Is the equipment for continuous operation: Yes

(c) Is provision made for operation with shore based radar beacons (RACONS):

Yes (RACONS and SART)

1.6 Line Power Supply Requirements

(a) Input Voltage: 12 - 24 VDC

(b) Power Drain: 90 W

1.7 Construction Features

(a) Does equipment embody replacement units with chassis type assembly: Yes

(b) Are fuse alarms provided: Fuses are provided.

(c) State units that are weatherproof: Antenna Unit (IEC 60529 - IPX6)

(d) If all units are not housed in a single container, indicate number and give description of individual units:

1 x Display Unit	Type:	RDP-139
1 x Antenna Unit	Type:	RSB-0094 (24 or 30 rpm)
Transceiver	Type:	RTR-075 (contained in the Antenna unit)

(e) Approximate Weight of Complete Installation:

Display Unit: 6.0 kg

Antenna Unit: 4.5 kg

(f) Approximate space required for installation excluding scanner

Display Unit: 383 mm (W) X 262 mm (H) X 180 mm (D)

2 Identification of Equipment (FCC Rule § 2.925)

The following nameplates are permanently fixed on the corresponding equipment units.

FCC ID: **ADB9ZWRTR075**

Material of nameplate: Polyester film, 0.1 mm thick

MARINE RADAR ANTENNA UNIT	
TYPE	RSB-0094
SER. NO.	R129-
FCC ID:	ADB9ZWRTR075
FURUNO USA, INC.	
COMPASS SAFE DISTANCE	
STD <input type="text"/> m	STEER <input type="text"/> m
FURUNO ELECTRIC CO., LTD.	
9-52 Ashihara-Cho, Nishinomiya City, Japan	
MADE IN JAPAN	
CE 0560	

Fig. 2.1
Nameplate for
Antenna Unit

MARINE RADAR	
<input type="text"/>	
DISPLAY UNIT	
TYPE	RDP-139
INPUT	12 - 24 VDC
SER. NO.	4309-
COMPASS SAFE DISTANCE	
STD <input type="text"/> m	STEER <input type="text"/> m
FURUNO ELECTRIC CO., LTD.	
9-52 Ashihara-Cho, Nishinomiya City, Japan	
MADE IN JAPAN	
CE 0560	

Fig. 2.2
Nameplate for
Display Unit

3 Test data**3.1 RF Power Output (FCC Rule § 2.1046)****3.1.1 Microwave characteristics**

The peak voltage was determined using the divider having a ratio of 1000 to 1 and the oscilloscope. Current pulse was viewed across the wideband current transformer with output voltage per ampere 1.00.

(1) Nominal values

Pulselength	Short	Middle	Long
Range scale (nm)	0.125	2	24
Pulselength (μ s)	0.08	0.30	0.80
PRR (Hz)	2100	1200	600
Duty cycle	1.68×10^{-4}	3.60×10^{-4}	4.80×10^{-4}
Guard band (MHz)	18.75	5.00	1.88

(2) Measured values**Magnetron input pulse voltage**

Magnetron input pulse voltage was measured at its cathode using the oscilloscope and divider with ratio 1000 to 1.

Pulselength	Short	Middle	Long
Directional coupler attenuation (dB)	40.44	40.44	40.44
Magnetron input voltage (kV)	2.4	2.4	2.4
Pulselength (μ s) (50 % amplitude)	0.242	0.520	0.996
Rise time (μ s) (10 - 90 % amplitude)	0.084	0.124	0.122
Decay time (μ s) (90 - 10 % amplitude)	0.272	0.320	0.304

Magnetron input pulse current

Magnetron input pulse current was observed across the wideband current transformer with output voltage per ampere 1.00.

Pulselength	Short	Middle	Long
Magnetron input current (A)	2.0	2.2	2.2
Pulselength (μ s) (50 % amplitude)	0.066	0.270	0.730
Rise time (μ s) (10 - 90 % amplitude)	0.032	0.110	0.128
Decay time (μ s) (90 - 10 % amplitude)	0.048	0.045	0.044

RF envelope of the magnetron output pulse

The RF envelope of the magnetron output pulse was measured using a diode and the oscilloscope with the following results:

Pulselength	Short	Middle	Long
Pulselength (μ s) (-3 dB points)	0.070	0.277	0.744
Rise time (μ s) (10 - 90 % amplitude)	0.028	0.060	0.064
Decay time (μ s) (90 - 10 % amplitude)	0.051	0.051	0.058

Estimated efficiency

The estimated efficiency of the RF generator (magnetron) was determined by the following measurements and calculation. Power output from magnetron was measured using the directional coupler, power meter and the oscilloscope.

Pulselength	Short	Middle	Long
Range scale (nm)	0.125	2	24
P.R.R (Hz)	2129.9	1226.3	622.6
Duty cycle	1.49×10^{-4}	3.40×10^{-4}	4.63×10^{-4}
Magnetron input, av. (W)	0.72	1.79	2.45
Magnetron input, peak (kW)	4.80	5.28	5.28
Power meter reading (mW)	0.0194	0.0445	0.0643

Pulselength	Short	Middle	Long
Magnetron output, av. (W)	0.215	0.492	0.712
Spurious response limits (dB)	36.32	39.92	41.52
Magnetron Output, peak (kW):	1.44	1.45	1.54
Magnetron efficiency (%):	30.00	27.46	29.09

Peak Power Input to RF Generator : 5.1 kW

Estimated Efficiency of RF Generator : 28.8 %

3.2 Modulation Characteristics (FCC Rule § 2.1047)

3.2.1 FET Trigger Pulse

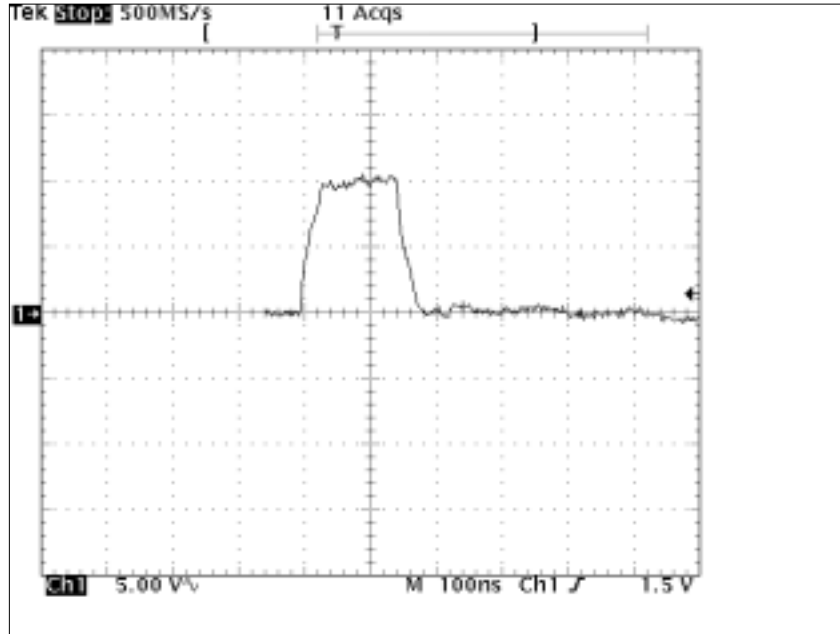

Fig. 3.2.1.1 Typical waveform of Trigger Pulse Scale: 5 V/div., 100 ns/div.

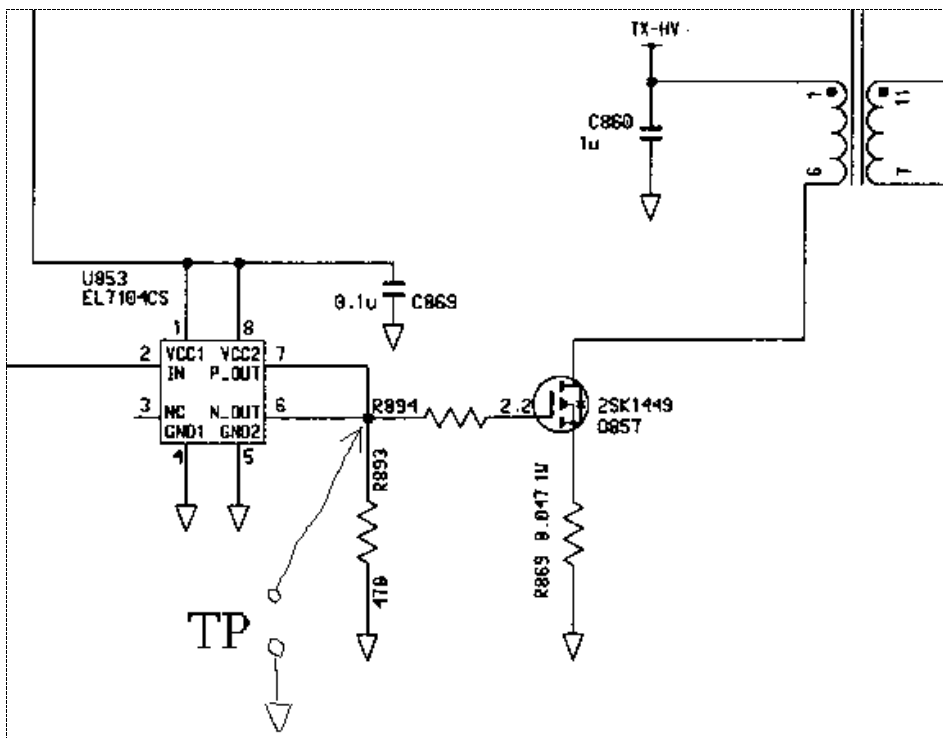

Fig. 3.2.1.2 Test Point for Trigger Pulse
(in MD Board (03P9270) of Radar Antenna Unit)

3.2.2 Trigger Pulse at Magnetron Cathode

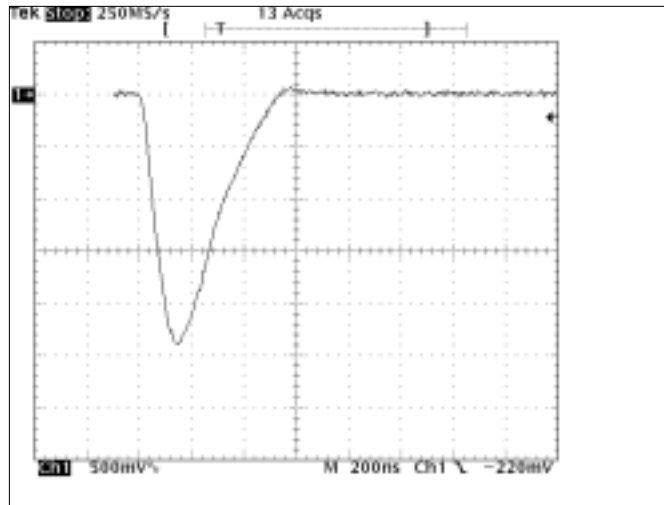

Fig. 3.2.2.1

Short Pulse (0.125 nm Range)

Scale: 500 V/div. 200 ns/div.

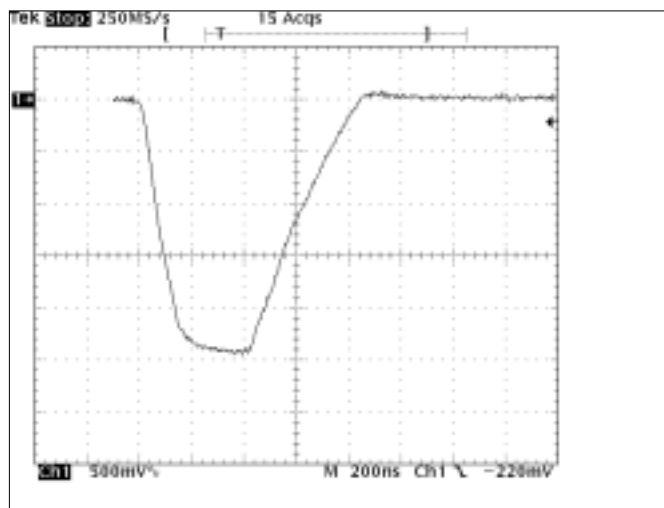

Fig. 3.2.2.2

Middle Pulse (2 nm Range)

Scale: 500 V/div. 200 ns/div.

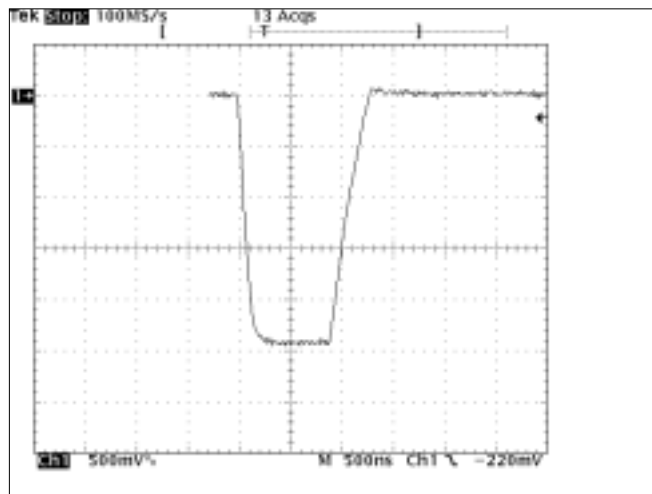

Fig. 3.2.2.3

Long Pulse (24 nm Range)

Scale: 500 V/div. 500 ns/div.

3.2.3 Magnetron Output (detected):

3.2.3.1 Setup for Measurement:

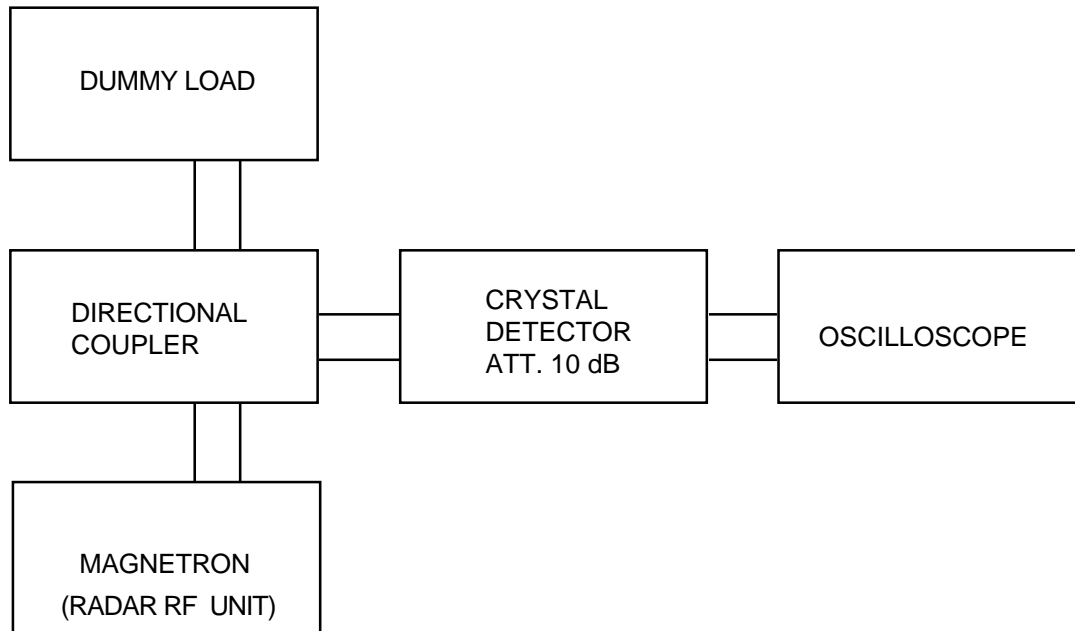

Fig. 3.2.3.1

3.2.3.2 Measuring Equipment List:

See Attachment D [List of Test/Measuring Equipment].

3.2.3.3 Measured Data:

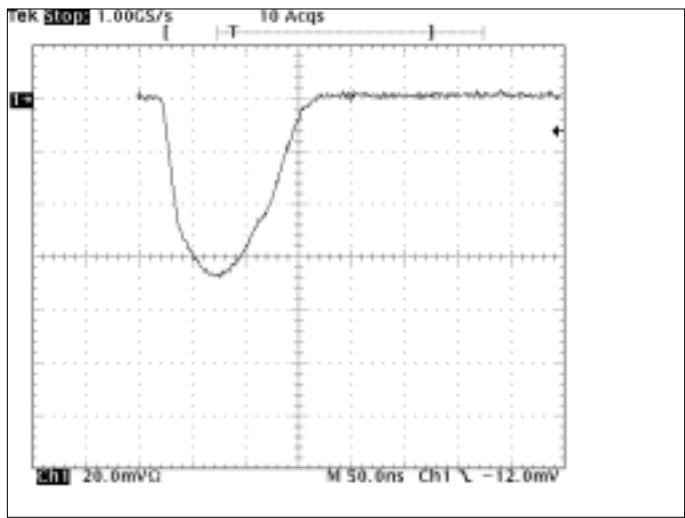

Fig. 3.2.3.2 Short Pulse (0.125 nm Range) Scale: 20 mV/div. 50 ns/div.

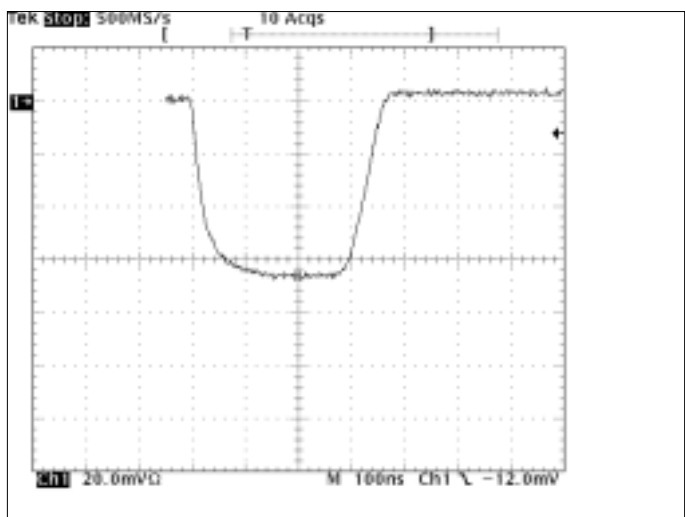

Fig. 3.2.3.3 Middle Pulse (2 nm Range) Scale: 20 mV/div. 100 ns/div.

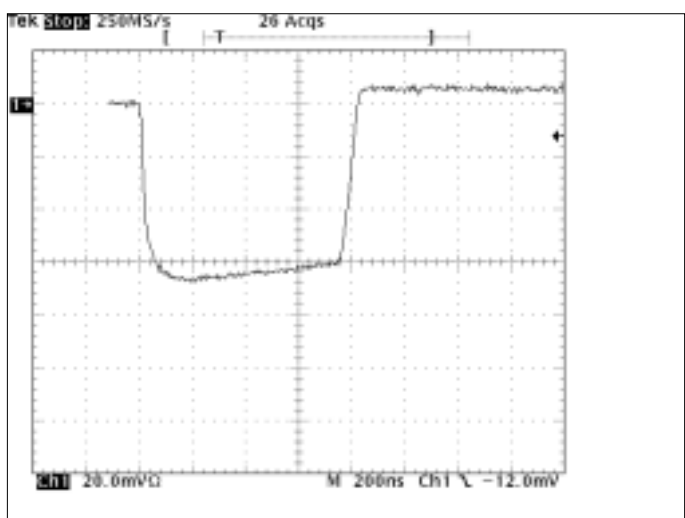

Fig. 3.2.3.4 Long Pulse (24 nm Range) Scale: 20 mV/div. 200 ns/div.

3.2.4 Radar Pulse Spectrum:

Measured by the spectrum analyzer.

(Test Equipment Setup and Measuring Equipment List are same as Clause 3.4.1 and 3.4.2.)

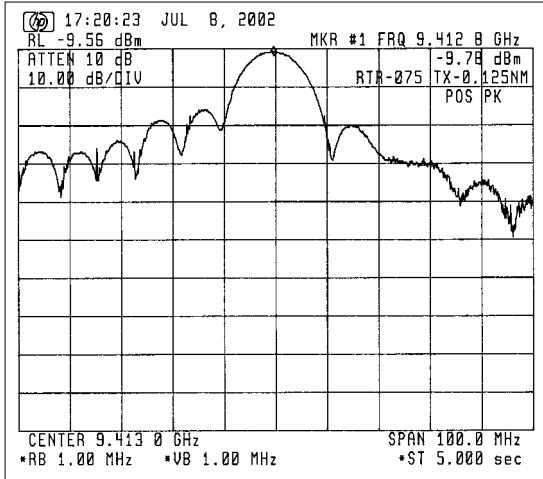

Fig. 3.2.4.1 For Short Pulse (0.125 nm Range)

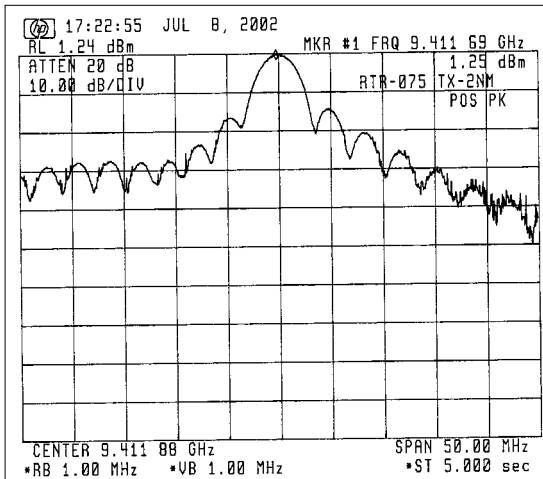

Fig. 3.2.4.2 For Middle Pulse (2 nm Range)

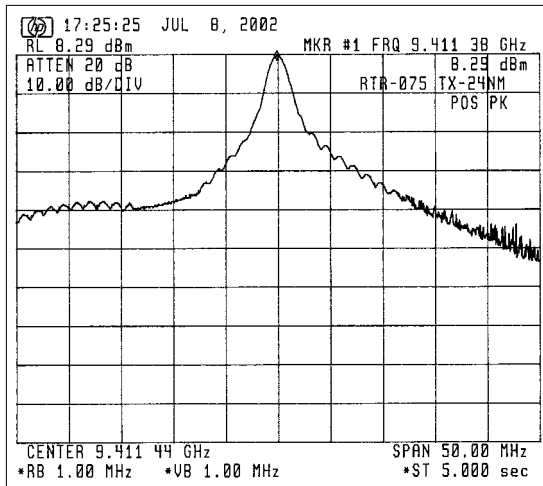

Fig. 3.2.4.3 For Long Pulse (24 nm Range)

3.3 Occupied Bandwidth (FCC Rule § 2.1049)**3.3.1 Measuring Method**

FCC rule 47 CFR 2.1049 requires measurements of the occupied bandwidth which is defined in the same section as "the frequency bandwidth such that, below its lower and above its upper frequency limits, the mean powers radiated are each equal to 0.5 percent of the total mean power radiated by a given emission." To obtain the occupied bandwidth of the radar transmitter, a special program (program list shown below) was loaded to the Hewlett-Packard spectrum analyzer and run by entering the HP-provided POWER BANDWIDTH calculation command [PWRBW].

The result was automatically displayed on the screen on the spectrum analyzer as:

POWER_BW=----- MHz

```

10 ! HP_71000 DOWNLOAD PROGRAM
20 ASSIGN @Sa TO 718
30 CLEAR @Sa
40 CALL M_ain(@Sa)
50 LOCAL @Sa
60 END
70 !
80 SUB M_ain(@Sa)
90 M_ain: !
100 CALL Pwr_bw(@Sa)
110 CALL Limit_line(@Sa)
120 !
130 OUTPUT @Sa;"VARDEF K_ey,0;";
140 !
150 OUTPUT @Sa;"FUNCDEF D_LP,^";
160 OUTPUT @Sa;"MOV K_ey,0;";
170 !
180 Main_menu: !
190 OUTPUT @Sa;"REPEAT;";
200 OUTPUT @Sa;"READMENU K_ey;";
210 ! location: %Top---Bottom-%
220 OUTPUT @Sa;"1,%Limit line %,";
230 OUTPUT @Sa;"2,%Power bw %,";
240 OUTPUT @Sa;"14, % Exit%,";
250 !
260 OUTPUT @Sa;"IF K_ey,EQ,1;THEN;LIMIT_LINE;";
270 OUTPUT @Sa;"ELSIF K_ey,EQ,2;THEN;PWR_BW;";
280 OUTPUT @Sa;"ELSIF K_ey,EQ,14;THEN;ABORT;";
290 OUTPUT @Sa;"ENDIF;";
300 OUTPUT @Sa;"UNTIL K_ey,EQ,14;";
310 OUTPUT @Sa;"IP;TS;";
320 OUTPUT @Sa;"ADORT;";
330 OUTPUT @Sa;"^"
340 !
350 Define_keydef: !
360 OUTPUT @Sa;"KEYDEF 7,D_LP, %DLP TEST%,";
370 !
380 OUTPUT @Sa;"FUNCDEF D,^";
390 OUTPUT @Sa;"KEYPST;";
400 OUTPUT @Sa;"^"
410 !
420 SUBEND
430 !
440 SUB Limit_line(@Sa)
450 Limit_line: !
460 OUTPUT @Sa;"CLR DSP;";
470 OUTPUT @Sa;"FUNCDEF LIMIT_LINE,^";
480 OUTPUT @Sa;"PU;PA 0,654;";
490 OUTPUT @Sa;"LINET 1;";
500 OUTPUT @Sa;"PD;PA 100,654;";
510 OUTPUT @Sa;"PU;PA 201,654;";
520 OUTPUT @Sa;"PD;PA 300,654;";
530 OUTPUT @Sa;"PU;PA 105,630;";
540 OUTPUT @Sa;"TEXT @-35dB@";
550 OUTPUT @Sa;"PU;PA 205,720;";
560 OUTPUT @Sa;"TEXT @-25dB@";
570 OUTPUT @Sa;"PU;PA 301,743;";
580 OUTPUT @Sa;"LINET 1;";
590 OUTPUT @Sa;"PD;PA 400,743;";
600 OUTPUT @Sa;"PU;PA 601,743;";
610 OUTPUT @Sa;"LINET 1;";
620 OUTPUT @Sa;"PD;PA 700,743;";
630 OUTPUT @Sa;"PU;PA 701,654;";
640 OUTPUT @Sa;"LINET 1;";
650 OUTPUT @Sa;"PD;PA 1000,654;HD;";
660 OUTPUT @Sa;"^"
670 SUBEND
680 SUB Pwr_bw(@Sa)
690 Pwr_bw: !
700 ! Calculating Power band width
710 OUTPUT @Sa;"VARDEF P_bw,0;";
720 OUTPUT @Sa;"FUNCDEF PWR_BW,^";
730 OUTPUT @Sa;"CLRW TRA;";
740 OUTPUT @Sa;"CLR DSP;";
750 OUTPUT @Sa;"SNGLS;";
760 OUTPUT @Sa;"MXMH TRA;TS;TS;TS;";
770 OUTPUT @Sa;"MOV P_bw,PWRBW TRA,99.0;";
780 OUTPUT @Sa;"DIV P_bw,P_bw,1000000;";
790 OUTPUT @Sa;"PU;PA 10,800;HD;";
800 OUTPUT @Sa;"TEXT @POWER_BW = @;";
810 OUTPUT @Sa;"DSPLY P_bw,8,3;";
820 OUTPUT @Sa;"TEXT @ MHz @;";
830 OUTPUT @Sa;"^"
840 SUBEND

```

Fig. 3.3.1

Program for Calculation of Occupied Bandwidth

3.3.2 Test Equipment Setup:

Same as Clause 3.4.1.

3.3.3 Measuring Equipment List:

Same as Clause 3.4.2.

3.3.4 Test Result:

The test result is shown below.

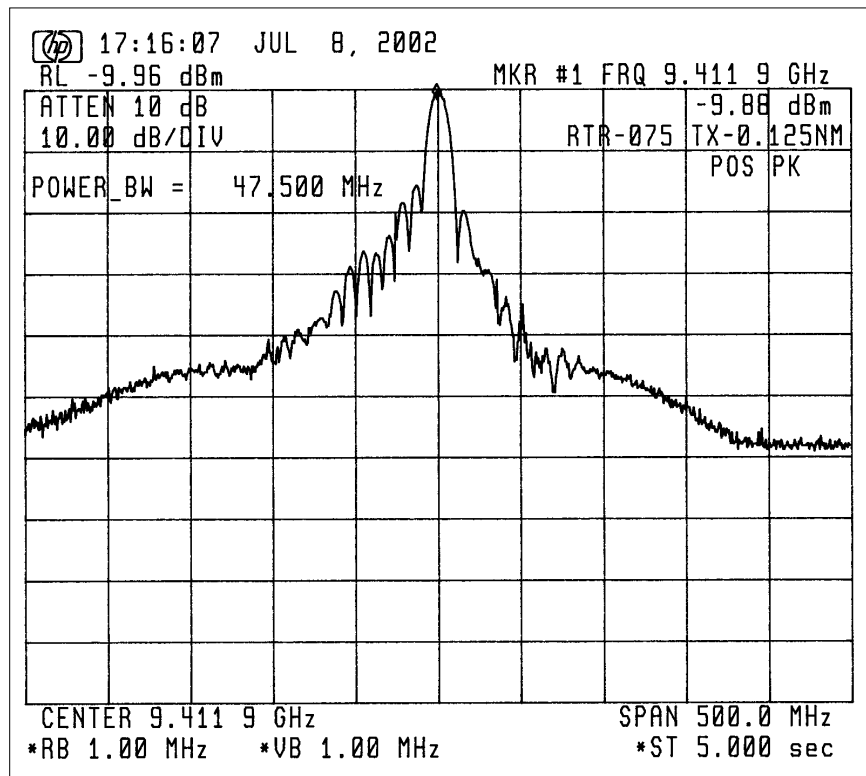

Fig. 3.3.2 Measurement of Occupied Bandwidth

Occupied bandwidth = 47.500 MHz

3.4 Spurious Emissions at Antenna Terminal (FCC Rule § 2.1051)

3.4.1 Test Equipment Setup:

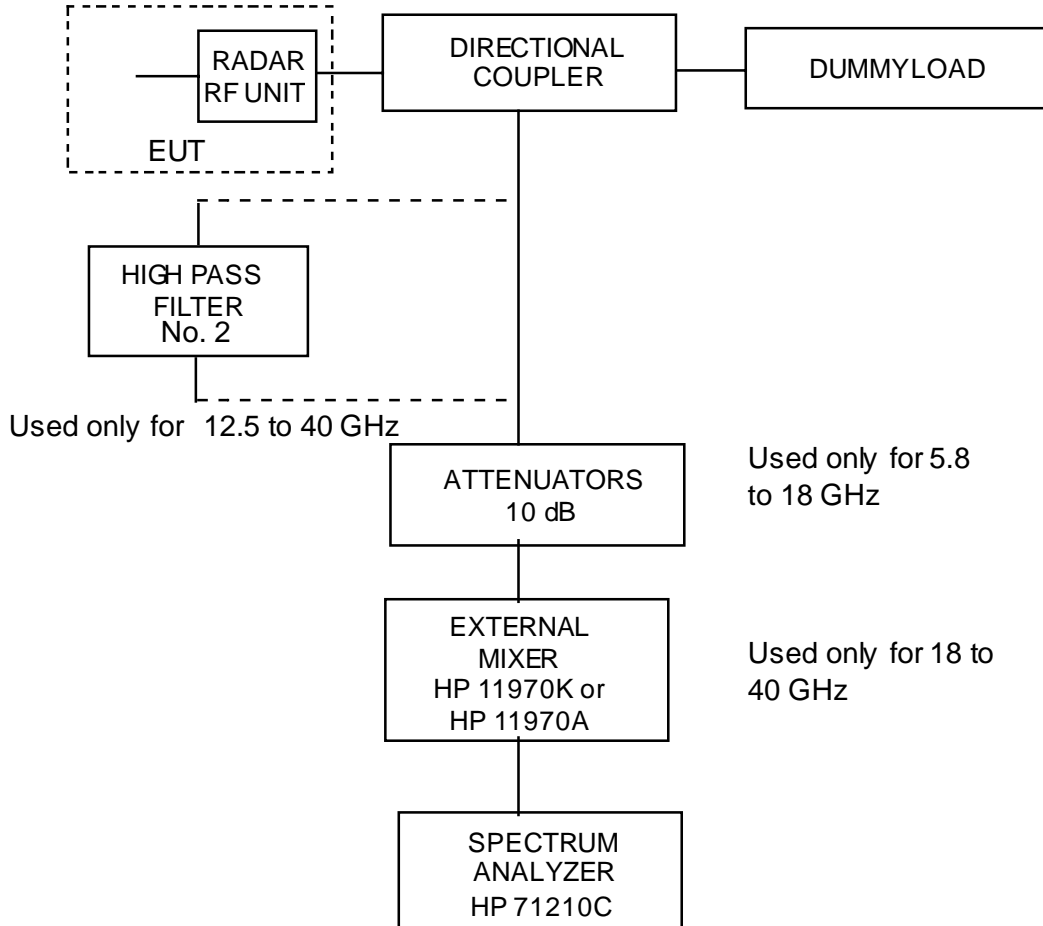

Fig. 3.4.1

3.4.2 Measuring Equipment List:

See Attachment D [List of Test/Measuring Equipment].

Note: The characteristic of High Pass Filter (No. 2) is described in Fig. 3.4.6.

3.4.3 Test Conditions:

Radar Range Settings: 0.125 nm (Short)/2 nm (Middle)/ 24 nm (Long)

3.4.4 Emission Limits:

(a) Frequency Range (FCC Rule § 2.1057(1)) : 10 kHz - 40 GHz

(b) Emission Limits (FCC Rule § 80.211) :

Frequency removed from the assigned frequency	Frequency (Hz)	Emission attenuation (mean power, dB)
50 - 100 % (of the authorized bandwidth)	9310 - 9360 M	At least 25
	9460 - 9510 M	
100 - 250 %	9160 - 9310 M	At least 35
	9510 - 9660M	
more than 250 %	10 k - 9160M	At least $43 + 10 \log_{10}$ (mean power in watts)
	9660 - 40,000 M	

Note : (1) Assigned frequency (center frequency) = 9410 MHz

(2) Authorized bandwidth = 100 MHz

3.4.5 Test Results:

As shown in Attachment A, the spurious emissions at antenna terminal of EUT are found lower than the specified limits.

(Note: Spurious emissions for 10 kHz to 5 GHz are not found due to the antenna terminal structure. (Waveguide tube)).

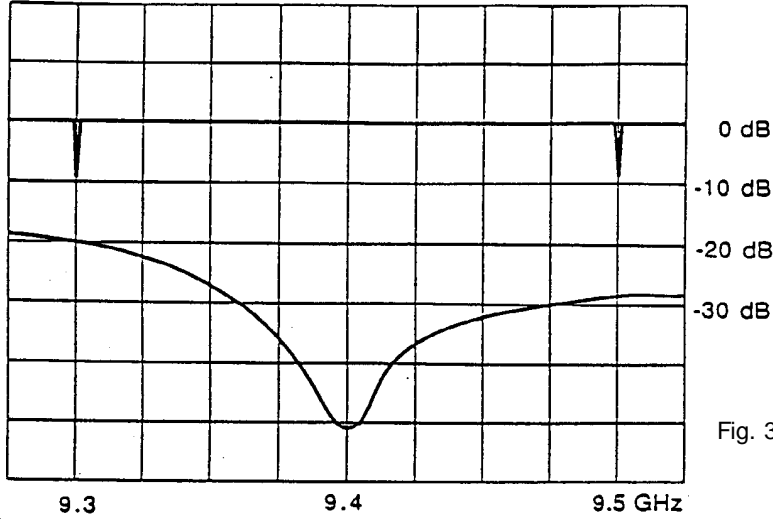
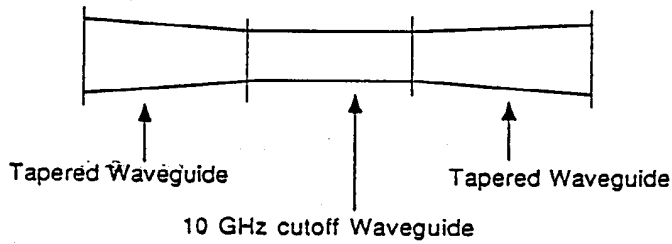

Fig. 3.4.5

Characteristic of Filter No. 2 (for X-band)



This filter is used to filter out the high level fundamental signal to avoid damage to the analyzer.

High Pass Filter Construction

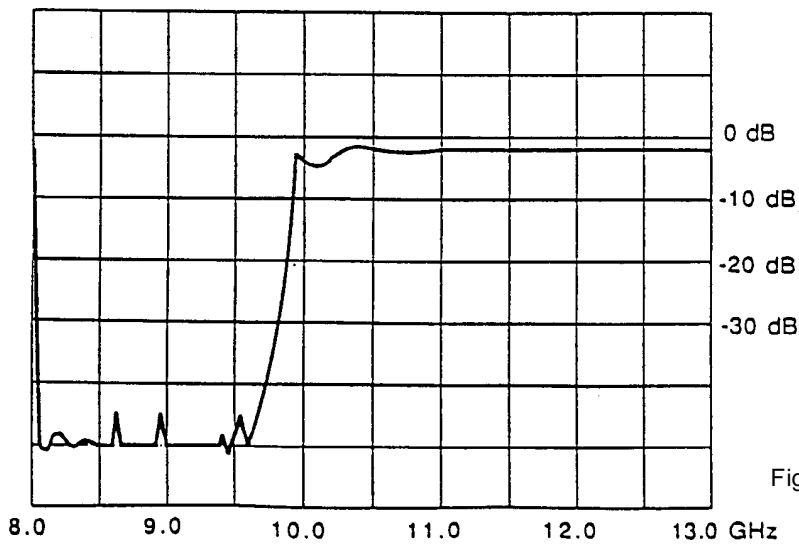

Fig. 3.4.6

3.5 Field Strength of Spurious Radiation (FCC Rule § 2.1053)

3.5.1 Test Site: Rooftop of 6-story building,
 FURUNO ELECTRIC CO., LTD.
 Ashihara-cho 9-52, Nishinomiya-city, 662-8580 Japan

3.5.2 Distance between the radar set and measuring antenna: 10 m

3.5.3 Radar Range settings: 0.125 nm (Short)/2 nm (Middle)/ 24 nm (Long)

3.5.4 Measuring Equipment List:
 See Attachment D [List of Test/Measuring Equipment].

3.5.5 Test settings:

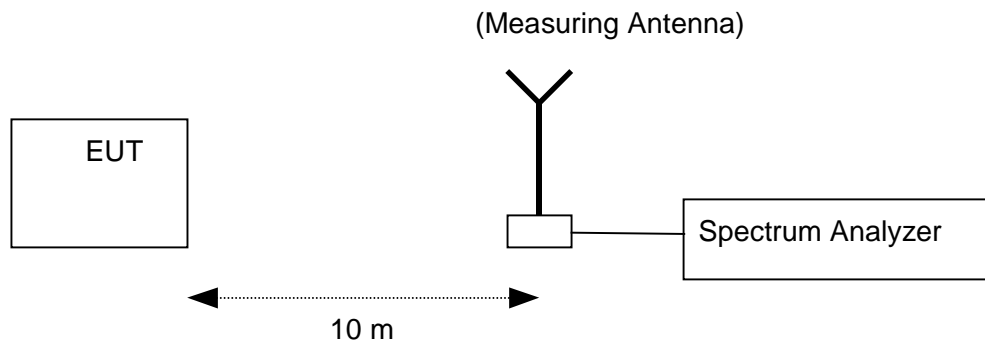

3.5.6 Field Strength Limits:

(a) Frequency Range (FCC Rule § 2.1057(1)) : 10 kHz - 4GHz

(b) Emission Limits (FCC Rule § 80.211) :

Frequency removed from the assigned frequency	Frequency (MHz)	Emission attenuation (mean power, dB)
50 - 100 % (of the authorized bandwidth)	9,310 - 9,360	At least 25
	9,460 - 9,510	
100 - 250 %	9,160 - 9,310	At least 35
	9,510 - 9,660	

Frequency removed from the assigned frequency	Frequency (MHz)	Emission attenuation (mean power, dB)
more than 250 %	0.01 - 9,160 9,660 - 40,000	At least $43 + 10 \log_{10}$ (mean power in watts)

Note : (1) Assigned frequency (center frequency) = 9410 MHz

(2) Authorized bandwidth = 100 MHz

3.5.7 Test Results:

As shown in Attachment B, the field strengths of spurious radiation generated by EUT are found lower than the specified limits.

3.6 Frequency Stability (FCC Rule § 2.1055)

3.6.1 Setup for Measurement

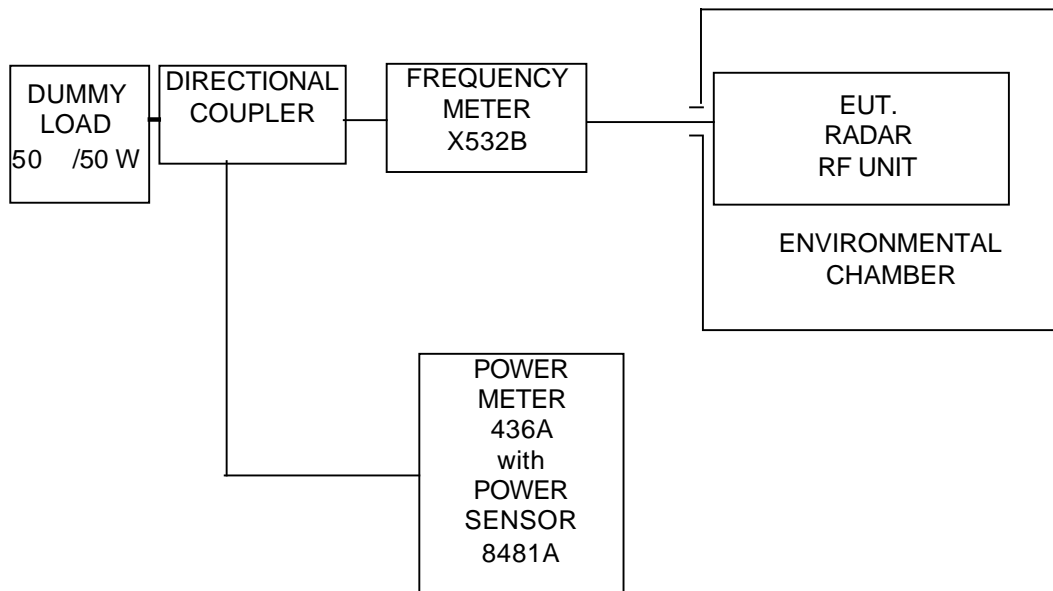

Fig. 3.6.1

3.6.2 Test Conditions:

- 1) Radar Range settings : 0.125 nm (Short)/2 nm (Middle)/ 24 nm (Long)
- 2) Ambient Temperature settings: - 20 to + 50° C (10 °C step)
- 3) Power Supply Voltage settings: 85 /115 % of nominal voltage (20.4 to 27.6 VDC)

3.6.3 Measuring Equipment List:

See Attachment D [List of Test/Measuring Equipment].

3.6.4 Frequency Tolerance Limits:

"The frequency at which maximum emission occurs must be within the authorized bandwidth and must not be closer than $1.5/T$ MHz to the upper and lower limits of the authorized bandwidth, where "T" is the pulse duration in microseconds. "

(FCC Rule § 80.209 (b))

1) Center frequency (f_0): 9410 MHz

2) Authorized bandwidth ($f(\text{AUBW})$): 100 MHz

"Upper limit frequency of the authorized band", $f(\text{UAUBW}) = f_0 + f(\text{AUBW})/2 = 9460$ MHz

"Lower limit frequency of the authorized band", $f(\text{LAUBW}) = f_0 - f(\text{AUBW})/2 = 9360$ MHz

3) Assignable frequency bandwidth : 200 MHz (between 9300 MHz and 9500 MHz)

(FCC Rule § 80.375 (d)-(1))

"Upper limit frequency of the assignable band", $f(\text{UASB}) = 9500$ MHz

"Lower limit frequency of the assignable band", $f(\text{LASB}) = 9300$ MHz

4) Guard Band ($f(1.5/T)$) :

Pulselength	Short	Middle	Long
Range Scale (nm)	0.125	2	24
Pulselength (μsec)	0.08	0.30	0.80
Guard Band $f(1.5/T)$ (MHz)	18.75	5.00	1.88

3.6.5 Test Results:

Shown on Fig. 3.6.2.

(1) "Upper Tolerance Frequency measured (at -20°C)", $f(\text{U}) = 9422.2$ MHz

(2) "Lower Tolerance Frequency measured (at $+50^\circ\text{C}$)", $f(\text{L}) = 9403.0$ MHz

(3)-(a)

$f(\text{U}) + \text{max. } f(1.5/T) = 9440.95$ MHz < $f(\text{UAUBW}) = 9460$ MHz $f(\text{UASB}) = 9500$ MHz

(3) - (b)

$f(\text{L}) - \text{max. } f(1.5/T) = 9384.25$ MHz > $f(\text{LAUBW}) = 9360$ MHz $f(\text{LASB}) = 9300$ MHz

So, both are found within the specified limits.

FREQUENCY STABILITY WITH VARIATION OF PRIMARY SUPPLY VOLTAGE:

The built-in voltage regulator allows no frequency variation against variations of $\pm 15\%$ of nominal power supply voltage (20.4 to 27.6 VDC for nominal 24 VDC).

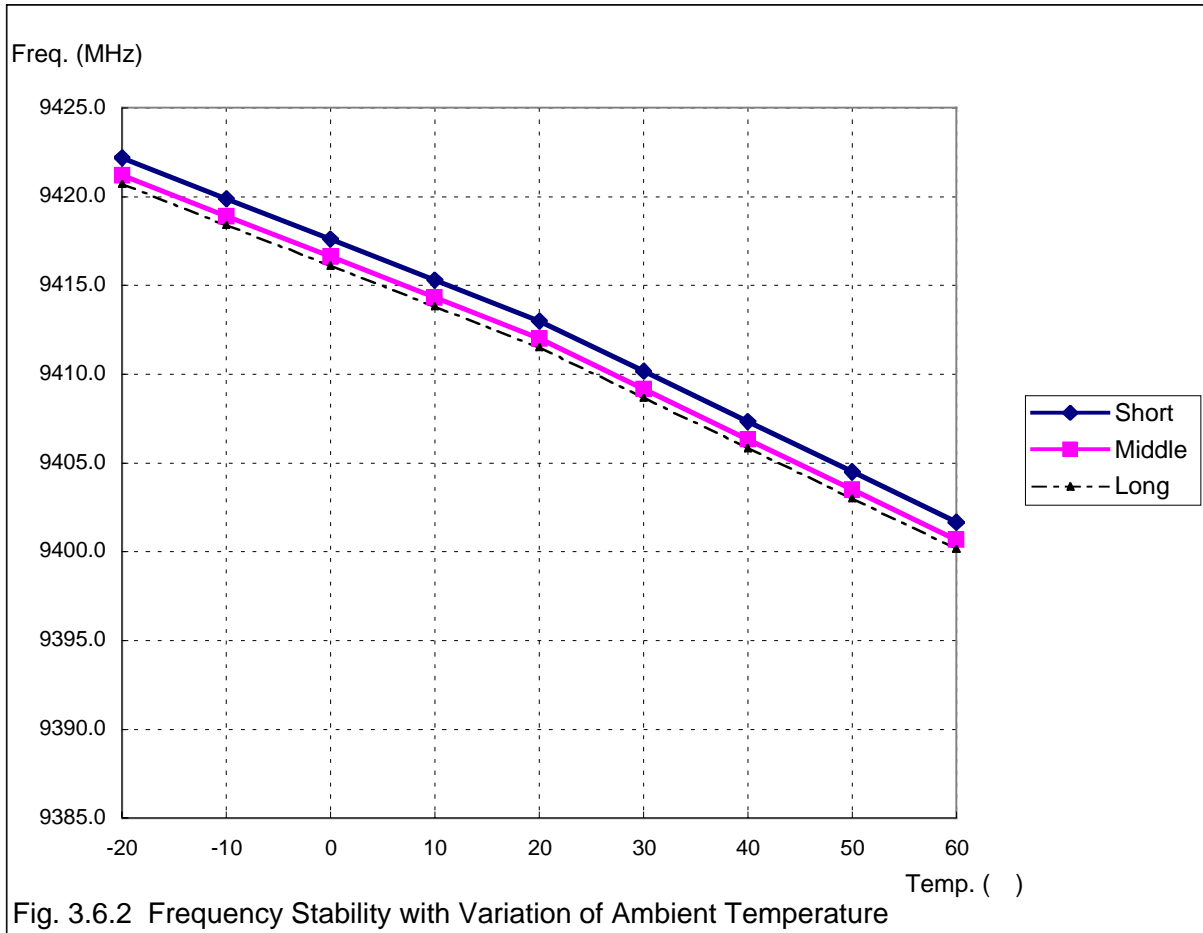

3.7 Suppression of Interference Aboard Ships (FCC Rule § 80.217)**3.7.1 Measuring Antenna Characteristics at Representative Frequencies:**

Whip antennas are used to determine the level of interference caused by the radar to shipboard receivers. These antennas have the following characteristics (refer to impedance charts attached):

Length	Test Frequency (Hz)	Impedance (W)	q	R (W)	C or L
6 m	500.5 k	1 k	-90°	0	80 pF
6 m	1.992 M	1.25 k	-86°	87.2	64 pF
6 m	10.00204 M	158		109	140 pF
4 m	27.5 M	95		83.5	128 pF
5/8 λ	150 M	116.5		105.5	52.5 nH
1/4 λ	450 M	70.5		34.5	5.68 pF

3.7.2 Test Site: Rooftop of 6-story building,
Furuno Electric Company, Ltd.
Ashihara-cho 9-52, Nishinomiya-city, 662-8580 JAPAN

3.7.3 Measuring Instrument List:

See Attachment D [List of Test/Measuring Equipment].

(Instruments for measuring antenna characteristics are listed below.)

- (1) Network Analyzer, HP 8753C
- (2) Spectrum Analyzer, ADVANTEST TR4172
- (3) Spectrum Analyzer, HP 8566B
- (4) Antennas,
for 14 k - 10 MHz, 6 m whip
for 10 - 30 MHz, 4 m whip
for 30 - 300 MHz, VHF whip
for 300 - 1000 MHz, UHF whip

3.7.4 Test Results:

Interference levels to the respective antenna were measured at 2 m from the radar which was put in OFF and TRANSMIT conditions, and found within the specified limits.

3.7.4.1 Harmful Interference to Receiver (FCC Rule § 80.217 (a))

Limits: for 14 - 490 kHz, 5 mV/m
for 490 kHz - 1 GHz, 1 mV/m

Results: There is no spurious component which is deemed harmful interference. (Test data are shown in Attachment C.)

3.7.4.2 Electromagnetic Field (FCC Rule § 80.217 (b) - 1)

Limits: for below 30 MHz, 0.1 mV/m at 1 nm (-20 dBmV/m)
for 30 to 100 MHz, 0.3 mV/m at 1 nm (-10.5 dBmV/m)
for 100 to 300 MHz, 1.0 mV/m at 1 nm (0 dBmV/m)
for over 300 MHz, 3.0 mV/m at 1 nm (9.5 dBmV/m)

Results: Interference was measured with the antenna located 2 m from the radar and converted to levels at 1 nm. There is no spurious component exceeding the limits.
(Test data are shown in Attachment C.)

3.7.4.3 Power Input to an Artificial Antenna (FCC Rule § 80.217 (b) - 2)

Limits: for below 30 MHz, 400 mW
for 30 to 100 MHz, 4,000 mW
for 100 to 300 MHz, 40,000 mW
for over 300 MHz, 400,000 mW

Results: There is no spurious component exceeding the limits.
(Test data are shown in Attachment C.)

MEASUREMENT OF IMPEDANCE OF TEST ANTENNAS

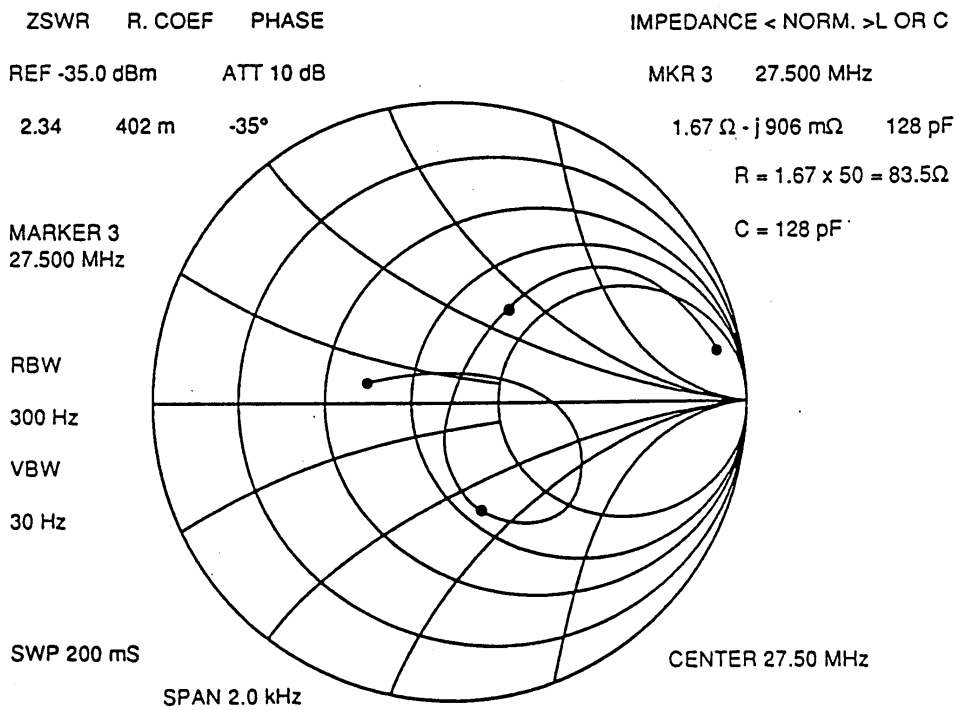
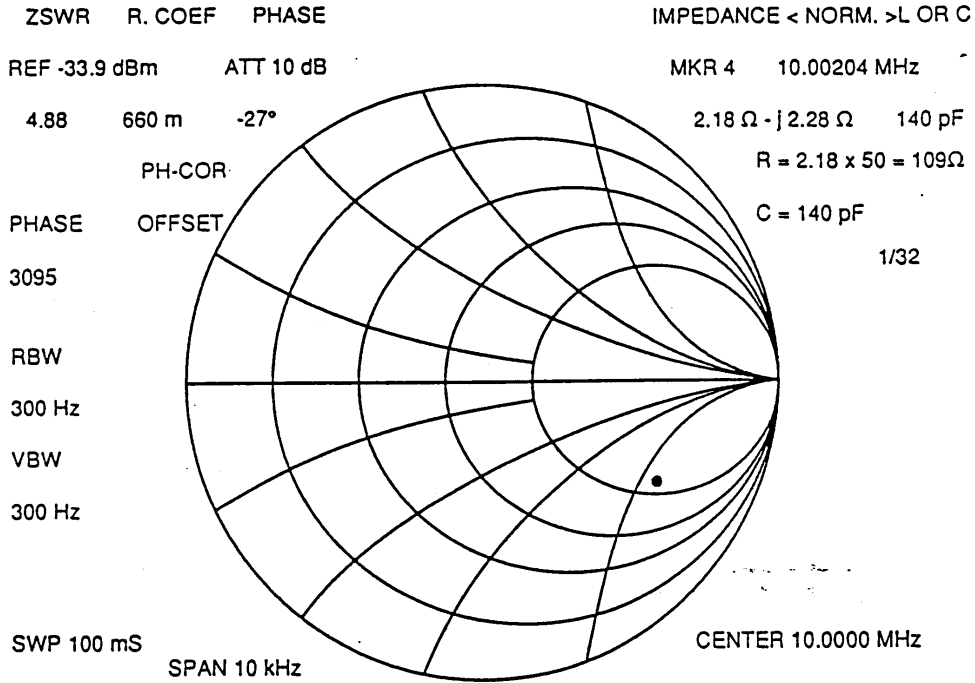

MEASUREMENT OF IMPEDANCE OF TEST ANTENNAS

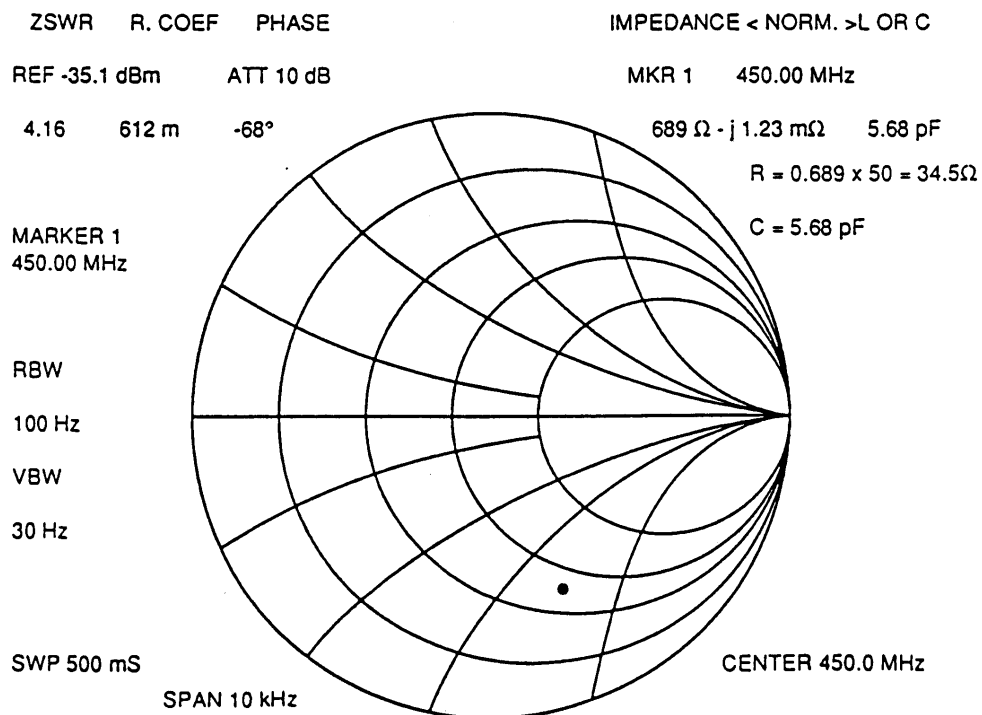
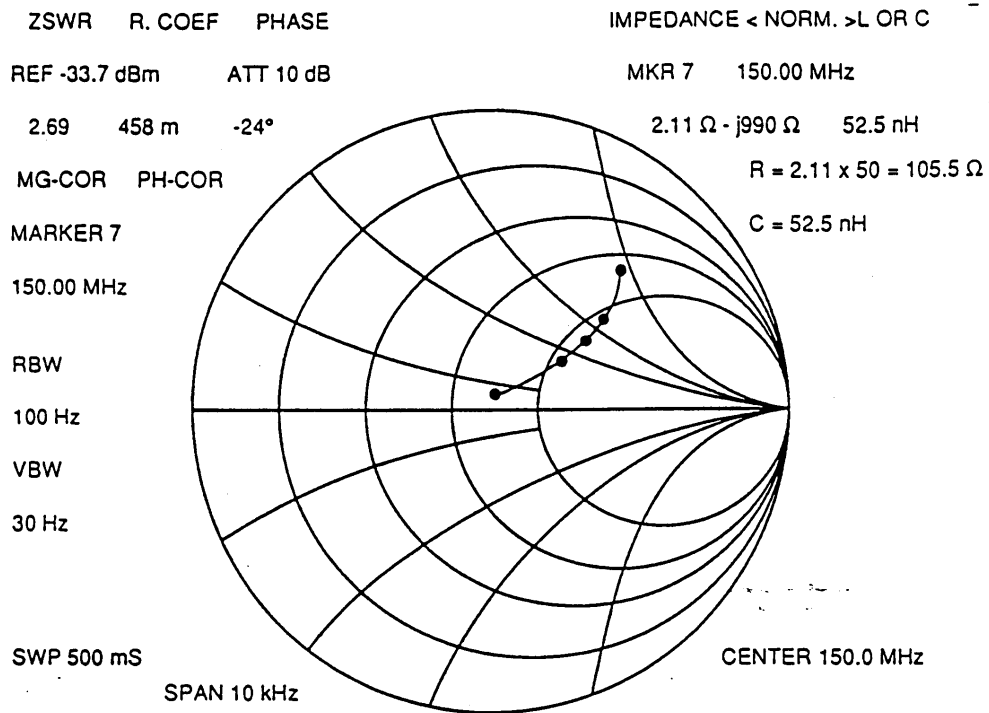

4 Photographs to Reveal Equipment Construction and Layout (FCC Rule § 2.1033)

(See Attachment E Photos of the Equipment Under Test (EUT))

5 Description of Circuitry and Devices (FCC Rules § 2.1033)**5.1 Function of Each Semiconductor or Active Device****ANTENNA UNIT**

TRANSCEIVER MODULE (RTR-075)

MD PCB 03P9270

CR802:	Voltage Regulator
CR803 & CR834:	Power Switch Control
CR804:	Over Current Protection
CR805 & CR835	Snubber Diode
CR831 & CR832:	Rectifier
CR836-CR838:	Rectifier
CR851:	Pulse Width Select
CR853:	Reverse Voltage Protection
CR855:	Detector (Magnetron Current)
CR856 & CR857:	Reverse Voltage Protection
CR858 & CR859:	Rise-up Voltage Control
Q801:	9V Regulator
Q802:	Power Switch Control
Q803:	45 kHz PWM Inverter and Output MOS FET
Q804:	Current Detector
Q805:	Pulse Amplifier
Q831:	Power Switch Control
Q832:	45 kHz Inverter and Output MOS FET
Q851 & Q852:	Pulse Width Select
Q857:	Pulse Amplifier
Q858 & Q859:	Pulse Width Select
Q860:	TX Trigger Pulse Voltage Buffer
Q861:	Pulse Amplifier
U801:	45 kHz PWM Inverter Control
U802 & U803:	Voltage Detector
U804:	DC Voltage Regulator
U805:	45 kHz Inverter Control
U851:	Dual Monostable Multivibrator
U852:	Pulse Width Select
U853 & U854:	Pulse Amplifier

IF PCB 03P9329

CR1 & CR2:	Filter Bandwidth Controlling
CR4:	Video Signal Combining
CR5:	Temperature Compensating
CR6:	Limiter
CR7:	Detector
CR8:	Temperature Compensating
CR9:	Limiter
CR11:	Voltage Limiter
CR12:	MBS Pulse Width Control
CR13:	Limiter
Q1 to Q3:	FET Switch
Q4 & Q5:	Tuning Amplifier
Q6 & Q7:	IF Amplifier
U1:	IF Amplifier
U2:	Buffer
U3:	Comparator
U4:	IF Amplifier
U5:	Multiplexer
U6:	Tuning Amplifier
U7:	Comparator
U8 to U10:	Logic
U16:	Logic

INT PCB 03P9328

CR1 to CR4:	Transient Suppression
Q1 to Q8:	Transistor Switch
U1 to U3:	Logic
U4:	PLL
U5 & U6:	Logic
U7 & U8:	Voltage Regulator

Chassis-mounted parts

B801:	Scanner Motor
U801:	Circulator & MIC
V801:	Magnetron
W801:	Lead-switch

5.2 Description of the circuits employed for suppression of spurious radiation, for limiting or shaping the control pulse, and for limiting or controlling power**ANTENNA UNIT**

TRANSCEIVER MODULE (RTR-075)

Modulator/Block PCB 03P9270

The primary function of the modulator is to produce narrow high tension pulses to drive the magnetron. To produce such pulses, the modulator block incorporates a modulator trigger circuit, a modulating pulse generator and a booster pulse transformer.

The modulator trigger circuit is composed of U851 and associated components. It generates pulses that fire modulator FET Q857. Normally, the circuit is stable with U851 off. The pulse to fire the modulator FET is produced when U851 turns on upon receiving the TX trigger pulse from the display unit. When U851 turns on at the positive-going edge of the TX trigger pulse, it produces a narrow pulse. This narrow pulse is boosted by pulse transformer T851 by the ratio 1:9. The resultant pulse, its level being 2.2 kV, is provided to oscillate the magnetron.

CR856 and CR857 absorb the ringing in the secondary side of T851 while C862 decouples the pulse energy that is liable to occur across the magnetron heater when T851's secondary windings are unbalanced or the load is asymmetric.

Also incorporated in the PCB 03P9270 are the TX HV circuit and magnetron heater power supply circuit. The TX HV circuit provides a high tension of about 300 V to the pulse forming network through CR837,CR838. A DC voltage of 8.0 V is supplied to the magnetron heater through CR836.

Duplexer and Frequency Converter

Since this radar uses a patch array antenna for transmission and reception, an efficient device is required for switching the transmission and receiver. This radar employs circulator U801 (Composed of the circulator and the MIC) for this purpose. It is a passive directional coupler with three ports.

The microwave energy produced by the magnetron enters the circulator from port RF1. It is fed

to port RF2 with little loss of energy; port MIC-INPUT at this is isolated. In the same manner, the received signal entering into RF2 is transferred to port MIC-INPUT, isolating port RF1. This operation of the circulator protects the receiver during transmission and minimizes the loss of the received signal.

A diode limiter, made up of a pair of PIN diodes, is incorporated in the first stage of the MIC (microwave IC). It is a passive switching device which allows the low-level RF signal to pass through and prohibits relatively strong microwave energy, such as the leak from the circulator during each TX cycle or the TX pulses received directly from other radars operating in the proximity, to enter the sensitive receiver circuit.

When a low-level signal is received, the PIN diodes remain in the cutoff state, and the limiter's input impedance matches the characteristic impedance of the receiver allowing the signal to be delivered to the frequency converter of the MIC. When strong microwave energy is received, the PIN diodes are put in the conductive state (or short-circuited) causing the input energy to be attenuated. The strong input is further reduced to about 150 mW by the limiter diode.

The MIC converts 9 GHz RF signal into an intermediate frequency of 60 MHz. It is achieved by mixing the received signal with the local oscillator signal in the frequency converter of the MIC. The built-in local oscillator oscillates at a frequency 60 MHz higher than the magnetron frequency of 9410 MHz.

IF Amplifier PCB 03P9329

The converted 60 MHz IF signal from MIC is amplified in the IF amplifier block. The signal detected at the final stage is delivered to the display unit video amplifier.

The 60 MHz IF signal is divided into the tuning block and the amplifier block through C39 and C83/C89.

In the tuning block, IF signal is amplified at Q4 and Q5, and then detected at CR7. Its detected voltage is amplified and buffered by U6. Finally the output voltage is used for the tuning indicator and the tuning control.

In the amplifier block, the signal applied to the base of Q7 is amplified in cascade by Q6 and Q7, and sent to the bandpass selector circuits of CR1 to CR2.

The IF amplifier operates in narrow or wide bandwidth mode depending on the settings of the RANGE switch. For short or middle ranges, a wide bandwidth (30 MHz) is selected. On the

contrary, a narrow bandwidth (3 MHz) is selected for long ranges.

Q1, Q2 and Q3 are the attenuator switches for the MBS (Main Bang Suppression) control. The signal amplified, band-selected and MBS-switched is fed to the detector/broadband-amplifier U1. The output of U1 and U4 (Log. amp.) is coupled to the video amplifier U2.

6 Operator's Manual Incl. Circuit Diagrams (FCC Rule § 2.1033)

(See separate covers)

Attachment A

[TEST DATA for Clause 3.4. SPURIOUS EMISSIONS AT ANTENNA TERMINALS]

1. Spurious emissions for 0.125 nm Range:

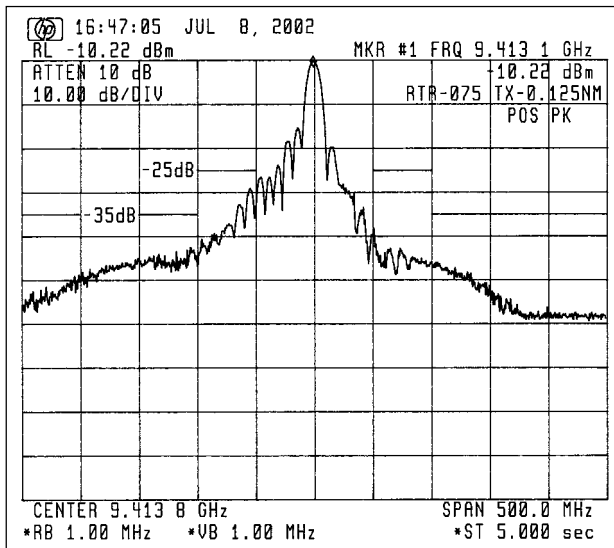

Ref. level: -10.22 dBm

Emission limitations:

- (a) 25 dB for 50 to 100 % of the authorized BW (100 MHz)
- (b) 35 dB for 100 to 250 % of the authorized BW (100 MHz)

Fig. 1.1 Without Filter

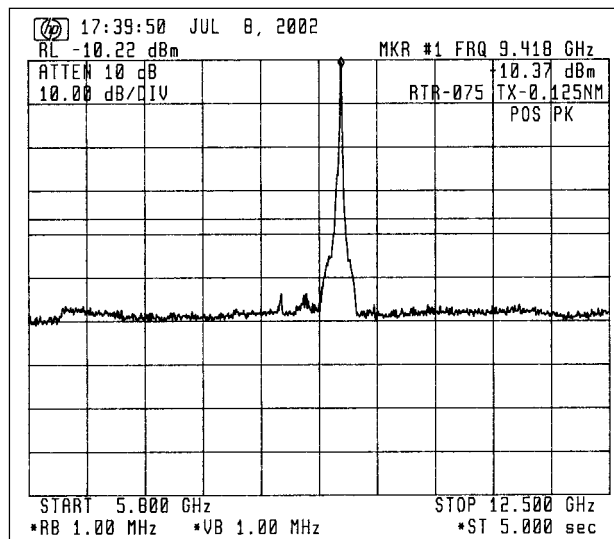

Emission limitations:

- (c) $43 + 10 \log P_m = 36.32 \text{ dB}$ for more than 250 % of the authorized BW (100 MHz)

Fig. 1.2 Without Filter

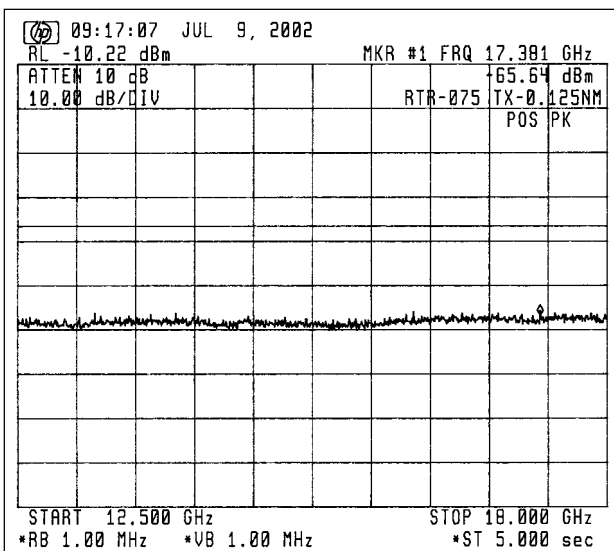

Emission limitations:

- (c) $43 + 10 \log P_m = 36.32 \text{ dB}$ for more than 250 % of the authorized BW (100 MHz)

Fig. 1.3 With Filter No. 2

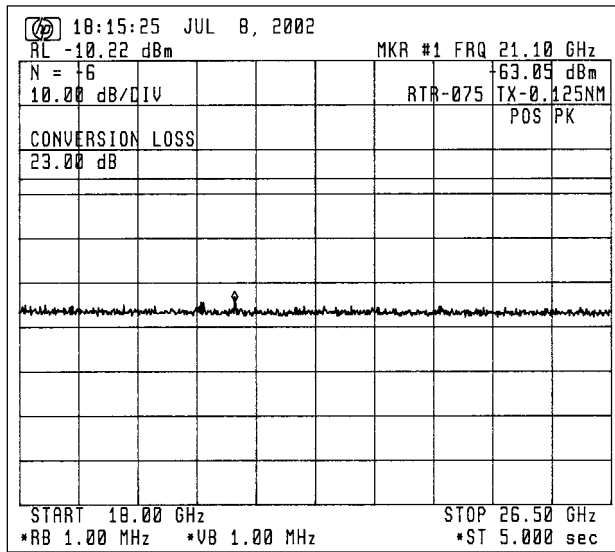

Emission limitations:

(c) $43 + 10 \log P_m = 36.32 \text{ dB}$
for more than 250 % of
the authorized BW (100 MHz)

Fig. 1.4 With Filter No. 2

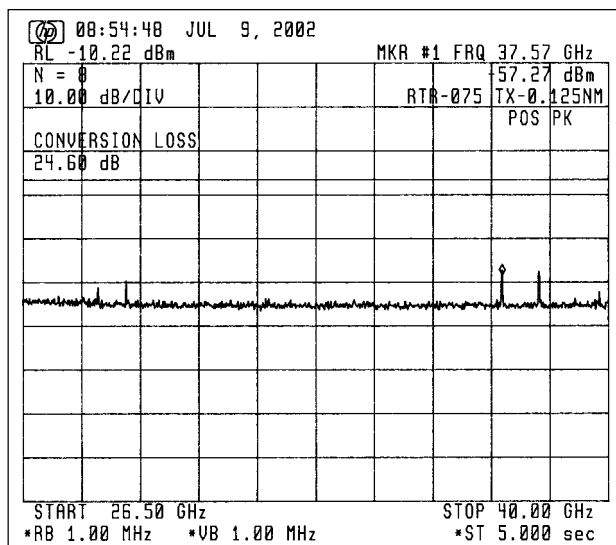

Emission limitations:

(c) $43 + 10 \log P_m = 36.32 \text{ dB}$
for more than 250 % of
the authorized BW (100 MHz)

Fig. 1.5 With Filter No. 2

2. Spurious emissions for 2 nm Range:

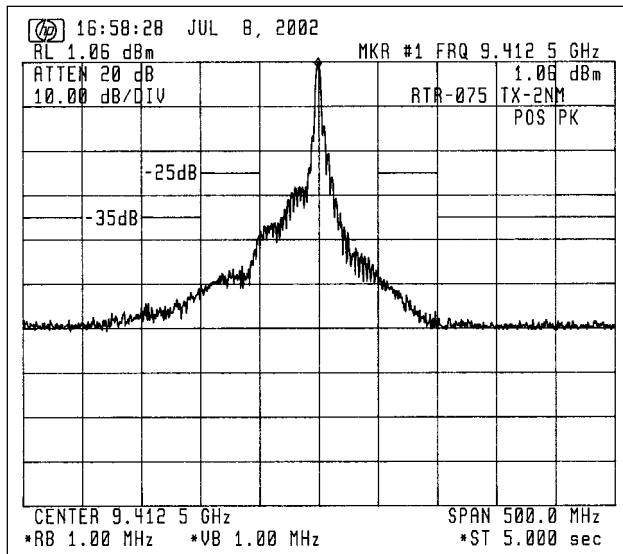

Ref. level: 1.06 dBm

Emission limitations:

- ← (a) 25 dB for 50 to 100 % of the authorized BW (100 MHz)
- ← (b) 35 dB for 100 to 250 % of the authorized BW (100 MHz)

Fig. 2.1 Without Filter

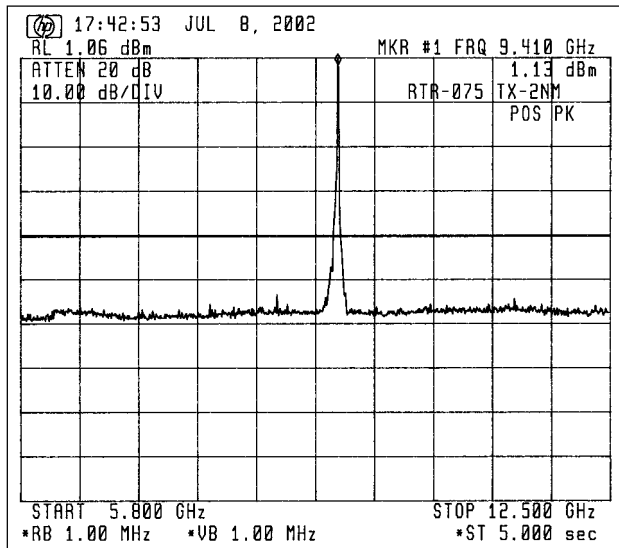

Emission limitations:

- ← (c) $43 + 10 \log P_m = 39.92 \text{ dB}$ for more than 250 % of the authorized BW (100 MHz)

Fig. 2.2 Without Filter

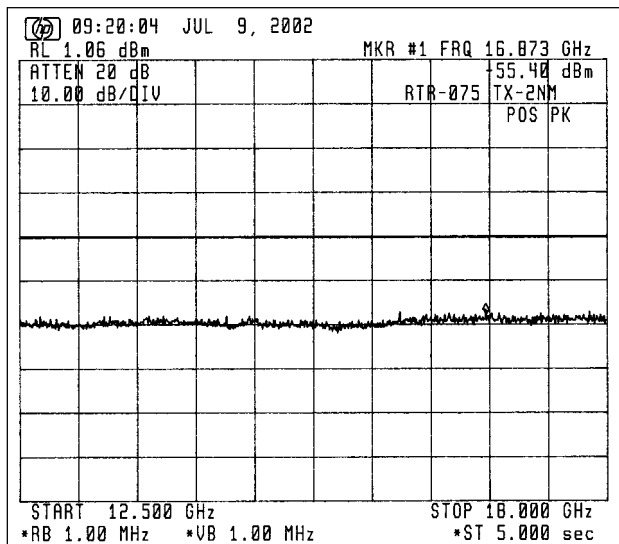

Emission limitations:

- ← (c) $43 + 10 \log P_m = 39.92 \text{ dB}$ for more than 250 % of the authorized BW (100 MHz)

Fig. 2.3 With Filter No. 2

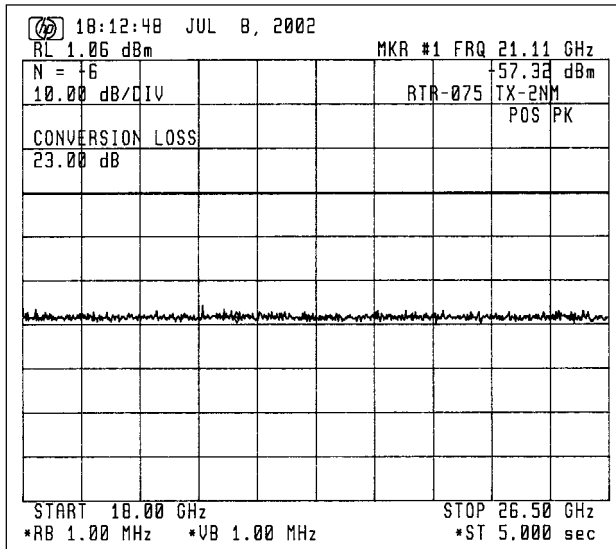

Emission limitations:

- (c) $43 + 10 \log P_m = 39.92 \text{ dB}$
for more than 250 % of
the authorized BW (100 MHz)

Fig. 2.4 With Filter No. 2

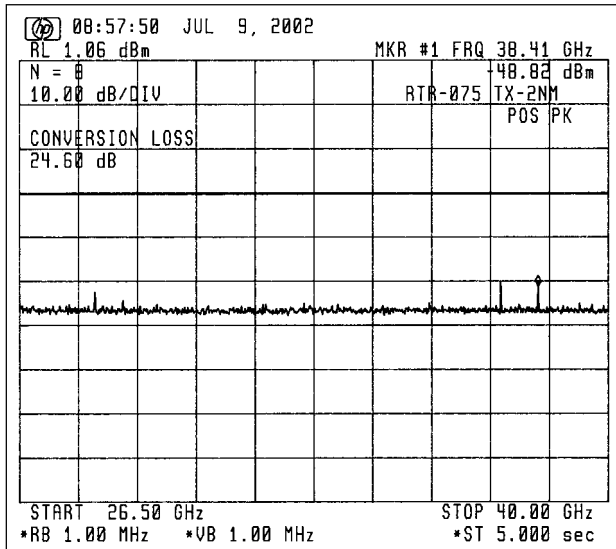

Emission limitations:

- (c) $43 + 10 \log P_m = 39.92 \text{ dB}$
for more than 250 % of
the authorized BW (100 MHz)

Fig. 2.5 With Filter No. 2

3. Spurious emissions for 24 nm Range:

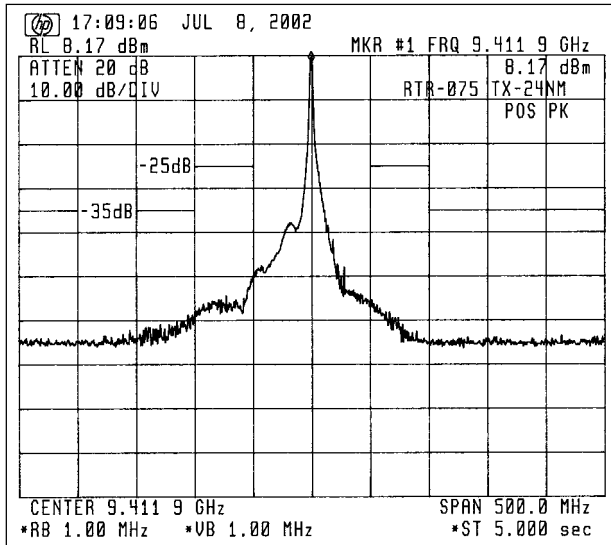

Ref. level: 8.17 dBm

Emission limitations:

- (a) 25 dB for 50 to 100 % of the authorized BW (100 MHz)
- (b) 35 dB for 100 to 250 % of the authorized BW (100 MHz)

Fig. 3.1 Without Filter

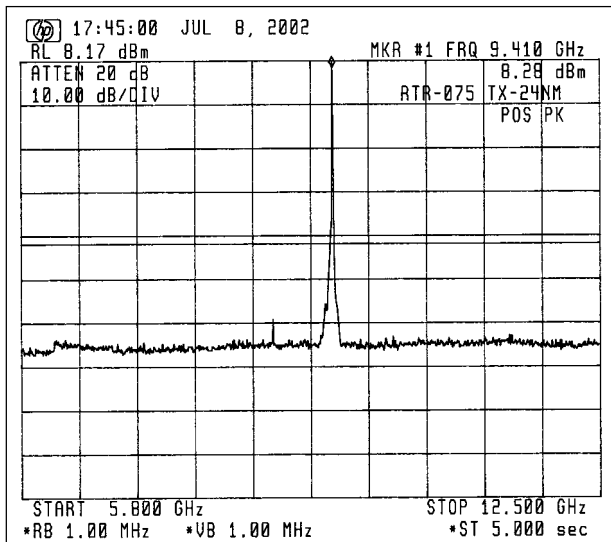

Emission limitations:

- (c) $43 + 10 \log P_m = 41.52$ dB for more than 250 % of the authorized BW (100 MHz)

Fig. 3.2 Without Filter

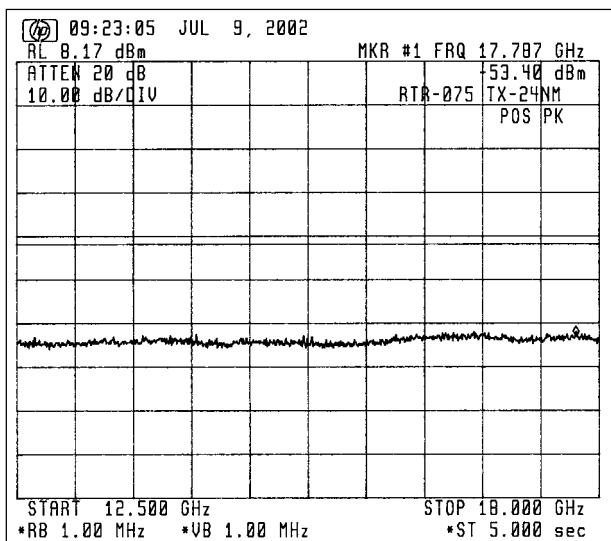

Emission limitations:

- (c) $43 + 10 \log P_m = 41.52$ dB for more than 250 % of the authorized BW (100 MHz)

Fig. 3.3 With Filter No. 2

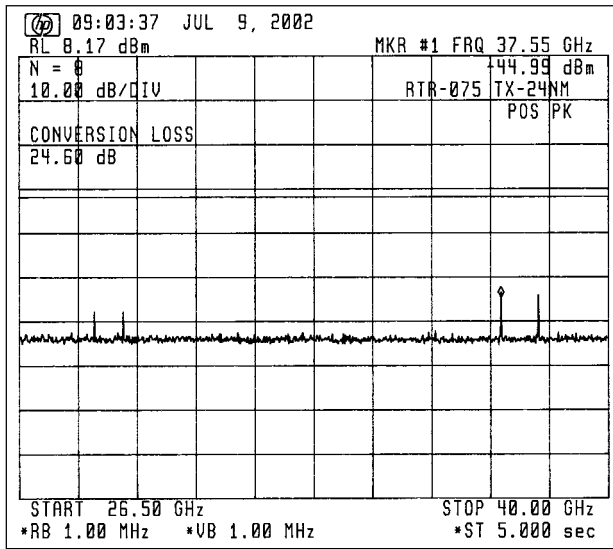

Emission limitations:

- (c) $43 + 10 \log P_m = 41.52 \text{ dB}$
for more than 250 % of
the authorized BW (100 MHz)

Fig. 3.4 With Filter No. 2

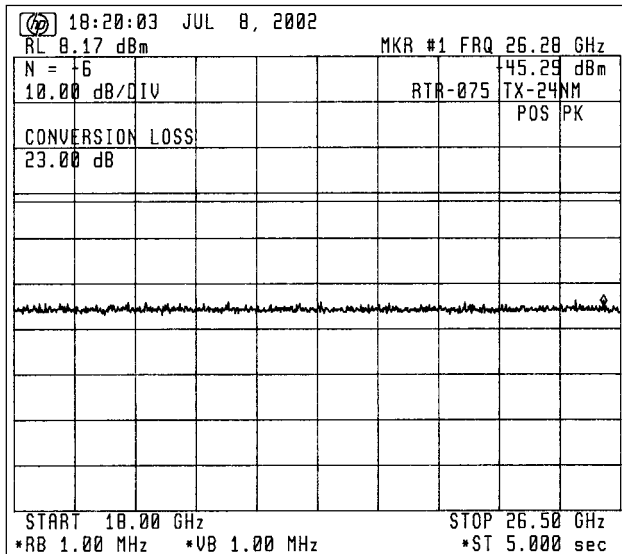

Emission limitations:

- (c) $43 + 10 \log P_m = 41.52 \text{ dB}$
for more than 250 % of
the authorized BW (100 MHz)

Fig. 3.5 With Filter No. 2

Attachment B

TEST DATA for Clause 3.5 FIELD STRENGTH OF SPOURIOUS RADIATION

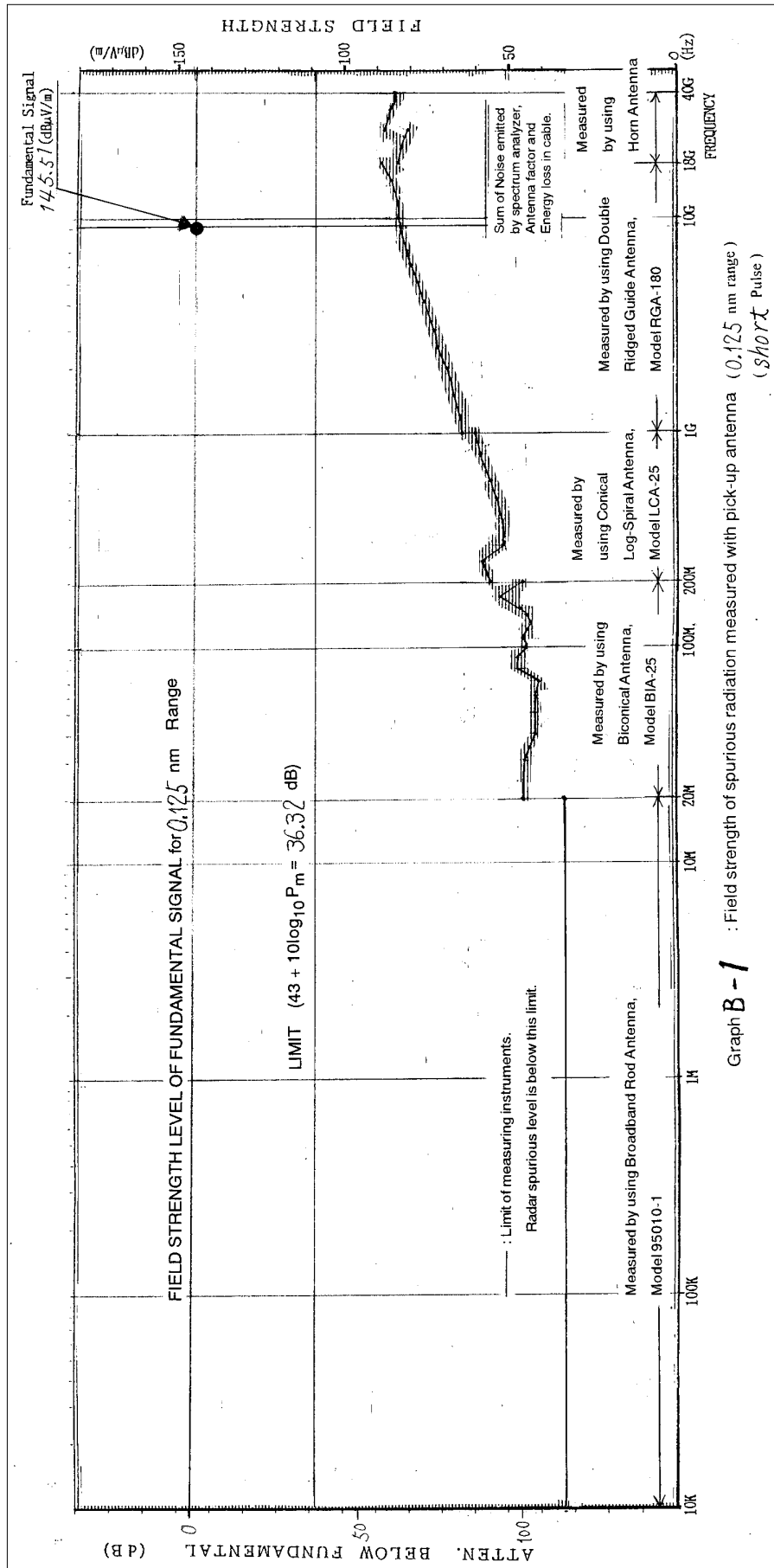

Graph B-1 : Field strength of spurious radiation measured with pick-up antenna (0.125 nm range) (Short Pulse)

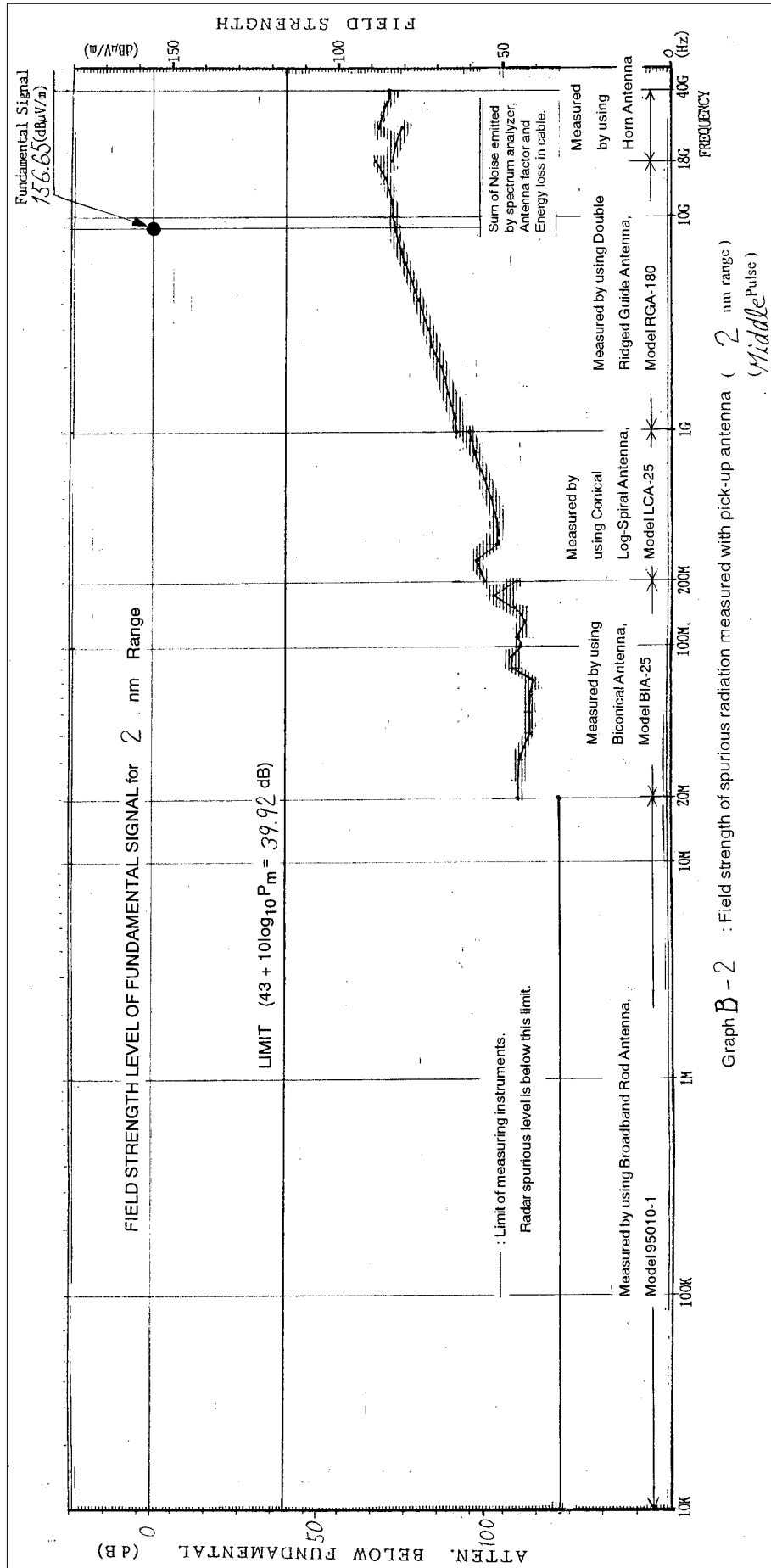

Graph B-2 : Field strength of spurious radiation measured with pick-up antenna (2 nm range)
(Middle Pulse)

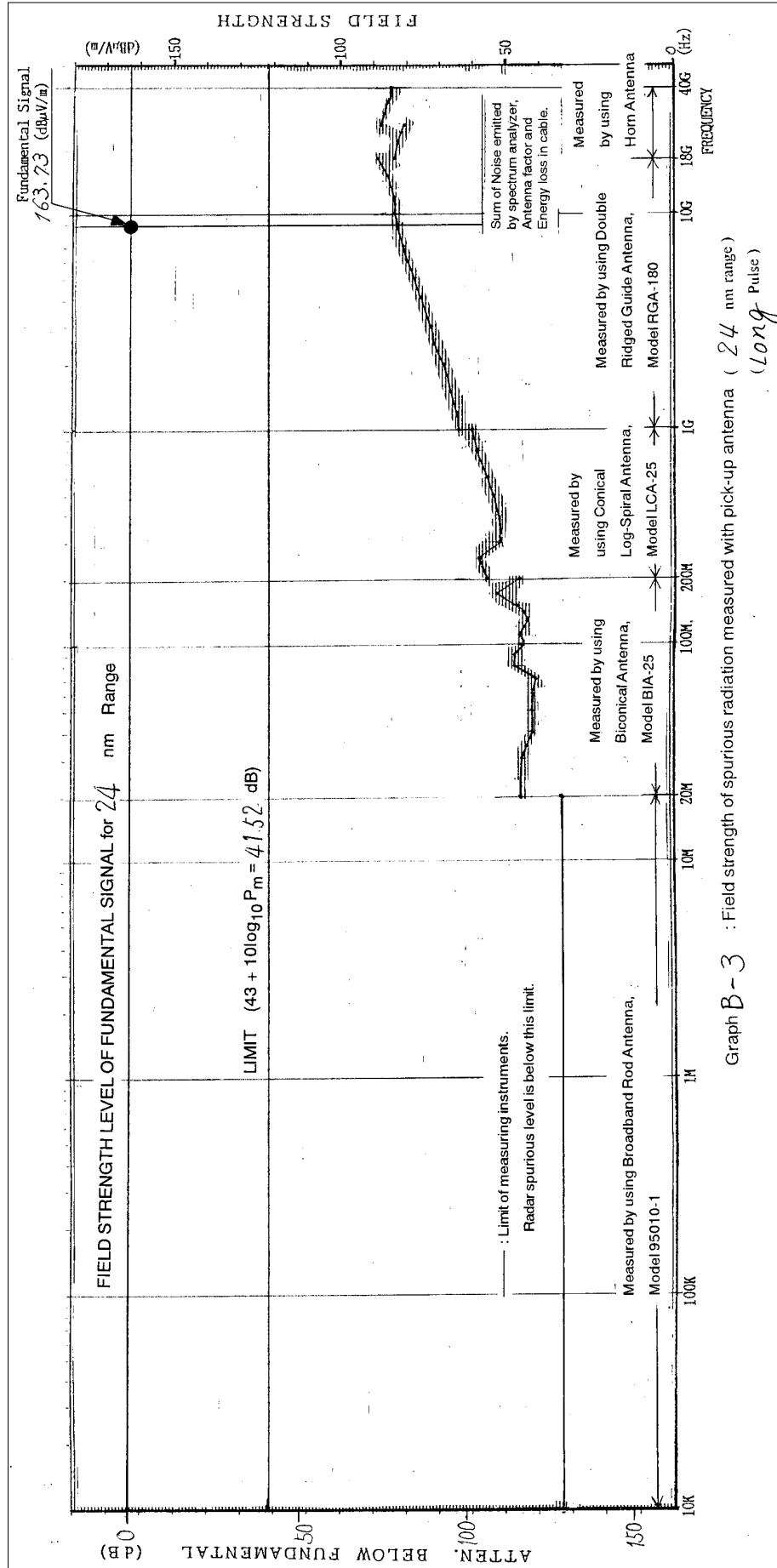

Attachment C

[TEST DATA for Clause 3.7 SUPPRESSION OF INTERFERENCE ABOARD SHIPS]

1. Harmful Interference to Receiver

(Band : 14 kHz - 490 kHz)

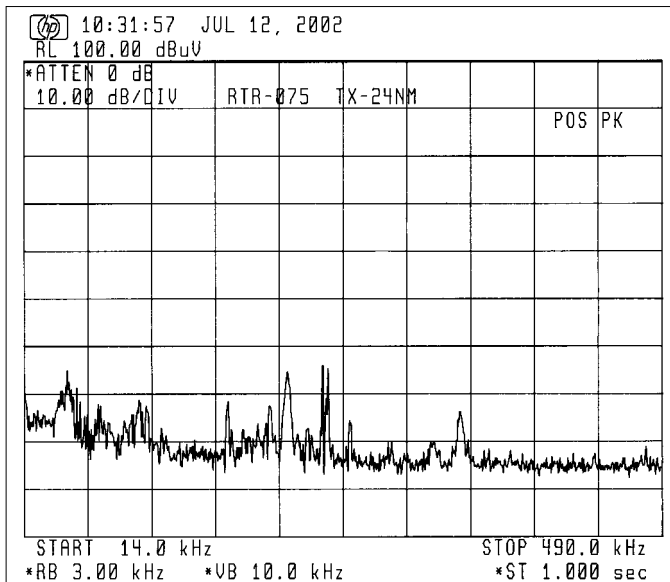
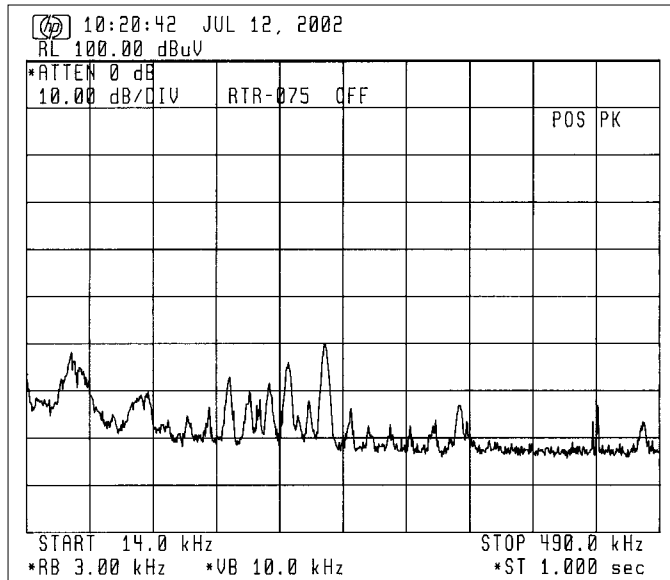

(Band : 490 kHz - 5 MHz)

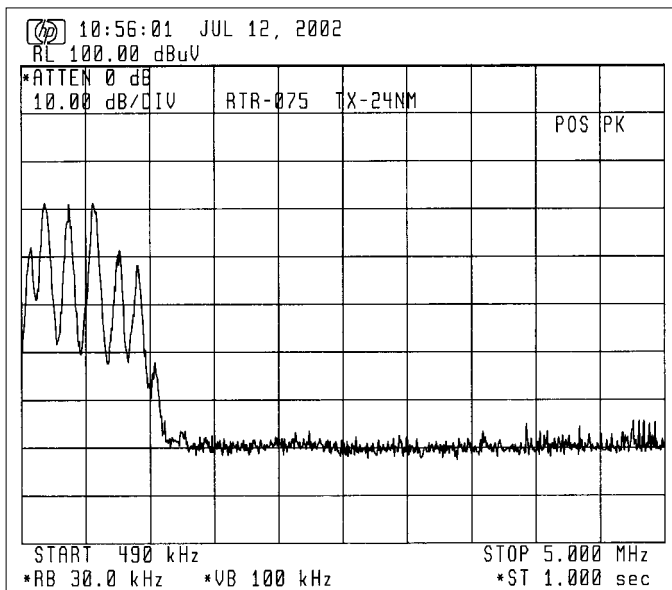
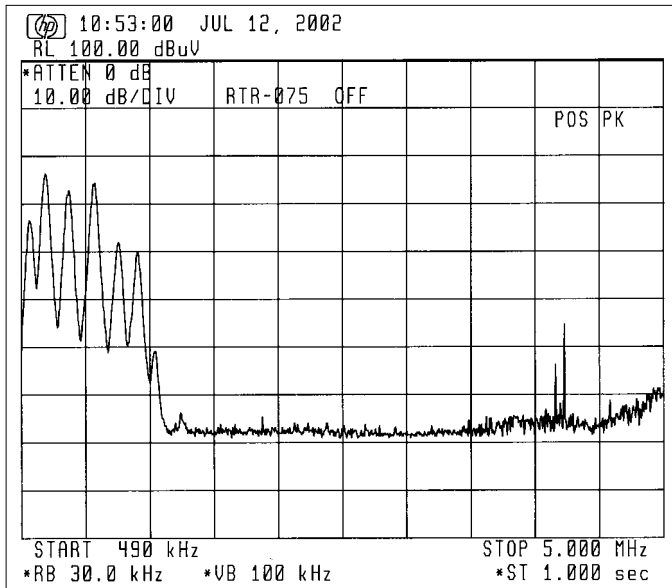

(Band : 5 MHz - 10 MHz)

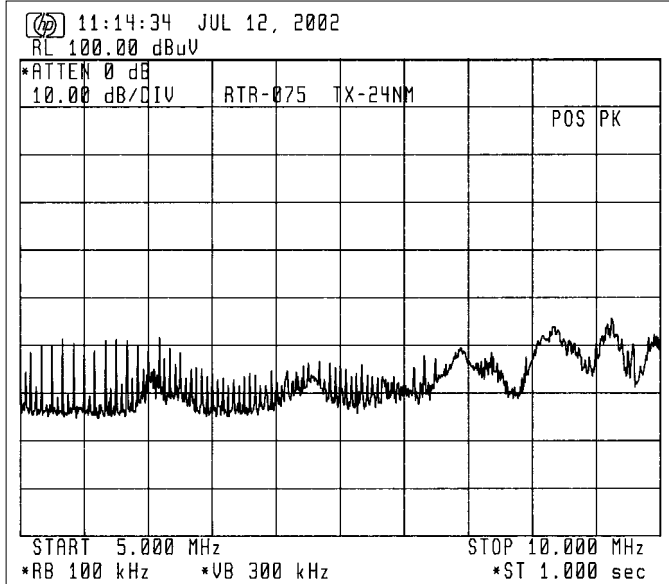
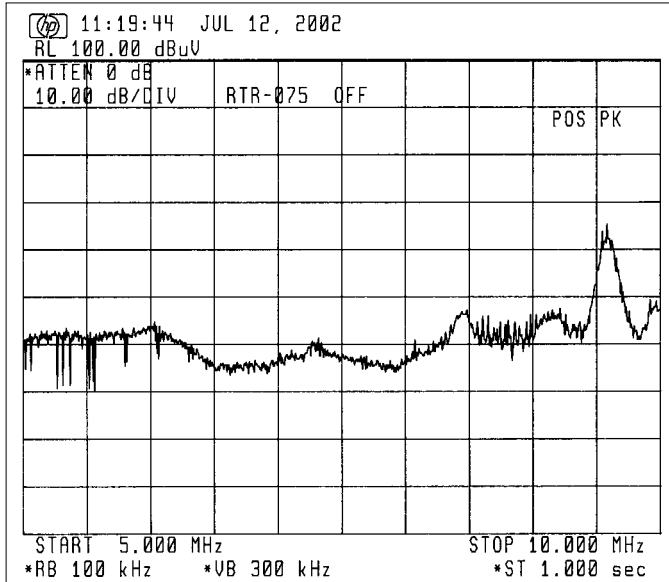

(Band : 30 MHz - 100 MHz)

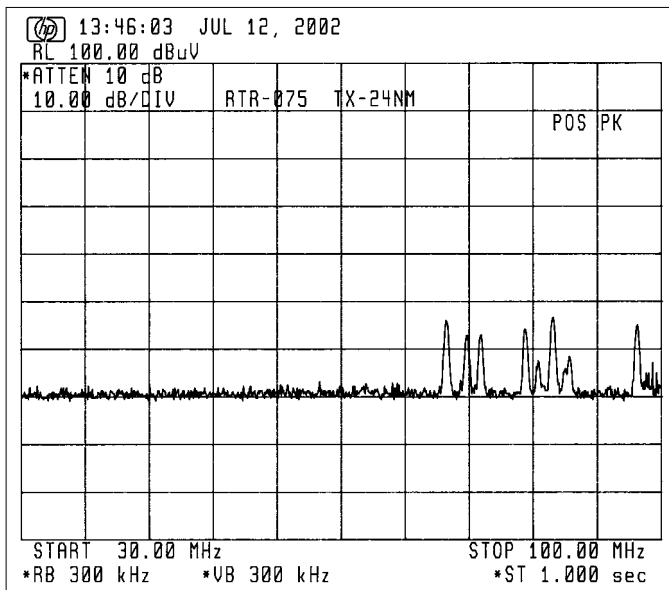
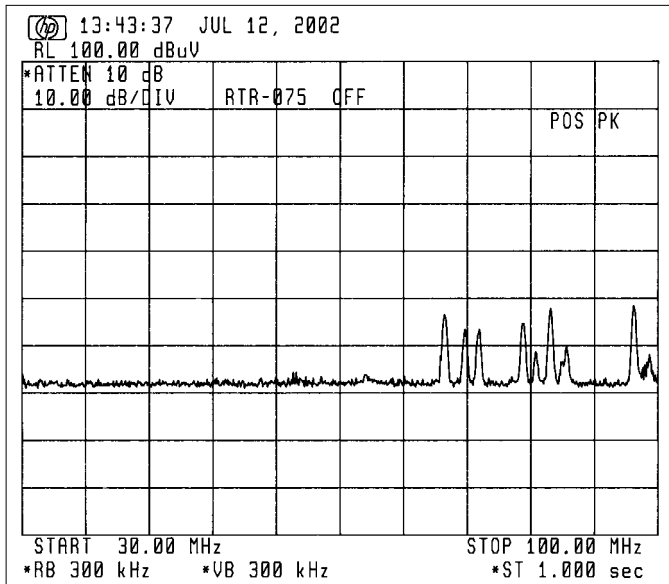

(Band : 100 MHz - 300 MHz)

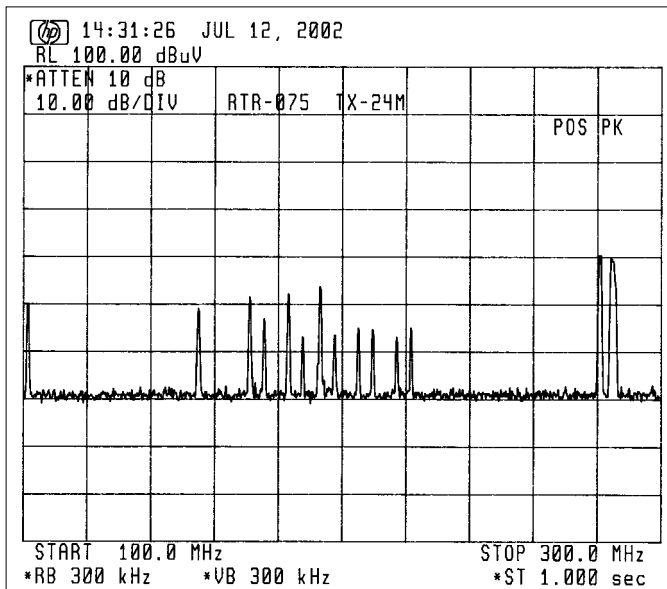
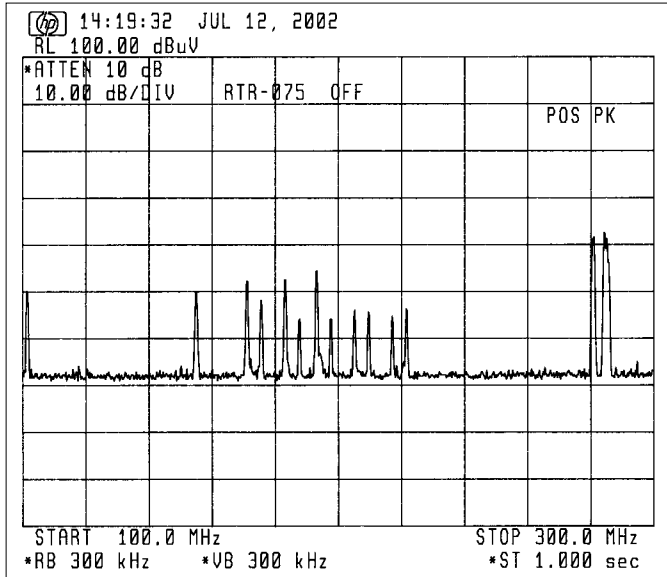

(Band : 300 MHz - 1 GHz)

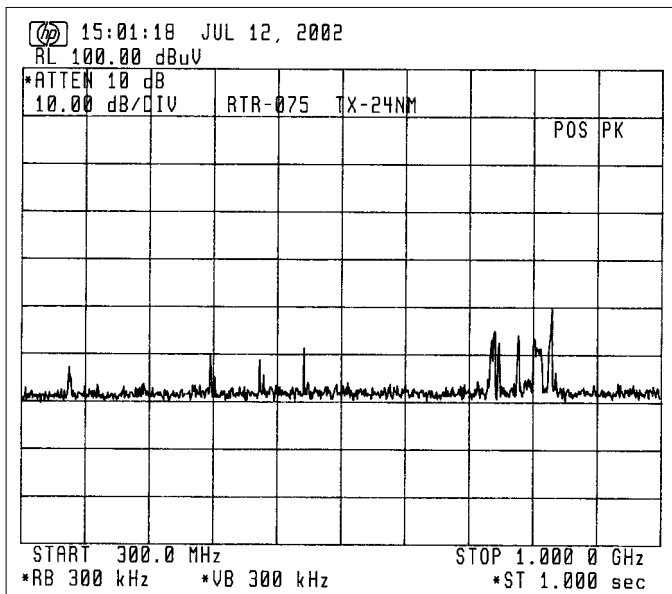
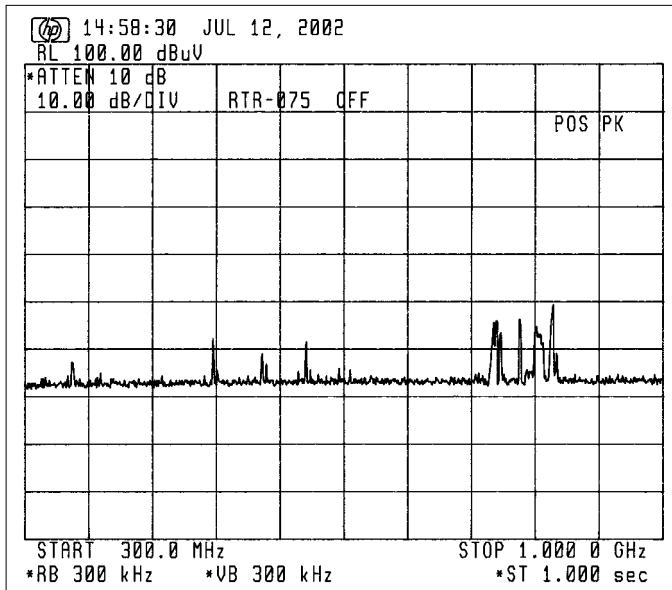

2. Electromagnetic Field

(Band : 14 kHz - 490 kHz, Limit at 1 nm = 0.1 $\mu\text{V}/\text{m}$ = -20 dB $\mu\text{V}/\text{m}$)

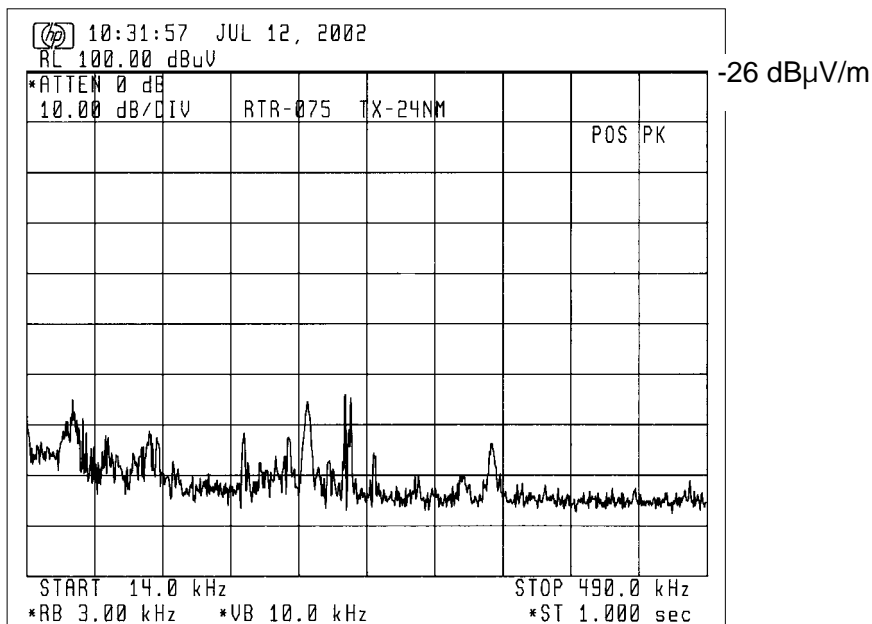
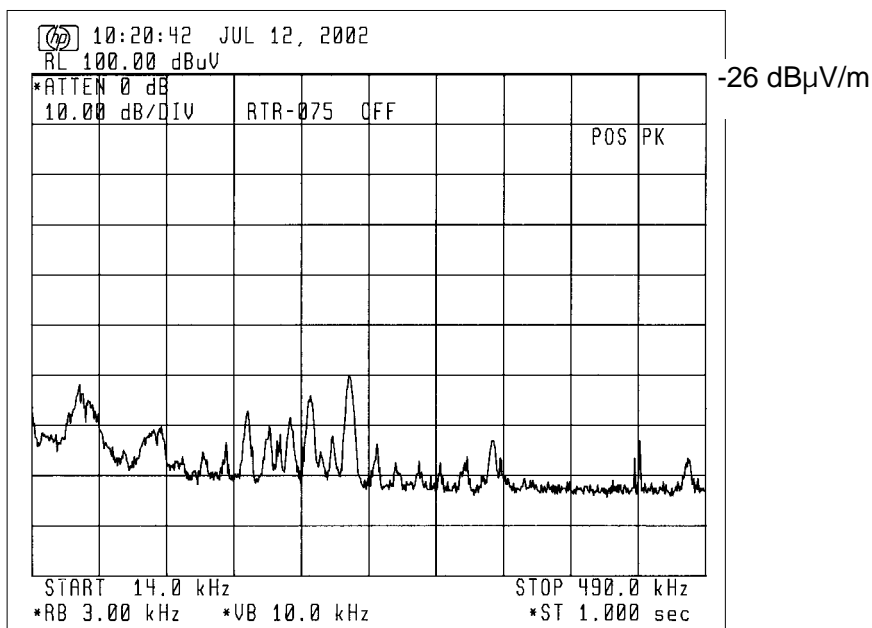

(Band : 490 kHz - 5 MHz, Limit at 1 nm = 0.1 μ V/m = -20 dB μ V/m)

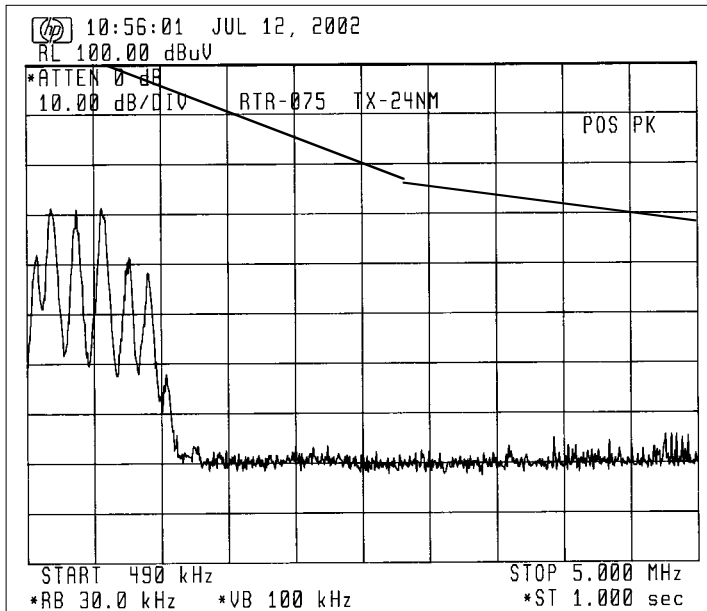
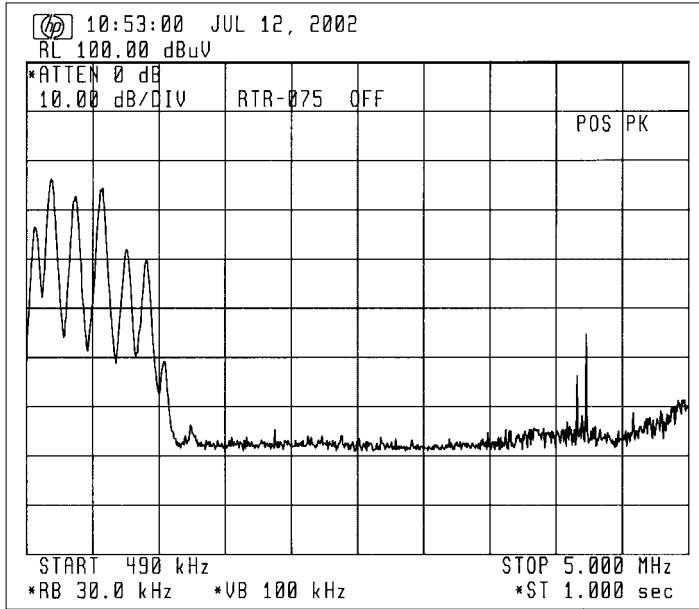

Ref. level (dB μ V/m)
 = 100 - 126 = -26 (at 0.5 MHz)
 = 100 - 96 = 4 (at 3 MHz)
 = 100 - 88 = 12 (at 5 MHz)

-20 dB μ V/m limit line

(Band : 5 MHz - 10 MHz, Limit at 1 nm = 0.1 μ V/m = -20 dB μ V/m)

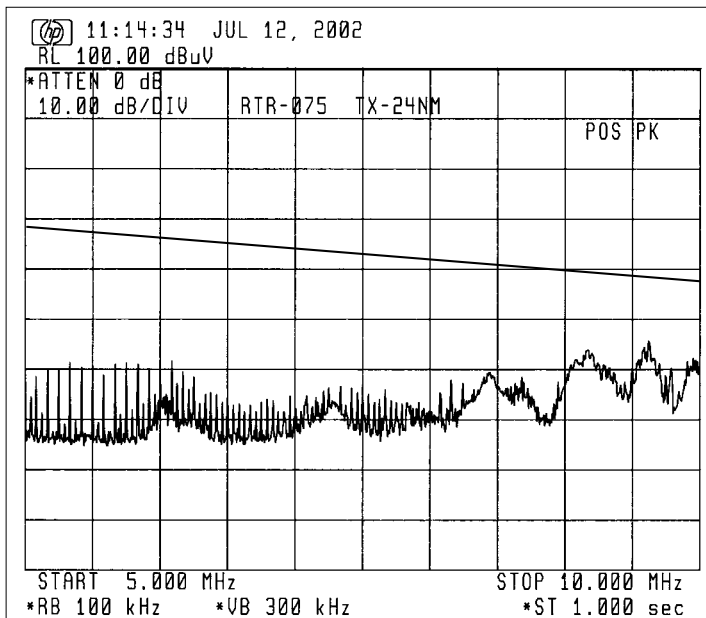
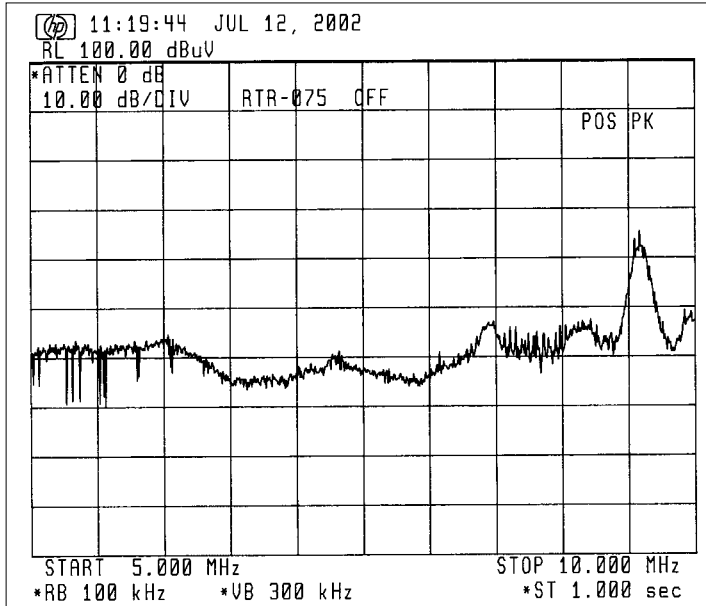

Ref. level (dB μ V/m)
= 100 - 88 = 12 (at 5 MHz)
= 100 - 83 = 17 (at 7 MHz)
= 100 - 78 = 22 (at 10 MHz)

-20 dB μ V/m limit line

(Band : 10 MHz - 30 MHz, Limit at 1 nm = 0.1 μ V/m = -20 dB μ V/m)

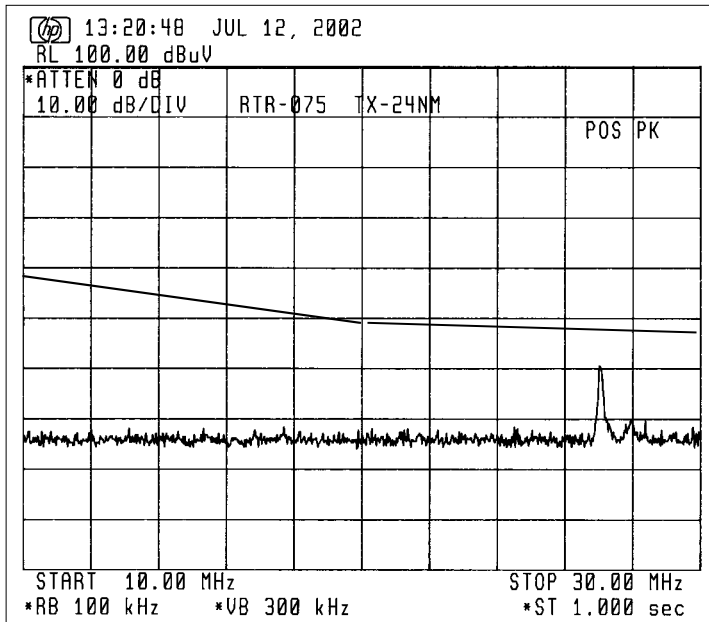
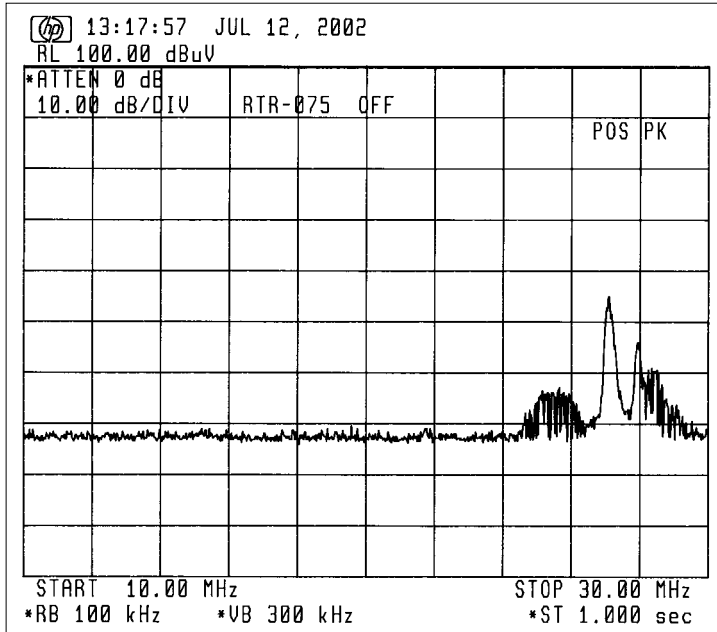

Ref. level (dB μ V/m)
= 100 - 78 = 22 (at 10 MHz)
= 100 - 70 = 30 (at 20 MHz)
= 100 - 67 = 33 (at 30 MHz)

-20 dB μ V/m limit line

(Band : 30 MHz - 100 MHz, Limit at 1 nm = 0.1 μ V/m = -10.5 dB μ V/m)

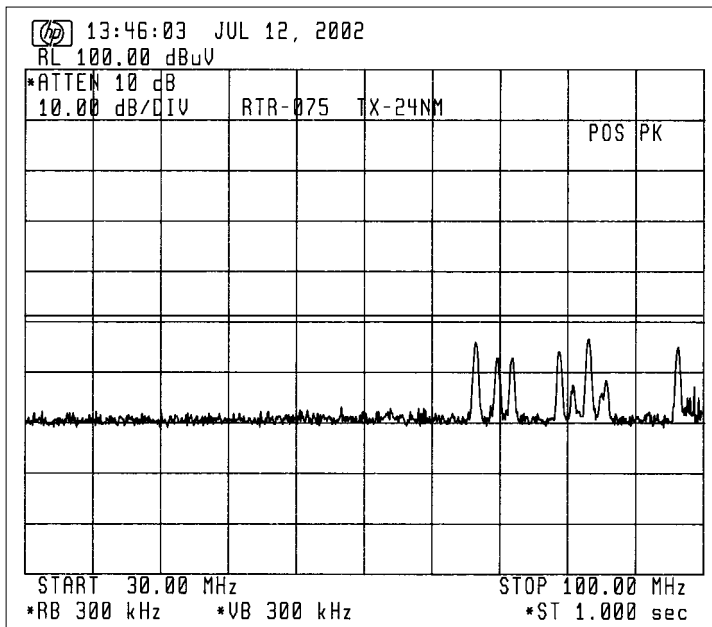
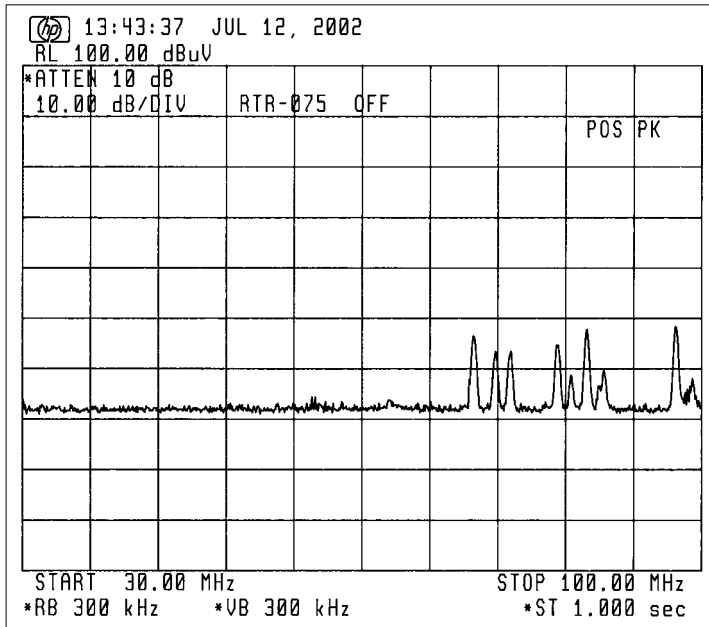

Ref. level (dB μ V/m)
= 100 - 61 = 39

- 10.5 dB μ V/m limit line

(Band : 100 MHz - 300 MHz, Limit at 1 nm = 0.1 μ V/m = -0 dB μ V/m)

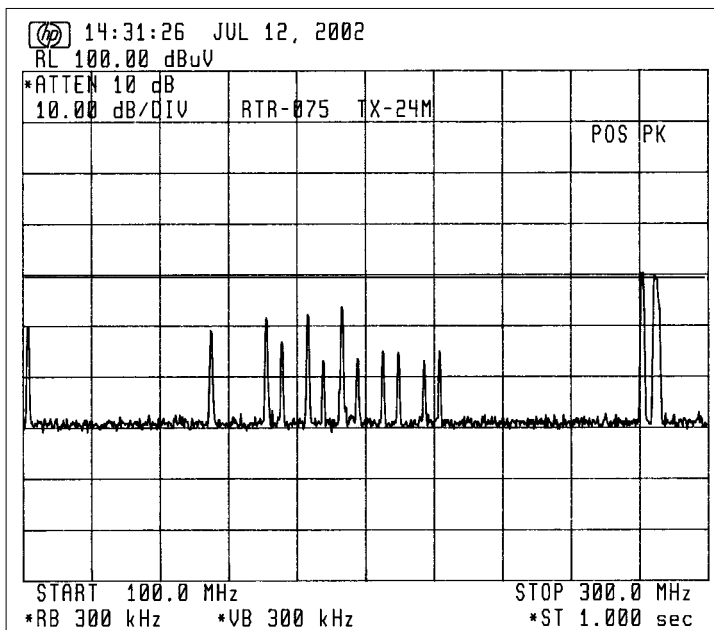
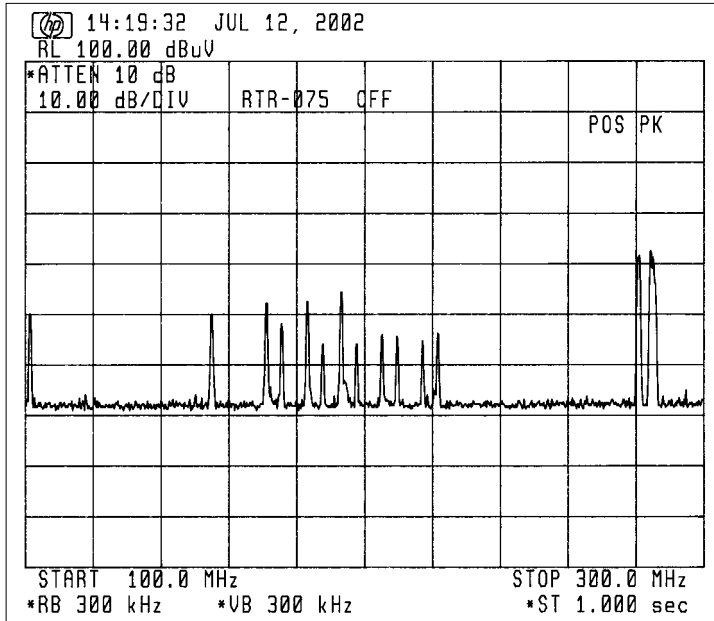

Ref. level (dB μ V/m)
= 100 - 60 = 40

0 dB μ V/m limit line

All components above the limit
are from external noise or
signals, not from RADAR.

(Band : 300 MHz - 1 GHz, Limit at 1 nm = 3 μ V/m = -9.5 dB μ V/m)

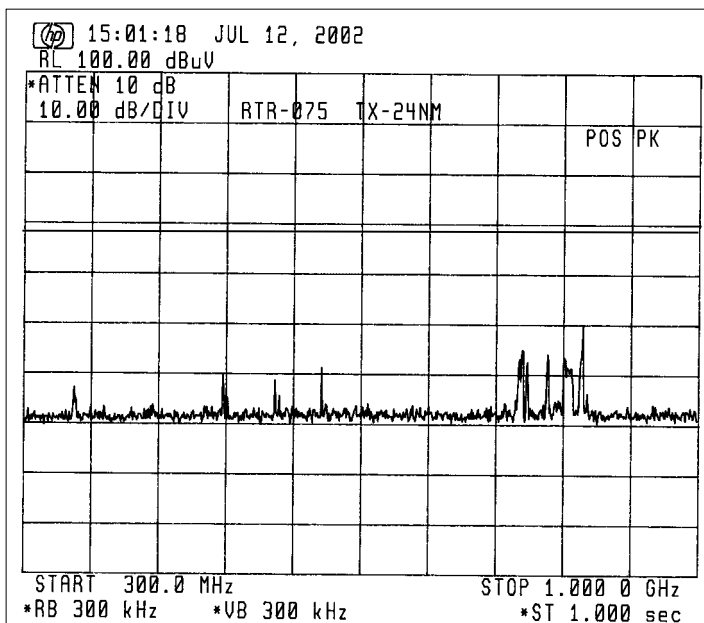
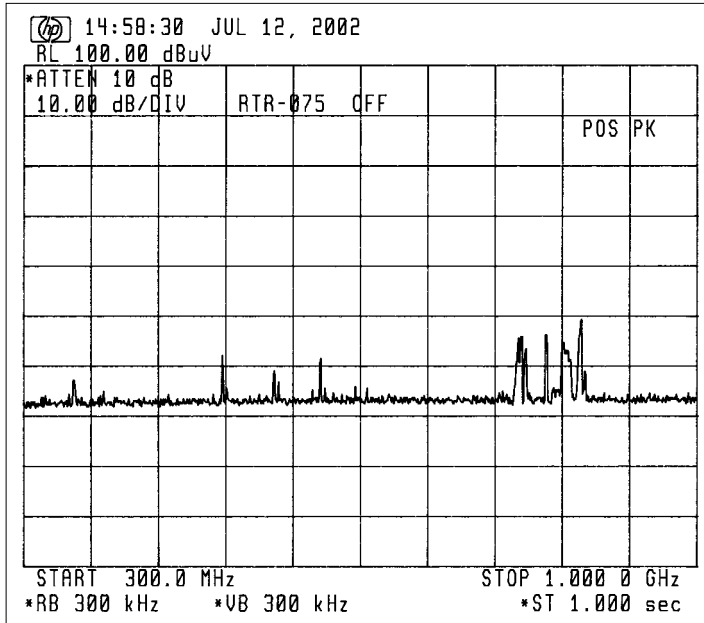

Ref. level (dB μ V/m)
= 100 - 59.5 = 40.5

9.5 dB μ V/m limit line

3. Power Input to an Artificial Antenna

(Band : 14 kHz - 490 kHz, Limit at 2 m = -81 dBm)

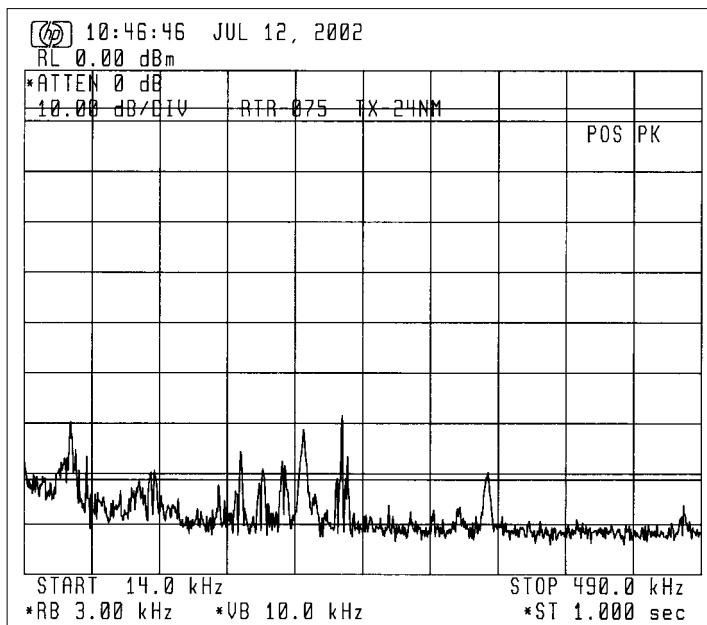
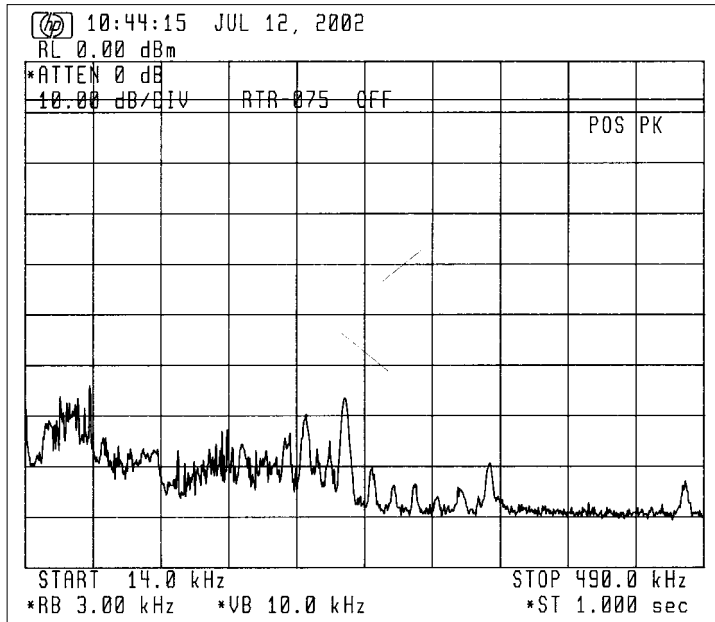

-81 dBm limit line

All components above the limit
are from external noise or
signals, not from RADAR.

(Band : 490 kHz - 5 MHz, Limit at 2 m = -81 dBm)

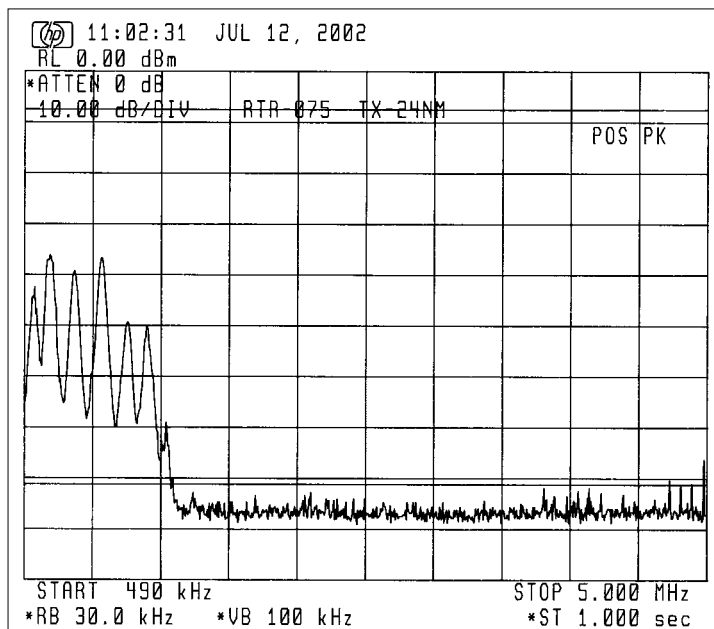
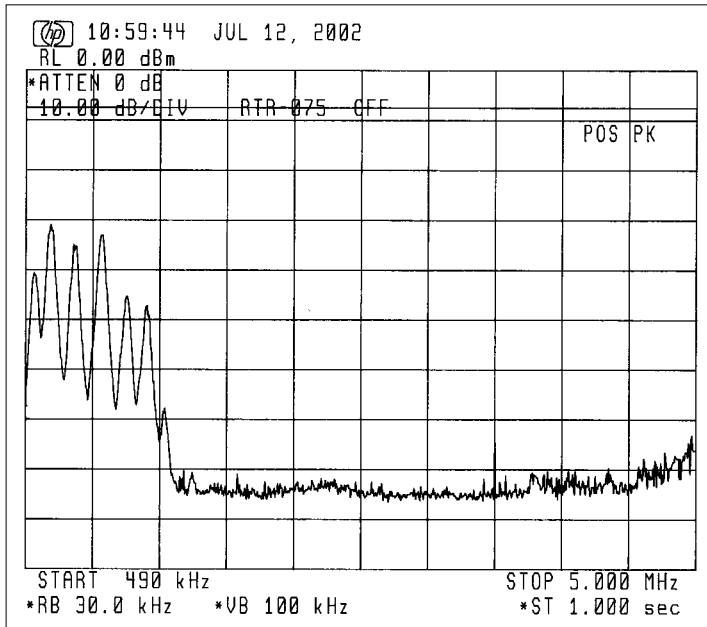

-81 dBm limit line

All components above the limit
are from external noise or
signals, not from RADAR.

(Band : 5 MHz - 10 MHz, Limit at 2 m = -81 dBm)

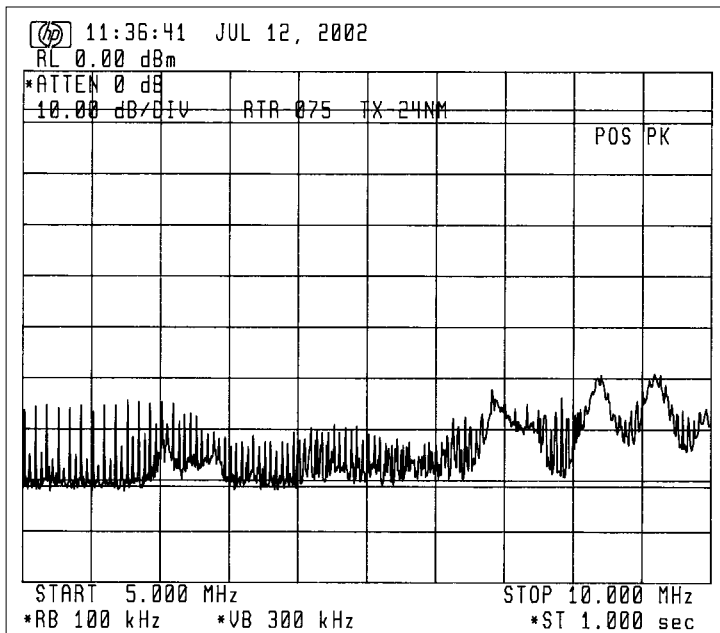
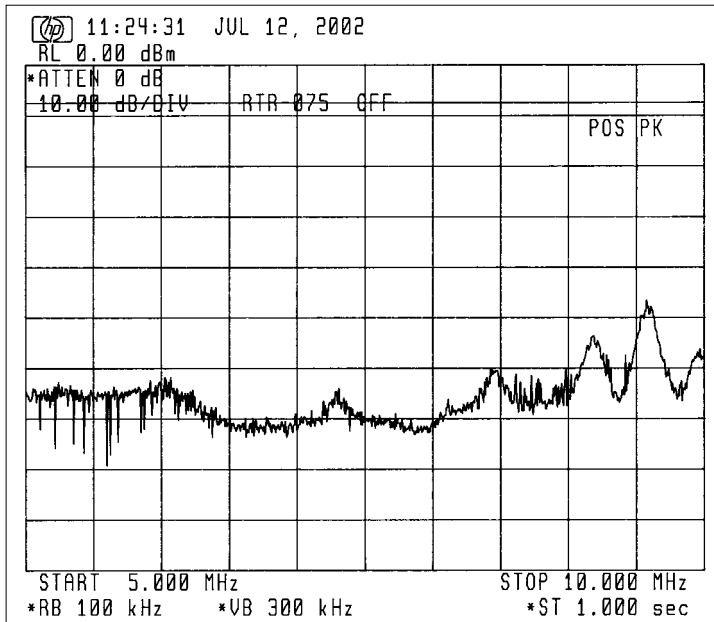

-81 dBm limit line

All components above the limit
are from external noise or
signals, not from RADAR.

(Band : 10 MHz - 30 MHz, Limit at 2 m = -81 dBm)

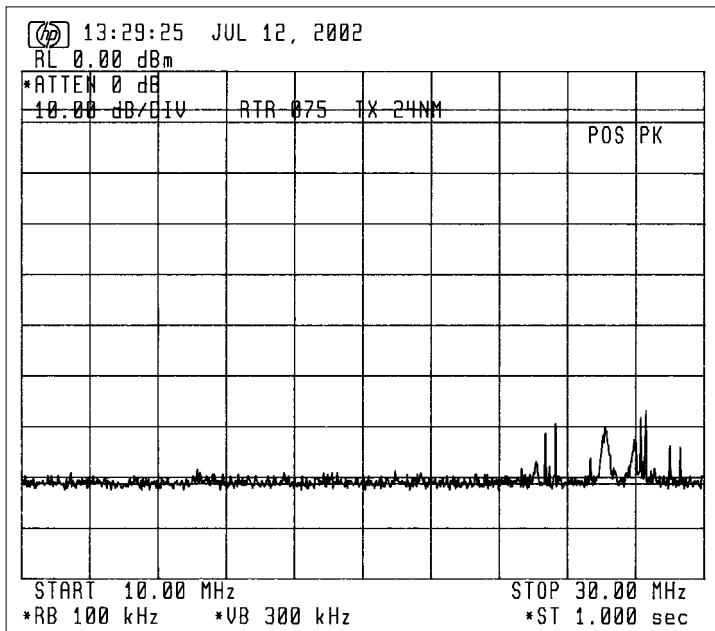
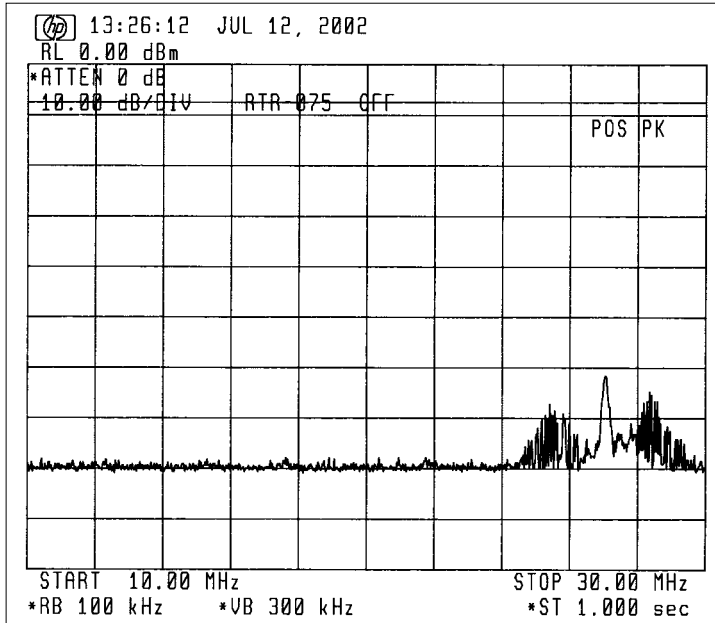

All components above the limit are from external noise or signals, not from RADAR.

(Band : 30 MHz - 100 MHz, Limit at 2 m = -71 dBm)

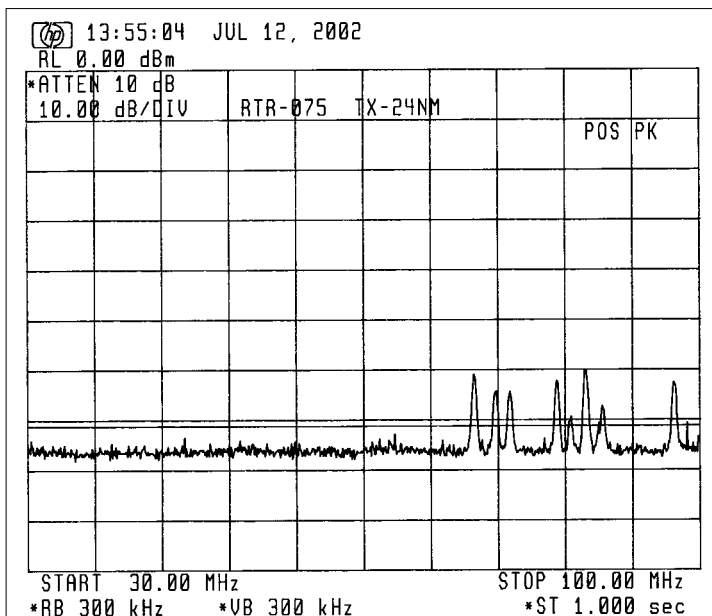
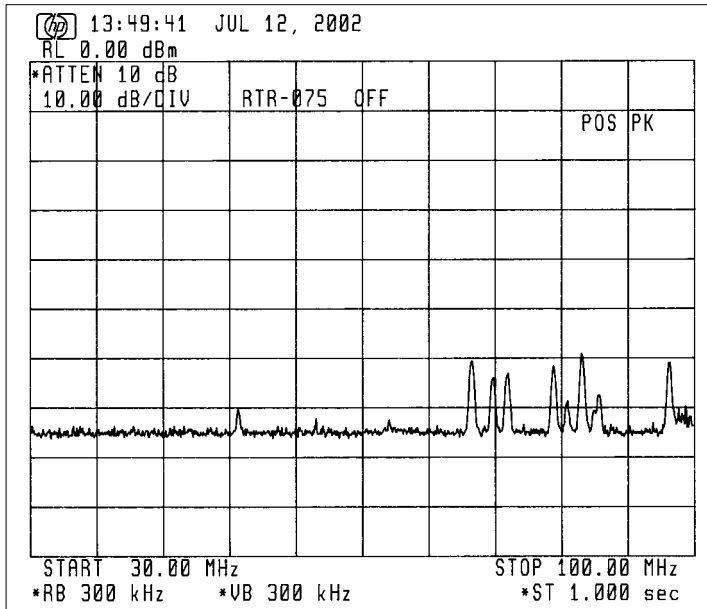

-71 dBm limit line

All components above the limit are from external noise or signals, not from RADAR.

(Band : 100 MHz - 300 MHz, Limit at 2 m = -61 dBm)

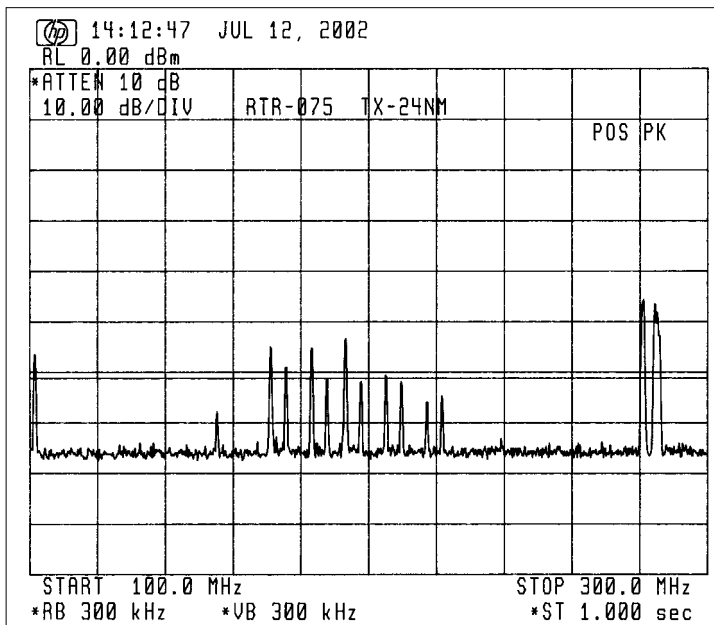
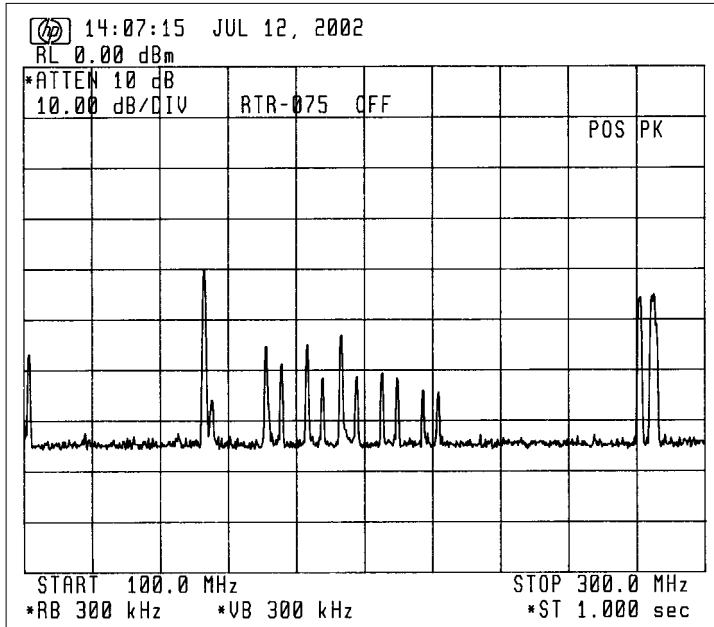

-61 dBm limit line

All components above the limit are from external noise or signals, not from RADAR.

(Band : 300 MHz - 1 GHz, Limit at 2 m = -51 dBm)

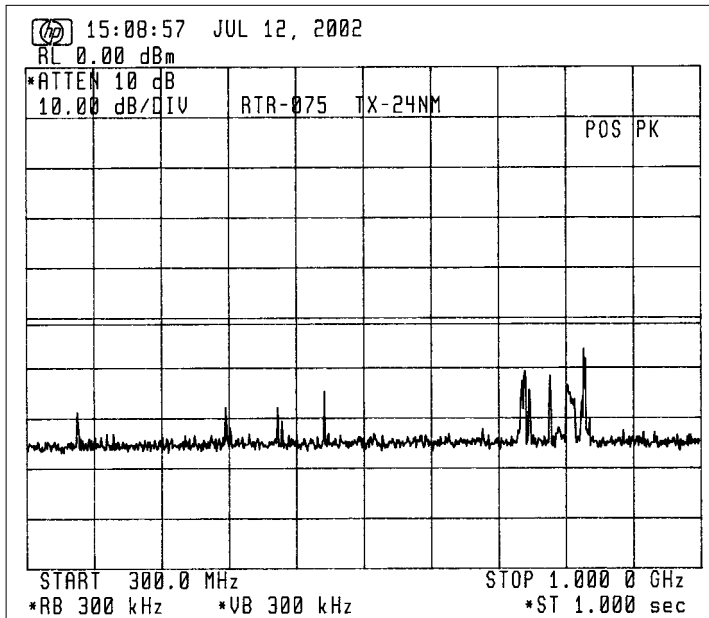
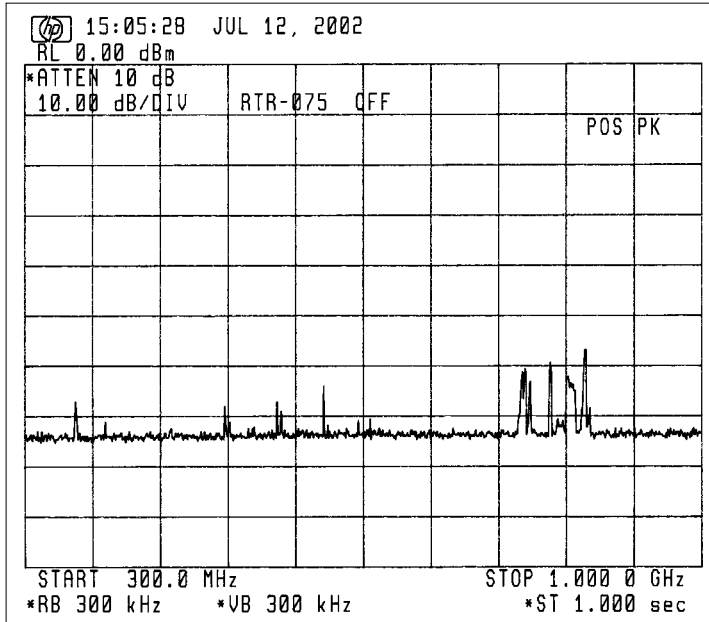

Attachment D [List of Test/Measuring Equipment] (for X-band radar)

For Clause 3.1 RF Power Output

<u>Model</u>	<u>Type</u>	<u>Serial no.</u>	<u>Mfr.</u>
Spectrum Analyzer	71210C	2927A02847	HP
Oscilloscope	TDS680B	B030202	Tektronix
Directional Coupler	5D364S	R05762	Shimada
Voltage Divider	HV-P30	2780	Iwatsu
Current Transformer	2100	----	Pearson Electronics
Power Meter	436A	2410A19137	HP
Power Sensor	8481A	2349A39603	HP
Frequency Counter	TR5824A	41940036	Advantest
Frequency Meter	X532B	1441A00523	HP
Crystal Detector	423A	1822A09909	HP
Dummy Load	4D376	R05763	Shimada
Attenuator (1 dB step)	8494B	US00430029	HP
Attenuator (10 dB step)	8495B	3308A22026	HP

For Clause 3.2 Modulation Characteristics

<u>Model</u>	<u>Type</u>	<u>Serial no.</u>	<u>Mfr.</u>
Spectrum Analyzer	71210C	2927A02847	HP
Oscilloscope	TDS680B	B030202	Tektronix
Crystal Detector	423A	1822A09909	HP
Directional Coupler	5D364S	R05762	Shimada
Dummy Load	4D376	R05763	Shimada
Voltage Divider	HV-P30	2780	Iwatsu
Attenuator (1 dB step)	8494B	US00430029	HP
Attenuator (10 dB step)	8495B	3308A22026	HP

For Clause 3.4 Spurious Emissions at Antenna Terminal

<u>Model</u>	<u>Type</u>	<u>Serial no.</u>	<u>Mfr.</u>
Spectrum Analyzer	71210C	2927A02847	HP
Attenuator (10 dB step)	8495B	3308A22026	HP
External Mixer:	11970K	2332A00589	HP
External Mixer:	11970A	2332A01187	HP
Directional Coupler	5D364S	R05762	Shimada
Dummy Load	4D376	R05763	Shimada
High Pass Filter (X-band)	----	----	Furuno

For Clause 3.5 Field Strength of Spurious Radiation

<u>Model</u>	<u>Type</u>	<u>Serial no.</u>	<u>Mfr.</u>
Spectrum Analyzer:	71210C	2927A02847	HP
Broadband Rod Antenna	95010-1	---	Advanced Electronics
Biconical Antenna	BIA-25	2650	Electro Metrics
Conical Log-Spiral Antenna	LCA-25	2886	Electro Metrics
Double Ridged Guide Horn Antenna :RGA-180		2248	Electro Metrics
Horn Antenna:	----	----	Toshiba
External Mixer:	11970K	2332A00589	HP
External Mixer:	11970A	2332A01187	HP
Attenuator (10 dB step)	8495B	3308A22026	HP
High Pass Filter (X-band)	---	---	Furuno

For Clause 3.6 Frequency Stability

<u>Model</u>	<u>Type</u>	<u>Serial no.</u>	<u>Mfr.</u>
Power Meter:	436A	2410A19137	HP
Power Sensor:	8481A	2349A39603	HP
Frequency Meter:	X532B	1441A00523	HP
Directional Coupler:	5D364S	R5762	Shimada
Dummy Load:	4D376	R05763	Shimada
Environmental Chamber:	TBE-3WA4YPX	4420569	Tabai Espec

For Clause 3.7 Suppression of Interference Aboard Ships

<u>Model</u>	<u>Type</u>	<u>Serial no.</u>	<u>Mfr.</u>
Spectrum Analyzer:	71210C	2927A02847	HP
6 m Whip Antenna	14 k - 10 MHz	----	Furuno
4 m Whip Antenna	10 - 30 MHz	----	Furuno
VHF Whip Antenna	30 - 300 MHz	150M-W2UM	Anten
UHF Whip Antenna	300 - 1000 MHz	----	Anten
Network analyzer:	8753C	3214J01067	HP
Spectrum Analyzer	TR4172	30690116	Advantest
Spectrum Analyzer	8566B	2637A03642	HP
Attenuator (10 dB step)	8495B	3308A22026	HP