

**LABOTECH**

# **TECHNICAL INFORMATION**

**TEST REPORT ON THE PERFORMANCE OF  
MARINE RADAR**

---

**Trade Mark : FURUNO**  

---

**Transceiver Type : RTR-051**

Report no.: FLI 12-00-029

Date of issue: December 25, 2000

Furuno Labotech International Co., Ltd.  
9-52 Ashihara-cho, Nishinomiya City, Hyogo 662-8580, Japan  
Tel: +81-798-63-1094 Fax: +81-798-63-1098

All tests were performed in Furuno Labotech International Co., Ltd.

All data herein contained is true and correct to our best knowledge.

All tests were performed by:

Name : Katsumi Imamura

Function : Test Engineer

Signature 

Review and report by:

Name : Toshiro Segawa

Function : Manager, QA

Signature 

This report has been verified and approved by:

Date : December 25, 2000

Name : Mitsuyoshi Komori

Function : Manager, Technical Section

Signature 

\* \* \* \* \* **C O N T E N T S** \* \* \* \* \*

<b>1</b>	<b>General Information.....</b>	<b>3</b>
<b>2</b>	<b>Identification of Equipment (FCC Rule §2.925) .....</b>	<b>10</b>
<b>3</b>	<b>Test data .....</b>	<b>11</b>
3.1	RF Power Output (FCC Rule §2.1046).....	11
3.2	Modulation Characteristics (FCC Rule §2.1047) .....	14
3.3	Occupied Bandwidth (FCC Rule §2.1049) .....	19
3.4	Spurious Emissions at Antenna Terminal (FCC Rule §2.1051).....	21
3.5	Field Strength of Spurious Radiation (FCC Rule §2.1053).....	23
3.6	Frequency Stability (FCC Rule §2.1055).....	25
3.7	Suppression of Interference Aboard Ships (FCC Rule § 80.217) .....	28
<b>4</b>	<b>Photographs to Reveal Equipment Construction and Layout (FCC Rule §2.1033).....</b>	<b>32</b>
<b>5</b>	<b>Description of Circuitry and Devices (FCC Rules §2.1033).....</b>	<b>33</b>
5.1	Function of Each Semiconductor or Active Device.....	33
5.2	Description of the circuits employed for suppression of spurious radiation, for limiting or shaping the control pulse, and for limiting or controlling power .....	35
<b>6</b>	<b>Operator's Manual Incl. Circuit Diagrams (FCC Rule §2.1033).....</b>	<b>37</b>
Attachment A	[ Test data for 3.4 Spurious Emissions at Antenna Terminal ] .....	A.1 - A.6
Attachment B	[ Test data for 3.5 Field Strength of Spurious Radiation ] .....	B.1 - B.3
Attachment C	[ Test data for 3.7 Suppression of Interference Aboard Ships ] .....	C.1 - C.21
Attachment D	[ List of Test/ Measuring Equipment ] .....	D.1 - D.3
Attachment E	[ Photographs of the EUT ] .....	E.1 - E.26

## 1 General Information

### 1.1 General

- (a) Manufacturer: Furuno Electric Co., Ltd.  
9-52 Ashihara-cho, Nishinomiya-city, 662-8580 Japan
- (b) Model: MODEL 1742

Display unit	RDP-130 (S/N: 4305-0020 )
Antenna unit:	RSB-0047 (S/N: R120-0005)
Transceiver	RTR-051
Radiator	XN065AF

- (c) Primary Function: Search, Navigation and anticollison
- (d) Discrimination  
Range Discrimination: 25 meters on a range scale of 1.5 nm  
Bearing Discrimination: 3.50° on a range scale of 1.5 nm
- (e) Minimum Range: 37 meters on a range scale of 0.25 nm
- (f) Frequency Range: Fixed frequency, X-band  
Type of Emission: P0N
- (g) Power Supply: 12 - 24 VDC

### 1.2 Antenna Unit

#### 1.2.1 Transceiver

**Type: RTR-051**

#### (1) Transmitter

- (a) Assignable Frequency for Shipborne Radar:  
Between 9300 and 9500 MHz (FCC Rule § 80.375 (d)-(1))
- (b) Type of RF Generator  
Magnetron Type: E3587  
Peak Output Power: 2.2 kW nominal
- (c) Magnetron Ratings  
Center frequency of Magnetron: 9410 MHz  
Tolerances  
E3587  
Manufacturing: ± 30 MHz  
Pulling: 18 MHz  
Tolerance for 20°C temperature variation: -5 MHz

(d) Guard Band:

Guard Band is specified to be equal to  $1.5/T$  MHz, where "T" is the pulselength in microseconds. See para (e). (FCC Rule §80.209 (b))

(e) Pulse Characteristics:

Range Scale (nm)	(Short)	(Middle)	(Long)
	0.125		
	<u>0.25</u>		
	0.5		
	0.75		
	1	1	
	1.5	1.5	
		2	
		3	
			3
			4
			6
			8
			12
			16
			24
			<u>36</u>
Pulselength (μs)	0.08	0.30	0.80
P. R. R. (Hz)	2100	1200	600
Duty cycle	$1.68 \times 10^{-4}$	$3.60 \times 10^{-4}$	$4.80 \times 10^{-4}$
Guard Band (MHz)	18.75	5.00	1.88

Note: Tests were carried out for the underlined Range Scales.

**(2) Modulator**

- (a) FET Type: 2SK1449  
Trigger Voltage: Approx. +10 VDC positive

**(3) Receiver**

- (a) Passband (MHz)  
RF Stage: 100 MHz  
IF Stage:

Pulselength	Short	Middle	Long
(MHz)	7	7	7

## Video Amp.:

Pulselength	Short	Middle	Long
(MHz)	14	14	3

- (b) Gain (overall) (dB): Sufficient to cause limiting, approximately 130  
(c) Overall Noise Figure (dB): 9 (typical)  
(d) Video Output Voltage (V): 3.8 V positive across 400 ohms  
(e) Features Provided:  
Sensitivity Time Controls (Anti-clutter Sea),  
Fast Time Constant (Anti-clutter Rain)  
(f) If receiver is tunable, describe method of adjusting frequency:  
Adjustment of tuning voltage of receiver local oscillator (Automatic and manual)

**1.2.2 Antenna**

- (a) Antenna Rotation ON-OFF Switch:  
Not Provided.  
(b) Reflector: Type: XN065AF  
Slotted waveguide array, 65 cm long  
(c) Type of Beam: Vertical fan  
(d) Beam Width (between half-Radiator power points)

Horizontal	3.5 °
Vertical	30 °

- (e) Polarization: Horizontal
- (f) Antenna Gain: 25 dB
- (g) Attenuation of Major Side Lobes with respect to main beam:

Within $\pm 20^\circ$	+20 dB or less
Outside $\pm 20^\circ$	+28 dB or less

- (h) Scanning (rotating or oscillating):  
Rotating over  $360^\circ$  continuously clockwise
- (i) Antenna Rotation Rate: 24 rpm
- (j) Number of Degrees Scanned:  $360^\circ$
- (k) Sector Scan: Not provided.
- (l) Type of Transmission System: Contained in scanner unit
- (m) Rated Loss of Transmission System per hundred feet:  
None. Transmission path is only in the antenna scanner unit.

### 1.3 Display Unit

- (a) Type: 6.5 (in.) monochrome LCD  
240 X 320 pixels
- (b) Size of Indicator: 6.5 in. diagonal  
effective dia. 96 mm
- (c) Sweep Linearity: 2 % on all ranges

(d) Range Scales:

Range (nm)	Number of Range Rings	Range Ring Interval (nm)
0.125	2	0.0625
0.25	2	0.125
0.5	4	0.125
0.75	3	0.25
1	4	0.25
1.5	3	0.5
2	4	0.5
3	3	1
4	4	1
6	3	2
8	4	2
12	4	3
16	4	4
24	4	6
36	3	12

- (e) Range Ring Accuracy: Better than 0.9 % of maximum scale in use  
or 8 m, whichever is the greater
- (f) Overall Bearing Accuracy from Scanner to Display:  
Better than 1°
- (g) Target Plot Facility: Simulated afterglow in low shade
- (h) Heading Indicator: Provided, automatic alignment.  
Heading Line and Heading Marker
- (i) True Bearing Indicator: Not provided



## 1.4 Functional Controls

Range selector	Power Switch	FTC switch <sup>2)</sup>
A/C Rain control <sup>2)</sup>	STC control <sup>2)</sup>	Gain control <sup>2)</sup>
Panel dimmer <sup>2)</sup>	Heading line off	Echo stretch <sup>2)</sup>
MENU	Guard zone <sup>2)</sup>	Range ring on/off <sup>2)</sup>
Interference rejector <sup>2)</sup>	ST-BY/TX <sup>2)</sup>	Arrow keys (VRM/EBL/GUARD)
VRM on/off <sup>2)</sup>	SHIFT	Range set <sup>2)</sup>
Zoom <sup>2)</sup>	EBL on/off <sup>2)</sup>	Echo Trail <sup>2)</sup>
Contrast <sup>2)</sup>	PLOT brilliance <sup>2)</sup>	Navigation on/off <sup>1),2)</sup>
Anchor watch <sup>2)</sup>	Display brilliance <sup>2)</sup>	TRU/REL <sup>2),3)</sup>
Mode <sup>2),3)</sup>	TLL <sup>2),3)</sup>	Offcenter <sup>2)</sup>
Chart display <sup>2)</sup>	Waypoint <sup>2)</sup>	Date box <sup>1),2)</sup>

Note: <sup>1)</sup> Valid when interfaced with Navaid

<sup>2)</sup> Selected on menu

<sup>3)</sup> Valid when interfaced with gyrocompass

## 1.5 Operational Features

(a) Is positive means provided to indicate whether or not the overall operation of the equipment is such that it may be relied upon to provide effective operation in accordance with its primary function:

Yes (Magnetron/Xtal checker)

(b) Is the equipment for continuous operation: Yes

(c) Is provision made for operation with shore based radar beacons (RACONS):

Yes (RACONS and SART)

## 1.6 Line Power Supply Requirements

(a) Input Voltage: 12 - 24 VDC

(b) Power Drain: 47 W (for Model 1742)

## 1.7 Construction Features

(a) Does equipment embody replacement units with chassis type assembly: Yes

(b) Are fuse alarms provided: Fuses are provided.

(c) State units that are weatherproof: Antenna Unit (IEC 60529 - IPX6)

(d) If all units are not housed in a single container, indicate number and give description of individual units:

1 × Display Unit	Type:	RDP-130 (with monochrome LCD)
1 × Antenna Unit	Type:	RSB-0047
Transceiver	Type:	RTR-051 (contained in the Antenna unit)

(e) Approximate Weight of Complete Installation:

Display Unit:	3.5 kg
Antenna Unit:	11 kg

(f) Approximate space required for installation excluding scanner

Display Unit:	
RDP-130	418 mm (W) X 253 mm (H) X 306 mm (D)

## 2 Identification of Equipment (FCC Rule § 2.925)

The following nameplates are permanently fixed on the corresponding equipment units.

FCC ID: ADB9ZWRTR051

Material of nameplate: Polyester film, 0.1 mm thick

MARINE RADAR ANTENNA UNIT	
TYPE	RSB-0047
SER. NO.	R068-0005
FCC ID:	ADB9ZWRTR051
FURUNO USA, INC.	
COMPASS SAFE DISTANCE	
STD	2.05 M
STEER	1.57 M
FURUNO ELECTRIC CO., LTD.	
9-52 Ashihara-Cho, Nishinomiya	
City, Japan MADE IN JAPAN	



**Fig. 2.1**  
Nameplate for  
Antenna Unit

MARINE RADAR	
MODEL	1742
DISPLAY UNIT	
TYPE	RDP-130
INPUT	12 - 24 VDC
SER. NO.	4305-0020
COMPASS SAFE DISTANCE	
STD	M
STEER	M
FURUNO ELECTRIC CO., LTD.	
9-52 Ashihara-Cho, Nishinomiya	
City, Japan MADE IN JAPAN	

360

**Fig. 2.2**  
Nameplate for  
Display Unit RDP-130

## 3 Test data

### 3.1 RF Power Output (FCC Rule § 2.1046)

#### 3.1.1 Microwave characteristics

The peak voltage was determined using the divider having a ratio of 1000 to 1 and the oscilloscope. Current pulse was viewed across the wideband current transformer with output voltage per ampere 1.00.

##### (1) Nominal values

Pulselength	Short	Middle	Long
Range scale (nm)	0.25	2	36
Pulselength ( $\mu$ s)	0.08	0.30	0.80
PRR (Hz)	2100	1200	600
Duty cycle	$1.68 \times 10^{-4}$	$3.60 \times 10^{-4}$	$4.80 \times 10^{-4}$
Guard band (MHz)	18.75	5.00	1.88

##### (2) Measured values

#### Magnetron input pulse voltage

Magnetron input pulse voltage was measured at its cathode using the oscilloscope and divider with ratio 1000 to 1.

Pulselength	Short	Middle	Long
Directional coupler attenuation (dB)	40.44	40.44	40.44
Magnetron input voltage (kV)	2.2	2.3	2.3
Pulselength ( $\mu$ s) (50 % amplitude)	0.524	0.676	1.064
Rise time ( $\mu$ s) (10-90 % amplitude)	0.076	0.094	0.116
Decay time ( $\mu$ s) (90-10 % amplitude)	0.924	0.904	0.460

### Magnetron input pulse current

Magnetron input pulse current was observed across the wideband current transformer with output voltage per ampere 1.00.

Pulselength	Short	Middle	Long
Magnetron input current (A)	1.8	2.1	2.1
Pulselength ( $\mu$ s) (50 % amplitude)	0.121	0.300	0.832
Rise time ( $\mu$ s) (10-90 % amplitude)	0.115	0.156	0.170
Decay time ( $\mu$ s) (90-10 % amplitude)	0.062	0.067	0.068

### RF envelope of the magnetron output pulse

The RF envelope of the magnetron output pulse was measured using a diode and the oscilloscope with the following results:

Pulselength	Short	Middle	Long
Pulselength ( $\mu$ s) (-3 dB points)	0.110	0.287	0.804
Rise time ( $\mu$ s) (10-90 % amplitude)	0.043	0.064	0.090
Decay time ( $\mu$ s) (90-10 % amplitude)	0.074	0.077	0.076

### Estimated efficiency

The estimated efficiency of the RF generator (magnetron) was determined by the following measurements and calculation. Power output from magnetron was measured using the directional coupler, power meter and the oscilloscope.

Pulselength	Short	Middle	Long
Range scale (nm)	0.25	2	36
P.R.R (Hz)	2092.3	1236.4	604.4
Duty cycle	$2.30 \times 10^{-4}$	$3.54 \times 10^{-4}$	$4.85 \times 10^{-4}$
Magnetron input, av. (W)	0.91	1.71	2.35
Magnetron input, peak (kW)	3.96	4.83	4.83
Power meter reading (mW)	0.0321	0.0566	0.0813
Magnetron output, av. (W)	0.355	0.626	0.900

Pulselength	Short	Middle	Long
Spurious response limits (dB)	38.51	40.97	42.54
Magnetron Output, peak (kW):	1.54	1.77	1.85
Magnetron efficiency (%):	39.0	36.5	38.3

Peak Power Input to RF Generator : 4.5 kW  
Estimated Efficiency of RF Generator : 38.0 %

## 3.2 Modulation Characteristics (FCC Rule § 2.1047)

### 3.2.1 FET Trigger Pulse

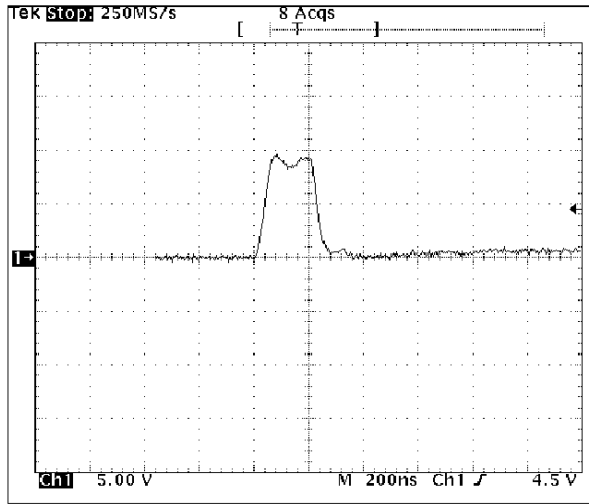

Fig. 3.2.1.1

Typical waveform of Trigger Pulse

Scale: 5 V/div., 200 ns/div.

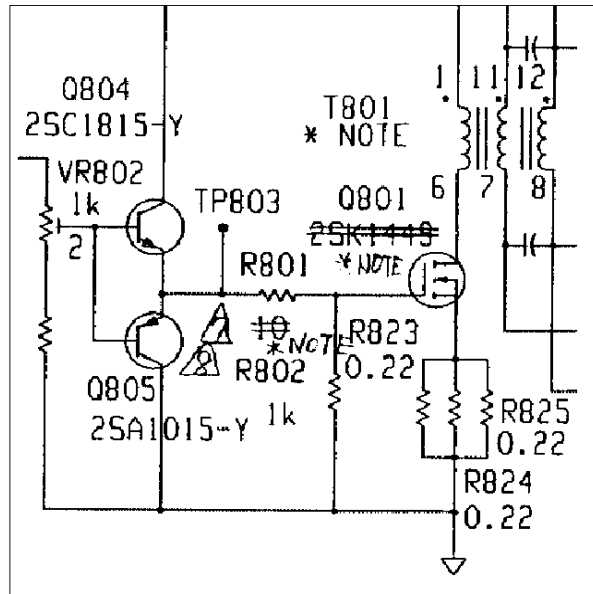

Fig. 3.2.1.2 Test Point for Trigger Pulse  
(in MD board (MD9052) of Radar Antenna Unit)

## 3.2.2 Trigger Pulse at Magnetron Cathode

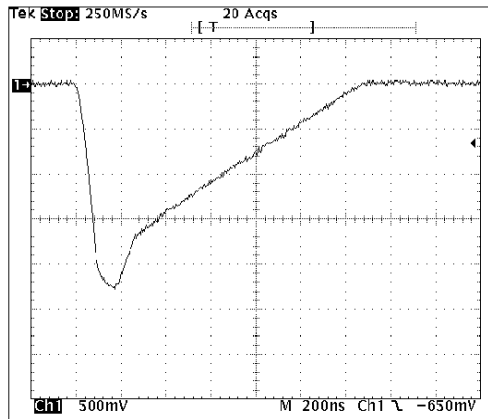

Fig. 3.2.2.1

Short Pulse (0.25 nm Range)

Scale: 500 V/div. 200 ns/div.

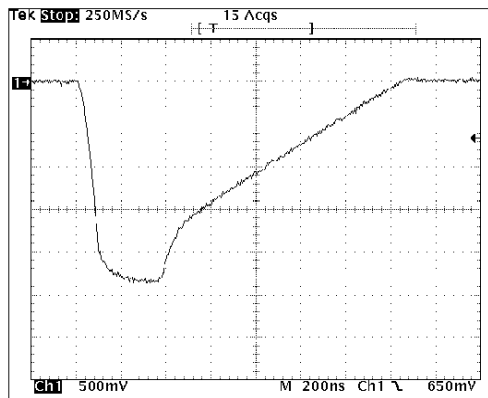

Fig. 3.2.2.2

Middle Pulse (2 nm Range)

Scale: 500 V/div. 200 ns/div.

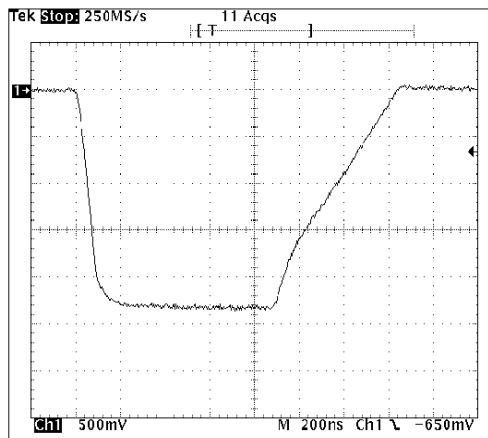

Fig. 3.2.2.3

Long Pulse (36 nm Range)

Scale: 500 V/div. 200 ns/div.



### 3.2.3 Magnetron Output (detected):

#### 3.2.3.1 Setup for Measurement:

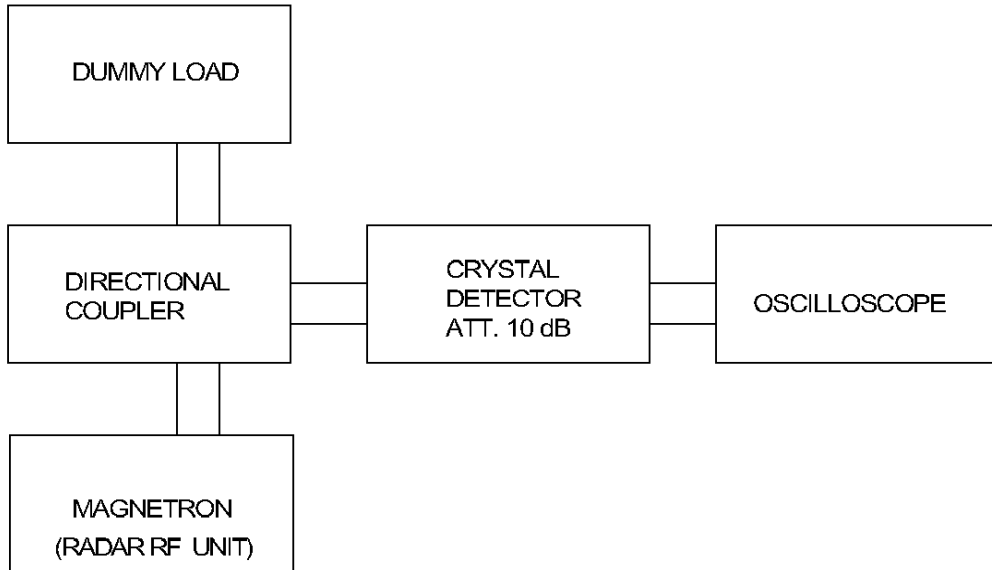

Fig. 3.2.3.1

#### 3.2.3.2 Measuring Equipment List:

See Attachment D [ List of Test/Measuring Equipment ].

### 3.2.3.3 Measured Data:

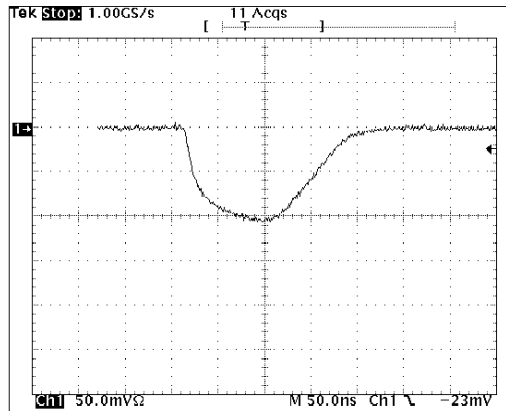

Fig. 3.2.3.2

Short Pulse (0.25 nm Range)

Scale: 50 mV/div. 50 ns/div.

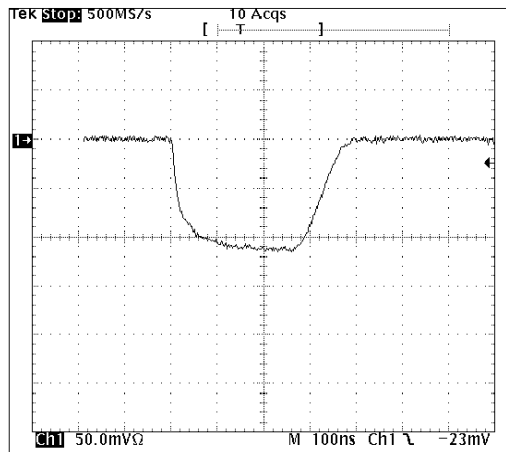

Fig. 3.2.3.3

Middle Pulse (2 nm Range)

Scale: 50 mV/div. 100 ns/div.

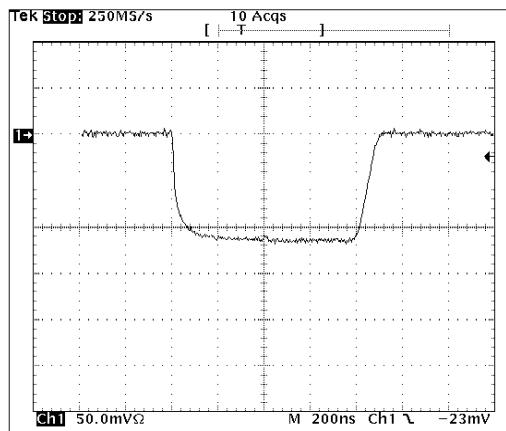

Fig. 3.2.3.4

Long Pulse (36 nm Range)

Scale: 50 mV/div. 200 ns/div.

### 3.2.4 Radar Pulse Spectrum:

Measured by the spectrum analyzer.

(Test Equipment Setup and Measuring Equipment List are same as Clause 3.4.1 and 3.4.2.)

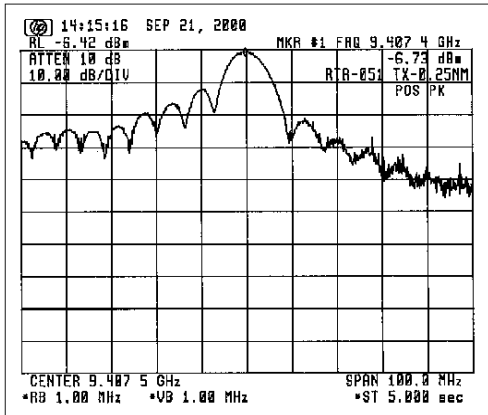

Fig. 3.2.4.1 For Short Pulse (0.25 nm Range)

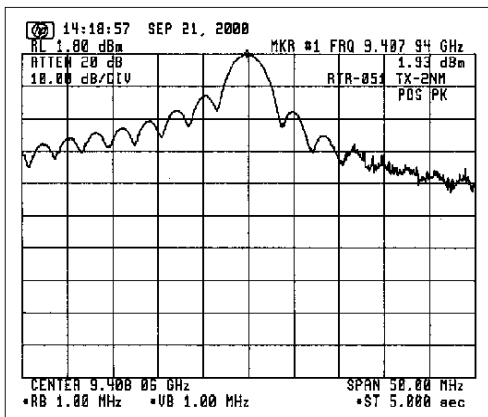

Fig. 3.2.4.2 For Middle Pulse (2 nm Range)

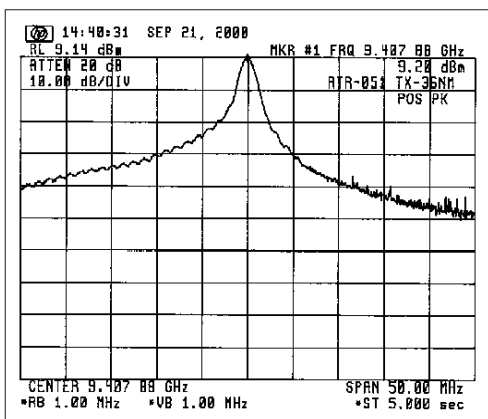

Fig. 3.2.4.3 For Long Pulse (36 nm Range)

## 3.3 Occupied Bandwidth (FCC Rule § 2.1049)

### 3.3.1 Measuring Method

FCC rule 47 CFR 2.1049 requires measurements of the occupied bandwidth which is defined in the same section as "the frequency bandwidth such that, below its lower and above its upper frequency limits, the mean powers radiated are each equal to 0.5 percent of the total mean power radiated by a given emission." To obtain the occupied bandwidth of the radar transmitter, a special program (program list shown below) was loaded to the Hewlett-Packard spectrum analyzer and run by entering the HP-provided POWER BANDWIDTH calculation command [PWRBW].

The result was automatically displayed on the screen on the spectrum analyzer as:

POWER\_BW=---- MHz

```
10 ! HP_71000 DOWNLOAD PROGRAM
20 ASSIGN @Sa TO 718
30 CLEAR @Sa
40 CALL M_ain(@Sa)
50 LOCAL @Sa
60 END
70 !
80 SUB M_ain(@Sa)
90 M_ain: !
100 CALL Pwr_bw(@Sa)
110 CALL Limit_line(@Sa)
120 !
130 OUTPUT @Sa;"VARDEF K_ey,0;";
140 !
150 OUTPUT @Sa;"FUNCDEF D_LP,^";
160 OUTPUT @Sa;"MOV K_ey,0;";
170 !
180 Main_menu: !
190 OUTPUT @Sa;"REPEAT;";
200 OUTPUT @Sa;"READMENU K_ey;";
210 ! location: %Top---Bottom-%
220 OUTPUT @Sa;"1,%Limit line %,";
230 OUTPUT @Sa;"2,%Power bw %,";
240 OUTPUT @Sa;"14,% Exit%,";
250 !
260 OUTPUT @Sa;"IF K_ey,EQ,1;THEN;LIMIT_LINE;";
270 OUTPUT @Sa;"ELSIF K_ey,EQ,2;THEN;PWR_BW;";
280 OUTPUT @Sa;"ELSIF K_ey,EQ,14;THEN;ABORT;";
290 OUTPUT @Sa;"ENDIF;";
300 OUTPUT @Sa;"UNTIL K_ey,EQ,14;";
310 OUTPUT @Sa;"IP;TS;";
320 OUTPUT @Sa;"ADORT;";
330 OUTPUT @Sa;"^"
340 !
350 Define_keydef: !
360 OUTPUT @Sa;"KEYDEF 7,D_LP, %DLP TEST%,";
370 !
380 OUTPUT @Sa;"FUNCDEF D,^";
390 OUTPUT @Sa;"KEYPST;";
400 OUTPUT @Sa;"^"
410 !
420 SUBEND

430 !
440 SUB Limit_line(@Sa)
450 Limit_line: !
460 OUTPUT @Sa;"CLR DSP;";
470 OUTPUT @Sa;"FUNCDEF LIMIT_LINE,^";
480 OUTPUT @Sa;"PU;PA 0,654;";
490 OUTPUT @Sa;"LINET 1;";
500 OUTPUT @Sa;"PD;PA 100,654;";
510 OUTPUT @Sa;"PU;PA 201,654;";
520 OUTPUT @Sa;"PD;PA 300,654;";
530 OUTPUT @Sa;"PU;PA 105,630;";
540 OUTPUT @Sa;"TEXT @-35dB@";
550 OUTPUT @Sa;"PU;PA 205,720;";
560 OUTPUT @Sa;"TEXT @-25dB@";
570 OUTPUT @Sa;"PU;PA 301,743;";
580 OUTPUT @Sa;"LINET 1;";
590 OUTPUT @Sa;"PD;PA 400,743;";
600 OUTPUT @Sa;"PU;PA 601,743;";
610 OUTPUT @Sa;"LINET 1;";
620 OUTPUT @Sa;"PD;PA 700,743;";
630 OUTPUT @Sa;"PU;PA 701,654;";
640 OUTPUT @Sa;"LINET 1;";
650 OUTPUT @Sa;"PD;PA 1000,654;HD;";
660 OUTPUT @Sa;"^"
670 SUBEND
680 SUB Pwr_bw(@Sa)
690 Pwr_bw: !
700 ! Calculating Power band width
710 OUTPUT @Sa;"VARDEF P_bw,0;";
720 OUTPUT @Sa;"FUNCDEF PWR_BW,^";
730 OUTPUT @Sa;"CLRW TRA;";
740 OUTPUT @Sa;"CLR DSP;";
750 OUTPUT @Sa;"SNGLS;";
760 OUTPUT @Sa;"MXMH TRA;TS;TS;TS;";
770 OUTPUT @Sa;"MOV P_bw,PWRBW TRA,99.0;";
780 OUTPUT @Sa;"DIV P__bw,P_bw,1000000;";
790 OUTPUT @Sa;"PU;PA 10,800;HD;";
800 OUTPUT @Sa;"TEXT @POWER_BW = @;";
810 OUTPUT @Sa;"DSPLY P_bw,8,3;";
820 OUTPUT @Sa;"TEXT @ MHz @;";
830 OUTPUT @Sa;"^"
840 SUBEND
```

Fig. 3.3.1

Program for Calculation of Occupied Bandwidth

### 3.3.2 Test Equipment Setup:

Same as Clause 3.4.1.

### 3.3.3 Measuring Equipment List:

Same as Clause 3.4.2.

### 3.3.4 Test Result:

The test result is shown below.

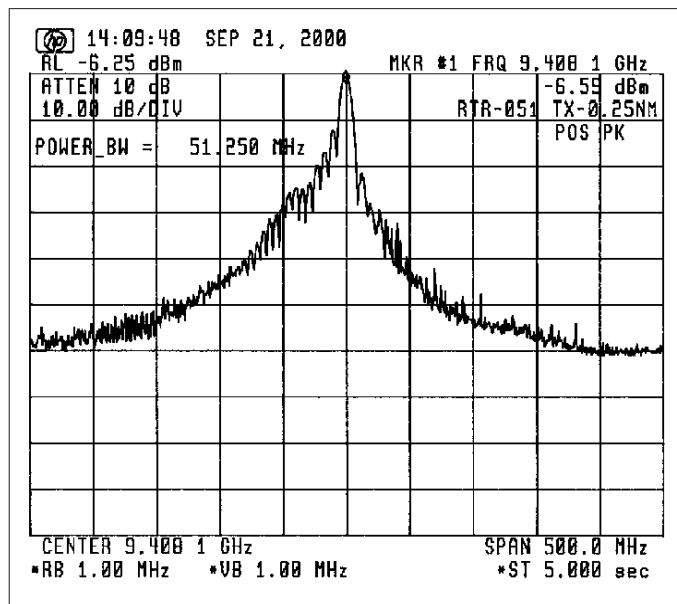

Fig. 3.3.2 Measurement of Occupied Bandwidth

**Occupied bandwidth = 51.250 MHz**

### 3.4 Spurious Emissions at Antenna Terminal (FCC Rule § 2.1051)

#### 3.4.1 Test Equipment Setup:

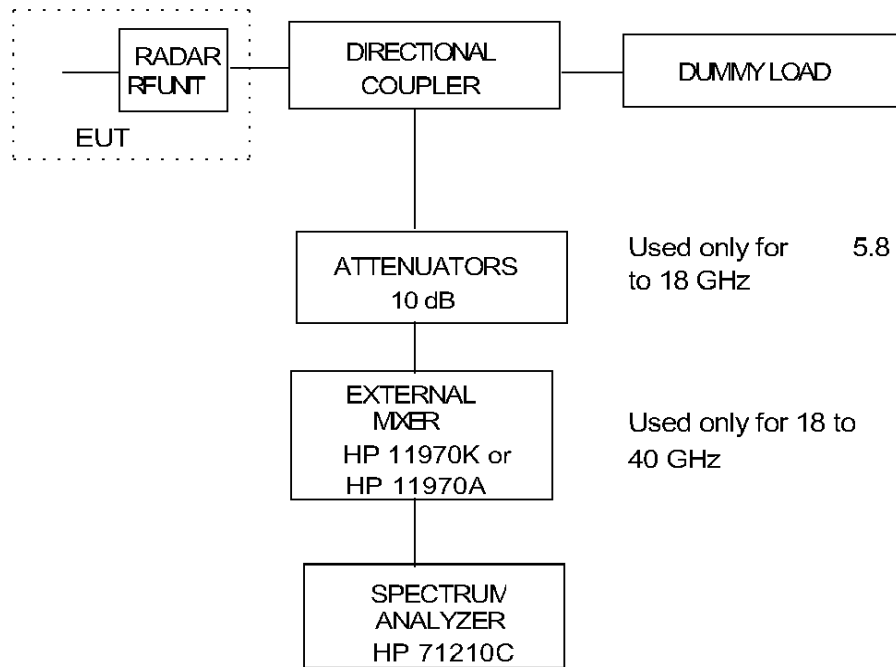

Fig. 3.4.1

#### 3.4.2 Measuring Equipment List:

See Attachment D [ List of Test/Measuring Equipment ].

### 3.4.3 Test Conditions:

Radar Range Settings: 0.25 nm (Short)/ 2 nm (Middle)/ 36 nm (Long)

### 3.4.4 Emission Limits:

(a) Frequency Range (FCC Rule § 2.1057(1)) : 10 kHz - 4 GHz

(b) Emission Limits (FCC Rule § 80.211) :

Frequency removed from the assigned frequency	Frequency (Hz)	Emission attenuation (mean power ,dB)
50 - 100 % (of the authorized bandwidth)	9310 - 9360 M	At least 25
	9460 - 9510 M	
100 - 250 %	9160 - 9310 M	At least 35
	9510 - 9660M	
more than 250 %	10 k - 9160M	At least $43 + 10 \log_{10}$ (mean power in watts)
	9660- 40,000 M	

Note : (1) Assigned frequency (center frequency) = 9410 MHz

(2) Authorized bandwidth = 100 MHz

### 3.4.5 Test Results:

As shown in Attachment A, the spurious emissions at antenna terminal of EUT are found lower than the specified limits.

(Note: Spurious emissions for 10 kHz to 5 GHz are not found due to the antenna terminal structure. (Waveguide tube)).

### 3.5 Field Strength of Spurious Radiation (FCC Rule § 2.1053)

**3.5.1 Test Site:** Rooftop of 6-story building,  
 FURUNO ELECTRIC CO., LTD.  
 Ashihara-cho 9-52, Nishinomiya-city, 662-8580 Japan

**3.5.2 Distance between the radar set and measuring antenna:** 10 m

**3.5.3 Radar Range settings:** 0.25 nm (Short)/ 2 nm (Middle)/ 36 nm (Long)

**3.5.4 Measuring Equipment List:**  
 See Attachment D [ List of Test/Measuring Equipment ].

**3.5.5 Test settings:**

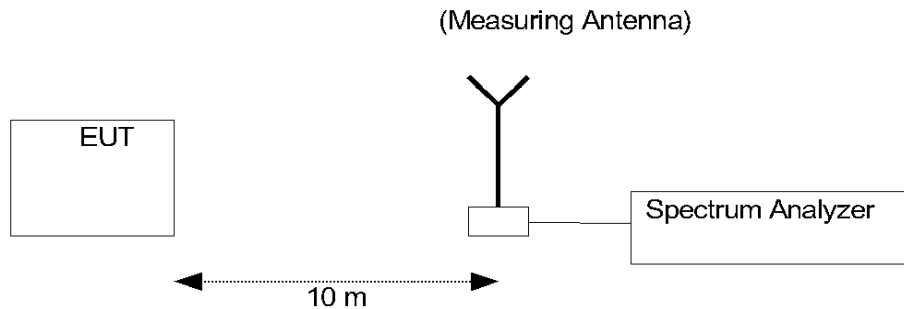

### 3.5.6 Field Strength Limits:

(a) Frequency Range (FCC Rule §2.1057(1)) : 10 kHz - 4 GHz

(b) Emission Limits (FCC Rule §80.211) :

Frequency removed from the assigned frequency	Frequency (MHz)	Emission attenuation (mean power, dB)
50 - 100 % (of the authorized bandwidth)	9,310 – 9,360	At least 25
	9,460 – 9,510	
100 - 250 %	9,160 – 9,310	At least 35
	9,510 – 9,660	



Frequency removed from the assigned frequency	Frequency (MHz)	Emission attenuation (mean power, dB)
more than 250 %	0.01 – 9,160 9,660 - 40,000	At least $43 + 10 \log_{10}$ (mean power in watts)

Note : (1) Assigned frequency (center frequency) = 9410 MHz

(2) Authorized bandwidth = 100 MHz

### 3.5.7 Test Results:

As shown in Attachment B, the field strengths of spurious radiation generated by the EUT are found lower than the specified limits.

## 3.6 Frequency Stability (FCC Rule §2.1055)

### 3.6.1 Setup for Measurement

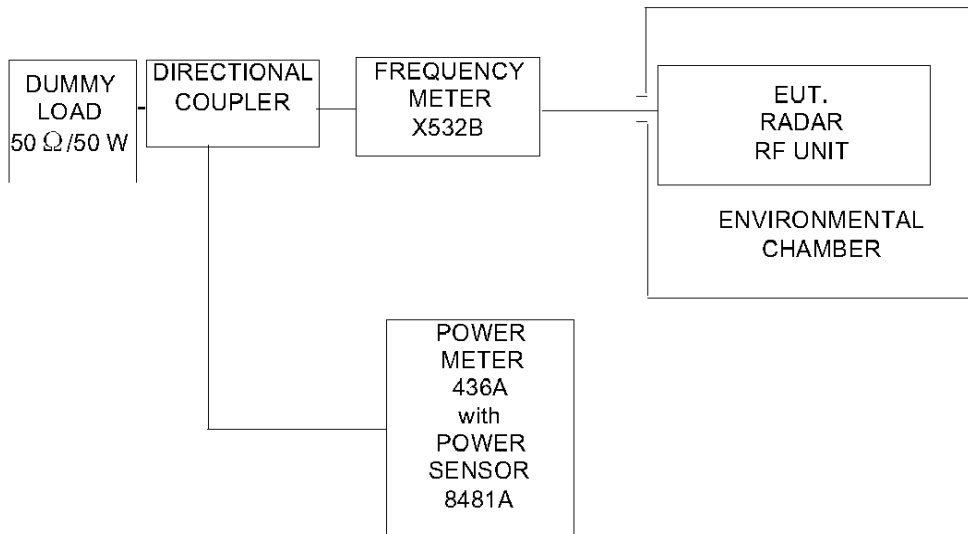

Fig. 3.6.1

### 3.6.2 Test Conditions:

- 1) Radar Range settings : 0.25 nm (Short)/ 2 nm (Middle)/ 36 nm (Long)
- 2) Ambient Temperature settings: - 20 to + 50 °C (10 °C step)
- 3) Power Supply Voltage settings: 85 / 115 % of nominal voltage (20.4 to 27.6 VDC)

### 3.6.3 Measuring Equipment List:

See Attachment D [ List of Test/Measuring Equipment ].

### 3.6.4 Frequency Tolerance Limits:

"The frequency at which maximum emission occurs must be within the authorized bandwidth and must not be closer than  $1.5/T$  MHz to the upper and lower limits of the authorized band width, where "T" is the pulse duration in microseconds. "

(FCC Rule § 80.209 (b))

1) Center frequency ( $f_0$ ): 9410 MHz

2) Authorized bandwidth ( $f(\text{AUBW})$ ): 100 MHz

"Upper limit frequency of the authorized band",  $f(\text{UAUBW}) = f_0 + f(\text{AUBW})/2 = 9460$  MHz

"Lower limit frequency of the authorized band",  $f(\text{LAUBW}) = f_0 - f(\text{AUBW})/2 = 9360$  MHz

3) Assignable frequency bandwidth : 200 MHz (between 9300 MHz and 9500 MHz)

(FCC Rule § 80.375 (d)-(1))

"Upper limit frequency of the assignable band",  $f(\text{UASB}) = 9500$  MHz

"Lower limit frequency of the assignable band",  $f(\text{LASB}) = 9300$  MHz

4) Guard Band ( $f(1.5/T)$ ) :

Pulselength	Short	Middle	Long
Range Scale (nm)	0.25	2	36
Pulselength ( $\mu$ sec)	0.08	0.30	0.80
Guard Band $f(1.5/T)$ (MHz)	18.75	5.00	1.88

### 3.6.5 Test Results:

Shown on Fig. 3.6.2.

(1) "Upper Tolerance Frequency measured (at  $-20^\circ\text{C}$ )",  $f(\text{U}) = 9418.3$  MHz

(2) "Lower Tolerance Frequency measured (at  $+50^\circ\text{C}$ )",  $f(\text{L}) = 9404.1$  MHz

(3)-(a)

$f(\text{U}) + \text{max. } f(1.5/T) = 9437.04$  MHz  $< f(\text{UAUBW}) = 9460$  MHz  $\leq f(\text{UASB}) = 9500$  MHz

(3) - (b)

$f(\text{L}) - \text{max. } f(1.5/T) = 9385.32$  MHz  $> f(\text{LAUBW}) = 9360$  MHz  $\geq f(\text{LASB}) = 9300$  MHz

So, both are found within the specified limits.

### FREQUENCY STABILITY WITH VARIATION OF PRIMARY SUPPLY VOLTAGE:

The built-in voltage regulator allows no frequency variation against variations of  $\pm 15\%$  of nominal power supply voltage (20.4 to 27.6 VDC for nominal 24 VDC).

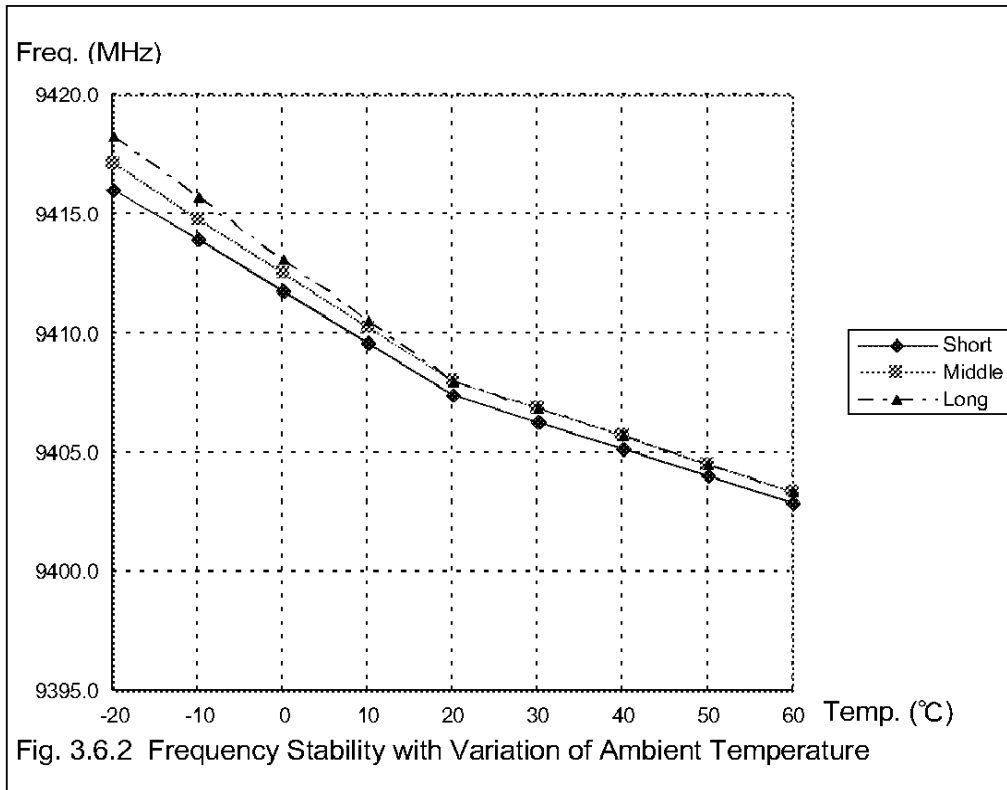

## 3.7 Suppression of Interference Aboard Ships (FCC Rule § 80.217)

### 3.7.1 Measuring Antenna Characteristics at Representative Frequencies:

Whip antennas are used to determine the level of interference caused by the radar to shipboard receivers. These antennas have the following characteristics (refer to impedance charts attached):

Length	Test Frequency (Hz)	Impedance ( $\Omega$ )	$\theta$	R ( $\Omega$ )	C or L
6 m	500.5 k	1 k	-90 °	0	80 pF
6 m	1.992 M	1.25 k	-86 °	87.2	64 pF
6 m	10.00204 M	158		109	140 pF
4 m	27.5 M	95		83.5	128 pF
5/8 _	150 M	116.5		105.5	52.5 nH
1/4 _	450 M	70.5		34.5	5.68 pF

**3.7.2 Test Site:** Rooftop of 6-story building,  
Furuno Electric Company, Ltd.  
Ashihara-cho 9-52, Nishinomiya-city, 662-8580 JAPAN

### 3.7.3 Measuring Instrument List:

See Attachment D [ List of Test/Measuring Equipment ].  
(Instruments for measuring antenna characteristics are listed below.)

- (1) Network Analyzer, HP 8753C
- (2) Spectrum Analyzer, ADVANTEST TR4172
- (3) Spectrum Analyzer, HP 8566B
- (4) Antennas,  
for 14 k - 10 MHz, 6 m whip  
for 10 - 30 MHz, 4 m whip  
for 30 - 300 MHz, VHF whip  
for 300 - 1000 MHz, UHF whip

### 3.7.4 Test Results:

Interference levels to the respective antenna were measured at 2 m from the radar which was put in OFF and TRANSMIT conditions, and found within the specified limits.

#### 3.7.4.1 Harmful Interference to Receiver (FCC Rule § 80.217 (a))

Limits: for 14 - 490 kHz, 5  $\mu\text{V/m}$   
for 490 kHz - 1 GHz, 1  $\mu\text{V/m}$

Results: There is no spurious component which is deemed harmful interference. (Test data are shown in Attachment C.)

#### 3.7.4.2 Electromagnetic Field (FCC Rule § 80.217 (b) - 1)

Limits: for below 30 MHz, 0.1  $\mu\text{V/m}$  at 1 nm (-20 dB $\mu\text{V/m}$ )  
for 30 to 100 MHz, 0.3  $\mu\text{V/m}$  at 1 nm (-10.5 dB $\mu\text{V/m}$ )  
for 100 to 300 MHz, 1.0  $\mu\text{V/m}$  at 1 nm (0 dB $\mu\text{V/m}$ )  
for over 300 MHz, 3.0  $\mu\text{V/m}$  at 1 nm (9.5 dB $\mu\text{V/m}$ )

Results: Interference was measured with the antenna located 2 m from the radar and converted to levels at 1 nm. There is no spurious component exceeding the limits.  
(Test data are shown in Attachment C.)

#### 3.7.4.3 Power Input to an Artificial Antenna (FCC Rule § 80.217 (b) - 2)

Limits: for below 30 MHz, 400  $\mu\text{W}$   
for 30 to 100 MHz, 4,000  $\mu\text{W}$   
for 100 to 300 MHz, 40,000  $\mu\text{W}$   
for over 300 MHz, 400,000  $\mu\text{W}$

Results: There is no spurious component exceeding the limits.  
(Test data are shown in Attachment C.)

## MEASUREMENT OF IMPEDANCE OF TEST ANTENNAS

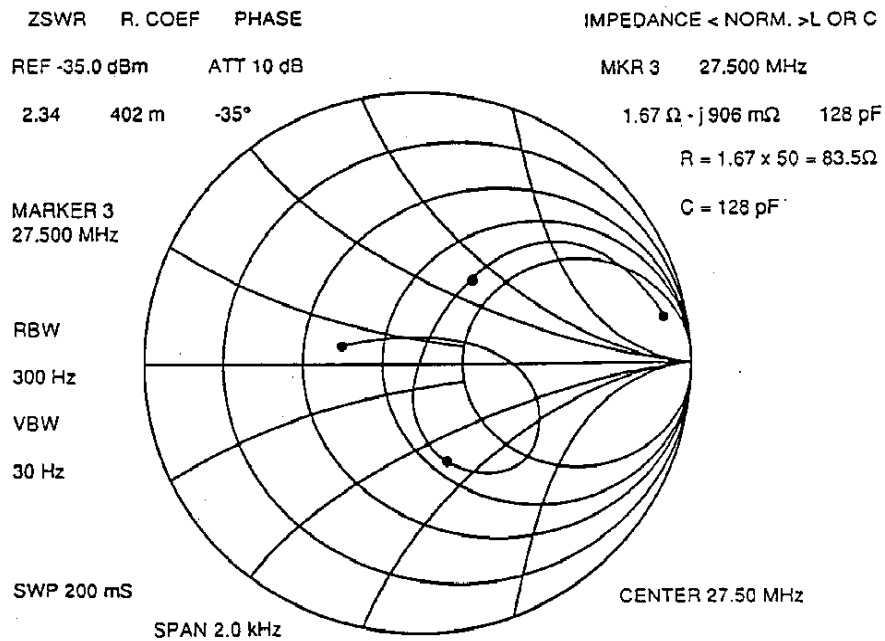
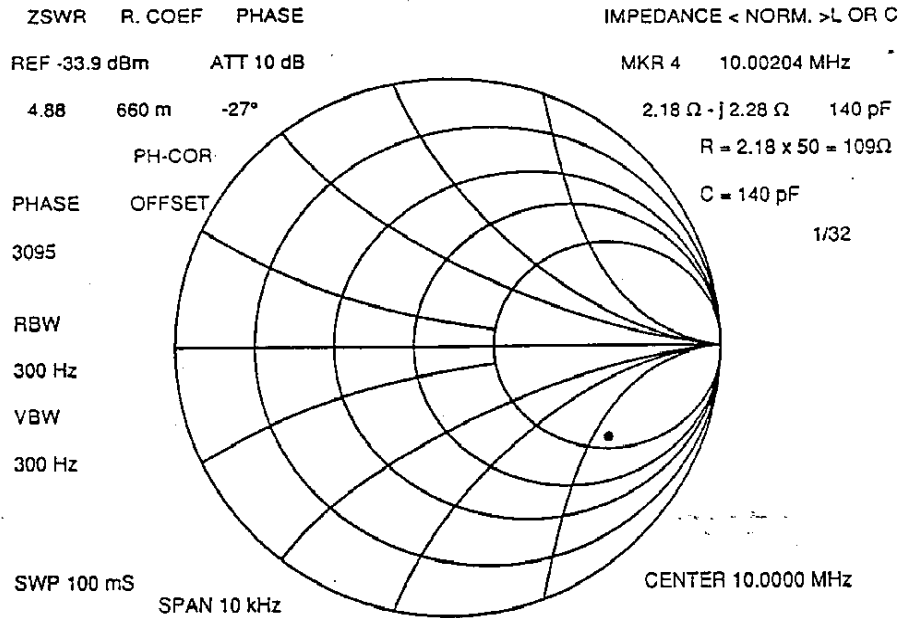

## MEASUREMENT OF IMPEDANCE OF TEST ANTENNAS

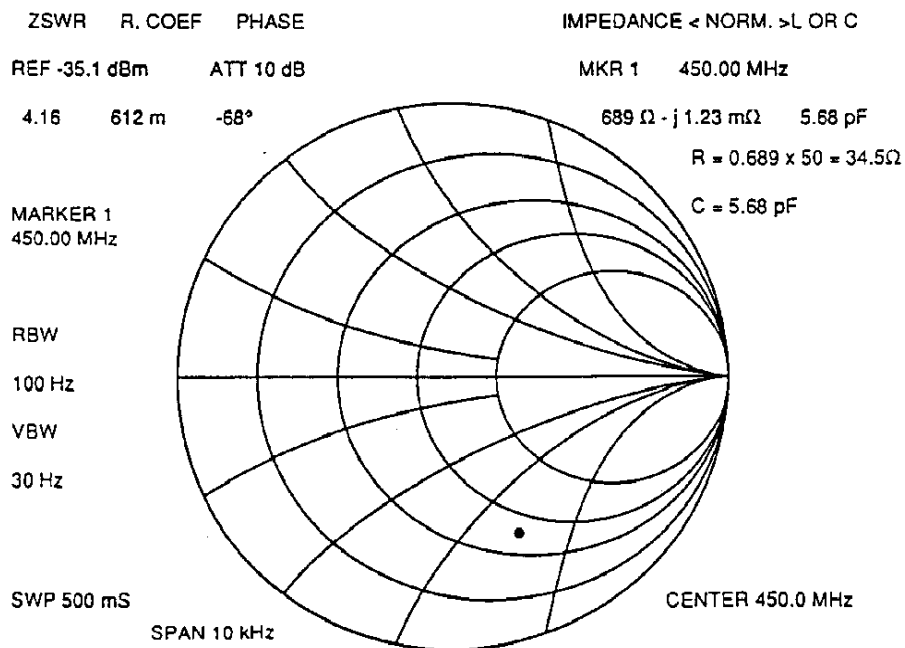
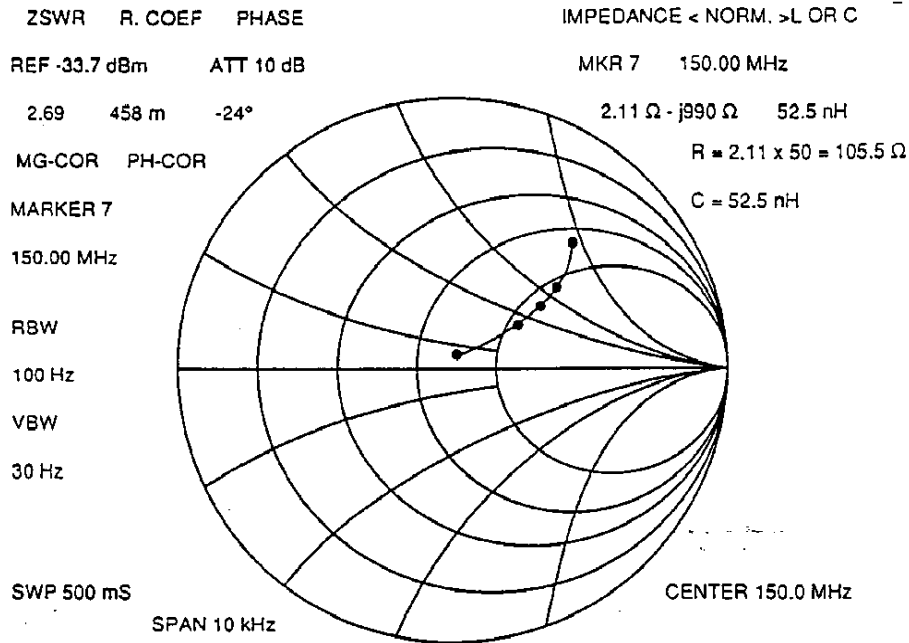



**4 Photographs to Reveal Equipment Construction and Layout (FCC Rule § 2.1033)**

(See Attachment E Photos of the Equipment Under Test (EUT))

## 5 Description of Circuitry and Devices (FCC Rules § 2.1033)

### 5.1 Function of Each Semiconductor or Active Device

#### ANTENNA UNIT

##### TRANSCEIVER MODULE (RTR-051)

###### MD Board (MD9052)

CR801 - CR802:	Rectifier
CR803 - CR804:	Transient Suppression
CR805:	Detector (Magnetron Current)
CR806:	Voltage Slicer
CR807:	Rectifier
CR808:	Pulse width Select
L801 - L803:	Noise Reject
Q801:	MOS FET Modulator
Q802:	90 kHz PWM Inverter and output MOS FET
Q803 - Q805:	Pulse Amplifier
Q806:	Pulse Width Select
T801:	Pulse Transformer
T802:	Transformer
U811:	Pulse Former
U812:	90 kHz PWM Inverter and output MOS FET

###### Chassis Mounted Parts

HY801:	3 Ports Circulator
U801:	MIC Frequency Converter with Limiter
V801:	Magnetron

###### IF Board (IF7758)

CR601:	PIN Attenuator
CR602:	Voltage Shifter
CR603 - CR605:	Band Switching
CR606:	Voltage Slicer (Ovrervoltage Protector)
CR607 - CR609:	Voltage Shifter
CR610:	Voltage Reference
CR611:	Band Switching
CR615:	Rectifier
CR616:	D.C. Blocking (STC)
CR617:	Rectifier
CR618:	D.C. Blocking (FTC)
CR619:	Voltage Shifter
CR625:	Variable Capacitance
CR630 - CR631:	Voltage Slicer (Overvoltage Protector)
Q601 - Q602:	IF Amplifier

Q603:	Amplifier (GAIN/STC)
Q604 - Q606:	Video Amplifier
Q610 - Q613:	Transistor Switch (STC/FTC Gate)
Q614 - Q615:	Transistor Switch (Band Switching)
T601 - T604:	Band Pass Filter
U601 - U602:	IF Amplifier
U603:	IF Amplifier (Tuning Indicator)
U604:	Voltage Regulator

INT PCB 03P8630

CR1:	Over-Voltage Protector
CR4 & CR7:	Reverse-Voltage Protector
CR8:	Voltage Slicer
Q3 - Q4:	Inverter
Q5:	Soft Starter
Q7:	Inverter
Q8:	Buffer
Q9 - Q10:	Inverter
U2:	Flip-Flop
U3 - U4:	Gate

## 5.2 Description of the circuits employed for suppression of spurious radiation, for limiting or shaping the control pulse, and for limiting or controlling power

### ANTENNA UNIT

TRANSCEIVER MODULE (RTR-051)

#### Modulator PCB MD9052

The primary function of the modulator is to produce narrow high-tension pulses to drive the magnetron. To produce such pulses, the modulator board incorporates a modulator trigger circuit, a modulating pulse generator and a booster pulse transformer.

The modulator trigger circuit is composed of U811 and associated components. It generates pulses that fire modulator FET Q801. Normally, the circuit is stable with U811 off. The pulse to fire the modulator FET is produced when U811 turns on upon receiving the TX trigger pulse from the display unit. When U811 turns on at the positive-going edge of the TX trigger pulse, it produces a narrow pulse. This narrow pulse is boosted by pulse transformer T802 by the ratio 1 :16. The resultant pulse, its level being 2.2 kV, is provided to limit the magnetron current.

CR803 and CR804 absorb the ringing in the secondary side of T801 while C807 decouples the pulse energy that is liable to occur across the magnetron heater when T801's secondary windings are unbalanced or the load is asymmetric.

Also incorporated in the modulator board are the TX HV circuit and magnetron heater power supply circuit. The TX HV circuit provides a high-tension of about 300 V to the pulse forming network through CR802 and CR807. A DC voltage of 8.0 V is supplied to the magnetron heater through CR801.

#### Duplexer and Frequency Converter (in Scanner unit)

The microwave energy produced by the magnetron enters the circulator from port 2. It is fed to port 3 with a negligible loss of energy; port 1 at this time is isolated. In the same manner, the received signal entering into port 3 is transferred to port 1, isolating port 2.

This operation of the circulator protects the receiver during transmission and minimizes the loss of the received signal. Thus, the circulator allows a single antenna radiator to be used for transmission and reception of radar signals.

A diode limiter, made up of a pair of PIN diodes, is incorporated in the first stage of the MIC (microwave IC, U801). It is a passive switching device which allows the low-level RF signal to pass through and prohibits relatively strong microwave energy, such as the leak from the magnetron. It also protects the sensitive amplifier from pulses received directly from other radars operating in the proximity.

When a low-level signal is received, the PIN diodes remain in the cutoff state, and the limiter's input impedance matches the characteristic impedance of the receiver allowing the signal to be delivered to the frequency converter of U801. When strong microwave energy is received, the PIN diodes are put in the conductive state (or short-circuited) causing the input energy to be attenuated. The strong input is further reduced to about 150 mW by the varacter diode.

The MIC converts 9 GHz RF signal into an intermediate frequency of 60 MHz. It is achieved by

mixing the received signal with the local oscillator signal in the frequency converter of the MIC. The built-in local oscillator oscillates at a frequency 60 MHz higher than the magnetron frequency of 9410 MHz.

## IF Amplifier Board IF7758

The detected 60 MHz IF signal is amplified by the RF amplifier, the output of which is delivered to the display unit video amplifier. The 60MHz IF signal from the MIC is fed to the base of Q601 through C601.

The signal from Q602 is fed to the broad band amplifier U601. The output of U601 is inductively coupled to the second-stage broad band amplifier U602.

GAIN/STC signals are applied respectively to U601 pin 16 and pin 13 via the STC circuit. The output of U602 is then coupled to video detector Q604. The video signal is taken from the emitter of Q605 through C632, and sent to the display via the video cable.

The IF amplifier PCB also incorporates an STC circuit. The STC circuit made up of Q610, Q611 and Q612 changes the gain of the IF amplifier in the function of time so that the gain is minimum at the time of transmission and increases gradually to maximum gain with time (range).

The amount of current flowing into Q612 is determined by the time constant of the parallel-series capacitor/ resistor network consisting of C641 - C643, R637 - R640. It gradually decreases as the capacitors are discharged. The rate of discharge is inversely proportional to "t", the elapsed time after transmission. The current flowing into Q612 is also controlled by the base potential in addition to the time constant of the capacitor/ resistor network.

The time-varying waveform produced at the emitter of Q612 is de-restored by the STC control potentiometer (located in the display) and applied to U601 pin 13.

**6 Operator's Manual Incl. Circuit Diagrams (FCC Rule § 2.1033)**

(See separate covers)