

Test report

99624530

based on:
Draft IEC 61097-6 Ed.2 (CDV) 02/2005
EN 61162-1

NAVTEX Receiver
Furuno
NX-700A; NX-700B

Contents

MAIN MODULE.....	5
1 INTRODUCTION	5
2 PRODUCT	6
3 TEST SCHEDULE	6
4 PRODUCT DOCUMENTATION.....	7
5 OBSERVATIONS AND COMMENTS	7
6 SUMMARY.....	7
7 CONCLUSIONS.....	8
TEST RESULTS MODULE	9
GENERAL INFORMATION	10
5 PERFORMANCE REQUIREMENTS	11
5.1 <i>Introduction</i>	11
5.2 <i>General characteristics</i>	11
5.3 <i>Specific characteristics</i>	12
5.3.1 <i>B1 and B2 Characters</i>	12
5.3.2 <i>B3 and B4 Characters</i>	12
5.3.3 <i>Preamble</i>	12
5.3.4 <i>Repetition of printing/display</i>	12
5.3.5 <i>Mandatory printing/display</i>	12
5.3.6 <i>Reception of messages with character errors</i>	12
5.3.7 <i>Controls and indicators</i>	13
5.3.8 <i>Programmable control memories</i>	13
5.3.9 <i>Alarms</i>	13
5.3.10 <i>Test facilities</i>	13
5.4 <i>Interfaces</i>	14
5.5 <i>Receiver</i>	14
5.5.1 <i>Number of receivers</i>	14
5.5.2 <i>Receive Frequencies</i>	14
5.5.3 <i>Sensitivity</i>	14
5.6 <i>Display</i>	14
5.6.1 <i>User Interface</i>	14
5.6.2 <i>Number of characters display per line</i>	15
5.6.3 <i>Number of lines displayed</i>	15
5.6.4 <i>Display requirements</i>	15
5.6.5 <i>Visibility of display</i>	15
5.6.6 <i>Automatic line feed</i>	15
5.6.7 <i>End of message display</i>	15
5.6.8 <i>Corrupt characters</i>	15
5.6.9 <i>Printer interface message selection requirements</i>	15
5.7 <i>Integral printer</i>	16
5.7.1 <i>Number of characters printed per line</i>	16
5.7.2 <i>Automatic line feed</i>	16
5.7.3 <i>End of message display</i>	16
5.7.4 <i>Corrupt characters</i>	16
5.7.5 <i>General printer requirements</i>	16
5.7.6 <i>Printer message selection requirements</i>	16
5.8 <i>Navtex message memory</i>	17
5.8.1 <i>Equipment without integral printers</i>	17
5.8.2 <i>Equipment with integral printer</i>	17
5.9 <i>Power Supplies</i>	18
5.10 <i>Durability and General Construction</i>	18

5.11	<i>Interference</i>	18
5.12	<i>Safety Precautions</i>	18
5.13	<i>Maintenance</i>	18
5.14	<i>Marking and Identification</i>	18
5.15	<i>Source of UTC</i>	18
6	TEST CONDITIONS	18
7	IEC 60945 TESTS REQUIRED	19
7.1	<i>Ergonomics and HMI</i>	19
7.1.1	General	19
7.1.2	Arrangement	19
7.1.3	Operation	19
7.1.4	Identification	19
7.1.5	Screen display and indicators	19
7.1.6	Voice announcement	19
7.1.7	Safety of operation	20
7.2	<i>Hardware</i>	20
7.2.1	General	20
7.2.2	Alarms and indicators	20
7.2.3	Illumination	20
7.3	<i>Software</i>	21
7.3.1	General	21
7.3.2	Monitoring	21
7.3.3	Operation	21
7.3.4	Inter-unit connection	21
7.4	<i>Power supply tests</i>	21
7.5	<i>Durability and resistance to environmental conditions</i>	21
7.6	<i>Electromagnetic emissions</i>	21
7.7	<i>Immunity to electromagnetic environment</i>	21
7.8	<i>EMC tests</i>	21
8	SERIAL INTERFACE TESTS	22
8.1	<i>INS input electrical tests</i>	22
8.2	<i>INS input performance tests</i>	22
8.3	<i>INS output electrical tests</i>	22
8.4	<i>INS output performance tests</i>	22
8.5	<i>Printer output electrical tests</i>	22
8.6	<i>Printer output performance tests</i>	22
9	GENERAL & SIGNAL PROCESSING TESTS	23
9.1	<i>Exclusion of stations</i>	23
9.2	<i>Exclusion of message categories</i>	23
9.3	<i>Receiver test facility</i>	23
9.4	<i>SAR alarm provision and reset</i>	23
9.5	<i>Additional alarms</i>	23
10	RECEIVER TESTS	24
10.1	<i>Call sensitivity</i>	24
10.2	<i>Interference rejection and blocking immunity</i>	26
10.3	<i>Co-channel rejection</i>	27
10.4	<i>Intermodulation</i>	28
10.5	<i>Off frequency transmitter</i>	29
10.6	<i>Simultaneous operation on several receive frequencies</i>	29
10.7	<i>Protection of input circuits</i>	30
11	PRINTER TESTS	31
11.1	<i>Basic requirements</i>	31
11.2	<i>Paper roll end alarm and storage inhibition</i>	31
11.3	<i>Automatic line-feed indication and paper feed</i>	31
11.4	<i>Mutilated character indication</i>	31
11.5	<i>Tests of technical characteristics (ITU-R Rec. M.540)</i>	31

11.5.1	B1/B2 characters selection.....	31
11.5.2	Printer activation/error-free preamble B1-B4	31
11.5.3	Non-repetitive printing of a message	31
11.5.4	Message with B3B4 = 00.....	31
12	MEMORY TESTS.....	32
12.1	<i>Internal storage, message tagging, erasure of oldest msg ID</i>	32
12.2	<i>Erasure of message identifications/storage time</i>	32
12.3	<i>Storage of message identifications</i>	33
12.4	<i>Reception of messages with character errors</i>	33
12.5	<i>Unsatisfactory reception</i>	33
12.6	<i>Power-off check</i>	33
12.7	<i>Brown-out test</i>	33
12.8	<i>UTC handling check</i>	34
13	MISCELLANEOUS TESTS	35
13.1	<i>Spurious emissions</i>	35
13.2	<i>Special purpose and safety tests</i>	35
13.3	<i>Maintenance</i>	35
13.4	<i>Equipment manuals – check of manufacturer’s documentation</i>	35
13.5	<i>Marking and identification</i>	35
	USED TEST EQUIPMENT MODULE	36

This report comprises of three modules. The total number of pages is: 36.

Main module

1 Introduction

This report contains the result of tests conducted by:

Telefication bv
Edisonstraat 12a
6902 PK Zevenaar
The Netherlands

Telefication complies with the accreditation criteria for test laboratories as laid down in ISO/IEC 17025:1999. The accreditation covers the quality system of the laboratory as well as the specific activities as described in the authorized annex bearing the accreditation number L021 and is granted on 30 November 1990 by the Dutch Council For Accreditation (RvA: Raad voor Accreditatie). The copyright of this test report is owned by Telefication bv and may not be reproduced except in full without the written approval of Telefication bv.

Ordering party:

Company name : Furuno Electric Co., Ltd.
Address : 9-52 Ashihara-cho
Zipcode : 662-8580
City/town : Nishinomiya
Country : Japan
Date of order : 15 March 2005

2 Product

A sample of the following product was submitted for testing:

Product category	: NAVTEX Receiver
Manufacturer	: Furuno Electric Co., Ltd.
Trade mark	: Furuno
Type designation	: NX-700A; NX-700B
Hardware parts	: NX-700 (A/B); NX-7001; NX-7H
Software release	: Prog.: 0850193-01; Boot: 0850192-01
Serial number	: NX-700A: 8523-0001 (RX unit); 00001 (display unit) NX-700B: 8524-0001 (RX unit); 00001 (display unit)

3 Test schedule

Tests were carried out in accordance with the specification detailed in chapter "Summary" of this report.

Tests were carried out at the following location:

- R&D department Furuno Electric Co., Ltd., Nishinomiya, Japan

The sample of the product was received on:

- n.a.

Tests were carried out from:

- 18 April 2005 to 22 April 2005
-

4 Product documentation

For production of this report the following product documentation was used:

Description:	Date:	Identification:
Operator's Manual	20 May 2005	OME-56490
Installation Manual	--	Included in OME-56490
System Config., schematics	18 May 2005	KT55-013
Photograph File	12 May 2005	FLI 01-05-010

The above-mentioned documentation will be filed at Telefication for a period of 10 years following the issue of this report.

5 Observations and comments

Navtex receiver on 518 kHz and additional receiver on 490 kHz or 4209.5 kHz.

Although not required, receiver performance tests according to clause 10.2 and 10.4. also have been performed with the active ferrite loop antenna included in the signal path.

The storage time until deletion of messages has been declared by the manufacturer to be 66 hours.

Compliance to the utilized specification Draft IEC 61097-6 Ed. 2 (CDV) consequently ascertains compliance to IEC 61097-6 Ed. 1 or EN 300 065 V1.3.1 as well.

Photographs of the equipment are presented in the separate document:

FLI 01-05-010, dated 12 May 2005.

For all references to specification EN 60945 made in this report, refer to test report:

FLI 12-05-020, dated 17 May 2005.

6 Summary

The product is intended for use in the following application area:

Global Maritime distress and safety system (GMDSS)

The sample was tested according to the following specifications:

Draft IEC 61097-6 Ed.2 (CDV) 02/2005

EN 61162-1 July 2000

EN 61162-2 September 1998

7 Conclusions

The sample of the product showed **NO NON-COMPLIANCES** to the specifications stated in the summary of this report.

The results of the tests as stated in this report, are exclusively applicable to the product item as identified in this report. Telefication does not accept any responsibility for the results stated in this report, with respect to the properties of product items not involved in these tests.

All tests are conducted by:

name : M.W. Jansen

function : Senior Engineer Maritime

signature :

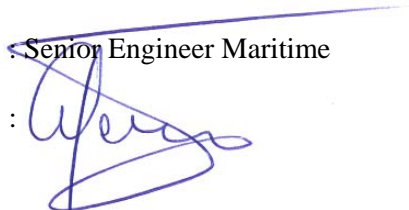

Review of test methods and report by:

name : ing. P.A. Suringa

function : Senior Engineer Radio/EMC

signature :

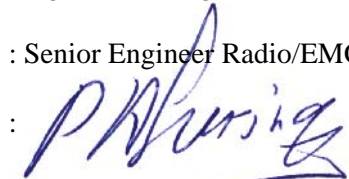

The above conclusions have been verified by the following signatory.

date :25 May 2005

name : J.P. van de Poll

function : Co-ordinator Test group

signature :

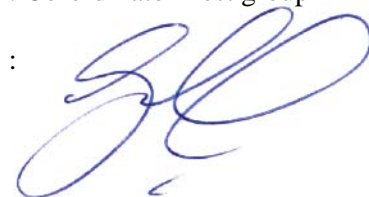

Test results module

General information

Equipment information

Equipment series no.	NX-700A; NX-700B
Type of equipment	Navtex Receiver operating simultaneously on 518 kHz and 490 kHz / 4209.5 kHz
NX-700A	Display unit with integral printer
NX-700B	Display unit without printer
NX-7001	Receiver unit
NX-7H	Active ferrite loop antenna
AC Power supply	PR-240-CE

5 PERFORMANCE REQUIREMENTS

5.1 Introduction

5.2 General characteristics

Satisfactory:

Complies with:

Navtex equipment Resolution MSC 148(77)	yes
IMO Res. A.694(17)	yes
ITU-R Rec. M625, annex I,4 collective B-mode	yes
ITU-R Rec. M540, annex II,3	yes
IEC 61162-1/-2 on digital interfaces	yes
Tested and compliant with IEC 60945	yes
Connection to integrated navigation system (INS)	yes

5.3 Specific characteristics

Satisfactory:

5.3.1 B1 and B2 Characters

Rejection of unwanted station ID (B1 character) yes

Disabling of message types – except A, B, D and L (B2 character) yes

Clear indication to user which B1 and B2 are disabled yes

5.3.2 B3 and B4 Characters

Two character serial number starting with 01 and special message with 00 yes

5.3.3 Preamble

Storage of message only when B1B2B3B4 is error free received yes

5.3.4 Repetition of printing/display

Prevention of storage or printing of already satisfactorily received messages yes

5.3.5 Mandatory printing/display

A B3B4=00 message shall always be printed stored and displayed yes

5.3.6 Reception of messages with character errors

5.3.6.1 Print/display messages with character error rate of < 33% yes

5.3.6.2 No print/store of messages with character error rate of > 33% yes

5.3.7 Controls and indicators

Satisfactory:

Details of (excluded) coverage areas and message categories readily available	yes
At least 4 message categories can be excluded, except A, B, D and L	yes
Number of controls enable simple, quick and effective operation	yes
Minimum chance of inadvertent operation	yes
Operational controls are easily operated and permit easy performance	yes
Controls not required for normal operation are not readily accessible	yes
Adequate illumination to facilitate reading at all times	yes
Dimming of any equipment's light source	yes
Misuse of controls do not cause damage to equipment or injury to personnel	yes
When connected to other units performance of each is maintained	yes
Digital input panel (0-9) according to ITU-T or ISO standard	n.a.

5.3.8 Programmable control memories

B1 and B2 designators are permanently stored in non-volatile memory	yes
---	-----

5.3.9 Alarms

Reception of B2 = D gives alarm at ships navigation position	yes
Manual reset of this alarm only	yes
Equipment contains integral alarm sounder	yes
Equipment facilitates a pair of relay contacts for external sounder	yes
Availability of additional alarms	yes
Provision to suppress these alarms	yes
Additional alarm distinguishable from SAR alarm	yes
Audible volume 75-85 dBA (<i>refer to clause 9.4</i>)	yes
Relay contacts for external sounder is free of earth	yes
Alarm condition is reported via ALR command on INS port	yes

5.3.10 Test facilities

Provision for testing the radio receiver, display, printer and message memory	yes
---	-----

5.4 Interfaces

Satisfactory:

Equipment includes interface of transfer to Nav. And Comm. Equipment	yes
Interface complies with IEC 61162 (EN 61162-1)	yes
When no integral printer, interface for standard printed facilitated	yes
Support of new IEC 61162 sentences for interface to INS	yes

5.5 Receiver

5.5.1 Number of receivers

Equipment includes first receiver for international NAVTEX system 518 kHz	yes
At least one other receiver operating at least on two other frequencies	yes
Second receiver is capable of simultaneous operation	yes
518 kHz receiver has priority on the display or printing of received information	yes
Printing or displaying of messages shall not prevent reception by other receiver	yes

5.5.2 Receive Frequencies

The recognized receive frequencies shall be 518 kHz, 490 kHz and 4209.5 kHz	yes
Switching frequencies of second receiver by INS port or manually	yes

5.5.3 Sensitivity

Receiver sensitivity shall be 2uV EMF (-107 dBm) at error rate < 4 % <i>Results (see clause 10.1)</i>	yes
--	-----

5.6 Display

If a display is included as part of the equipment the following is applicable:

5.6.1 User Interface

A display mode showing selected coverage area (B1) and message types (B2)	yes
Adjustment for setting of display illumination and contrast	yes
Indication of which receiver(s) is currently receiving	yes
New SAR messages shall be displayed immediately, stored and cause alarm	yes
SAR messages shall be displayed until acknowledged by alarm cancellation	yes
Reception and storage of new messages shall be clearly indicated	yes
Independent selection of B1 and B2 for either storage, printing and INS output	yes

Satisfactory:

5.6.2 Number of characters display per line

The display shall be able to display a minimum of 32 characters per line *yes*

5.6.3 Number of lines displayed

The display shall be able to display at least 16 lines of message text *yes*

5.6.4 Display requirements

Indication of newly received messages shall be immediately displayed *yes*

Displayed indication remains until acknowledged or until 24 hours after receipt *yes*

Newly received message shall also be capable of being displayed *yes*

5.6.5 Visibility of display

Display information easily read under all normal working conditions *yes*
(applies to information from any receiver, in any language and supported alphabet)

5.6.6 Automatic line feed

Automatic line feed entailing a word shall be indicated in the displayed text *yes*

5.6.7 End of message display

Clear indication of end-of-message by automatic adding line feeds or other *yes*

5.6.8 Corrupt characters

Corrupt characters are displayed as an asterisk (*) *yes*

5.6.9 Printer interface message selection requirements

When no printer is integrated, the following must be sent to the printer interface:

a) all messages as they are received *yes*

b) all messages stored in memory *yes*

c) messages received on specific frequencies, from specific B1, with specific B2 *yes*

d) all currently displayed messages *yes*

e) individual selected messages *yes*

Satisfactory:

5.7 Integral printer

If a printer is included as part of the equipment the following is applicable:

5.7.1 Number of characters printed per line

The printer shall be able to display a minimum of 32 characters per line yes

5.7.2 Automatic line feed

Automatic line feed entailing a word shall be indicated in the printed text yes

5.7.3 End of message display

Indication of end-of-message print by automatic inserting line feeds yes

5.7.4 Corrupt characters

Corrupt characters are printed as an asterisk (*) yes

5.7.5 General printer requirements

- a) print easy legible signs yes
- b) acoustic noise production < 60dBA (*see clause 11.1*) yes
- c) run-out or nearly run-out paper alarm yes
- d) temporarily storage of partially printed messages yes
 - message printed once new paper loaded yes
 - storage of further new message ID's inhibited when no paper loaded yes

5.7.6 Printer message selection requirements

Selectable data to be output to the integral printer:

- a) all messages as they are received yes
 - b) all messages received on specific frequencies, from specific B1, with specific B2 yes
-

5.8 Navtex message memory

Satisfactory:

5.8.1 Equipment without integral printers

5.8.1.1 Number of messages

For each receiver at least 200 messages (avg. length 500 char.) *yes*

Not possible to erase messages by user *yes*

When memory is full, oldest message shall be overwritten *yes*

5.8.1.2 Message tagging

Permanent retention by user selectable tagging *yes*

Tagged messages may occupy 50 of the 200 message slots *yes*

Tagged messages may not be overwritten *yes*

Tags shall be user removable *yes*

5.8.1.3 Automatic erasure

Automatic erasure of message (and ID) (if not tagged) after 60 to 72 hours *yes*

If memory capacity is exceeded, oldest message shall be erased *yes*

5.8.2 Equipment with integral printer

5.8.2.1 Number of messages

The equipment shall store at least 200 message ID's *yes*

5.8.2.2 Automatic erasure

Automatic erasure of message ID's after 60 to 72 hours *yes*

If memory capacity is exceeded, oldest message ID shall be erased *yes*

5.9 Power Supplies

See EN 60945 test report

5.10 Durability and General Construction

See EN 60945 test report

5.11 Interference

See EN 60945 test report

5.12 Safety Precautions

See EN 60945 test report

5.13 Maintenance

See EN 60945 test report

5.14 Marking and Identification

See EN 60945 test report

5.15 Source of UTC

UTC is being obtained by the equipment externally with an internal backup

6 Test Conditions

Refer to chapter 6 of the standard

7 IEC 60945 Tests required

Satisfactory:

7.1 Ergonomics and HMI

7.1.1 General

All required modes of operation are available yes

7.1.2 Arrangement

Operational controls provide simple, quick and efficient operation yes

Control indicators are readily distinguishable yes

7.1.3 Operation

Arrangement of controls minimises incorrect operation yes

Controls not for normal operation are not readily accessible yes

Controls are related to function and environment yes

7.1.4 Identification

Operational controls and indicators comply with marking requirements yes

Indicator character-type is simple and clear yes

Character height > 3.5mm and character width is 0.7 * height yes

Controls and indicators are identified in English language yes

7.1.5 Screen display and indicators

Illumination of display and indicators is dimmable and can be switched-off yes

Alternatively a night mode of display operation may be provided n.a

Display contrast is adjustable *manually* yes

Display and indicators are clearly visible over temperature range yes

7.1.6 Voice announcement

Not applicable.

Satisfactory:

7.1.7 Safety of operation

Irreversible actions require confirmation before proceeding	yes
Equipment utilizes quality indication contained in input from other sources	yes
INS input port requires all sentences contain valid checksum	yes
INS output port generates all sentences with valid checksum	yes

7.2 Hardware

7.2.1 General

Blocking off of controls or facilities not fitted	n.a.
Protection against unintentional operation	yes
Misuse of controls do not cause damage to equipment or personnel	yes

7.2.2 Alarms and indicators

Facilities for self test and indication of result of this test	yes
Alarm indications are highlighted on the display or remote red indicator	yes
Warning and alarm indicators show no self illumination	yes
Indirect illumination is low to avoid false indications	yes

7.2.3 Illumination

Illumination is adequate for operation under all expected conditions	yes
Illumination is adjustable for night use	yes
Provision of dimming of any equipment's light source	yes
Warning and alarm lamps cannot be dimmed below reading intensity	yes
Illumination is dazzle-free	yes
Illumination adjustable to extinction except warning and alarm lamps	yes
Not illuminated controls are easily locatable by tactile means	n.a.
Information presented with high contrast on low reflectance background	yes
Transparent covers do not cause reflections reducing readability	yes
Provision of dimmer function for all lamps used for ambient illumination	yes

7.3 Software

7.3.1 General

See EN 60945 test report

7.3.2 Monitoring

See EN 60945 test report

7.3.3 Operation

See EN 60945 test report

7.3.4 Inter-unit connection

See EN 60945 test report

7.4 Power supply tests

See EN 60945 test report

7.5 Durability and resistance to environmental conditions

See EN 60945 test report

7.6 Electromagnetic emissions

See EN 60945 test report

7.7 Immunity to electromagnetic environment

See EN 60945 test report

7.8 EMC tests

See EN 60945 test report

8 Serial Interface Tests

Satisfactory:

8.1 INS input electrical tests

The interface complies with the applicable requirements of IEC 61162-1/2 *yes*

8.2 INS input performance tests

Performance of INS input is not inhibited by invalid or unavailable data formatters *yes*

Correct operation during 5 minutes 100 % load of the interface *yes*

Displayed data or equipment operation agrees with simulated input data *yes*

8.3 INS output electrical tests

The interface complies with the applicable requirements of IEC 61162-1/-2 *yes*

8.4 INS output performance tests

Correct operation during 100 % load of the interface *yes*

Output data or equipment operation agrees with requested output data *yes*

8.5 Printer output electrical tests

The printer output complies with the applicable requirements of RS-232 *yes*

8.6 Printer output performance tests

Correct operation during 100 % load of the interface capacity *yes*

Output data or equipment operation agrees with requested output data *yes*

9 General & Signal Processing Tests

Satisfactory:

9.1 Exclusion of stations

Messages from not selected stations (B1) are neither displayed nor printed yes

9.2 Exclusion of message categories

Messages with not selected categories (B2) are neither displayed or printed yes
Category A, B, D and L cannot be de-selected and is always displayed or printed yes

9.3 Receiver test facility

Test message is being displayed or printed with indication pass/fail yes
Test message contains at least 36 valid characters yes
The test message is being displayed/printed but not stored yes

9.4 SAR alarm provision and reset

Alarm is activated when message with B2=D has been received yes
Alarm can be reset manually (*push any key*) yes
Alarm can be reset via 61162-ACK-sentence yes
Level of audible alarm is 75-85 dBA (*measured: 84 dBA @ 1 m*) yes

9.5 Additional alarms

Additional alarms are available yes
The additional alarm can be suppressed yes
The additional alarm can be reset yes

10 Receiver Tests

10.1 Call sensitivity

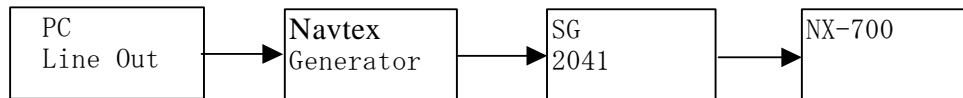

TEST CONDITIONS		SENSITIVITY LEVEL (dBm @ CER%)		
		518 kHz	490 kHz	4209.5 kHz
Temperature	Voltage	RF level (dBm)	RF level (dBm)	RF level (dBm)
<i>T_{nom}</i> (+15 – 35 °C)	<i>V_{nom}</i> (24.0 V)	- 119 @ 0 %	- 117 @ 0 %	- 115 @ 0 %
<i>T_{min}</i> (-15 °C)	<i>V_{min}</i> (10.8 V)	- 119 @ 0 %	- 117 @ 0 %	- 115 @ 0 %
<i>T_{min}</i> (-15 °C)	<i>V_{max}</i> (31.2 V)	- 119 @ 0 %	- 117 @ 0 %	- 115 @ 0 %
<i>T_{max}</i> (+55 °C)	<i>V_{min}</i> (10.8 V)	- 119 @ 0 %	- 117 @ 0 %	- 115 @ 0 %
<i>T_{max}</i> (+55 °C)	<i>V_{max}</i> (31.2 V)	- 119 @ 0 %	- 117 @ 0 %	- 115 @ 0 %
Measurement uncertainty		±1.2 dB		
Limits		≤ - 107 dBm @ < 4 % CER under normal test conditions, ≤ - 107 dBm @ < 4 % CER under extreme test conditions,		

Determination of antenna gain and substitution levels for active antenna measurements

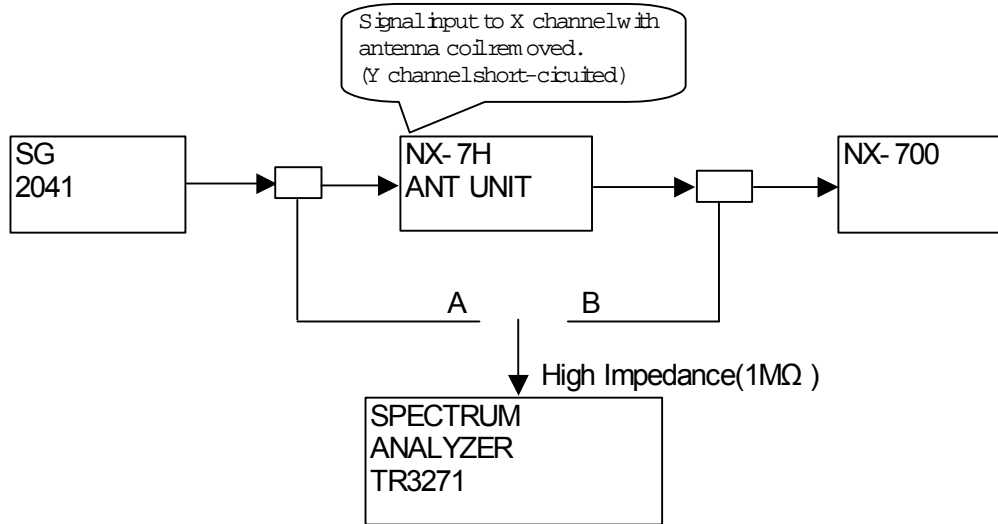

Frequency	A	B	ANT GAIN
490 kHz	-40dBm	-30.6dBm	+9.4dB
518 kHz	-40dBm	-30.5dBm	+9.5dB
4209.5 kHz	-40dBm	-21dBm	+19dB

10.2 Interference rejection and blocking immunity

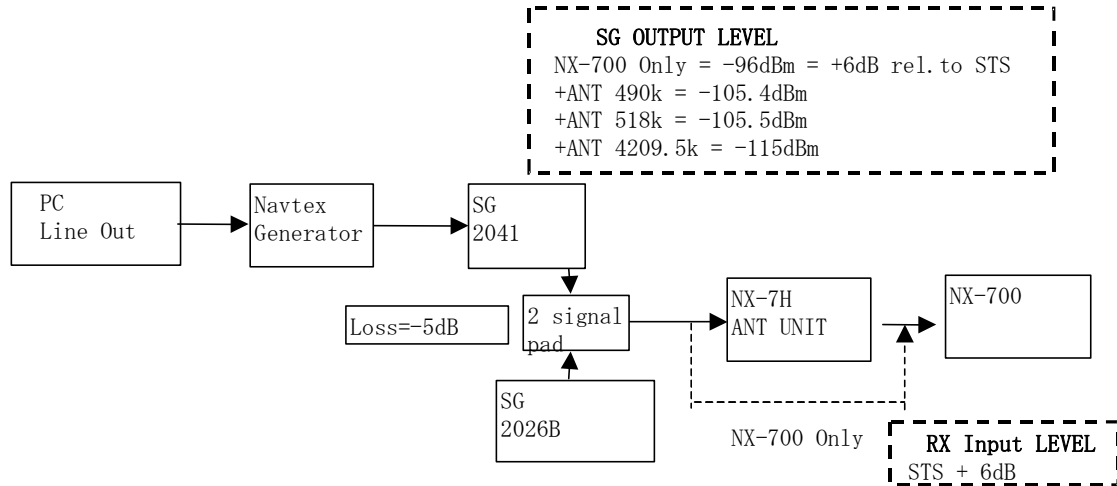

490 kHz					
Frequency band	NX-700 Only		+ANT		Limit
489-489.5kHz	54dB		54dB		>20dB
490.5-491kHz	52dB		53dB		>20dB
487-489kHz	85dB		84dB		>40dB
491-493kHz	89dB		90dB		>40dB
100-487kHz	90dB		90dB		>70dB
493kHz-30MHz	91dB		90dB		>70dB
156-174MHz	99dB		101dB		>70dB
450-470MHz	98dB		101dB		>70dB
518 kHz					
Frequency band	NX-700 Only		+ANT		Limit
517-517.5kHz	55dB		55dB		>20dB
518.5-519kHz	55dB		54dB		>20dB
515-517kHz	83dB		84dB		>40dB
519-521kHz	90dB		91dB		>40dB
100-515kHz	88dB		89dB		>70dB
521kHz-30MHz	90dB		89dB		>70dB
156-174MHz	95dB		101dB		>70dB
450-470MHz	96dB		102dB		>70dB
4209.5 kHz					
Frequency band	NX-700 Only		+ANT		Limit
4208.5-4209.0kHz	57dB		56dB		>20dB
4210.0-4210.5kHz	52dB		50dB		>20dB
4206.5-4208.5kHz	89dB		87dB		>40dB
4210.5-4212.5kHz	89dB		87dB		>40dB
100-4206.5kHz	90dB		87dB		>70dB
4212.5kHz-30MHz	89dB		86dB		>70dB
156-174MHz	114dB		119dB		>70dB
450-470MHz	116dB		119dB		>70dB
IF (490kHz)	75dB		95dB		>70dB
IF-2xIF (3229.5kHz)	87dB		96dB		>70dB

Levels are obtained at a CER < 4 %; measurement uncertainty: ±2.9 dB

10.3 Co-channel rejection

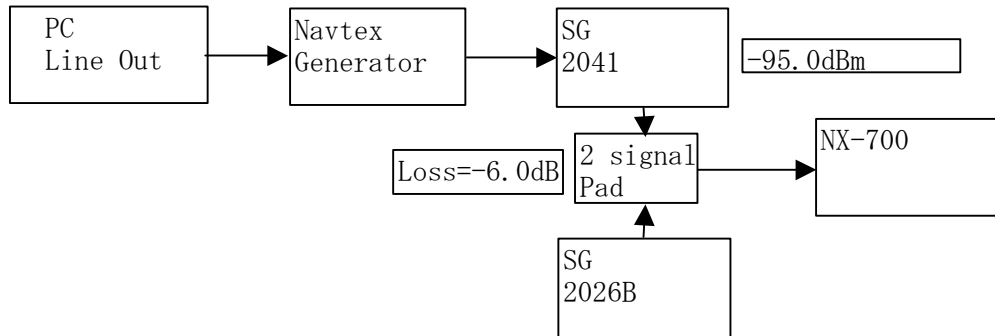

Frequency (kHz)	Rejection ratio (dB)	CER (%)	Limit: CER (%)
518	- 2.5	0	< 4
490	- 2.5	0	< 4
4209.5	- 2.5	0	< 4

Measurement uncertainty: ± 1.6 dB

CER: Character Error Rate

10.4 Intermodulation

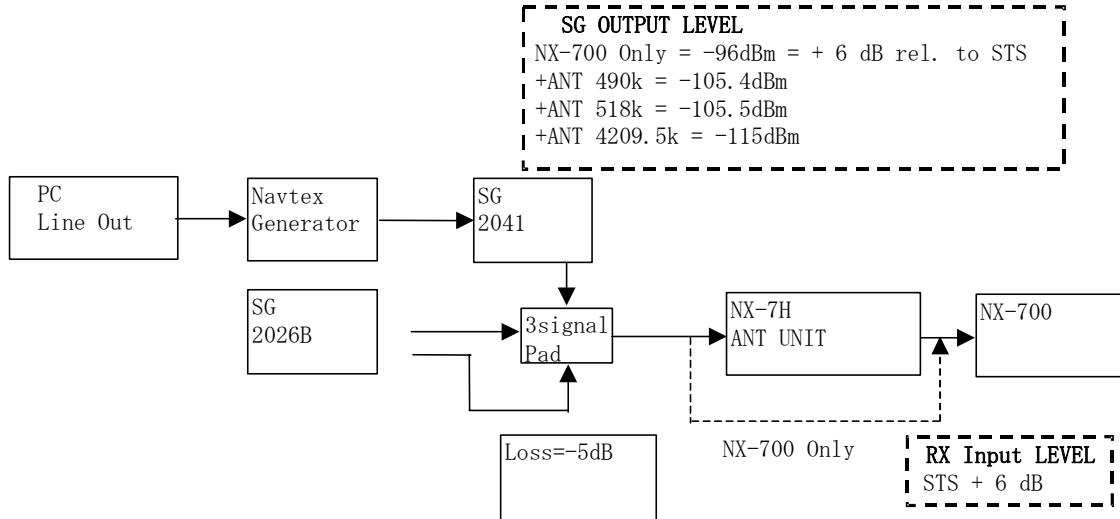

490 kHz	NX-700 Only	+ANT		Limit
488+486kHz	77dB		74dB	>70dB
487+484kHz	77dB		74dB	>70dB
486+482kHz	77dB		74dB	>70dB
492+494kHz	76dB		74dB	>70dB
493+496kHz	76dB		74dB	>70dB
494+498kHz	77dB		74dB	>70dB
518 kHz	NX-700 Only	+ANT		Limit
516+514kHz	77dB		74dB	>70dB
515+512kHz	76dB		74dB	>70dB
514+510kHz	77dB		74dB	>70dB
520+522kHz	76dB		73dB	>70dB
521+524kHz	76dB		74dB	>70dB
522+526kHz	77dB		74dB	>70dB
4209.5 kHz	NX-700 Only	+ANT		Limit
4207.5+4205.5kHz	73dB		71dB	>70dB
4206.5+4203.5kHz	73dB		72dB	>70dB
4205.5+4201.5kHz	73dB		72dB	>70dB
4211.5+4213.5kHz	72dB		71dB	>70dB
4212.5+4215.5kHz	72dB		72dB	>70dB
4213.5+4217.5kHz	72dB		71dB	>70dB

The intermodulation rejection values are obtained at a CER of < 4 %.
Measurement uncertainty: ±2.9 dB
CER: Character Error Rate

10.5 Off frequency transmitter

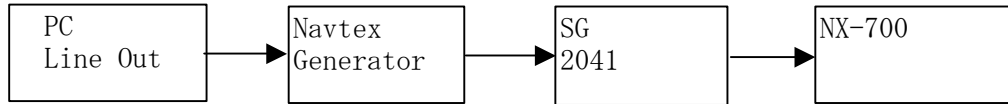

Frequency (kHz)	Frequency offset (Hz)	CER (%)	Limit: CER (%)
518	+50 / -65	0	< 4 @ 25 Hz offset
490	+50 / -60	0	< 4 @ 25 Hz offset
4209.5	+50 / -60	0	< 4 @ 25 Hz offset

Measurement uncertainty frequency offset: ± 0.1 Hz
CER: Character Error Rate

10.6 Simultaneous operation on several receive frequencies

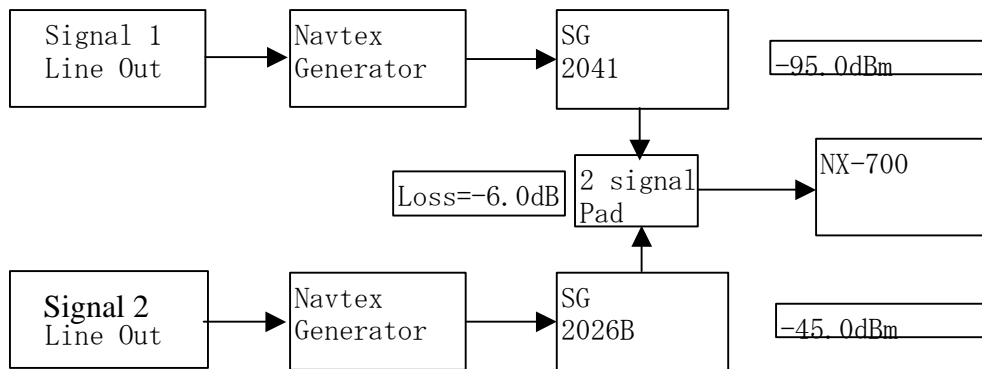

Test script:	Frequency (kHz)	Level: (dBm)	CER (%)	Limit: CER (%)
Signal 1 (A)	518	-101	0	< 4
Signal 2 (A)	490	-51	0	< 4
Signal 1 (B)	518	-101	0	< 4
Signal 2 (B)	4209.5	-51	0	< 4
Signal 1 (C)	490	-101	0	< 4
Signal 2 (C)	518	-51	0	< 4
Signal 1 (D)	4209.5	-101	0	< 4
Signal 2 (D)	518	-51	0	< 4

CER: Character Error Rate

10.7 Protection of input circuits

Protection of input circuits 30Vrms for 15 minutes	
Test frequency (kHz)	Correct operation after test
4350	yes
8250	yes
16850	yes
22250	yes

11 Printer Tests

Satisfactory:

11.1 Basic requirements

Minimum paper roll capacity of 200 000 characters *yes*
Calculated capacity: 274272 characters
Print-out has 32 easily legible characters per line *yes*
Acoustic noise of the printer < 60 dBA @ 1 meter *yes*
Measured: 49 dBA

11.2 Paper roll end alarm and storage inhibition

Paper-alarm shall be activated when paper is running out *yes*
Equipment stores and prints out on new paper all meantime received messages *yes*

11.3 Automatic line-feed indication and paper feed

A division of a word by automatic line feed is indicated in the print-out *yes*
Two line feeds are inserted at end of the message *yes*

11.4 Mutilated character indication

The print-out shall contain an asterisk (*) for each mutilated character *yes*

11.5 Tests of technical characteristics (ITU-R Rec. M.540)

11.5.1 B1/B2 characters selection

Messages from not selected stations (B1) are neither displayed nor printed *yes*
Messages with not selected categories (B2) are neither displayed nor printed *yes*
Category A, B, D and L cannot be de-selected and is always displayed or printed *yes*

11.5.2 Printer activation/error-free preamble B1-B4

No storage or print-out of messages with errors in preamble (B1, B2, B3 or B4) *yes*

11.5.3 Non-repetitive printing of a message

This test is covered by section 12.3

11.5.4 Message with B3B4 = 00

Messages with B3B4=00 are always printed (selected or non-selected) *yes*

12 Memory Tests

Satisfactory:

12.1 Internal storage, message tagging, erasure of oldest msg ID

This test is required for equipment not fitted with an integral printer

Required test script:

- a) - Message memory is 100 % pre-loaded with STF
- b) - 5 oldest messages tagged for permanent retention
- c) - 10 unique messages are sent to equipment
- d) - Tagged messages are untagged and 10 new unique messages sent

Results of above script:

The equipment indicates that all messages have been stored (a)	yes
The equipment has correctly tagged the messages (b)	yes
Indication that 5 (oldest) tagged messages are still stored (c)	yes
Indication that next 10 oldest messages are no longer stored (c)	yes
Indication that 10 oldest messages have been replaced by 10 new messages (d)	yes

12.2 Erasure of message identifications/storage time

This test is required for equipment not fitted with an integral printer

Required test script:

After test according to clause 12.1, wait 59 hours;
Send one message with message ID previously used and currently stored;
Tag another previously used message (B) for permanent retention;
Wait 2 hours, send a new unique message (A); wait 12 hours;
Apply test script of clause 12.1 with previously used message ID's

Results of above test script:

Indication that message applied after 59 hours was not stored	yes
Indication that this message did not overwrite any stored contents	yes
Indication that message A was stored and overwrote oldest stored message	yes
Indication that after 73 hours only message A and tagged message (B) are stored	yes
After application of test script of clause 12.1, store contains only this test script and the tagged message B	yes

Satisfactory:

12.3 Storage of message identifications

This test is required only for equipment fitted with an integral printer

Required test script:

Character error rate of the messages is < 4%;

35 messages with unique message ID are sent; wait 59 hours;

Send one message with message ID previously used and currently stored;

Wait 2 hours, send a new unique message (A); wait 12 hours;

Resend the 35 messages with previously used message ID's

Results of above test script:

Print-out shows character error rate of < 4% and message ID's are stored yes

Indication that message applied after 59 hours was not stored yes

Indication that this message did not overwrite any stored contents yes

Indication that message A was stored and overwrote oldest stored message yes

Indication that after 73 hours only message A is stored yes

Re-application of this test script, store contains only this test script and message A yes

12.4 Reception of messages with character errors

This test is required for all equipment

The equipment shall store/print messages indicating CER >20 % to ≤ 33 % yes

The equipment shall store/print messages indicating CER >4 % to ≤ 20 % yes

12.5 Unsatisfactory reception

This test is required for all equipment

The equipment shall not store/print messages (ID's) with CER > 33 % yes

12.6 Power-off check

This test is required for equipment not fitted with an integral printer

After 6 hours power-off, the loaded STF in the message store is unchanged yes

After 6 hours power-off, all non-volatile equipment settings are unchanged yes

12.7 Brown-out test

This test is required for all equipment

Required test script:

Reduce supply voltage to 40 % of nominal voltage over 30 s time;

Gradually increase supply voltage to 80 % of nominal voltage over 30 s time;

Results of above test script:

After brown-out, the loaded STF in the message store is unchanged yes

After brown-out, all non-volatile equipment settings are unchanged yes

Satisfactory:

12.8 UTC handling check

*The manufacturer declared that UTC is taken from external source (61162-interface).
During power-down an internal timer takes over.*

This test is required for equipment not fitted with an integral printer

Required test script:

External UTC is applied and STF loaded;

Remove the power for 6 hours; then apply power and after 53 hours check::

After 6 hours power-down, the loaded STF in the message store is unchanged yes

13 Miscellaneous tests

13.1 Spurious emissions

SPURIOUS EMISSIONS POWER LEVEL	
Spurious frequency (MHz)	Power level (dBm)
*	All emissions are more than 10 dB below the limit
--	--
Measurement uncertainty	+ 1.7 / - 1.9 dB
Limit (9 kHz - 2 GHz)	$\leq - 60$ dBm (1 nW) for 9 kHz - 2 GHz

Utilized measuring resolution bandwidth: 100 kHz.

13.2 Special purpose and safety tests

See EN 60945 test report

13.3 Maintenance

See EN 60945 test report

13.4 Equipment manuals – check of manufacturer’s documentation

See EN 60945 test report

13.5 Marking and identification

See EN 60945 test report

Used test equipment module

The following table lists all equipment used.

Measurement Equipment utilized with Draft. IEC 61097-6 Ed. 2.0 (80/403/CDV)				
Nr.	Type	Model	Manufacturer	Serial Nr.
1	Signal generator	2041	Marconi	1119333/015
2	Signal generator	2026B	Marconi	202601/524
3	Navtex Generator	DSC-G1	Furuno	DG-0001
4	PC	CF-28	Panasonic	--
5	Splitter	60NF50	Wiltron	658023
6	Splitter	ZFSC-3-1	Mini-Circuits	15542
7	Spectrum analyzer	R3271	Advantest	15050383
8	Frequency counter	R5362A	Advantest	13720092
9	Oscilloscope	TDS320	Tektronix	B012383
10	Power supply	GP035-10	Takasago	1013895093
11	Digital Multimeter	04681	Futaba-koug	--
12	IEC 61162 testsoftware	--	Furuno	--
13	MF/HF transmitter	FS-1502	Furuno	--