

Test Report

(FCC Rules 47 CFR,
2.1046/2.1047/2.1049/2.1051/2.1053/2.1055/80.215/80.213/80.211)

For

Trade name: Furuno
Model: SSB RADIOTELEPHONE
Type: FS-1575

Report No.: FLI 12-12-063

Date of Issue: 27 April 2012

Furuno Labotech International Co., Ltd.

1-16 Fukazu-cho, Nishinomiya-shi, Hyogo 663-8203, Japan

Tel: +81 798 63 1094 Fax: +81 798 63 1098

URL: <http://www.furuno-labotech.co.jp>

Report Summary

FLI project number:	FLI 04-11-0386		
Test report number of initial issue:	FLI 12-12-063	Date of initial issue	27 April 2012
Test report number of revised/replaced issue:	---	Date of revised/replaced issue	---
Test report revision/ replacement history:	---		
Test standard(s)/ Test specifications:	FCC 47 CFR, Sections: 2.1046 and 80.215 - RF Power Output, 2.1047 and 80.213 - Modulation Characteristics, 2.1049 - Occupied Bandwidth, 2.1051 - Spurious Emissions at Antenna Terminal, 2.1053 - Field Strength of Spurious Radiation, 80.211 - Emission Limitations. 2.1055 and 80.209 - Frequency Stability, (Date of issue: 1 October 2010)		
Customer:	Furuno Electric Co., Ltd. 9-52 Ashihara-Cho, Nishinomiya-City, 662-8580 Japan		
Manufacturer:	Furuno Electric Co., Ltd. 9-52 Ashihara-Cho, Nishinomiya-City, 662-8580 Japan		
Trade name:	FURUNO		
Model:	SSB RADIOTELEPHONE		
Type:	FS-1575		
Product function and intended use:	For Maritime Radiocommunication		
Number of samples tested:	One		
Serial number:	3592-0003		
Power rating:	24 VDC, 20 A		
Product status:	Pre-production model		
Modifications made to samples during testing:	None.		
Date of receipt of samples:	10 March 2012		
Test period:	12 March 2012 to 5 April 2012		
Place of test:	Furuno Labotech International Co., Ltd. - Nishinomiya Lab. 9-52, Ashihara-cho, Nishinomiya-shi, Hyogo, 662-8580 Japan - Nishinomiya-Hama Lab. 2-20, Nishinomiya-Hama, Nishinomiya-shi, Hyogo, 662-0934 Japan Anechoic Chamber used for the test has been registered by FCC. (File number: 90607) Test firm Designation Number: JP2007, Test Firm Registration #: 838049		
Test results/ Compliance:	Passed. The test results of this report relate only to the samples tested.		
Tested by:	Yasuharu Nakamura, Katsumi Imamura, Sadatomo Kuwahara, and Koji Kawai		
Written by:	Akiko Inoue		
Verified by:	Yoshihiro Ishii		
Approved by:	Date: 27 April 2012 Name: Yoshihiro Ishii Title: Senior Manager, Technical Department, Furuno Labotech International Co., Ltd. Signature: 		

Testing Laboratory Status

Furuno Labotech International Co., Ltd. (hereafter called FLI) has been holding the following status after having been assessed according to the provisions of ISO/IEC 17025 and/or the relevant rules:

(1) Telefication Listed Testing Laboratory:

- listed by Telefication B. V., Edisonstraat 12a, 6902 PK Zevenaar, The Netherlands
- Laboratory assignment number: L116
- Date of initial listing: 26 July 1999 (*)
- for testing the following product categories/ test standards:
 - EN 60945, IEC 61162-1/-2, and IEC 62288 for Maritime navigation and radiocommunication equipment and systems

(2) BSH Recognized Testing Laboratory:

- recognized by Bundesamt für Seeschifffahrt und Hydrographie, Bernhad-Nocht-Str. 78, 20359 Hamburg, Federal Republic of Germany
- Recognition certificate number: BSH/4613/06202/1864/11
- Date of initial recognition: 4 April 2003 (*)
- for testing the following product categories/ test standards:
 - IEC/EN 60945, IEC 62388, IEC 61162-1/-2, and IEC 62288 for Marine navigational and radiocommunication equipment and systems

(3) TÜV Appointed EMC Test Laboratory:

- appointed by TÜV Rheinland Japan Ltd., 19-5 Shin Yokohama 3-chome, Kohoku-ku, Yokohama 222-0033 Japan
- Laboratory assignment number: UA 50046428
- Date of initial appointment: 21 December 1998 (*)
- for carrying out the tests of:
 - EN 55011, CISPR 11, EN 55022, CISPR 22, EN 55024, CISPR 24, EN 55025, CISPR 25, EN/IEC 61000-3-2/-3, EN/IEC 61000-4-2/-3/-4/-5/-6/-8/-11, EN/IEC 61000-6-1/-2/-3/-4, EN/IEC 60945, EN/IEC 61326-1, EN/IEC 61326-2-6, EN/IEC 60601-1-2, JIS T 0601-1-2, JIS C 1806-1, ISO 11452-1/-2/-4.

(4) RMRS Recognized Testing Laboratory:

- recognized by Russian Maritime Register of Shipping, 8, Dvortsovaya Nab., St. Petersburg, 191186 Russia
- Laboratory recognition number: 11.02594.011
- Date of initial recognition: 27 January 2009 (*)
- for carrying out testing in the field of:
 - 21001301 Electrical measurements and tests, 21001302 EMC tests, 21001500 Mechanical measurements and tests, 21002000 Equipment protection degree tests, and 21002100 Climatic tests for Ship's radio and navigational equipment and IEC 60945: 2002

Note: (*) – The current certificates may be found in the FLI web site (<http://www.furuno-labotech.co.jp>)

TABLE OF CONTENTS

Report Summary	2
Testing Laboratory Status	3
1 Principal Information.....	5
1.1 Specifications	5
1.2 Observation and comments	5
2 Test Results Summary	5
3 Test Results	6
3.1 RF Power Output (FCC Rules Part 80.215 & 2.1046).....	6
3.2 Modulation Characteristics (FCC Rule Part 2.1047)	7
3.2.1 Audio Frequency Response (FCC Rules Part 2.1047(a) & 80.213)	7
3.2.2 Power Limiting vs Audio Input Voltage (FCC Rule Part 2.1047(c) & 80.213).....	9
3.3 Occupied Bandwidth (FCC Rule Part 2.1049).....	10
3.4 Emission Limitations (FCC Rule Part 80.211).....	26
3.5 Spurious Emissions at Antenna Terminal (FCC Rule Part 2.1051 & 80.211)	42
3.6 Field Strength of Spurious Radiation (FCC Rule Part 2.1053).....	60
3.7 Frequency Stability (FCC Rule Part 2.1055 & 80.209).....	73
4 List of Measuring/Test Instruments	78

1 Principal Information

1.1 Specifications

(a) Manufacturer:	Furuno Electric Co., Ltd., Japan
(b) Model:	FS-1575 (Serial No.: 3592-0003)
(c) Frequency Range:	1605 kHz to 27.5 MHz (transmit) 0.1 MHz to 29.99999 MHz (receive)
(d) Class of Emission:	J3E: Telephone F1B (J2B): DSC and NBDP
(e) Rated Output Power:	J3E: 150 W _{pep} F1B (J2B): 150 W
(f) Power Supply:	24 VDC 5 A (receive) 20 A (max) (transmit)
(g) Dimensions and Weight:	Transceiver Unit FS-1575T. 340 mm (W) x 198 mm (H) x 390 mm (D) 15 kg Control Unit FS-2575C. 258 mm (W) x 108 mm (H) x 101 mm (D) 2.2 kg.

1.2 Observation and comments

None.

2 Test Results Summary

47 CFR Section	Item	Result	Test Engineer
80.215 & 2.1046	RF POWER OUTPUT	Passed.	K. Kawai
2.1047	Modulation Characteristics	---	---
2.1047(a) & 80.213	Audio Frequency Response	Passed.	K. Kawai
2.1047(c) & 80.213	Power Limiting vs Audio Input Voltage	Passed.	K. Kawai
2.1049	Occupied Bandwidth	Passed.	K. Kawai and S. Kuwahara
80.211	Emission Limitations	Passed.	K. Kawai
2.1051	Spurious Emissions at Antenna Terminal	Passed.	K. Kawai
2.1053	Field Strength of Spurious Radiation	Passed.	K. Imamura
2.1055 & 80.209	Frequency Stability	Passed.	Y. Nakamura

3 Test Results

3.1 RF Power Output (FCC Rules Part 80.215 & 2.1046)

(1) Method of Measurement

The FS-1575 was connected with measuring equipment as shown in Fig. 3.1.1

Supply voltage was set to 24.0 VDC. AC/DC Current Probe was connected in series with collector of each final stage transistor. Test was made under normal environmental condition.

Multi Function Synthesizer generating each 400 Hz and 1800 Hz audio signal at an equal level was adjusted to produce transmitter RF output power 150 Wpep. Collector current was then measured.

Measurement was made on every test frequency on class of emission J3E.

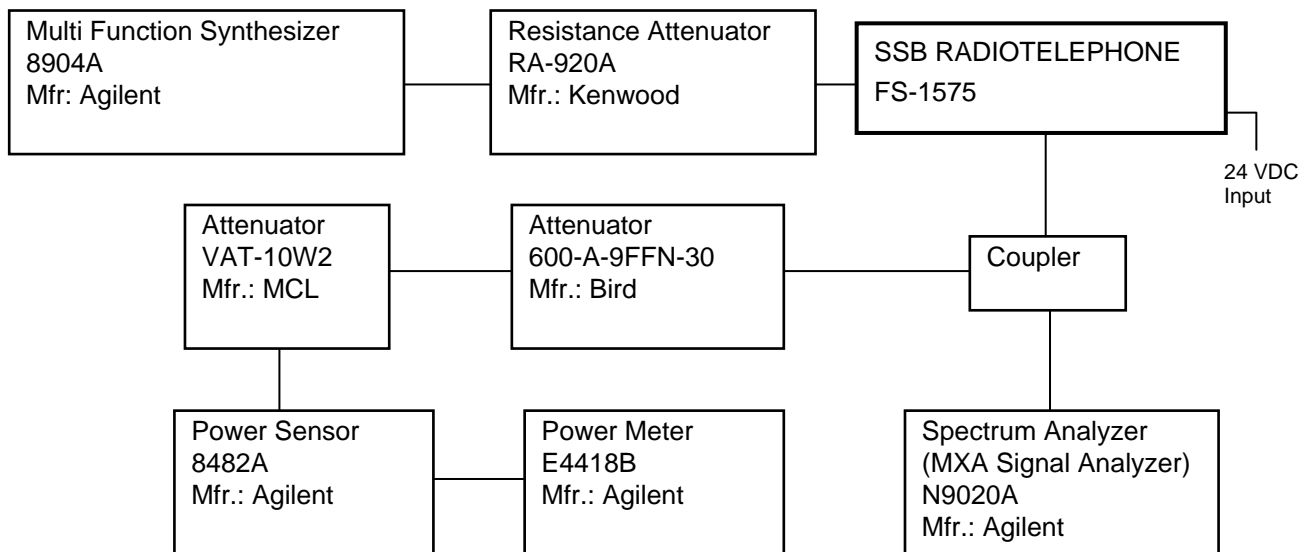

Fig. 3.1.1

(2) Test Result

Results are shown in Table 3.1.1

Table 3.1.1

Frequency (kHz)	Class of Emission	Power Supply		Collector		PEP (W)
		Voltage (VDC)	Current (A)	Voltage (VDC)	Current (A)	
1605	J3E	24.0	8.7	23.5	7.6	139
2182	J3E	24.0	10.0	23.4	8.9	140
3300	J3E	24.0	8.6	23.5	7.5	144
4125	J3E	24.0	8.9	23.5	7.6	142
6215	J3E	24.0	8.0	23.6	6.8	146
8291	J3E	24.0	7.9	23.6	6.7	146
12290	J3E	24.0	9.8	23.4	8.6	144
16420	J3E	24.0	9.0	23.5	7.7	136
18780	J3E	24.0	10.3	23.4	9.1	138
22000	J3E	24.0	8.6	23.5	7.5	140
25070	J3E	24.0	9.6	23.4	8.4	138

Environmental conditions observed: On 21 March 2012, 23°C to 23°C, 28% to 28%RH, 24.0 VDC to 24.0 VDC.

3.2 Modulation Characteristics (FCC Rule Part 2.1047)

3.2.1 Audio Frequency Response (FCC Rules Part 2.1047(a) & 80.213)

(1) Method of Measurement

The FS-1575 was connected with measuring equipment as shown in Fig. 3.2.1.

A single audio tone was applied to the transmitter and varied over the range 150 Hz to 2900 Hz. Output power was measured for variation of audio frequency with the output level 30 W referred to as 0 dB.

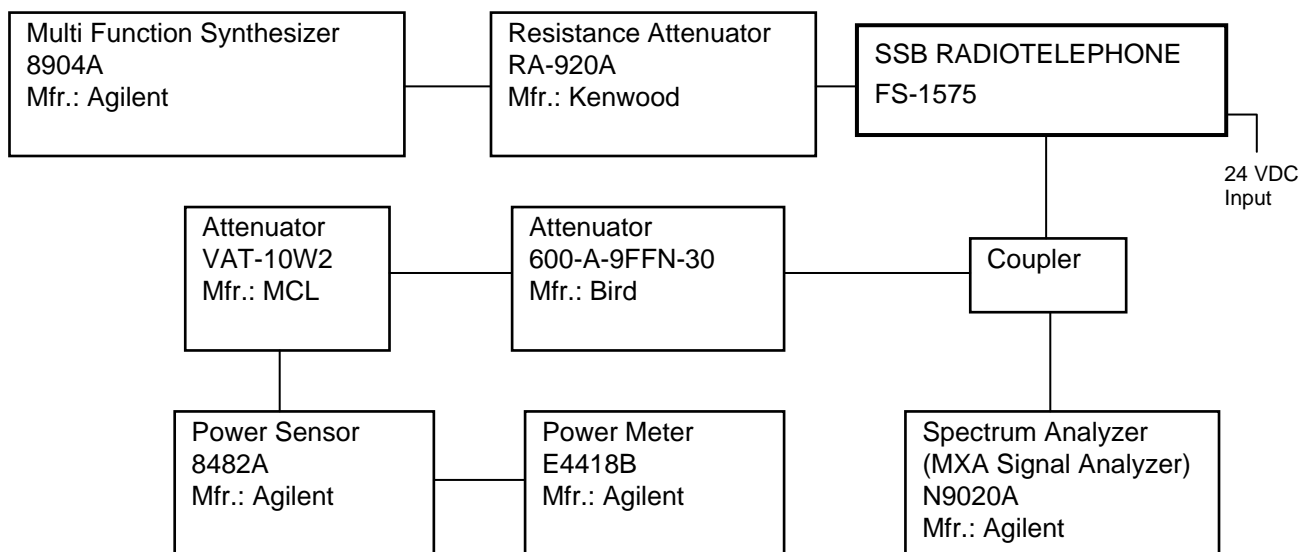

Fig. 3.2.1

(2) Test Result

1. Output level for respective audio frequency is plotted in Fig. 3.2.2.
2. Carrier level was shown in Table 3.2.1A.

Table 3.2.1A

		below pep	Standard
J3E	Suppressed Carrier mode	65 dB	at least 40 dB

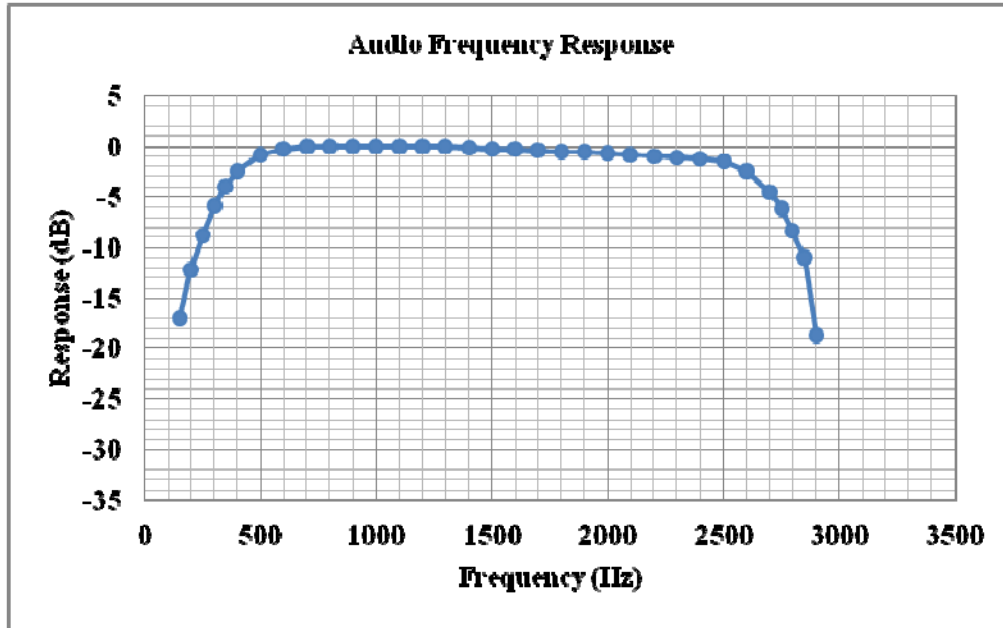

Fig. 3.2.2 Audio Frequency Response

Environmental conditions observed: On 21 March 2012, 23°C to 23°C, 28% to 28%RH
24.0 VDC to 24.0 VDC

3.2.2 Power Limiting vs Audio Input Voltage (FCC Rule Part 2.1047(c) & 80.213)

(1) Method of Measurement

The FS-1575 was connected with measuring equipment as shown in Fig. 3.2.2.

Two audio tones of 400 Hz and 1800 Hz were applied to the transmitter in equal level. The input level was varied and PEP was measured.

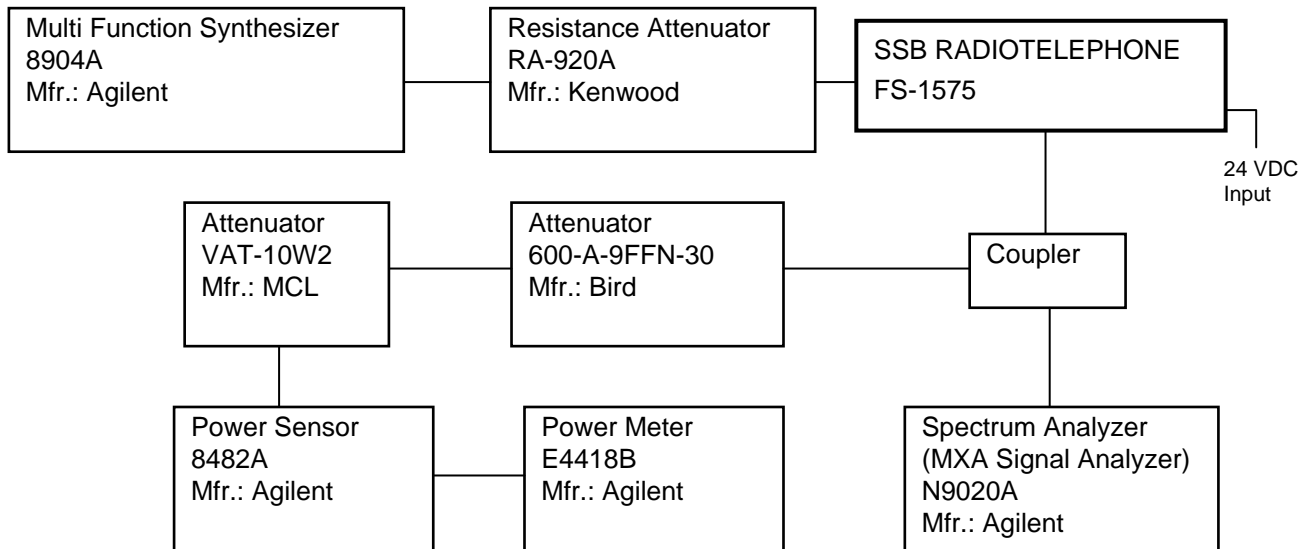

Fig. 3.2.2

(2) Test Result

Measurement was made on frequency 4125 kHz. The results are shown in Fig. 3.2.3.

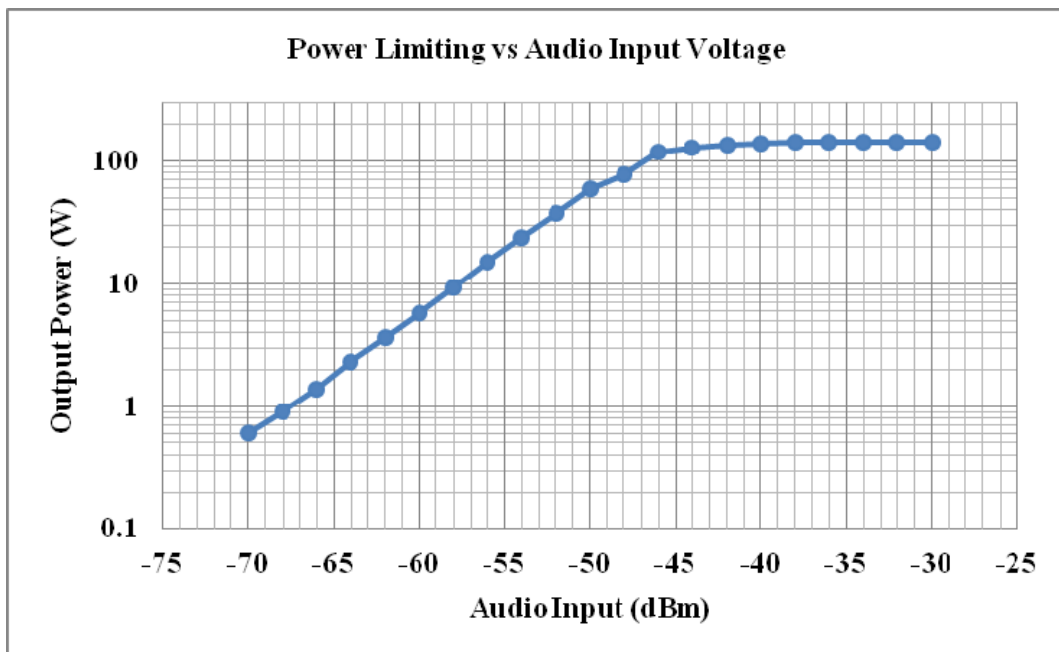

Fig. 3.2.3 Power Limiting vs Audio Input Level

Environmental conditions observed: On 21 March 2012, 23°C to 23°C, 26% to 26%RH
24.0 VDC to 24.0 VDC

3.3 Occupied Bandwidth (FCC Rule Part 2.1049)

(1) Method of Measurement

The FS-1575 was connected with measuring equipment as shown in Fig. 3.3.1.

Two audio tones of 400 Hz and 1800 Hz were applied, in equal level, to the transmitter. The level was adjusted to 10 dB above the level producing PEP output of 150 W for test frequencies 4 MHz or below.

The output was monitored with Spectrum Analyzer with settings of span 50 kHz, IF bandwidth (resolution bandwidth) 300 Hz and video bandwidth 300 Hz.

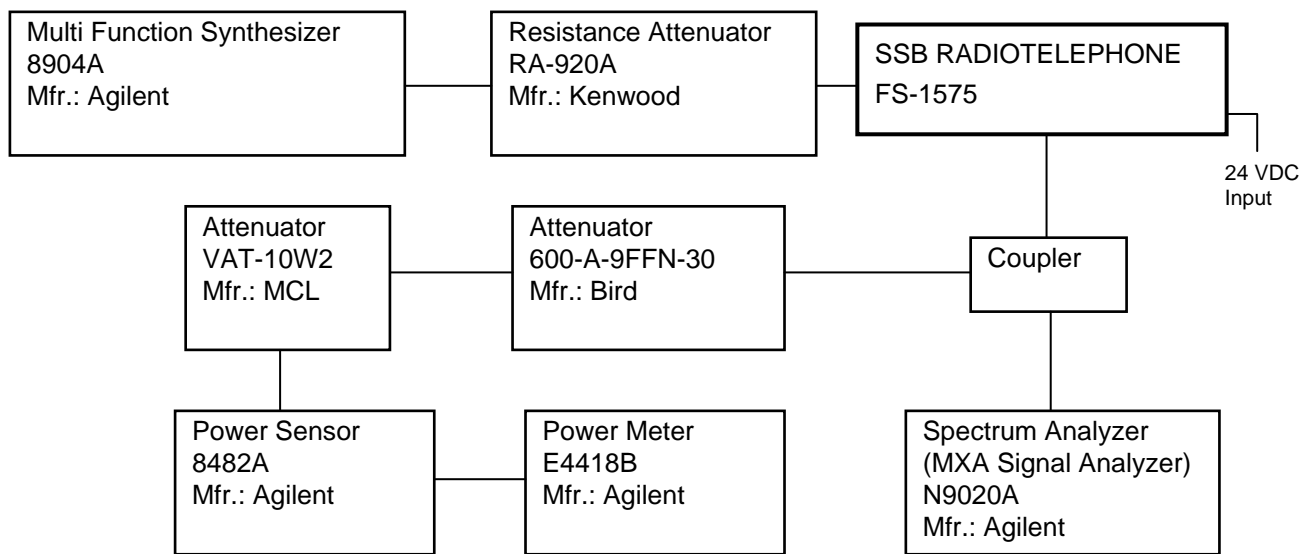

Fig. 3.3.1

(2) Test Result

Results are shown in Fig. 3.3.2 through 3.3.30.

Occupied bandwidth is a bandwidth in which 99 % of the mean power radiated falls.

Environmental conditions observed: On 22 March 2012, 20°C to 23°C, 28% to 29%RH
24.0 VDC to 24.0 VDC

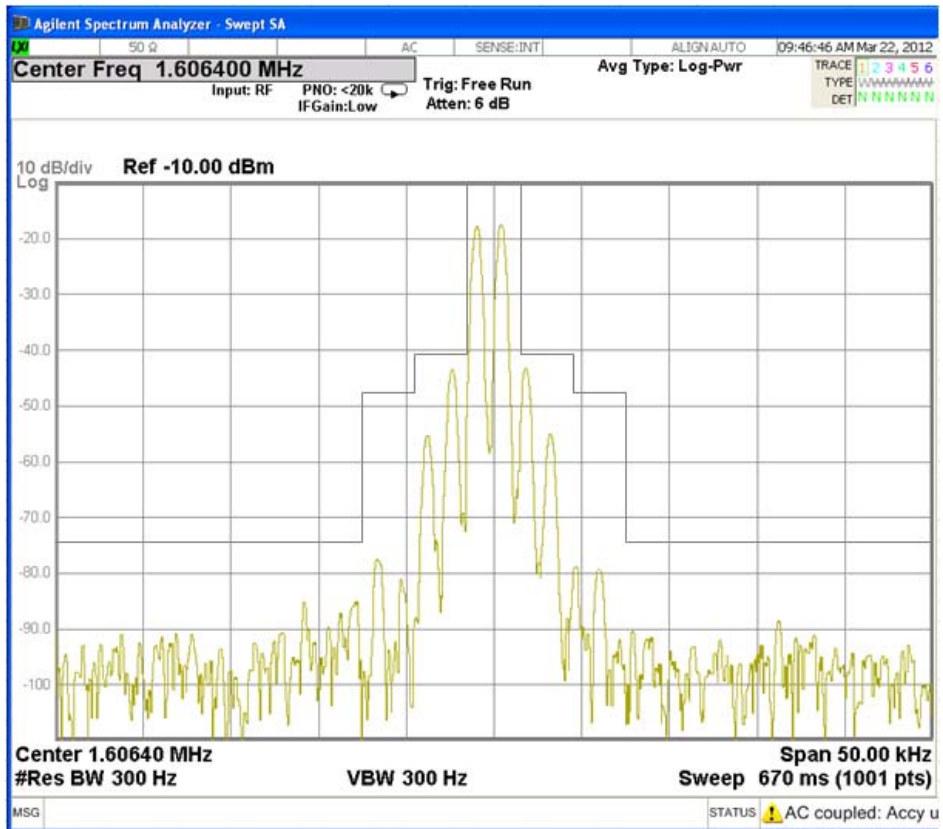

Fig. 3.3.2 SSB: Tx Frequency 1605 kHz

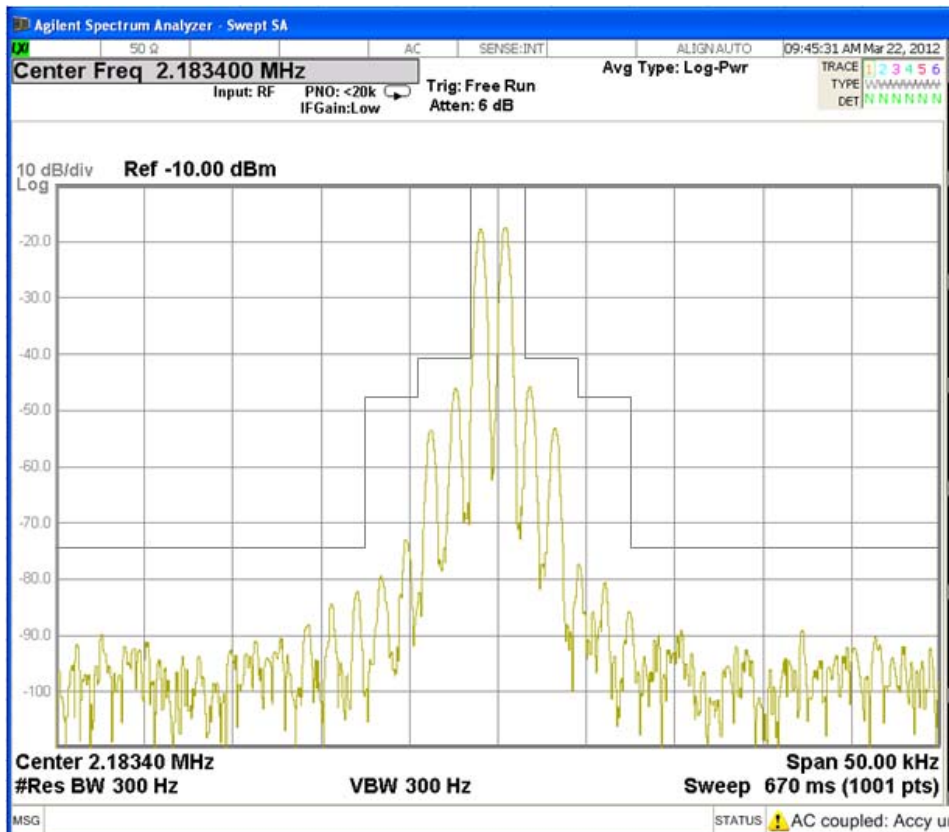

Fig. 3.3.3 SSB: Tx Frequency 2182 kHz

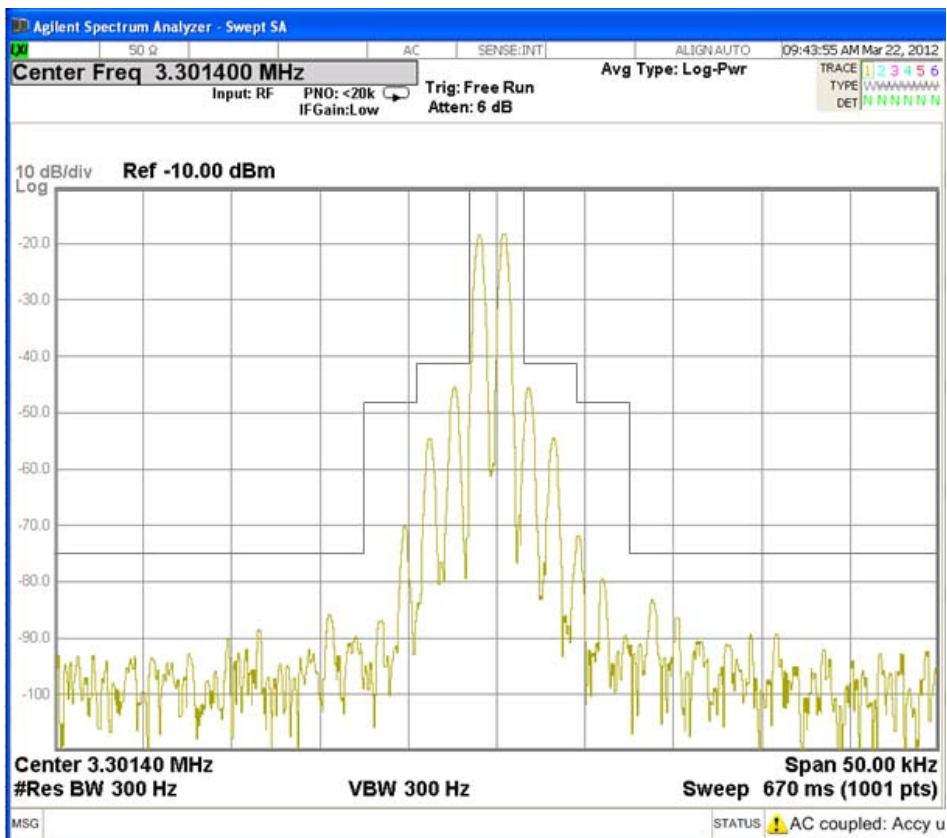

Fig. 3.3.4 SSB: Tx Frequency 3300 kHz

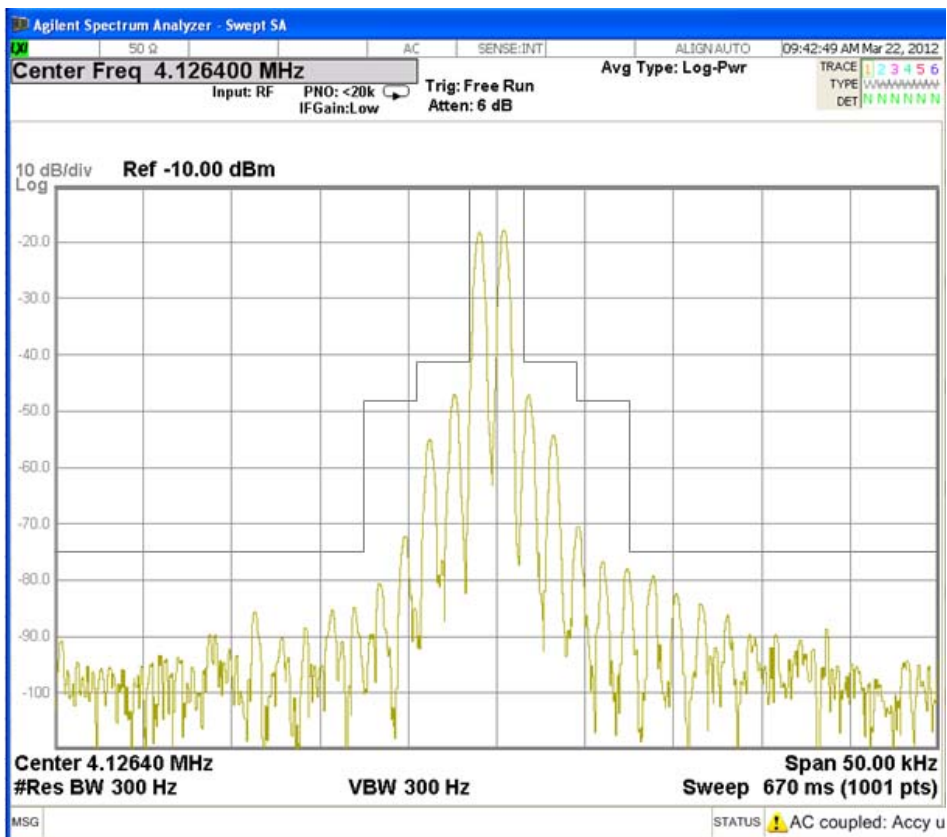

Fig. 3.3.5 SSB: Tx Frequency 4125 kHz

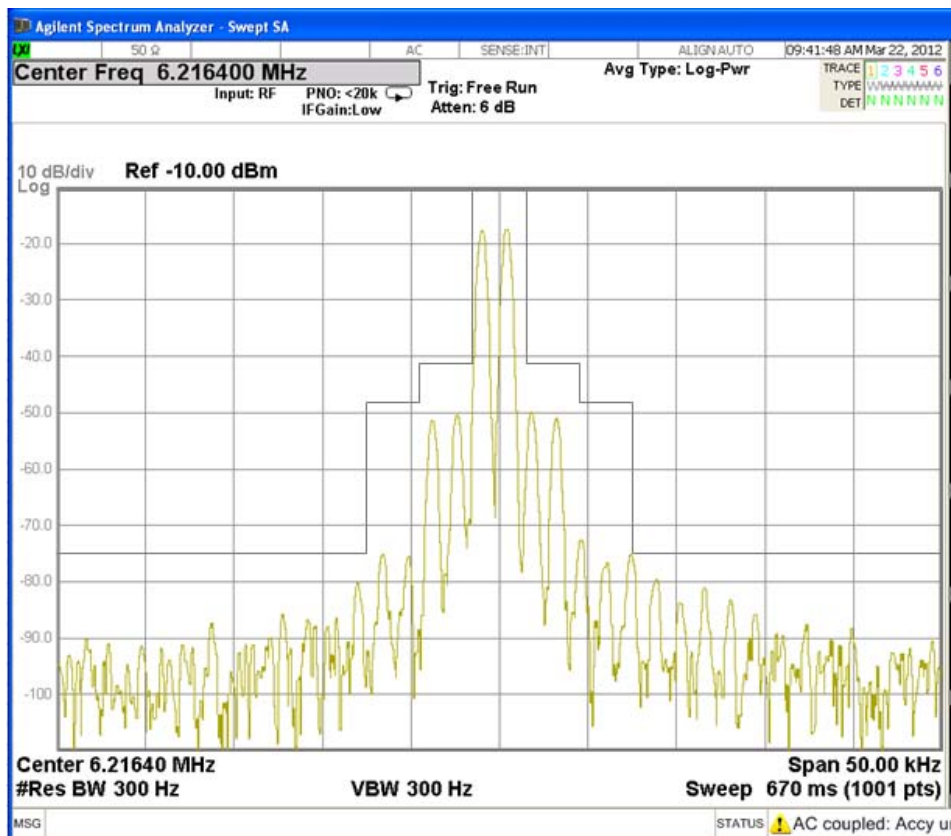

Fig. 3.3.6 SSB: Tx Frequency 6215 kHz

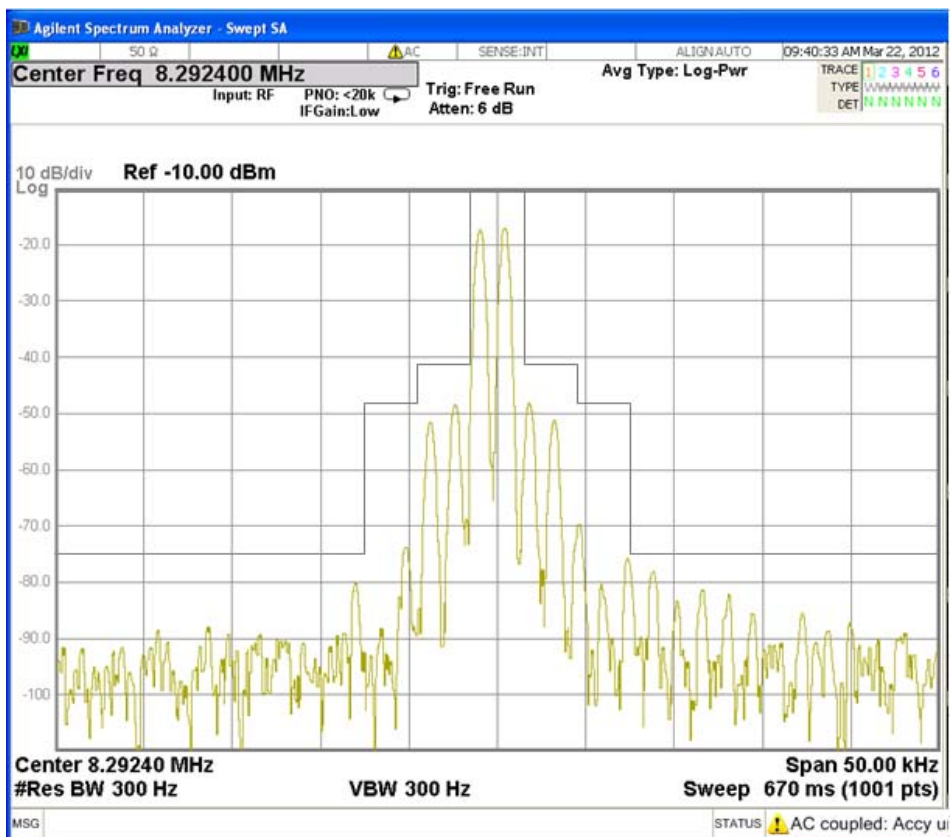

Fig. 3.3.7 SSB: Tx Frequency 8291 kHz

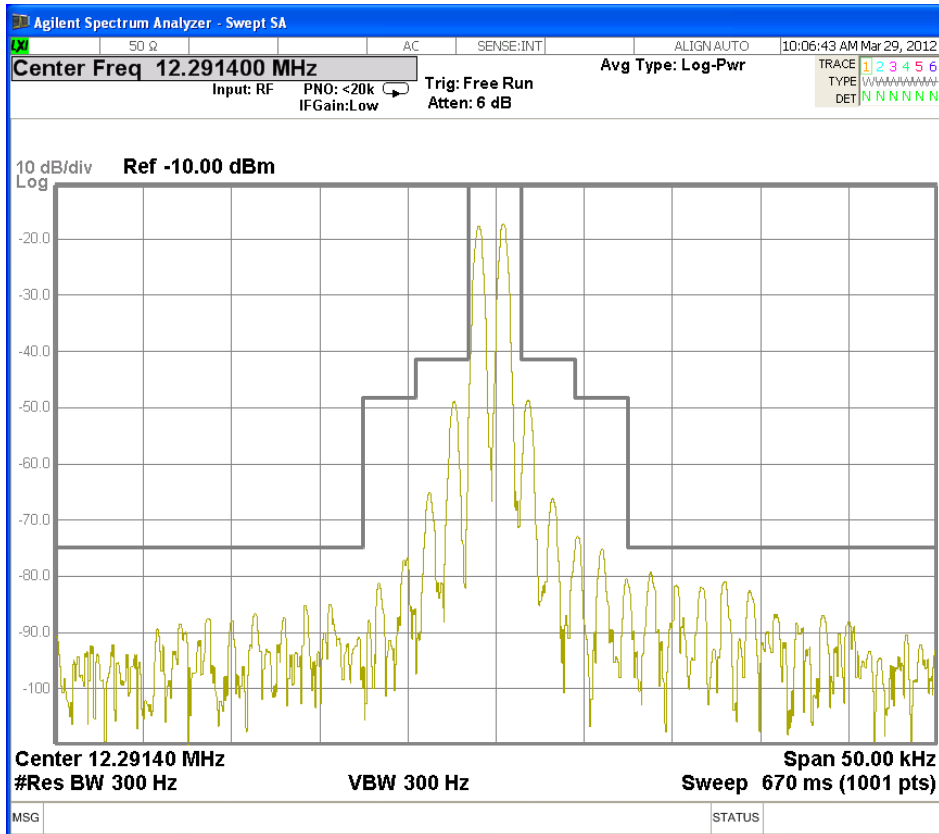

Fig. 3.3.8 SSB: Tx Frequency 12290 kHz

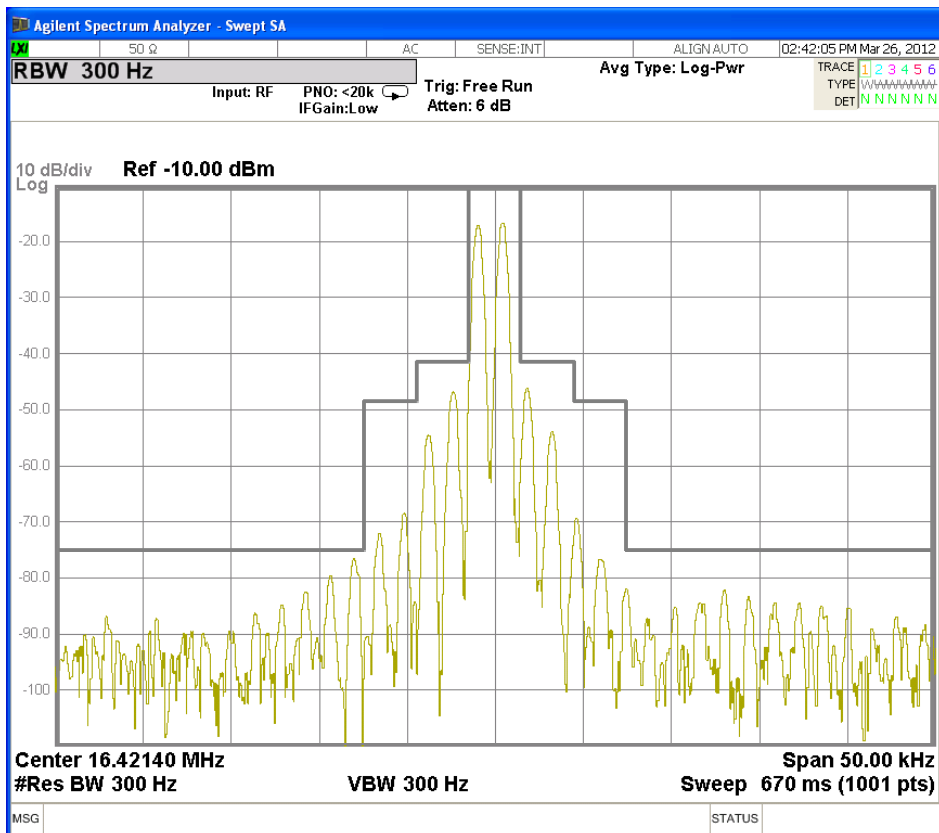

Fig. 3.3.9 SSB: Tx Frequency 16420 kHz

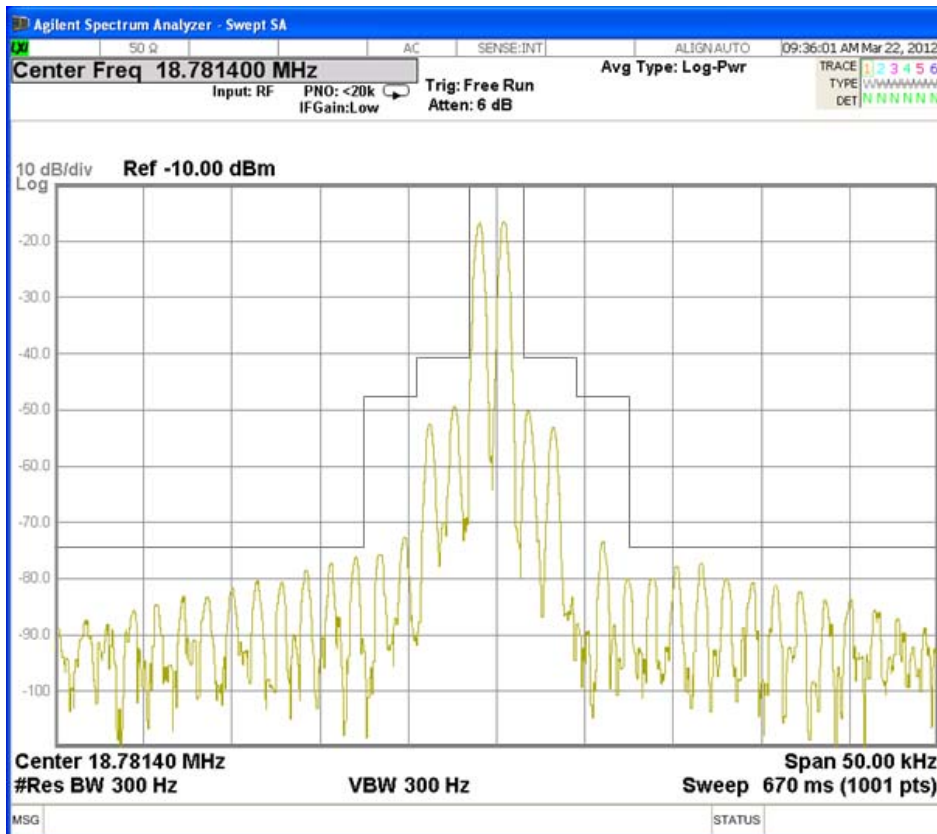

Fig. 3.3.10 SSB: Tx Frequency 18780 kHz

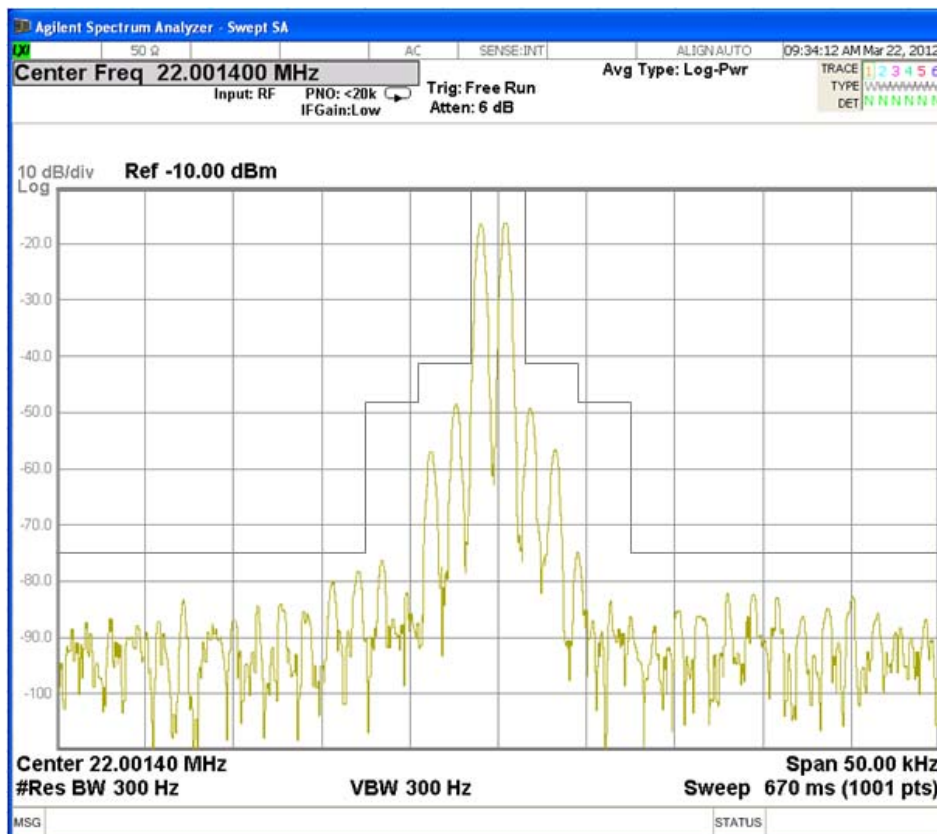

Fig. 3.3.11 SSB: Tx Frequency 22000 kHz

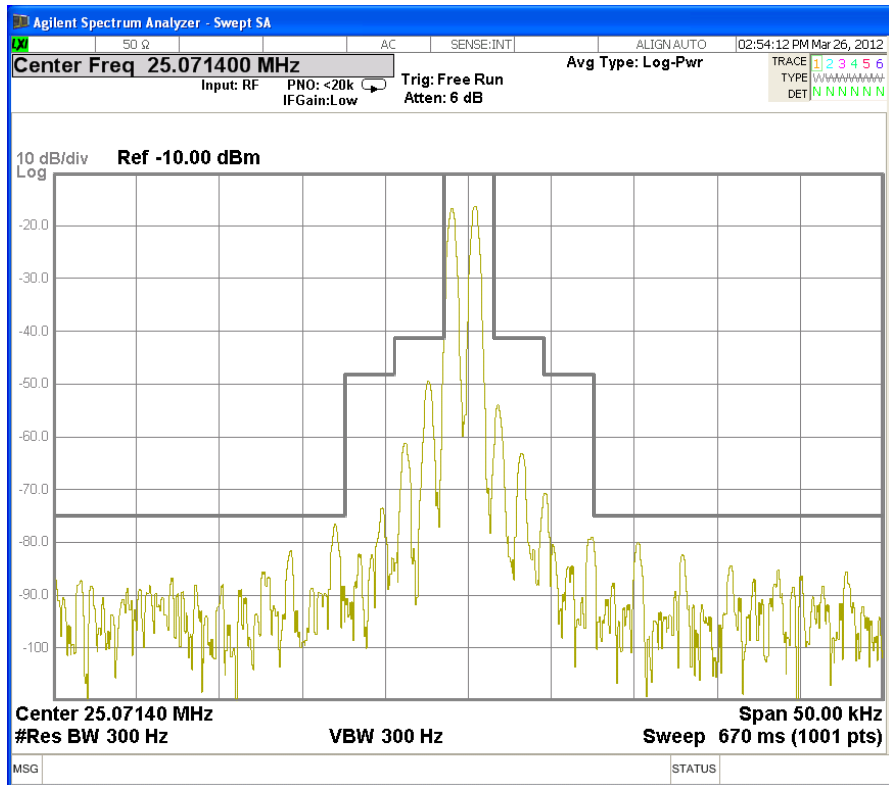

Fig. 3.3.12 SSB: Tx Frequency 25070 kHz

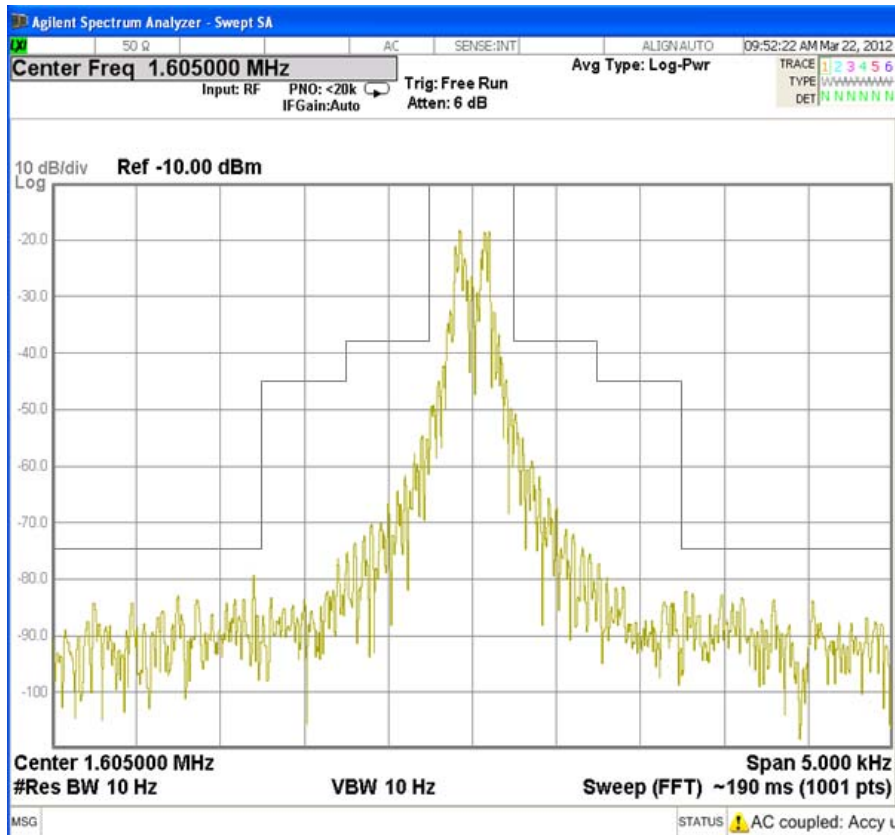

Fig. 3.3.13 NBDP(ARQ): Tx Frequency 1605 kHz

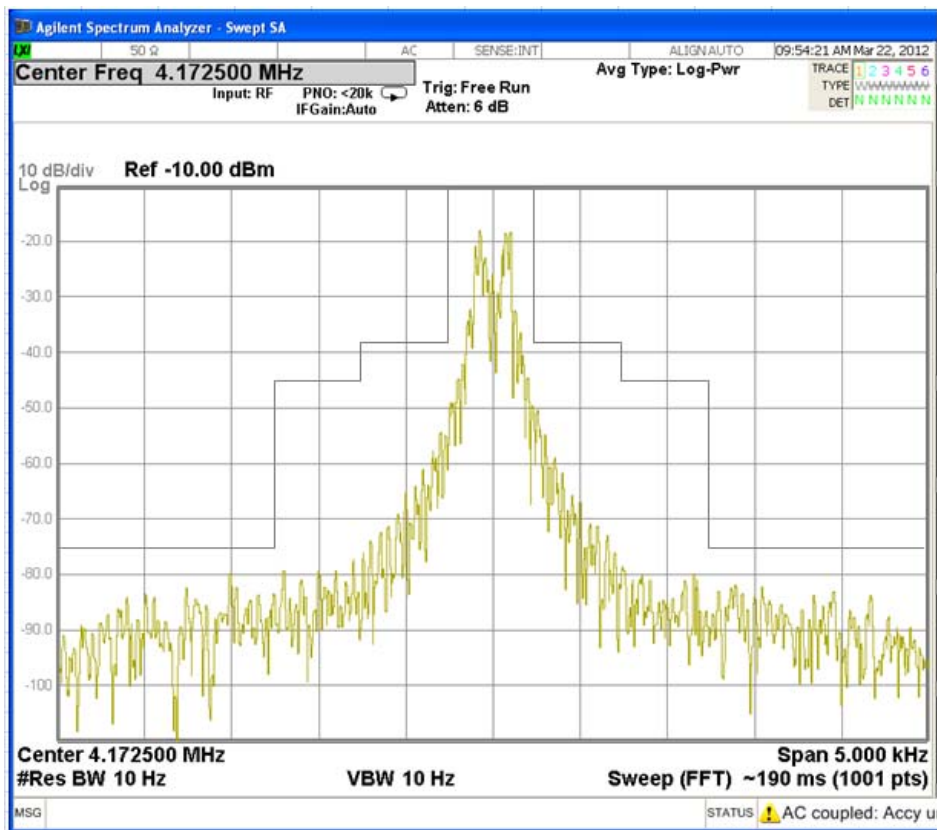

Fig. 3.3.14 NBDP(ARQ): Tx Frequency 4172.5 kHz

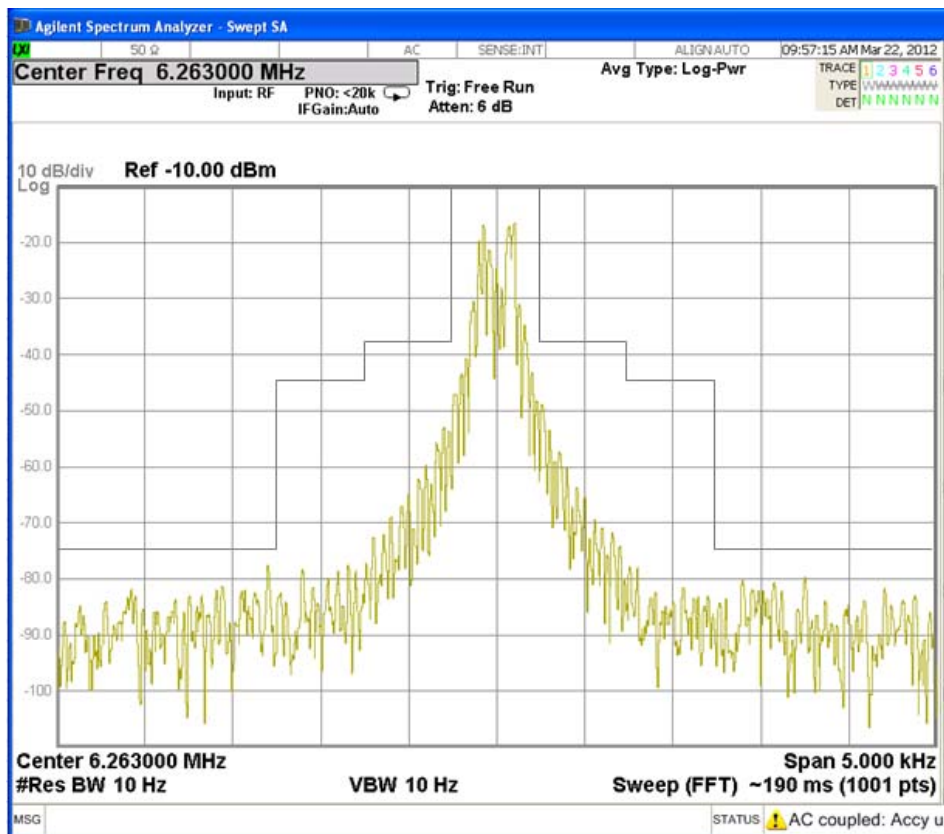

Fig. 3.3.15 NBDP(ARQ): Tx Frequency 6263 kHz

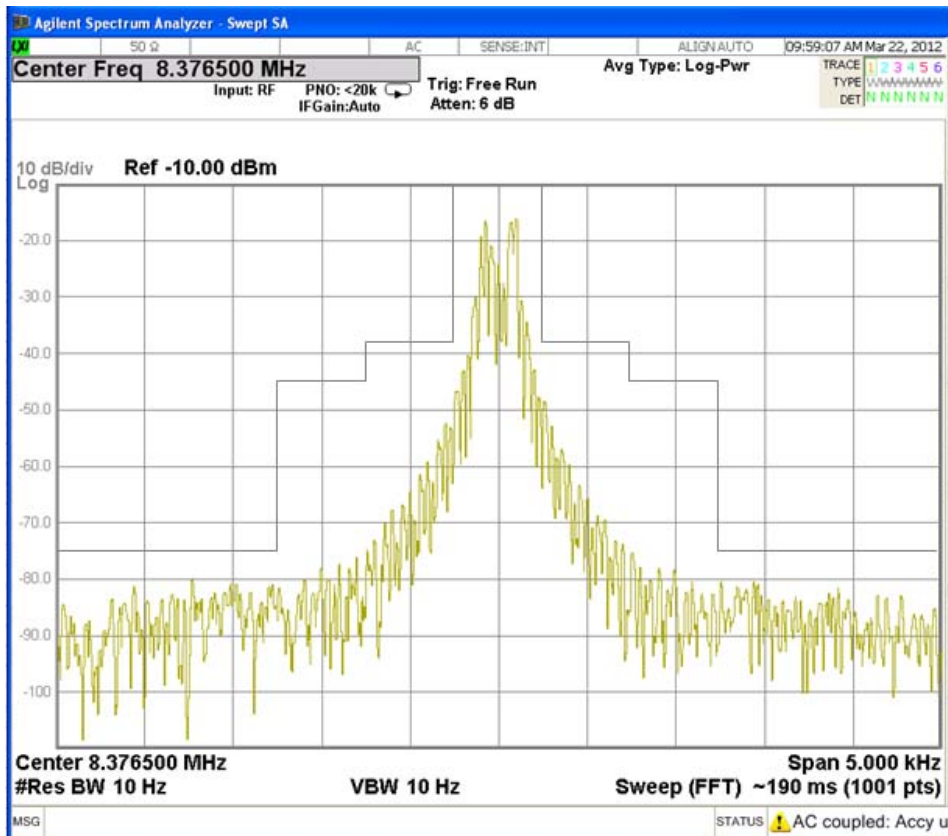

Fig. 3.3.16 NBDP(ARQ): Tx Frequency 8376.5 kHz

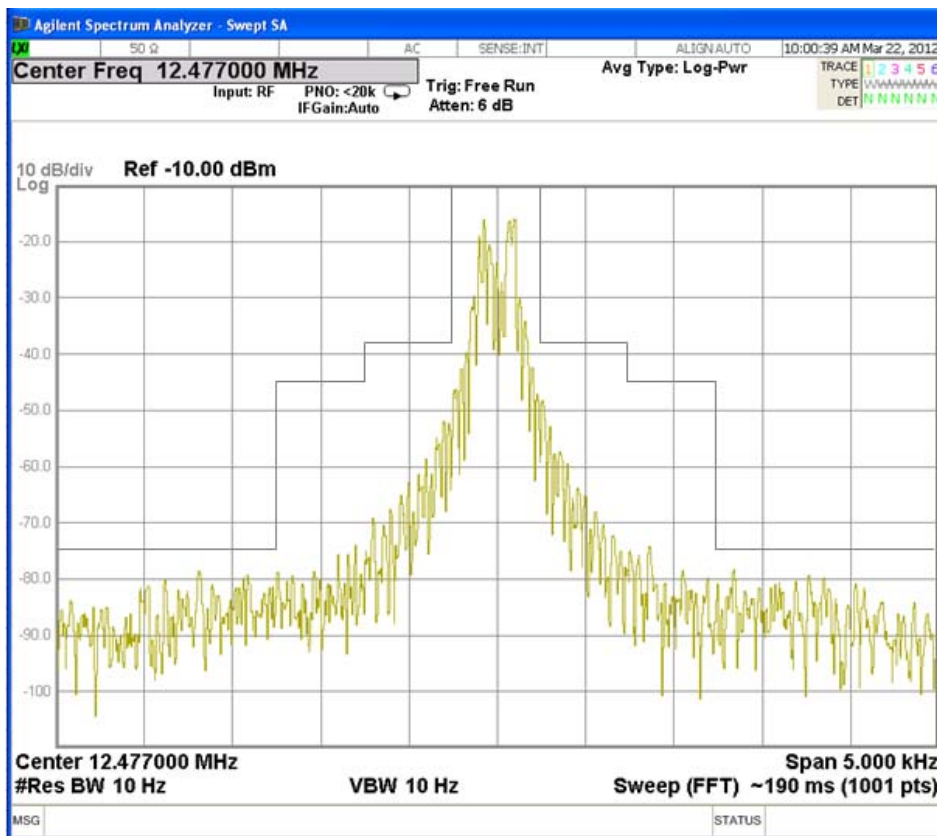

Fig. 3.3.17 NBDP(ARQ): Tx Frequency 12477 kHz

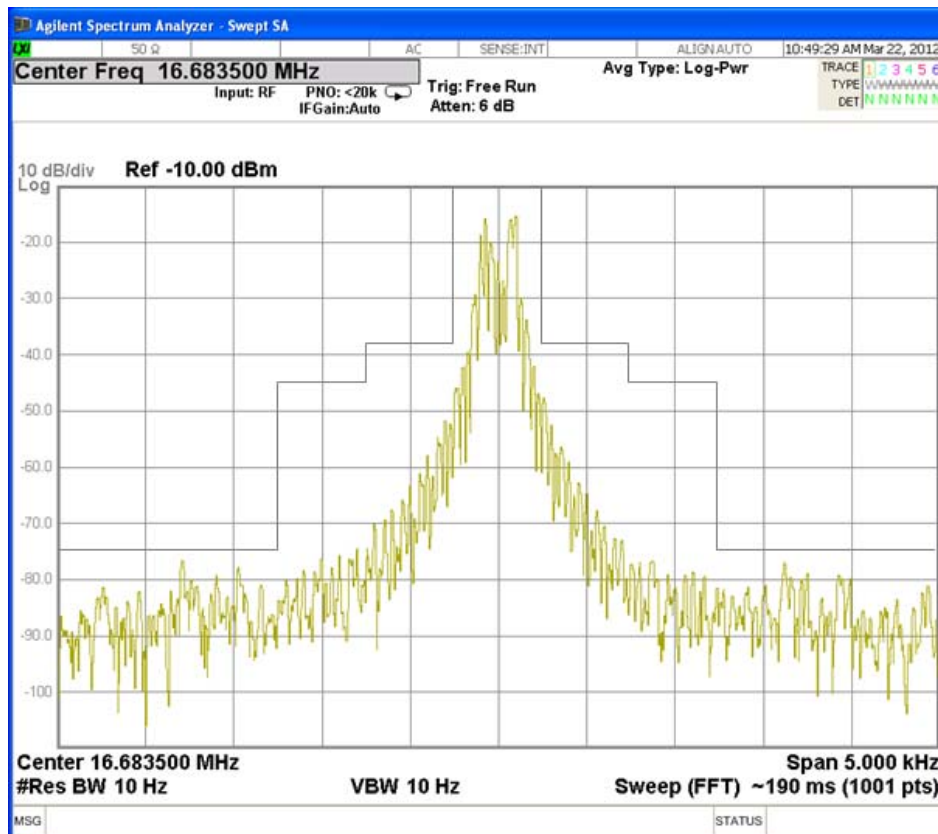

Fig. 3.3.18 NBDP(ARQ): Tx Frequency 16683.5 kHz

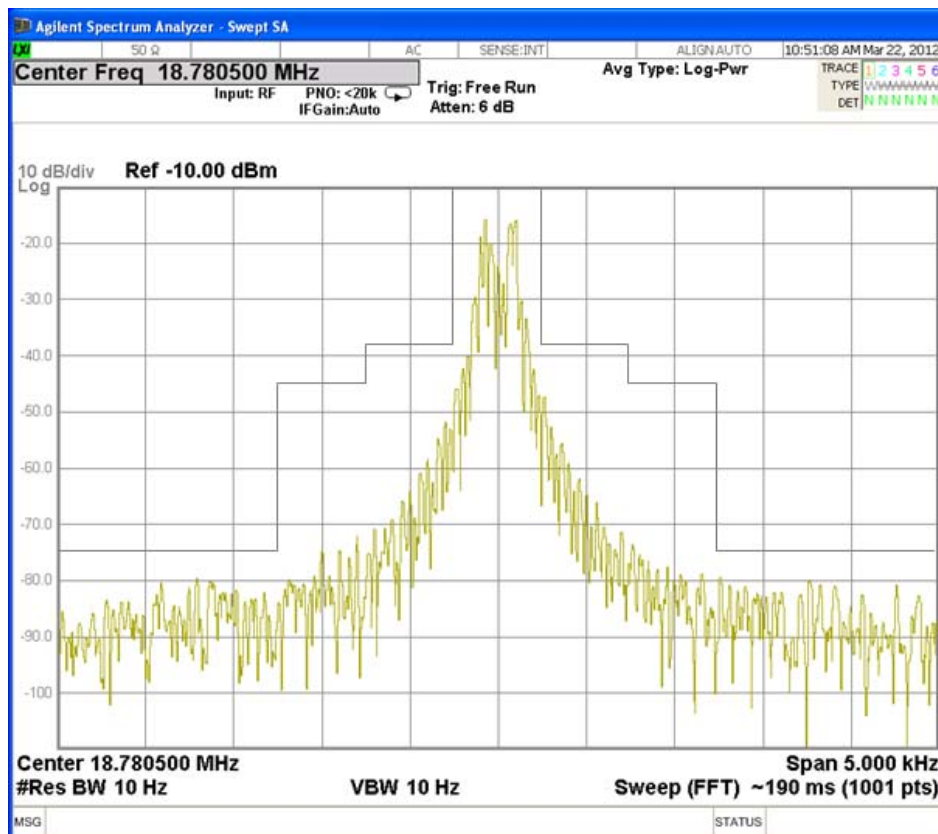

Fig. 3.3.19 NBDP(ARQ): Tx Frequency 18780.5 kHz

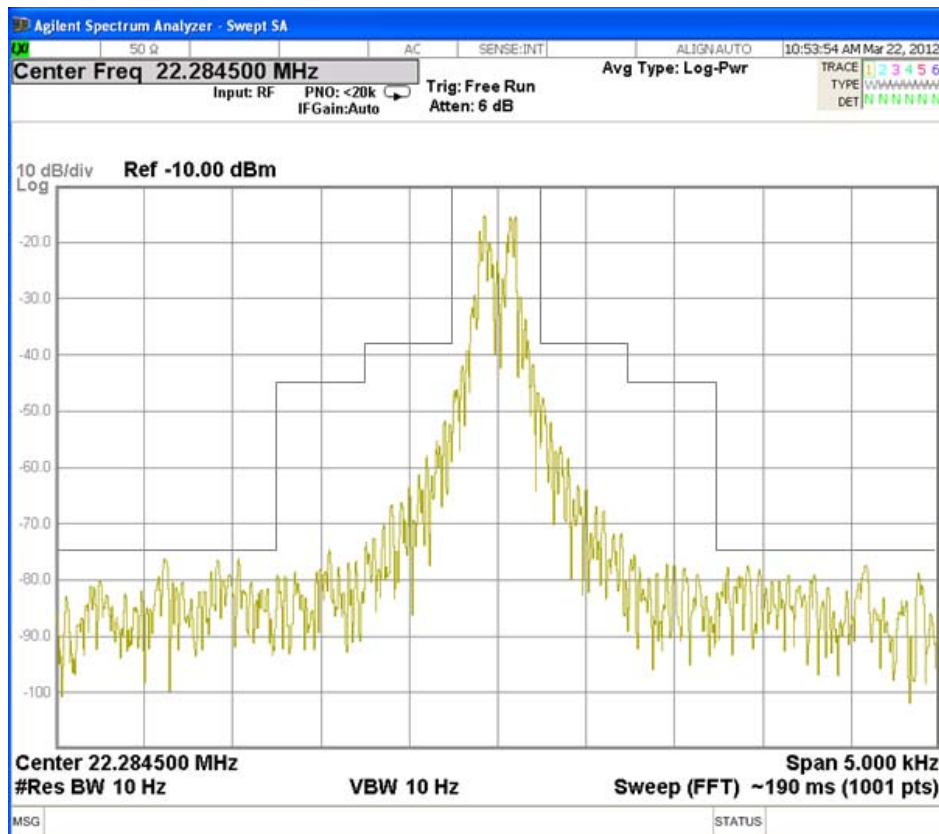

Fig. 3.3.20 NBDP(ARQ): Tx Frequency 22284.5 kHz

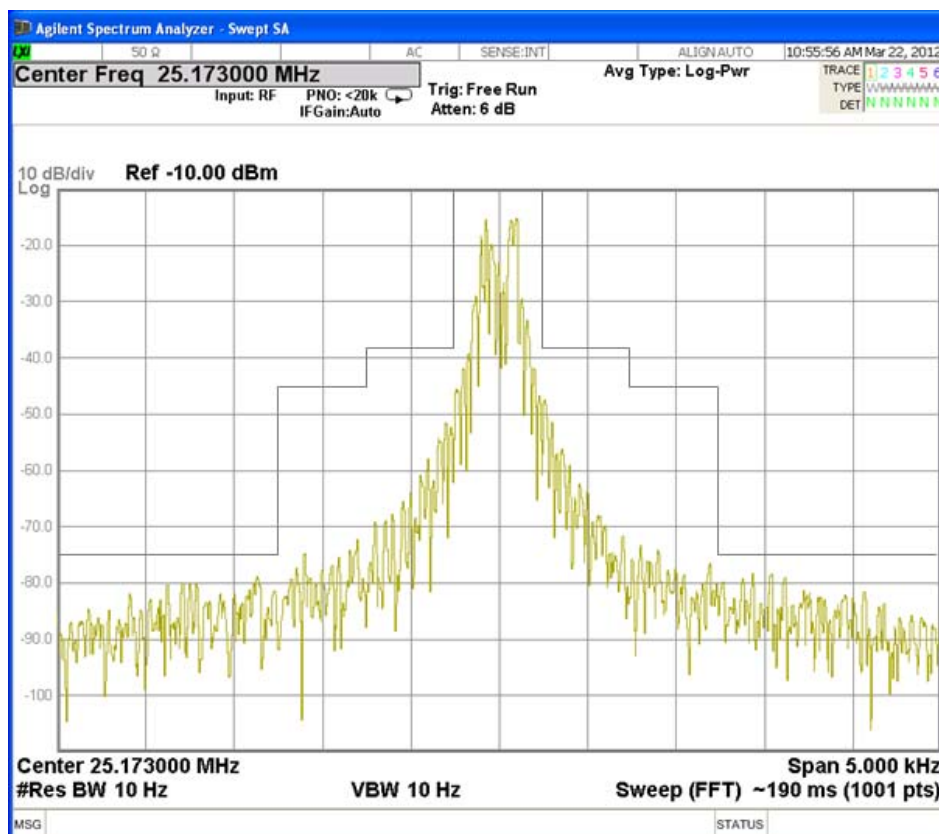

Fig. 3.3.21 NBDP(ARQ): Tx Frequency 25173 kHz

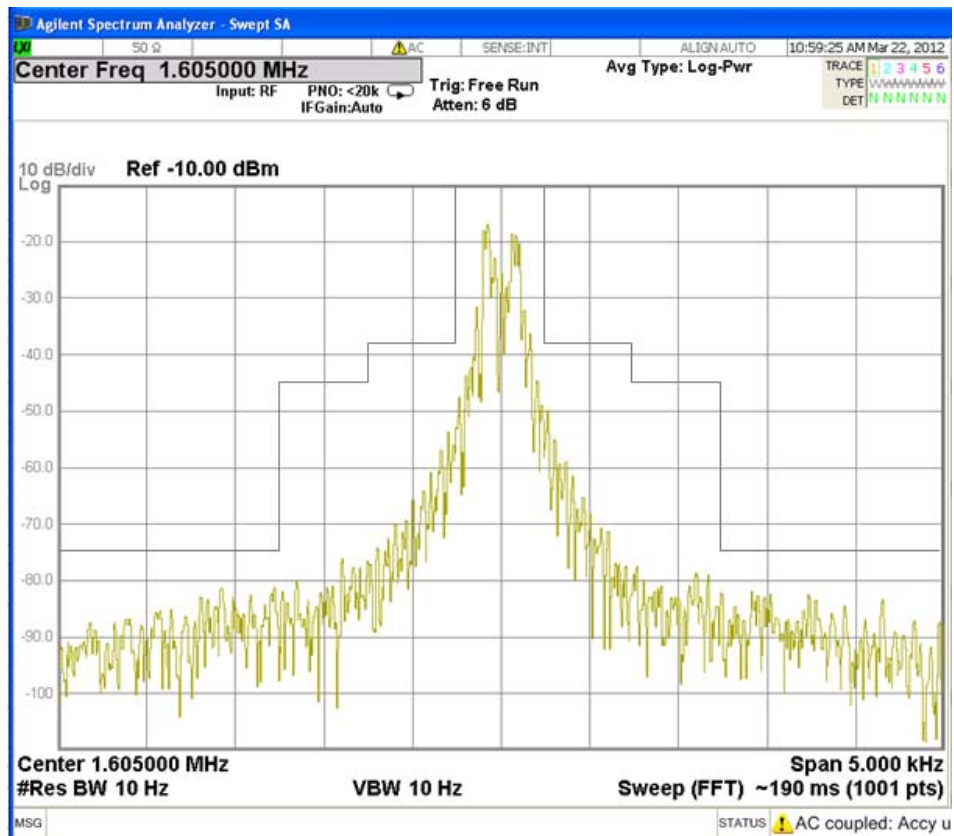

Fig. 3.3.22 NBDP(FEC): Tx Frequency 1605 kHz

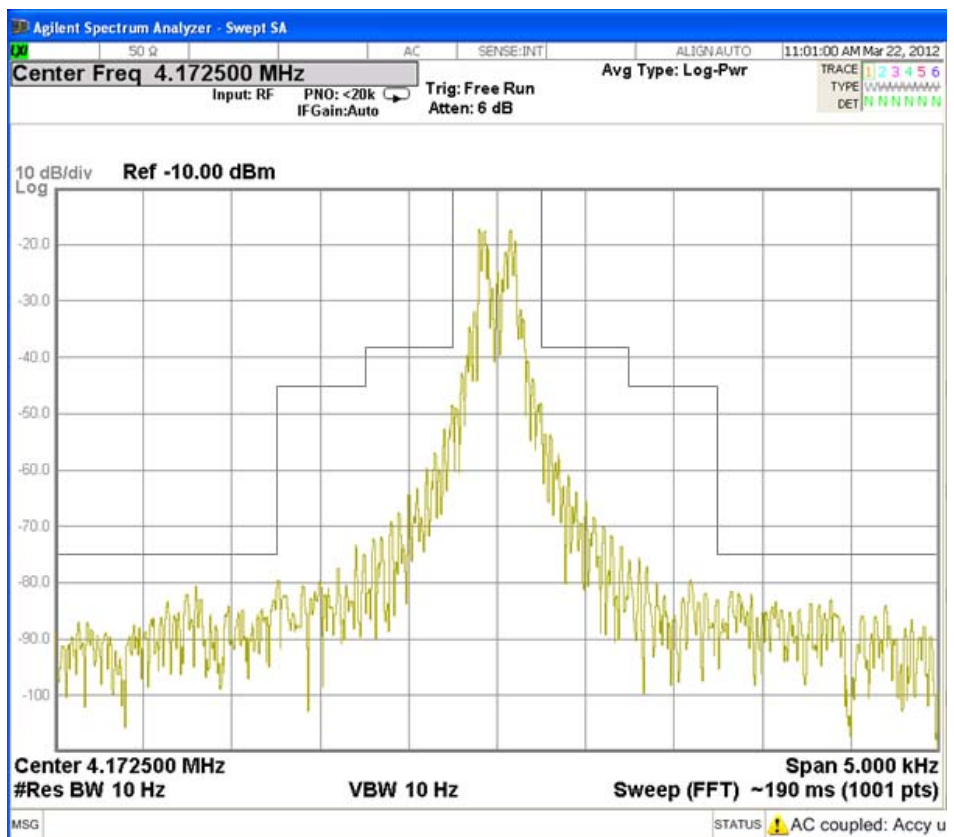

Fig. 3.3.23 NBDP(FEC): Tx Frequency 4172.5 kHz

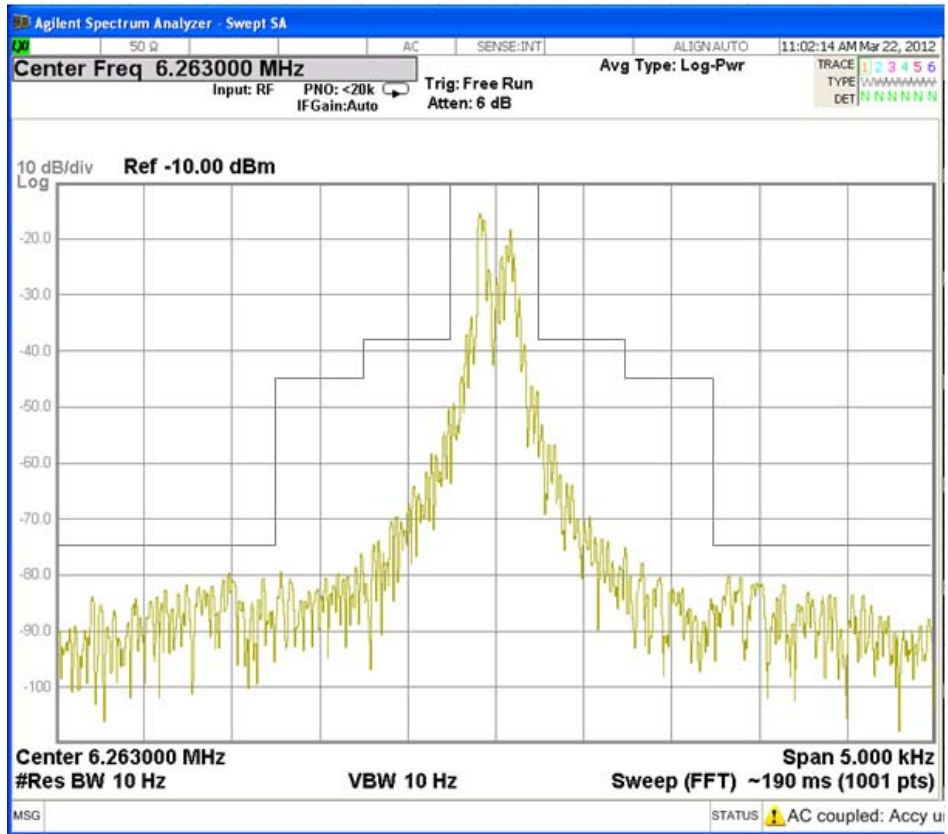

Fig. 3.3.24 NBDP(FEC): Tx Frequency 6263 kHz

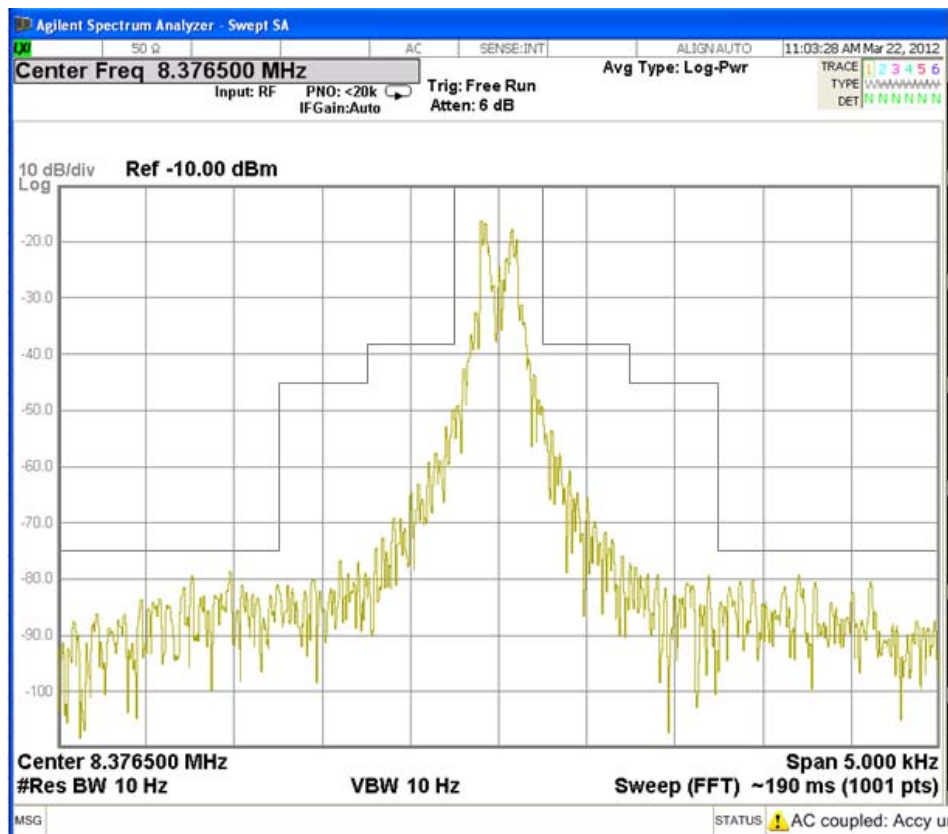

Fig. 3.3.25 NBDP(FEC): Tx Frequency 8376.5 kHz

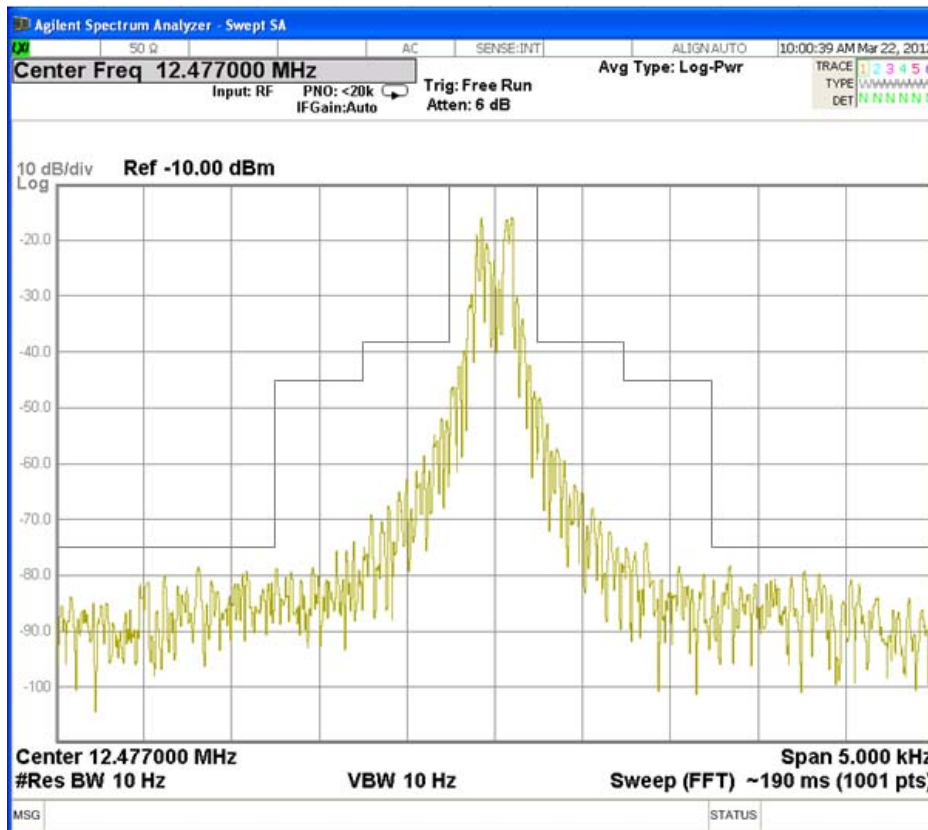

Fig. 3.3.26 NBDP(FEC): Tx Frequency 12477 kHz

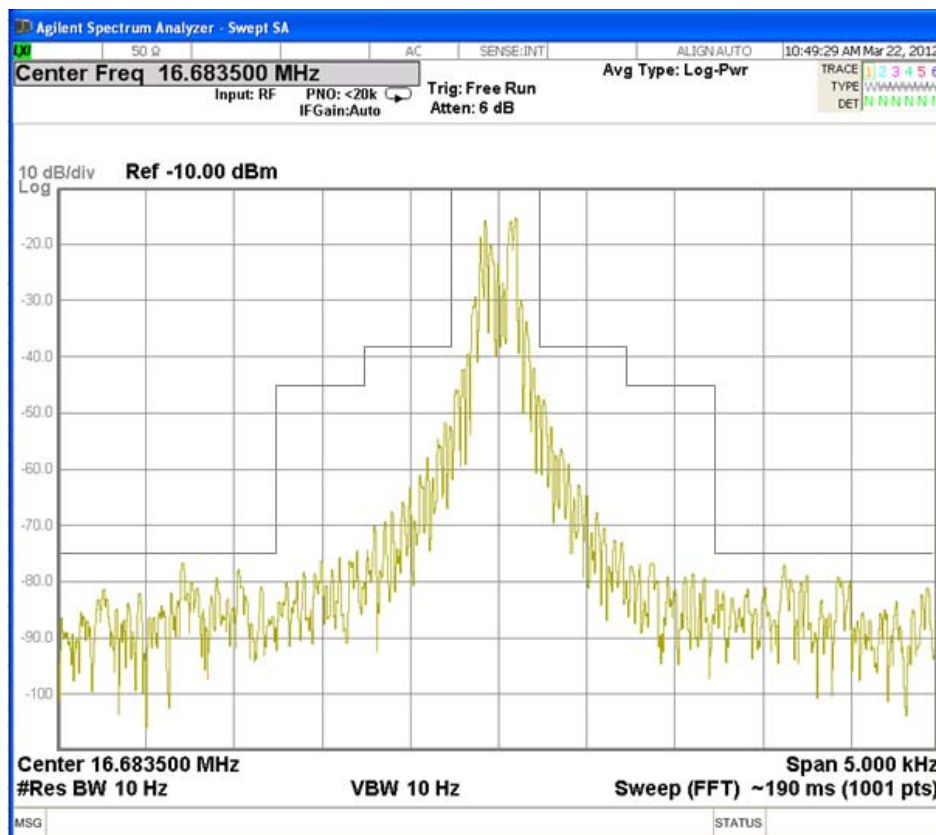

Fig. 3.3.27 NBDP(FEC): Tx Frequency 16683.5 kHz

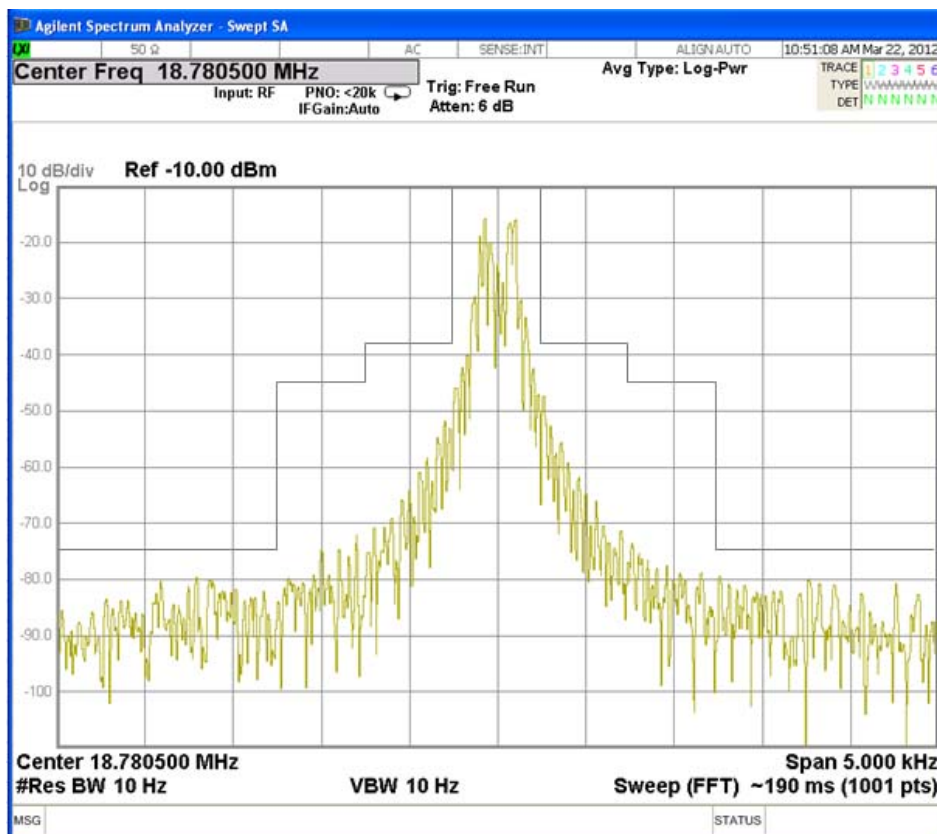

Fig. 3.3.28 NBDP(FEC): Tx Frequency 18870.5 kHz

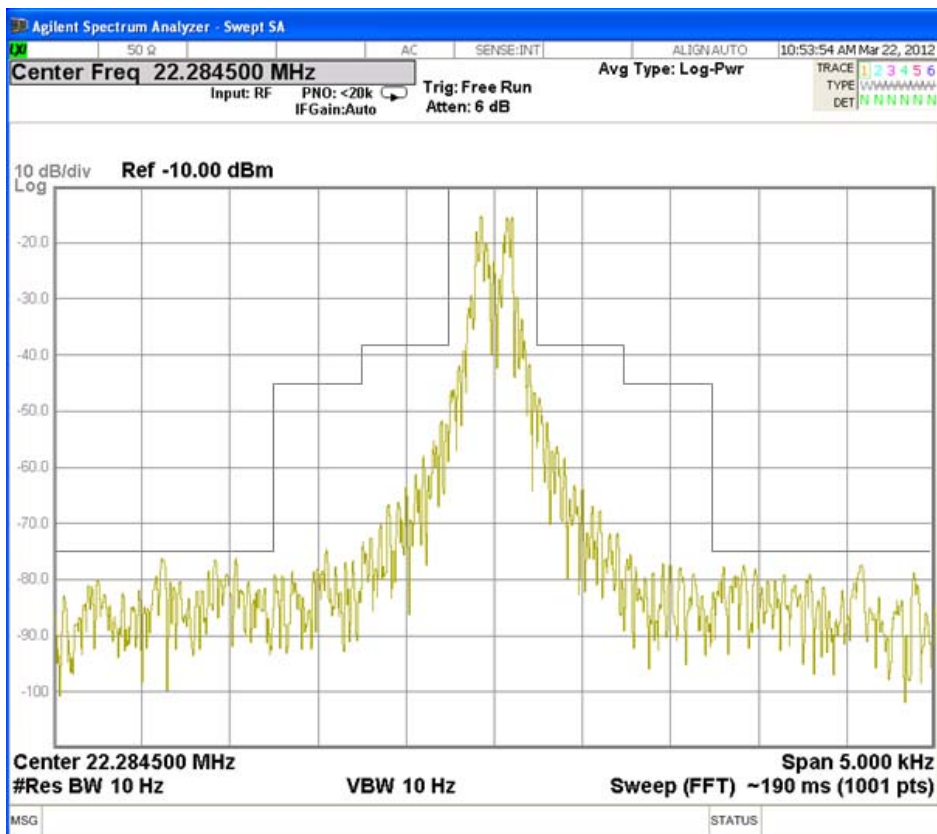

Fig. 3.3.29 NBDP(FEC): Tx Frequency 22284.5 kHz

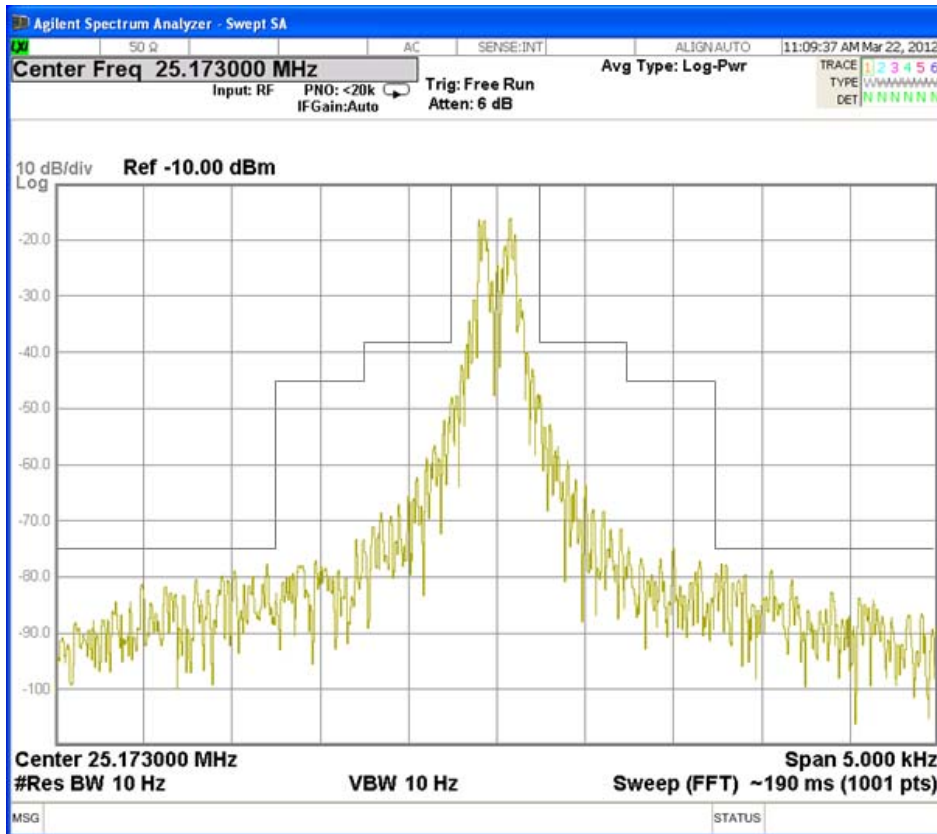

Fig. 3.3.30 NBDP(FEC): Tx Frequency 25173 kHz

3.4 Emission Limitations (FCC Rule Part 80.211)

(1) Method of Measurement

The FS-1575 was connected with measuring equipment as in Fig. 3.4.1.

The transmitter was modulated with 2 audio tones 400 Hz and 1800 Hz in equal level. The input level was adjusted to 10 dB above the level producing PEP output of 150 W.

Spectrum over the frequency range ±10 kHz of each test frequency was observed.

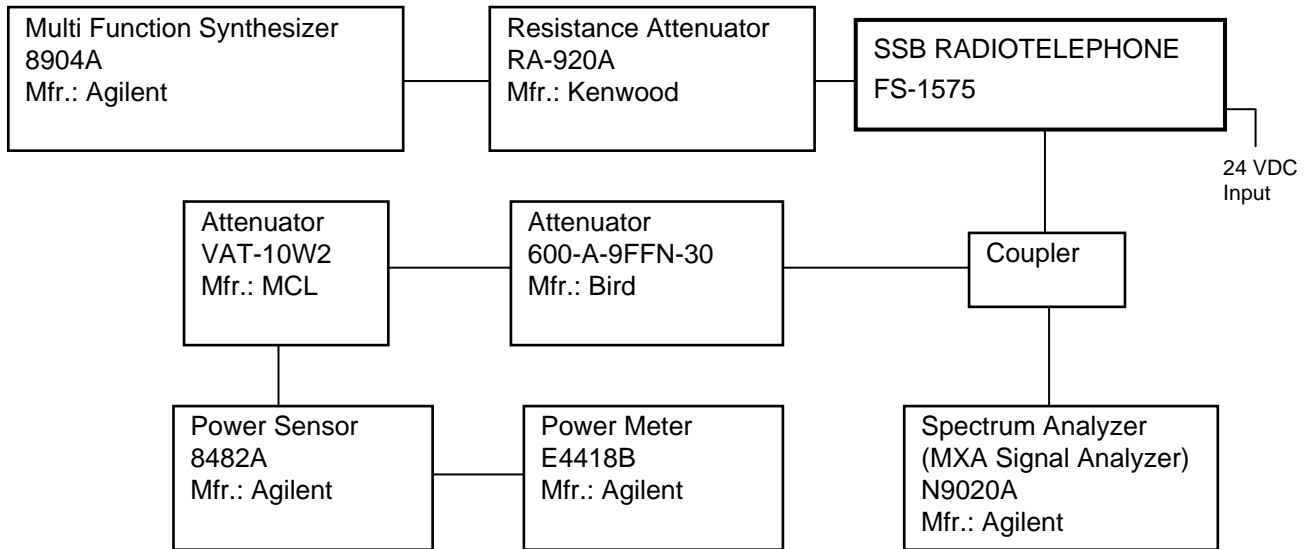

Fig. 3.4.1

Limit:

The emissions must be attenuated according to the following schedule.

- (a) The mean power when using emissions J3E:
 - (1) On any frequency removed from the assigned frequency by more than 50 percent up to and including 150 percent of the authorized bandwidth (*), at least 28 dB.
 - (2) On any frequency removed from the assigned frequency by more than 150 percent up to and including 250 percent of the authorized bandwidth (*): at least 35 dB; and
 - (3) On any frequency removed from the assigned frequency by more than 250 percent of the authorized bandwidth (*): at least 43 + 10 log₁₀ (mean power in watts) dB.

(*): Authorized bandwidth = SSB: 3 kHz, NBDP: 0.5 kHz

(2) Test Result

Passed.

Figures 3.4.2 through 3.4.30 are hardcopies of Spectrum Analyzer screen on each test frequency.

Environmental conditions observed: On 22 March 2012, 20°C to 23°C, 28% to 29%RH
24.0 VDC to 24.0 VDC

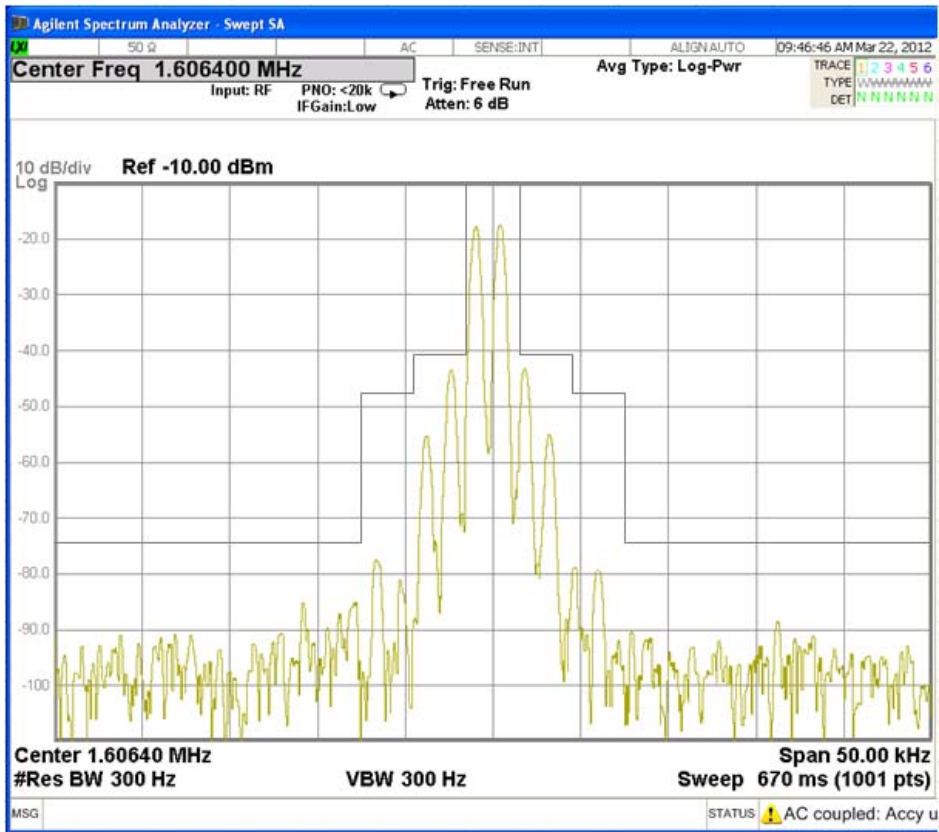

Fig. 3.4.2 SSB: Tx Frequency 1605 kHz

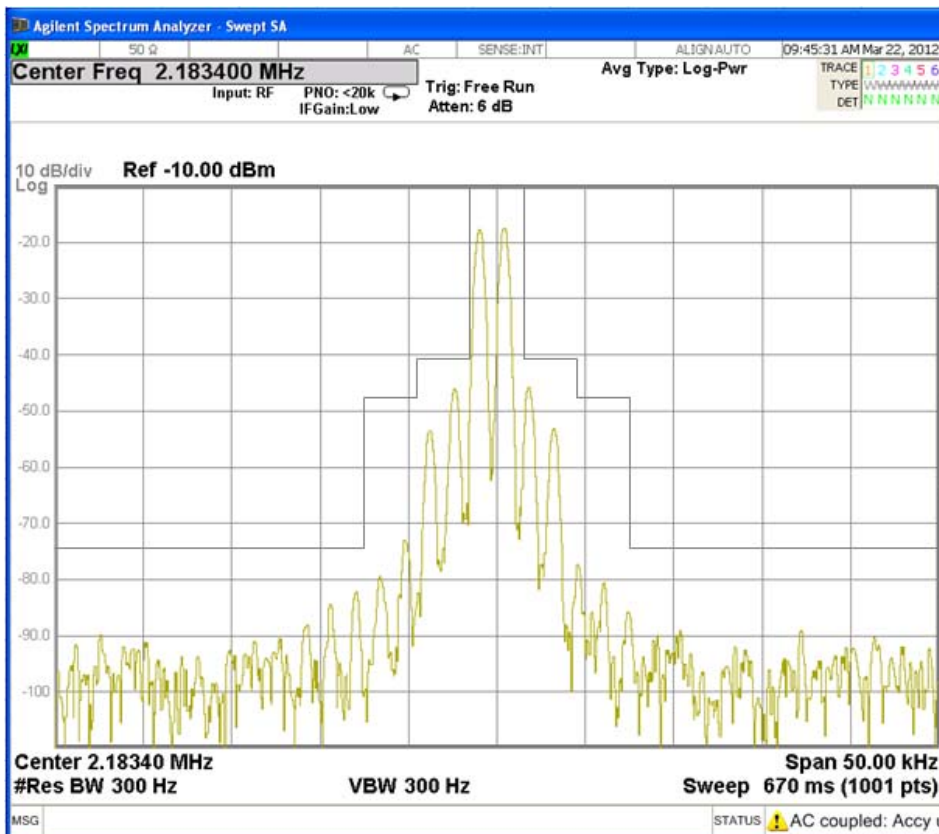

Fig. 3.4.3 SSB: Tx Frequency 2182 kHz

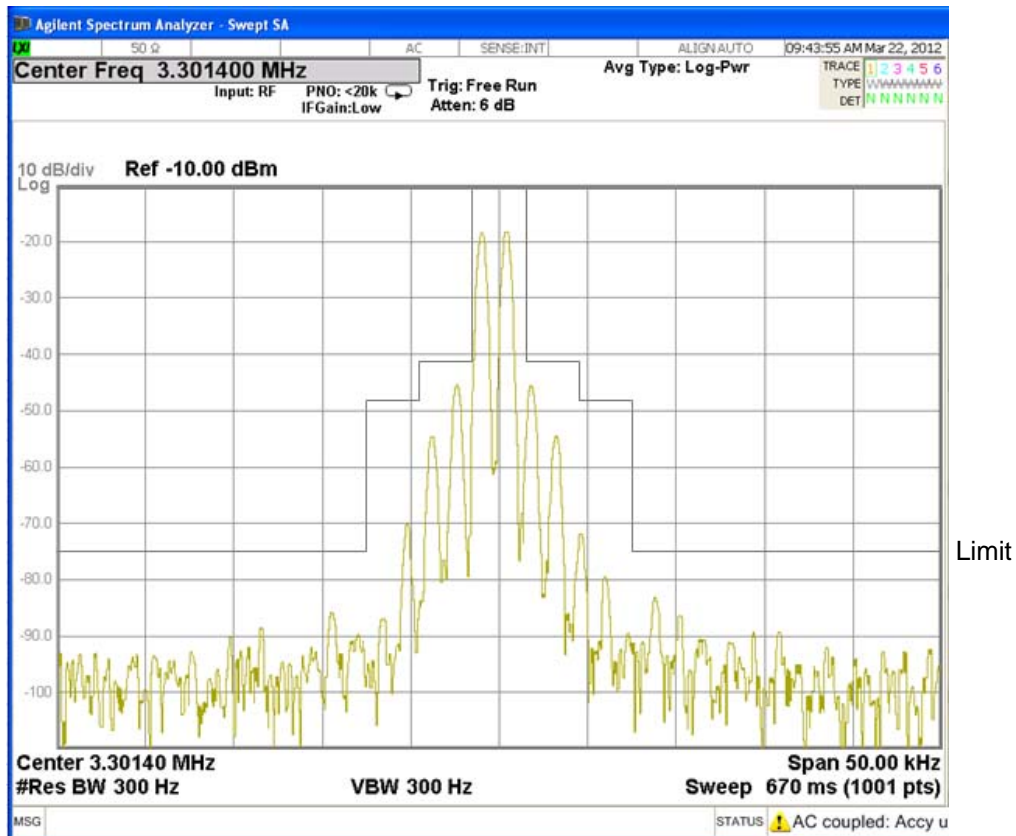

Fig. 3.4.4 SSB: Tx Frequency 3300 kHz

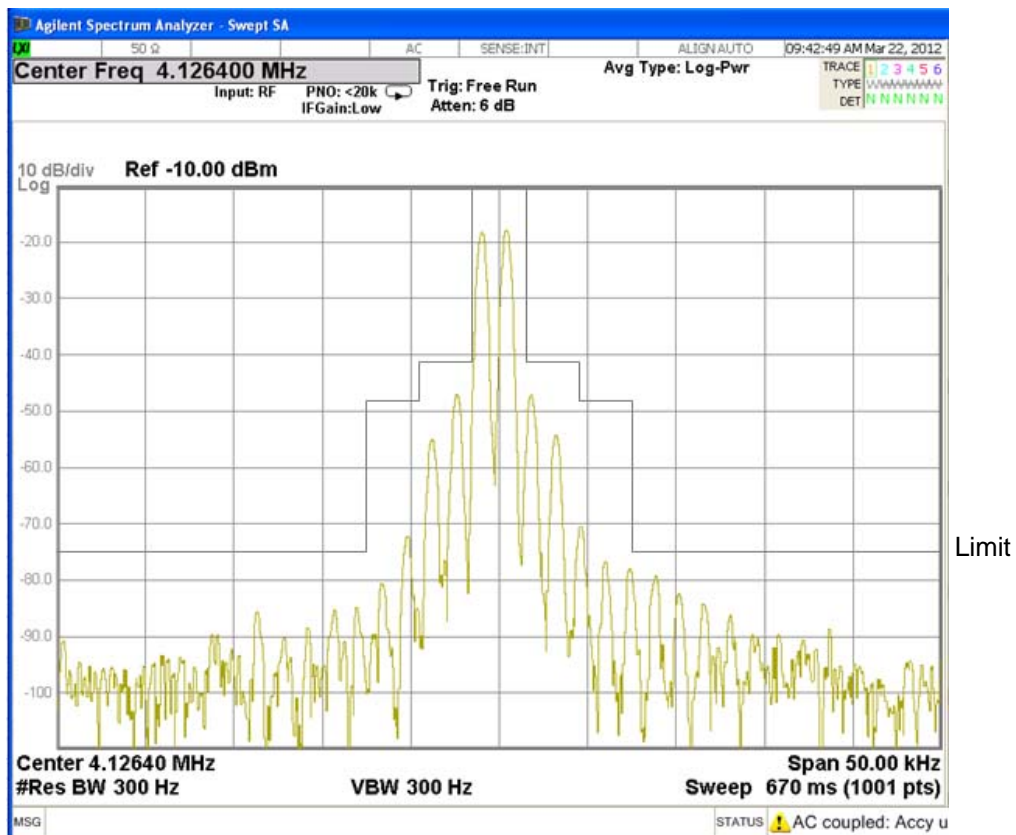
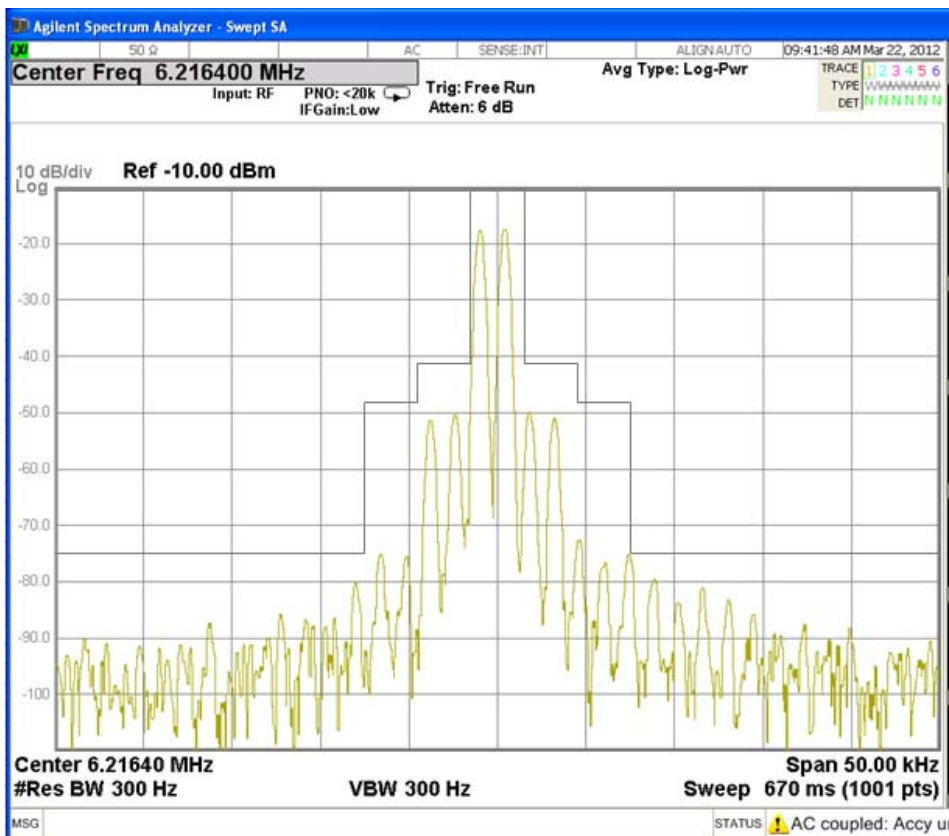
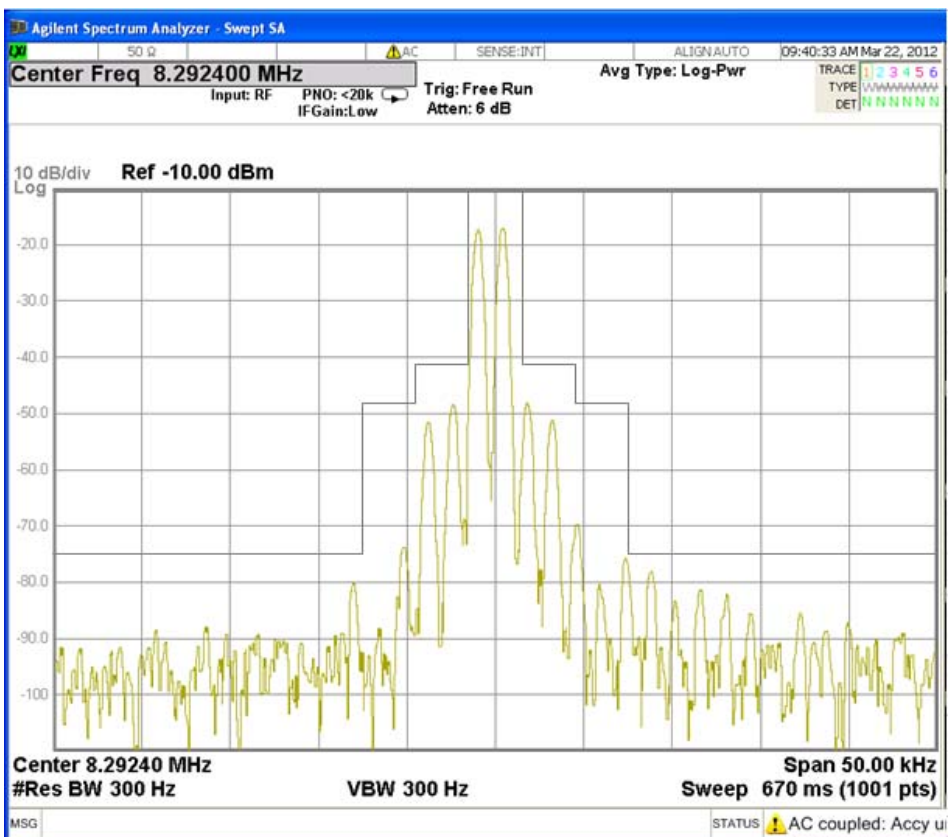

Fig. 3.4.5 SSB: Tx Frequency 4125 kHz



Limit

Fig. 3.4.6 SSB: Tx Frequency 6215 kHz



Limit

Fig. 3.4.7 SSB: Tx Frequency 8291 kHz

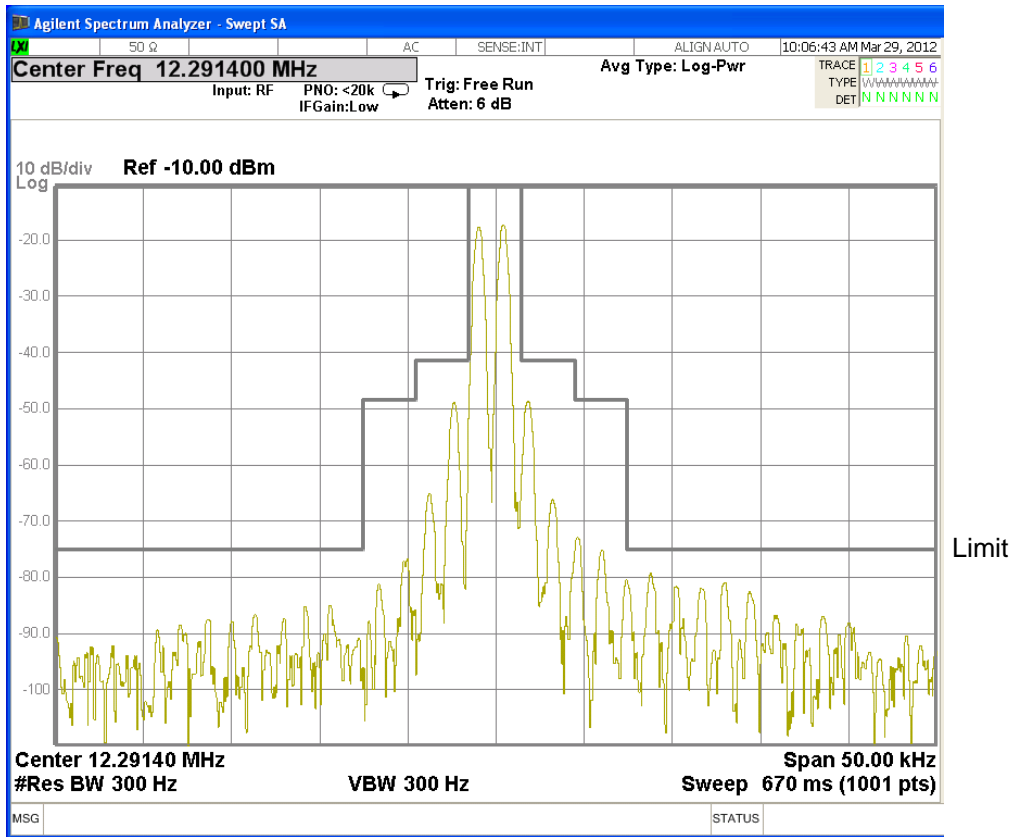

Fig. 3.4.8 SSB: Tx Frequency 12290 kHz

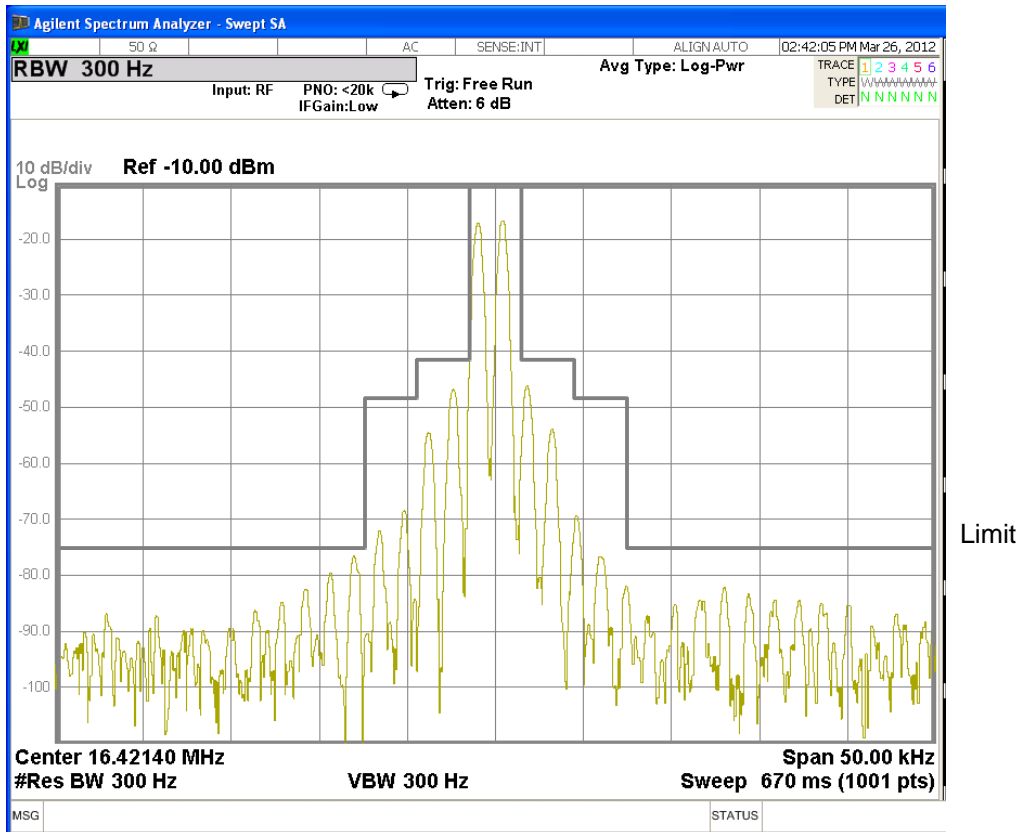

Fig. 3.4.9 SSB: Tx Frequency 16420 kHz

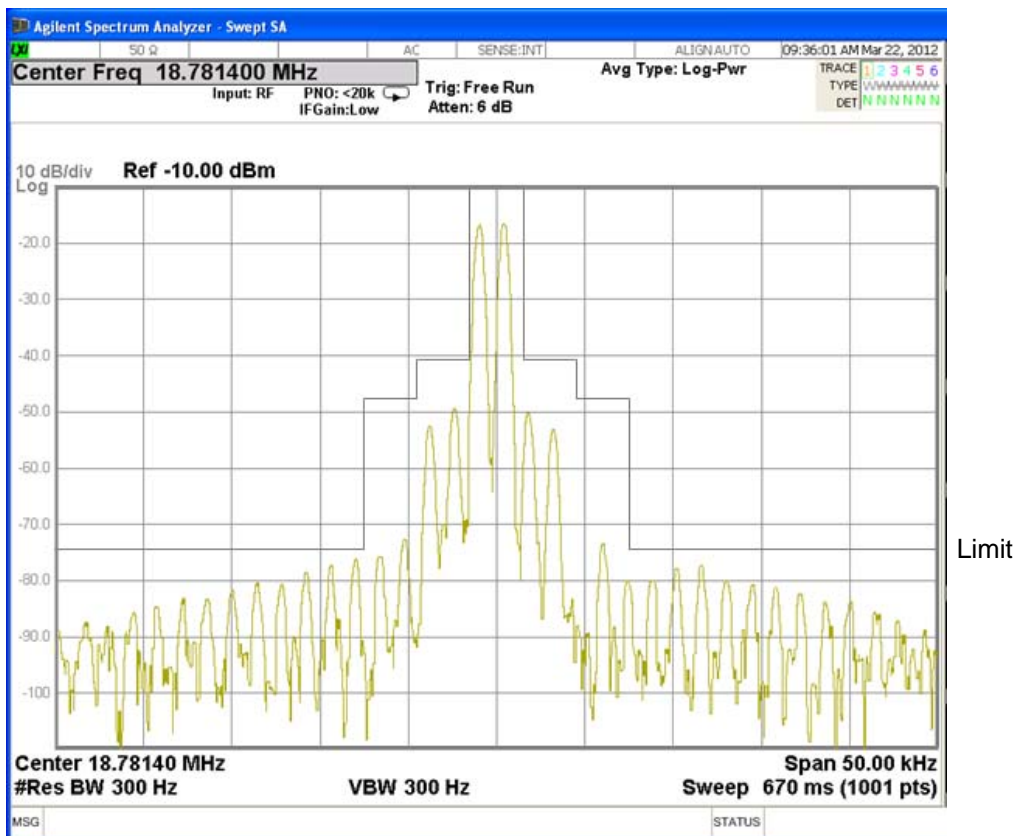

Fig. 3.4.10 SSB: Tx Frequency 18780 kHz

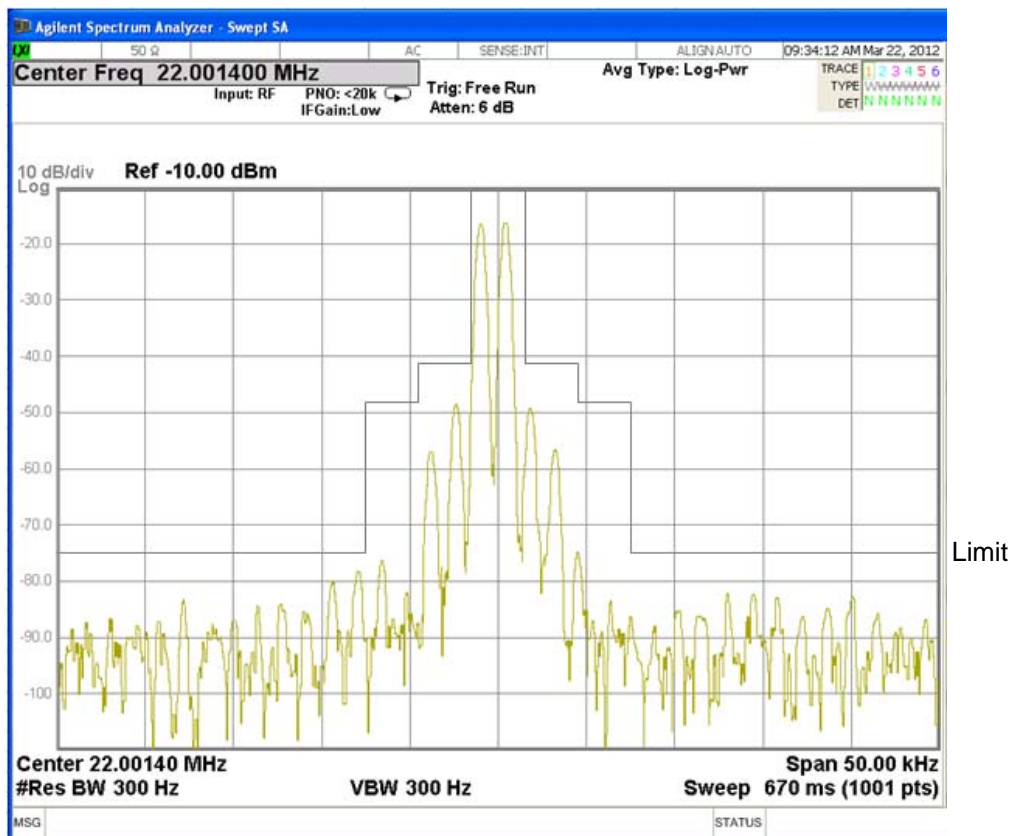

Fig. 3.4.11 SSB: Tx Frequency 22000 kHz

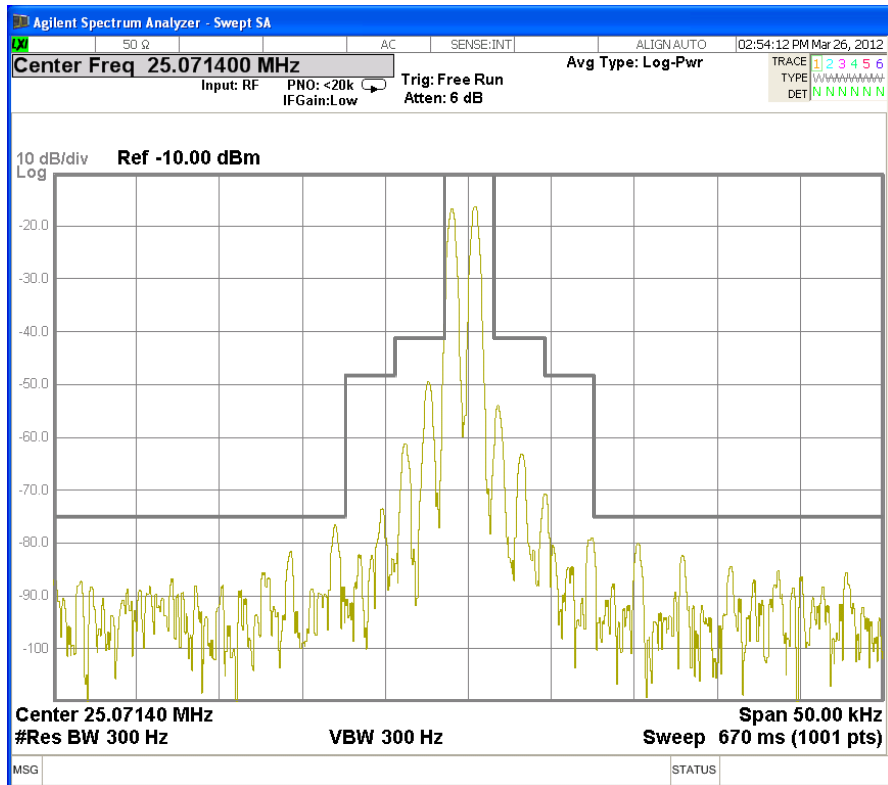

Fig. 3.4.12 SSB: Tx Frequency 25070 kHz

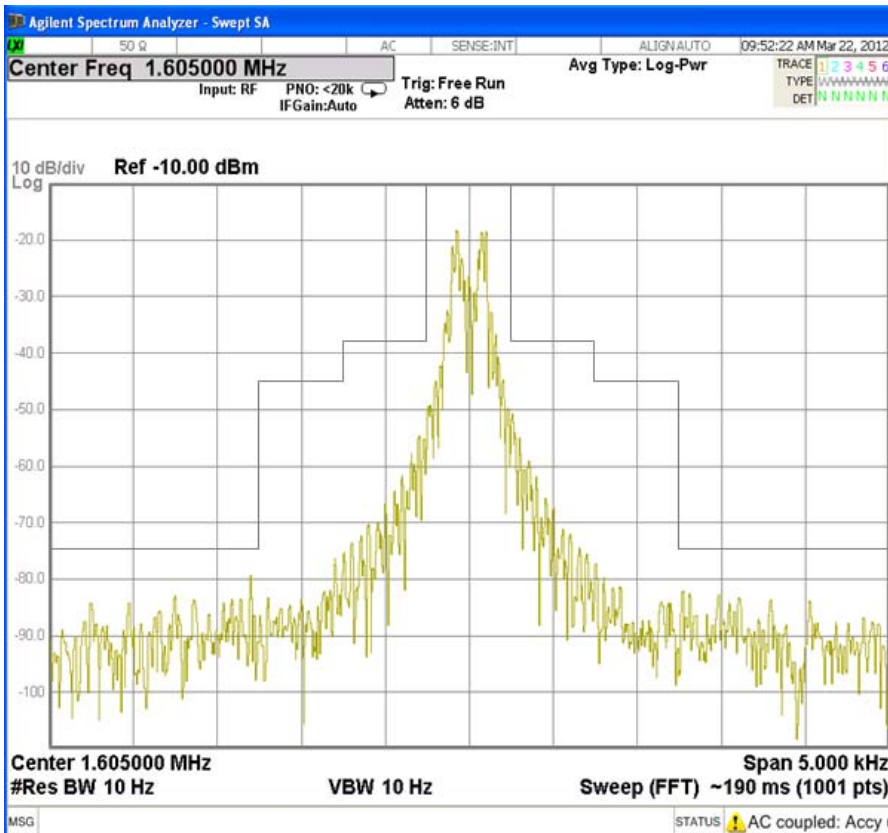
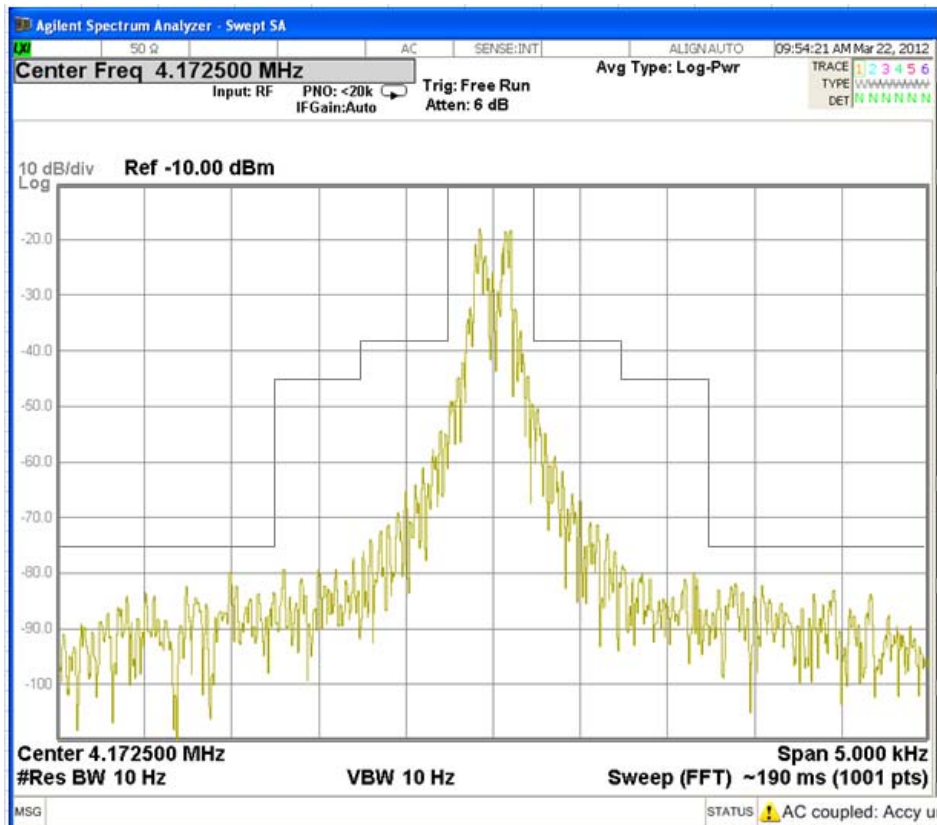
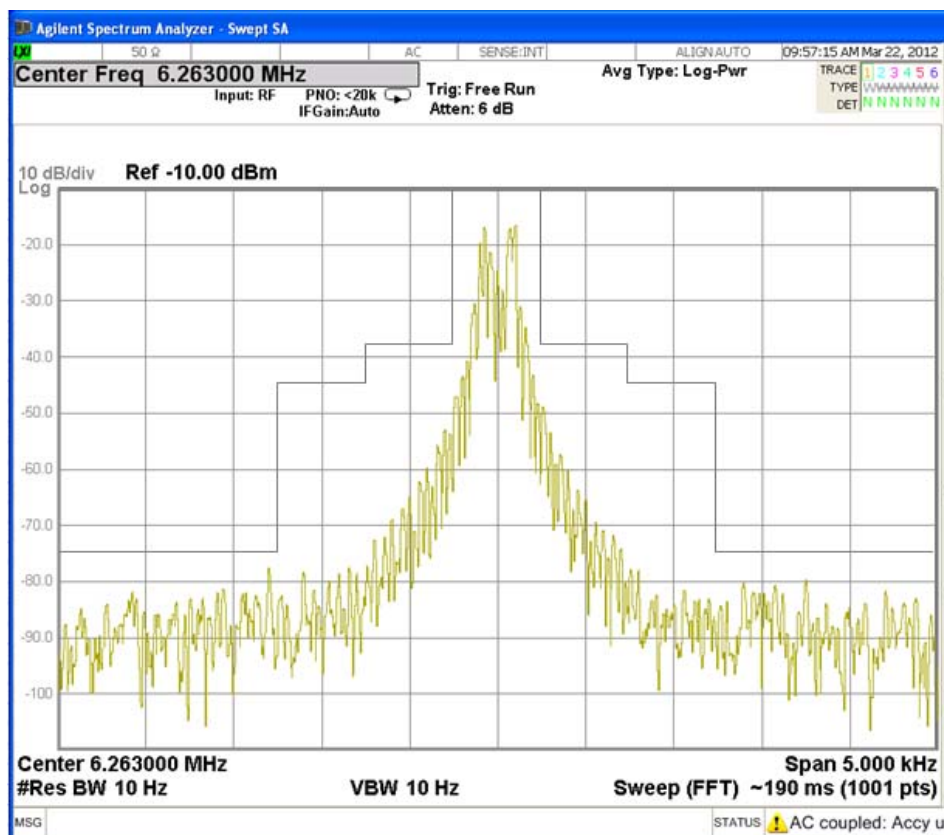

Fig. 3.4.13 NBDP(ARQ): Tx Frequency 1605 kHz



Limit

Fig. 3.4.14 NBDP(ARQ): Tx Frequency 4172.5 kHz



Limit

Fig. 3.4.15 NBDP(ARQ): Tx Frequency 6263 kHz

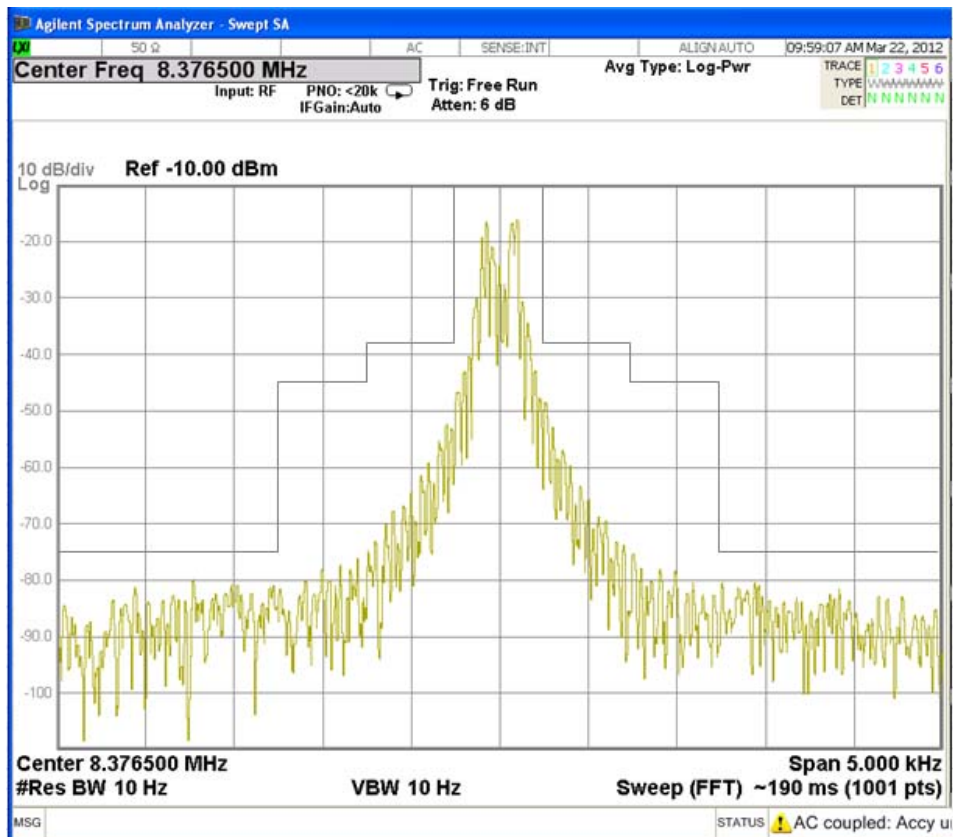

Limit

Fig. 3.4.16 NBDP(ARQ): Tx Frequency 8376.5 kHz

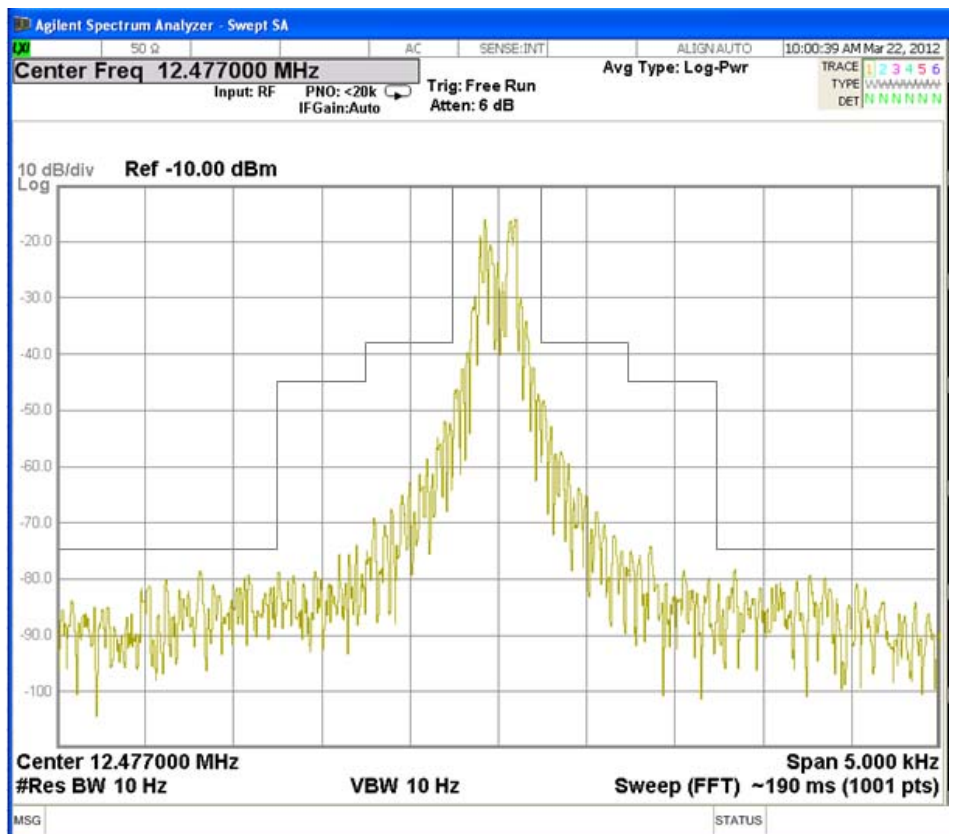

Limit

Fig. 3.4.17 NBDP(ARQ): Tx Frequency 12477 kHz

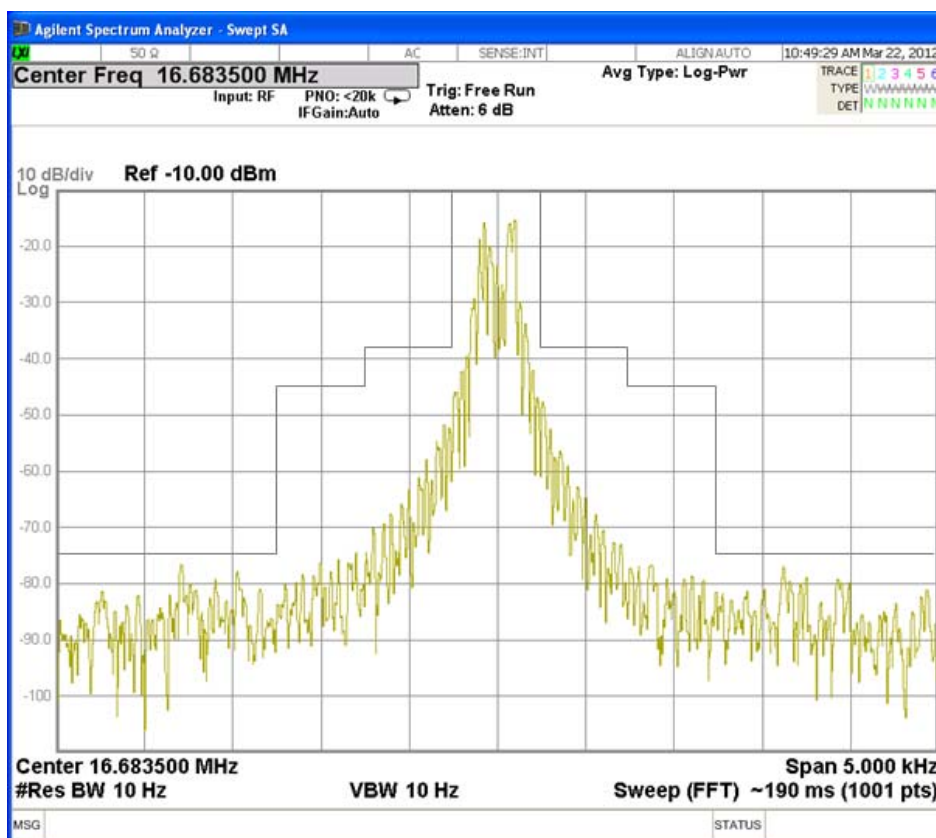

Fig. 3.4.18 NBDP(ARQ): Tx Frequency 16683.5 kHz

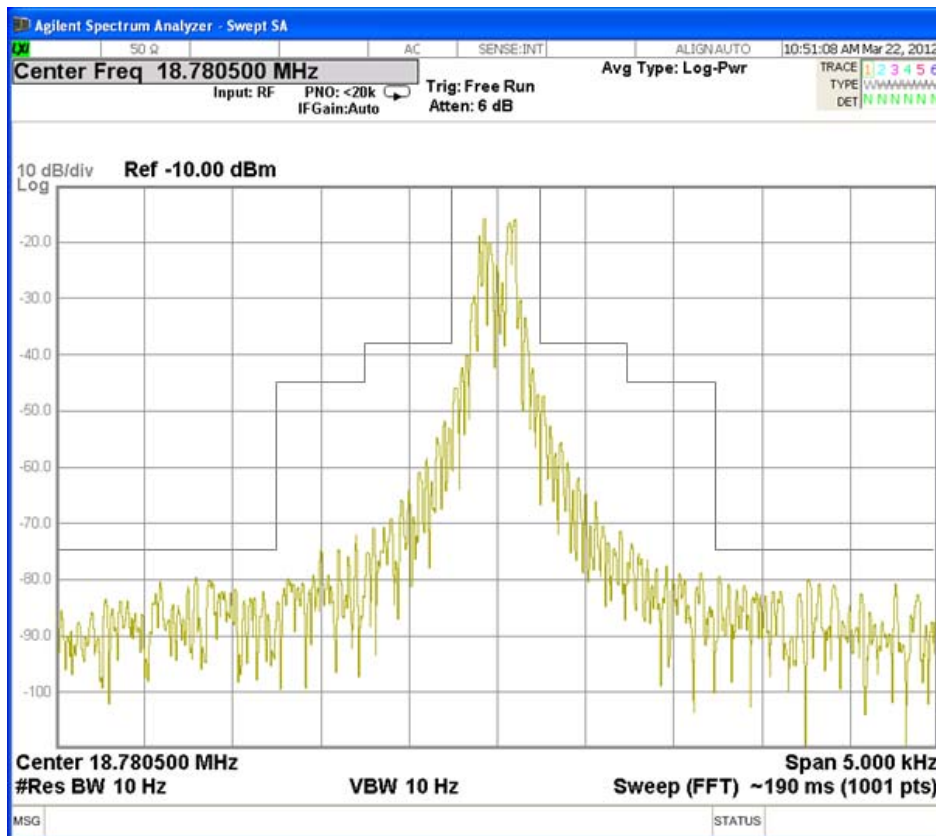

Fig. 3.4.19 NBDP(ARQ): Tx Frequency 18780.5 kHz

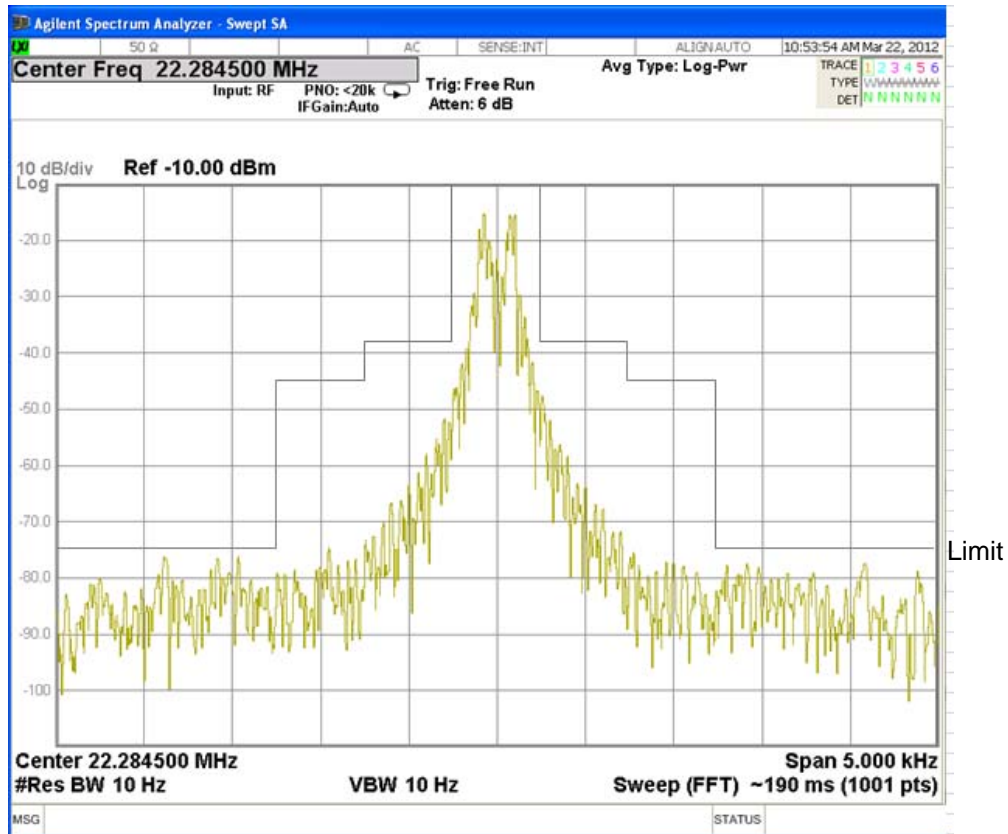

Fig. 3.4.20 NBDP(ARQ): Tx Frequency 22284.5 kHz

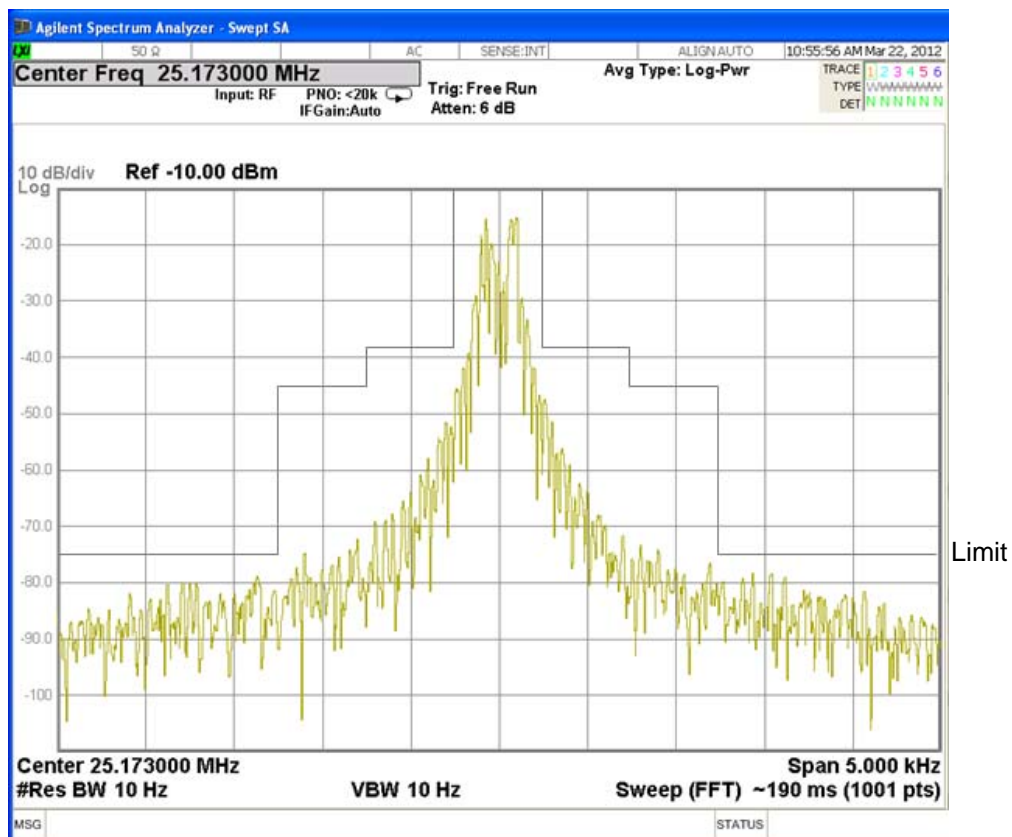

Fig. 3.4.21 NBDP(ARQ): Tx Frequency 25173 kHz

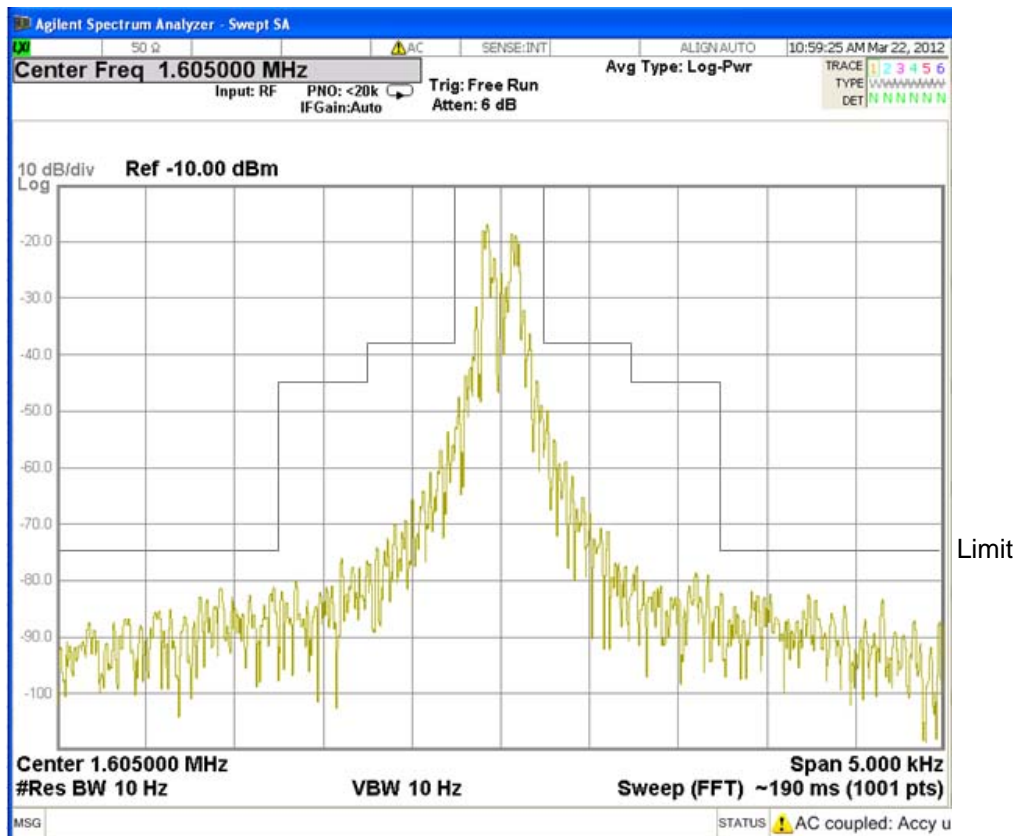

Fig. 3.4.22 NBDP(FEC): Tx Frequency 1605 kHz

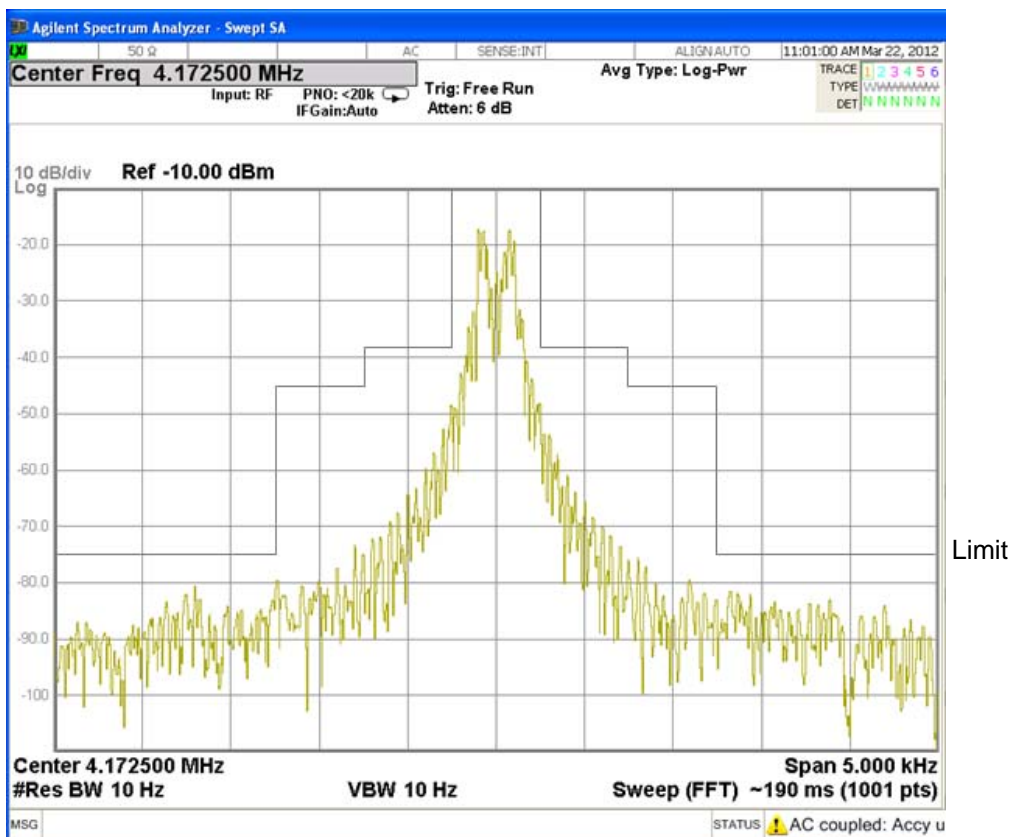
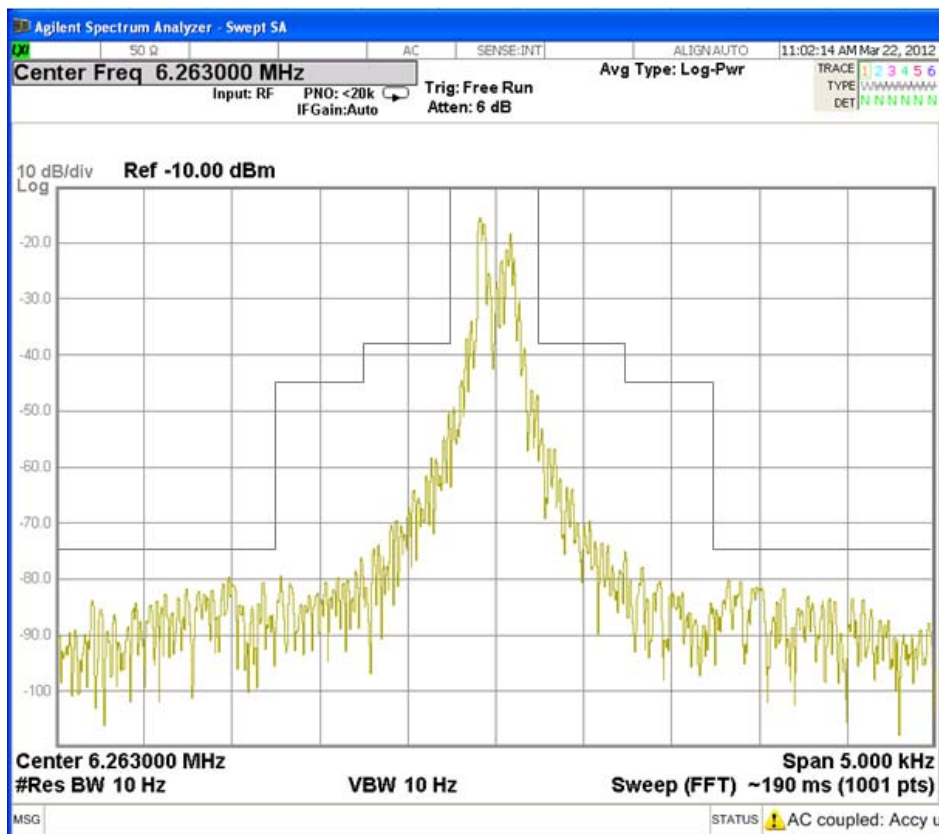
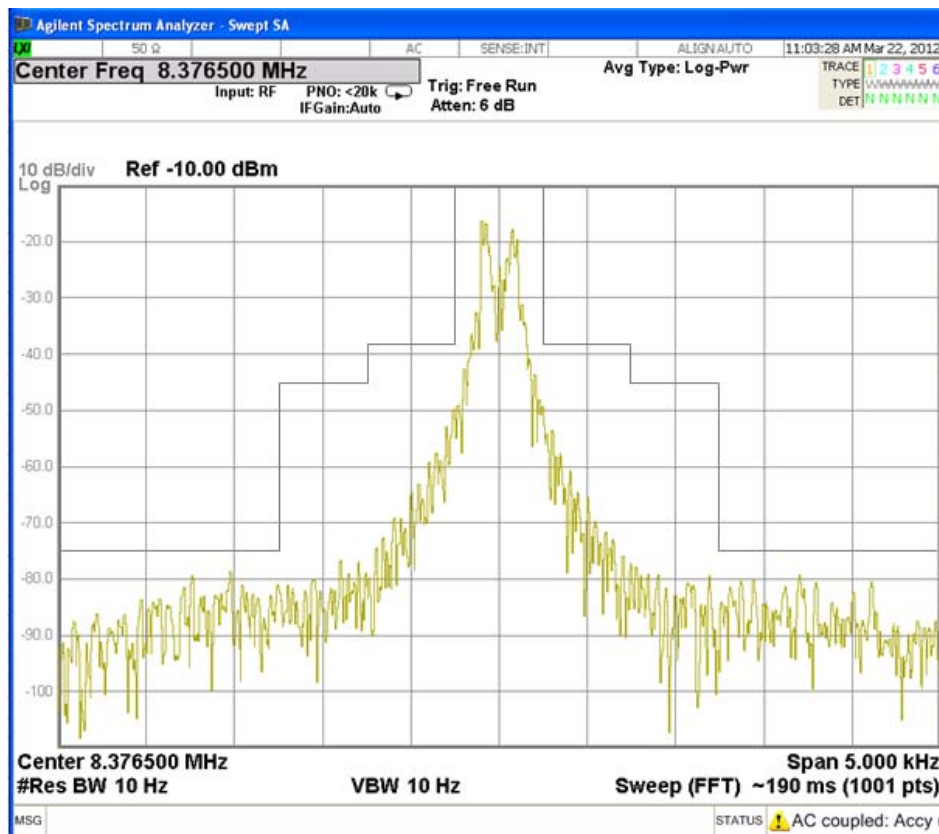

Fig. 3.4.23 NBDP(FEC): Tx Frequency 4172.5 kHz



Limit

Fig. 3.4.24 NBDP(FEC): Tx Frequency 6263 kHz



Limit

Fig. 3.4.25 NBDP(FEC): Tx Frequency 8376.5 kHz

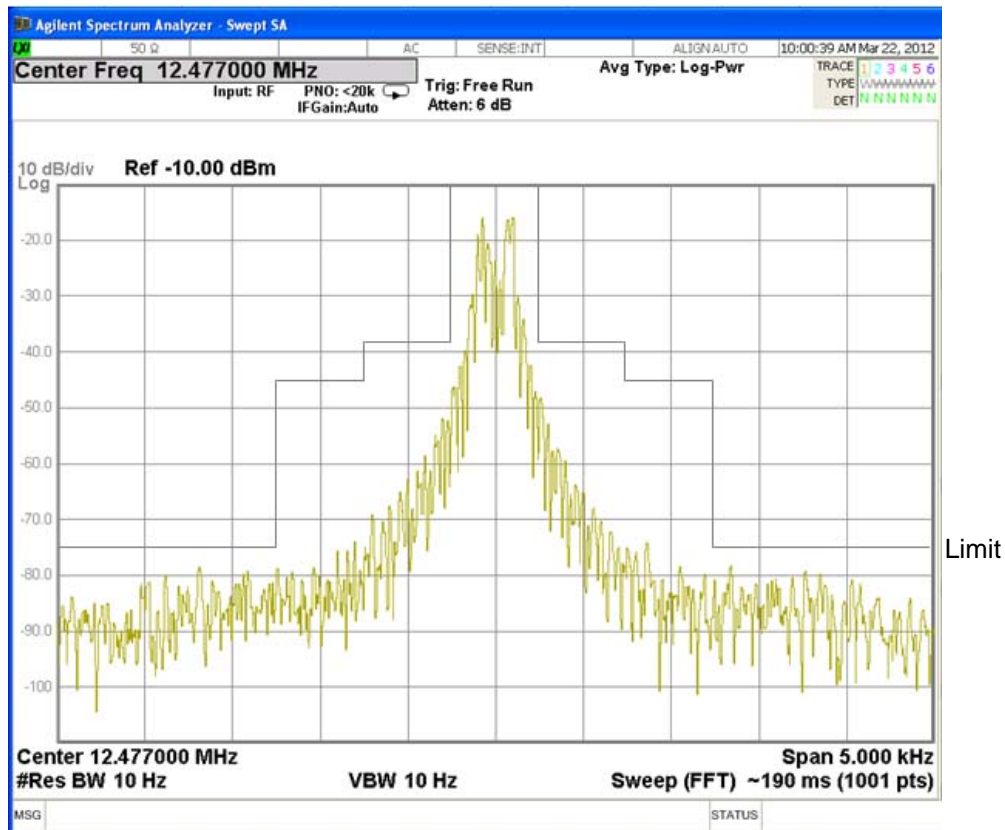

Fig. 3.4.26 NBDP(FEC): Tx Frequency 12477 kHz

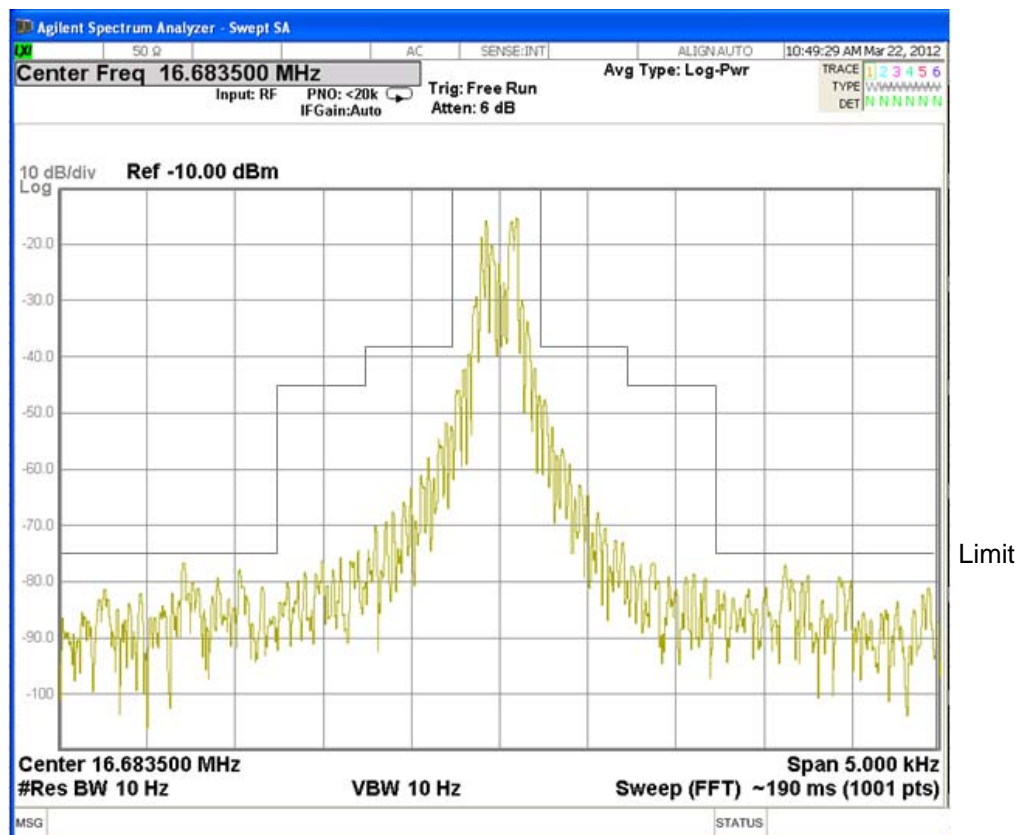

Fig. 3.4.27 NBDP(FEC): Tx Frequency 16683.5 kHz

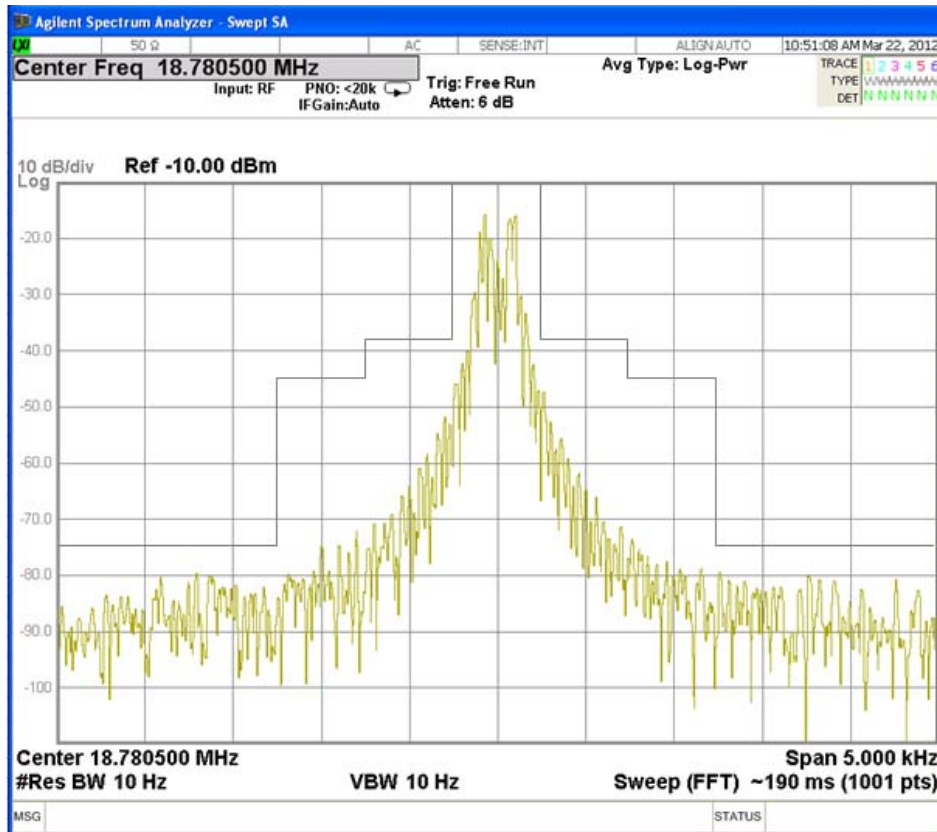

Fig. 3.4.28 NBDP(FEC): Tx Frequency 18870.5 kHz

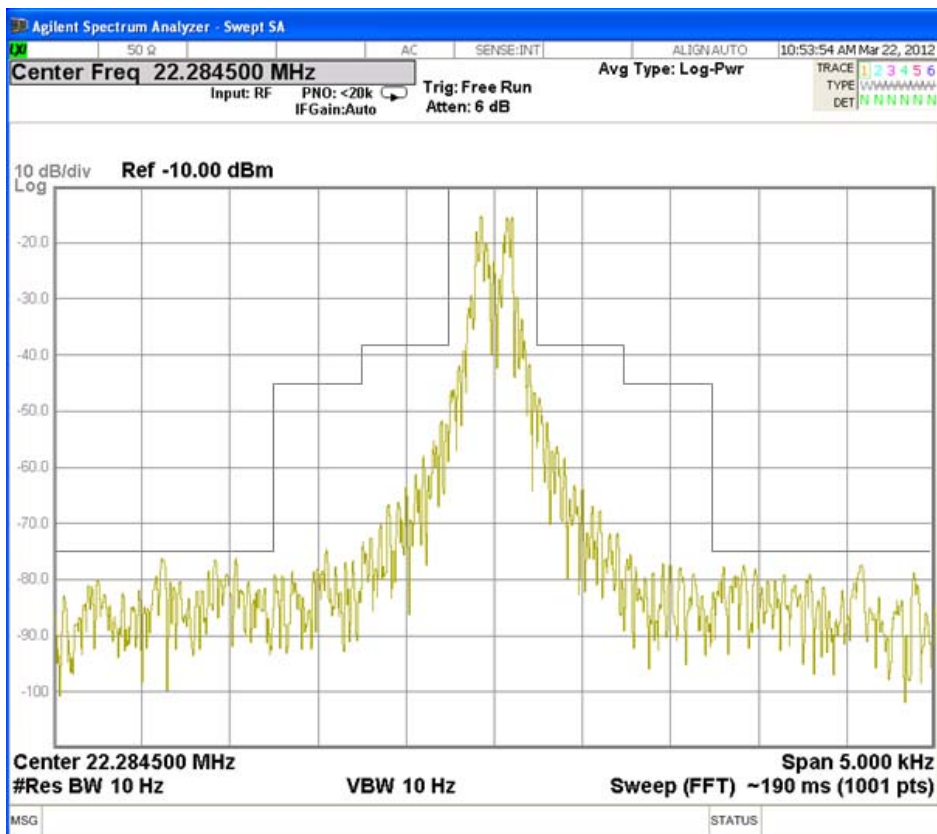

Fig. 3.4.29 NBDP(FEC): Tx Frequency 22284.5 kHz

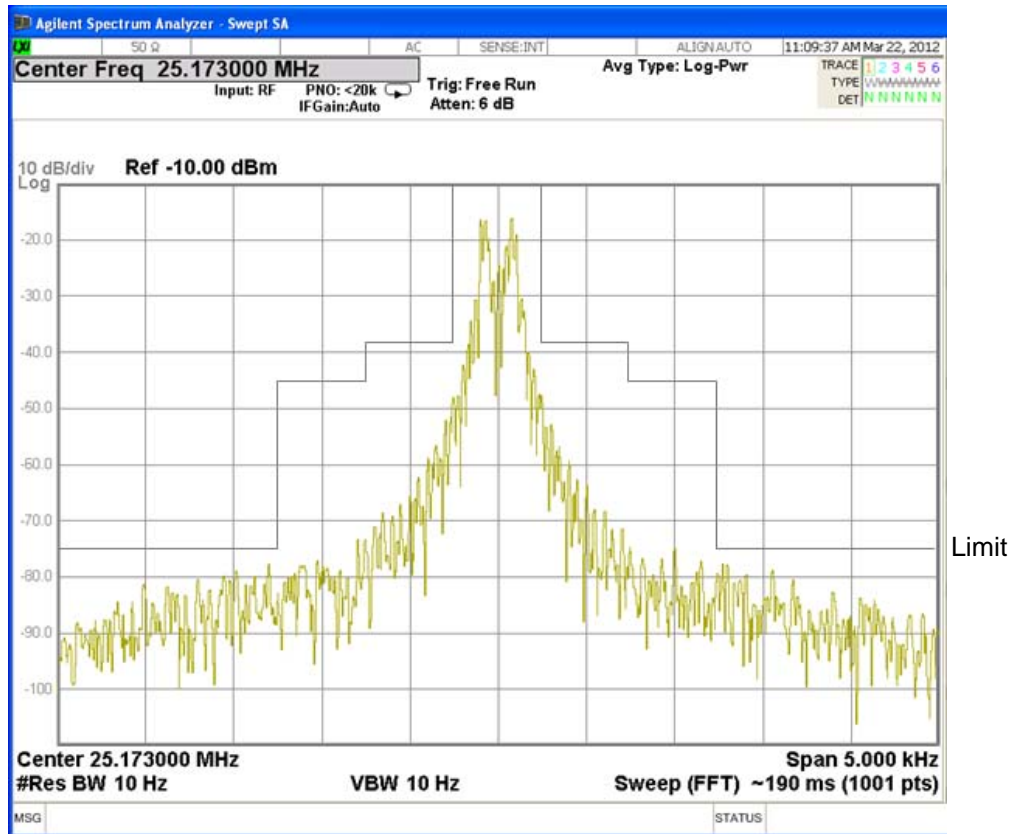

Fig. 3.4.30 NBDP(FEC): Tx Frequency 25173 kHz

3.5 Spurious Emissions at Antenna Terminal (FCC Rule Part 2.1051 & 80.211)

(1) Method of Measurement

The transmitter was connected with measuring equipment as in Fig. 3.5.1.

The transmitter was modulated with 2 audio tones 400 Hz and 1800 Hz in equal level. The input level was adjusted to 10 dB above the level producing PEP output of 150 W.

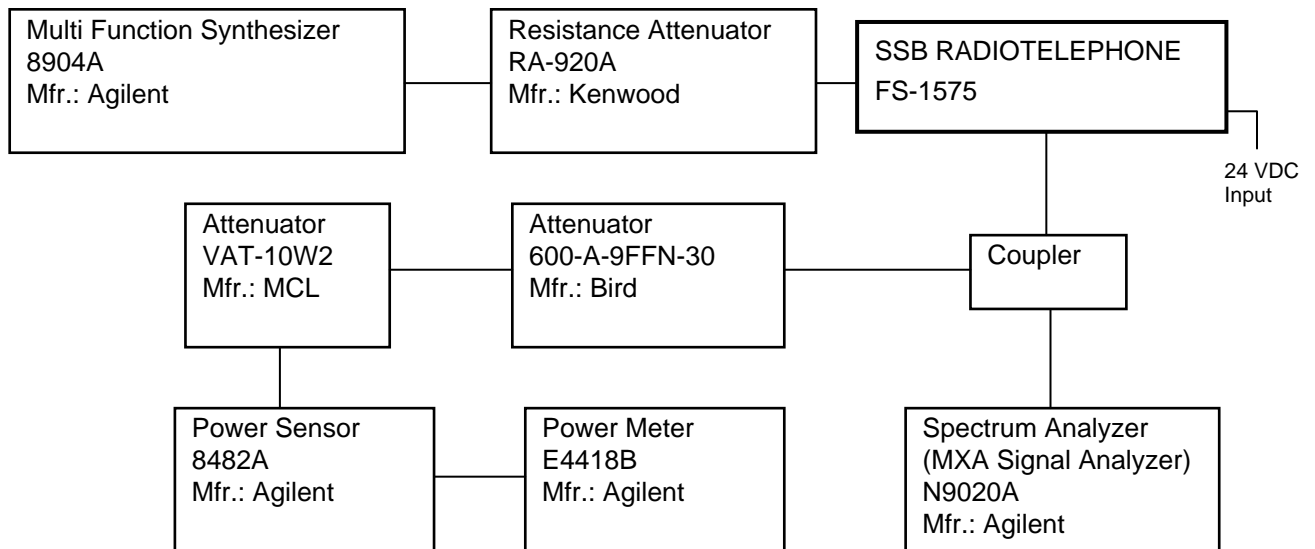

Fig. 3.5.1

Limit:

On any frequency removed from the assigned frequency by more than 250 percent of the authorized bandwidth: at least $43 + 10\log_{10}$ (mean power in watts) dB.

(2) Test Result

Passed.

Figures 3.5.2 through 3.5.22 are hardcopies of Spectrum Analyzer screen on each test frequency. On test frequencies above 3 MHz spectrum was observed with 2 sweep rates.

Environmental conditions observed: On 22 March 2012, 23°C to 24°C, 29% to 30%RH

24.0 VDC to 24.0 VDC

Spurious Emissions that were prominent were listed in Table 3.5.1 to 3.5.11

Table 3.5.1 Spurious emissions at antenna terminal of Tx-1605 kHz

Spurious frequency	Power of spurious emission (dBc)	Limit (dBc) (*2)	Margin (dB)
2 xFc (*1)	-83	-62	21
3 xFc	-76.0	-62	14.0
4 xFc	Not found	-62	N.A.
5 xFc	-80.0	-62	18.0
6 xFc	Not found	-62	N.A.
7 xFc	Not found	-62	N.A.
8 xFc	Not found	-62	N.A.
9 xFc	Not found	-62	N.A.
10 xFc	Not found	-62	N.A.

(*1) Fc: Carrier frequency

(*2) Limit: $-(43 + 10 \log(P_m)) = -(43 + 10\log(75)) = 62 \text{ dBc}$

Note: N.A.- Not applicable.

Table 3.5.2 Spurious emissions at antenna terminal of Tx-2182 kHz

Spurious frequency	Power of spurious emission (dBc)	Limit (dBc) (*2)	Margin (dB)
2 xFc (*1)	-84.0	-62	22.0
3 xFc	-83.0	-62	21.0
4 xFc	Not found	-62	N.A.
5 xFc	Not found	-62	N.A.
6 xFc	Not found	-62	N.A.
7 xFc	Not found	-62	N.A.
8 xFc	Not found	-62	N.A.
9 xFc	Not found	-62	N.A.
10 xFc	Not found	-62	N.A.

(*1) Fc: Carrier frequency

(*2) Limit: $-(43 + 10 \log(P_m)) = -(43 + 10\log(75)) = 62 \text{ dBc}$

Note: N.A.- Not applicable.

Table 3.5.3 Spurious emissions at antenna terminal of Tx-3300 kHz

Spurious frequency	Power of spurious emission (dBc)	Limit (dBc) (*2)	Margin (dB)
2 xFc (*1)	-78.0	-62	16.0
3 xFc	-80.0	-62	18.0
4 xFc	Not found	-62	N.A.
5 xFc	Not found	-62	N.A.
6 xFc	Not found	-62	N.A.
7 xFc	Not found	-62	N.A.
8 xFc	Not found	-62	N.A.
9 xFc	Not found	-62	N.A.
10 xFc	Not found	-62	N.A.

(*1) Fc: Carrier frequency

(*2) Limit: $-(43 + 10 \log(P_m)) = -(43 + 10 \log(75)) = 62 \text{ dBc}$

Note: N.A.- Not applicable.

Table 3.5.4 Spurious emissions at antenna terminal of Tx-4125 kHz

Spurious frequency	Power of spurious emission (dBc)	Limit (dBc) (*2)	Margin (dB)
2 xFc (*1)	-68.0	-62	6.0
3 xFc	-71.8	-62	9.8
4 xFc	Not found	-62	N.A.
5 xFc	-87.1	-62	25.1
6 xFc	Not found	-62	N.A.
7 xFc	Not found	-62	N.A.
8 xFc	Not found	-62	N.A.
9 xFc	Not found	-62	N.A.
10 xFc	Not found	-62	N.A.

(*1) Fc: Carrier frequency

(*2) Limit: $-(43 + 10 \log(P_m)) = -(43 + 10 \log(75)) = 62 \text{ dBc}$

Note: N.A.- Not applicable.

Table 3.5.5 Spurious emissions at antenna terminal of Tx-6125 kHz

Spurious frequency	Power of spurious emission (dBc)	Limit (dBc) (*2)	Margin (dB)
2 xFc (*1)	-71.0	-62	9.0
3 xFc	-77.0	-62	15.0
4 xFc	-88.8	-62	26.6
5 xFc	-84.5	-62	22.5
6 xFc	-84.3	-62	22.3
7 xFc	-85.8	-62	23.8
8 xFc	Not found	-62	N.A.
9 xFc	-88.0	-62	16.0
10 xFc	Not found	-62	N.A.

(*1) Fc: Carrier frequency

(*2) Limit: $-(43 + 10 \log(P_m)) = -(43 + 10 \log(75)) = 62 \text{ dBc}$

Note: N.A.- Not applicable.

Table 3.5.6 Spurious emissions at antenna terminal of Tx-8291 kHz

Spurious frequency	Power of spurious emission (dBc)	Limit (dBc) (*2)	Margin (dB)
2 xFc (*1)	-71.8	-62	9.8
3 xFc	-70.4	-62	8.4
4 xFc	Not found	-62	N.A.
5 xFc	-77.8	-62	15.8
6 xFc	Not found	-62	N.A.
7 xFc	Not found	-62	N.A.
8 xFc	Not found	-62	N.A.
9 xFc	Not found	-62	N.A.
10 xFc	Not found	-62	N.A.

(*1) Fc: Carrier frequency

(*2) Limit: $-(43 + 10 \log(P_m)) = -(43 + 10 \log(75)) = 62 \text{ dBc}$

Note: N.A.- Not applicable.

Table 3.5.7 Spurious emissions at antenna terminal of Tx-12290 kHz

Spurious frequency	Power of spurious emission (dBc)	Limit (dBc) (*2)	Margin (dB)
2 xFc (*1)	-78.9	-62	16.9
3 xFc	-81.5	-62	19.5
4 xFc	-78.8	-62	16.8
5 xFc	-82.0	-62	20.0
6 xFc	-83.5	-62	21.5
7 xFc	-73.7	-62	11.7
8 xFc	-86.0	-62	24.0
9 xFc	-83.5	-62	21.5
10 xFc	Not found	-62	N.A.

(*1) Fc: Carrier frequency

(*2) Limit: $-(43 + 10 \log(P_m)) = -(43 + 10 \log(75)) = 62 \text{ dBc}$

Note: N.A.- Not applicable.

Table 3.5.8 Spurious emissions at antenna terminal of Tx-16420 kHz

Spurious frequency	Power of spurious emission (dBc)	Limit (dBc) (*2)	Margin (dB)
2 xFc (*1)	-74.2	-62	12.2
3 xFc	-74.2	-62	12.2
4 xFc	-77.0	-62	15.0
5 xFc	Not found	-62	N.A.
6 xFc	Not found	-62	N.A.
7 xFc	Not found	-62	N.A.
8 xFc	Not found	-62	N.A.
9 xFc	Not found	-62	N.A.
10 xFc	Not found	-62	N.A.

(*1) Fc: Carrier frequency

(*2) Limit: $-(43 + 10 \log(P_m)) = -(43 + 10 \log(75)) = 62 \text{ dBc}$

Note: N.A.- Not applicable.

Table 3.5.9 Spurious emissions at antenna terminal of Tx-18780 kHz

Spurious frequency	Power of spurious emission (dBc)	Limit (dBc) (*2)	Margin (dB)
2 xFc (*1)	-74.1	-62	12.1
3 xFc	-71.2	-62	9.2
4 xFc	Not found	-62	N.A.
5 xFc	-77.6	-62	15.6
6 xFc	Not found	-62	N.A.
7 xFc	Not found	-62	N.A.
8 xFc	Not found	-62	N.A.
9 xFc	Not found	-62	N.A.
10 xFc	Not found	-62	N.A.

(*1) Fc: Carrier frequency

(*2) Limit: $-(43 + 10 \log(P_m)) = -(43 + 10 \log(75)) = 62 \text{ dBc}$

Note: N.A.- Not applicable.

Table 3.5.10 Spurious emissions at antenna terminal of Tx-22000 kHz

Spurious frequency	Power of spurious emission (dBc)	Limit (dBc) (*2)	Margin (dB)
2 xFc (*1)	-72.2	-62	10.2
3 xFc	-69.4	-62	7.4
4 xFc	-86.5	-62	24.5
5 xFc	Not found	-62	N.A.
6 xFc	Not found	-62	N.A.
7 xFc	-83.0	-62	21.0
8 xFc	-83.5	-62	21.5
9 xFc	Not found	-62	N.A.
10 xFc	Not found	-62	N.A.

(*1) Fc: Carrier frequency

(*2) Limit: $-(43 + 10 \log(P_m)) = -(43 + 10 \log(75)) = 62 \text{ dBc}$

Note: N.A.- Not applicable.

Table 3.5.11 Spurious emissions at antenna terminal of Tx-25070 kHz

Spurious frequency	Power of spurious emission (dBc)	Limit (dBc) (*2)	Margin (dB)
2 xFc (*1)	-70.0	-62	8.0
3 xFc	-69.4	-62	7.4
4 xFc	-76.7	-62	14.7
5 xFc	-82.5	-62	20.5
6 xFc	Not found	-62	N.A.
7 xFc	-84.0	-62	22.0
8 xFc	Not found	-62	N.A.
9 xFc	Not found	-62	N.A.
10 xFc	Not found	-62	N.A.

(*1) Fc: Carrier frequency

(*2) Limit: $-(43 + 10 \log(P_m)) = -(43 + 10 \log(125)) = 62 \text{ dBc}$

Note: N.A.- Not applicable.

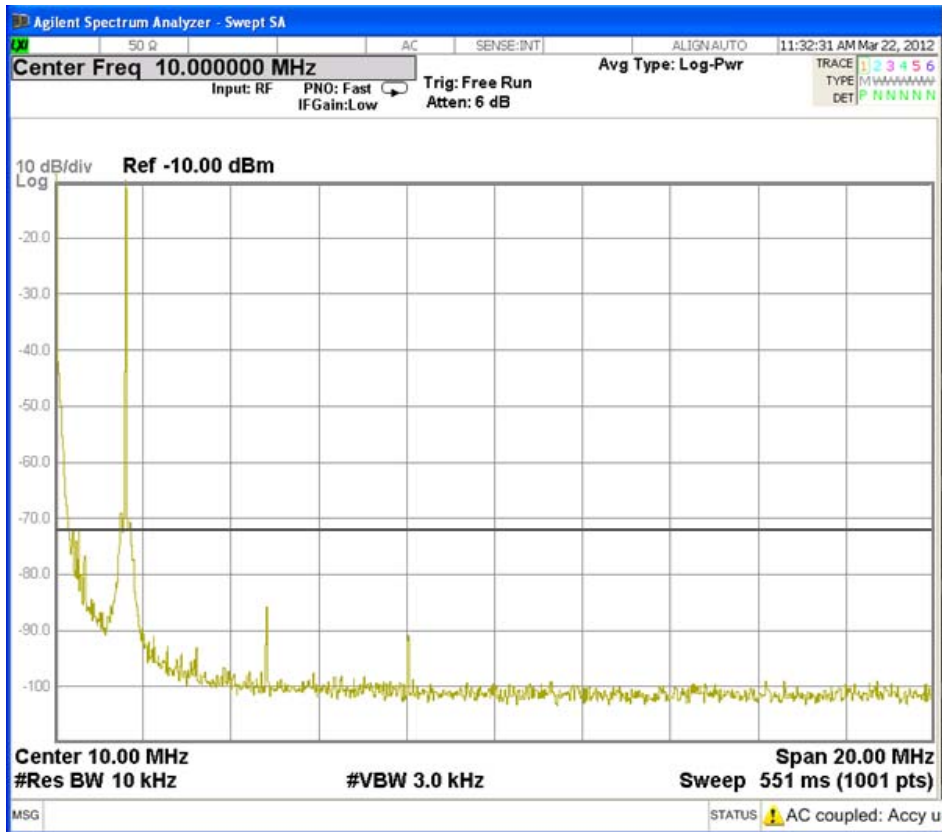

Fig. 3.5.2 Tx Frequency 1605 kHz

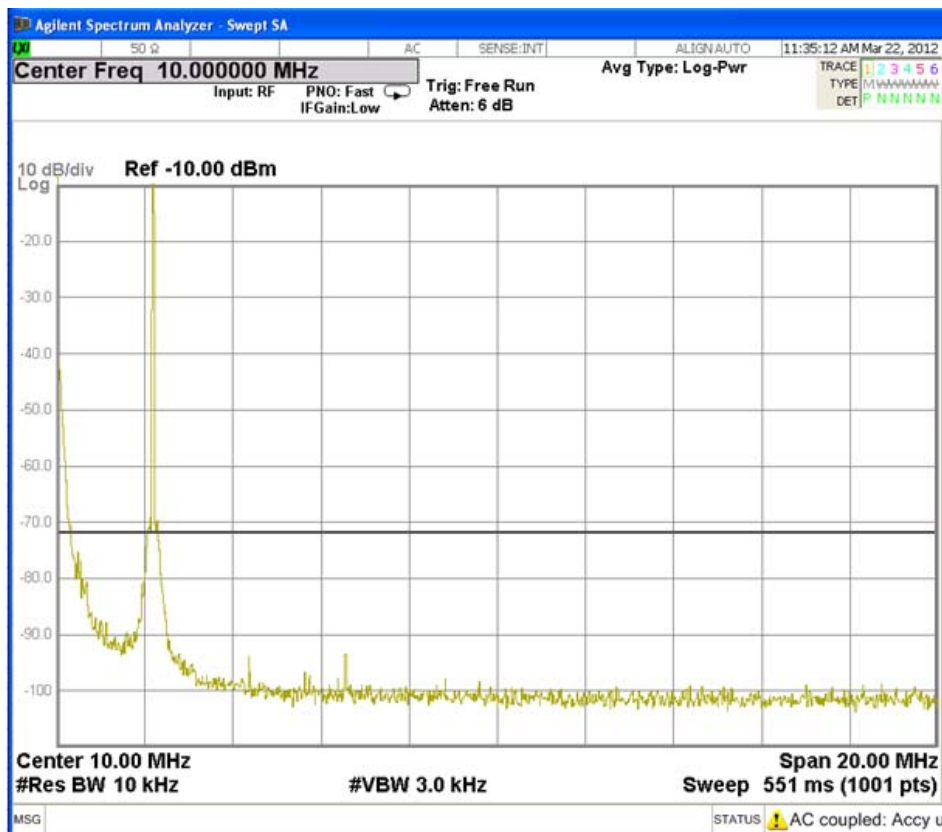

Fig. 3.5.3 Tx Frequency 2182 kHz

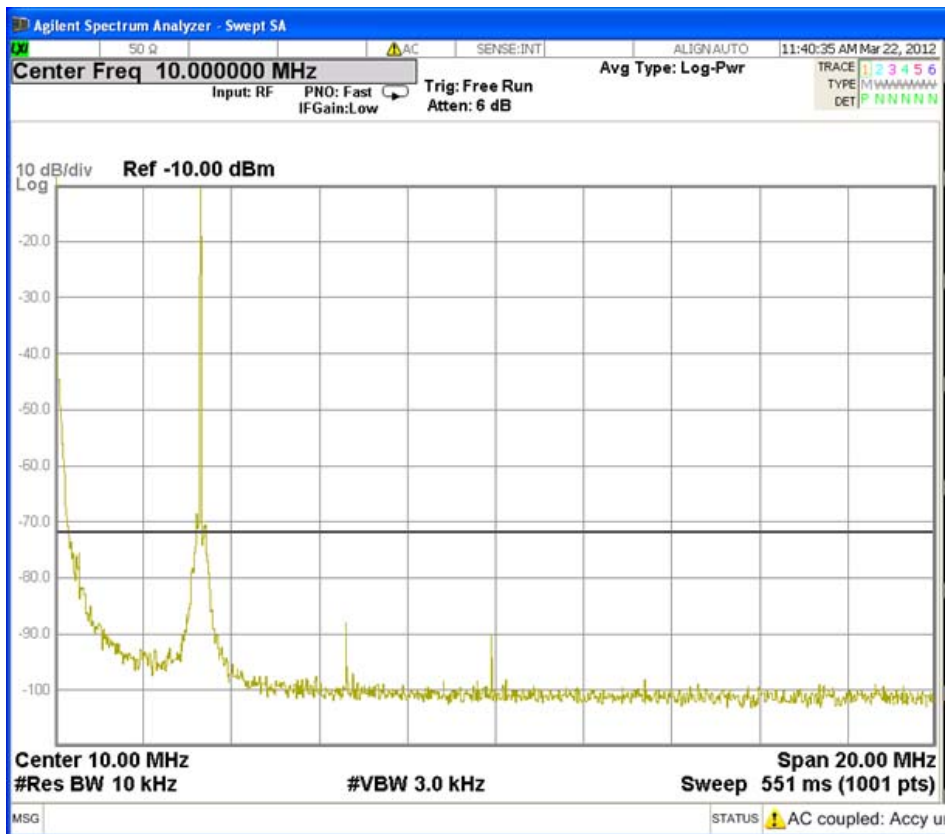

Fig. 3.5.4 Tx Frequency 3300 kHz

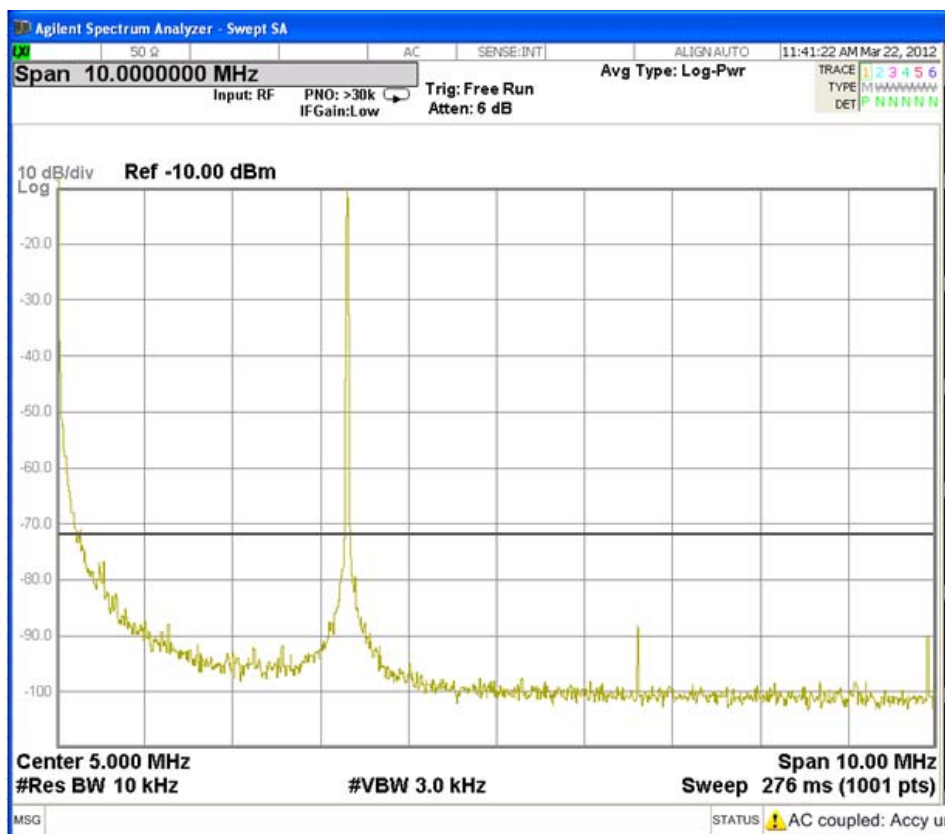

Fig. 3.5.5 Tx Frequency 3300 kHz

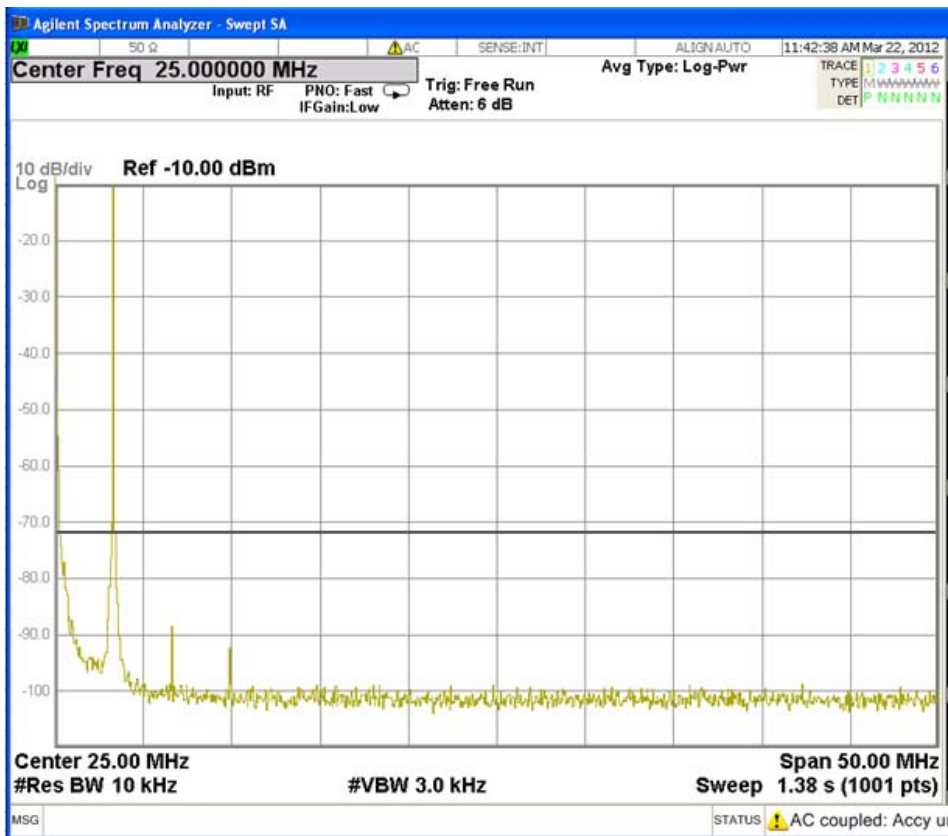

Fig. 3.5.6 Tx Frequency 3300 kHz

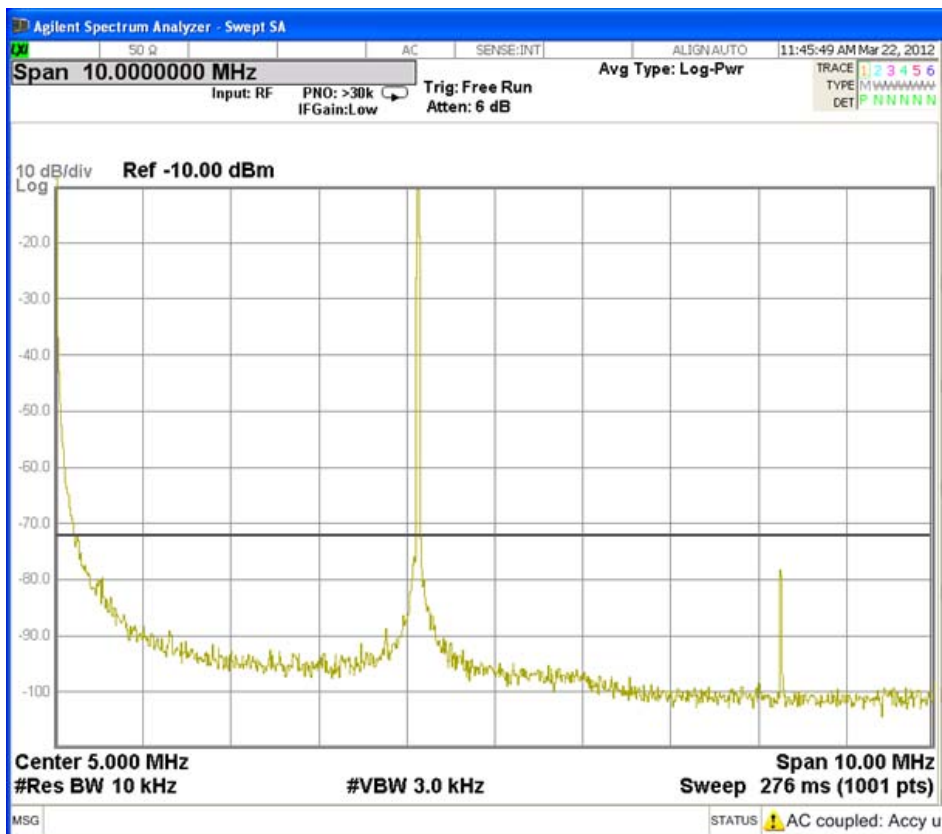
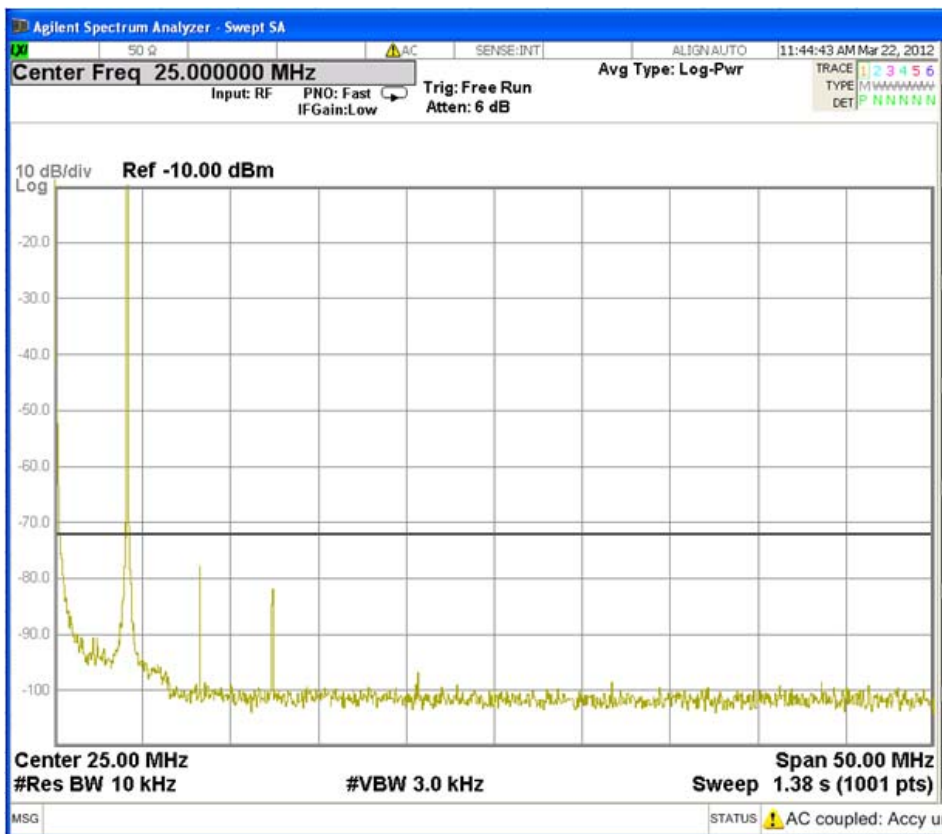
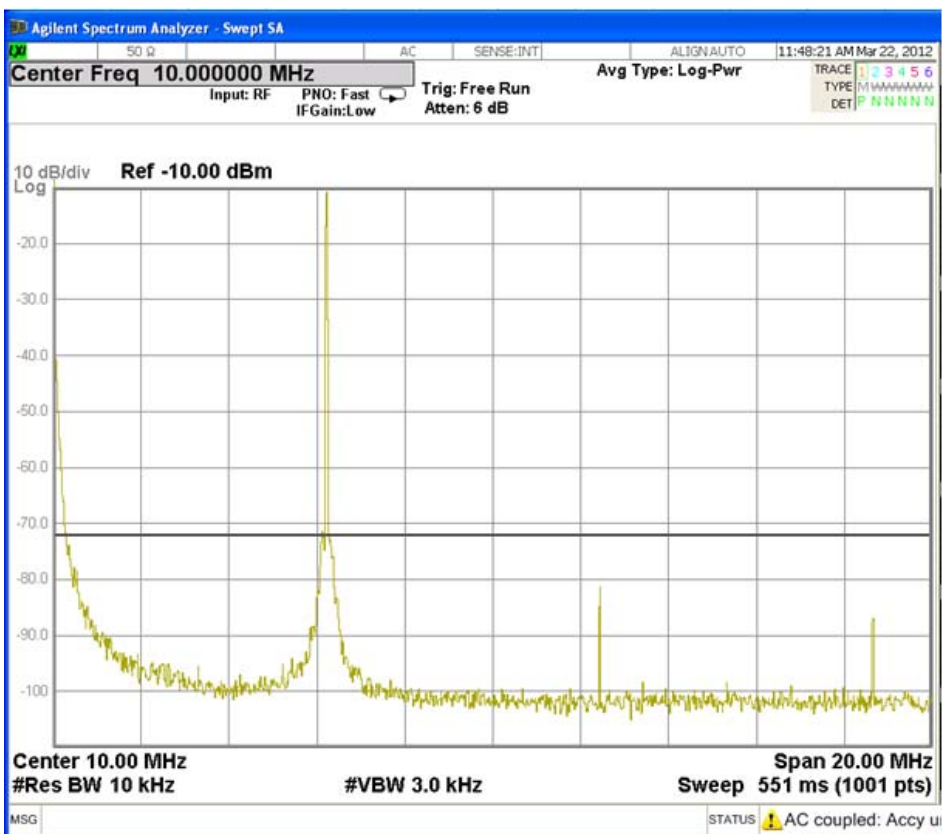

Fig. 3.5.7 Tx Frequency 4125 kHz



Limit

Fig. 3.5.8 Tx Frequency 4125 kHz



Limit

Fig. 3.5.9 Tx Frequency 6215 kHz

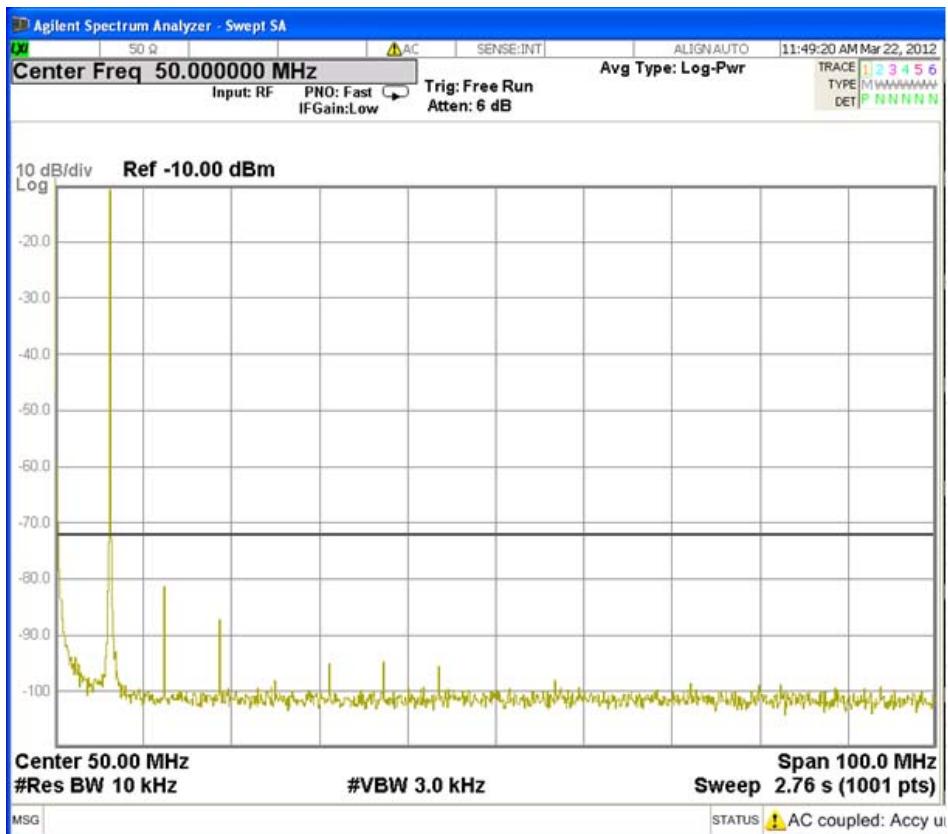

Limit

Fig. 3.5.10 Tx Frequency 6215 kHz

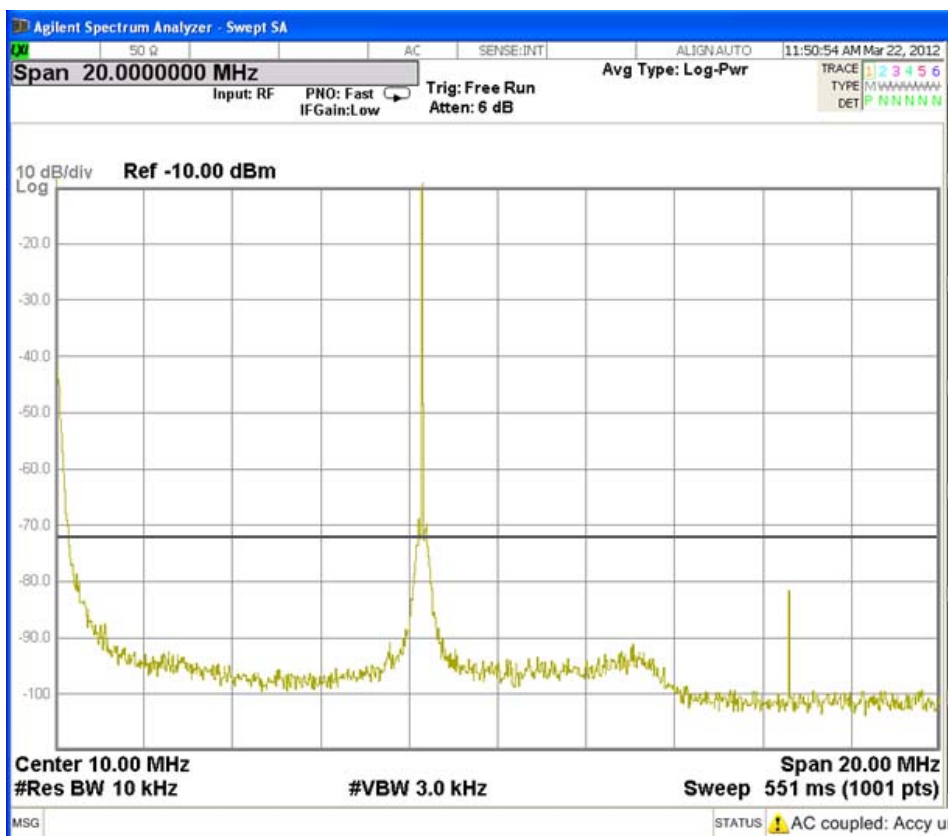

Limit

Fig. 3.5.11 Tx Frequency 8291 kHz

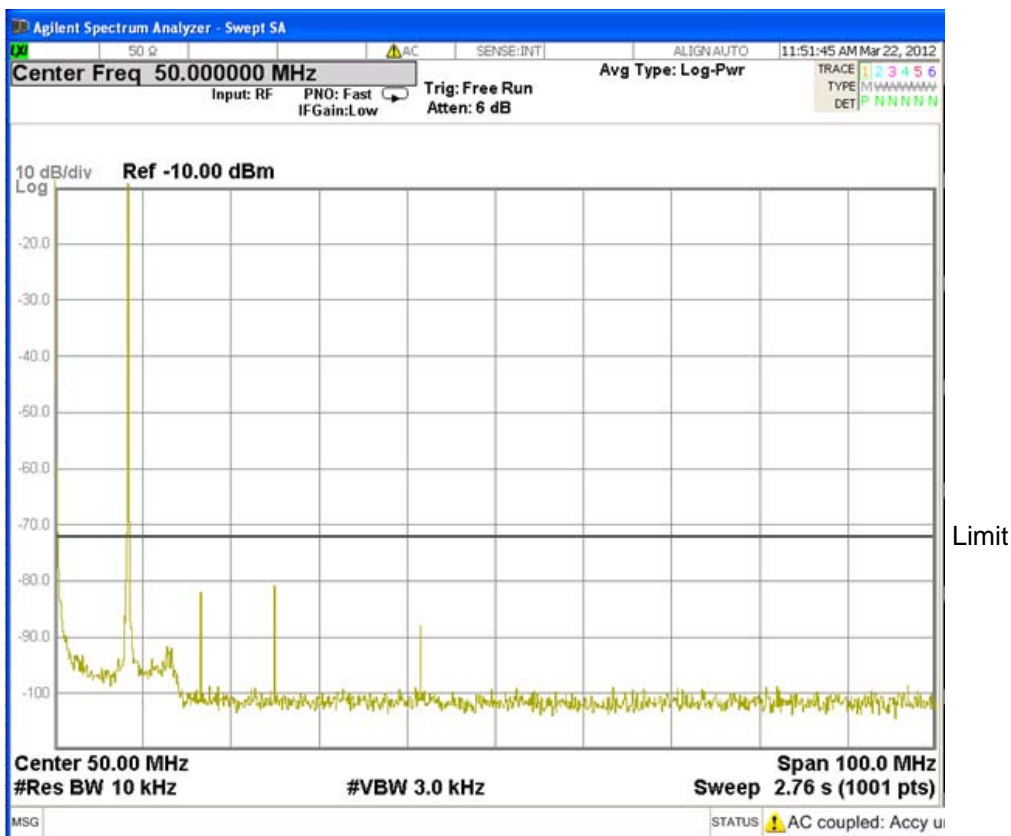

Fig. 3.5.12 Tx Frequency 8291 kHz

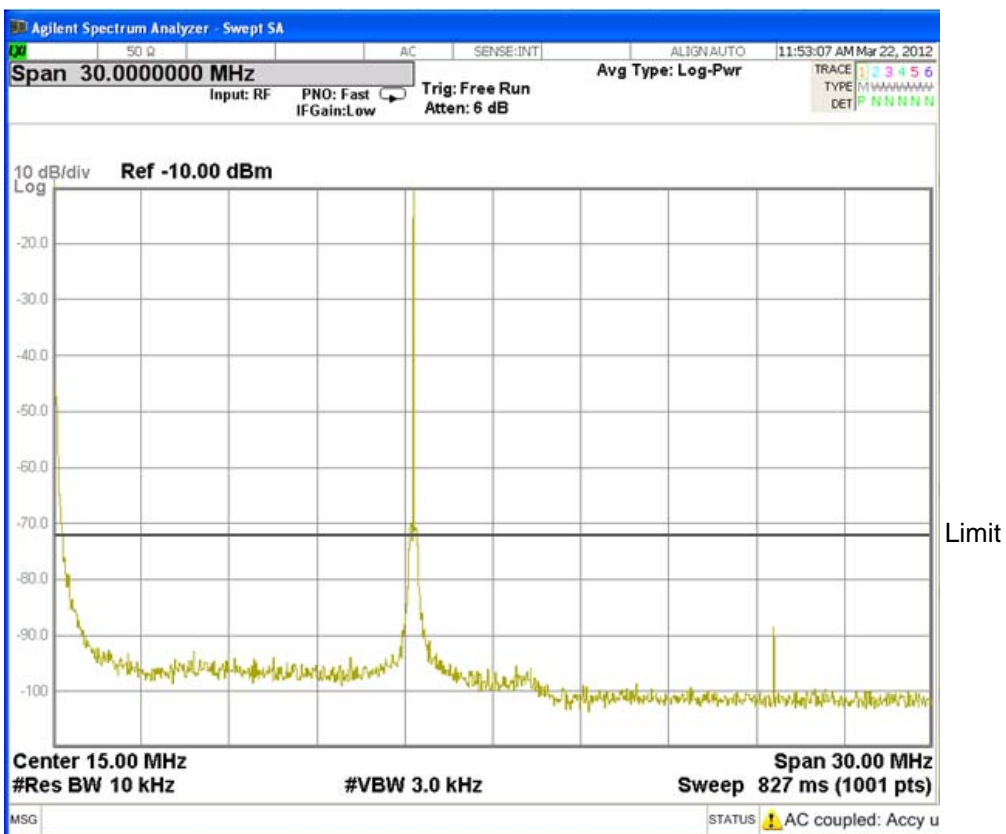
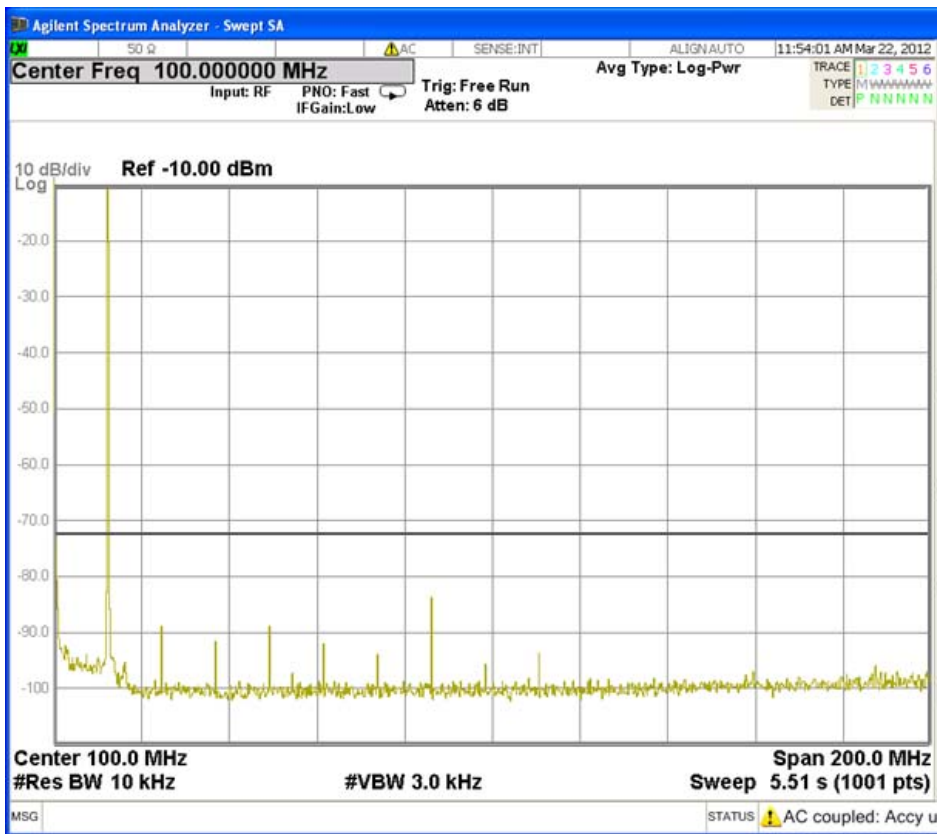
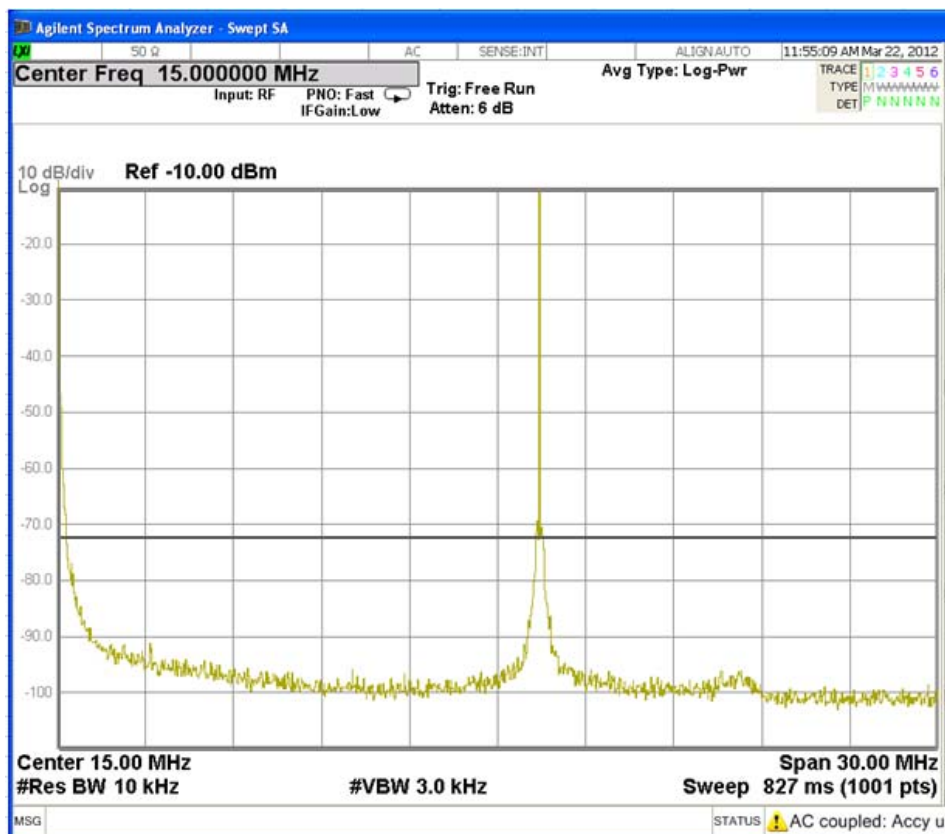

Fig. 3.5.13 Tx Frequency 12290 kHz



Limit

Fig. 3.5.14 Tx Frequency 12290 kHz



Limit

Fig. 3.5.15 Tx Frequency 16420 kHz

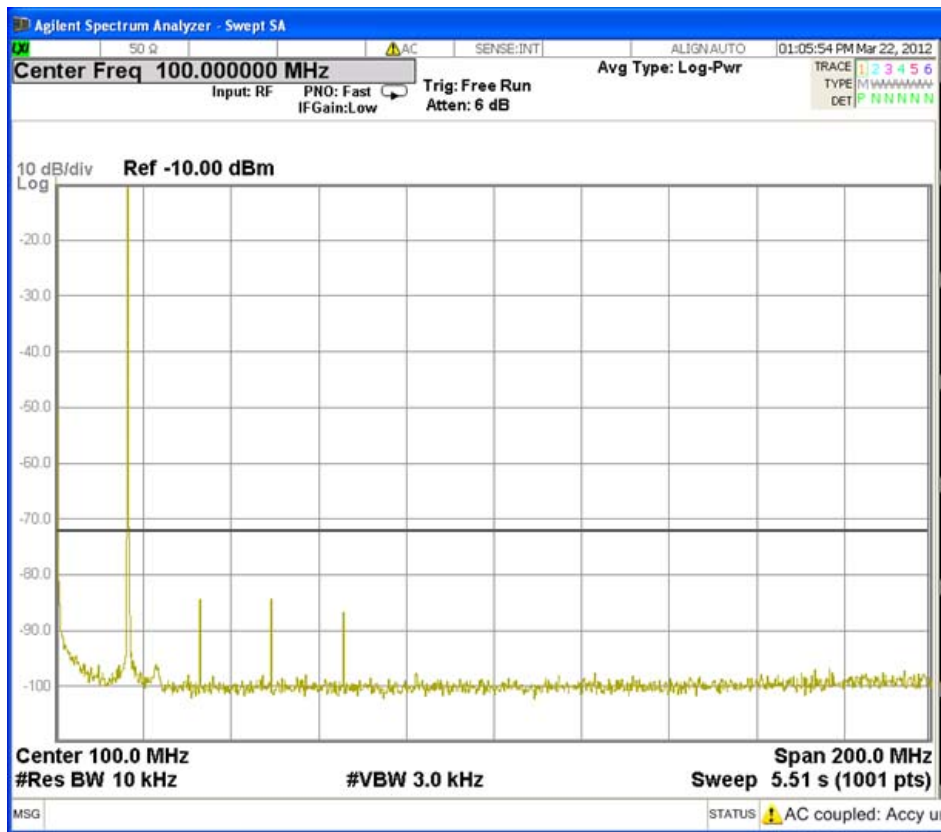

Limit

Fig. 3.5.16 Tx Frequency 16420 kHz

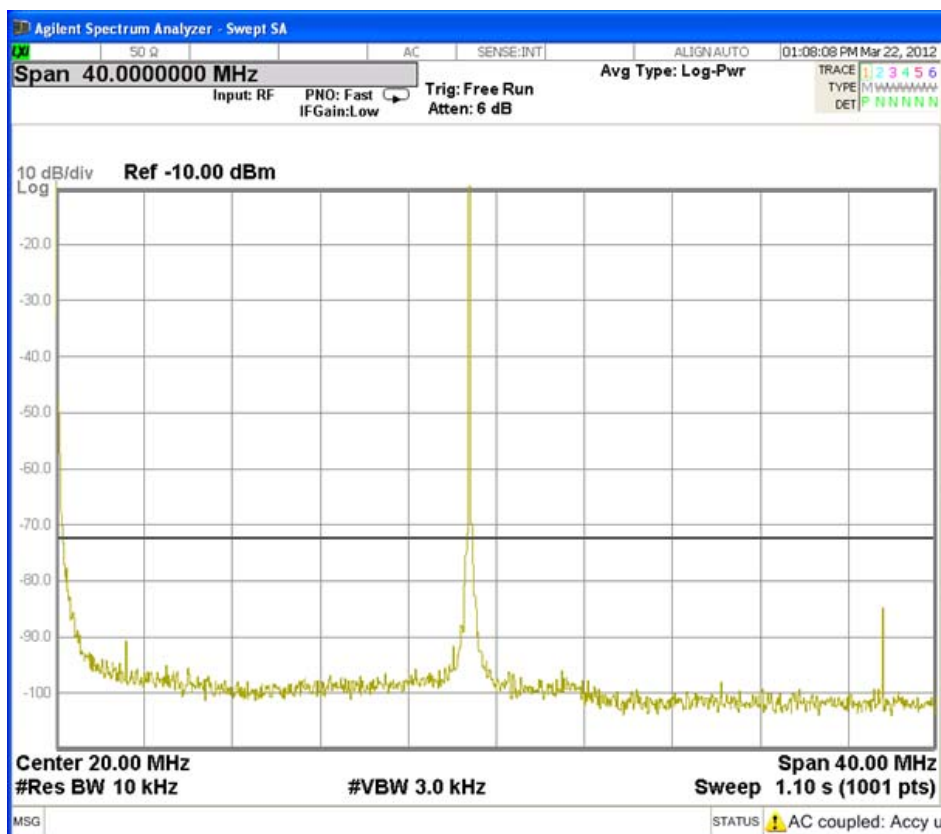

Limit

Fig. 3.5.17 Tx Frequency 18780 kHz

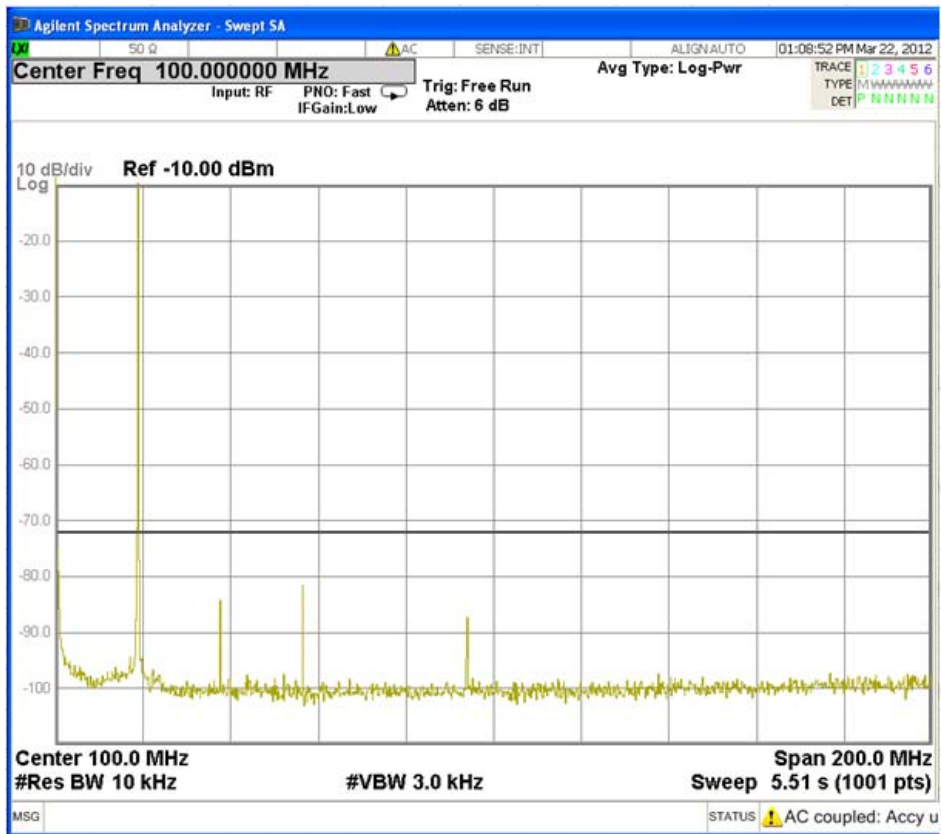

Limit

Fig. 3.5.18 Tx Frequency 18780 kHz

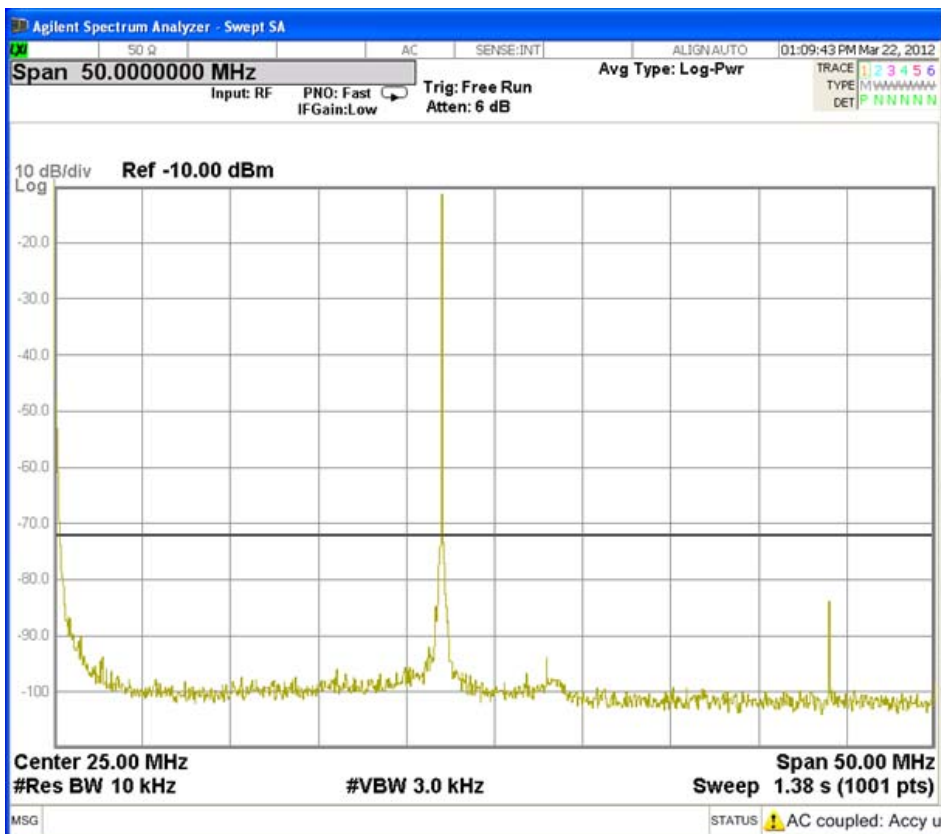

Limit

Fig. 3.5.19 Tx Frequency 22000 kHz

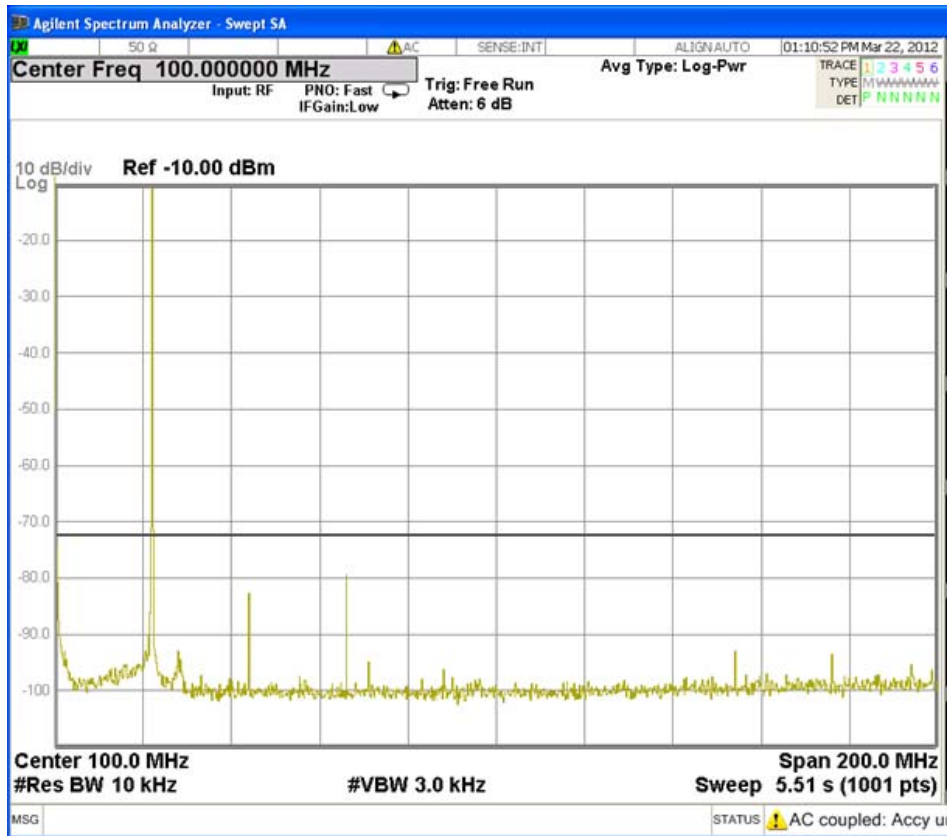

Limit

Fig. 3.5.20 Tx Frequency 22000 kHz

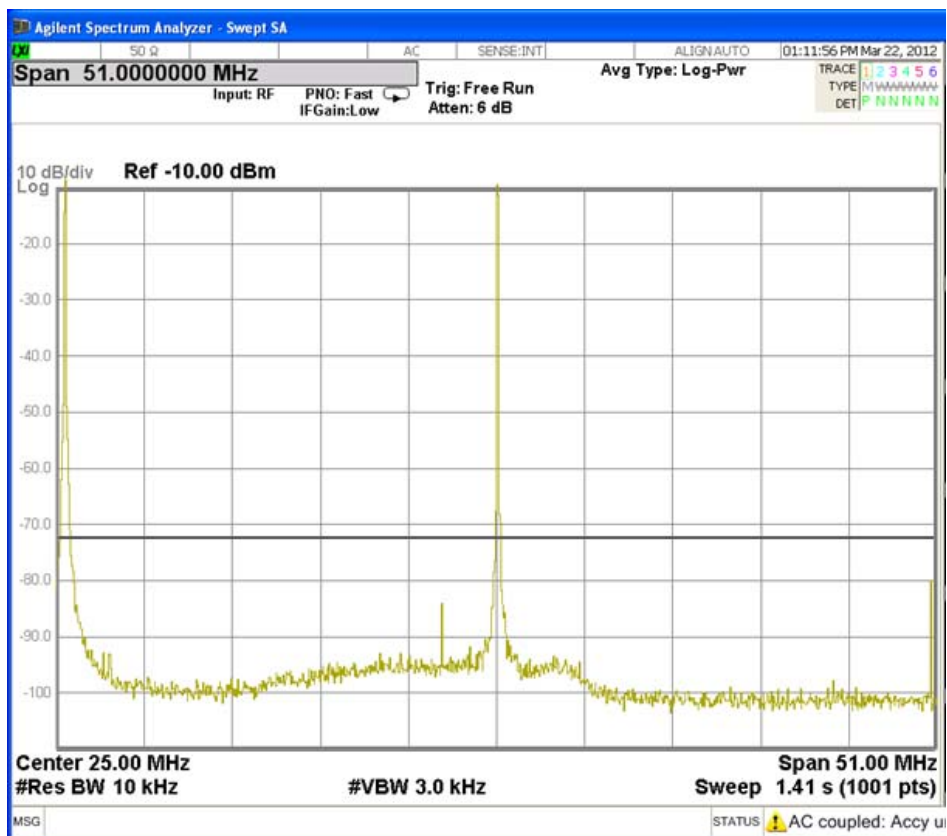

Limit

Fig. 3.5.21 Tx Frequency 25070 kHz

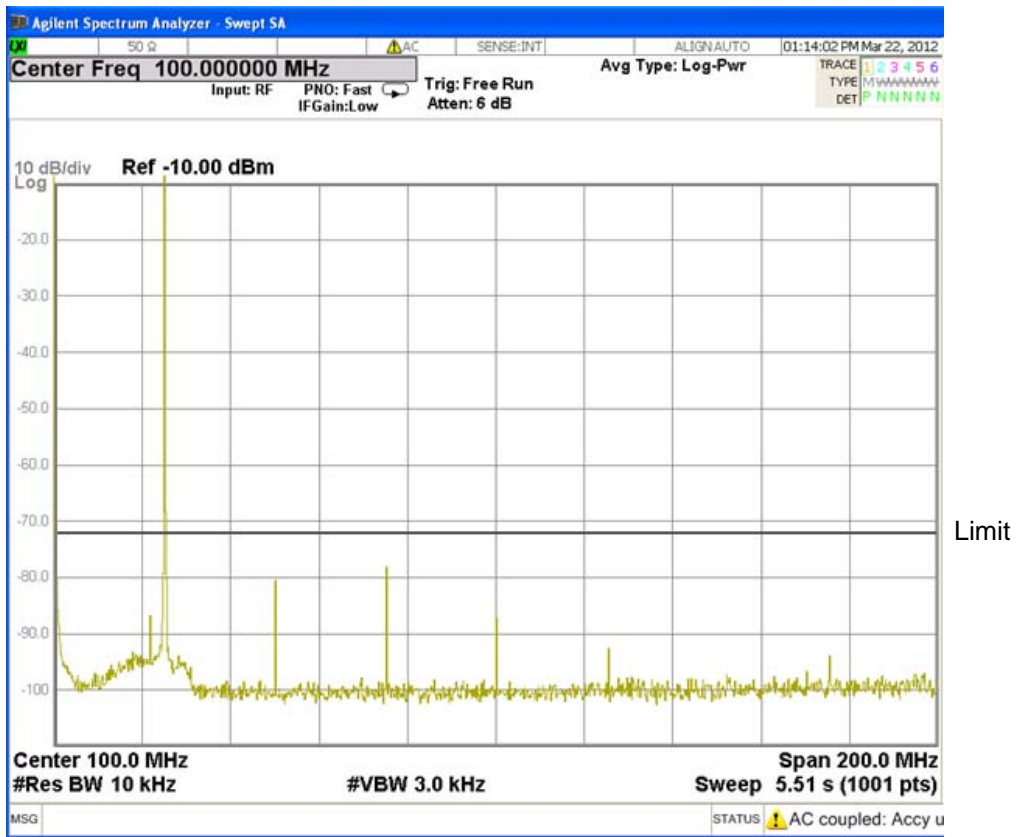

Fig. 3.5.22 Tx Frequency 25070 kHz

3.6 Field Strength of Spurious Radiation (FCC Rule Part 2.1053)

(1) Method of Measurement

The transmitter was connected with measuring equipment as in Fig. 3.6.1.

The transmitter (supplied with 24 VDC) was modulated with 2 audio tones 400 Hz and 1800 Hz in equal level. The input level was adjusted to 10 dB above the level producing PEP output of 150 W.

$$\text{Limit} = 43 + 10 \log (\text{Transmission average power}) = 43 + 10 \log (75) = 61.75 \text{ dBc}$$

The spurious radiation measurement was performed in the 3 m Anechoic Chamber and the limit values were converted into electric field strength by the substitution method.

Anechoic Chamber used for the test has been registered by FCC.
(File number: 90607)

The resolution bandwidth of the spectrum analyzer was set as follows:

Frequency range	Resolution bandwidth
9 kHz to 100 kHz	1 kHz
100 kHz to 30 MHz	10 kHz
30 MHz to 300 MHz	100 kHz

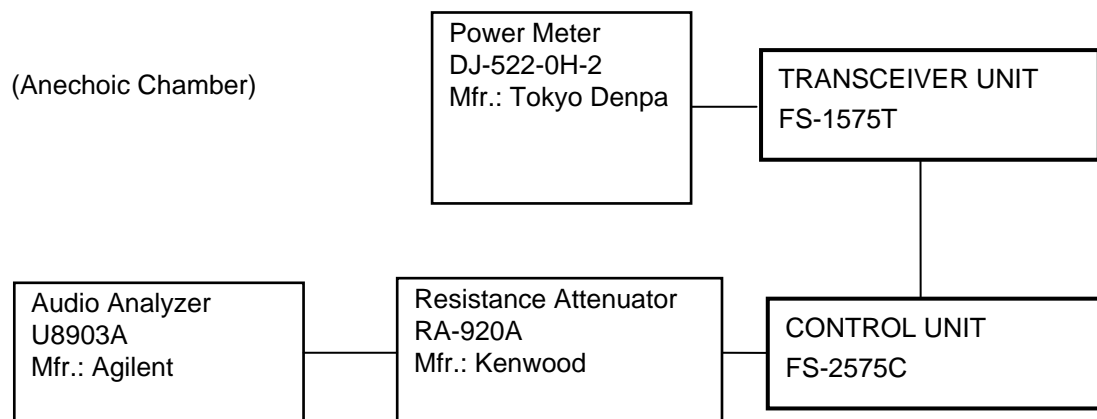

Fig. 3.6.1

Photo showing the Test Setup:

Anechoic Chamber used for the test has been registered by FCC.
(File number: 90607)



(2) Test Result

Passed.

Spurious Emissions that were prominent were listed in Table 3.6.1 to 3.6.11

Environmental conditions observed: On 26 March 2012, 21°C to 23°C, 57% to 52%RH
24.0 VDC to 24.0 VDC

Table 3.6.1 Spurious emissions of Tx-1605 kHz

Spurious frequency	Antenna Polarization	Power of spurious emission (dBc)	Limit (dBc) (*2)	Margin (dB)
2 xFc (*1)	0 degree	Not found	-62	N.A.
	90 degree	Not found	-62	N.A.
3 xFc	0 degree	-92.3	-62	30.3
	90 degree	-96.1	-62	34.1
4 xFc	0 degree	Not found	-62	N.A.
	90 degree	Not found	-62	N.A.
5 xFc	0 degree	Not found	-62	N.A.
	90 degree	Not found	-62	N.A.
6 xFc	0 degree	Not found	-62	N.A.
	90 degree	Not found	-62	N.A.
7 xFc	0 degree	Not found	-62	N.A.
	90 degree	Not found	-62	N.A.
8 xFc	0 degree	Not found	-62	N.A.
	90 degree	Not found	-62	N.A.
9 xFc	0 degree	Not found	-62	N.A.
	90 degree	Not found	-62	N.A.
10 xFc	0 degree	Not found	-62	N.A.
	90 degree	Not found	-62	N.A.
36.0 kHz (1F)	0 degree	Not found	-62	N.A.
	90 degree	Not found	-62	N.A.
72.0 kHz (2x1F)	0 degree	Not found	-62	N.A.
	90 degree	Not found	-62	N.A.
72.0 MHz (1st LO)	Horizontal	Not found	-62	N.A.
	Vertical	Not found	-62	N.A.
71.964 MHz (2nd 1F)	Horizontal	Not found	-62	N.A.
	Vertical	Not found	-62	N.A.
75.069 MHz: 71.964 MHz + Fc + 1.5 kHz (2nd LO)	Horizontal	Not found	-62	N.A.
	Vertical	Not found	-62	N.A.

(*1) Fc: Carrier frequency

(*2) Limit: $43 + 10 \log (\text{Transmission average power}) = 43 + 10 \log (75) = 61.75 \text{ dBc} \approx 62 \text{ dBc}$

Note: N.A.- Not applicable.

Table 3.6.2 Spurious emissions of Tx-2182 kHz

Spurious frequency	Antenna Polarization	Power of spurious emission (dBc)	Limit (dBc) (*2)	Margin (dB)
2 xFc (*1)	0 degree	-91.1	-62	29.1
	90 degree	-93.9	-62	31.9
3 xFc	0 degree	-94.3	-62	32.3
	90 degree	-97.7	-62	35.7
4 xFc	0 degree	Not found	-62	N.A.
	90 degree	Not found	-62	N.A.
5 xFc	0 degree	Not found	-62	N.A.
	90 degree	Not found	-62	N.A.
6 xFc	0 degree	Not found	-62	N.A.
	90 degree	Not found	-62	N.A.
7 xFc	0 degree	Not found	-62	N.A.
	90 degree	Not found	-62	N.A.
8 xFc	0 degree	Not found	-62	N.A.
	90 degree	Not found	-62	N.A.
9 xFc	0 degree	Not found	-62	N.A.
	90 degree	Not found	-62	N.A.
10 xFc	0 degree	Not found	-62	N.A.
	90 degree	Not found	-62	N.A.
36.0 kHz (1F)	0 degree	Not found	-62	N.A.
	90 degree	Not found	-62	N.A.
72.0 kHz (2 x1F)	0 degree	Not found	-62	N.A.
	90 degree	Not found	-62	N.A.
72.0 MHz (1st LO)	Horizontal	Not found	-62	N.A.
	Vertical	Not found	-62	N.A.
71.964 MHz (2nd 1F)	Horizontal	Not found	-62	N.A.
	Vertical	Not found	-62	N.A.
75.646 MHz: 71.964 MHz + Fc + 1.5 kHz (2nd LO)	Horizontal	Not found	-62	N.A.
	Vertical	Not found	-62	N.A.

(*1) Fc: Carrier frequency

(*2) Limit: $43 + 10 \log(\text{Transmission average power}) = 43 + 10 \log(75) = 61.75 \text{ dBc} \approx 62 \text{ dBc}$

Note: N.A.- Not applicable.

Table 3.6.3 Spurious emissions of Tx-3300 kHz

Spurious frequency	Antenna Polarization	Power of spurious emission (dBc)	Limit (dBc) (*2)	Margin (dB)
2 xFc (*1)	0 degree	Not found	-62	N.A.
	90 degree	Not found	-62	N.A.
3 xFc	0 degree	-96.1	-62	34.1
	90 degree	Not found	-62	N.A.
4 xFc	0 degree	Not found	-62	N.A.
	90 degree	Not found	-62	N.A.
5 xFc	0 degree	Not found	-62	N.A.
	90 degree	Not found	-62	N.A.
6 xFc	0 degree	Not found	-62	N.A.
	90 degree	Not found	-62	N.A.
7 xFc	0 degree	-96.0	-62	34.0
	90 degree	-90.0	-62	28.0
8 xFc	0 degree	Not found	-62	N.A.
	90 degree	Not found	-62	N.A.
9 xFc	0 degree	Not found	-62	N.A.
	90 degree	Not found	-62	N.A.
10 xFc	Horizontal	Not found	-62	N.A.
	Vertical	-116.6	-62	54.6
36.0 kHz (1F)	0 degree	Not found	-62	N.A.
	90 degree	Not found	-62	N.A.
72.0 kHz (2 x1F)	0 degree	Not found	-62	N.A.
	90 degree	Not found	-62	N.A.
72.0 MHz (1st LO)	Horizontal	Not found	-62	N.A.
	Vertical	Not found	-62	N.A.
71.964 MHz (2nd 1F)	Horizontal	Not found	-62	N.A.
	Vertical	Not found	-62	N.A.
76.487 MHz:	Horizontal	Not found	-62	N.A.
71.964 MHz + Fc + 1.5 kHz (2nd LO)	Vertical	Not found	-62	N.A.

(*1) Fc: Carrier frequency

(*2) Limit: $43 + 10 \log(\text{Transmission average power}) = 43 + 10 \log(75) = 61.75 \text{ dBc} \approx 62 \text{ dBc}$

Note: N.A.- Not applicable.

Table 3.6.4 Spurious emissions of Tx-4065 kHz

Spurious frequency	Antenna Polarization	Power of spurious emission (dBc)	Limit (dBc) (*2)	Margin (dB)
2 xFc (*1)	0 degree	Not found	-62	N.A.
	90 degree	-99.2	-62	37.2
3 xFc	0 degree	-97.5	-62	35.5
	90 degree	-97.2	-62	35.2
4 xFc	0 degree	Not found	-62	N.A.
	90 degree	Not found	-62	N.A.
5 xFc	0 degree	Not found	-62	N.A.
	90 degree	-92.3	-62	30.3
6 xFc	0 degree	Not found	-62	N.A.
	90 degree	-94.2	-62	32.2
7 xFc	0 degree	Not found	-62	N.A.
	90 degree	-95.8	-62	33.8
8 xFc	Horizontal	Not found	-62	N.A.
	Vertical	-115.3	-62	53.3
9 xFc	Horizontal	-116.5	-62	54.5
	Vertical	-103.8	-62	41.8
10 xFc	Horizontal	-117.0	-62	55.0
	Vertical	-111.3	-62	49.3
36.0 kHz (1F)	0 degree	Not found	-62	N.A.
	90 degree	Not found	-62	N.A.
72.0 kHz (2 x1F)	0 degree	Not found	-62	N.A.
	90 degree	Not found	-62	N.A.
72.0 MHz (1st LO)	Horizontal	Not found	-62	N.A.
	Vertical	Not found	-62	N.A.
71.964 MHz (2nd 1F)	Horizontal	Not found	-62	N.A.
	Vertical	Not found	-62	N.A.
77.529 MHz:	Horizontal	Not found	-62	N.A.
71.964 MHz + Fc + 1.5 kHz (2nd LO)	Vertical	Not found	-62	N.A.

(*1) Fc: Carrier frequency

(*2) Limit: $43 + 10 \log(\text{Transmission average power}) = 43 + 10 \log(75) = 61.75 \text{ dBc} \approx 62 \text{ dBc}$

Note: N.A.- Not applicable.

Table 3.6.5 Spurious emissions of Tx-6200 kHz

Spurious frequency	Antenna Polarization	Power of spurious emission (dBc)	Limit (dBc) (*2)	Margin (dB)
2 xFc (*1)	0 degree	Not found	-62	N.A.
	90 degree	Not found	-62	N.A.
3 xFc	0 degree	-91.5	-62	29.5
	90 degree	-83.5	-62	21.5
4 xFc	0 degree	Not found	-62	N.A.
	90 degree	-94.3	-62	32.3
5 xFc	Horizontal	-104.3	-62	42.3
	Vertical	-93.5	-62	31.5
6 xFc	Horizontal	Not found	-62	N.A.
	Vertical	-104.9	-62	42.9
7 xFc	Horizontal	Not found	-62	N.A.
	Vertical	-107.5	-62	45.5
8 xFc	Horizontal	Not found	-62	N.A.
	Vertical	Not found	-62	N.A.
9 xFc	Horizontal	Not found	-62	N.A.
	Vertical	Not found	-62	N.A.
10 xFc	Horizontal	Not found	-62	N.A.
	Vertical	Not found	-62	N.A.
36.0 kHz (1F)	0 degree	Not found	-62	N.A.
	90 degree	Not found	-62	N.A.
72.0 kHz (2 x1F)	0 degree	Not found	-62	N.A.
	90 degree	Not found	-62	N.A.
72.0 MHz (1st LO)	Horizontal	Not found	-62	N.A.
	Vertical	Not found	-62	N.A.
71.964 MHz (2nd 1F)	Horizontal	Not found	-62	N.A.
	Vertical	Not found	-62	N.A.
79.664 MHz:	Horizontal	Not found	-62	N.A.
71.964 MHz + Fc + 1.5 kHz (2nd LO)	Vertical	-110.9	-62	48.9

(*1) Fc: Carrier frequency

(*2) Limit: $43 + 10 \log(\text{Transmission average power}) = 43 + 10 \log(75) = 61.75 \text{ dBc} \approx 62 \text{ dBc}$

Note: N.A.- Not applicable.

Table 3.6.6 Spurious emissions of Tx-8195 kHz

Spurious frequency	Antenna Polarization	Power of spurious emission (dBc)	Limit (dBc) (*2)	Margin (dB)
2 xFc (*1)	0 degree	Not found	-62	N.A.
	90 degree	Not found	-62	N.A.
3 xFc	0 degree	-87.3	-62	25.3
	90 degree	-76.2	-62	14.2
4 xFc	Horizontal	-111.1	-62	49.1
	Vertical	-105.6	-62	43.6
5 xFc	Horizontal	-100.9	-62	38.9
	Vertical	-97.1	-62	35.1
6 xFc	Horizontal	-122.0	-62	60.0
	Vertical	-114.0	-62	52.0
7 xFc	Horizontal	-124.1	-62	62.1
	Vertical	-118.2	-62	56.2
8 xFc	Horizontal	Not found	-62	N.A.
	Vertical	Not found	-62	N.A.
9 xFc	Horizontal	-105.4	-62	43.4
	Vertical	-105.3	-62	43.3
10 xFc	Horizontal	-114.2	-62	52.2
	Vertical	Not found	-62	N.A.
36.0 kHz (IF)	0 degree	Not found	-62	N.A.
	90 degree	Not found	-62	N.A.
72.0 kHz (2 xIF)	0 degree	Not found	-62	N.A.
	90 degree	Not found	-62	N.A.
72.0 MHz (1st LO)	Horizontal	Not found	-62	N.A.
	Vertical	Not found	-62	N.A.
71.964 MHz (2nd IF)	Horizontal	Not found	-62	N.A.
	Vertical	Not found	-62	N.A.
81.659 MHz:	Horizontal	-114.2	-62	52.2
71.964 MHz + Fc + 1.5 kHz (2nd LO)	Vertical	Not found	-62	N.A.

(*1) Fc: Carrier frequency

(*2) Limit: $43 + 10 \log(\text{Transmission average power}) = 43 + 10 \log(75) = 61.75 \text{ dBc} \approx 62 \text{ dBc}$

Note: N.A.- Not applicable.

Table 3.6.7 Spurious emissions of Tx-12230 kHz

Spurious frequency	Antenna Polarization	Power of spurious emission (dBc)	Limit (dBc) (*2)	Margin (dB)
2 xFc (*1)	0 degree	-90.1	-62	28.1
	90 degree	-78.5	-62	16.5
3 xFc	Horizontal	-102.1	-62	40.1
	Vertical	-85.2	-62	23.2
4 xFc	Horizontal	-115.1	-62	53.1
	Vertical	-105.7	-62	43.7
5 xFc	Horizontal	-106.9	-62	44.9
	Vertical	-104.4	-62	42.4
6 xFc	Horizontal	-113.1	-62	51.1
	Vertical	-113.8	-62	51.8
7 xFc	Horizontal	-91.8	-62	29.8
	Vertical	-92.6	-62	30.6
8 xFc	Horizontal	-111.6	-62	49.6
	Vertical	-109.6	-62	47.6
9 xFc	Horizontal	-92.2	-62	30.2
	Vertical	-93.0	-62	31.0
10 xFc	Horizontal	Not found	-62	N.A.
	Vertical	Not found	-62	N.A.
36.0 kHz (IF)	0 degree	Not found	-62	N.A.
	90 degree	Not found	-62	N.A.
72.0 kHz (2 xIF)	0 degree	Not found	-62	N.A.
	90 degree	Not found	-62	N.A.
72.0 MHz (1st LO)	Horizontal	Not found	-62	N.A.
	Vertical	Not found	-62	N.A.
71.964 MHz (2nd IF)	Horizontal	Not found	-62	N.A.
	Vertical	Not found	-62	N.A.
85.694 MHz: 71.964 MHz + Fc + 1.5 kHz (2nd LO)	Horizontal	Not found	-62	N.A.
	Vertical	Not found	-62	N.A.

(*1) Fc: Carrier frequency

(*2) Limit: $43 + 10 \log(\text{Transmission average power}) = 43 + 10 \log(75) = 61.75 \text{ dBc} \approx 62 \text{ dBc}$

Note: N.A.- Not applicable.

Table 3.6.8 Spurious emissions of Tx-16360 kHz

Spurious frequency	Antenna Polarization	Power of spurious emission (dBc)	Limit (dBc) (*2)	Margin (dB)
2 xFc (*1)	Horizontal	-108.3	-62	46.3
	Vertical	-105.4	-62	43.4
3 xFc	Horizontal	-93.1	-62	31.1
	Vertical	-85.2	-62	23.2
4 xFc	Horizontal	-121.4	-62	59.4
	Vertical	-105.4	-62	43.4
5 xFc	Horizontal	-96.4	-62	34.4
	Vertical	-99.7	-62	37.7
6 xFc	Horizontal	-112.5	-62	50.5
	Vertical	-108.4	-62	46.4
7 xFc	Horizontal	-107.5	-62	45.5
	Vertical	-105.1	-62	43.1
8 xFc	Horizontal	-118.9	-62	56.9
	Vertical	Not found	-62	N.A.
9 xFc	Horizontal	-109.0	-62	47.0
	Vertical	-109.5	-62	47.5
10 xFc	Horizontal	-112.8	-62	50.8
	Vertical	-113.0	-62	51.0
36.0 kHz (IF)	0 degree	Not found	-62	N.A.
	90 degree	Not found	-62	N.A.
72.0 kHz (2 xIF)	0 degree	Not found	-62	N.A.
	90 degree	Not found	-62	N.A.
72.0 MHz (1st LO)	Horizontal	Not found	-62	N.A.
	Vertical	Not found	-62	N.A.
71.964 MHz (2nd IF)	Horizontal	Not found	-62	N.A.
	Vertical	Not found	-62	N.A.
89.824 MHz: 71.964 MHz + Fc + 1.5 kHz (2nd LO)	Horizontal	Not found	-62	N.A.
	Vertical	Not found	-62	N.A.

(*1) Fc: Carrier frequency

(*2) Limit: $43 + 10 \log(\text{Transmission average power}) = 43 + 10 \log(75) = 61.75 \text{ dBc} \approx 62 \text{ dBc}$

Note: N.A.- Not applicable.

Table 3.6.9 Spurious emissions of Tx-18780 kHz

Spurious frequency	Antenna Polarization	Power of spurious emission (dBc)	Limit (dBc) (*2)	Margin (dB)
2 xFc (*1)	Horizontal	-113.5	-62	51.5
	Vertical	-99.5	-62	37.5
3 xFc	Horizontal	-110.0	-62	48.0
	Vertical	-98.9	-62	36.9
4 xFc	Horizontal	-110.8	-62	48.8
	Vertical	-114.1	-62	52.1
5 xFc	Horizontal	-84.7	-62	22.7
	Vertical	-84.4	-62	22.4
6 xFc	Horizontal	-111.8	-62	49.8
	Vertical	-109.1	-62	47.1
7 xFc	Horizontal	-101.9	-62	39.9
	Vertical	-105.1	-62	43.1
8 xFc	Horizontal	Not found	-62	N.A.
	Vertical	Not found	-62	N.A.
9 xFc	Horizontal	-102.5	-62	40.5
	Vertical	-101.5	-62	39.5
10 xFc	Horizontal	-106.0	-62	44.0
	Vertical	-102.8	-62	40.8
36.0 kHz (IF)	0 degree	Not found	-62	N.A.
	90 degree	Not found	-62	N.A.
72.0 kHz (2 xIF)	0 degree	Not found	-62	N.A.
	90 degree	Not found	-62	N.A.
72.0 MHz (1st LO)	Horizontal	Not found	-62	N.A.
	Vertical	Not found	-62	N.A.
71.964 MHz (2nd IF)	Horizontal	Not found	-62	N.A.
	Vertical	Not found	-62	N.A.
92.244 MHz: 71.964 MHz + Fc + 1.5 kHz (2nd LO)	Horizontal	Not found	-62	N.A.
	Vertical	Not found	-62	N.A.

(*1) Fc: Carrier frequency

(*2) Limit: $43 + 10 \log (\text{Transmission average power}) = 43 + 10 \log (75) = 61.75 \text{ dBc} \approx 62 \text{ dBc}$

Note: N.A.- Not applicable.

Table 3.6.10 Spurious emissions of Tx-22000 kHz

Spurious frequency	Antenna Polarization	Power of spurious emission (dBc)	Limit (dBc) (*2)	Margin (dB)
2 xFc (*1)	Horizontal	-114.2	-62	52.2
	Vertical	-104.5	-62	42.5
3 xFc	Horizontal	-109.4	-62	47.4
	Vertical	-103.1	-62	41.1
4 xFc	Horizontal	-105.4	-62	43.4
	Vertical	-96.6	-62	34.6
5 xFc	Horizontal	-84.8	-62	22.8
	Vertical	-84.8	-62	22.8
6 xFc	Horizontal	-111.8	-62	49.8
	Vertical	Not found	-62	N.A.
7 xFc	Horizontal	-108.1	-62	46.1
	Vertical	-105.5	-62	43.5
8 xFc	Horizontal	-105.3	-62	43.3
	Vertical	-105.2	-62	43.2
9 xFc	Horizontal	-91.8	-62	29.8
	Vertical	-93.0	-62	31.0
10 xFc	Horizontal	-93.4	-62	31.4
	Vertical	-92.0	-62	30.0
36.0 kHz (IF)	0 degree	Not found	-62	N.A.
	90 degree	Not found	-62	N.A.
72.0 kHz (2 xIF)	0 degree	Not found	-62	N.A.
	90 degree	Not found	-62	N.A.
72.0 MHz (1st LO)	Horizontal	Not found	-62	N.A.
	Vertical	Not found	-62	N.A.
71.964 MHz (2nd IF)	Horizontal	Not found	-62	N.A.
	Vertical	Not found	-62	N.A.
95.464 MHz:	Horizontal	Not found	-62	N.A.
71.964 MHz + Fc + 1.5 kHz (2nd LO)	Vertical	Not found	-62	N.A.

(*1) Fc: Carrier frequency

(*2) Limit: $43 + 10 \log (\text{Transmission average power}) = 43 + 10 \log (75) = 61.75 \text{ dBc} \approx 62 \text{ dBc}$

Note: N.A.- Not applicable.

Table 3.6.11 Spurious emissions of Tx-25070 kHz

Spurious frequency	Antenna Polarization	Power of spurious emission (dBc)	Limit (dBc) (*2)	Margin (dB)
2 xFc (*1)	Horizontal	-109.8	-62	47.8
	Vertical	-102.8	-62	40.8
3 xFc	Horizontal	-88.6	-62	26.6
	Vertical	-88.2	-62	26.2
4 xFc	Horizontal	-103.9	-62	41.9
	Vertical	-100.4	-62	38.4
5 xFc	Horizontal	-99.0	-62	37.0
	Vertical	-101.2	-62	39.2
6 xFc	Horizontal	-107.6	-62	45.6
	Vertical	-104.9	-62	42.9
7 xFc	Horizontal	-97.9	-62	35.9
	Vertical	-94.9	-62	32.9
8 xFc	Horizontal	-89.2	-62	27.2
	Vertical	-92.2	-62	30.2
9 xFc	Horizontal	-96.0	-62	34.0
	Vertical	-99.2	-62	37.2
10 xFc	Horizontal	-92.2	-62	30.2
	Vertical	-92.0	-62	30.0
36.0 kHz (IF)	0 degree	Not found	-62	N.A.
	90 degree	Not found	-62	N.A.
72.0 kHz (2 xIF)	0 degree	Not found	-62	N.A.
	90 degree	Not found	-62	N.A.
72.0 MHz (1st LO)	Horizontal	Not found	-62	N.A.
	Vertical	Not found	-62	N.A.
71.964 MHz (2nd IF)	Horizontal	Not found	-62	N.A.
	Vertical	Not found	-62	N.A.
98.534 MHz:	Horizontal	Not found	-62	N.A.
71.964 MHz + Fc + 1.5 kHz (2nd LO)	Vertical	Not found	-62	N.A.

(*1) Fc: Carrier frequency

(*2) Limit: $43 + 10 \log (\text{Transmission average power}) = 43 + 10 \log (75) = 61.75 \text{ dBc} \approx 62 \text{ dBc}$

Note: N.A.- Not applicable.

3.7 Frequency Stability (FCC Rule Part 2.1055 & 80.209)

(1) Method of Measurement

The FS-1575 stored in the chamber, was connected with measuring equipment as in Fig.3.7.1

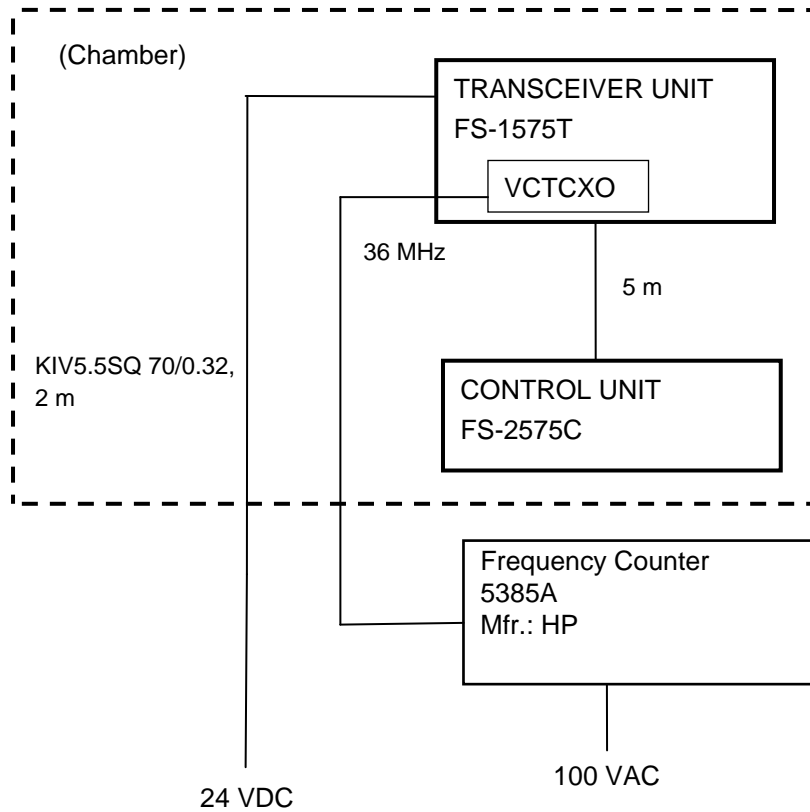

Fig. 3.7.1

Limit:

± 13 Hz (± 0.36 ppm^(*) for VCTCXO Freq.)

VCTCXO Freq.= 36 MHz

(*): Highest TX frequency: 27.5 MHz,

Frequency error limit: 10 Hz (according to FCC Rule Part 80.209)

So, $10 \text{ (Hz)} / 27.5 \text{ (MHz)} = 0.36 \text{ ppm}$

With the power switch off, the FS-1575 was left in the chamber until thermal equilibrium was achieved. Power was then applied and, after 10 minutes of warm-up, the reference oscillator frequency was measured. Measurements were made within the temperature range -20 °C to + 50 °C at 10 °C interval, by applying 85 % (20.4 VDC), 100% (24.0 VDC), and 115% (27.6 VDC) of the rated DC supply voltage.

Frequency stability measurements were also performed in cold start conditions (no warm-up period). For the purpose of these measurements, change in the reference oscillator frequency was plotted in the function of the lapse of time up to 20 minutes. The FS-1575 was tested at -20 °C, 0 °C and + 30 °C.

Photo showing the Test Setup:

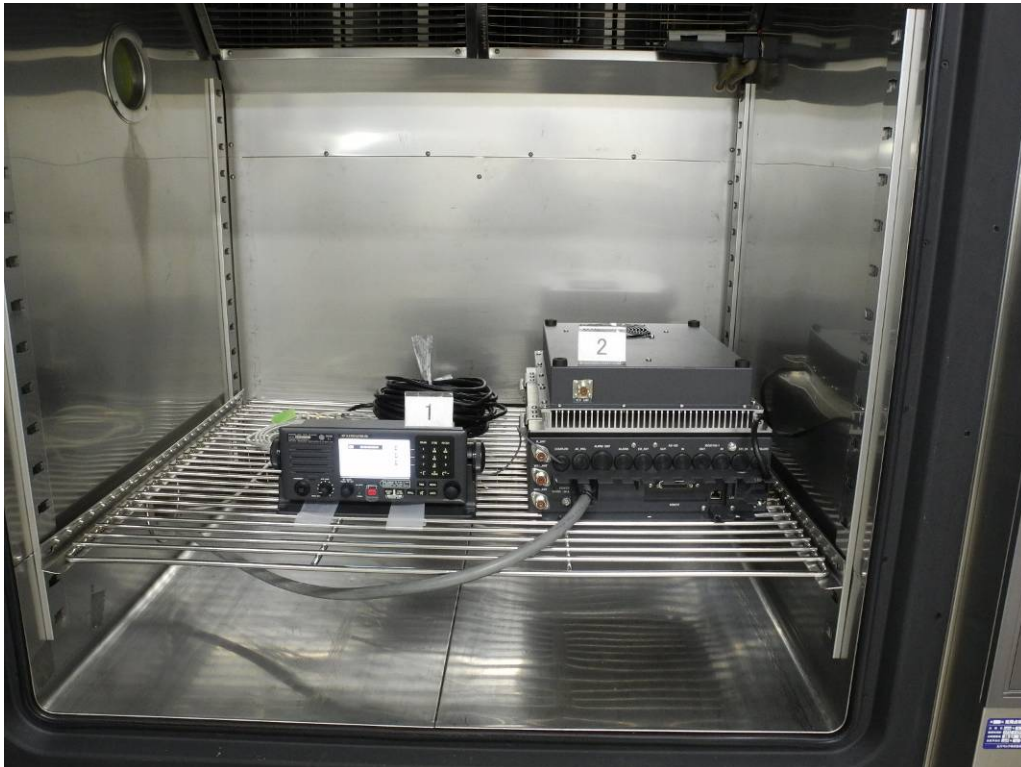

(2) Test Result

Passed.

See following table and the figures.

Table 3.7.1

Temperature (°C)	Voltage conditions					
	20.4 VDC (-15%)		24.0 VDC (norm.)		27.6 VDC (+15%)	
	VCTCXO Freq. (Hz)	Freq. Error (Hz)	VCTCXO Freq. (Hz)	Freq. Error (Hz)	VCTCXO Freq. (Hz)	Freq. Error (Hz)
-20	35,999,997	-3	35,999,997	-3	35,999,997	-3
-10	35,999,999	-1	35,999,999	-1	35,999,999	-1
0	36,000,002	2	36,000,002	2	36,000,002	2
10	36,000,000	0	36,000,000	0	36,000,000	0
20	36,000,000	0	36,000,000	0	36,000,000	0
30	36,000,002	2	36,000,002	2	36,000,002	2
40	36,000,002	2	36,000,002	2	36,000,002	2
50	36,000,002	2	36,000,002	2	36,000,002	2

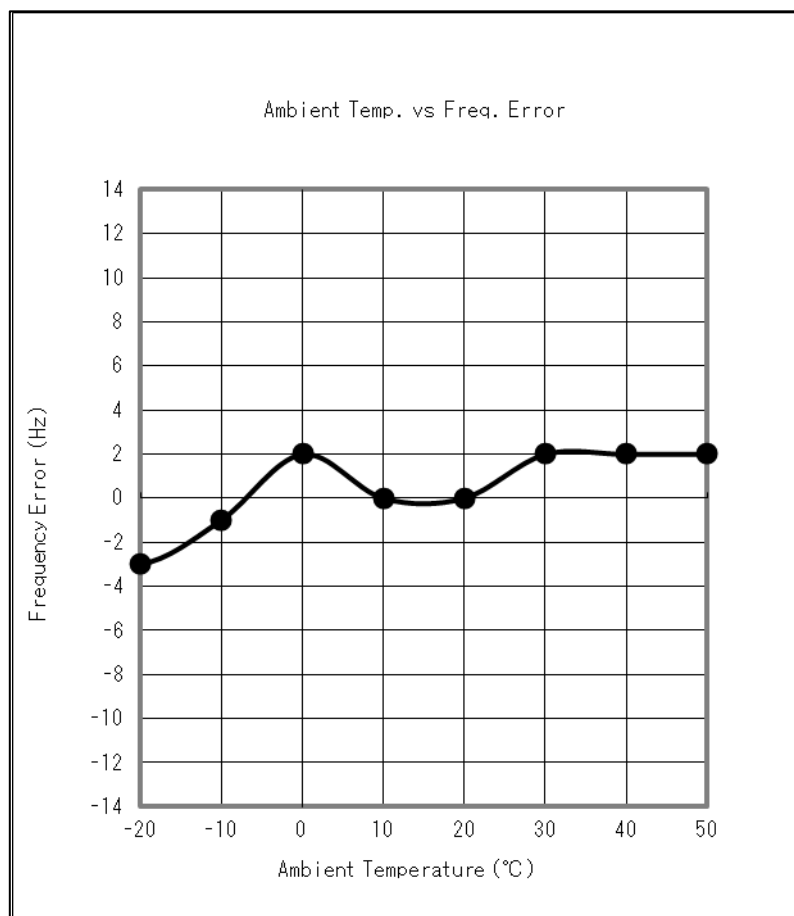

Fig. 3.7.2

Frequency stability (Cold start (-20°C))
Supply voltage: 24 VDC

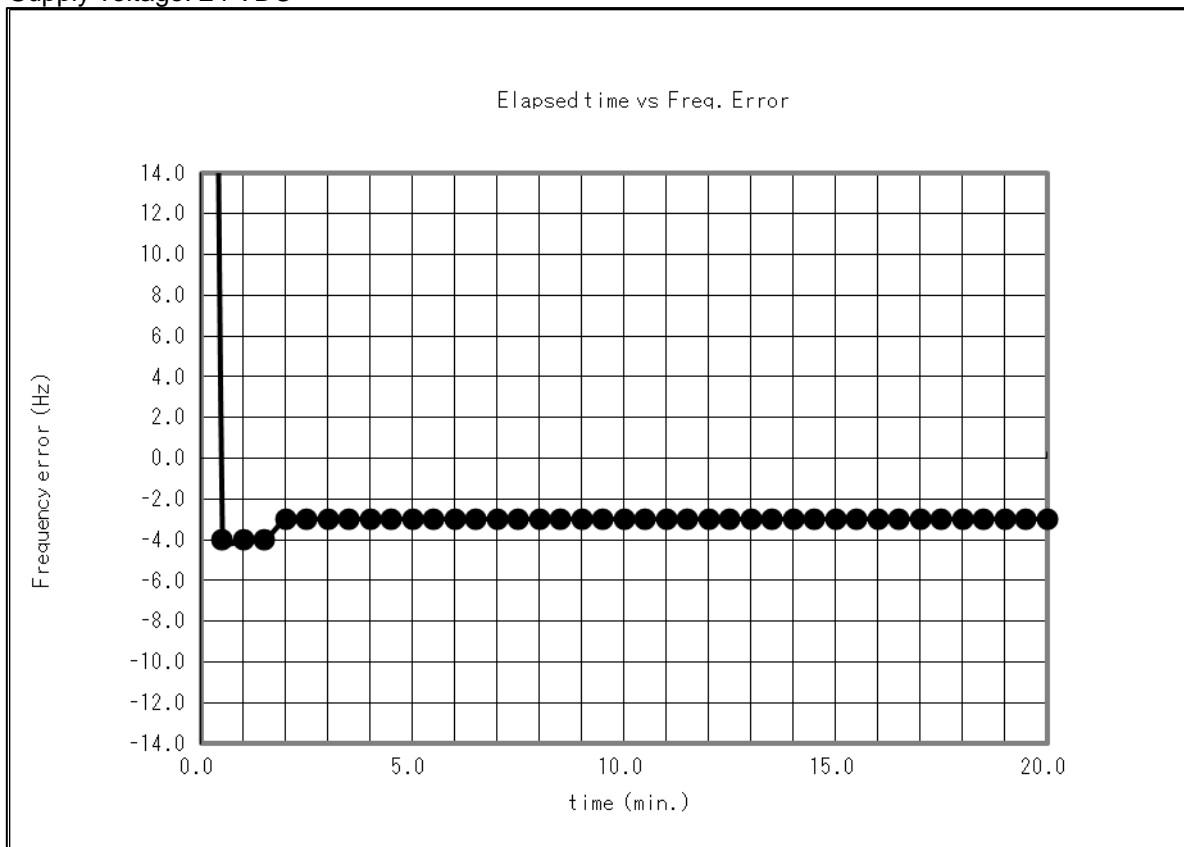

Fig. 3.7.3

Frequency stability (Cold start (0°C))
Supply voltage: 24 VDC

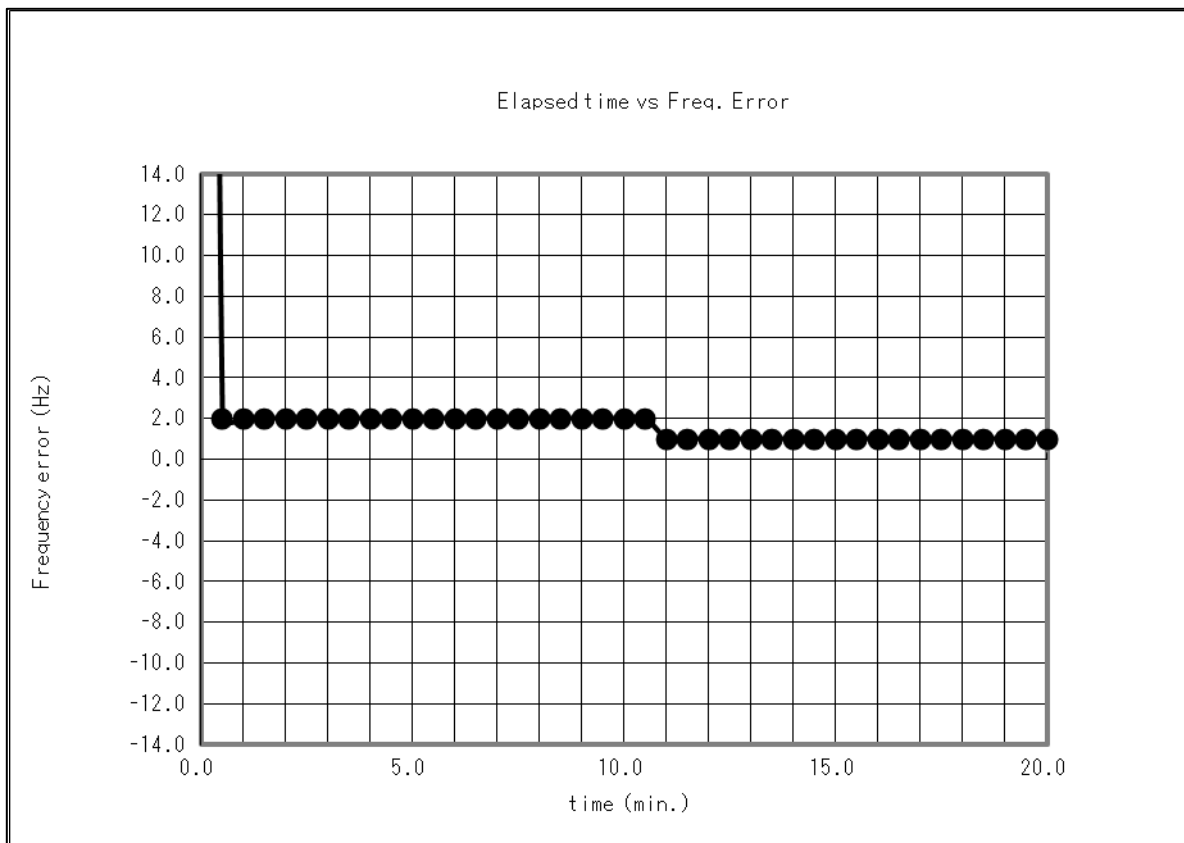

Fig. 3.7.4

Frequency stability (Cold start (+30°C))
Supply voltage: 24 VDC

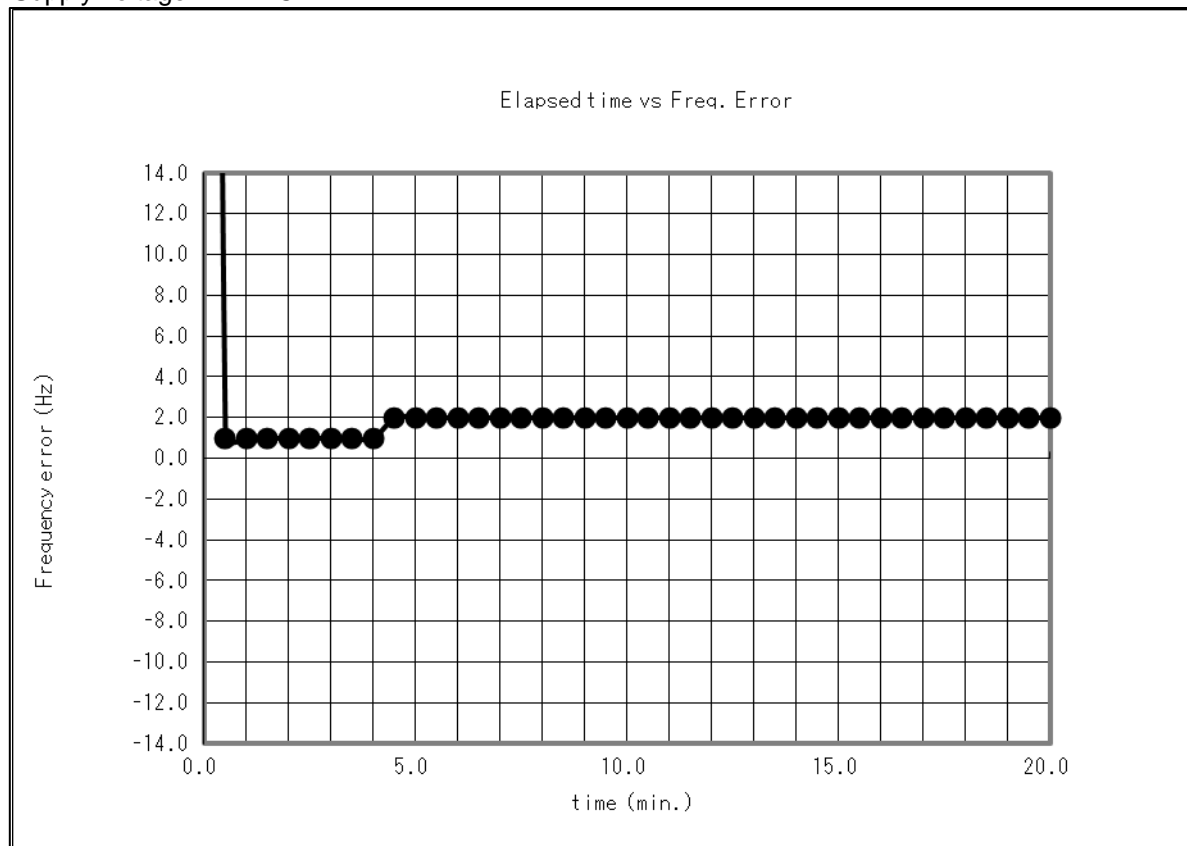

Fig. 3.7.5

Environmental conditions observed: On 12 March 2012, 20°C to 20°C, 40% to 40%RH
24.0 VDC to 24.0 VDC

On 13 March 2012, 20°C to 20°C, 44% to 44%RH
24.0 VDC to 24.0 VDC

On 14 March 2012, 19°C to 20°C, 46% to 48%RH
24.0 VDC to 24.0 VDC

4 List of Measuring/Test Instruments

Measuring/Test instruments have been appropriately calibrated/maintained according to the FLI programs/procedures and ISO/IEC 17025. Measuring/Test instruments used for the tests are listed below.

4.1 FIELD STRENGTH OF SPURIOUS RADIATION

Instrument	Type	S/N	Manufacturer
Spectrum analyzer (9 kHz to 3 GHz)	R3132	110401654	Advantest
Loop antenna (0.15 MHz to 30 MHz)	HFH2-Z2	100093	Rohde & Schwarz
Amplifier (for Loop antenna)	310N	250607	Sonoma Instrument
Biconical antenna (30 MHz to 300 MHz)	VBA6106A	1296	Schaffner
Pre-amplifier (30 MHz to 2 GHz)	87405A	3207A01643	Agilent
Semi-anechoic Chamber	3mSAC	D-002	Riken
DC Power Supply	PR-850A	19811 4030	Furuno

4.2 FREQUENCY STABILITY

Instrument	Type	S/N	Manufacturer
Digital Multimeter	115	15540244	Fluke
Climatic chamber (Nishinomiya-S)	PL-4KP	14004204	Tabai Espec
DAQSTATION FX100	FX106-4-1	S5JA01450	Yokogawa

4.3 Measuring/Test Instruments submitted by the customer for evaluating the EUT performance

4.3.1 RF POWER OUTPUT

Instrument	Type	S/N	Manufacturer	Calibration date
MXA Signal Analyzer	N9020A	US47140216	Agilent	27 July 2011
Power Sensor	8482A	2237A07374	Agilent	27 September 2011
Power Meter	E4418B	MY40511008	Agilent	21 September 2011
Multi function Synthesizer	8904A	2948A04574	Agilent	8 August 2011
Resistance Attenuator	RA-920A	1090014	Kenwood	9 November 2011
Attenuator	600-A-9FFN-30	4240-062	Bird	----
Attenuator	VAT-10W2	1139	MCL	----
DC Power Supply	PR-850A	19811 4030	Furuno	----

4.3.2 MODULATION CHARACTERISTICS

4.3.2.1 Audio Frequency Response

Instrument	Type	S/N	Manufacturer	Calibration date
MXA Signal Analyzer	N9020A	US47140216	Agilent	27 July 2011
Power Sensor	8482A	2237A07374	Agilent	27 September 2011
Power Meter	E4418B	MY40511008	Agilent	21 September 2011
Multi function Synthesizer	8904A	2948A04574	Agilent	8 August 2011
Resistance Attenuator	RA-920A	1090014	Kenwood	9 November 2011
Attenuator	600-A-9FFN-30	4240-062	Bird	----
Attenuator	VAT-10W2	1139	MCL	----
DC Power Supply	PR-850A	19811 4030	Furuno	----

4.3.2.2 Power Limiting vs Audio Input Voltage

Instrument	Type	S/N	Manufacturer	Calibration date
MXA Signal Analyzer	N9020A	US47140216	Agilent	27 July 2011
Power Sensor	8482A	2237A07374	Agilent	27 September 2011
Power Meter	E4418B	MY40511008	Agilent	21 September 2011
Multi function Synthesizer	8904A	2948A04574	Agilent	8 August 2011

Instrument	Type	S/N	Manufacturer	Calibration date
Resistance Attenuator	RA-920A	1090014	Kenwood	9 November 2011
Attenuator	600-A-9FFN-30	4240-062	Bird	----
Attenuator	VAT-10W2	1139	MCL	----
DC Power Supply	PR-850A	19811 4030	Furuno	----

4.3.3 OCCUPIED BANDWIDTH

Instrument	Type	S/N	Manufacturer	Calibration date
MXA Signal Analyzer	N9020A	US47140216	Agilent	27 July 2011
Power Sensor	8482A	2237A07374	Agilent	27 September 2011
Power Meter	E4418B	MY40511008	Agilent	21 September 2011
Multi function Synthesizer	8904A	2948A04574	Agilent	8 August 2011
Resistance Attenuator	RA-920A	1090014	Kenwood	9 November 2011
Attenuator	600-A-9FFN-30	4240-062	Bird	----
Attenuator	VAT-10W2	1139	MCL	----
DC Power Supply	PR-850A	19811 4030	Furuno	----

4.3.4 EMISSION LIMITATIONS

Instrument	Type	S/N	Manufacturer	Calibration date
MXA Signal Analyzer	N9020A	US47140216	Agilent	27 July 2011
Power Sensor	8482A	2237A07374	Agilent	27 September 2011
Power Meter	E4418B	MY40511008	Agilent	21 September 2011
Multi function Synthesizer	8904A	2948A04574	Agilent	8 August 2011
Resistance Attenuator	RA-920A	1090014	Kenwood	9 November 2011
Attenuator	600-A-9FFN-30	4240-062	Bird	----
Attenuator	VAT-10W2	1139	MCL	----
DC Power Supply	PR-850A	19811 4030	Furuno	----

4.3.5 SPURIOUS EMISSIONS AT ANTENNA TERMINAL

Instrument	Type	S/N	Manufacturer	Calibration date
MXA Signal Analyzer	N9020A	US47140216	Agilent	27 July 2011
Power Sensor	8482A	2237A07374	Agilent	27 September 2011
Power Meter	E4418B	MY40511008	Agilent	21 September 2011
Multi function Synthesizer	8904A	2948A04574	Agilent	8 August 2011
Resistance Attenuator	RA-920A	1090014	Kenwood	9 November 2011
Attenuator	600-A-9FFN-30	4240-062	Bird	----
Attenuator	VAT-10W2	1139	MCL	----
DC Power Supply	PR-850A	19811 4030	Furuno	----

4.3.6 FIELD STRENGTH OF SPURIOUS RADIATION

Instrument	Type	S/N	Manufacturer	Calibration date
Audio analyzer	U8903A	MY50070005	Agilent	18 March 2011
Power Meter	DJ-522-0H-2	46507	Tokyo Denpa	13 October 2011
Resistance Attenuator	RA-920A	1090049	Kenwood	10 August 2011

4.3.7 FREQUENCY STABILITY

Instrument	Type	S/N	Manufacturer	Calibration date
Frequency Counter	5385A	2730A05114	Hp (Agilent)	10 August 2011
DC Power Supply	GP060-10	1013895093	TAKASAGO	----