

## 6. MENU OPERATION

- 1) Rotate the **ENTER** knob to select [+0.00 kHz] then push the knob.

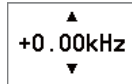

- 2) Rotate the **ENTER** knob to adjust the receiving frequency (setting value: -0.20 to +0.20).

### 6.13 External Alarm Setting

The [EXTERNAL ALARM] menu enables/disables output of the contact signal for urgency, safety and routine frequencies to an external alarm system.

1. Rotate the **ENTER** knob to select [SYSTEM] on the [MENU] screen then push the knob.
2. Rotate the **ENTER** knob to select [EXTERNAL ALARM] then push the knob.



3. Rotate the **ENTER** knob to select [URGENCY], [SAFETY] or [ROUTINE], then push the knob.
4. Rotate the **ENTER** knob to select [ON] or [OFF] then push the knob.

### 6.14 NETWORK Setting

View your network settings on the [NETWORK SETTING (VIEW)] screen.

1. Rotate the **ENTER** knob to select [SYSTEM] on the [MENU] screen then push the knob.
2. Rotate the **ENTER** knob to select [NETWORK] then push the knob.

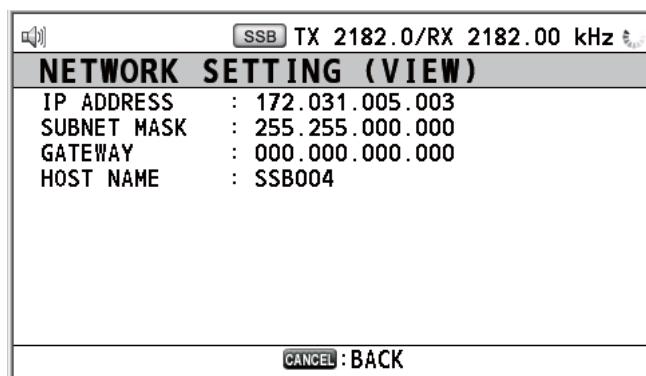

## 6.15 Address Book

You can register a maximum of 50 MMSI or the address name (max. 20 letters) in the memory.

### 6.15.1 List for address data

1. Rotate the **ENTER** knob to select [DSC] on the [MENU] screen then push the knob.
2. Rotate the **ENTER** knob to select [ADDRESSBOOK] then push the knob.

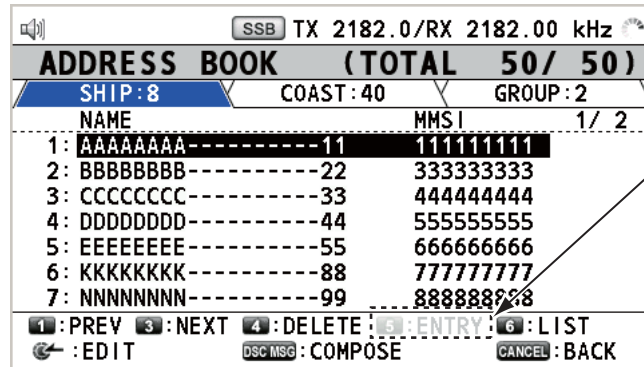

When 50 addresses are registered, this is not available.

Key/knob	Function
<b>ENTER</b>	<ul style="list-style-type: none"> <li>• Move the cursor by rotating the <b>ENTER</b> knob.</li> <li>• Open the [ADDRESS DATA EDIT] screen by pushing the <b>ENTER</b> knob (see paragraph 6.15.3)..</li> </ul>
<b>CANCEL</b>	Return to the [MENU] screen.
<b>1</b>	Go to the previous page.
<b>3</b>	Go to the next page.
<b>4</b>	Delete address (see paragraph 6.15.4).
<b>5</b>	Open the [ADDRESS DATA ENTRY] screen (see paragraph 6.15.2).
<b>6</b>	Switch the address type. Each press changes the type continuously (SHIP → COAST → GROUP → SHIP → ...).

### 6.15.2 How to register addresses

1. Open the [ADDRESS BOOK] screen.
2. Press the **5** key to open the [ADDRESS DATA ENTRY] screen.

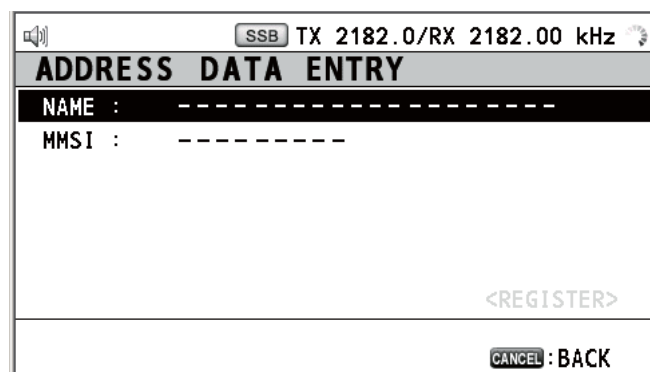

## 6. MENU OPERATION

3. With [NAME] selected, push the **ENTER** knob.

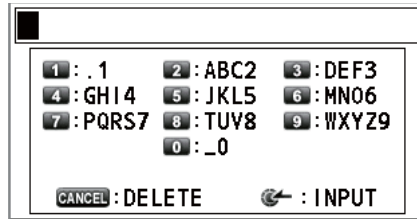

4. Enter the address name (max. 20 letters) with the numeric keys then push the **ENTER** knob.
5. With [MMSI] selected, push the **ENTER** knob.



6. Enter the MMSI with the numeric keys then push the **ENTER** knob.
7. With [REGISTER] selected, push the **ENTER** knob.

### 6.15.3 How to edit addresses

1. Open the [ADDRESS BOOK] screen.
2. Rotate the **ENTER** knob to select the address to edit then push the knob.

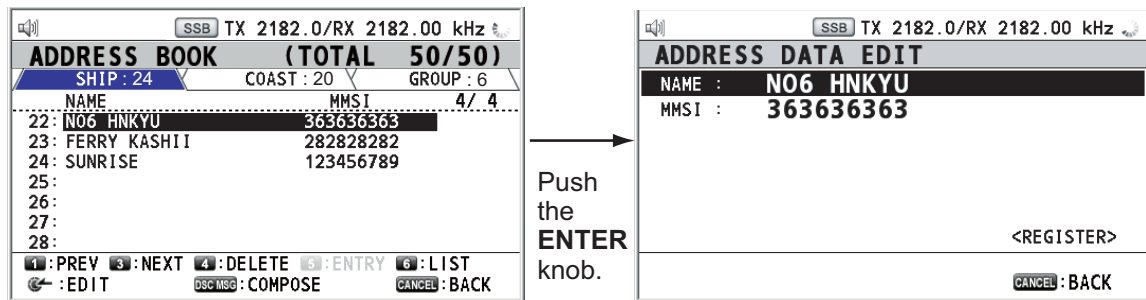

3. Rotate the **ENTER** knob to select [NAME] or [MMSI] as appropriate then push the knob.
4. Enter the address name or MMSI with the numeric keys then push the **ENTER** knob.
5. Rotate the **ENTER** knob to select [REGISTER] then push the knob.

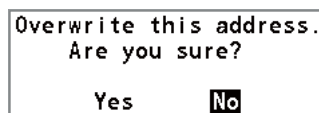

**Note:** If the MMSI is already registered to another address, the error alarm sounds and a warning pop-up message appears when selecting [REGISTER].

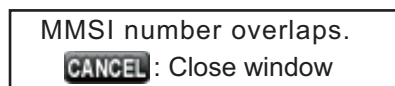

6. Rotate the **ENTER** knob to select [Yes] then push the knob.

### 6.15.4 How to delete addresses

Open the [ADDRESS BOOK] screen then follow the applicable procedure below.

#### Individual address

1. Rotate the **ENTER** knob to select the address to delete then press the **4** key.

<b>DELETE SELECTION</b>
DELETE LIST
DELETE ALL LISTS

2. With [DELETE SELECTION] selected, push the **ENTER** knob.

Are You Sure?
Yes <b>No</b>

3. Rotate the **ENTER** knob to select [Yes] then push the knob.

#### Address by type

1. Press the **6** key several times to select desired type.
2. Press the **4** key.
3. Rotate the **ENTER** knob to select [DELETE LIST] then push the knob.
4. Rotate the **ENTER** knob to select [Yes] then push the knob.

#### All addresses

1. Press the **4** key.
2. Rotate the **ENTER** knob to select [DELETE ALL LISTS] then push the knob.
3. Rotate the **ENTER** knob to select [Yes] then push the knob.

### 6.15.5 How to create a DSC message with registered address

1. Open the [ADDRESS BOOK] screen.
2. Rotate the **ENTER** knob to select the address to use.
3. Press the **OTHER DSC MSG** key to open the [COMPOSE MESSAGE] screen.

SSB TX 2182.0/RX 2182.00 kHz	
<b>ADDRESS BOOK (TOTAL 50/50)</b>	
SHIP : 24	COAST : 20 GROUP : 6
NAME	MMSI 4/ 4
22: N06 HNKYU	363636363
23: FERRY KASHII	282828282
24: SUNRISE	123456789
25:	
26:	
27:	
28:	
1: PREV 3: NEXT 4: DELETE 5: ENTRY 6: LIST	
EDIT DSC MSG: COMPOSE CANCEL: BACK	

Press the **OTHER DSC MSG** key.

SSB TX 2182.0/RX 2182.00 kHz	
<b>COMPOSE MESSAGE</b>	
MSG TYPE : <b>INDIVIDUAL MSG</b>	
TO :	<b>363636363</b> N06 HNKYU
PRIORITY :	<b>ROUTINE</b>
COMM MODE :	<b>TELEPHONE</b>
COMM FREQ :	<b>2170.0kHz</b>
DSC FREQ :	<b>2177.0kHz</b>
CANCEL: BACK GO TO CALL	

## 6.16 TX Message Preparation

For the individual, PSTN, group and test messages, you can create messages and store them in the memory for future use. You can edit, send or delete these messages. A maximum of 100 messages can be stored into the memory.

### 6.16.1 List for message files

1. Rotate the **ENTER** knob to select [DSC] on the [MENU] screen then push the knob.
2. Rotate the **ENTER** knob to select [MSG FILE] then push the knob.

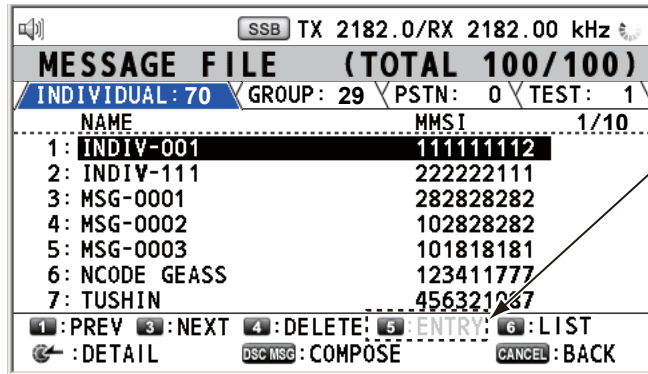

When 100 messages are registered, this is not available.

Key/knob	Function
<b>ENTER</b>	<ul style="list-style-type: none"> <li>• Move the cursor by rotating the <b>ENTER</b> knob.</li> <li>• Open the detailed information screen for the selected message file by pushing the <b>ENTER</b> knob (see the following "Detailed information screen for message files").</li> </ul>
<b>CANCEL</b>	Return to the [MENU] screen.
<b>1</b>	Go to the previous page.
<b>3</b>	Go to the next page.
<b>4</b>	Delete messages (see paragraph 6.16.8).
<b>5</b>	Open the [MESSAGE FILE ENTRY] screen.
<b>6</b>	Switch the message type. Each press changes the type continuously (INDIVIDUAL → GROUP → PSTN → TEST → INDIVIDUAL → ...).

#### Detailed information screen for message files

Rotate the **ENTER** knob to select the message file desired on the [MESSAGE FILE] list then push the knob. The detailed information screen for the selected message file appears as shown right.

Several functions can be done from this screen.

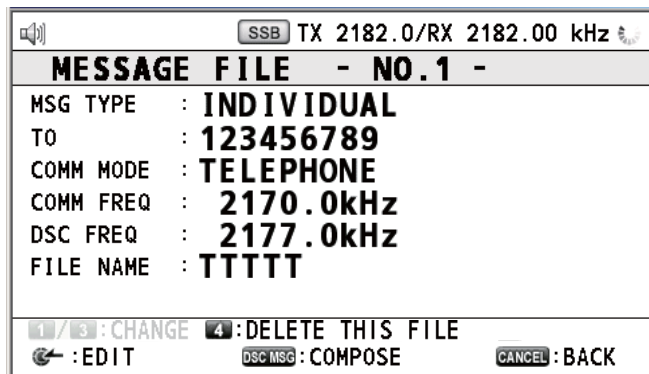

- **1** key: Go to the detailed information screen for the previous message file.

- **3** key: Go to the detailed information screen for the next message file.
- **4** key: Delete the selected message file. The following message appears on the screen.

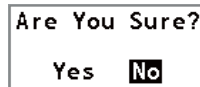

Rotate the **ENTER** knob to select [Yes] then push the knob.

## 6.16.2 Individual calls

1. Open the [MESSAGE FILE] list.
2. Press the **5** key to open the [MESSAGE FILE ENTRY] screen.

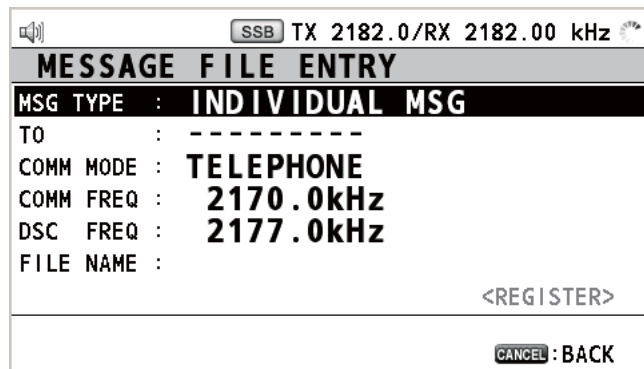

3. With [MSG TYPE] selected, push the **ENTER** knob.



4. Rotate the **ENTER** knob to select [INDIVIDUAL MSG] then push the knob.
5. With [TO] selected, push the **ENTER** knob.
6. Rotate the **ENTER** knob to select [DIRECT INPUT] or [ADDRESS BOOK DATA] then push the knob.  
[ADDRESS BOOK DATA]: Select a MMSI from the [ADDRESS BOOK] (see section 6.15) then push the **ENTER** knob.  
[DIRECT INPUT]: Enter the MMSI of coast station or ship station with the numeric keys then push the **ENTER** knob.
7. With [COMM MODE] selected, push the **ENTER** knob.
8. Rotate the **ENTER** knob to select the communication mode then push the knob.
9. Rotate the **ENTER** knob to select [DSC FREQ] then push the knob.
10. Rotate the **ENTER** knob to select DSC frequency referring to "How to set DSC frequency" on page 5-2 then push the knob. The communication frequency changes in conjunction with DSC frequency. If you change the communication frequency, go to step 11. If not, go to step 13.
11. Rotate the **ENTER** knob to select [COMM FREQ] then push the knob.



12. Set the communication frequency referring to "How to set working channel, frequency" on page 5-3 then push the **ENTER** knob.

## 6. MENU OPERATION

13. Rotate the **ENTER** knob to select [FILE NAME] then push the **ENTER** knob.

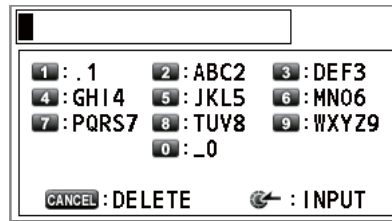

14. Enter the file name (max. 20 letters) with the numeric keys.
15. With [REGISTER] selected, push the **ENTER** knob.

### 6.16.3 Group calls

To receive group calls, register the group MMSI as follows:

1. Open the [MESSAGE FILE] list.
2. Press the **5** key to open the [MESSAGE FILE ENTRY] screen.
3. With [MSG TYPE] selected, push the **ENTER** knob.
4. Rotate the **ENTER** knob to select [GROUP MSG] then push the knob.
5. With [TO] selected, push the **ENTER** knob.
6. Enter the group MMSI (eight digits) with the numeric keys then push the **ENTER** knob.
7. With [COMM MODE] selected, push the **ENTER** knob.
8. Rotate the **ENTER** knob to select [TELEPHONE] or [NBDP-FEC] then push the knob.
9. Rotate the **ENTER** knob to select [DSC FREQ] then push the knob.
10. Rotate the **ENTER** knob to select DSC frequency referring to "How to set DSC frequency" on page 5-2 then push the knob. The communication frequency changes in conjunction with DSC frequency. If you change the communication frequency, go to step 11. If not, go to step 13.
11. Rotate the **ENTER** knob to select [COMM FREQ] then push the knob.
12. Set the communication frequency referring to "How to set working channel, frequency" on page 5-3 then push the **ENTER** knob.
13. With [FILE NAME] selected, push the **ENTER** knob.
14. Enter the file name (max. 20 letters) with the numeric keys.
15. With [REGISTER] selected, push the **ENTER** knob.

### 6.16.4 PSTN calls

1. Open the [MESSAGE FILE] list.
2. Press the **5** key to open the [MESSAGE FILE ENTRY] screen.
3. With [MSG TYPE] selected, push the **ENTER** knob.
4. Rotate the **ENTER** knob to select [PSTN MSG] then push the knob.
5. With [TO] selected, push the **ENTER** knob.
6. Enter the MMSI of coast station (seven digits) with the numeric keys then push the **ENTER** knob.
7. With [TEL] selected, push the **ENTER** knob.

8. Enter the telephone no. (up to 16 digits) with the numeric keys then push the **ENTER** knob.
9. With [DSC FREQ] selected, push the **ENTER** knob.
10. Rotate the **ENTER** knob to select DSC frequency referring to "How to set DSC frequency" on page 5-2 then push the knob.
11. With [FILE NAME] selected, push the **ENTER** knob.
12. Enter the file name (max. 20 letters) with the numeric keys.
13. With [REGISTER] selected, push the **ENTER** knob.

### 6.16.5 Test call

1. Open the [MESSAGE FILE] list.
2. Press the **5** key to open the [MESSAGE FILE ENTRY] screen.
3. With [MSG TYPE] selected, push the **ENTER** knob.
4. Rotate the **ENTER** knob to select [TEST MSG] then push the knob.
5. With [TO] selected, push the **ENTER** knob.
6. Rotate the **ENTER** knob to select [DIRECT INPUT] or [ADDRESS BOOK DATA] then push the knob.  
 [ADDRESS BOOK DATA]: Select a MMSI from the [ADDRESS BOOK] (see section 6.15) then push the **ENTER** knob.  
 [DIRECT INPUT]: Enter the MMSI where to send the test message with the numeric keys then push the **ENTER** knob.
7. With [DSC FREQ] selected, push the **ENTER** knob.

<b>2187.5kHz</b>
4207.5kHz
6312.0kHz
8414.5kHz
12577.0kHz
16804.5kHz

8. Rotate the **ENTER** knob to select DSC frequency desired then push the knob.
9. With [FILE NAME] selected, push the **ENTER** knob.
10. Enter the file name (max. 20 letters) with the numeric keys.
11. With [REGISTER] selected, push the **ENTER** knob.

### 6.16.6 How to edit prepared messages

1. Open the [MESSAGE FILE] list.
2. Rotate the **ENTER** knob to select the message file to edit then push the knob.



## 6. MENU OPERATION

3. Push the **ENTER** knob to open [MESSAGE FILE EDIT] screen.

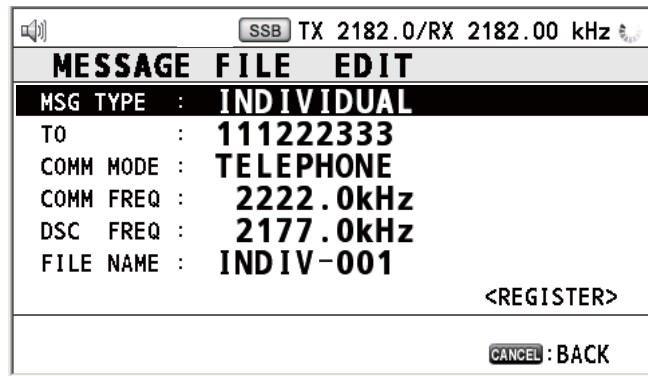

4. Rotate the **ENTER** knob to select the item to edit then push the knob.
5. Change the setting accordingly.
6. Rotate the **ENTER** knob to select [REGISTER] then push the knob.

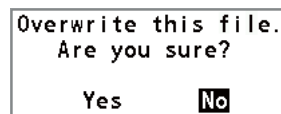

7. Rotate the **ENTER** knob to select [Yes] then push the knob.

### 6.16.7 How to send prepared messages

#### How to send without modification

1. Open the [MESSAGE FILE] list.
2. Rotate the **ENTER** knob to select the message file desired then press the **OTHER DSC MSG** key.
3. Rotate the **ENTER** knob to select [GO TO CALL] then push the knob.

#### Edit before sending

Follow the procedure in paragraph 6.16.6 and do the above procedure "How to send without modification".

### 6.16.8 How to delete prepared messages

#### Individual prepared message

Open the [MESSAGE FILE] list then follow the applicable procedure below.

1. Rotate the **ENTER** knob to select the file to delete then press the **4** key.



2. With [DELETE SELECTION] selected, push the **ENTER** knob.

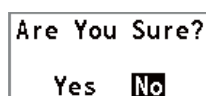

3. Rotate the **ENTER** knob to select [Yes] then push the knob.

**Prepared messages by type**

1. Press the **6** key several times to select the desired type.
2. Press the **4** key.
3. Rotate the **ENTER** knob to select [DELETE LIST] then push the knob.
4. Rotate the **ENTER** knob to select [Yes] then push the knob.

**All prepared messages**

1. Press the **4** key.
2. Rotate the **ENTER** knob to select [DELETE ALL LISTS] then push the knob.
3. Rotate the **ENTER** knob to select [Yes] then push the knob.

## 6.17 How to Set the AUTO ACK Details

The acknowledgement message can be sent automatically when you receive an individual message or a PSTN message. You can also enable or disable it for position, polling and test messages. For PSTN, position and polling messages, automatic acknowledgement is disabled with an active DSC session.

**Note 1:** For individual message, the automatic acknowledgement is automatically disabled, as required by law, when an RX call contains an error.

**Note 2:** For individual message, the auto acknowledgement message can not be sent when there are RT and/or DSC sessions.

1. Rotate the **ENTER** knob to select [DSC] on the [MENU] screen then push the knob.
2. Rotate the **ENTER** knob to select [ACK SETTINGS] then push the knob.

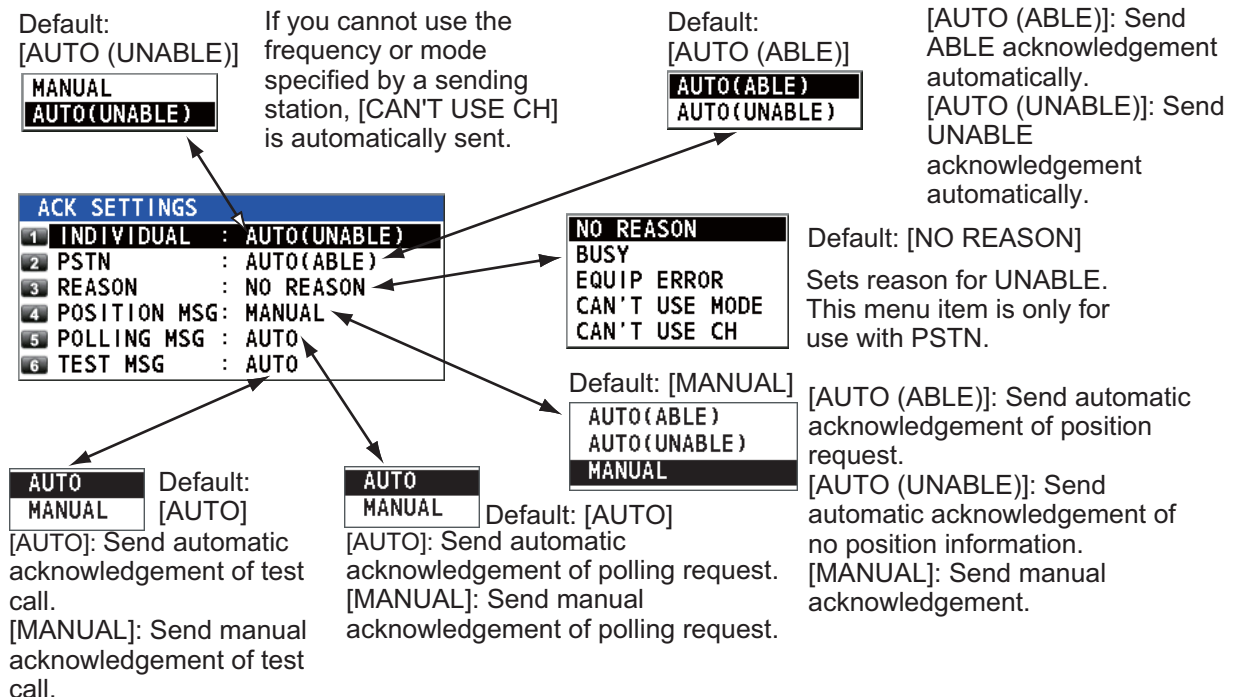

## 6.18 Special Messages

Permission to transmit NEUTRAL CRAFT and MEDICAL TRANSPORT is enabled or disabled as follows:

1. Rotate the **ENTER** knob to select [DSC] on the [MENU] screen then push the knob.
2. Rotate the **ENTER** knob to select [SPECIAL MSG] then push the knob.

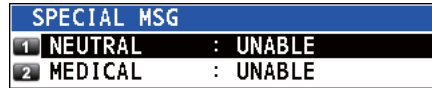

3. Rotate the **ENTER** knob to select [NEUTRAL] or [MEDICAL] then push the knob.
4. Rotate the **ENTER** knob to select [ABLE] or [UNABLE] then push the knob.

## 6.19 How to Set Scan Frequencies

The [ROUTINE/DISTRESS SCAN] menus determine which DSC routine and distress frequencies to scan. Follow the instructions below to select/deselect DSC routine and distress frequencies to scan.

### Routine frequencies

1. Rotate the **ENTER** knob to select [DSC] on the [MENU] screen then push the knob.
2. Rotate the **ENTER** knob to select [ROUTINE SCAN] then push the knob.

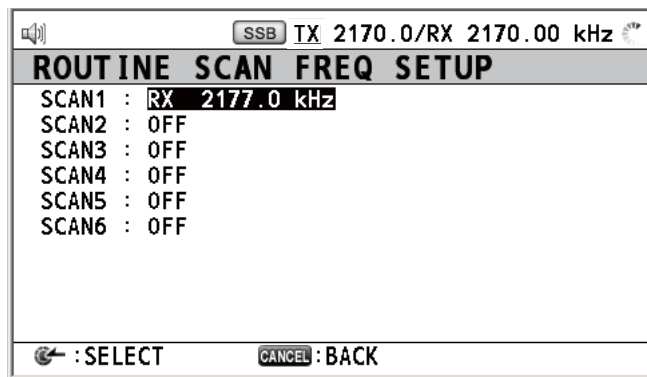

3. Rotate the **ENTER** knob to select [SCAN1] (2, 3, 4, 5 or 6) then push the knob.

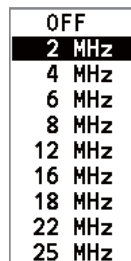

4. Rotate the **ENTER** knob to select frequency band then push the knob.
5. Rotate the **ENTER** knob to select frequency desired then push the knob.  
 [INTL]: International channels  
 [LOCAL1/LOCAL2]: Local channels  
 [DIST]: Distress channels

**Note:** Distress frequencies can be stored on the routine frequency memory. This is convenient for backing up the watch-keeping receiver.

### **Distress, urgency and safety frequencies**

1. Rotate the **ENTER** knob to select [DSC] on the [MENU] screen then push the knob.
2. Rotate the **ENTER** knob to select [DISTRESS SCAN] then push the knob.

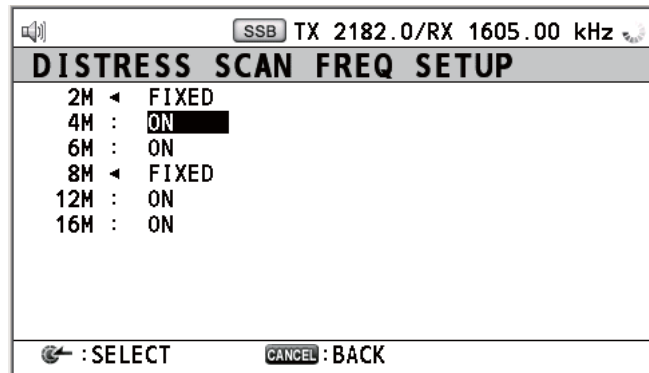

3. Rotate the **ENTER** knob to select frequency band then push the knob.

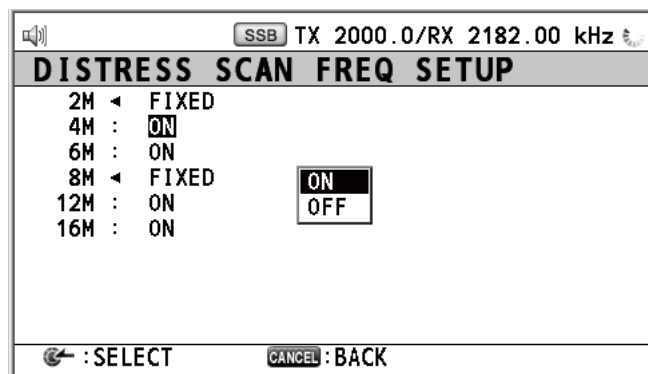

4. Rotate the **ENTER** knob to select [ON] or [OFF] as appropriate then push the knob.

**Note:** Regulations require that 2 MHz and 8 MHz and one more DSC distress frequency should be watched continuously. 2 MHz and 8 MHz cannot be turned off. Maximum three bands can be turned off.

## 6.20 Sound Setting

The [AUDIO] menu lets you set the volume for the following items:

- Key click on (setting: [1] - [3]) or off (setting: [0]) (Two beeps sound when a key inoperative in the ON mode (setting: [1] - [3]) is operated.)
- Speaker on or off with off hook for handset
- Volume of the receiving alarm for the safety and routine messages
- Turn sound alarm on or off for the distress alarm received from a ship in distress which is more than 500 NM from your ship.

Rotate the **ENTER** knob to select [AUDIO] on the [MENU] screen then push the knob.

## 6. MENU OPERATION

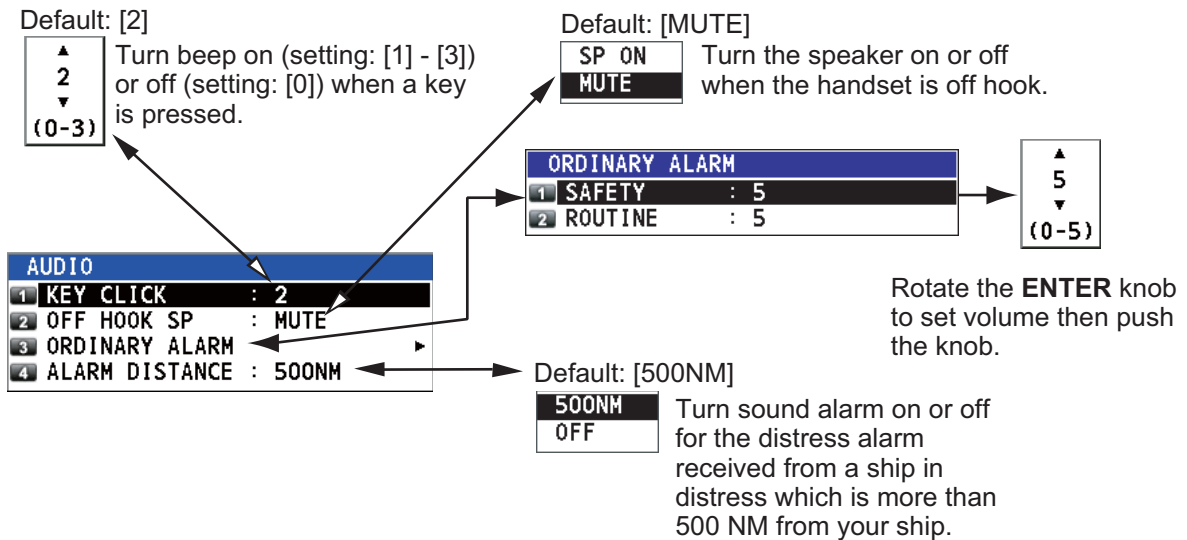

### 6.21 Alarm Lists

The [ALARM] menu shows all currently violated alarms. When an error occurs, a pop-up message and the flashing error icon appear on the screen. Press the **CANCEL** key to close the pop-up message and stop the flashing of the error icon. When the error is removed, the error icon disappears.

Rotate the **ENTER** knob to select [ALARM] on the [MENU] screen then push the knob. The following screen appears.

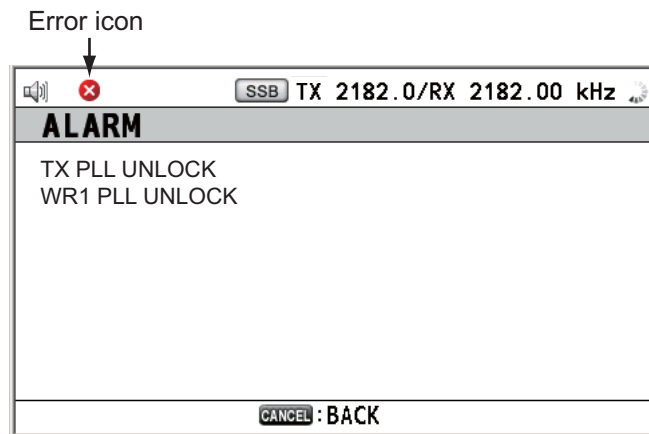

There are seven kinds of errors: TX PLL UNLOCK, RX PLL UNLOCK, WR1 PLL UNLOCK, WR2 PLL UNLOCK, MAIN AMP HEATED, SHIP'S MAIN FAILURE, VC ERROR.

Errors are displayed in the order shown above, not in the order of occurrence. An error is deleted from the list when the cause for the error is removed.

# 7. NBDP SYSTEM OVERVIEW

## 7.1 How to Turn on the NBDP System

Turn on the terminal unit and the printer with their respective power switches.

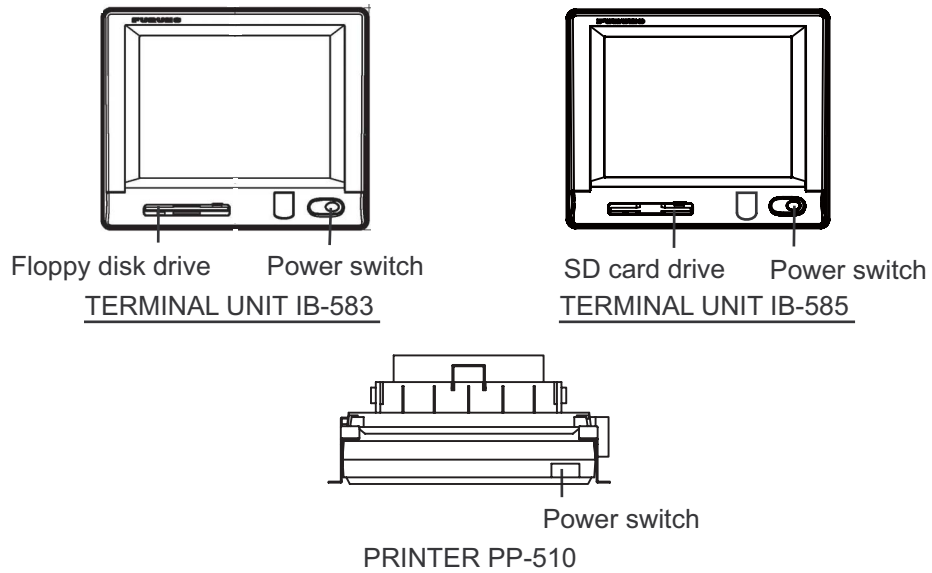

**Note 1:** To power on the system, turn on the control unit then turn on the NBDP terminal unit.

**Note 2:** The printer PP-510 prints messages. Refer to its operator's manual for operation.

## 7.2 Description of Equipment

### 7.2.1 Terminal unit

The terminal unit is a visual display incorporating a floppy disk drive (for IB-583) or an SD card drive (IB-585). To adjust the brilliance, press the **Alt** key while pressing the **F6** key to lower the brilliance; the **F7** key to raise it. Eight levels of brilliance are available.

When the terminal unit is turned on, the communication status screen, shown below, appears. This is where all phases of telex communications begin.

```
1:File 2:Edit 3:Operate 4:Window 5:Station 6:System 7:WRU 8:HR 9:Over 10:Break
-----:10-Apr-2012: 15:10:30 UTC ----- Caps-Eng
Station Name      :
Frequency (T/R)  :      . /      . (kHz)  Comm Mode : AUTO
Comm Status      : Connect Send Lock Error
Sending Volume   :      (%)  ARQ Error : 0  ARQ Time : 0(sec)
```

*Communication status screen*

**Features of the IB-583**

The IB-583 has a battery (Type: CR2450-F2ST2L, Code no.: 000-144-941) on its TERM/CPU Board (16P0209) and its life is about six years. When the voltage of the battery gets low, the time is wrong. When this occurs, contact your dealer about replacement of the battery.

**Russian mode**

The terminal unit is fitted with both English and Russian modes. Select the desired mode as below:

"English-mode": Turn on the terminal unit while pressing the **E** key.

"Russian-mode": Turn on the terminal unit while pressing the **R** key.

This mode is stored.

In "Russian-mode", there are two input shift status; "English-shift" and "Russian-shift". In the "Russian-shift" status, the alphabet keys are used as Cyrillic keys.

**Note 1:** To switch between Russian and English input, press the **Alt** key while holding down the **Shift** key. (This is available in Russian mode only.) "Eng" or "Rus" appears on the top right of the screen. This shift status is not stored. When you turn on the power next time, you reset the shift status as necessary.

**Note 2:** The comma and period can not be entered in the "Russian-shift" status. To enter these characters, switch to the "English-shift" status.

**Note 3:** "Ё" and "Ъ" can not be entered in "Russian-mode". "У" is replaced with "4" in NBDP communication.

**7.2.2 Keyboard**

The terminal unit is operated from the keyboard. Operation is simplified by the use of menus which you access by pressing a function key, labeled F1-F10 at the top of the keyboard. The figures below show the function menus and their corresponding function keys.

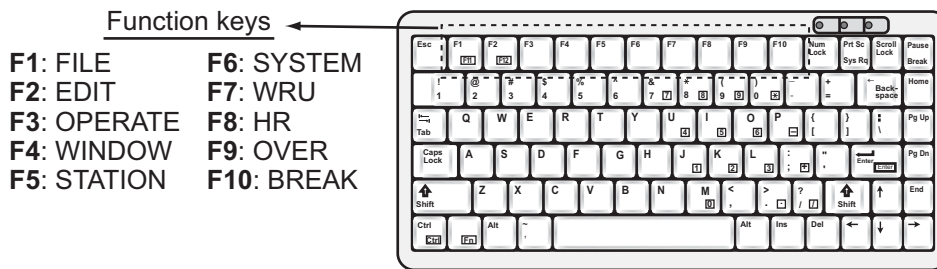

*Keyboard for IB-583*

The indication "ScrLk" means the Russian shift is active. (It does not mean "scroll lock".)  
Do not use these keys.

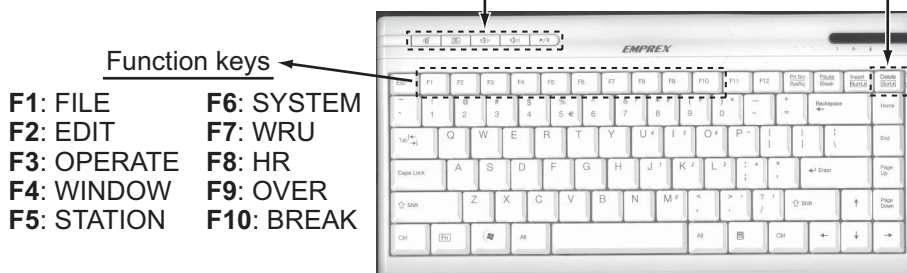

*Keyboard for IB-585*

**Note 1:** The correct letters may not be entered when connecting a keyboard except the supplied one.

**Note 2:** Both Russian and English input are available in the Russian mode. Put the keytop label supplied on the keyboard during the Russian mode.

**Note 3:** The carriage-return and line-feed codes "CR LF" are automatically sent with pressing the **Enter** key during NBDP communication. Press the ← or ↓ key if you want to send only "CR" or "LF".

**Note 4:** "Letter Shift" and "Figure Shift" are automatically inserted if necessary. If you want to send them purposely, press the following keys:

- "Letter Shift": **Ctrl + Shift + L**
- "Figure Shift": **Ctrl + Shift + F**
- "NOINF" ("Cyrillic Shift" in Russian mode): **Ctrl + Shift + R**

**Note 5:** Do not connect or disconnect the keyboard during operating the terminal unit.

## 7.3 Function Keys, Menu Operation

The function keys at the top of the keyboard control most of operations through a menu system. Most of the screenshots on this manual are for IB-585.

### 7.3.1 Menu conventions

#### Reverse highlighting

The cursor-selected menu item is displayed with white characters on a black background.

#### Underline

The underline shows the currently selected option. In the figure below, for example, [ARQ], [Channel] and [ON] are underlined.

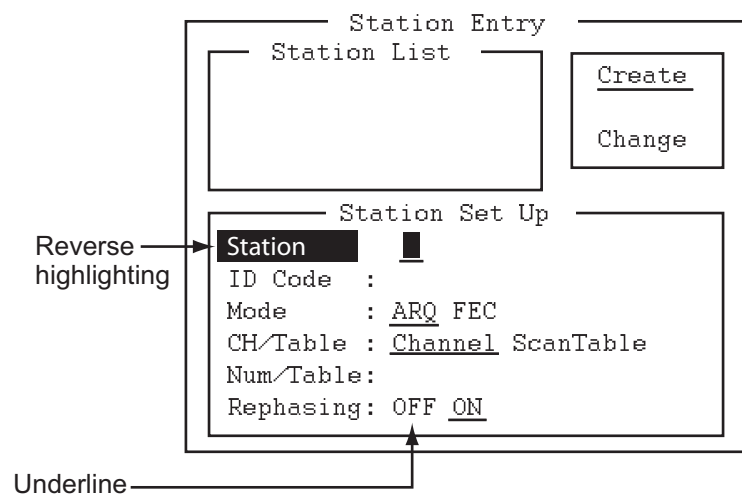

*[Station Entry] screen*



### 7.3.2 Menu overview

#### Menu selection

Press a function key to open a menu. To display the [File] menu, for example, press the function key **F1**.

#### Selection of menu items and options

Press a numeric or alphabet key to select a menu item. You can also select a menu item to press the ← or → key then press the **Enter** key. Menu options can be selected by the ← or → key. After selecting an option, press the **Enter** key to register your selection.

#### How to close the menu

Press and hold down the **Esc** key for over a second to close the menu.

```

File
1: New
2: Open
3: Close
-----
4: Delete
-----
5: Rename
-----
6: Real Time Printing
7: File to Print
8: Cancel Printing
-----
9: Clear Buffer
-----
0: SD Card Format

A: Remove SD Card
B: New Macro

```

### 7.3.3 Function key description

#### Function key F1: [File] menu

The [File] menu is where you create, open, save and print telex messages. Floppy disks or SD cards are also formatted by this menu.

```

File
1: New
2: Open
3: Close
-----
4: Delete
-----
5: Rename
-----
6: Real Time Printing
7: File to Print
8: Cancel Printing
-----
9: Clear Buffer
-----
0: SD Card Format*1

A: Remove SD Card*2
B: New Macro*2

```

\*1: [Floppy Disk Format] for IB-583

\*2: Only for IB-585

- 1:** Open a new untitled window.
- 2:** Open files saved on floppy disks or SD cards.
- 3:** Close files with saving or discarding.
- 4:** Delete files on floppy disks or SD cards.
- 5:** Rename files on floppy disks or SD cards.
- 6:** Turn real time printing on or off.
- 7:** Print files on floppy disks or SD cards.
- 8:** Stop printing and clear the print buffer.
- 9:** Clear the communication buffer.
- 0:** Format an SD card for IB-585, or a floppy disk for IB-583.
- A:** Execute this menu before removing an SD card.
- B:** Open a macro window.

**Function key F2: [Edit] menu**

The [Edit] menu provides a full line of editing features.

Edit	
1: Undo	-----
2: Cut	
3: Copy	
4: Paste	-----
5: Select All	-----
6: Search	
7: Replace	-----
8: Goto Top	
9: Goto Bottom	
0: Goto Line	-----
A: Change Text	

- 1:** Cancel the last change (cut, copy or paste).
- 2:** Remove the selected text and store it in the paste buffer. (Previous text in the paste buffer is cleared.)
- 3:** Copy the selected text and store it in the paste buffer. (Previous text in the paste buffer is cleared.)
- 4:** Insert the text stored in the paste buffer at the current location of the cursor.
- 5:** Select the entire current file for cut or copy.
- 6:** Search a word or a character string.
- 7:** Replace a word with a different word or character string.
- 8:** Put the cursor to the top line of the current file.
- 9:** Put the cursor to the last line of the current file.
- 0:** Move the cursor to the desired line in the current file.
- A:** Switch between the display window 1 and 2.

**Function key F3: [Operate] menu**

The [Operate] menu mainly controls transmission and reception.

Operate	
1: Call Station	
2: Macro Operation	-----
3: File to Send	
4: Cancel Sending	-----
5: Scan (Start/Stop)	-----
6: Manual Reception	-----
7: Timer Operation	-----
8: Manual Calling	
9: Set Frequency	
0: Set Channel*	

- 1:** Select a station on the station list.
- 2:** Enable macro operation. For details, see section 10.10.
- 3:** Select a file (to transmit).
- 4:** Stop sending a file.
- 5:** Start/stop frequency scanning.
- 6:** Select communication mode for reception; AUTO, ARQ, FEC.
- Note:** Do not select DIRC.
- 7:** Timer programming.
- 8:** Set TX mode and subscriber's ID number and start manual calling.
- 9:** Set TX and RX frequencies and start waiting for reception.
- 0:** Set ITU or user channel and start waiting for reception.

\*: Only for IB-585

**Function key F4: [Window] menu**

The [Window] menu lets you display the corresponding data of the window below.

Window		
1: Calendar	-----	
2: Distress Frequency Table	-----	
3: Screen Saver*	OFF	ON

\*: Only for IB-585

- 1:** Display desired calendar month and year. To change year or month, select item with the ↑ or ↓ key and change setting with the ← or → key.
- 2:** Display all distress frequencies (see the following table).
- 3:** Turn on or off the screen saver function. For details, see section 8.7.

Distress Frequencies						
Telephone (kHz):	2182.0	4125.0	6215.0	8291.0	12290.0	16420.0
-----						
NBDP (kHz) :	2174.5	4177.5	6268.0	8376.5	12520.0	16695.0
-----						
DSC (kHz) :	2187.5	4207.5	6312.0	8414.5	12577.0	16804.5

**Function key F5: [Station] menu**

The [Station] menu provides for storage of stations, timer program setup, user channel setup, and entry of various ID codes.

Station	
1: Station Entry	-----
2: Timer Operation Entry	-----
3: Scan Entry	-----
4: User Channel Entry*	-----
5: Answerback Code Entry	-----
6: Group ID Entry (4/5 digit)	
7: Group ID Entry (9 digit)	
8: Select ID Entry (4/5 digit)	
9: Select ID Entry (9 digit)	

\*: Only for IB-583

- 1:** Register stations.
  - 2:** Register timer programs.
  - 3:** Register scan groups for scanning.
  - 4:** Register user channels.
  - 5:** Register own ship's answerback code.
  - 6:** Register own ship's group ID code (4 or 5 digits).
  - 7:** Register own ship's group ID code (9 digits).
  - 8:** Register own ship's selective ID code (4 or 5 digits).
  - 9:** Register own ship's selective ID code (9 digits).
- Note:** For IB-585, the numbers after 5 are moved up.

**Function key F6: [System] menu**

The [System] menu is mainly for use by technicians and contains diagnostic tests. To change settings, select [Change] from the item [Setup] and operate the arrow keys to select item and option. Press the **Enter** key to register the selection and close the menu.

System	
Setup	Lock Change Default
-----	
Slave Delay	12 msec (10 - 50 msec)
-----	
TX/RX MSG Save	<u>OFF</u> ON
Edit before Sending	<u>OFF</u> ON
TX Power*	<u>HIGH</u> MID LOW
Header/Footer*	<u>OFF</u> ON
-----	
Time System	OFF <u>UTC</u> SMT JST
Time & Date	10-Apr-2012 10:00:00
Window Color	
Self Test	

\*: Only for IB-585

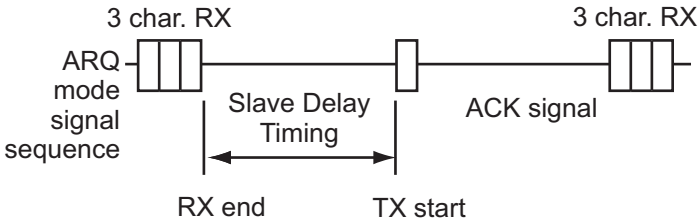
Menu item	Function
[Setup]	Lock, change settings, restore default system settings.
[Slave Delay]	<p>Set the length of the slave delay timing from the end of RX to the start of TX in the ARQ mode. The default setting is suitable in most cases. This item cannot be adjusted by the user.</p>  <p>The diagram illustrates the timing sequence in ARQ mode. It shows a 3-character RX signal followed by an ARQ mode signal sequence. A double-headed arrow labeled 'Slave Delay Timing' indicates the interval between the end of the RX signal ('RX end') and the start of the TX signal ('TX start'). Following the TX start, an ACK signal is received, which is also a 3-character RX signal.</p>
[TX/RX MSG Save]	Turn on to automatically save incoming and outgoing messages to a floppy disk or a SD card. "Log" appears at the top of the screen when on.
[Edit Before sending]	[OFF] transmits key operation one by one. [ON] transmits message only when the <b>Enter</b> key is pressed after confirming text typed.
[TX POWER] (only for IB-585)	Change output power during transmission. ([HIGH], [MID], [LOW] (for FS-1575/2575), [LOW1] (for FS-5075), [LOW2] (for FS-5075))
[Header/Footer] (only for IB-585)	Turn on or off the indication of header and footer. When starting transmission, display time & date for starting transmission, MMSI for communication party, TX and RX frequencies. When ending transmission, display time & date for ending transmission.
[Time System]	Select time system. [OFF]: No time indication, [UTC]: Coordinated universal time, [SMT]: Local time, [JST]: Japan standard time

## 7. NBDP SYSTEM OVERVIEW

Menu item	Function
[Time & Date]	Enter date and time manually. If a navigation device is connected, the time is automatically set when the power is turned on or whenever the time system is switched. Manual entry takes priority over automatic entry. This item cannot be adjusted when using [UTC] or [JST].
[Window Color]	Select display colors. For details, see section 8.6.
[Self Test]	Start diagnostic test.

### **Function key F7: WRU (Who Are You?)**

In the ARQ mode, request other station's answerback code.

### **Function key F8: HR (Here Is)**

In the ARQ mode, send your ship's answerback code.

### **Function key F9: OVER**

In the ARQ mode, switch the direction of traffic; the information receiving station switches to the information sending station, the information sending station switches to the information receiving station.

### **Function key F10: Break**

Disconnect the line or cancel the standby.

# 8. NBDP PREPARATIONS

---

This chapter provides the procedures necessary for preparing the NBDP terminal unit. For automatic telex, you need to register the following:

- Your ship's ID and answerback codes mandatory
- Stations
- Timer programs
- Scan channel groups
- User channels

## 8.1 Registration of Answerback & ID Codes

Enter your ship's answerback and ID codes as shown below.

**Note:** The answerback and ID codes cannot be changed once entered; be sure to correctly enter the codes.

### 8.1.1 How to register answerback code

1. Press the function key **F5** then the **4** key for IB-585 or the **5** key for IB-583 to open the [Answerback Code Entry] screen.

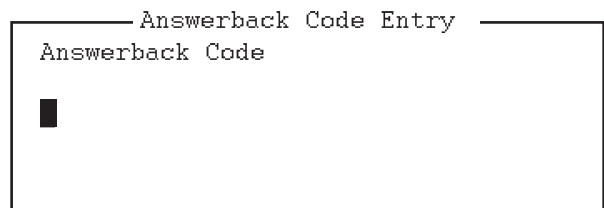

2. Enter your ship's answerback code (numbers, space, 4 capital letters, space, X) then press the **Enter** key. The prompt "OK/Cancel" asks for confirmation of the data.  
Example of answerback code: 123456789 FURU X.
3. If the code is correct, press the **Enter** key again. For final confirmation of the data, the "Caution" shown in the illustration below appears.

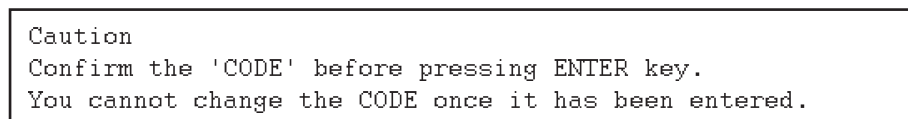
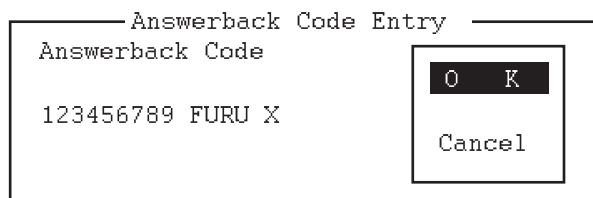

*Message for confirmation of code entered*

4. If the code is correct, press the **Enter** key again.

### 8.1.2 How to register ID codes

1. Press the function key **F5** then the **5**, **6**, **7** or **8** key for IB-585 to enter the Group ID Code (4 or 5 digits), Group ID Code (9 digits), Select ID Code (4 or 5 digits) or Select ID Code (9 digits), respectively. (For IB-583, press the function key **F5** then the **6**, **7**, **8** or **9** key.)

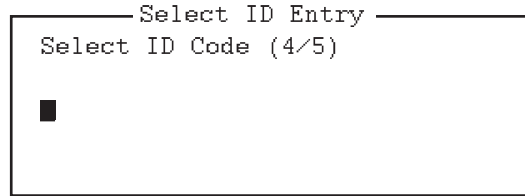

2. Enter Group ID or Select ID then press the **Enter** key. A prompt asks for confirmation of the data.
3. If the ID is correct, press the **Enter** key. For final confirmation of the data, the "Caution" shown in the illustration below appears.

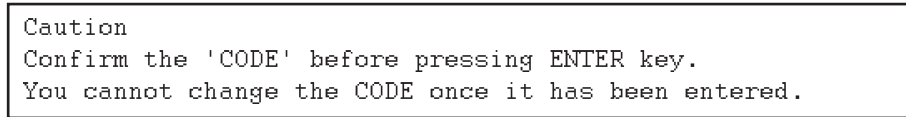
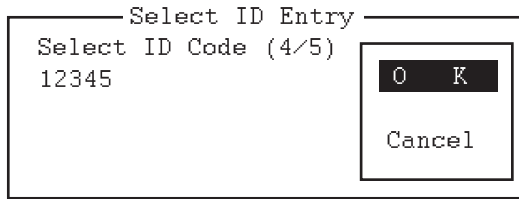

*Message for confirmation of code entered*

4. If the ID is correct, press the **Enter** key again.

## 8.2 User Channels

The user channels can be used in scanning entry and station entry.

For IB-585, the user channels are set by the transceiver unit. See section 6.2. For IB-583, the user channel list provides storage for up to 100 user channels, numbered 0 - 99. See the following paragraphs.

### 8.2.1 How to register user channels

1. Press the function key **F5** then the **4** key to open the [User Channel Entry] screen.

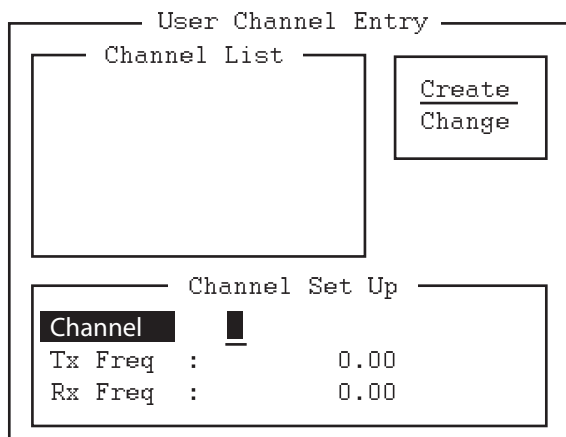

2. If [Create] is not underlined, press the →, ↑ and **Enter** keys to underline it.

3. With [Channel] selected, enter a channel number.  
**Note 1:** 100 channels can be registered. When you attempt to register more, the message "Channel memory is full. Press any key to escape." appears. In this case delete unnecessary channels to register new ones.  
**Note 2:** If the channel entered already exists, the message "Channel by that number already exists. Press any key to escape." appears. Press any key then enter another number.
4. Press the ↓ key to select [Tx Freq]. Enter TX frequency.
5. Press the ↓ key to select [Rx Freq]. Enter RX frequency.
6. Press the **Enter** key. The [OK/Cancel] confirmation window appears.
7. Press the **Enter** key. Channel number entered appears in the [Channel List].
8. Press the **Esc** key to close the menu.

### 8.2.2 How to edit/delete user channels

1. Press the function key **F5** then the **4** key to open the [User Channel Entry] screen.
2. Press the ↓ key to select a channel from the [Channel List].
3. Press the → key then the ↓ key to select [Change] and press the **Enter** key.
4. Do one of the following:  
 Edit channel: Use the ↑, ↓ and **Backspace** keys to make corrections.  
 Delete channel: Erase channel number with the **Backspace** key.
5. Press the **Enter** key twice.
6. Press the **Esc** key.

## 8.3 Station List

The station list stores up to 50 stations, one frequency pair (RX and TX) per station. For stations which have more than one frequency pair, you can add a suffix to the station name to denote multiple frequency pairs. For example, station name FURUNO followed by -1, -2, -3, etc. for each frequency pair required.

### 8.3.1 How to register stations

1. Press the function key **F5** then the **1** key to open the [Station Entry] screen. On the right side of the screen, [Create] and [Change] are shown.



## 8. NBDP PREPARATIONS

2. If [Create] is not underlined, press the →, ↑ and **Enter** keys to underline it.
3. With [Station] selected, enter station name using up to 18 characters.
4. Press the ↓ key to select [ID Code]. Enter station ID code.
5. Press the ↓ key to select [Mode]. Select either communication mode with the ← or → keys.  
[ARQ]: Automatic Retransmission Request  
[FEC]: Forward Error Correction
6. Press the ↓ key to select [CH/Table]. Select [Channel] or [ScanTable].
7. Press the ↓ key to select [Num/Table].  
If you selected [Channel] at step 6, enter ITU channel number (see Appendix 2) or User channel number. Go to step 10.  
If you selected [ScanTable] at step 6, press the → key to show the scan group list registered. For the scan group, refer to section 8.5.
8. Select a scan group name by using the ↓ or ↑ key then press the **Enter** key. For IB-583, go to step 10. For IB-585, go to the next step.

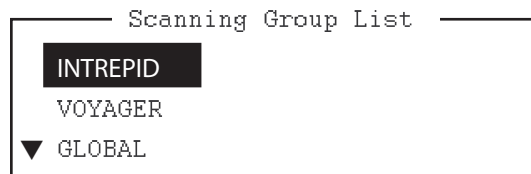

*Example window for Scanning Group List*

9. Press the ↓ key to select [Rephasing]. Select [ON] or [OFF].  
**Note:** The default setting is [ON]. Select [ON] under normal use. The disconnection by error is processed quickly with [OFF] when communicating with the party which does not have rephasing function.
  10. Press the **Enter** key. The prompt [OK/Cancel] asks for verification of data.
- 
- A small rectangular window with a thin border. It contains two options: "O K" is highlighted with a dark background, and "Cancel" is displayed in plain text below it.
11. If the data is correct, press the **Enter** key. (To cancel entry, press the ↓ key to select [Cancel] then press the **Enter** key. Data entered are erased.) The station name entered at step 3 appears at the [Station List] window.
  12. To register other stations, press the **Enter** key twice then repeat steps 3 through 10.
  13. Press the ↓ key. Check data on the [Station List] for correctness. The stations displayed in reverse video on the [Station List] are displayed on [Station Set Up].
  14. Press the **Esc** key to quit.

**Note 1:** If you enter a station which already exists, the indication "Station by that name already exists. Press any key to escape." appears. Press any key to return to the [Station List]. Check the list.

**Note 2:** The station entry beginning with "DSC" is special entry which is automatically registered by DSC function.

### 8.3.2 How to edit/delete stations

1. Press the function key **F5** then the **1** key to open the [Station Entry] screen.
2. Press the  $\downarrow$  key to select a station name from the [Station List].
3. Press the  $\rightarrow$  key then the  $\downarrow$  key to select [Change] and press the **Enter** key.
4. Do one of the following;  
 Edit station: Use the  $\uparrow$ ,  $\downarrow$  and the **Backspace** keys to make corrections.  
 Delete station: Erase station name with the **Backspace** key.
5. Press the **Enter** key twice.
6. Press the **Esc** key.

## 8.4 Timer Programming

A built-in timer allows you to automatically receive and transmit files. 10 timer programs can be registered. To enable timer operation, see section 10.6.

### 8.4.1 How to register timer programs

1. Press the function key **F5** then the **2** key to open the [Timer Operation Entry] screen.

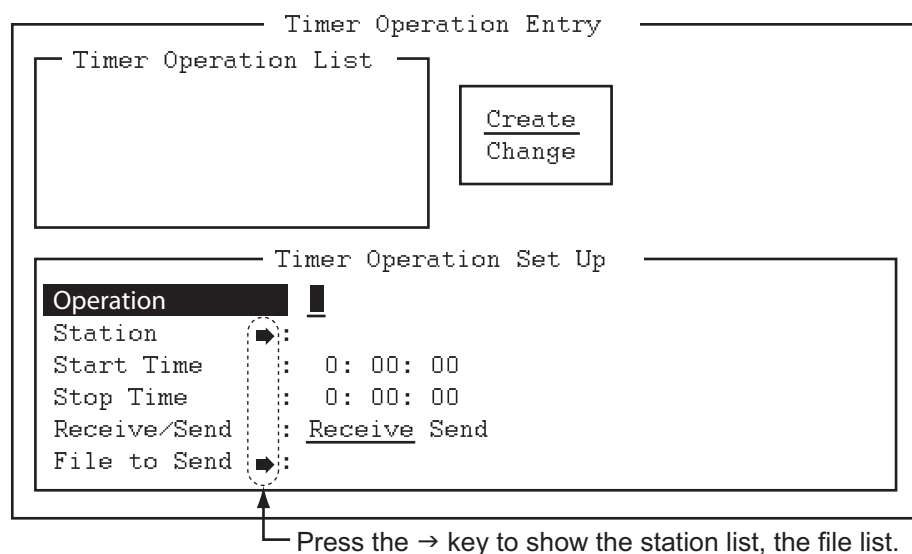

2. If [Create] is not underlined, press the  $\rightarrow$ ,  $\uparrow$  and **Enter** keys to underline it.
3. With [Operation] selected, enter a suitable operation name on the [Operation] line. Any alphanumeric characters can be used.  
**Note:** If the operation name entered already exists, the message "Operation name already exists. Press any key to escape." appears. Press any key and change the operation name.
4. Press the  $\downarrow$  key to select [Station].
5. Press the  $\rightarrow$  key to display [Station List] (which you registered stations in the previous paragraph).
6. Press the  $\downarrow$  or  $\uparrow$  key to select a station then press the **Enter** key.
7. Press the  $\downarrow$  key to select [Start Time]. Enter start time, in 24-hour notation. To have the operation start at 8:35 a.m., for example, the keying sequence would be **0 8 3 5 0 0**.

## 8. NBDP PREPARATIONS

8. Press the ↓ key to select [Stop Time]. Enter stop time, in 24-hour notation.
9. Press the ↓ key to select [Receive/Send]. Select operation category; [Receive] or [Send]. If you select [Send], go to step 10. For [Receive], go to step 12.
10. For [Send], insert the floppy disk or the SD card to the drive then press the ↓ key to select [File to Send].
11. Press the → key to open the TX window, select a file, then press the **Enter** key twice.
12. Press the **Enter** key. A confirmation message appears.
13. Press the **Enter** key. The operation name appears in [Timer Operation List].
14. To enter another timer program, press the **Enter** key twice and repeat steps 3 to 13.
15. Press the **Esc** key to close the menu.

### 8.4.2 How to edit/delete timer programs

1. Press the function key **F5** then the **2** key to open the [Timer Operation Entry] screen.
2. Press the ↓ key to select a timer program name from the [Timer Operation List].
3. Press the → key then the ↓ key to select [Change] and press the **Enter** key.
4. Do one of the following;  
Edit program: Use the ↓, ↑ and the **Backspace** keys to make corrections.  
Delete program: Erase operation name with the **Backspace** key.
5. Press the **Enter** key twice.
6. Press the **Esc** key.

## 8.5 Scan Channel Groups

You can store up to 10 scan groups, 20 channels per group.

The NBDP terminal unit can control radio equipment through channel scanning. In the FEC mode, the radio equipment scans a number of channels (according to your selection), stopping when a synchronous code is found. In the ARQ mode it stops when your own ID code is detected in an incoming signal. Also, in the ARQ mode, the transmitter is then tuned to the corresponding transmitter frequency, the communication link is established and the traffic is automatically exchanged. Scanning resumes once the link is disconnected.

### 8.5.1 How to register scan channel groups

You can register ITU and user scan channels as follows:

1. Press the function key **F5** then the **3** key to open the [Scan Entry] screen.

Scan Entry

Scanning Group List

Create

Change

---

Scanning Set Up

Group Name : █

Ch Dwell Time : 4.5 sec (2.7-4.5 sec)

Receiving Mode\* : AUTO ARQ FEC

Auto Search : OFF ON

---

No.	Channel	Rx Freq	Tx Freq	Pass/Scan
0				Pass/Scan
1				Pass/Scan
2				Pass/Scan
3				Pass/Scan
4				Pass/Scan
5				Pass/Scan
6				Pass/Scan

Press the ↓ key to scroll the screen.      \*: [Mode] for IB-583

2. If [Create] is not underlined, press the →, ↑ and **Enter** keys to underline it.
3. With [Group Name] selected, enter a suitable group name.
 

**Note 1:** 10 group names can be entered. If you attempt to enter more, the message "Scan group memory is full. Press any key to escape." appears. Press any key then delete unnecessary group names to enter new ones.

**Note 2:** If the group name already exists, the message "Scan group by that name already exists. Press any key to escape." appears. Press any key and change the scan group name.
4. Press the ↓ key to select [Ch Dwell Time]. Enter channel dwell time in seconds. Dwell time is the time in seconds the receiver waits on each channel in a scan group before it selects the next frequency.
5. Press the ↓ key to select [(Receiving) Mode] then select the receiving mode; [AUTO], [ARQ] or [FEC].
 

**Note:** [AUTO] is used to register a scanning channel group when both [ARQ] and [FEC] exist in the same Scanning Channel Group. When you select a scan group by the [Call Station] menu, the communication mode is controlled by the station entry's mode.
6. Press the ↓ key to select [Auto Search]. Select [ON] or [OFF].
 

[ON]: The radio stops scanning when it finds the strongest signal (highest S/N ratio). To find the strongest signal, the radio scans all channels, which can take some time. Therefore, use this setting where the signal propagation is poor.

[OFF]: The radio stops scanning on the first signal it finds. It is recommended to select [OFF] when the signal propagation is good.
7. Press the ↓ key to select line No. 1 in the [Scanning Set Up] window.

## 8. NBDP PREPARATIONS

8. Enter the channel number (ITU or user channels) then press the → key to select [Scan].  
**Note:** If you enter an invalid channel, the message "Channel by that number does not exist. Press any key to escape." appears. Press any key then enter a valid channel.
9. Press the ↓ key to select line No. 2. Enter a channel number.
10. Enter other channel numbers then press the **Enter** key. A confirmation message appears.
11. Press the **Enter** key again to save the data. The group name is displayed in the [Scanning Group List] window.
12. To continue, press the **Enter** key twice then repeat steps 3 to 11.
13. Press the **Esc** key to close the menu.  
**Note 1:** An ARQ from another station continues for 56 seconds. However, you cannot receive via ARQ if the number of registered scan frequencies multiplied by the channel dwell time is greater than 56 seconds.  
**Note 2:** The selective FEC mode requires authentication of call ID. However, you cannot receive via the selective FEC mode if the Call ID is not received with the frequency for scan detention time. If you might be called via the selective FEC mode, wait to receive the call on a single frequency, which you can set with the [Set Frequency] in the [Operate] menu.

### 8.5.2 How to edit/delete scan channel groups

1. Press the function key **F5** then the **3** key to open the [Scan Entry] screen.
2. Press the ↓ key to select scan group name from the [Scanning Group List].
3. Press the → key then the ↓ key to select [Change] and press the **Enter** key.
4. Press the ↓ key to place the cursor on the field (channel) to change.
5. Do one of the following:  
Edit channels: Press the **Backspace** key to delete the channel number then enter a new channel number.  
Add channels: Enter a channel number on a blank line.  
Delete scan group: Delete the group name with the **Backspace** key.  
Disable channels temporarily: Press the ← key to underline [Pass].
6. Press the **Enter** key twice.
7. Press the **Esc** key to close the menu.

## 8.6 How to Change the Window Color

You can select and change the window color.

### **IB-583**

1. Select [Change] from [Setup].
2. Press the ↓ key to select [Window Color] then press the **Enter** key.

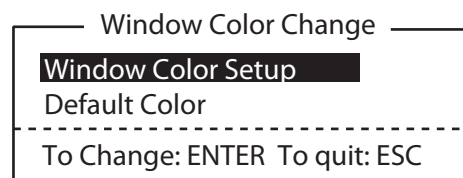

3. With [Window Color Setup] selected, press the **Enter** key.
4. Press the ← or → key to select the item to change: [BASE WINDOW], [BACK SCROLL], [EDIT 1-2], [FUNCTION], [SUB MENU 1-3], [MESSAGE].
5. Press the ↓ key to select [Fore Color].
6. Press the ← or → key to select color: [L-WHITE], [BLACK], [BLUE], [GREEN], [CYAN], [RED], [MAGENTA], [BROWN], [WHITE], [GRAY], [L-BLUE], [L-GREEN], [L-CYAN], [L-RED], [L-MAGENTA], [YELLOW].
7. Press the ↓ key to select [Back Color].
8. Press the ← or → key to select color.
9. Press the ↑ key to select [Window].
10. Repeat the steps 4 to 9 to set other colors.
11. Press the **Enter** key followed by the **Esc** key.

Window Color Setup		
Window	: [BASE WINDOW	]
Fore Color	: [L-WHITE	]
Back Color	: [BLUE	]
-----		
To Change: ENTER		To Change Value: L<=>R

### **IB-585**

1. Press the function key **F6** to open the [System] menu.
2. Press the → key to select [Change].
3. Press the ↓ key to select [Window Color] then press the **Enter** key to open the [Window Color Edit] window.

Window Color Edit		
Target Preset	<b>1</b>	2 3
Load Default		
-----		
Edit Color		
Window	[	BASE WINDOW ]
Fore Color	[	BLACK ]
Back Color	[	WHITE ]
Brightness	0 1 2 3 4 5 6 7 8 9	<u>10</u>
-----		
To Change: ENTER		To Change Value: L<=>R

4. Press the ← or → key to select [1], [2] or [3]. The selected preset color is reflected on the [Window Color Edit] window.

5. Press the **Enter** key to reflect the selected preset color on the screen.

If you want to reset or change the preset settings, do the following:

1. Select [1], [2] or [3] then press the ↓ key.
2. To reset the settings, press the **Enter** key with [Load Default] selected.  
To change the settings, press the ↓ key. Go to step 3.
3. Press the ← or → key to select an option in [Window] and press the ↓ key.
4. Press the ← or → key to select a color in [Fore Color] and press the ↓ key.
5. Press the ← or → key to select a color in [Back Color] and press the ↓ key.  
**Note:** You cannot select the same color between [Fore Color] and [Back Color].
6. To increase the brightness, press the **F7** key while pressing and holding the **Alt** key. To decrease the brightness, press the **F6** key while pressing and holding the **Alt** key. The changed brightness setting is underlined.
7. To confirm the selections, press the **Enter** key. To cancel the selections, press the **Esc** key. The window closes.

*Default for each preset*

		Preset1 (original)	Preset2 (day)	Preset3 (night)
Brightness		10	10	5
Base window	Fore color	L-White	Black	L-White
	Back color	Blue	L-White	Black
Back scroll	Fore color	L-White	Black	Black
	Back color	Blue	White	Gray
Edit1	Fore color	Black	Black	Black
	Back color	Green	White	Gray
Edit2	Fore color	Magenta	Black	White
	Back color	White	L-Cyan	Blue
Function	Fore color	Black	Black	L-White
	Back color	Cyan	L-White	Black
Sub menu1	Fore color	Black	Blue	L-Cyan
	Back color	White	L-White	Black
Sub menu2	Fore color	Blue	Blue	L-Green
	Back color	White	White	Black
Sub menu3	Fore color	White	L-White	L-Magenta
	Back color	Black	Blue	Black
Message	Fore color	White	L-White	White
	Back color	Magenta	Blue	Blue

## 8.7 Screen Saver Function for IB-585

Turn on or off the screen saver function for IB-585. When there are no operation for 10 minutes, the screen is black and "IB-585" appears at random.

**Note:** This function is not available during standby and communication modes.

1. Press the function key **F4** then the **3** key to select [Screen Saver].

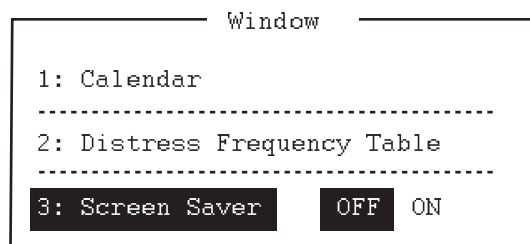

2. Press the → key to select [ON].
3. Press the **Enter** key to close the menu.

# 9. NBDP FILE OPERATIONS

This chapter mainly describes how to create, save, open, edit and print files. The [Edit] menu provides a full lineup of editing facilities, including search and replace.

## 9.1 How to Open and Close Files

To create a telex message, you need to make a new file with the File Open command. When you open a new file, it is placed (opened) in one of two working areas. When both working areas are occupied, you must close a file to open a new file. This is done with the File Close command.

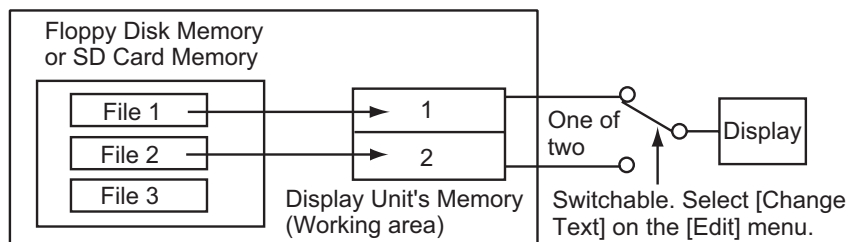

*How to open a file*

## 9.2 How to Create Files

There are two modes for creating the files; for messages and for macros.

- For messages: You can enter only the characters which are sendable in NBDP communication. Press the function key **F1** then the **1** key to create a message file.
- For macros: You can enter only the characters ( \$ @ \_ | ) which are used in a macro command. Press the function key **F1** then the **B** key to create a macro file.

1. Press the function key **F1** to open the [File] menu.



\*1: [Floppy Disk Format] for IB-583

\*2: Only for IB-585



## 9. NBDP FILE OPERATIONS

2. Press the **1** key to select [New]. The title bar shows [UNTITLED 1] or [UNTITLED 2]. The cursor marks the location where you can type text.
3. Type your message.

**Note:** Do not use the lower case letters, or the symbols #, &, \*, \$ and % in telex messages. Also, do not put "\$\$\$" in the middle of a TX message, but at the end. The communication line is automatically disconnected when this string is detected.

To enter "\$\$\$" when editing a message, press the **Ctrl + Q** keys for IB-585. For IB-583, enter "\$\$\$" with using the **\$(4)** key.

## 9.3 How to Save a File

### **IB-583**

Use only 2HD type floppy disks. Insert the floppy disk with care. Rough handling can destroy the information stored inside. To eject the disk, press the **Eject** button on the left side of the floppy disk drive then remove the disk. Do not eject the disk while the operating lamp is lit, otherwise the contents of the disk can be damaged.

### **IB-585**

Use SD cards 2GB or below, or SDHC cards 32GB or below. Insert or eject the SD card with care when the power is off. Rough handling can destroy the information stored inside. When ejecting the SD card with power-on, execute [Remove SD Card] in the [File] menu (see "Function key F1: [File] menu" on page 7-4) then remove the SD card.

**Note:** When using the SD card after executing [Remove SD Card], remove the SD card then insert it.

### 9.3.1 How to format floppy disks or SD cards

Before you save a file to a floppy disk or an SD card, the disk or the card must be formatted. Format the disk or the card as below.

1. Press the function key **F1** to open the [File] menu.
2. Insert a new floppy disk or SD card in the drive.
3. Press the **0** key to select [Floppy Disk Format] or [SD Card Format].
4. Press the **↑** key to select [Yes] then press the **Enter** key. The screen shows formatting progress as below. After formatting has been completed, control is returned to the standby screen.

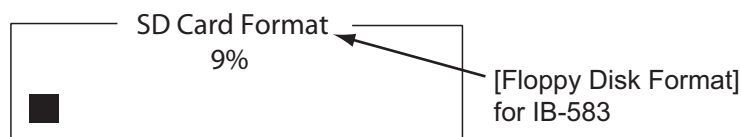

### 9.3.2 How to save a file

1. Press the function key **F1** to open the [File] menu.
2. Press the **3** key to select [Close]. The [Close Text] window appears.

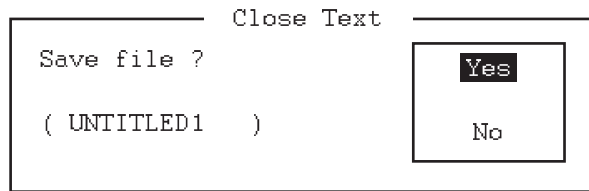

3. With [Yes] selected, press the **Enter** key.
4. Enter the file name, using up to eight characters. You can use any alphabet or numeric on the keyboard. You can not use the symbols shown below. You can add an extension at the end of the file name, for example, .TXT, to distinguish text files from macro files.

| ! : " > < ;

5. Press the **Enter** key.

## 9.4 How to Edit Files

### 9.4.1 How to cut and paste text

You can delete, move and copy text by using the [Cut], [Copy] and [Paste] functions in the [Edit] menu.

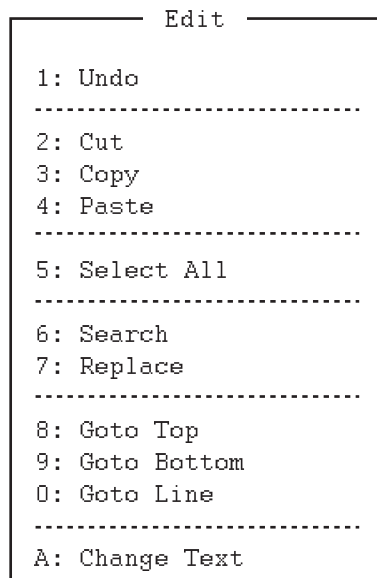

### How to cut text

1. Place the cursor on the first character of the text to cut.
2. Highlight the text to cut by pressing and holding the **Shift** key while pressing the → key. If you highlighted the text which you do not want to cut by mistake, press the ← key to adjust the highlight.

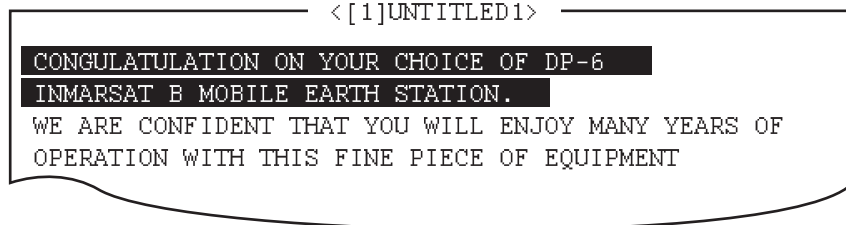

#### *The highlight*

3. Press the function key **F2** then the **2** key. Or press the **Del** key. The highlighted text is cut and the remaining text is reformatted.

If you made a mistake, you can restore the text. Select [Undo] in the [Edit] menu.

### How to paste text

To paste the cut text to a new location, do the following:

1. Place the cursor at the exact spot in the message where the cut text is to start.
2. Press the function key **F2** then the **4** key. Or press the **Ins** or **Insert** key.

## **9.4.2 How to copy and paste text**

You can copy a portion of text and paste it elsewhere.

1. Select the text to copy (see "How to cut text" on page 9-4).
2. Press the function key **F2** then the **3** key. The text selected is copied to the paste buffer memory where the cut or copied text is stored. The screen returns to the normal screen.
3. Place the cursor at the exact spot in the message where the copied text is to start.
4. Press the function key **F2** then the **4** key.

## **9.4.3 Select all**

The [Select All] feature lets you select all of the file currently displayed. This feature is useful when you want to combine the files. The procedure below explains how to place the file loaded in working area 1 onto the end of the file loaded in working area 2.

1. Load the file to copy from a floppy disk or an SD card in working area 1.
2. Press the function key **F2** then the **5** key. The entire file appears in reverse video.
3. Press the function key **F2** then the **3** key. The file is placed in the paste buffer memory.
4. Load the file to combine in working area 2.

- Place the cursor at the exact spot in the message where the text now in the paste buffer memory is to start then press the **Ins** or **Insert** key.

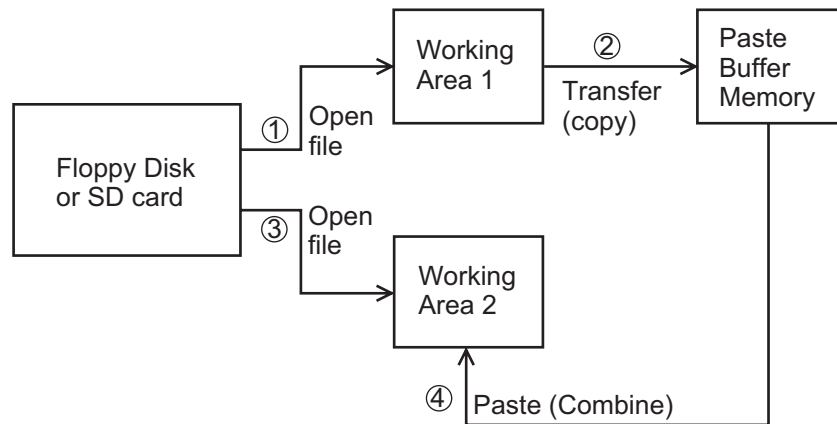

*Copy and paste flow diagram*

#### 9.4.4 How to search text

The [Search] feature lets you search for text in a forward or backward direction.

- Display a text and press the function key **F2** then the **6** key. The [Search] window appears.

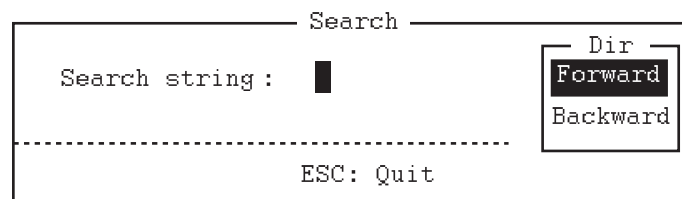

- Type the word to find.
- Press the → key.
- Press the ↑ or ↓ key to select [Forward] or [Backward] to search the file in a forward or backward direction respectively from the cursor position.
- Press the **Enter** key to begin the search.

When the unit finds the word, the cursor stops at the first character of the word. Press the **Enter** key to continue the search. If the string could not be found, the message "Not Found (To quit: ESC)" appears. Press the **Esc** key to quit.

#### 9.4.5 How to replace text

The [Replace] feature helps you to replace a word or phrase with another word or phrase in a file.

- Press the function key **F2** then the **7** key. The [Replace] window appears.

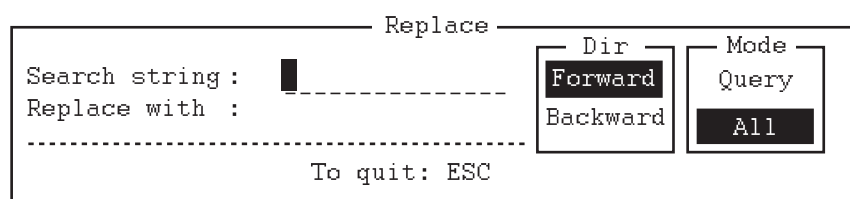

- Type a word to replace on the [Search string] line.

## 9. NBDP FILE OPERATIONS

3. Press the ↓ key to select [Replace with] then type a new word.
4. Press the → key.
5. Press the ↑ or ↓ key to select [Forward] or [Backward] to search the file in a forward or backward direction respectively from the cursor position.
6. Press the → key.
7. Press the ↑ or ↓ key to select whether you want to be queried or not each time the word is found.  
[Query]: Stop at each occurrence of the word to answer yes or no for replacement.  
[All]: Replace every occurrence of the word without confirmation.
8. Press the **Enter** key to start the replacement.

### 9.4.6 Goto line

The [Goto Line] feature places the cursor at the head of a line desired.

1. Press the function key **F2** then the **0** key. The [Goto Line] window appears.

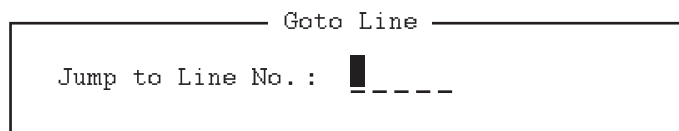

2. Key in a line number then press the **Enter** key. The cursor shifts to the head of the line selected.

### 9.4.7 Goto top, Goto bottom

You can easily go to the top or bottom line of a file. Press the function key **F2** then the **8** key to go to the top line; press the function key **F2** then the **9** key to go to the bottom line. Note that this feature can also be executed on the editor screen by pressing the **Home** or **End** key.

## 9.5 How to Open Files

Two working areas (called working area 1 and working area 2) are provided to which you can load a file, and one file can be displayed on the LCD.

### 9.5.1 Open a file

1. Insert the floppy disk or the SD card which contains the file to open.
2. Press the function key **F1** to open the [File] menu.

- Press the **2** key. A list of files on the floppy disk or the SD card appears.

```

Open Text
Load/Merge (TAB:Change)
[A:\TEST1. ]
-----File name-----Size---- Date & Time -----
LOG File           52    12-04-10 17:25
TEST1.             120   12-04-10 16:30
TEST2.             151   12-04-10  9:25
TEST3.             180   12-04-10 20:16
NBDP                169   12-04-10  6:23
[----- End of Directory -----]

4 Files exist                1454000 bytes free
-----
To select : ENTER  To view : SPACE  To quit : ESC

```

- Press the  $\uparrow$  or  $\downarrow$  key to select a file.
- Press the **Enter** key. The file appears and the title bar shows the file name. You can repeat this procedure to load another file into a working area.

**Note:** When two working areas have been opened, the close confirmation window appears. In this case, select [Yes] or [No] then press the **Enter** key to close an open file in order to open another file.

### 9.5.2 Switch between files

Two files can be opened and one file is displayed on the LCD. To switch between files, do the following:

- Press the function key **F2**.
- Press the **A** key to switch between the files.

## 9.6 How to Rename Files

To rename a file, do the following:

- Press the function key **F1**.
- Press the **5** key.
- Press the  $\uparrow$  or  $\downarrow$  key to select a file to rename then press the **Enter** key.
- Enter a new name.
- Press the **Enter** key.

## 9.7 How to Save a File Under a New Name

You can save a file under a new name as follows:

- Open a file.
- Edit the file as necessary.

3. Press the function key **F1**.
4. Press the **3** key to save the file.
5. Press the **Y** key.
6. Press the **Backspace** key to erase the original name then enter a new name.
7. Press the **Enter** key.

## 9.8 How to Delete Files

Insert the floppy disk or the SD card in the drive and do the following to delete unnecessary files.

1. Press the function key **F1**.
2. Press the **4** key.
3. Press the **↑** or **↓** key to select the file to delete then press the **Enter** key.
4. Press the **Enter** key again. (To cancel, press the **↓** key to select [NO] then the **Enter** key.)

## 9.9 Real Time Printing

An incoming or outgoing message can be printed out while it is being received or transmitted.

1. Press the function key **F1** to open the [File] menu.
2. Press the **6** key to turn real time printing on or off.

When the real time printing is on, "Print" appears in reverse video at the top of the screen. The sent messages are printed in bold face and the received messages are printed in normal type face.

## 9.10 How to Print Files

You can print files stored on the floppy disks or the SD cards as follows:

1. Press the function key **F1**.
2. Press the **7** key.
3. Press the **↑** or **↓** key to select a file then press the **Enter** key.
4. Press the **Y** key.

To stop printing at any time, press the function key **F1** then the **8** key. If the file could not be printed, the message "Cannot print. Check connection between printer and terminal. Press any key to escape." is displayed.

# 10. NBDP TRANSMISSION, RECEPTION

---

This chapter mainly shows you how to transmit and receive telex messages.

## 10.1 Manual Calling

### NOTICE

Before calling, watch the intended TX frequency carefully to confirm that is unoccupied.

The simplest way to communicate with a telex subscriber is manual calling. For the ARQ mode, you can display beforehand the message to send, or type your message manually.

1. Press the function key **F3** to open the [Operate] menu.

```
Operate
-----
1: Call Station
2: Macro Operation
-----
3: File to Send
4: Cancel Sending
-----
5: Scan (Start/Stop)
-----
6: Manual Reception
-----
7: Timer Operation
-----
8: Manual Calling
9: Set Frequency
```

For IB-583

```
Operate
-----
1: Call Station
2: Macro Operation
-----
3: File to Send
4: Cancel Sending
-----
5: Scan (Start/Stop)
-----
6: Manual Reception
-----
7: Timer Operation
-----
8: Manual Calling
9: Set Frequency
0: Set Channel
```

For IB-585

2. For IB-583:  
Press the **9** key to select [Set Frequency].

```
Set Frequency
-----
Tx Freq: 0.00
RX Freq: 0.00
```