

Pub. No.: SB-2240

Date : November 1, 2002

November 1, 2002

All data herein contained is true and correct to my best knowledge.

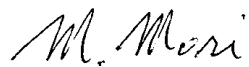

Masayuki Mori

Manager

Radio Communication Engineering Section,
Research and Development Department,
Marine Electronic Products Division

FURUNO ELECTRIC CO., LTD.

***** CONTENTS *****

1	GENERAL INFORMATION.....	3
1.1	Specifications.....	3
1.2	List of Test Equipment Used.....	4
2	IDENTIFICATION OF EQUIPMENT (FCC Rule Part 2.925).....	6
3	TEST DATA	7
3.1	RF POWER OUTPUT (FCC Rules Part 80.215 & 2.1046).....	7
3.2	MODULATION CHARACTERISTICS (FCC Rule Part 2.1047).....	10
3.2.1	Audio Frequency Response (FCC Rules Part 2.1047 (a) & 80.213)	10
3.2.2	Power Limiting vs. Audio Input Voltage (FCC Rule Part 2.1047).....	12
3.3	OCCUPIED BANDWIDTH (FCC Rule Part 2.1049).....	14
3.4	EMISSION LIMITATIONS (FCC Rule Part 80.211).....	26
3.5	SPURIOUS EMISSIONS AT ANTENNA TERMINAL (FCC Rule Part 2.1051)	27
3.6	FIELD STRENGTH OF SPURIOUS RADIATION (FCC Rule Part 2.1053).....	40
3.7	FREQUENCY STABILITY (FCC Rule Part 2.1055).....	46
3.8	SUPPRESSION OF INTERFERENCE FROM RECEIVER (FCC Rules Part 80.217 and 2.1051).....	54
4	TRANSMITTER POWER ADJUSTMENT PROCEDURE (FCC Rule part 2.1033).....	55
5	PHOTOGRAPHS TO REVEAL EQUIPMENT CONSTRUCTION AND LAYOUT (FCC Rule Part 2.1033)	56
6	DESCRIPTION OF CIRCUITRY AND DEVICES (FCC Rule Part 2.1033)	57
6.1	Function of Each Semiconductor or Active Device	57
6.2	Description of the circuits employed for suppression of spurious radiation, for limiting or shaping the control pulse, and for limiting or controlling power	65
7	Operator ' s Manual incl. Circuit Diagrams (FCC Rule Part 2.1033).....	66

1 GENERAL INFORMATION

1.1 Specifications

- (a) Manufacturer: Furuno Electric Co., Ltd.,
Aihara-cho 9-52, Nishinomiya-city,
662-8580 Japan
- (b) Model: FS- 1570
(Serial No.: 3535-0002)
- (c) Frequency Range: 1.6 to 27.5 MHz (transmit)
0.1 to 29.9 MHz (receive)
- (d) Class of Emission: J3E (LSB/USB, Telephony)
H3E (receive only)
F1B,
J2B (DSC, NBDP)
F3C (receive only)
- (e) RF Output Power: 150 W
- (e) Power Supply: 24 V DC
0.8 A (receive)
20 A (max) (transmit)
- (f) Dimensions & Weight:
- (1) Transceiver unit (FS-1570T),
440 mm (H) x 340 mm (W) x 135 mm (D)
11.0 kg
 - (2) Antenna Coupler (AT-1560-15),
390 mm (H) x 267 mm (W) x 90 mm (D)
8.7 kg
 - (3) Control unit (FS-2570C)
121 mm (H) x 300 mm (W) x 110 mm (D)
1.8 kg
 - (4) Handset (HS-2001),
200 mm (H) x 55 mm (W) x 77 mm (D)
0.6 kg

1.2 List of Test Equipment Used

(a) SPECTRUM ANALYZER

Manufacturer: Takeda Riken
Model: TR 4173
S/No: 85580030

(b) 50 Ω LOAD/ WATT METER:

Manufacturer: Tokyo Denpa
Model: DJ 522-OH-2
DC to 30 MHz: 50 250/500 W
S/No: 46507

(c) DC POWER SUPPLY

Manufacturer: Takasago
Model: GP 035-50R
0 to 35 VDC, 0 to 50 A
S/No: 13086029

(d) PLOTTER

Manufacturer: EPSON
Model: HI-80
S/No: 02006569

(e) BROADBAND ROD ANTENNA

Manufacturer: AILTECH
Model: 95010-1
10 kHz to 40 MHz
S/No: 496

(f) BICONICAL ANTENNA

Manufacturer: ELECTRO METRICS
Model: BIA-25
20 MHz to 220 MHz
S/No: 2650

(g) FREQUENCY COUNTER:

Manufacturer: TAKEDA RIKEN
Model: TR5824
10 Hz to 600 MHz: 5×10^{-8} /day
S/NO: 41930036

(h) AUDIO SIGNAL GEN (2 ea.):

Manufacturer: KENWOOD
Model: AG-253
50 Hz to 1 00 MHz, 600
S/No: 1100026 & 709003

(i) AUDIO VOLT METER:

Manufacturer: Kikusui Electronics Corp.:
Model: 161E
S/No: 2961776

Pub. No.: SB-2240

Date : November 1, 2002

(j) OSCILLOSCOPE:

Manufacturer:	SONY TEKTRONIX
Model:	2445
S/No:	B02576

(k) STORAGE OSCILLOSCOPE:

Manufacturer:	TEKTRONIX
Model:	2330
S/No:	300462

(L) MODULATION ANALYZER:

Manufacturer:	HEWLETT PACKERD
Model:	8901B
S/No:	2718A01184

2 IDENTIFICATION OF EQUIPMENT (FCC Rule Part 2.925)

The following nameplates are permanently fixed on the equipment.

FCC ID: ADB9ZWFS1570
Material of nameplate: Polyester film t 188 μm

ON TRANSCEIVER UNIT:

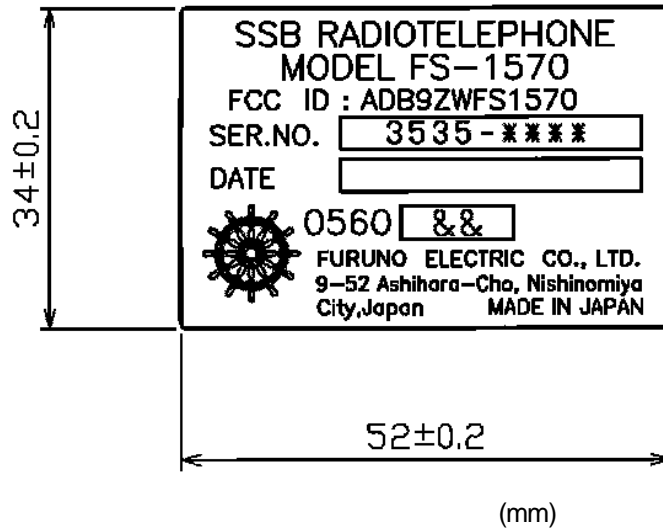

ON ANTENNA COUPLER UNIT:



3 TEST DATA

3.1 RF POWER OUTPUT (FCC Rules Part 80.215 & 2.1046)

3.1.1 Method of Measurement

The FS-1570 is connected with measuring equipment as shown in Fig. 3.1.1.

Supply voltage is set to 24 VDC. An ammeter is connected in series with collector of each final stage transistor. Test is made under normal environmental condition.

2 Audio Signal Generators generating each 400 Hz and 1800 Hz at an equal level are adjusted to produce transmitter RF output power 150 Wpep. Collector current is then measured.

Measurement is made on every test frequency on class of emission J3E.

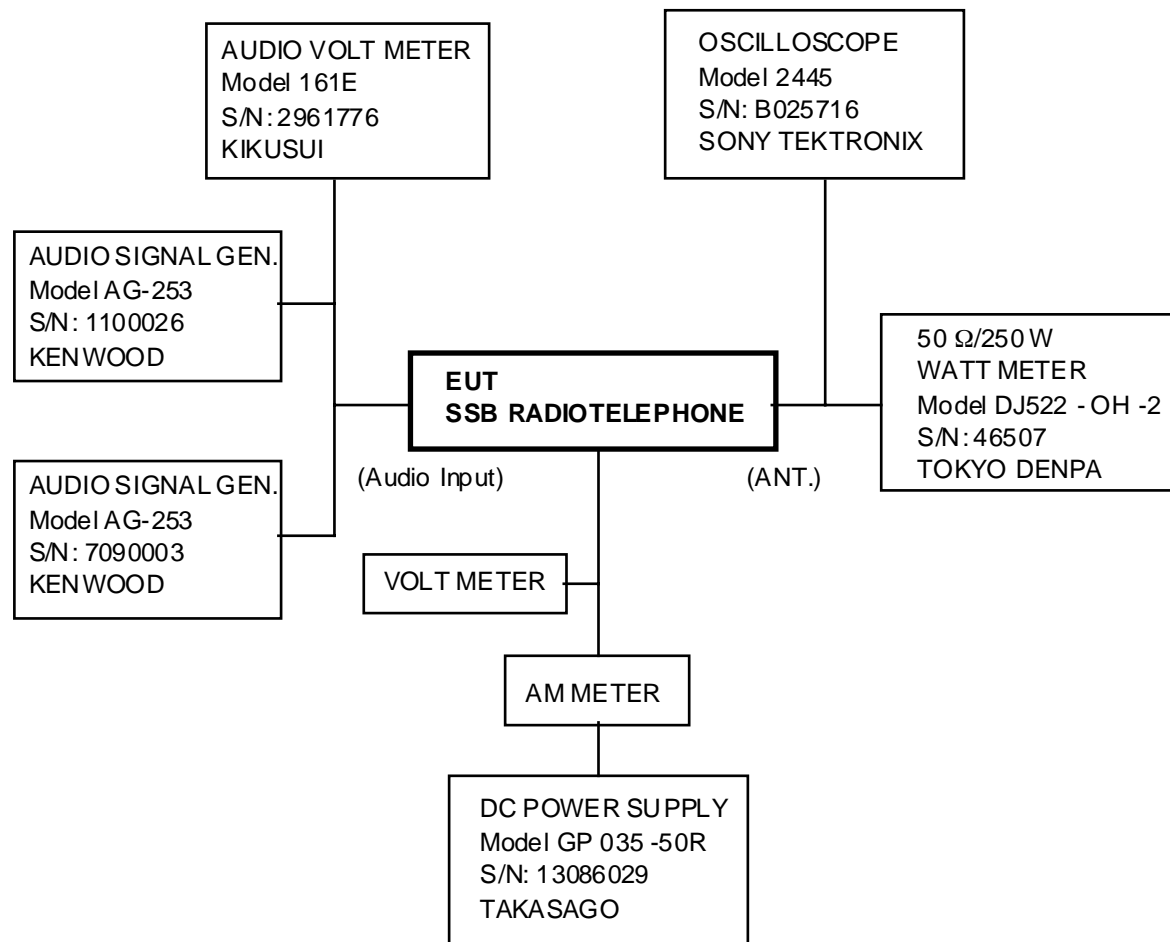

Fig. 3.1.1

3.1.2 Test Result

Results are shown in Table 3.1.1

Table 3.1.1

Frequency (kHz)	Class of Emission	Supply Voltage (VDC)	Collector Current (A)	PEP (W)
1605.0	J3E	24	8.5	150
2182.0	J3E	24	7.1	150
3023.0	J3E	24	7.1	150
4065.0	J3E	24	8.9	150
6200.0	J3E	24	7.5	145
8195.0	J3E	24	8.0	145
12230.0	J3E	24	7.5	140
16360.0	J3E	24	7.0	140
18780.0	J3E	24	7.0	140
22000.0	J3E	24	7.0	140
25070.0	J3E	24	7.0	130

Power is calculated by doubling the readout of Wattmeter showing average power as explained in paragraph 3.1.3 below.

3.1.3 Relation between Average Power and Peak Envelope Power

3.1.3.1 CW (Single Tone):

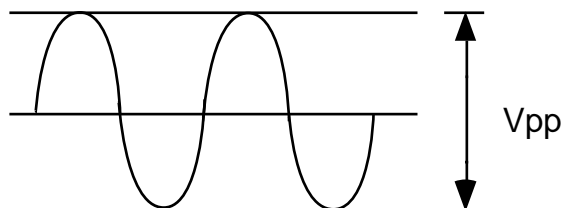

$$\text{Average power: } P_a = \frac{(V_{pp}/2)^2}{R_L} = \frac{V_{pp}^2}{8 R_L}$$

$$\text{PEP: } P_p = \frac{(V_{pp}/2)^2}{R_L} = \frac{V_{pp}^2}{8 R_L}$$

Therefore; $P_a = P_p$

3.1.3.2 AM:

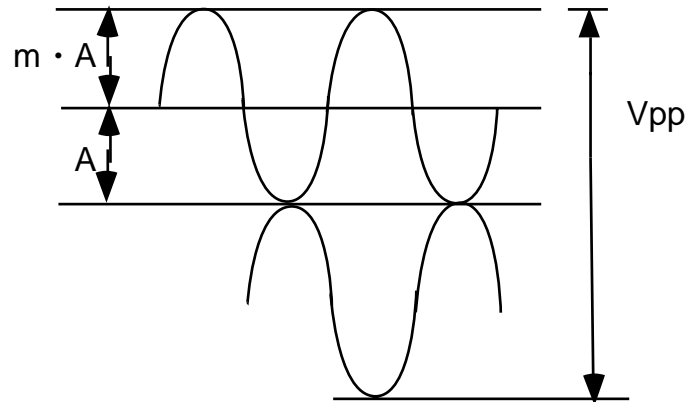

$$\text{Average power: } P_a = \left(1 + \frac{m^2}{2}\right) \cdot P_c$$

where, P_c : carrier power, m : depth of modulation.

$$\text{While, } P_c = \frac{(A/2)^2}{R_L} = \frac{A^2}{2R_L}$$

$$\text{and, } V_{pp} = 2(1+m) \cdot A$$

$$\text{Therefore, } P_c = \frac{1}{2R_L} \cdot \left(\frac{V_{pp}}{2(1+m)}\right)^2 = \frac{V_{pp}^2}{8(1+m)^2 \cdot R_L}$$

$$\text{Therefore, } P_a = \left(1 + \frac{m^2}{2}\right) \cdot \frac{V_{pp}^2}{8(1+m)^2 \cdot R_L}$$

$$\text{PEP: } P_p = \frac{(V_{pp}/2)^2}{R_L} = \frac{V_{pp}^2}{8R_L}$$

$$\text{Therefore, } P_a = \left(1 + \frac{m^2}{2}\right) \cdot \frac{P_p}{(1+m)^2}$$

$$\text{or, } P_p = \frac{(1+m)^2}{1+m^2/2} \cdot P_a$$

- $m = 1$: $P_p = 2.67 P_a$
- $m = 0.8$: $P_p = 2.47 P_a$
- $m = 0.5$: $P_p = 2.1 P_a$

3.2 MODULATION CHARACTERISTICS (FCC Rule Part 2.1047)

3.2.1 Audio Frequency Response (FCC Rules Part 2.1047 (a) & 80.213)

3.2.1.1 Method of Measurement

The FS-1570 is connected with measuring equipment as shown in Fig. 3.2.1.1.

A single audio tone is applied to the transmitter and varied over the range 100 to 5000 Hz. Output power is measured for variation of audio frequency with the output level 30 W referred to as 0 dB.

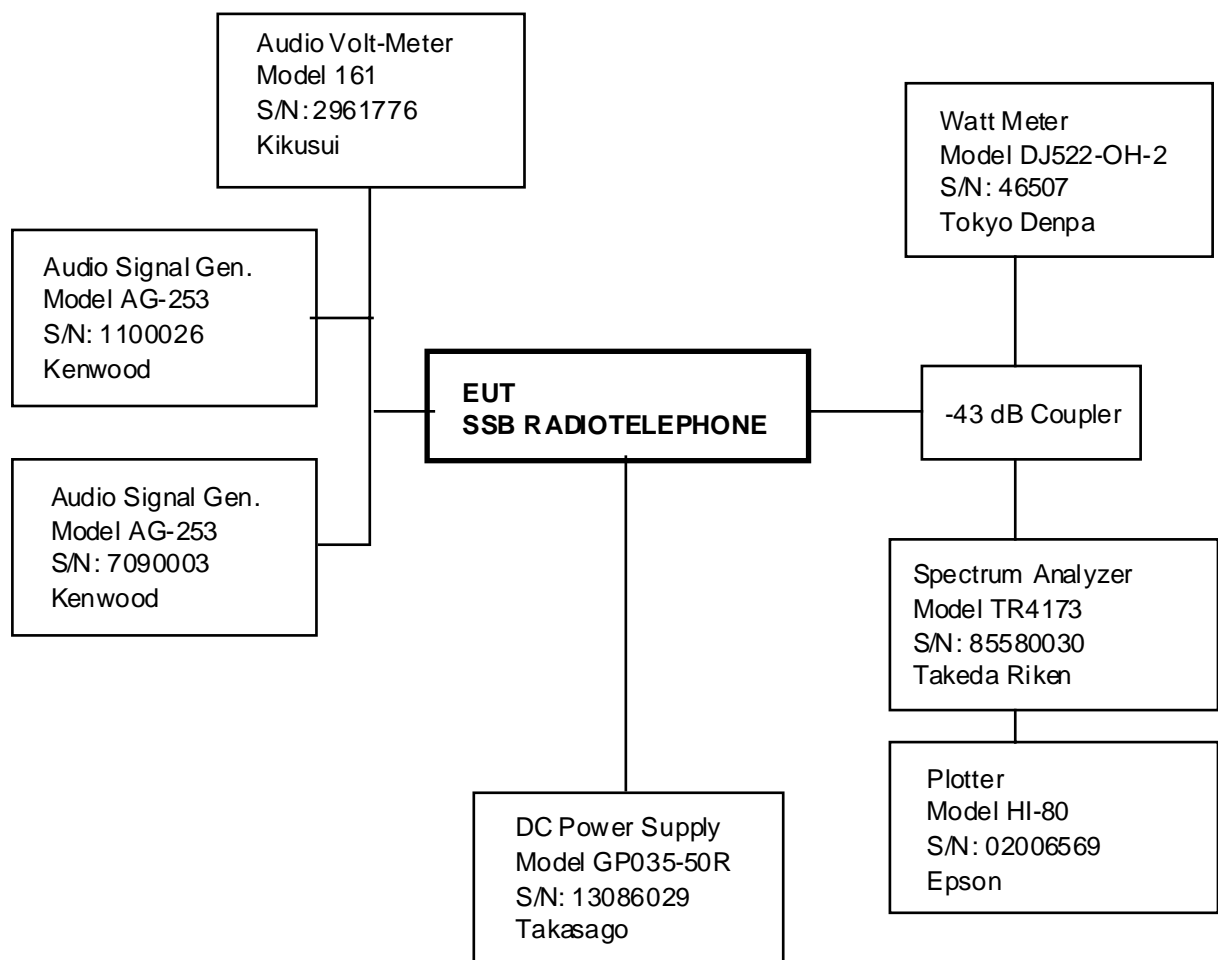

Fig. 3.2.1.1

3.2.1.2 Test Result

1. Output level for respective audio frequency is plotted in Fig. 3.2.1.2.
2. Carrier levels on each mode are as in Table 3.2.1.

Table 3.2.1

Class of emission	mode	below pep	Limit
J3E	Suppressed Carrier mode	55 dB	at least 40 dB

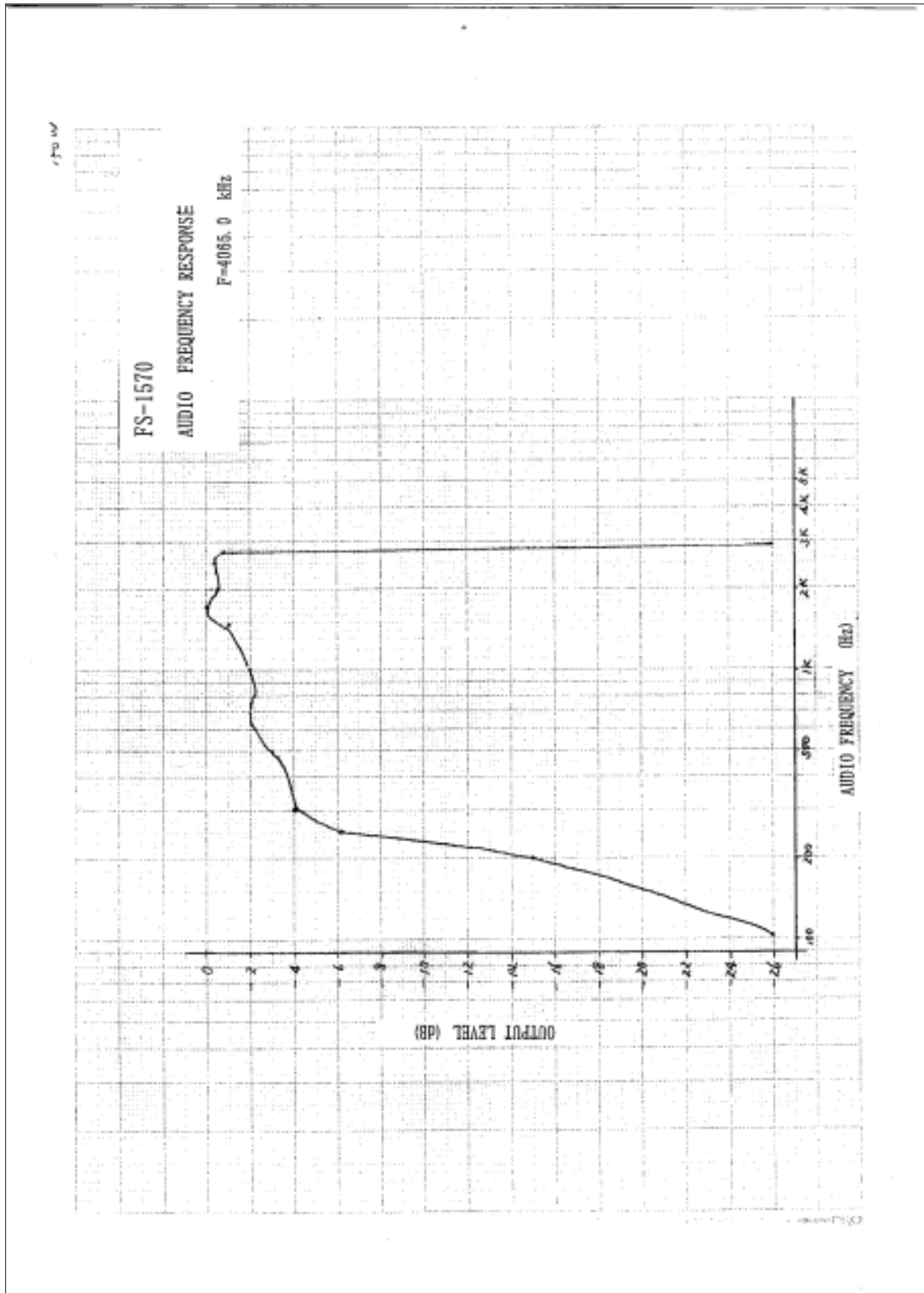

Fig. 3.2.1.2 Audio Frequency Response

3.2.2 Power Limiting vs. Audio Input Voltage (FCC Rule Part 2.1047)

3.2.2.1 Method of Measurement

The FS-1570 is connected with measuring equipment as shown in Fig. 3.2.2.1.

2 audio tones of 400 Hz and 1800 Hz are applied to the transmitter in equal level. The input level is varied and PEP is measured.

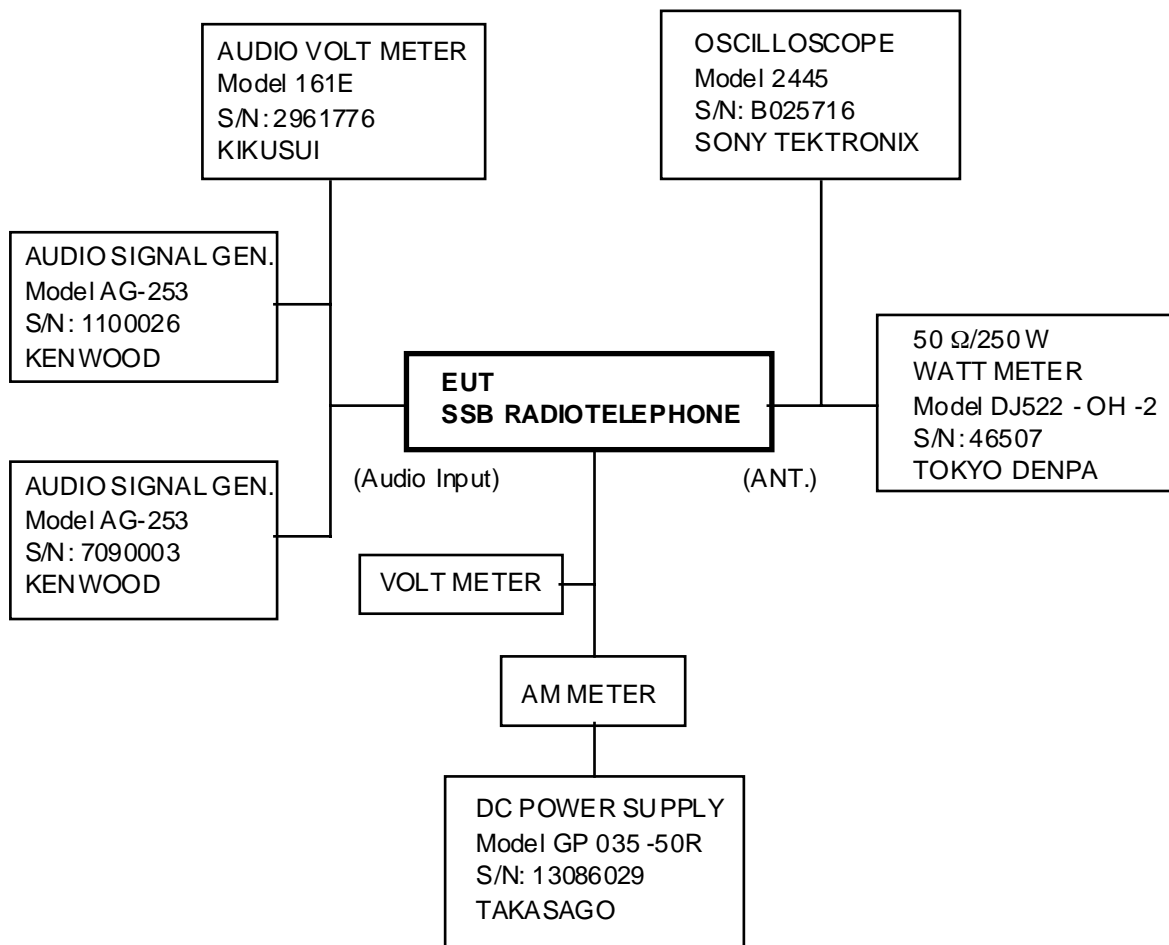

Fig. 3.2.2.1

3.2.2.2 Test Result

Measurement is made on frequency 4065 kHz. The results are shown in Fig. 3.2.2.2.

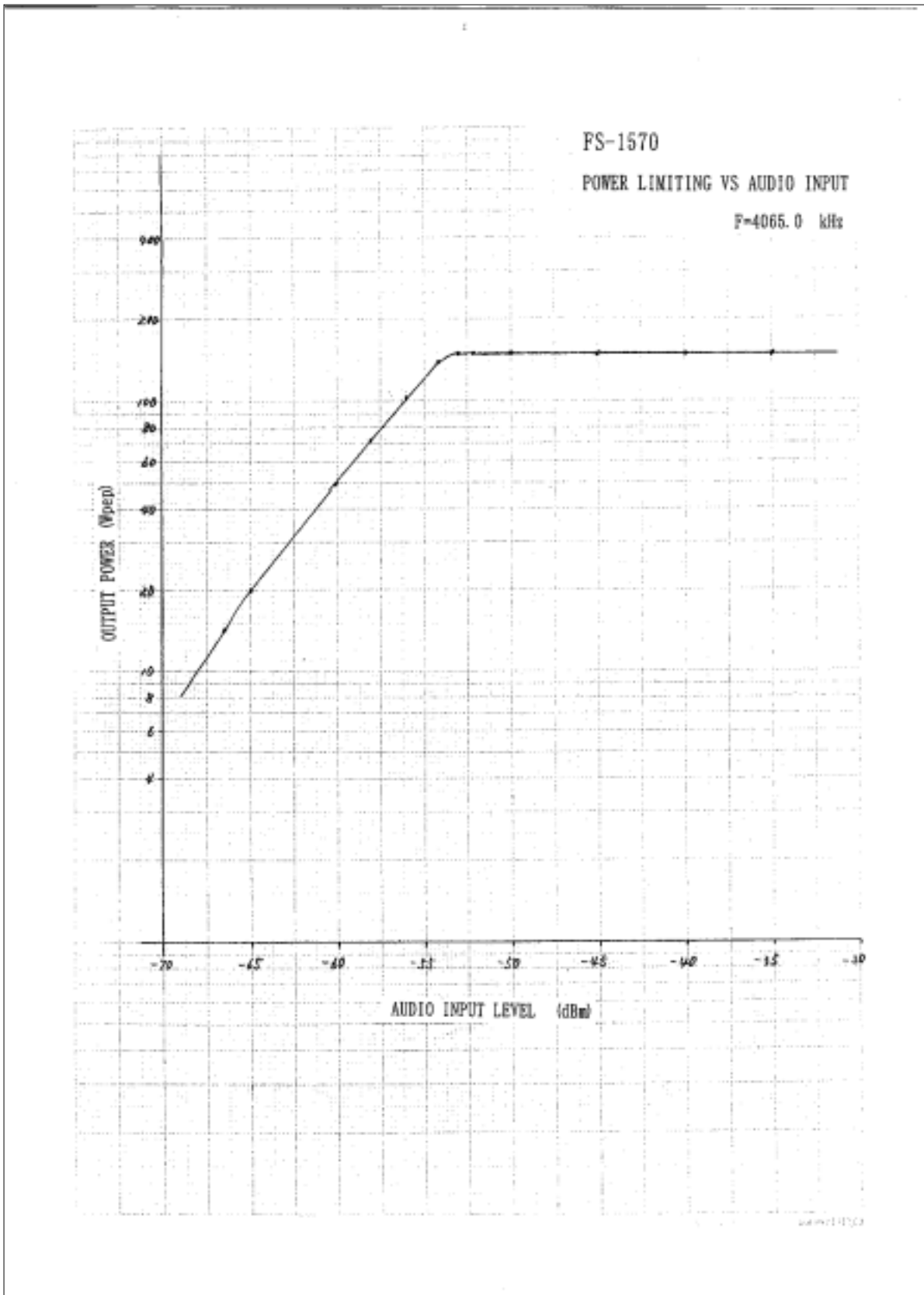

Fig. 3.2.2.2 Power Limiting vs. Audio Input Voltage

3.3 OCCUPIED BANDWIDTH (FCC Rule Part 2.1049)

3.3.1 Method of Measurement

The FS-1570 is connected with measuring equipment as shown in Fig. 3.3.1.

2 audio tones of 400 Hz and 1800 Hz are applied, in equal level, to the transmitter. The level is adjusted to 10 dB above the level producing PEP output of 150 W for test frequencies 4 MHz or below.

The output is monitored with Spectrum Analyzer with settings of span 50 kHz, IF bandwidth (resolution bandwidth) 300 Hz and video bandwidth 300 Hz.

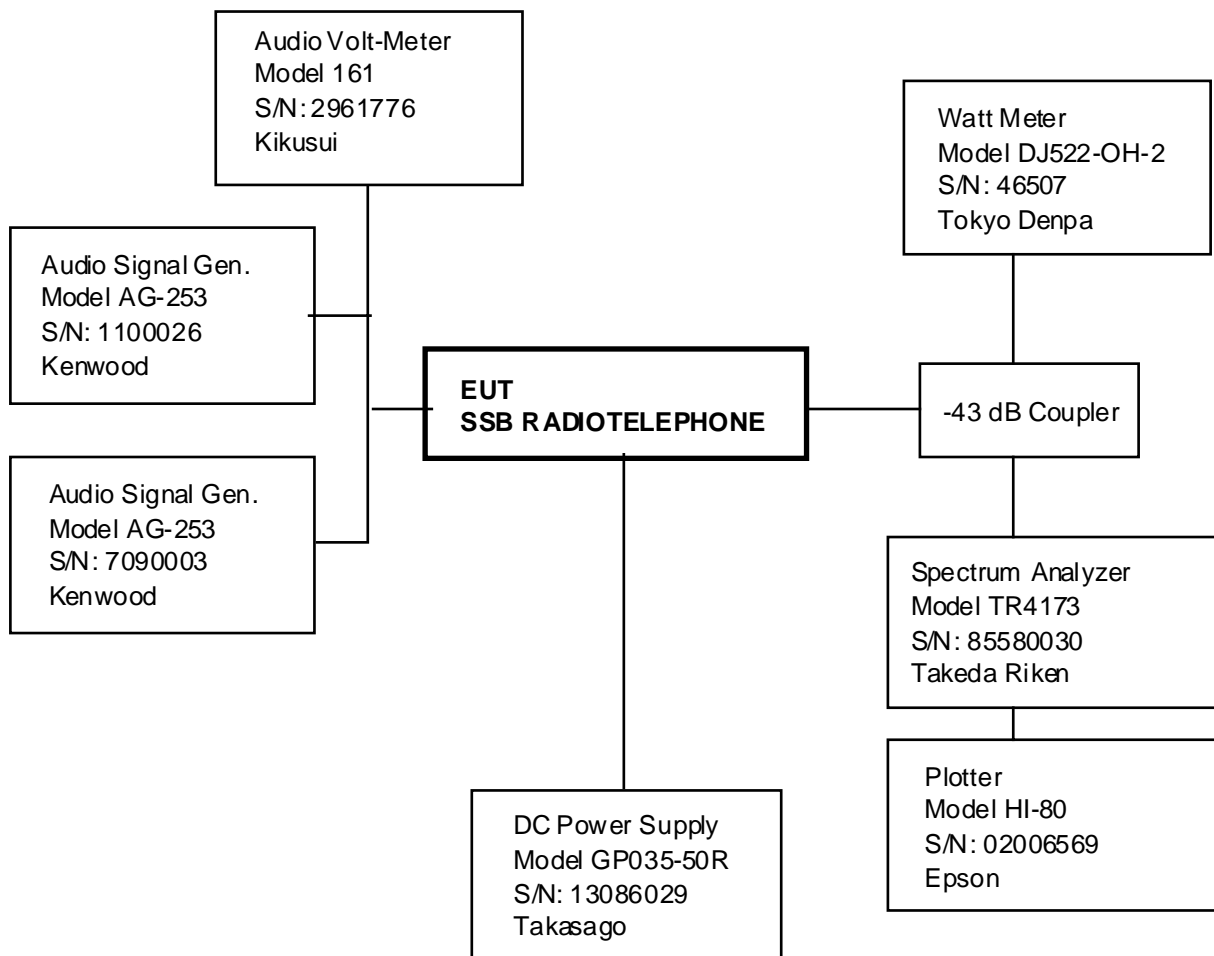

Fig. 3.3.1

3.3.2 Test Result

Results are shown in Fig. 3.3.2 to 3.3.12 for J3E (USB) and Fig. 3.3.13 to 3.3.22 for F1B, J2B. Occupied bandwidth is a bandwidth in which 99 % of the mean power radiated falls.

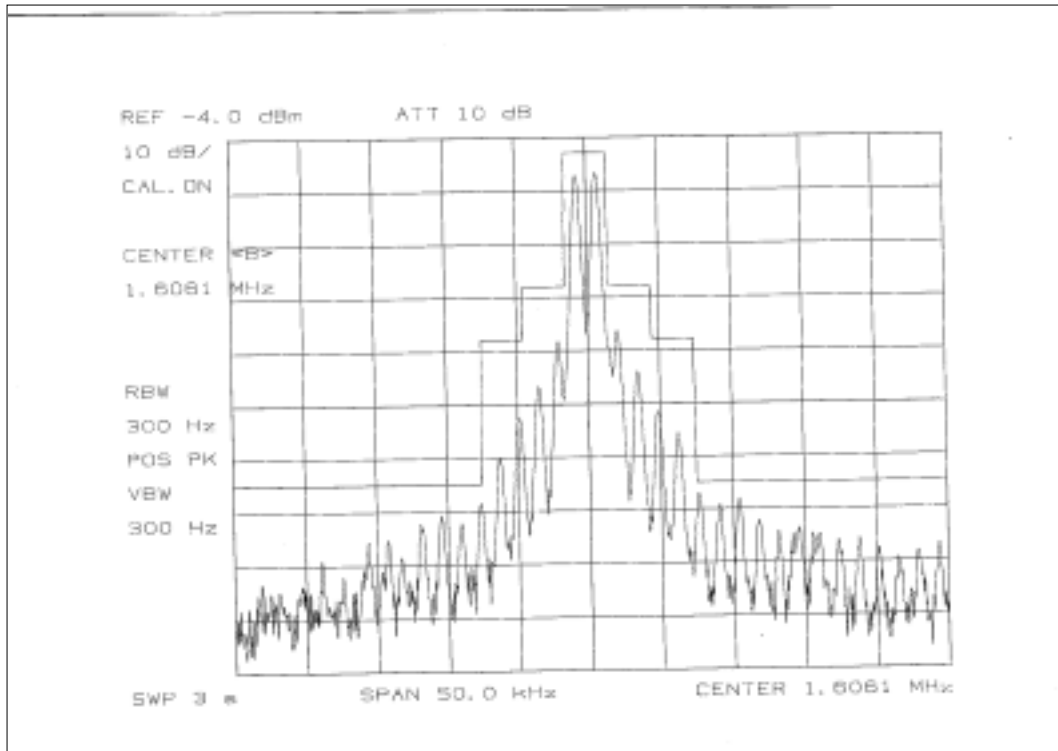

Fig. 3.3.2 - (Fc: 1.6 MHz, J3E)

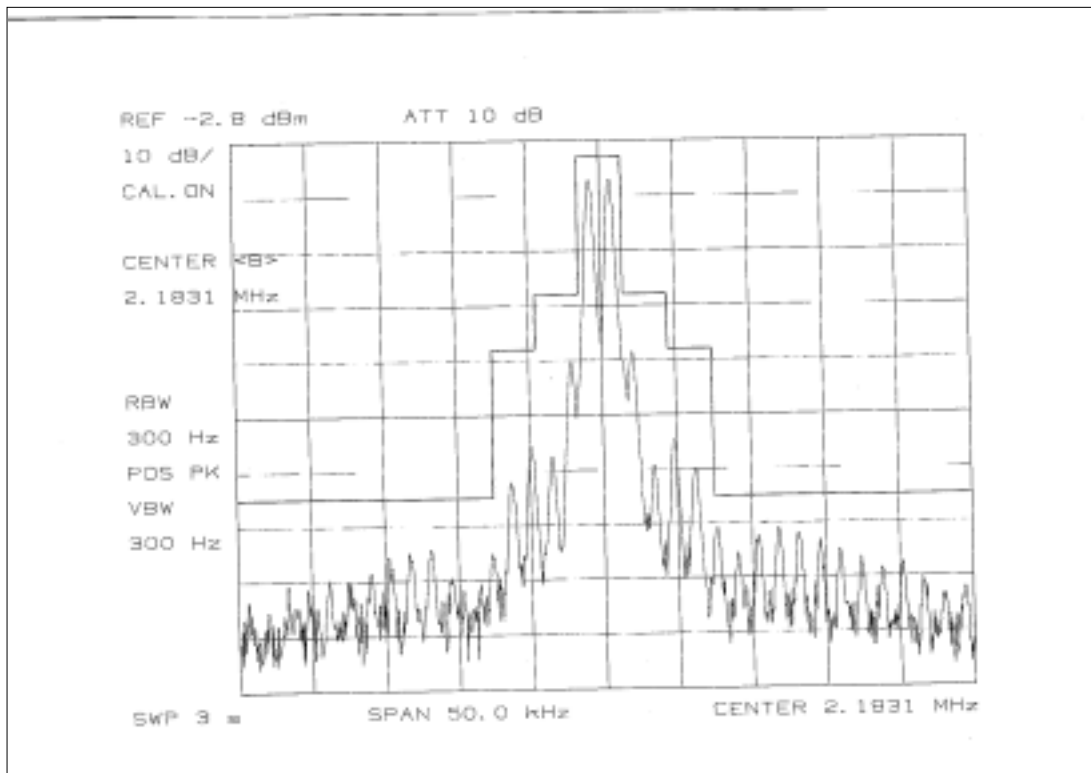

Fig. 3.3.3 - (Fc: 2 MHz, J3E)

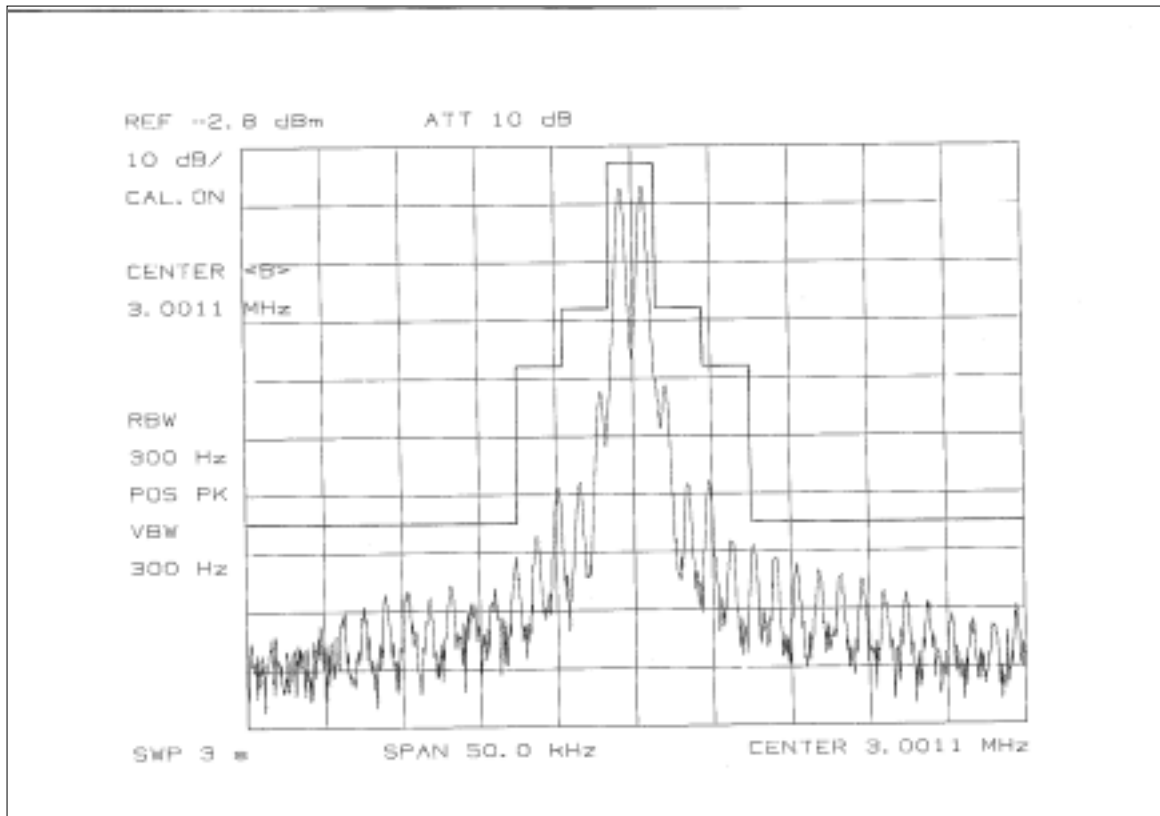

Fig. 3.3.4 - (Fc: 3 MHz, J3E)

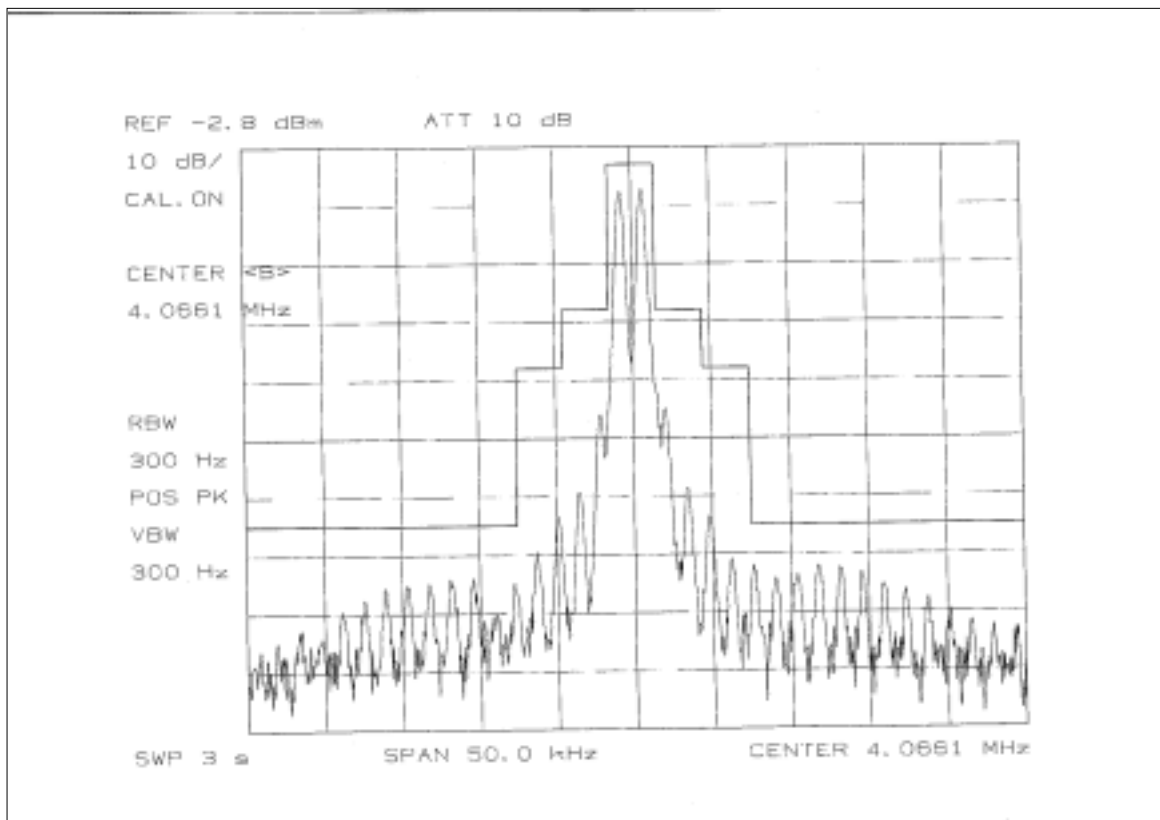

Fig. 3.3.5 - (Fc: 4 MHz, J3E)

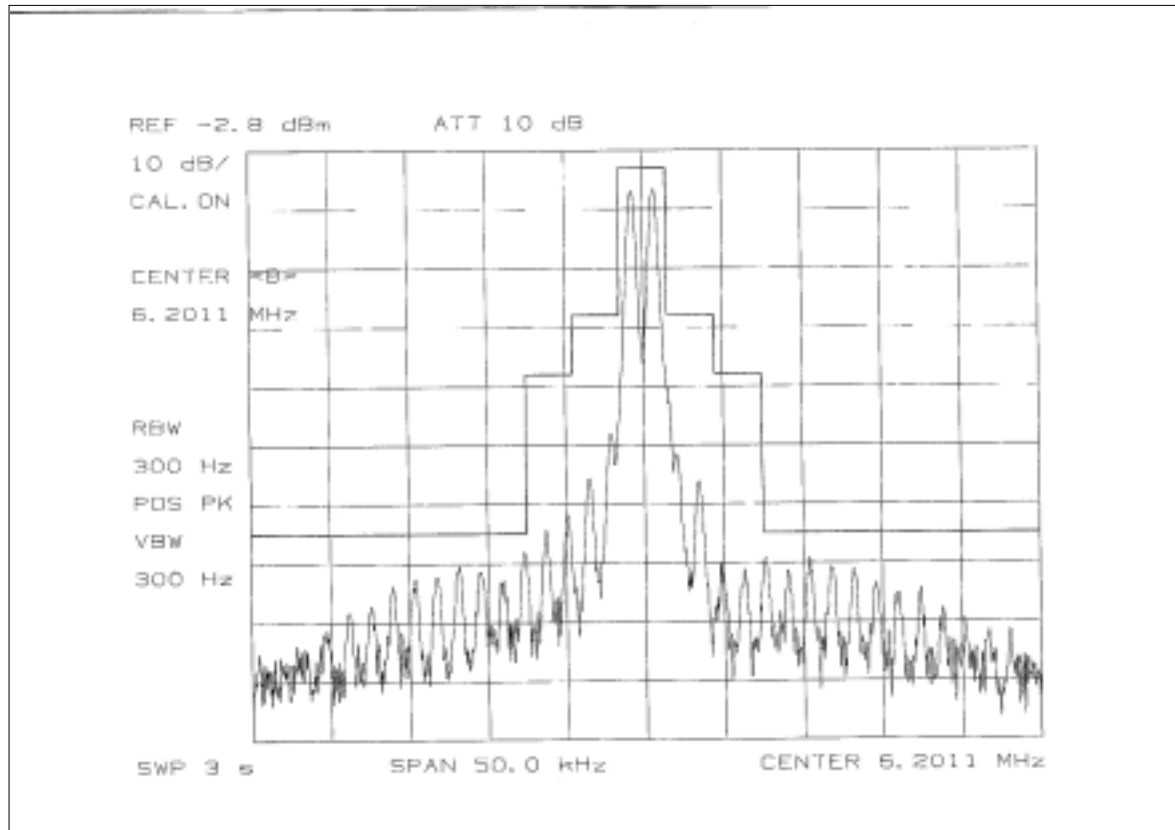

Fig. 3.3.6 - (Fc: 6 MHz, J3E)

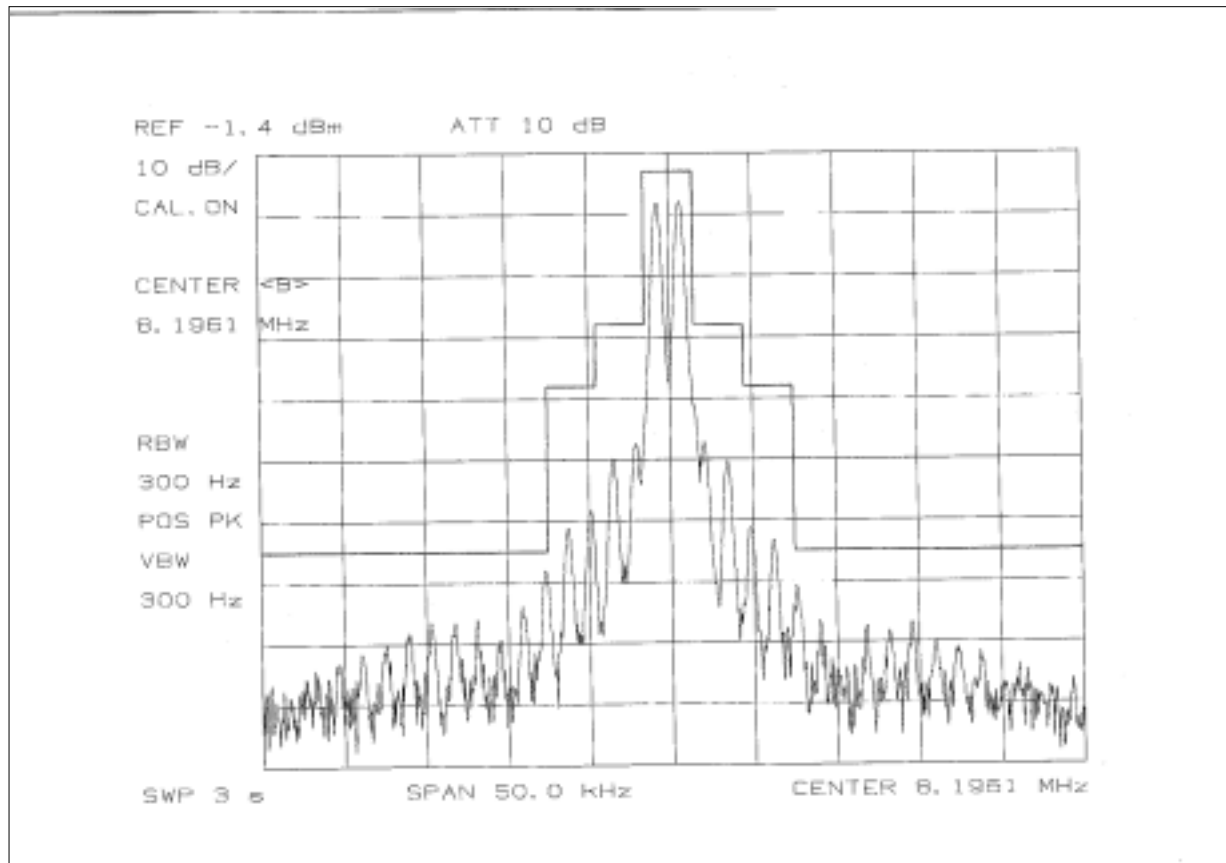

Fig. 3.3.7 - (Fc: 8 MHz, J3E)

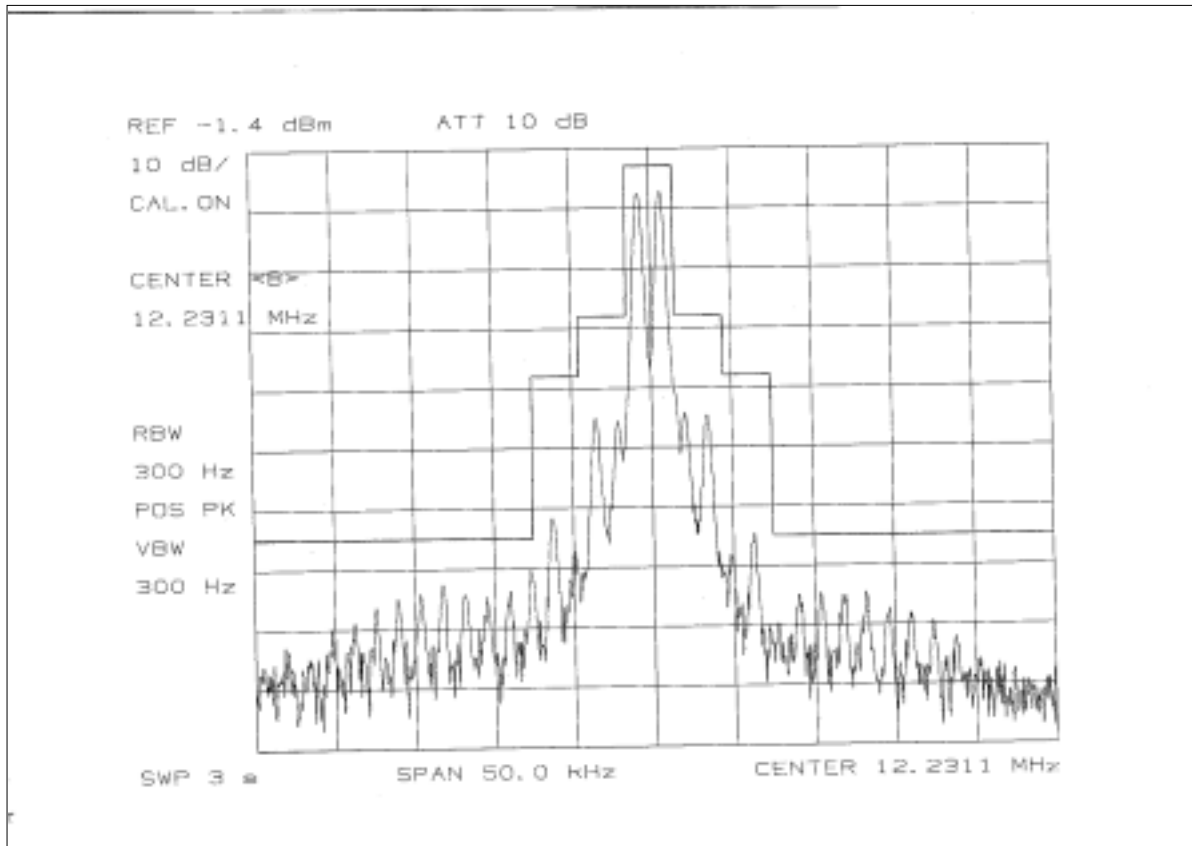

Fig. 3.3.8 - (Fc: 12 MHz, J3E)

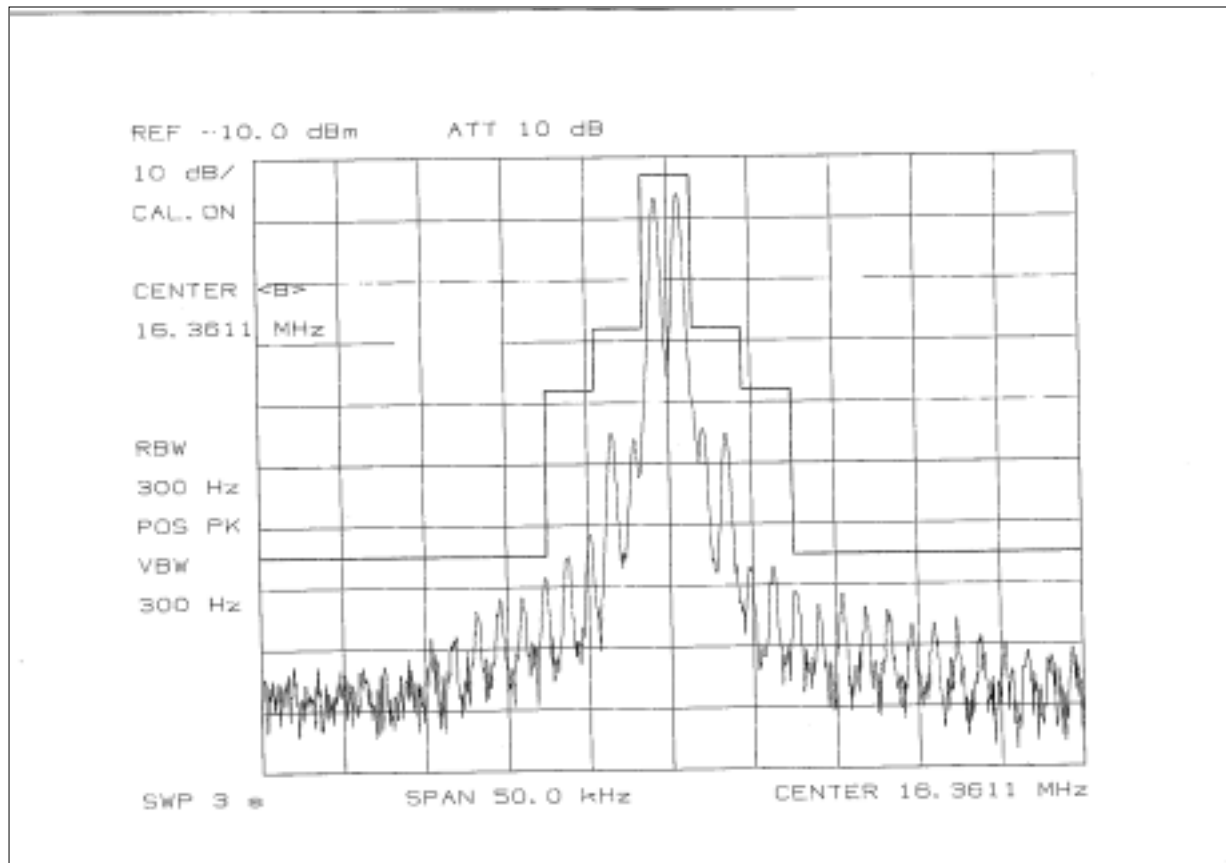

Fig. 3.3.9 - (Fc: 16 MHz, J3E)

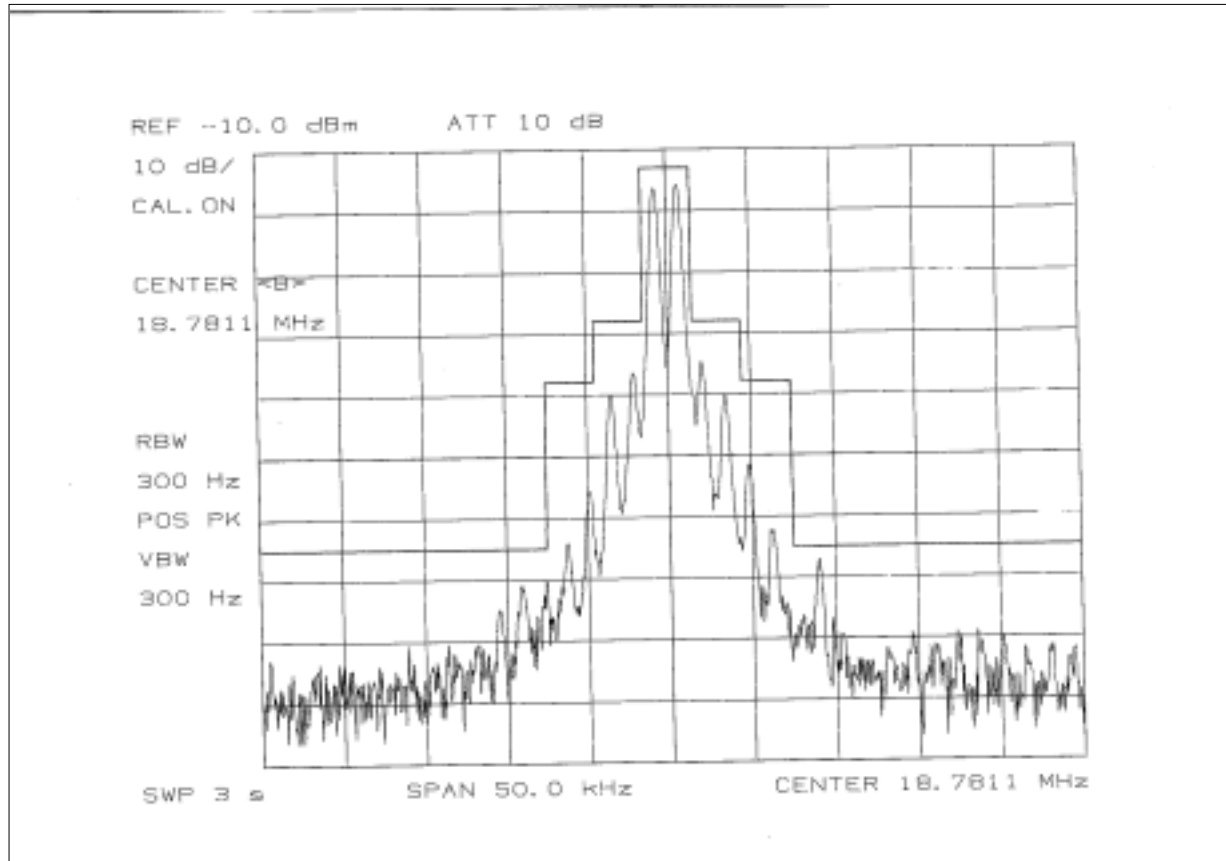

Fig. 3.3.10 - (Fc: 18 MHz, J3E)

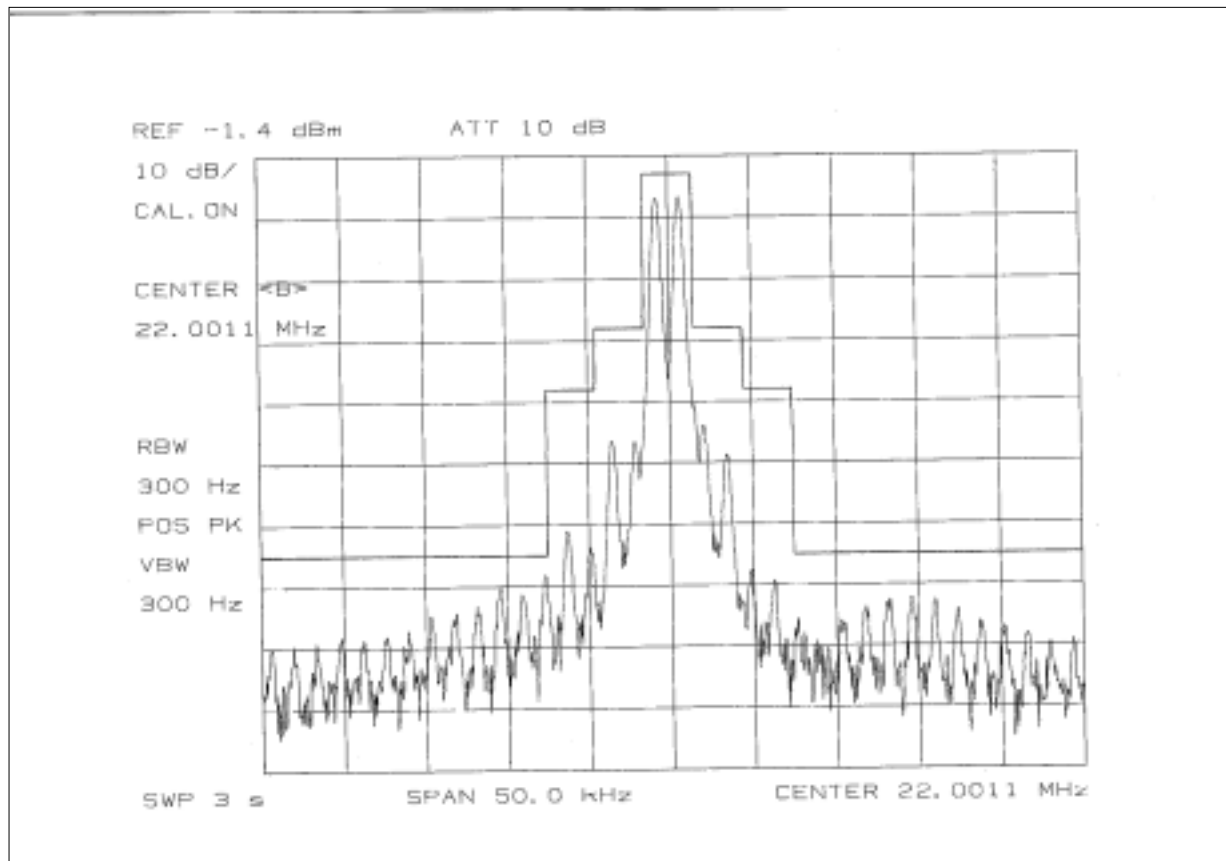

Fig. 3.3.11 - (Fc: 22 MHz, J3E)

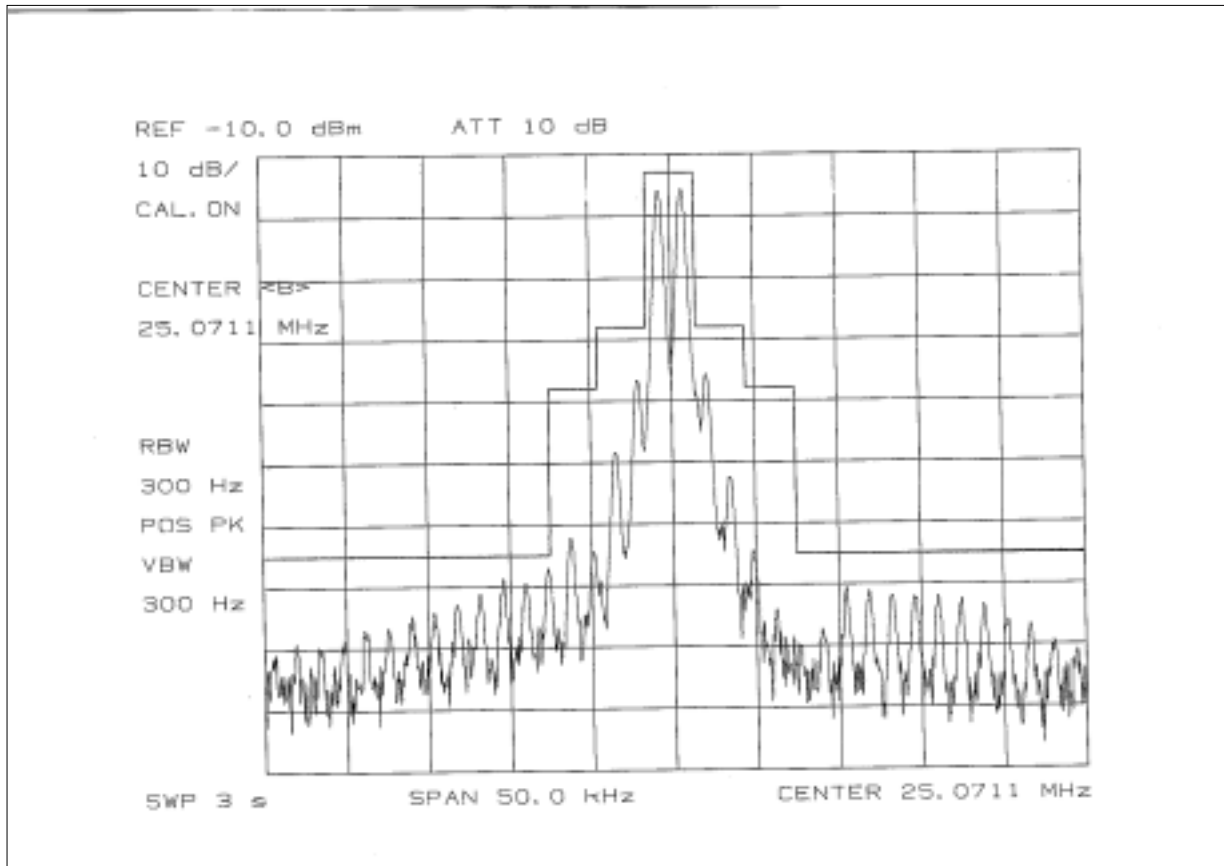

Fig. 3.3.12 - (Fc: 25 MHz, J3E)

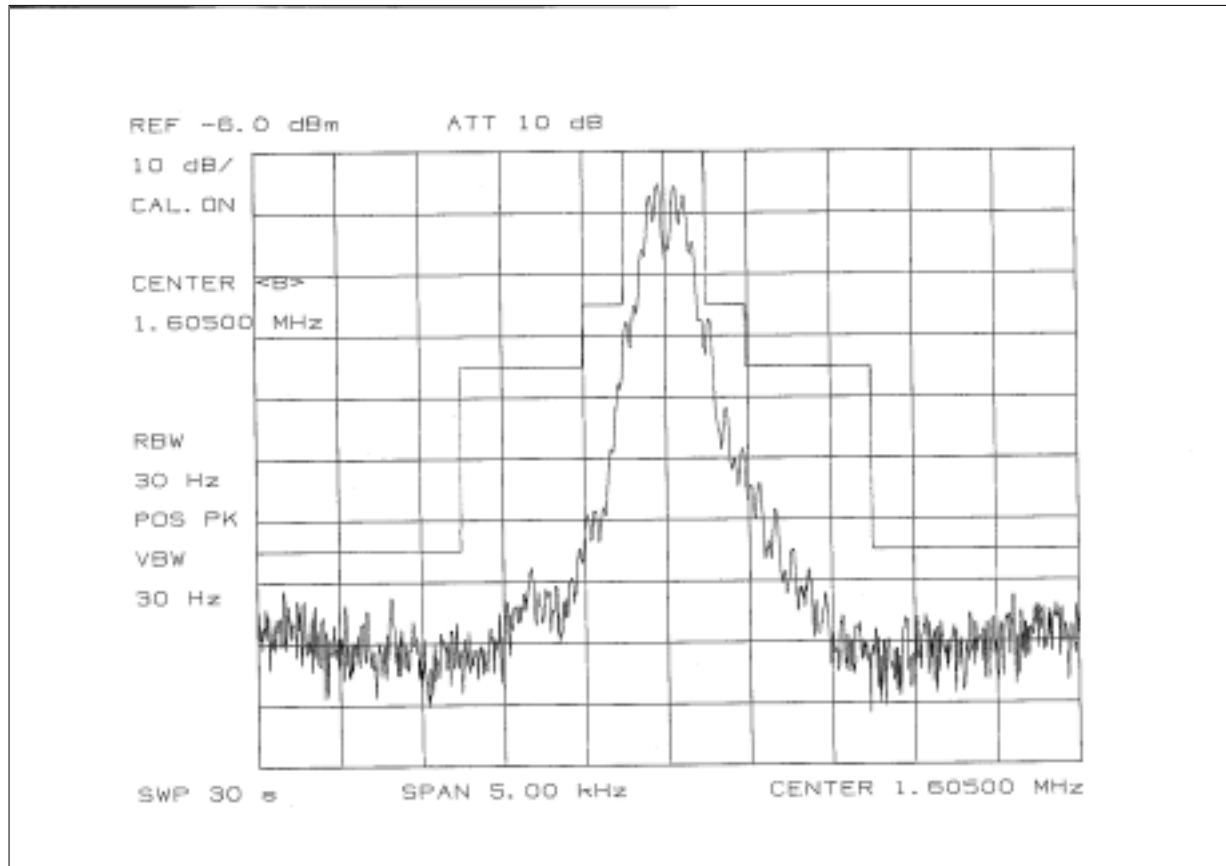

Fig. 3.3.13 - (Fc: 1.6 MHz, F1B/J2B)

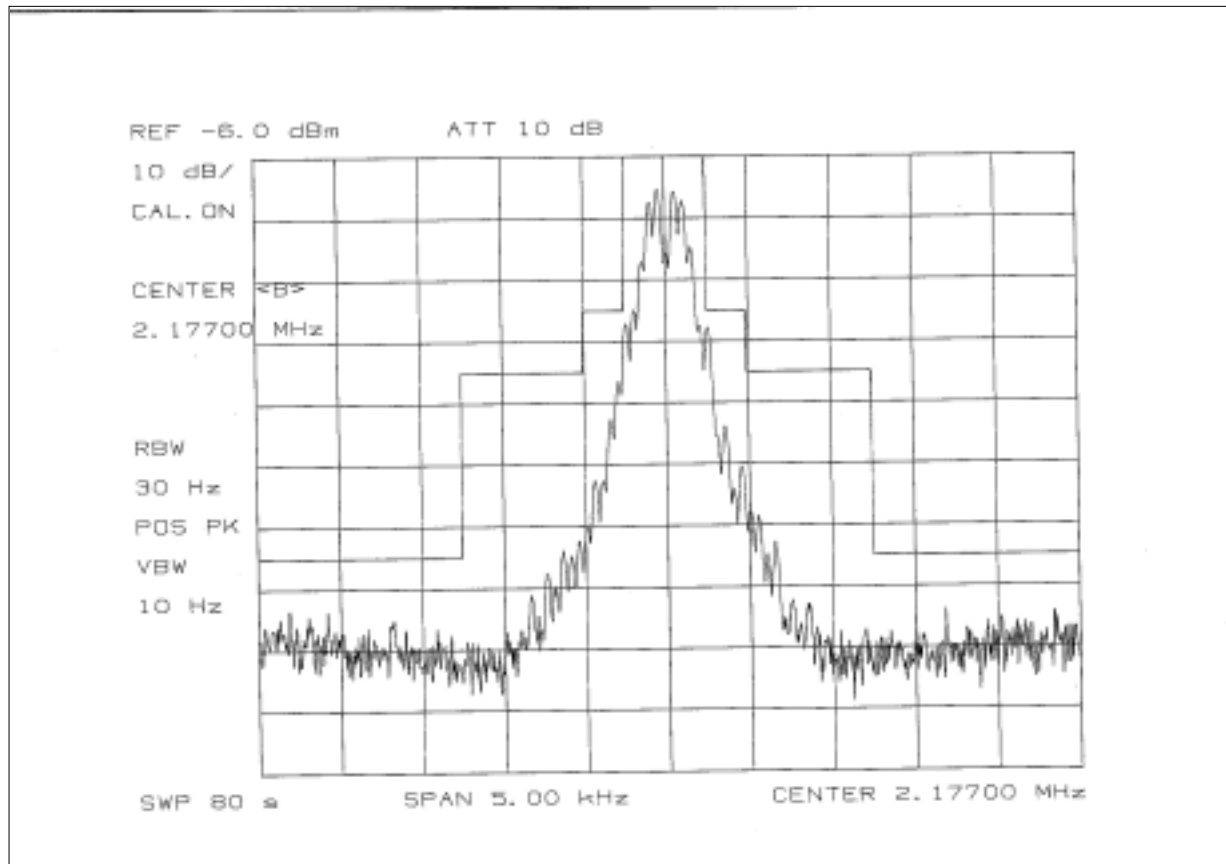

Fig. 3.3.14 - (Fc: 2 MHz, F1B/J2B)

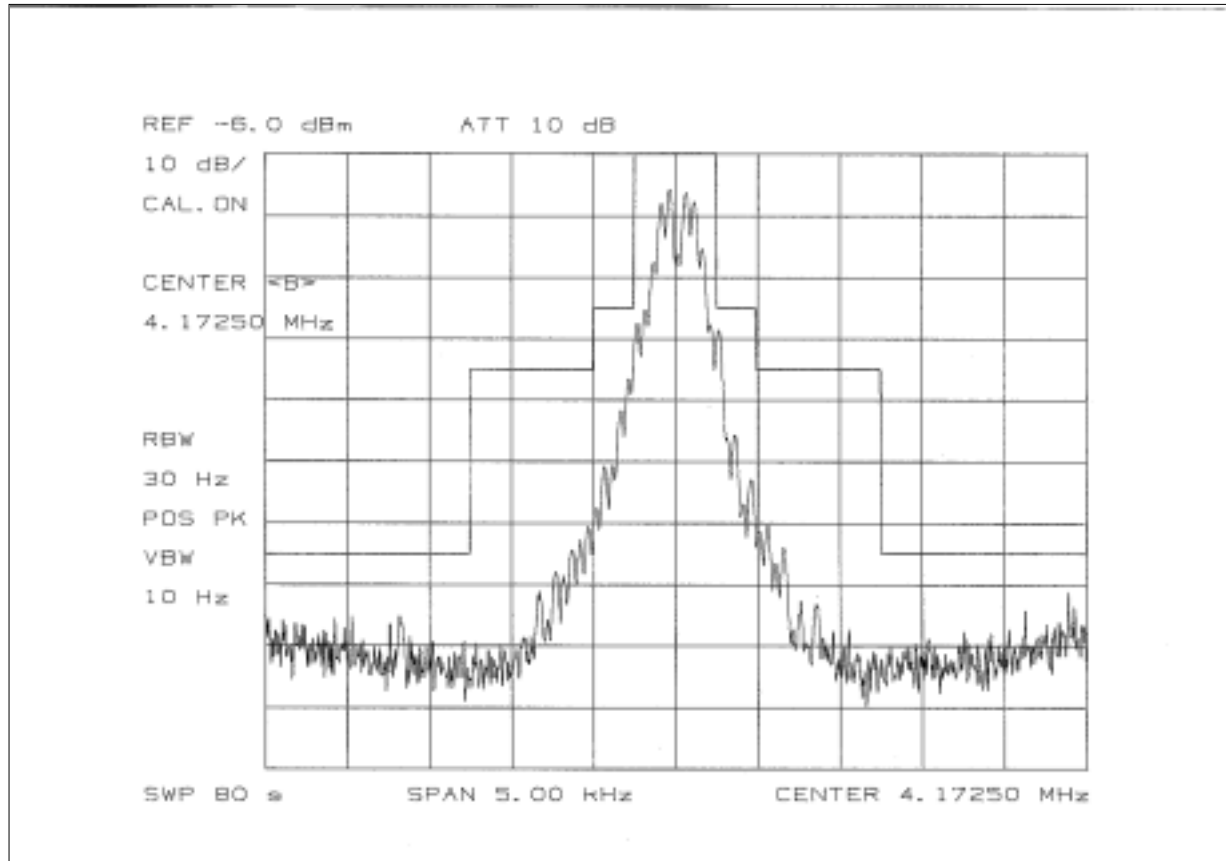

Fig. 3.3.15 - (Fc: 4 MHz, F1B/J2B)

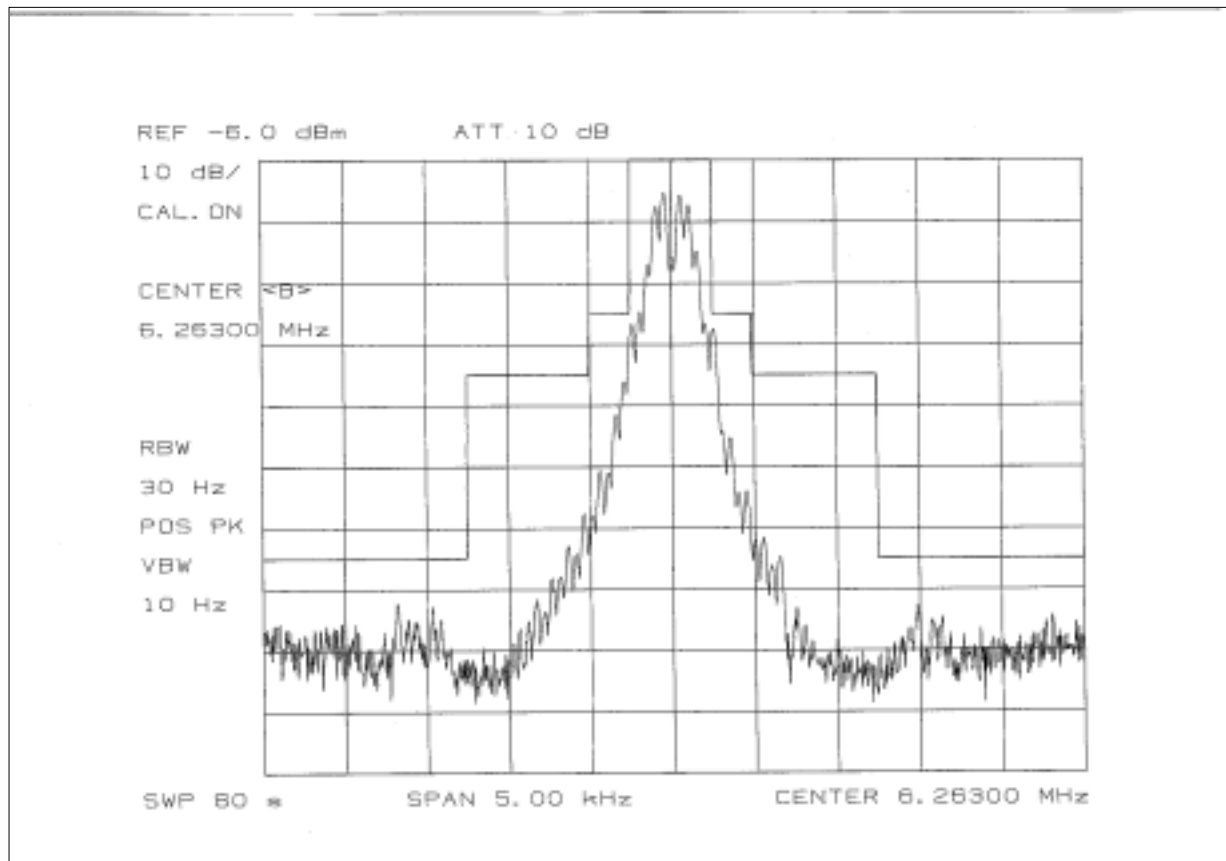

Fig. 3.3.16 - (Fc: 6 MHz, F1B/J2B)

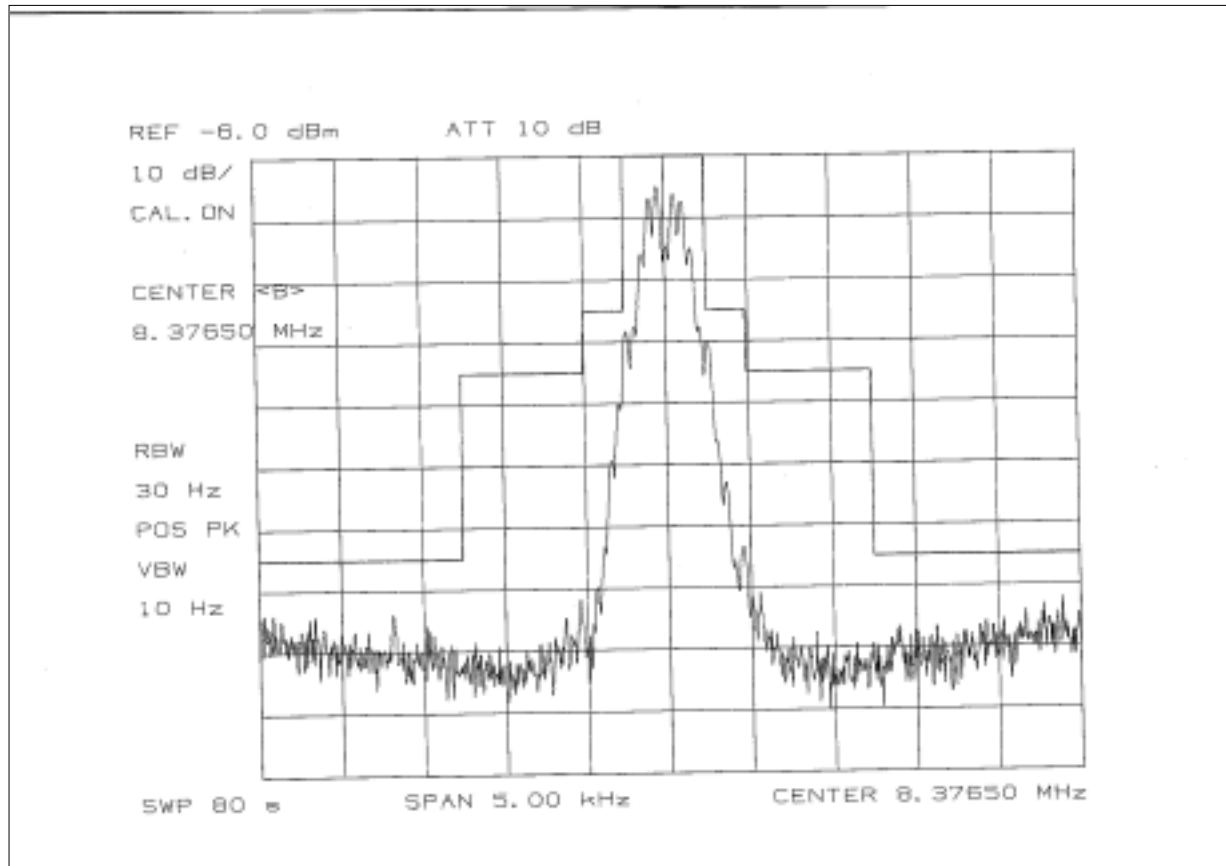

Fig. 3.3.17 - (Fc: 8 MHz, F1B/J2B)

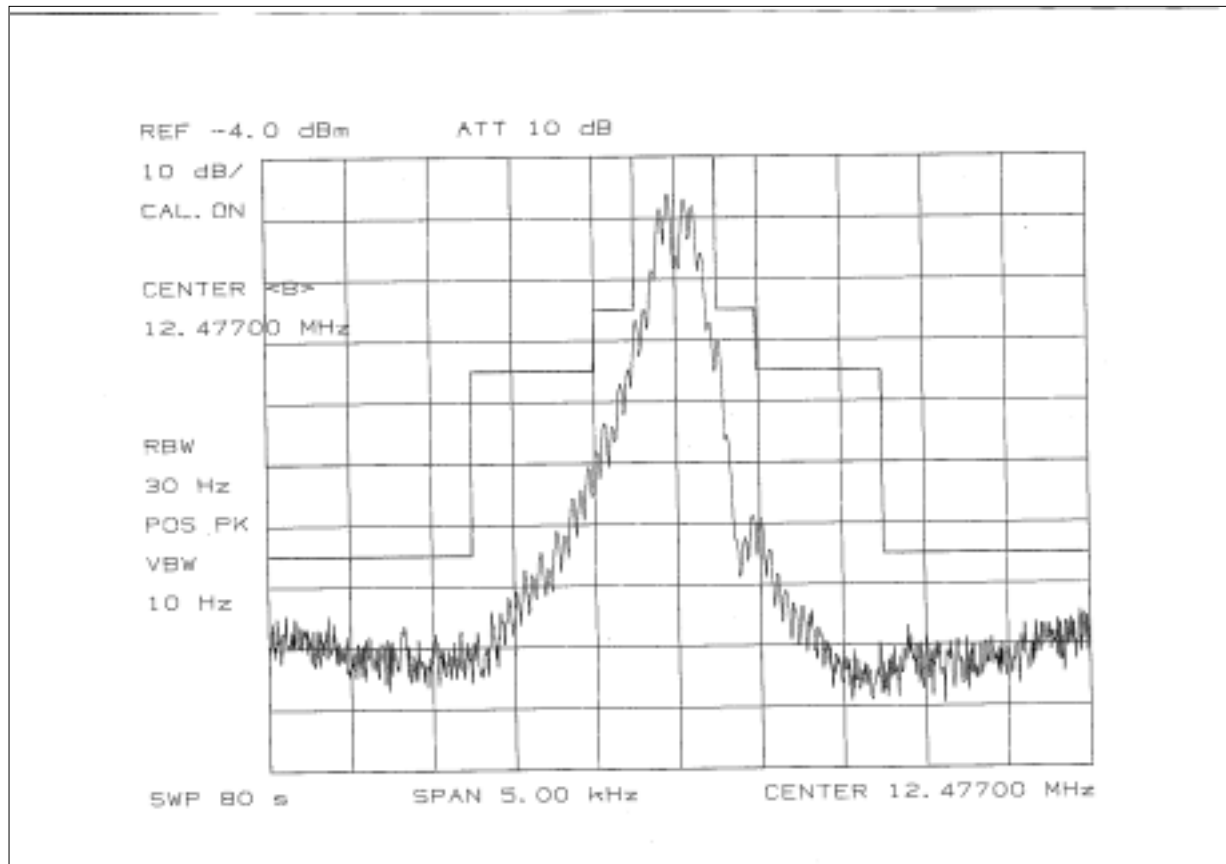

Fig. 3.3.18 - (Fc: 12 MHz, F1B/J2B)

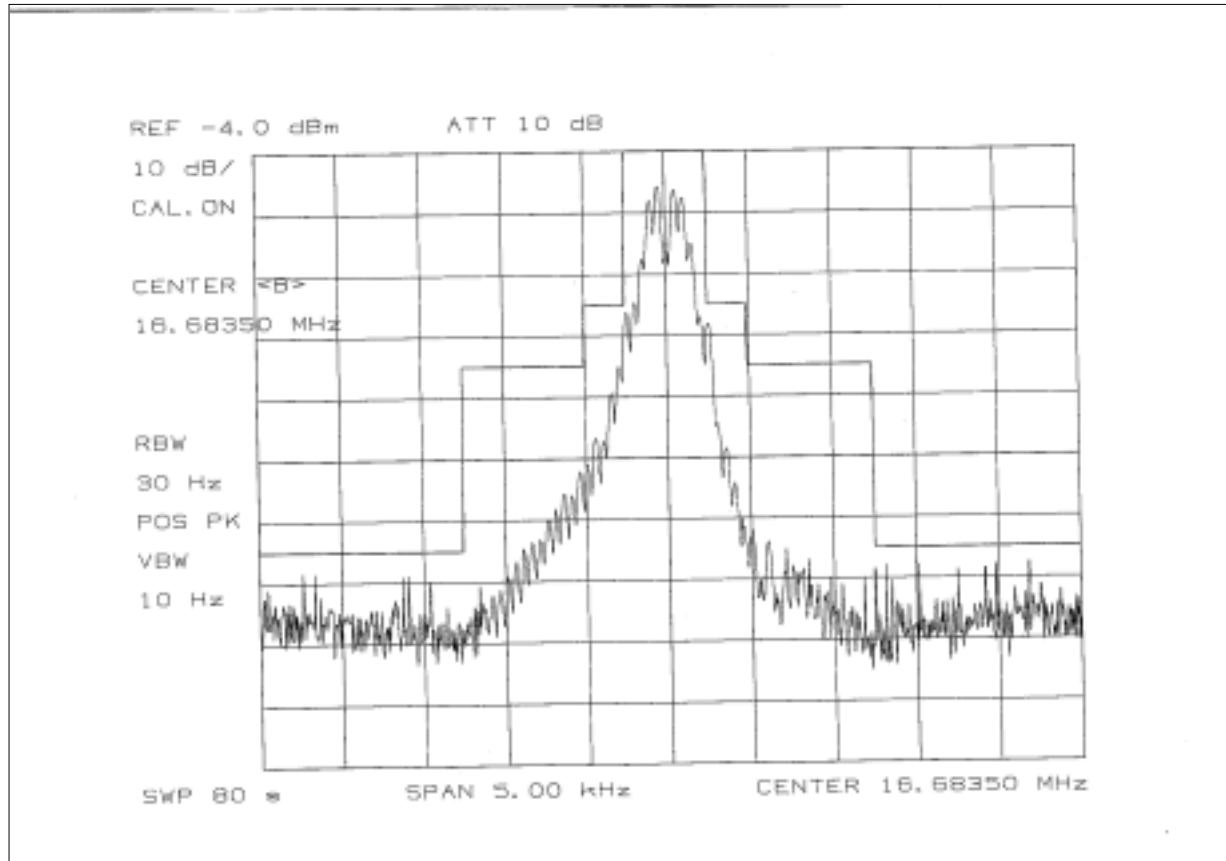

Fig. 3.3.19 - (Fc: 16 MHz, F1B/J2B)

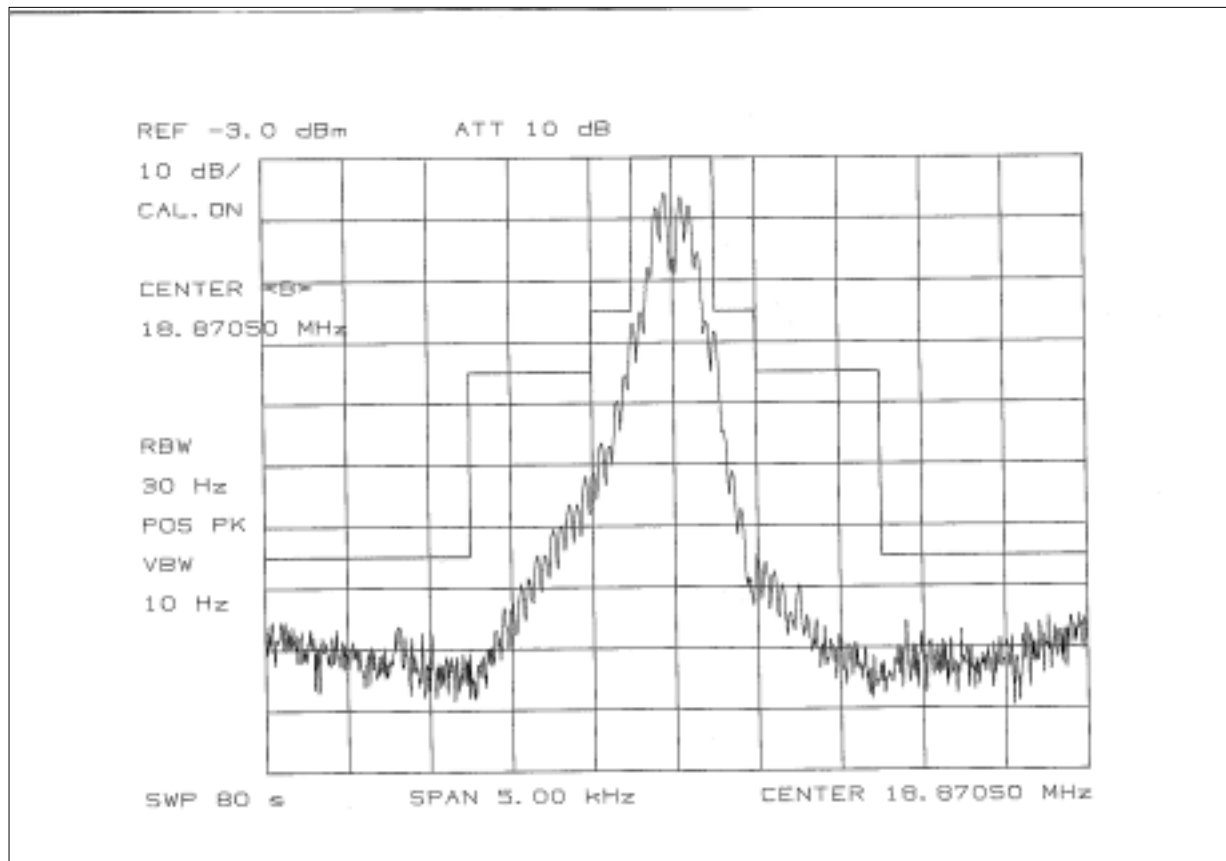

Fig. 3.3.20 - (Fc: 18 MHz, F1B/J2B)

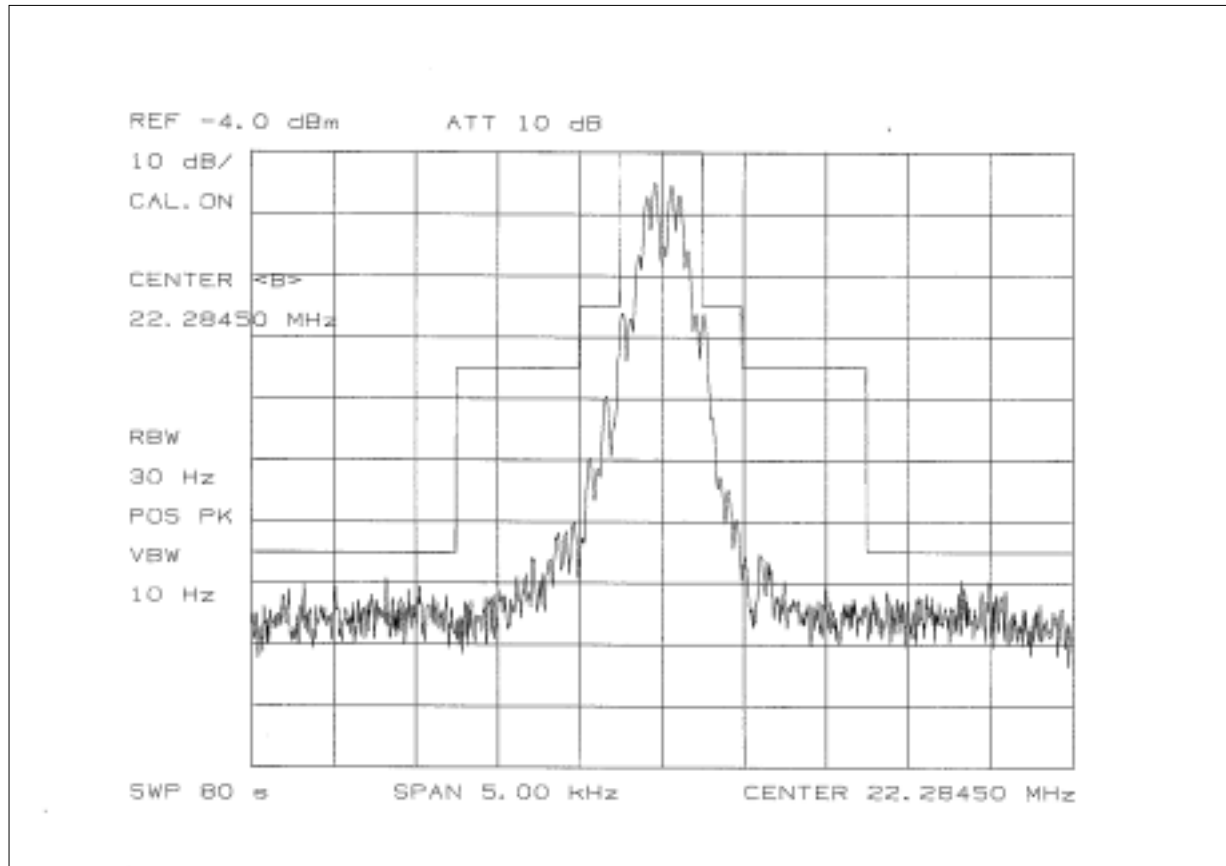

Fig. 3.3.21 - (Fc: 22 MHz, F1B/J2B)

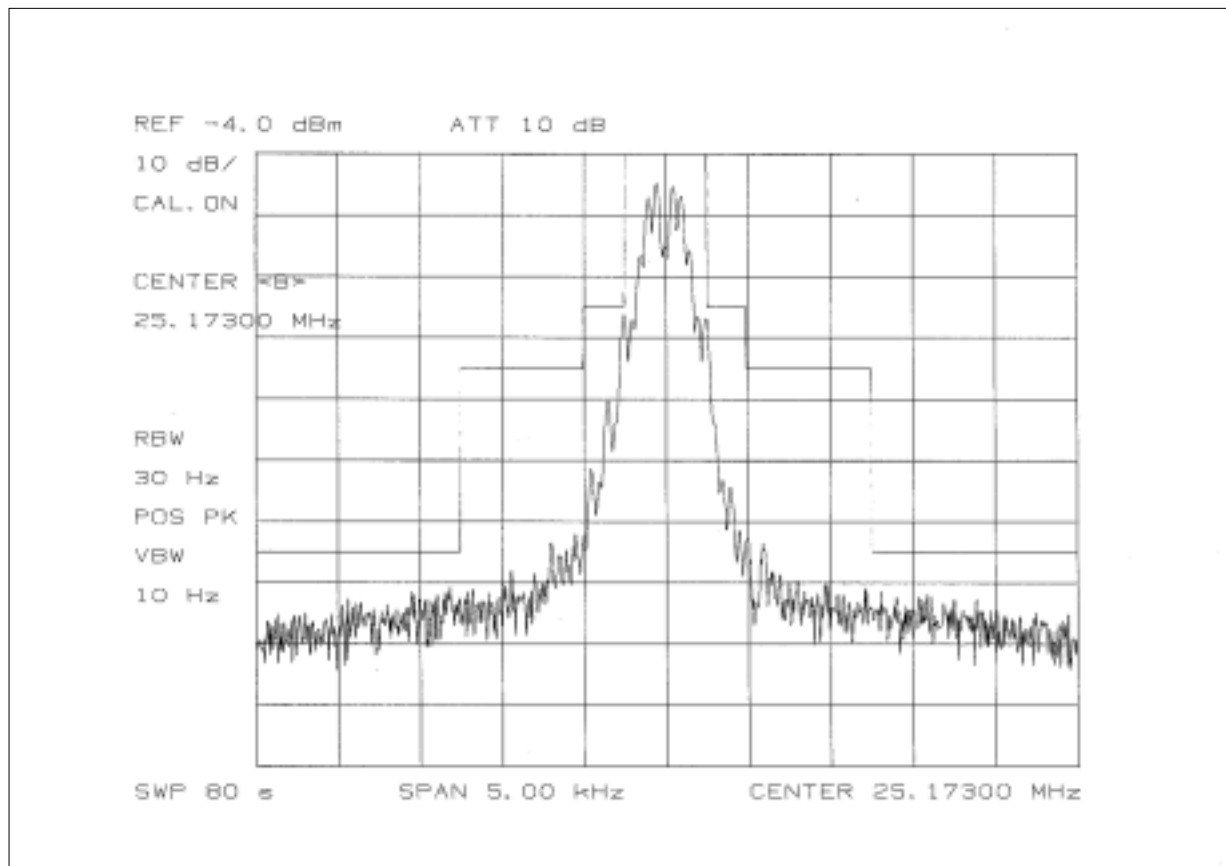

Fig. 3.3.22 - (Fc: 25 MHz, F1B/J2B)

3.4 EMISSION LIMITATIONS (FCC Rule Part 80.211)

3.4.1 Method of Measurement

The FS-1570 is connected with measuring equipment as in Fig. 3.4.1.

The transmitter is modulated with 2 audio tones 400 Hz and 1800 Hz in equal level. The input level is adjusted to 10 dB above the level producing PEP output of 150 W.

Spectrum over the frequency range ± 10 kHz of each test frequency is observed.

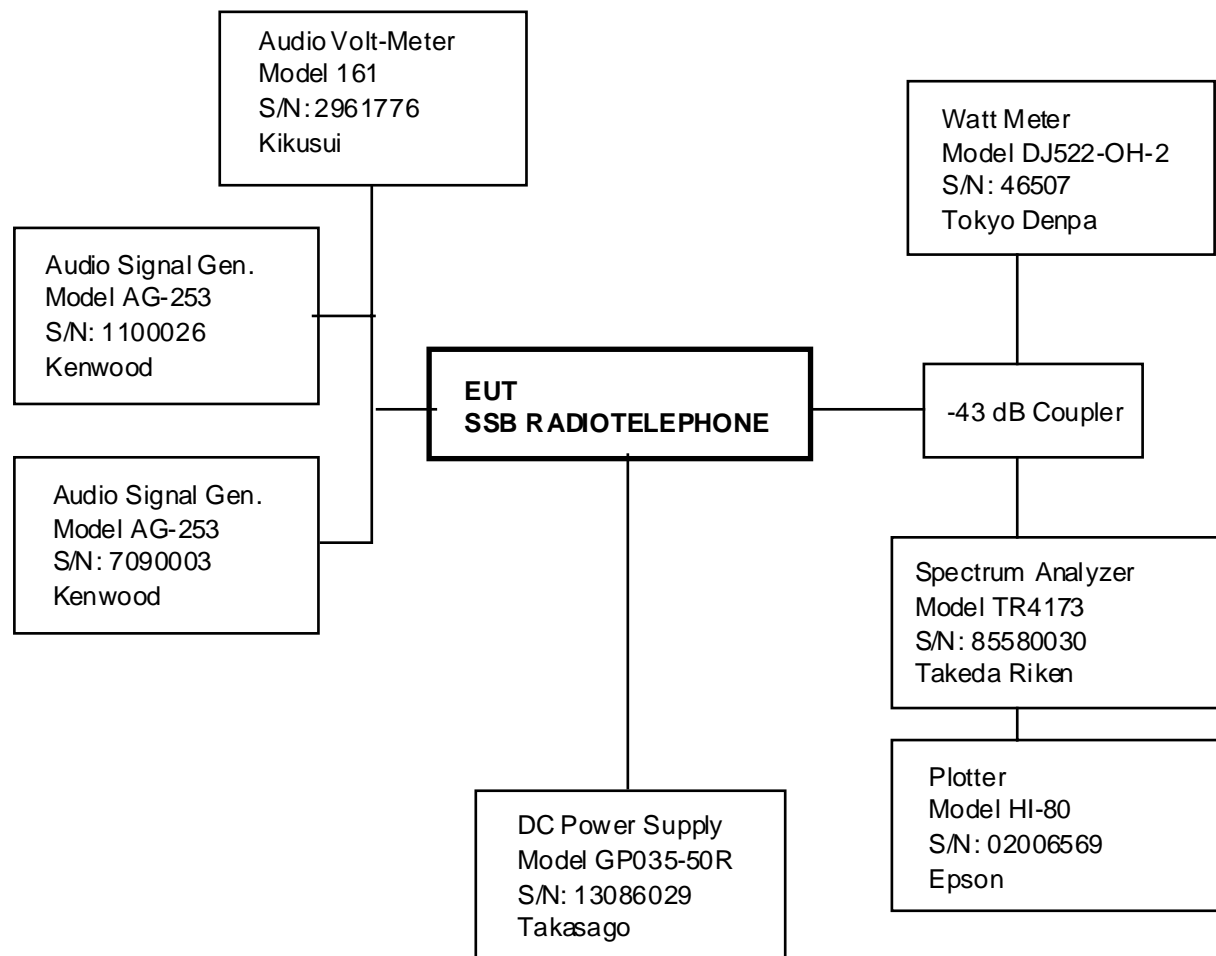

Fig. 3.4.1

3.4.2 Test Result

See Fig. 3.3.2 to 3.3.22 in Clause 3.3 of this report for details.

3.5 SPURIOUS EMISSIONS AT ANTENNA TERMINAL (FCC Rule Part 2.1051)

3.5.1 Method of Measurement

The transmitter is connected with measuring equipment as in Fig. 3.5.1.

The transmitter is modulated with 2 audio tones 400 Hz and 1800 Hz in equal level. The input level is adjusted to 10 dB above the level producing PEP output of 150 W.

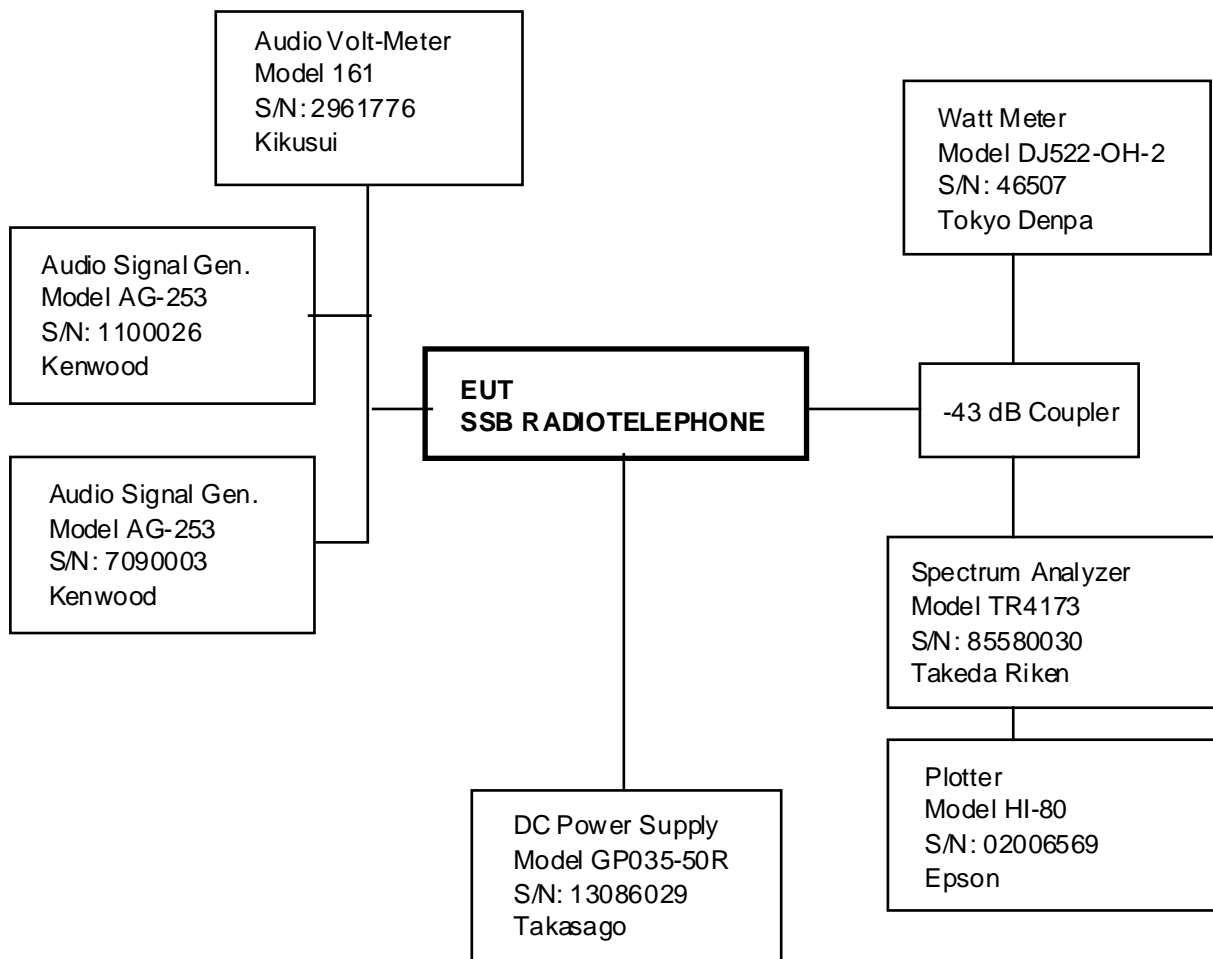

Fig. 3.5.1

3.5.2 Test Result

See Fig. 3.5.2 to 3.5.24 for the Spectrum on each test frequency. On test frequencies spectrum is observed with 2 sweep rates.

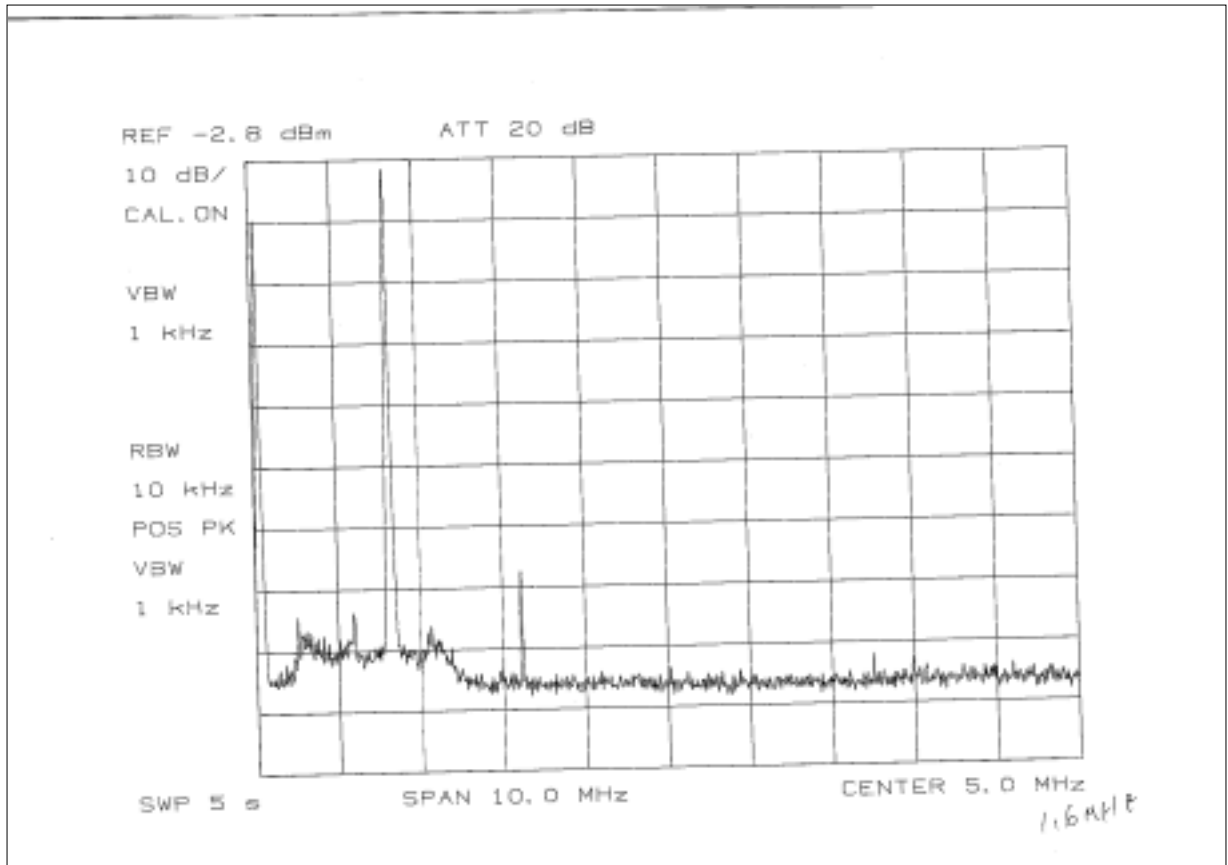

Fig. 3.5.2 - (Fc: 1605 kHz, J3E)

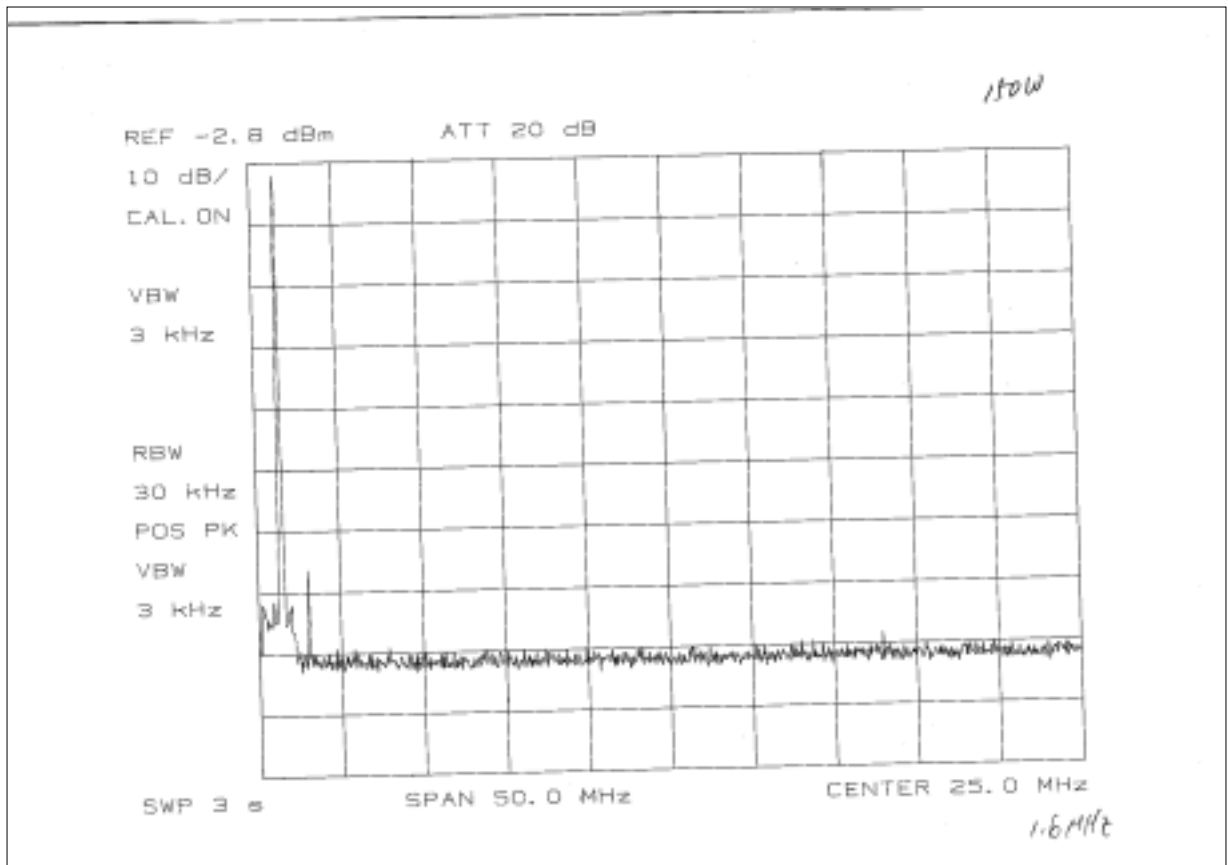

Fig. 3.5.3 - (Fc: 1605 kHz, J3E)

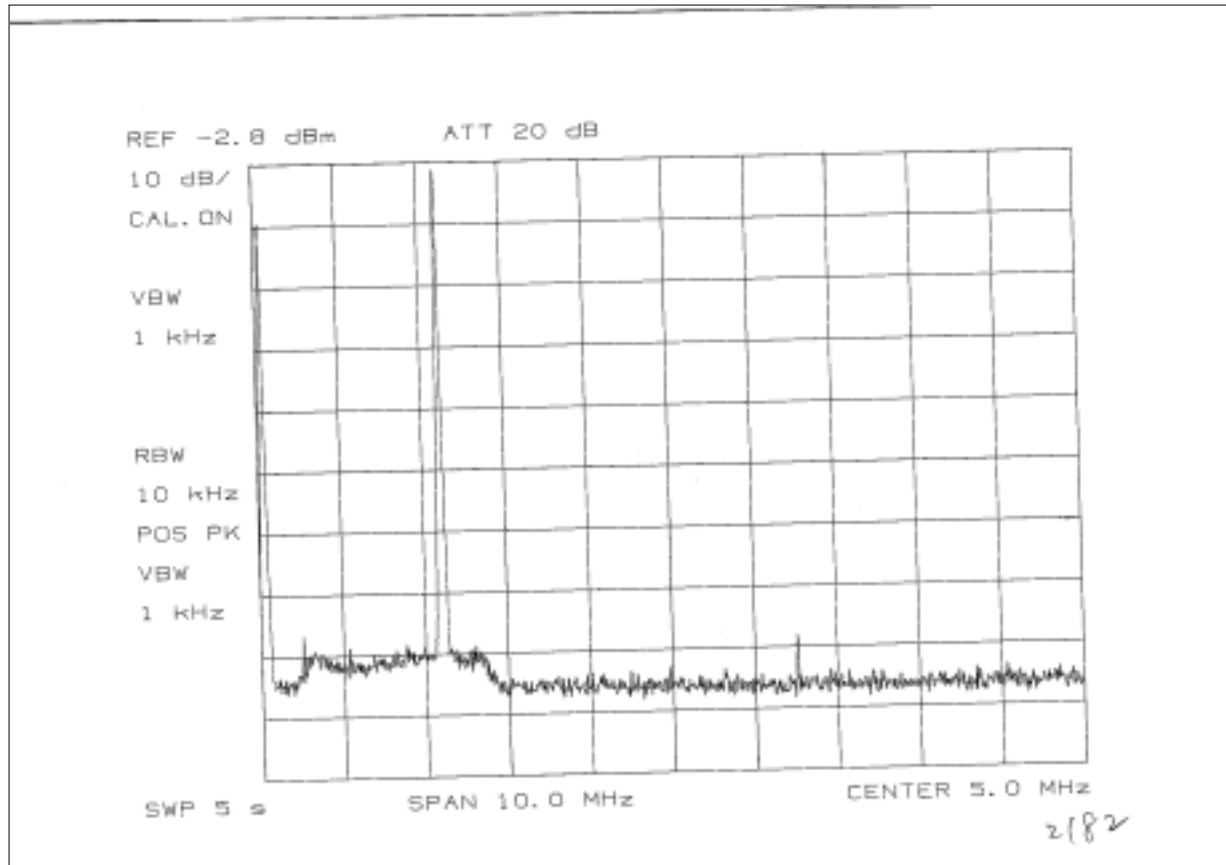

Fig. 3.5.4 - (Fc: 2182 kHz, J3E)

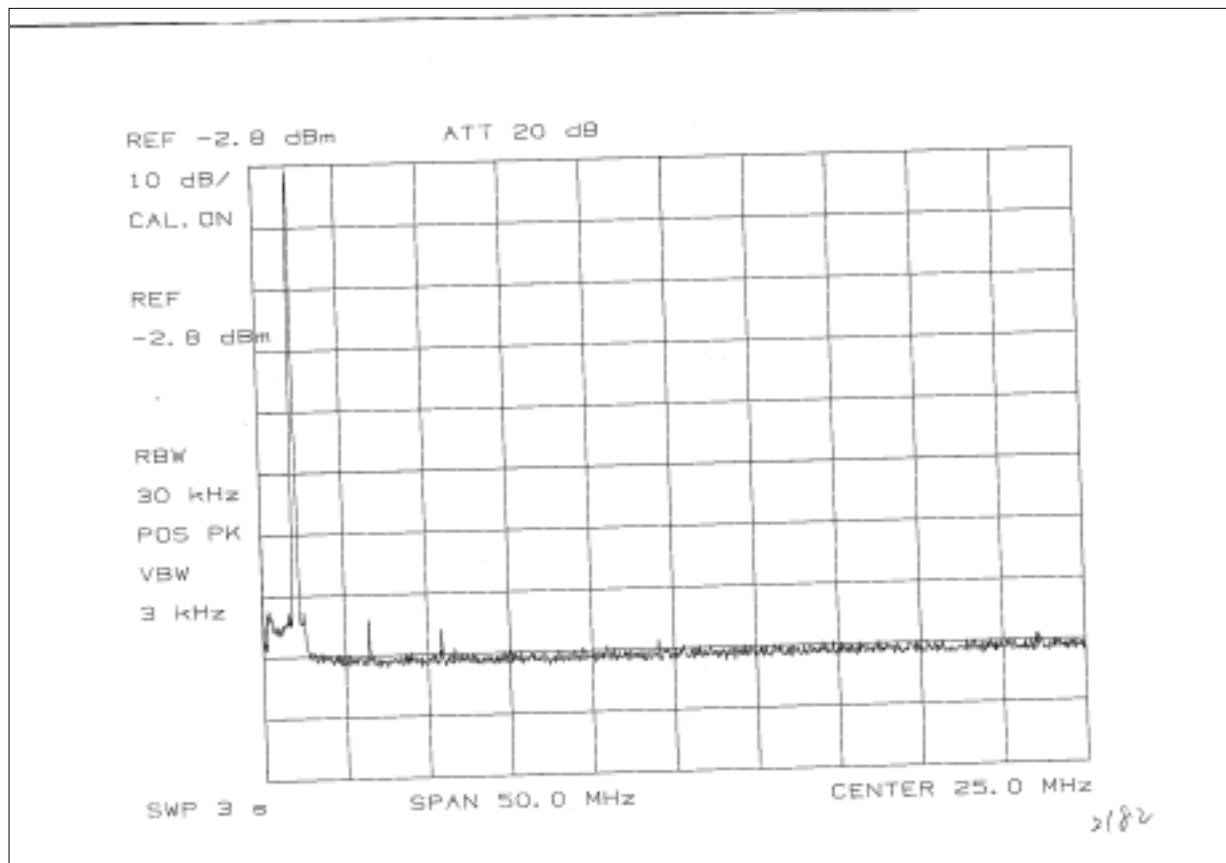

Fig. 3.5.5 - (Fc: 2182 kHz, J3E)

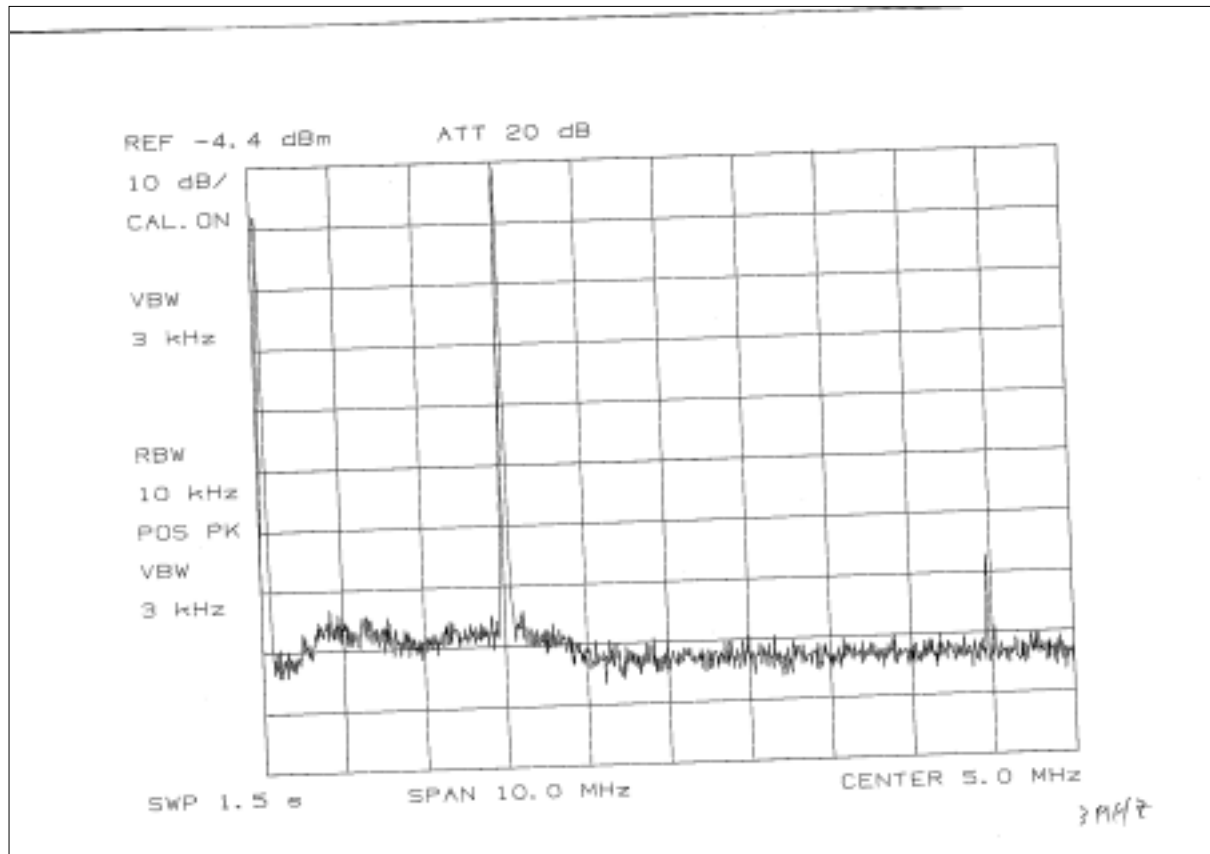

Fig. 3.5.6 - (Fc: 3000 kHz, J3E)

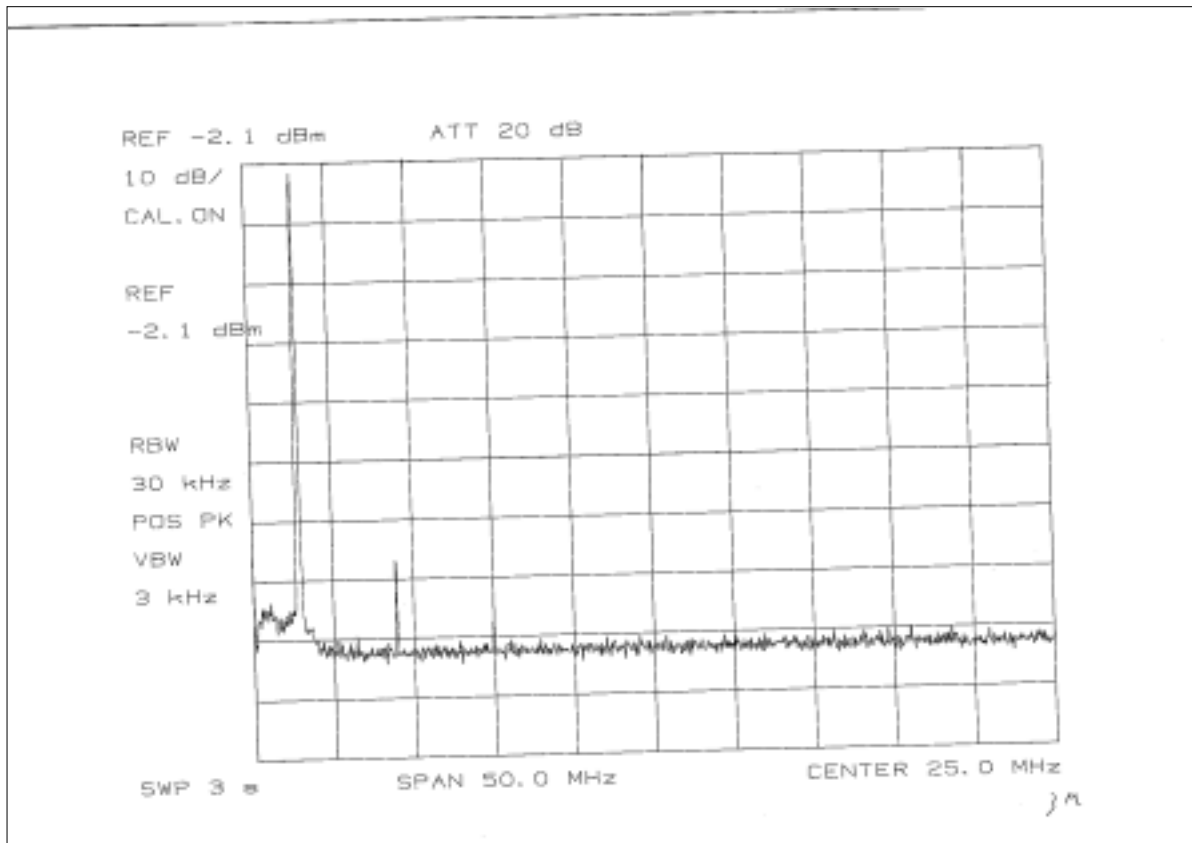

Fig. 3.5.7 - (Fc: 3000 kHz, J3E)

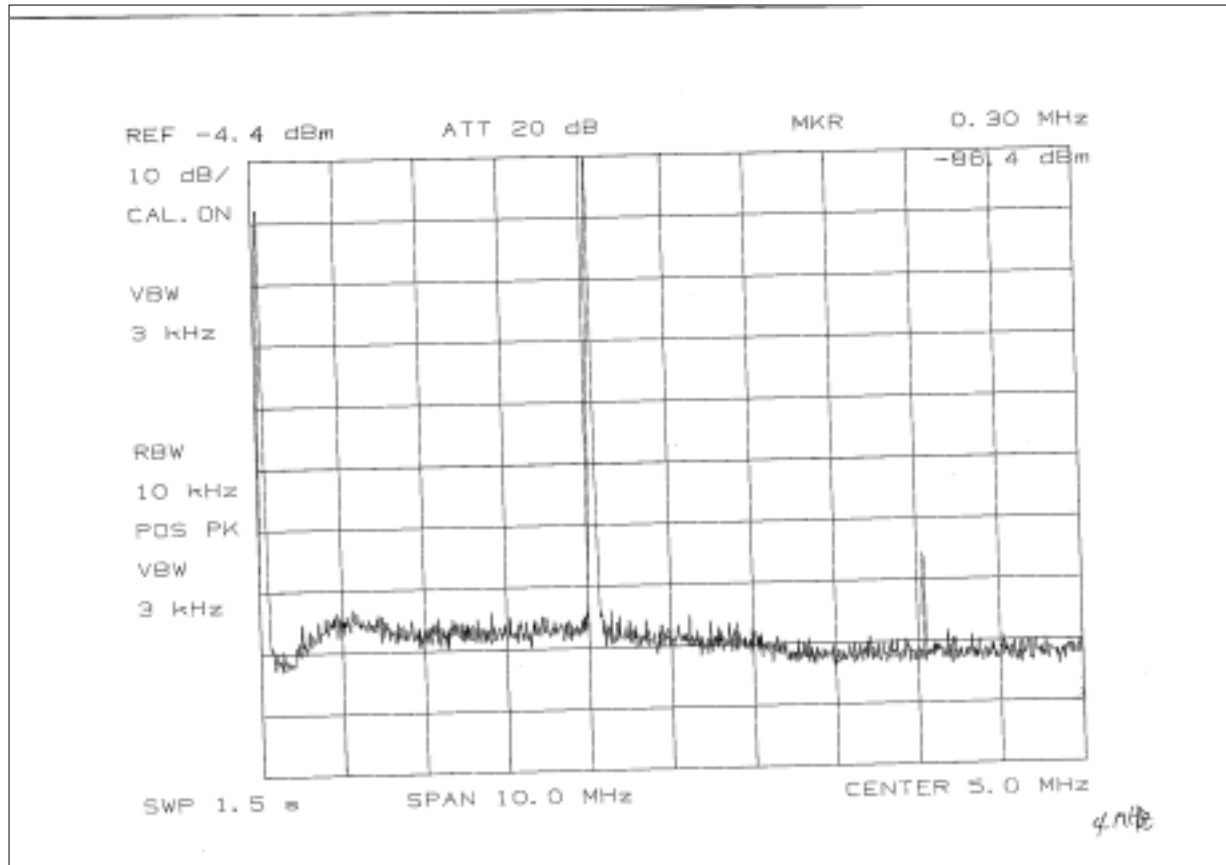

Fig. 3.5.8 - (Fc: 4065 kHz, J3E)

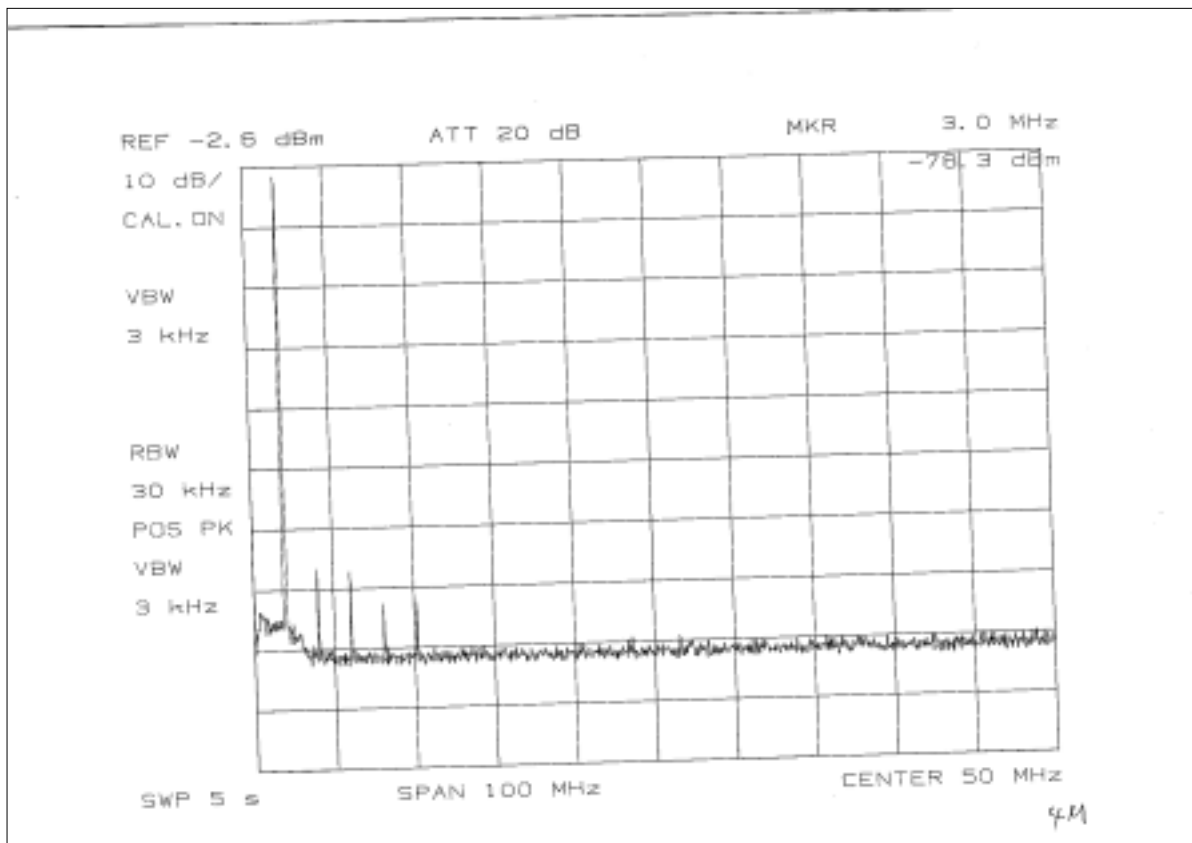

Fig. 3.5.9 - (Fc: 4065 kHz, J3E)

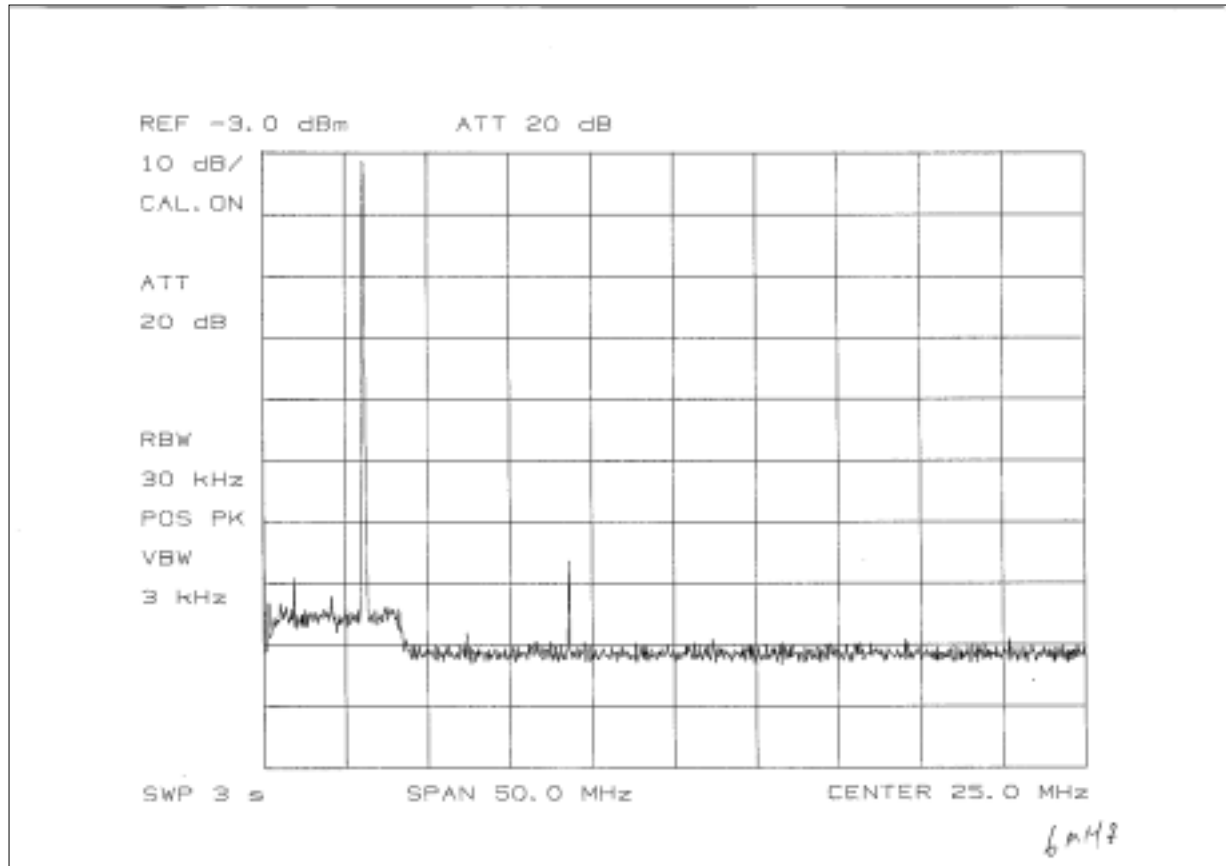

Fig. 3.5.10 - (Fc: 6200 kHz, J3E)

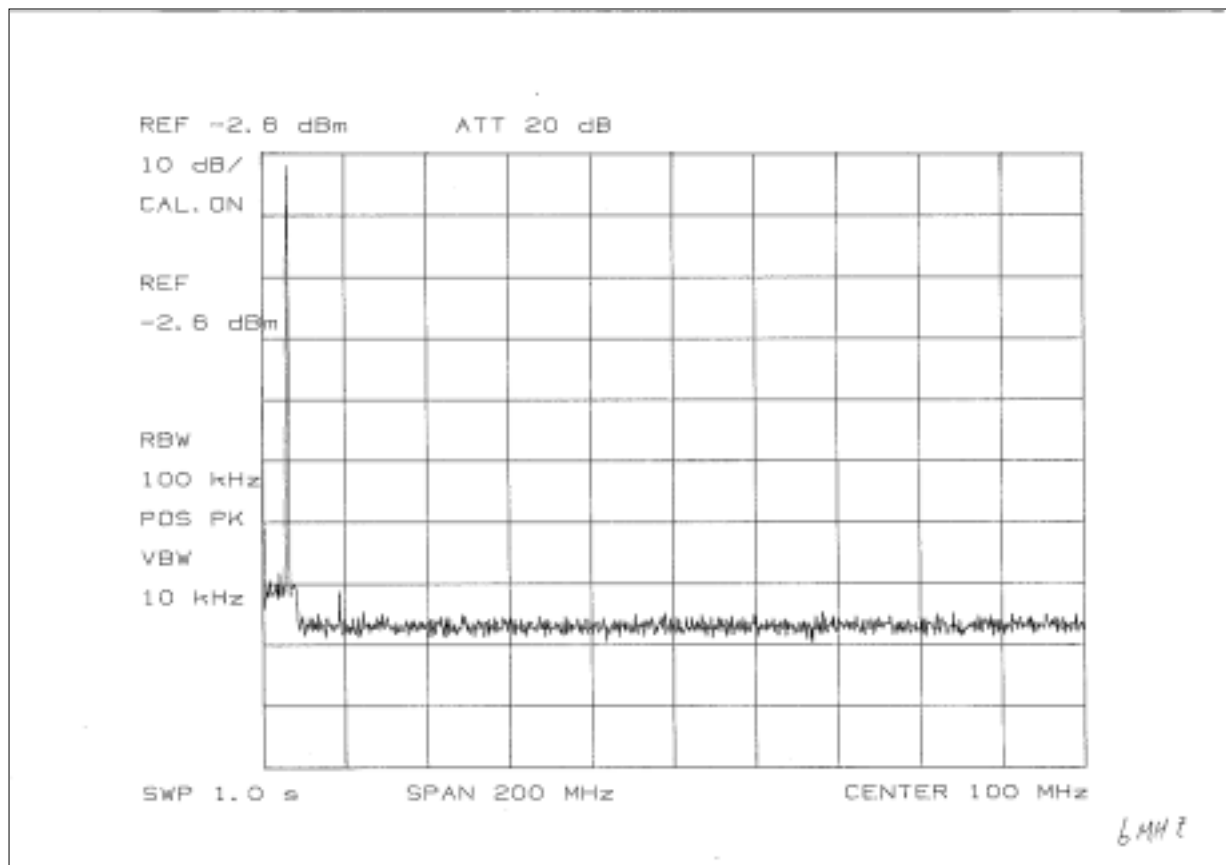

Fig. 3.5.11 - (Fc: 6200 kHz, J3E)

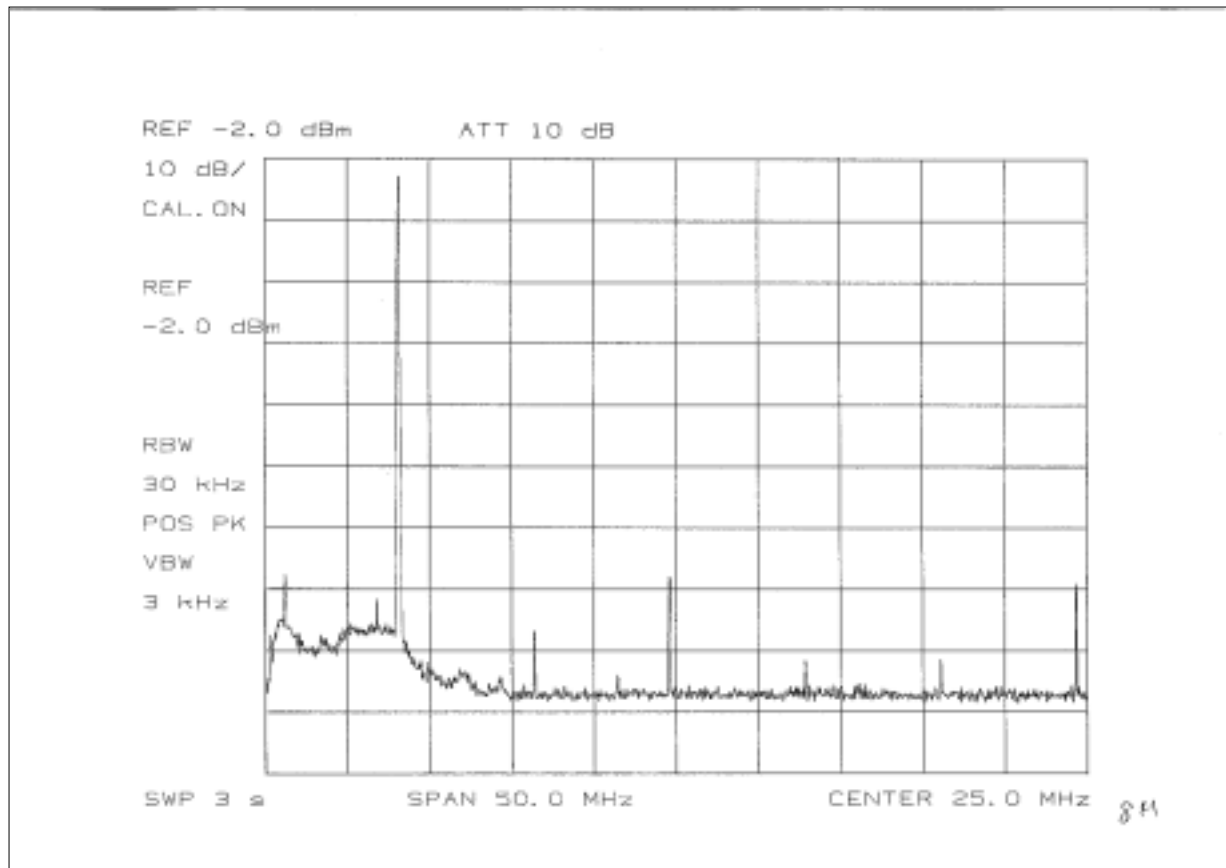

Fig. 3.5.12 - (Fc: 8195 kHz, J3E)

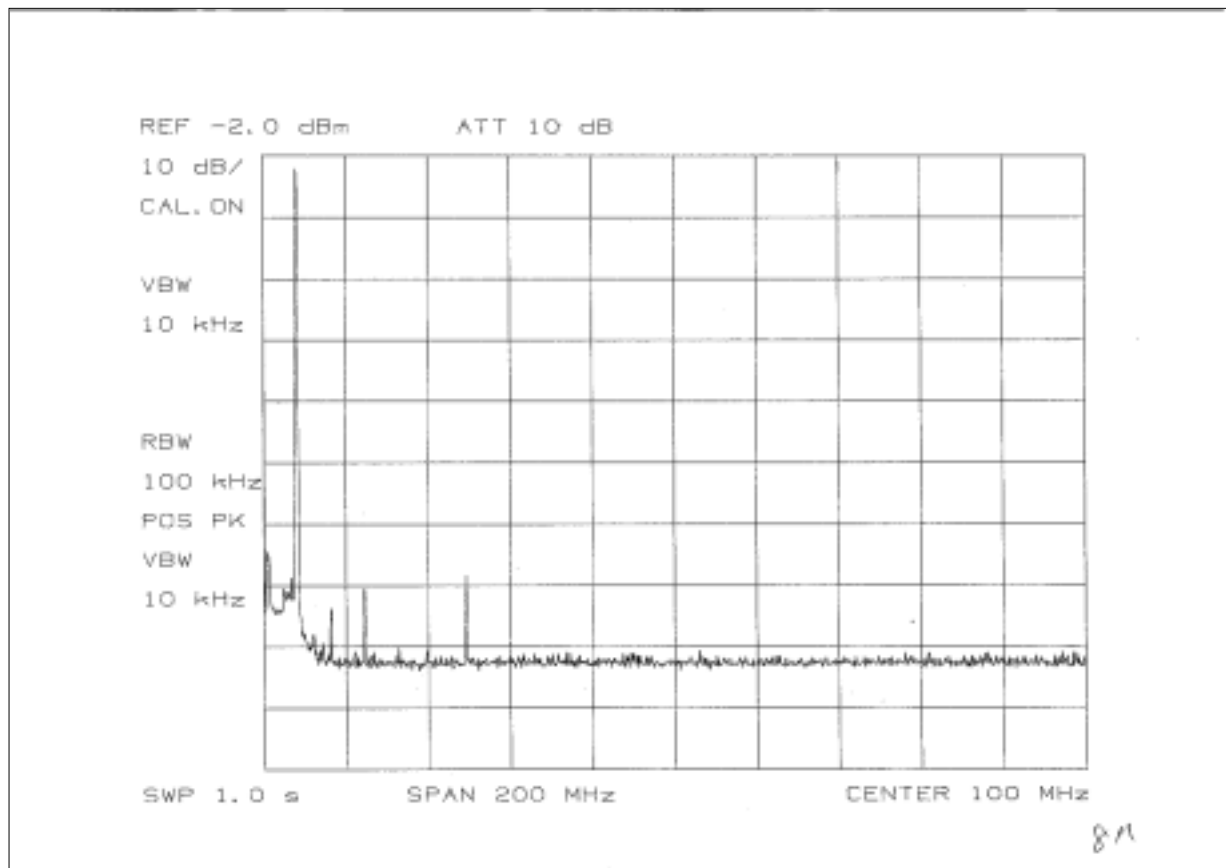

Fig. 3.5.13 - (Fc: 8195 kHz, J3E)

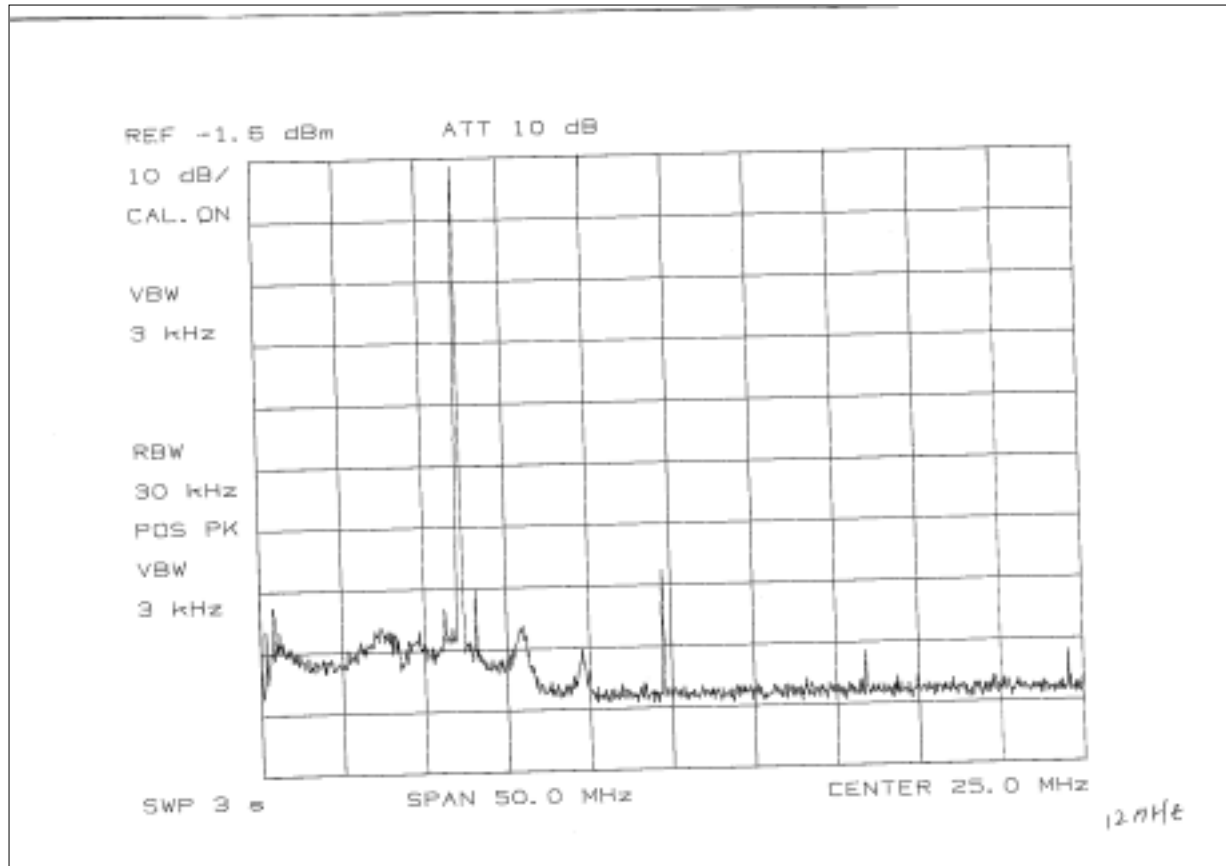

Fig. 3.5.14 - (Fc: 12330 kHz, J3E)

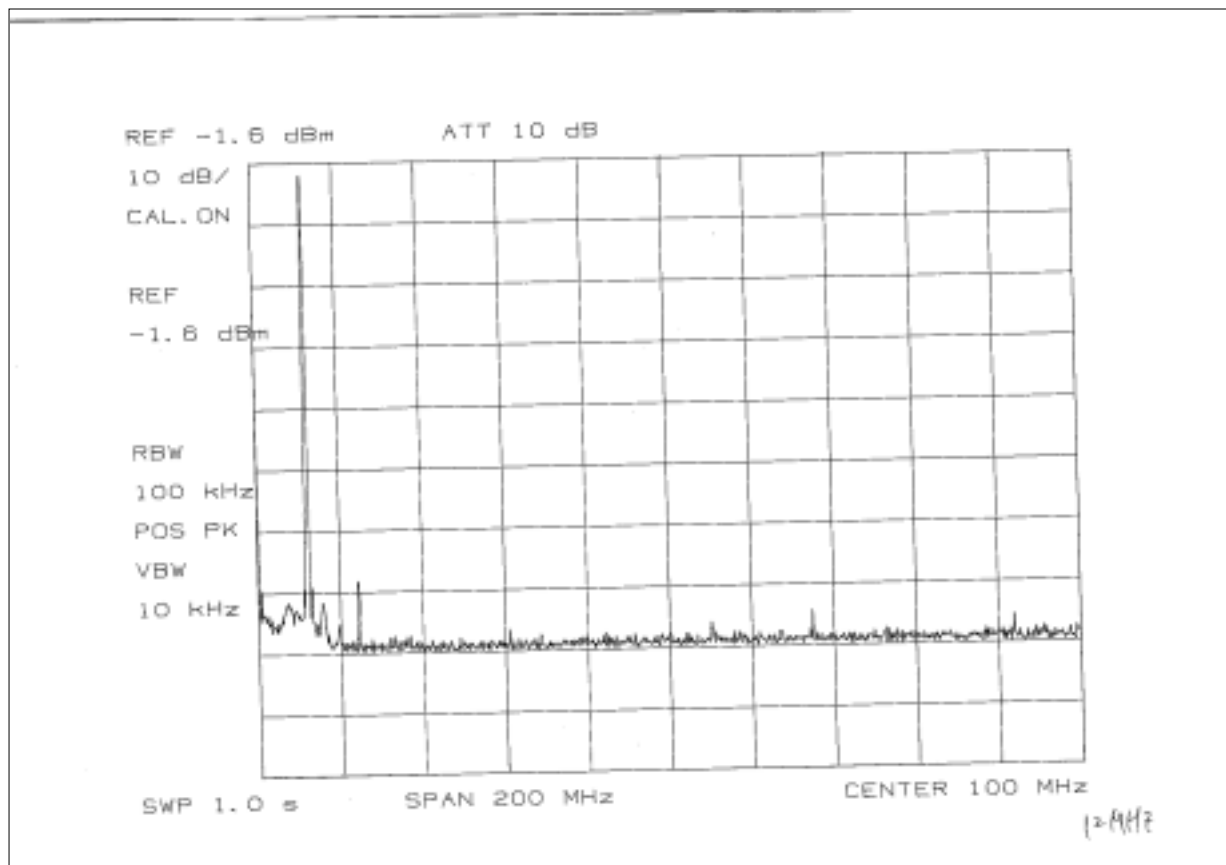

Fig. 3.5.15 - (Fc: 12330 kHz, J3E)

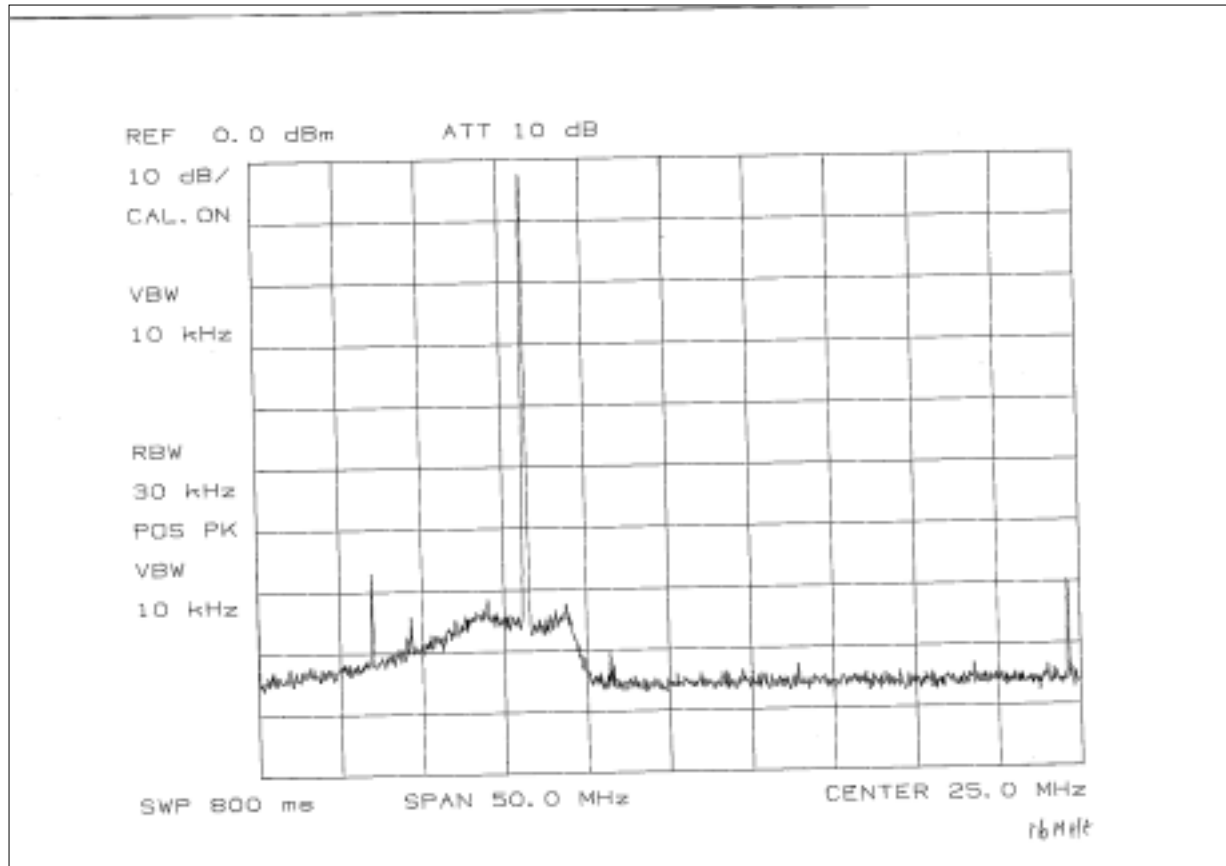

Fig. 3.5.16 - (Fc: 16360 kHz, J3E)

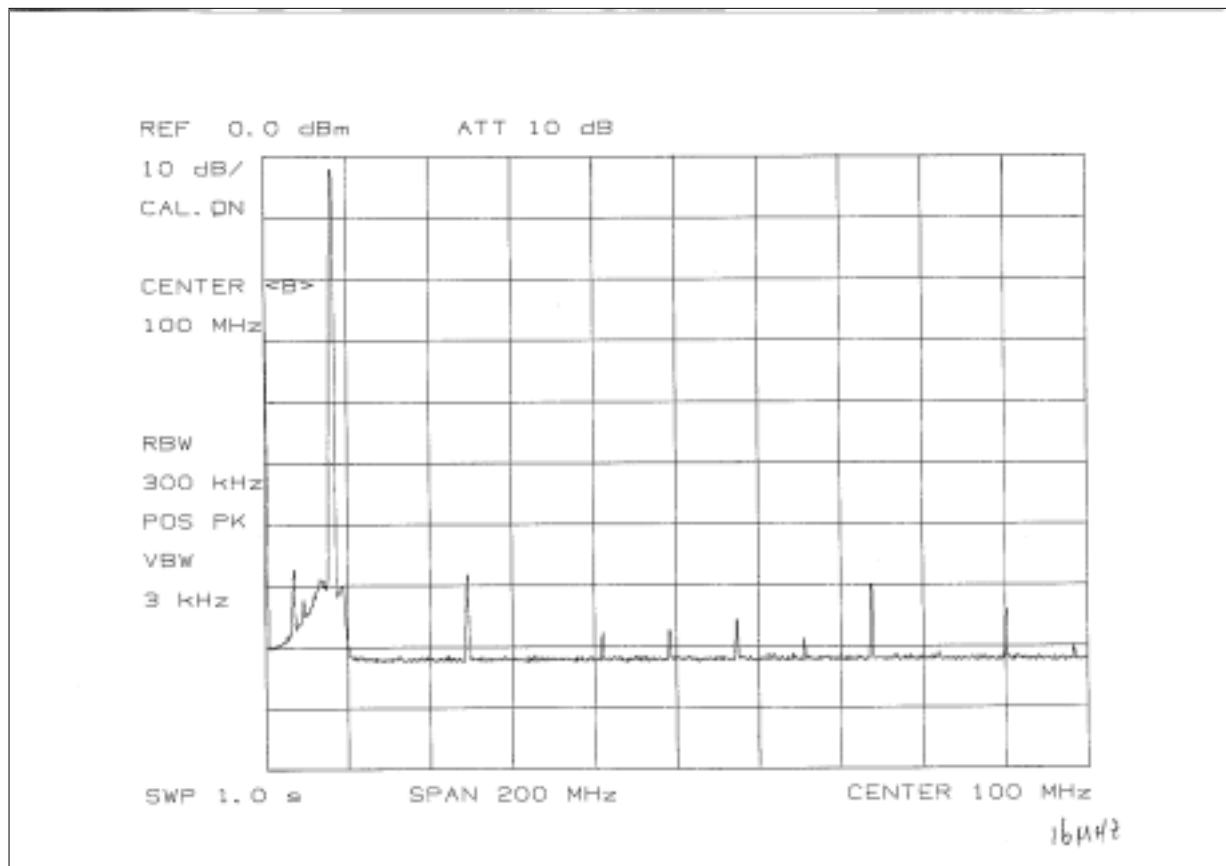

Fig. 3.5.17 - (Fc: 16360 kHz, J3E)

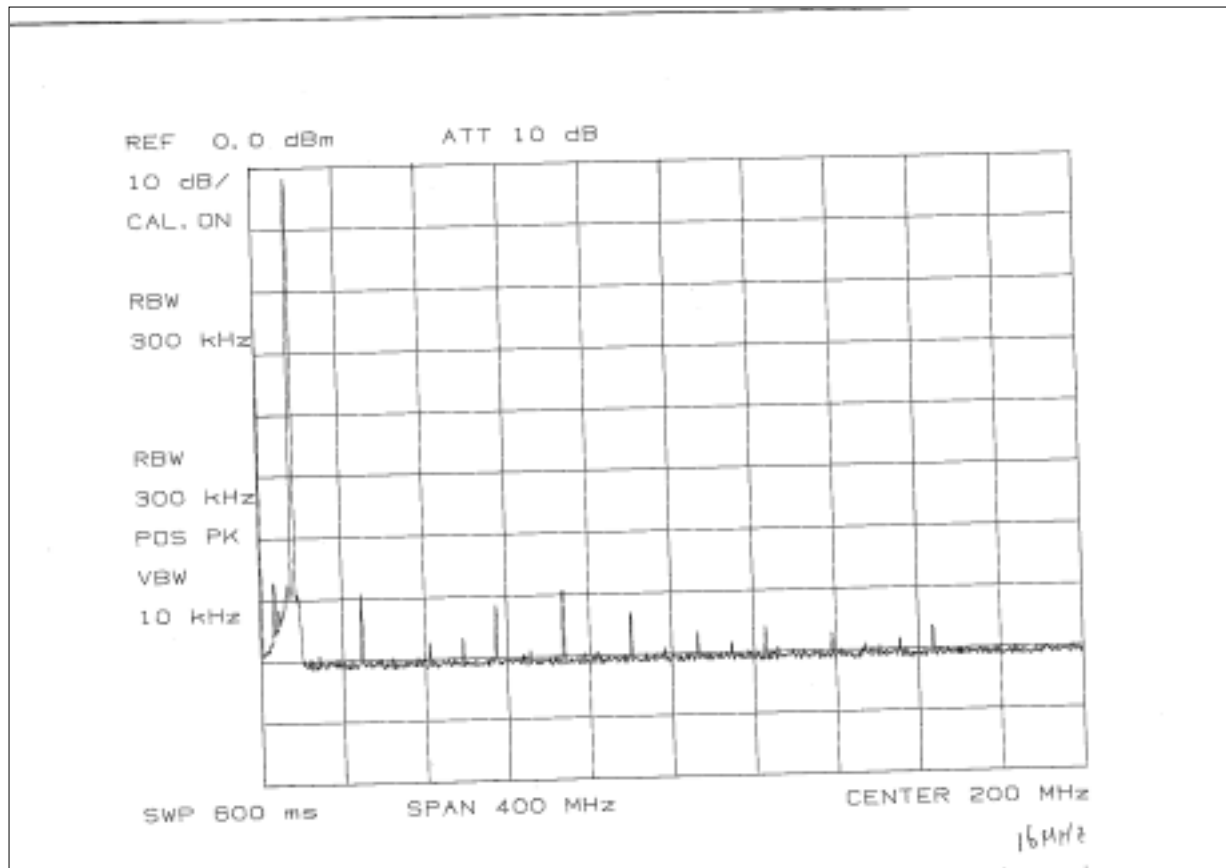

Fig. 3.5.18 - (Fc: 16360 kHz, J3E)

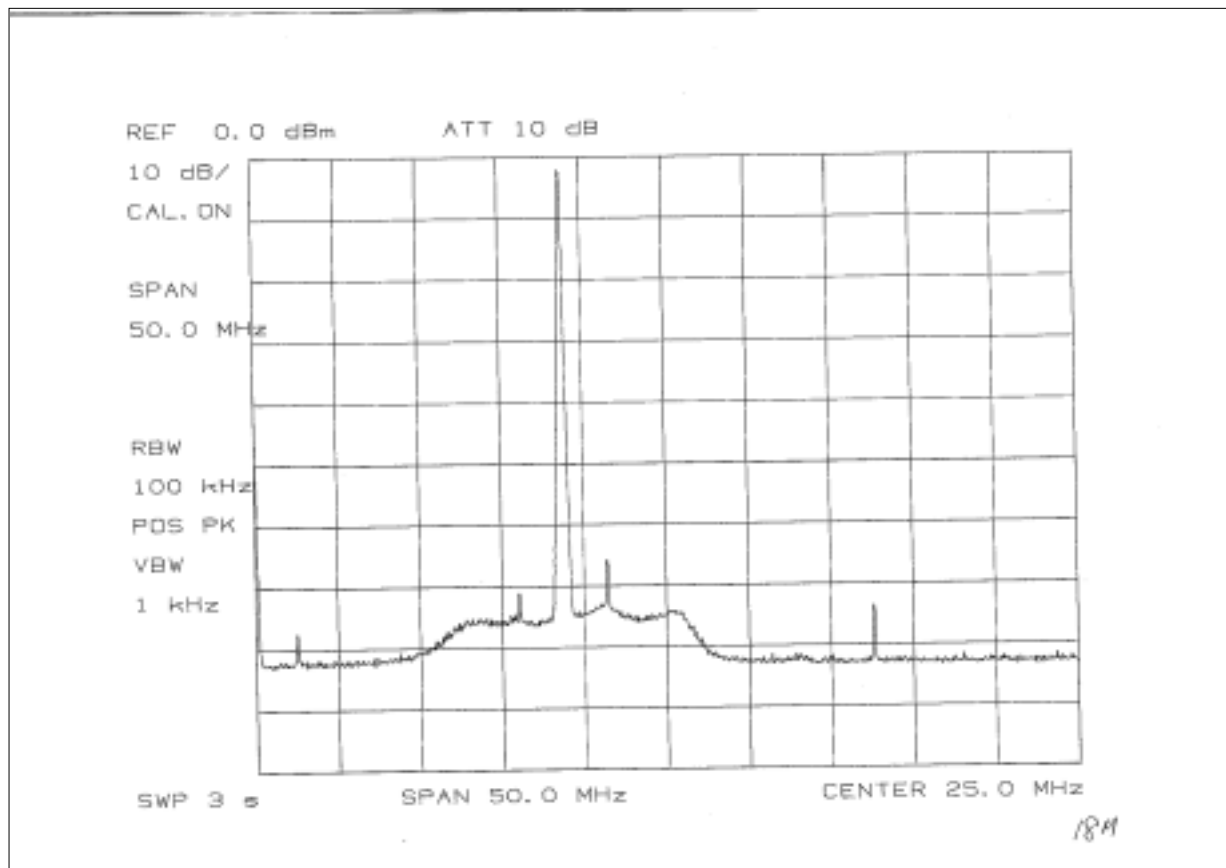

Fig. 3.5.19 - (Fc: 18780 kHz, J3E)

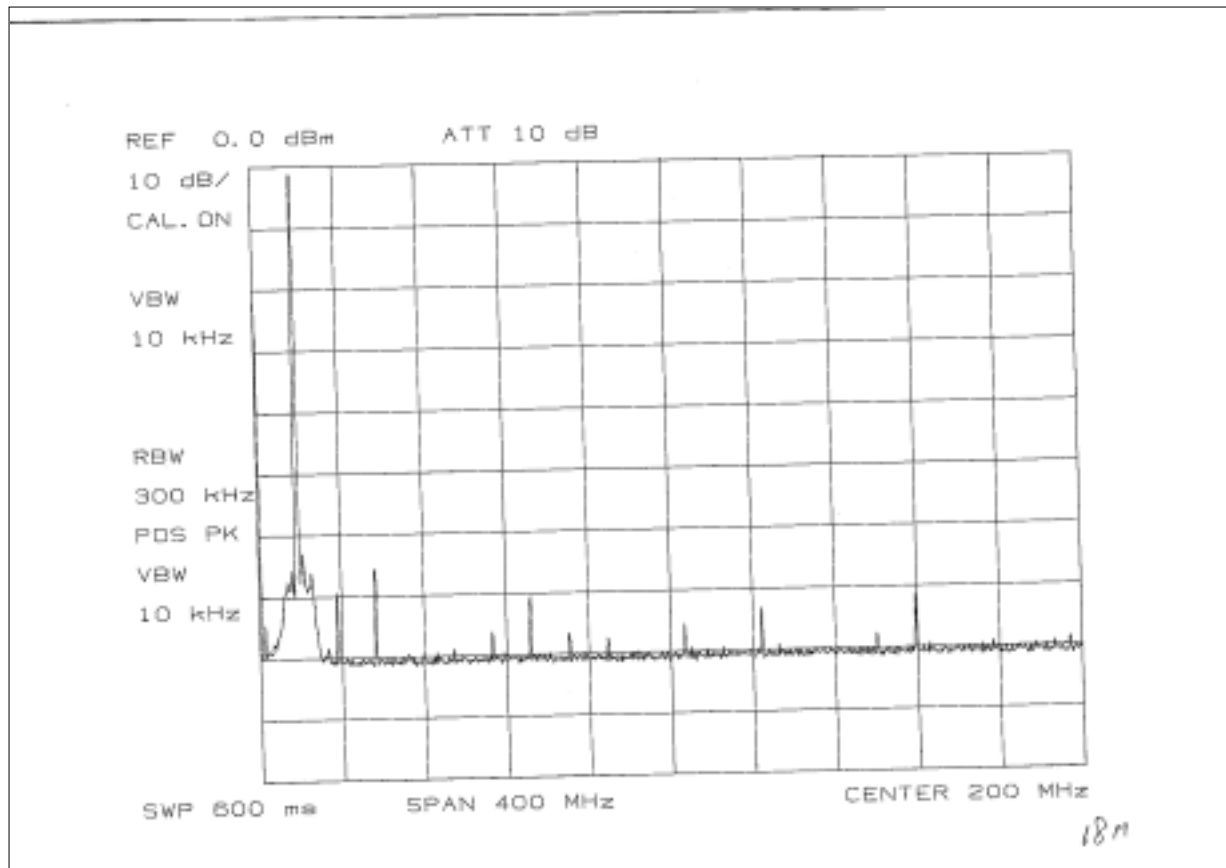

Fig. 3.5.20 - (Fc: 18780 kHz, J3E)

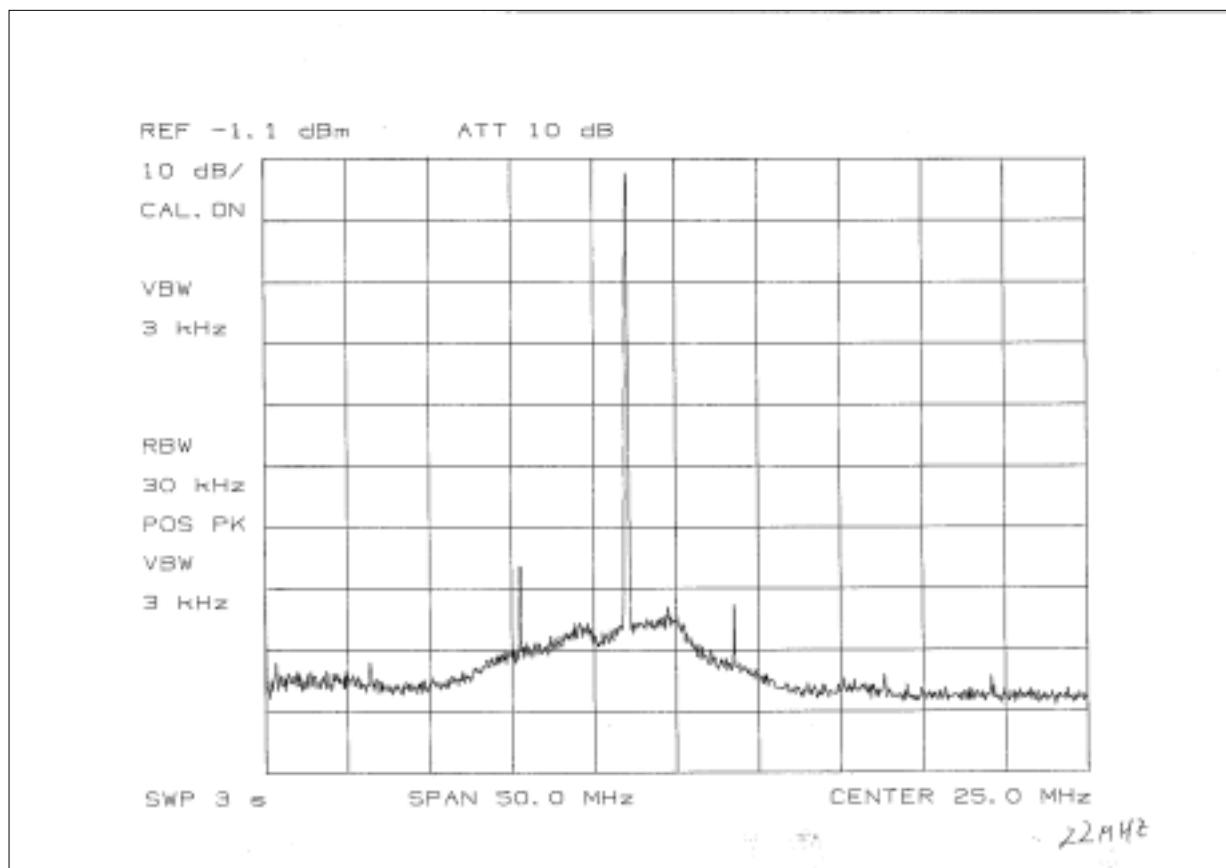

Fig. 3.5.21 - (Fc: 22000 kHz, J3E)

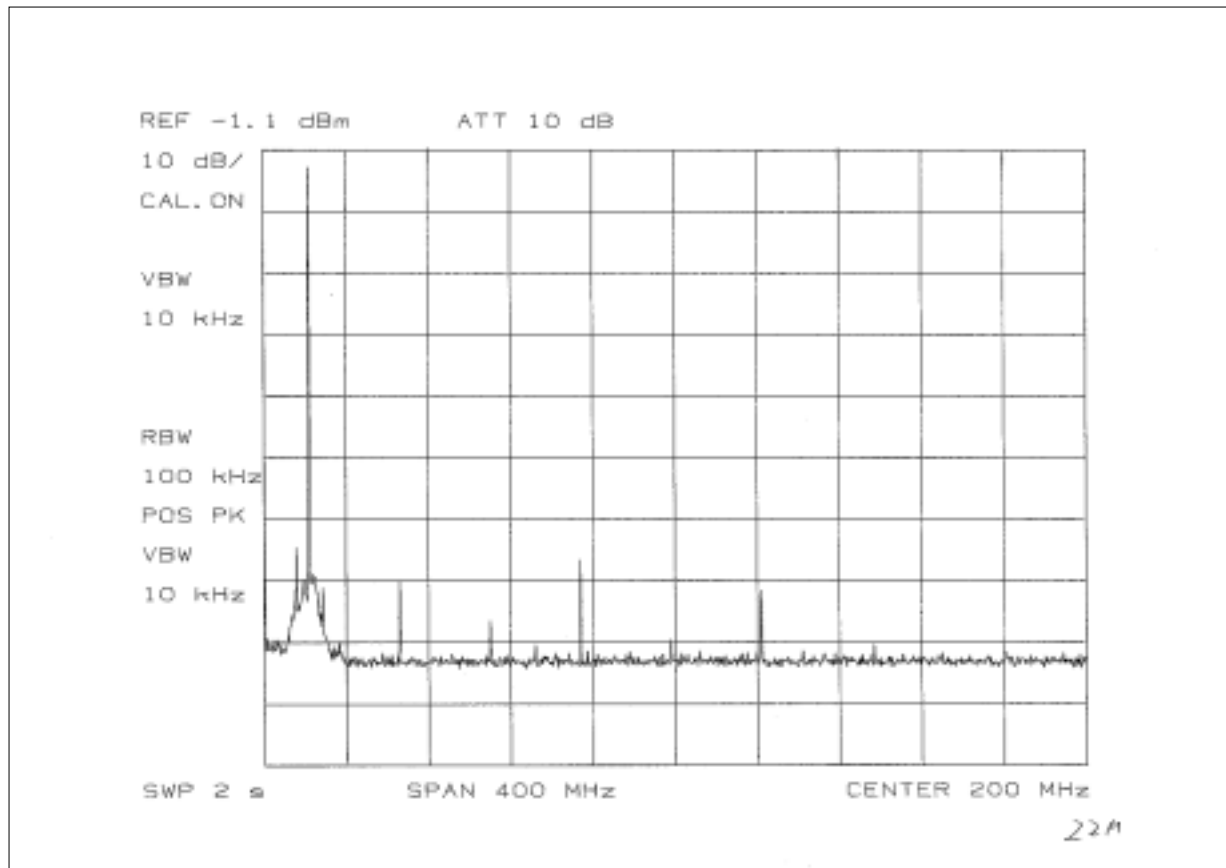

Fig. 3.5.22 - (Fc: 22000 kHz, J3E)

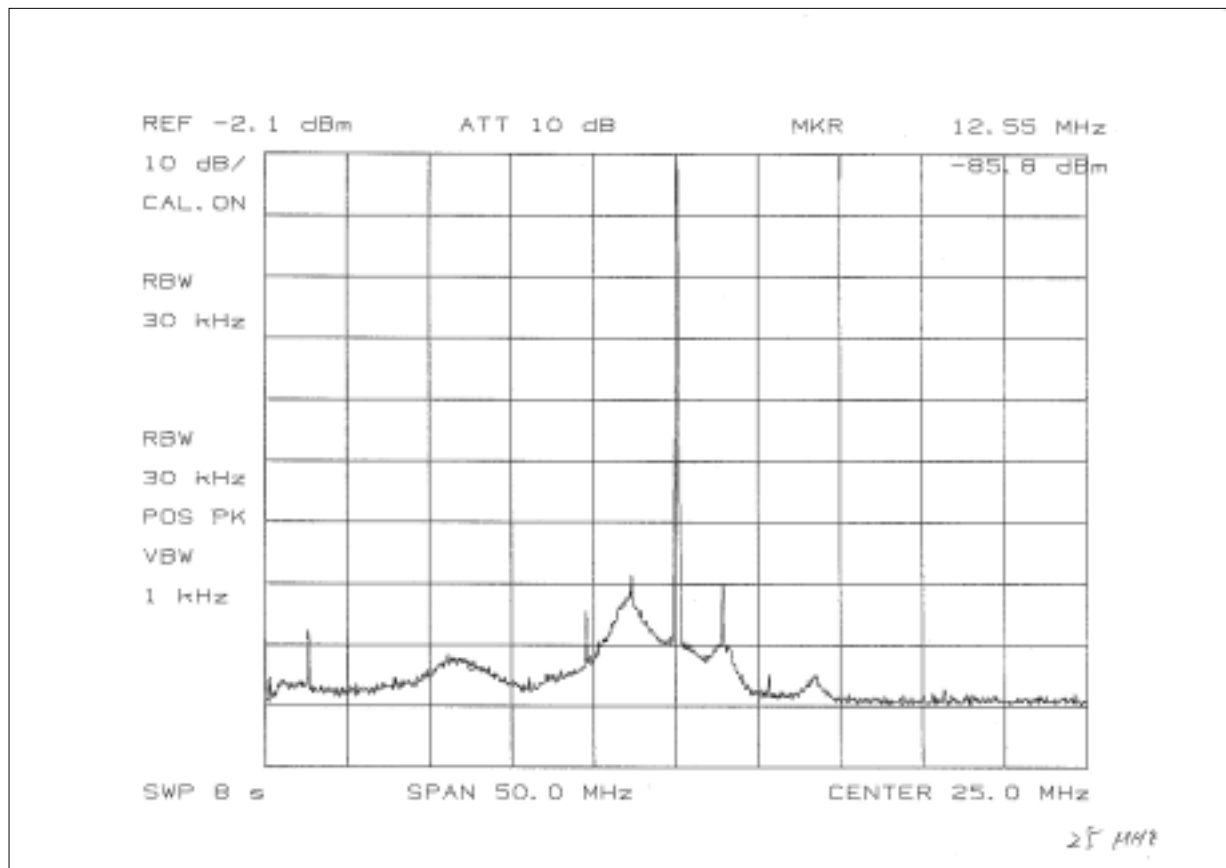

Fig. 3.5.23 - (Fc: 25700 kHz, J3E)

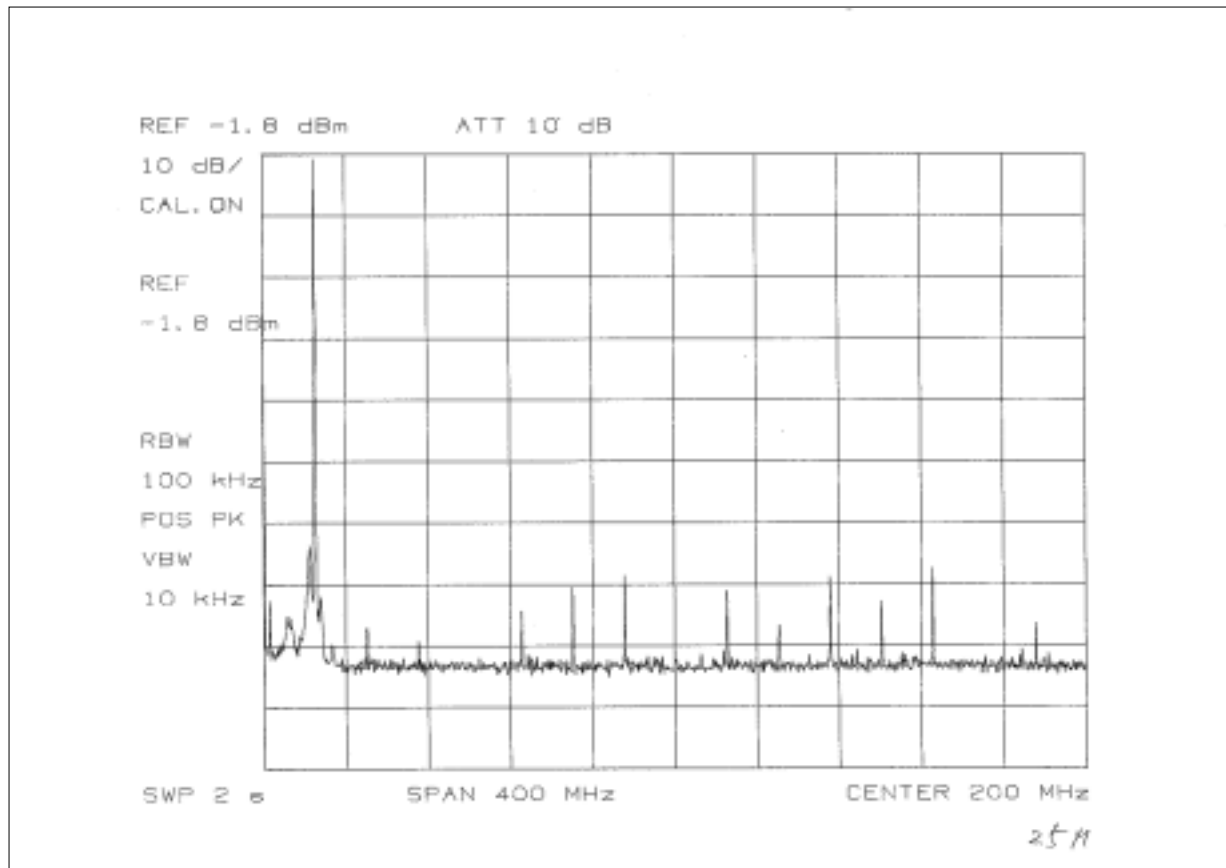

Fig. 3.5.24 - (Fc: 25700 kHz, J3E)

3.6 FIELD STRENGTH OF SPURIOUS RADIATION (FCC Rule Part 2.1053)

3.6.1 Method of Measurement

The transmitter is connected with measuring equipment as in Fig. 3.6.1.

Supplied with 24 VDC the transmitter is modulated with 2 audio tones 400 Hz and 1800 Hz in equal level. The input level is adjusted to 10 dB above the level producing PEP output of 150 W.

According to "Reference Data for Radio Engineers", fourth edition, ITT:

Power density P at a distance R (meters) due to power Pt emitted from an isotropic antenna in free space is expressed:

$$P = Pt/4R^2 \text{ (W/m}^2\text{)}$$

Power density expressed in field strength E (V/m) is at any point:

$$P = E^2/120$$

where 120 is a resistance value of free space.

Therefore,

$$\begin{aligned} E &= (120 P)^{1/2} \\ &= (120 Pt/4R^2)^{1/2} \\ &= (30 Pt)^{1/2}/R \end{aligned}$$

Field strength due to PEP 150 W at a distance 10 m is:

$$\begin{aligned} E &= \sqrt{30 \times 150} / 10 \\ &= 6.7 \text{ (V/m)} \end{aligned}$$

$$\begin{aligned} \text{Put } 1 \text{ } \mu\text{V/m} &= 0 \text{ dB}\mu \\ 6.7 \text{ V/m} &= 136.5 \text{ dB}\mu \text{ (reference level)} \end{aligned}$$

With this reference level, field strength of spurious emitted from the FS-1570 is measured by Spectrum Analyzer.

Measurement is made for each test frequency within 9 kHz to 300 MHz, especially on harmonics of carrier frequency Fc, 456.5 kHz (Intermediate Frequency) and its harmonics, 72.4565 MHz (2nd LO frequency) and (72.4565 + Fc) MHz the level is recorded.

Measurement is made for each of 3 planes of the FS-1570 to search the plane where most spurious radiation is found.

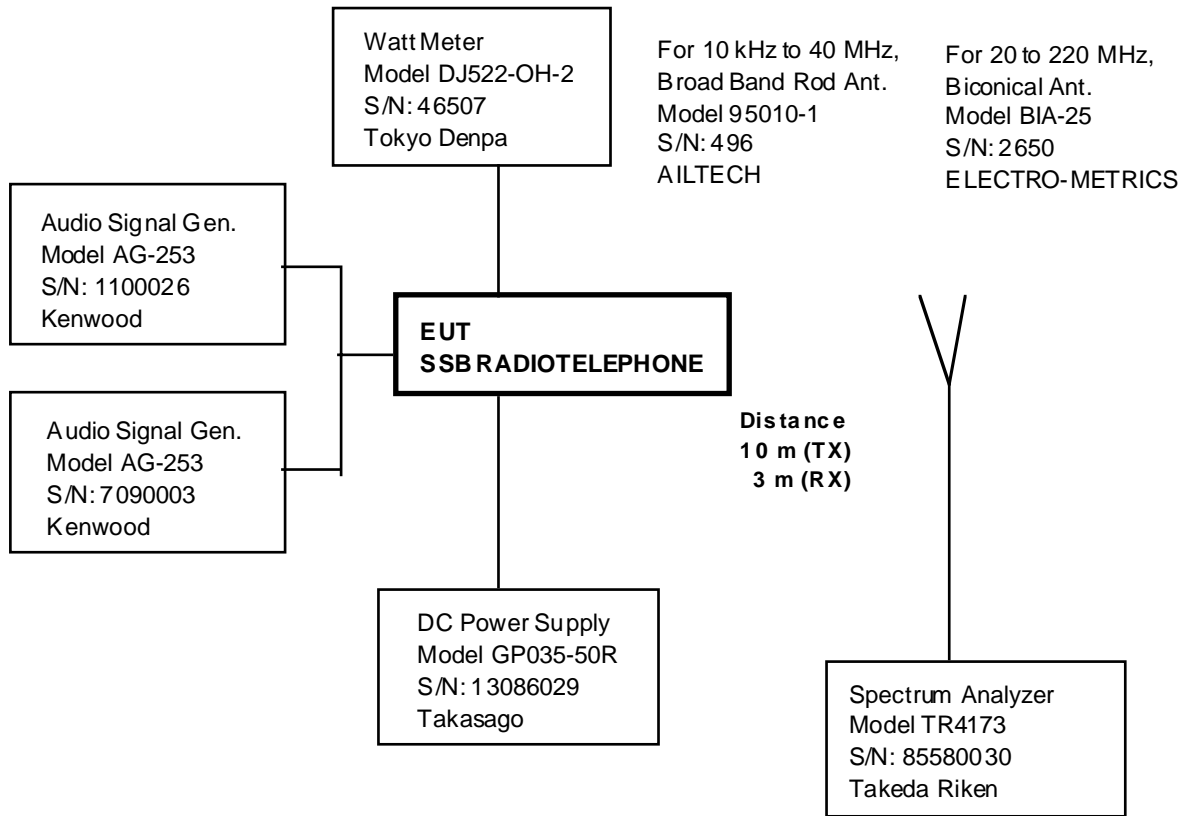

Fig. 3.6.1

Test Site:
Roof-top of 6 story building as always done for Marine Radar Measurements,
Furuno Electric Co., Ltd.

3.6.2 Test Result

Tables 3.6.1 through 3.6.10 show the results.

Table 3.6.1

Fc:1605.0 kHz

Spurious Frequency	Cabinet Radiation below Reference Level
2 × Fc	None detected to 120 dB
3 × Fc	
4 × Fc	
5 × Fc	
6 × Fc	
7 × Fc	
8 × Fc	
9 × Fc	
10 × Fc	
456.5 kHz (3rd IF)	
913.0 kHz (2 × 3rd IF)	
72.0 MHz (2nd LO)	
72.4565 MHz (2nd IF)	
72.4565 + Fc MHz (1st LO)	

Table 3.6.2

Fc: 2182.0 kHz

Spurious Frequency	Cabinet Radiation below Reference Level
2 × Fc	None detected to 120 dB
3 × Fc	
4 × Fc	
5 × Fc	
6 × Fc	
7 × Fc	
8 × Fc	
9 × Fc	
10 × Fc	
456.5 kHz (3rd IF)	
913.0 kHz (2 × 3rd IF)	
72.0 MHz (2nd LO)	
72.4565 MHz (2nd IF)	
72.4565 + Fc MHz (1st LO)	

Table 3.6.3

Fc: 3023.0 kHz

Spurious Frequency	Cabinet Radiation below Reference Level
2 × Fc	None detected to 120 dB
3 × Fc	
4 × Fc	
5 × Fc	
6 × Fc	
7 × Fc	
8 × Fc	
9 × Fc	
10 × Fc	
456.5 kHz (3rd IF)	
913.0 kHz (2 × 3rd IF)	
72.0 MHz (2nd LO)	
72.4565 MHz (2nd IF)	
72.4565 + Fc MHz (1st LO)	

Table 3.6.4

Fc: 4065.0 kHz

Spurious Frequency	Cabinet Radiation below Reference Level
2 × Fc	None detected to 120 dB
3 × Fc	
4 × Fc	
5 × Fc	
6 × Fc	
7 × Fc	
8 × Fc	
9 × Fc	
10 × Fc	
456.5 kHz (3rd IF)	
913.0 kHz (2 × 3rd IF)	
72.0 MHz (2nd LO)	
72.4565 MHz (2nd IF)	
72.4565 + Fc MHz (1st LO)	

Table 3.6.5

Fc: 8195.0 kHz

Spurious Frequency	Cabinet Radiation below Reference Level
$2 \times F_c$, $3 \times F_c$, $4 \times F_c$, $5 \times F_c$, $6 \times F_c$, $7 \times F_c$, $8 \times F_c$, $9 \times F_c$, and $10 \times F_c$	None detected to 120 dB
456.5 kHz (3rd IF)	
913.0 kHz (2 × 3rd IF)	
72.0 MHz (2nd LO)	
72.4565 MHz (2nd IF)	
72.4565 + Fc MHz (1st LO)	

Table 3.6.6

Fc: 12230.0 kHz

Spurious Frequency	Cabinet Radiation below Reference Level
$2 \times F_c$, $3 \times F_c$, $4 \times F_c$, $5 \times F_c$, $6 \times F_c$, $7 \times F_c$, $8 \times F_c$, $9 \times F_c$, and $10 \times F_c$	None detected to 120 dB
456.5 kHz (3rd IF)	
913.0 kHz (2 × 3rd IF)	
72.0 MHz (2nd LO)	
72.4565 MHz (2nd IF)	
72.4565 + Fc MHz (1st LO)	

Table 3.6.7

Fc: 16360.0 kHz

Spurious Frequency	Cabinet Radiation below Reference Level
$2 \times F_c$, $3 \times F_c$, $4 \times F_c$, $5 \times F_c$, $6 \times F_c$, $7 \times F_c$, $8 \times F_c$, $9 \times F_c$, and $10 \times F_c$	None detected to 120 dB
456.5 kHz (3rd IF)	
913.0 kHz (2 × 3rd IF)	
72.0 MHz (2nd LO)	
72.4565 MHz (2nd IF)	
72.4565 + Fc MHz (1st LO)	

Table 3.6.8

Fc: 18780.0 kHz

Spurious Frequency	Cabinet Radiation below Reference Level
$2 \times F_c$, $3 \times F_c$, $4 \times F_c$, $5 \times F_c$, $6 \times F_c$, $7 \times F_c$, $8 \times F_c$, $9 \times F_c$, and $10 \times F_c$	None detected to 120 dB
456.5 kHz (3rd IF)	
913.0 kHz (2 × 3rd IF)	
72.0 MHz (2nd LO)	
72.4565 MHz (2nd IF)	
72.4565 + Fc MHz (1st LO)	

Table 3.6.9

Fc: 22000.0 kHz

Spurious Frequency	Cabinet Radiation below Reference Level
$2 \times F_c$, $3 \times F_c$, $4 \times F_c$, $5 \times F_c$, $6 \times F_c$, $7 \times F_c$, $8 \times F_c$, $9 \times F_c$, and $10 \times F_c$	None detected to 120 dB
456.5 kHz (3rd IF)	
913.0 kHz (2 × 3rd IF)	
72.0 MHz (2nd LO)	
72.4565 MHz (2nd IF)	
72.4565 + Fc MHz (1st LO)	

Table 3.6.10

Fc: 25070.0 kHz

Spurious Frequency	Cabinet Radiation below Reference Level
$2 \times F_c$, $3 \times F_c$, $4 \times F_c$, $5 \times F_c$, $6 \times F_c$, $7 \times F_c$, $8 \times F_c$, $9 \times F_c$, and $10 \times F_c$	None detected to 120 dB
456.5 kHz (3rd IF)	
913.0 kHz (2 × 3rd IF)	
72.0 MHz (2nd LO)	
72.4565 MHz (2nd IF)	
72.4565 + Fc MHz (1st LO)	

3.7 FREQUENCY STABILITY (FCC Rule Part 2.1055)

3.7.1 Method of Measurement

The FS-1570 stored in the chamber, is connected with measuring equipment as in Fig. 3.7.1.

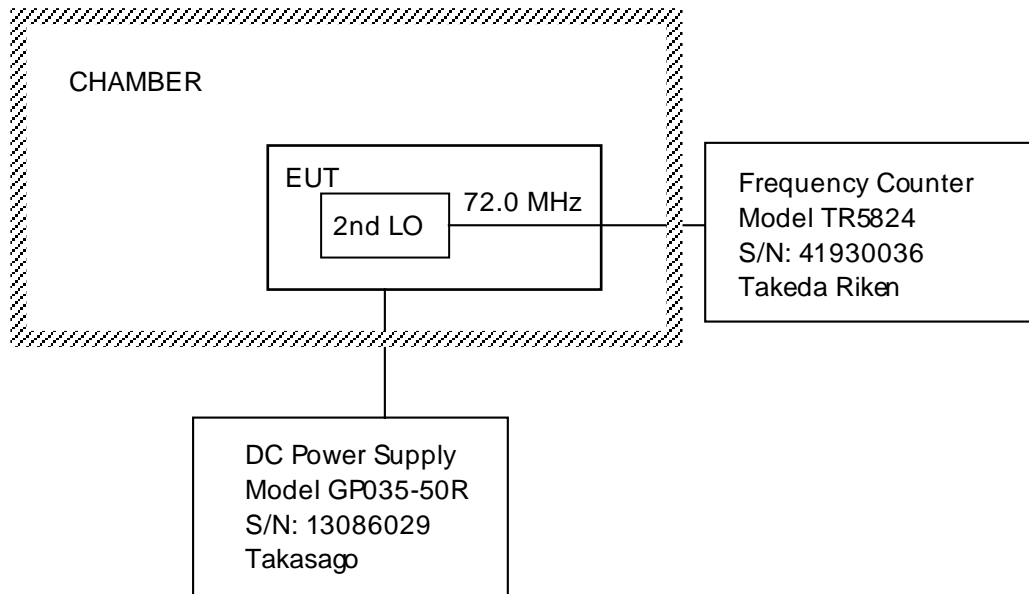

Fig. 3.7.1 Test set-up for Frequency Stability Measurements

With the power switch off, the FS-1570 is left in the chamber until thermal equilibrium is achieved. Power is then applied and, after 15 minutes of warm-up, the reference oscillator frequency is measured. Measurements are made within the temperature range -30°C to $+50^{\circ}\text{C}$ at 10°C interval, by applying 85 % (20.4 V), 100% (24 V), and 115% (27.6V) of the rated DC power supply voltage.

Frequency stability measurements are also performed in cold start conditions (no warm-up period). For the purpose of these measurements, change in the reference oscillator frequency is plotted in the function of the lapse of time up to 60 minutes. The FS-1570 is tested at -30°C , -20°C , 0°C and $+30^{\circ}\text{C}$.

3.7.2 Test Result

The results are shown in Fig. 3.7.2 to 3.7.4, and Fig. 3.7.5 to 3.7.8, respectively.

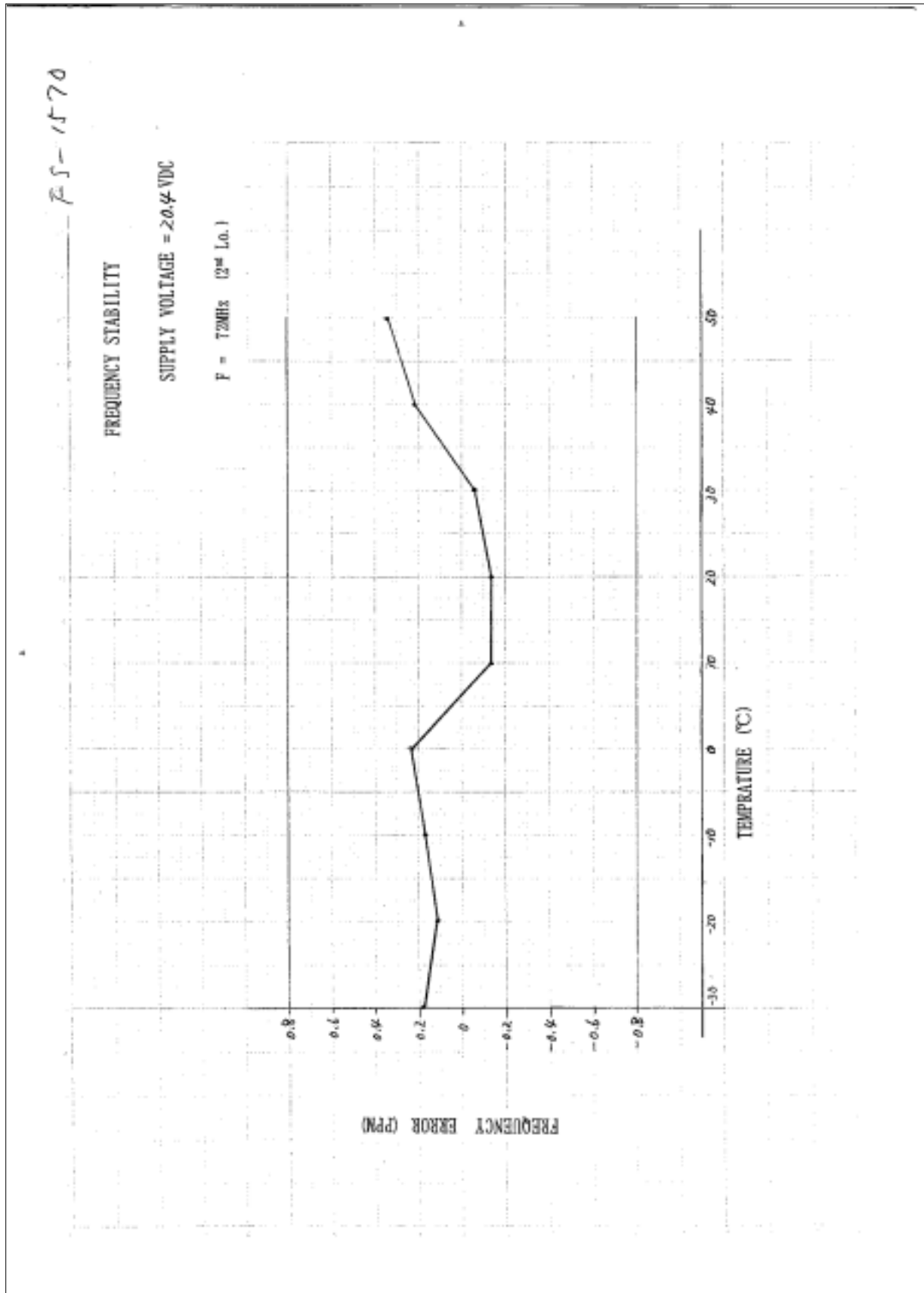

Fig. 3.7.2 - Temperature vs. Frequency error (for Power supply voltage: 20.4 VDC)

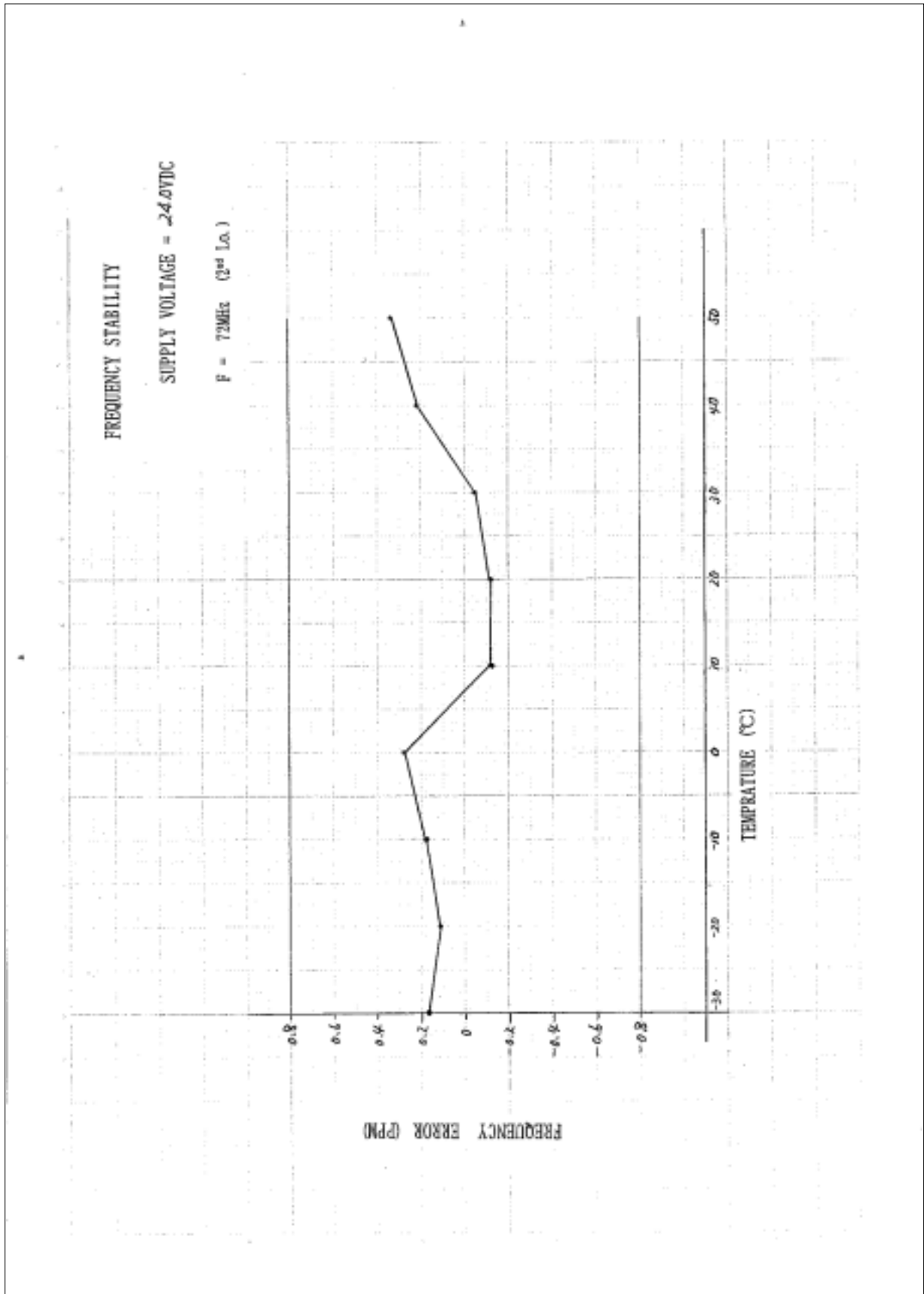

Fig. 3.7.3 - Temperature vs. Frequency error (for Power supply voltage: 24.0 VDC)

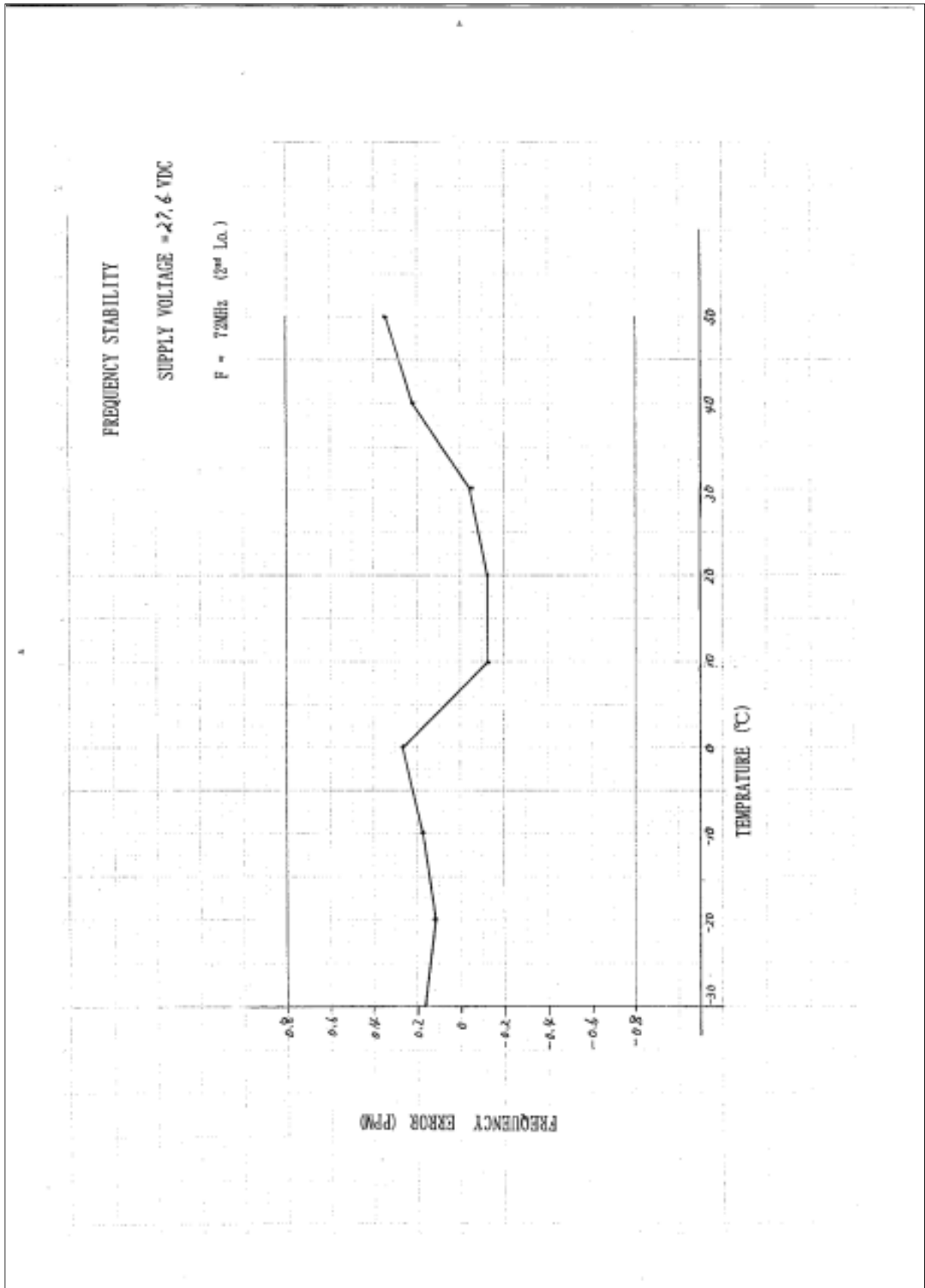

Fig. 3.7.4 - Temperature vs. Frequency error (for Power supply voltage: 27.6 VDC)

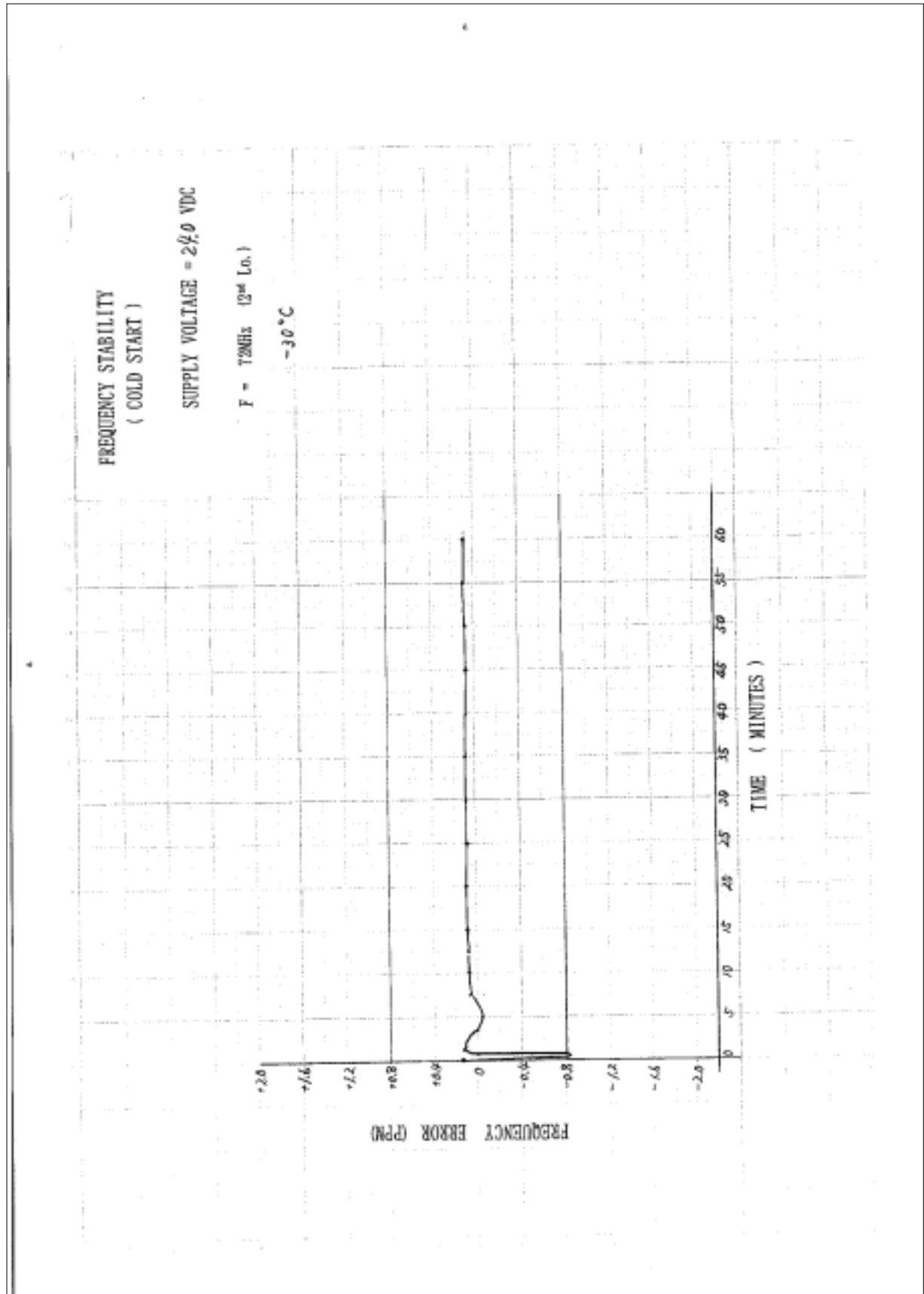

Fig. 3.7.5 - Lapse of time vs. Frequency error (at -30°C)

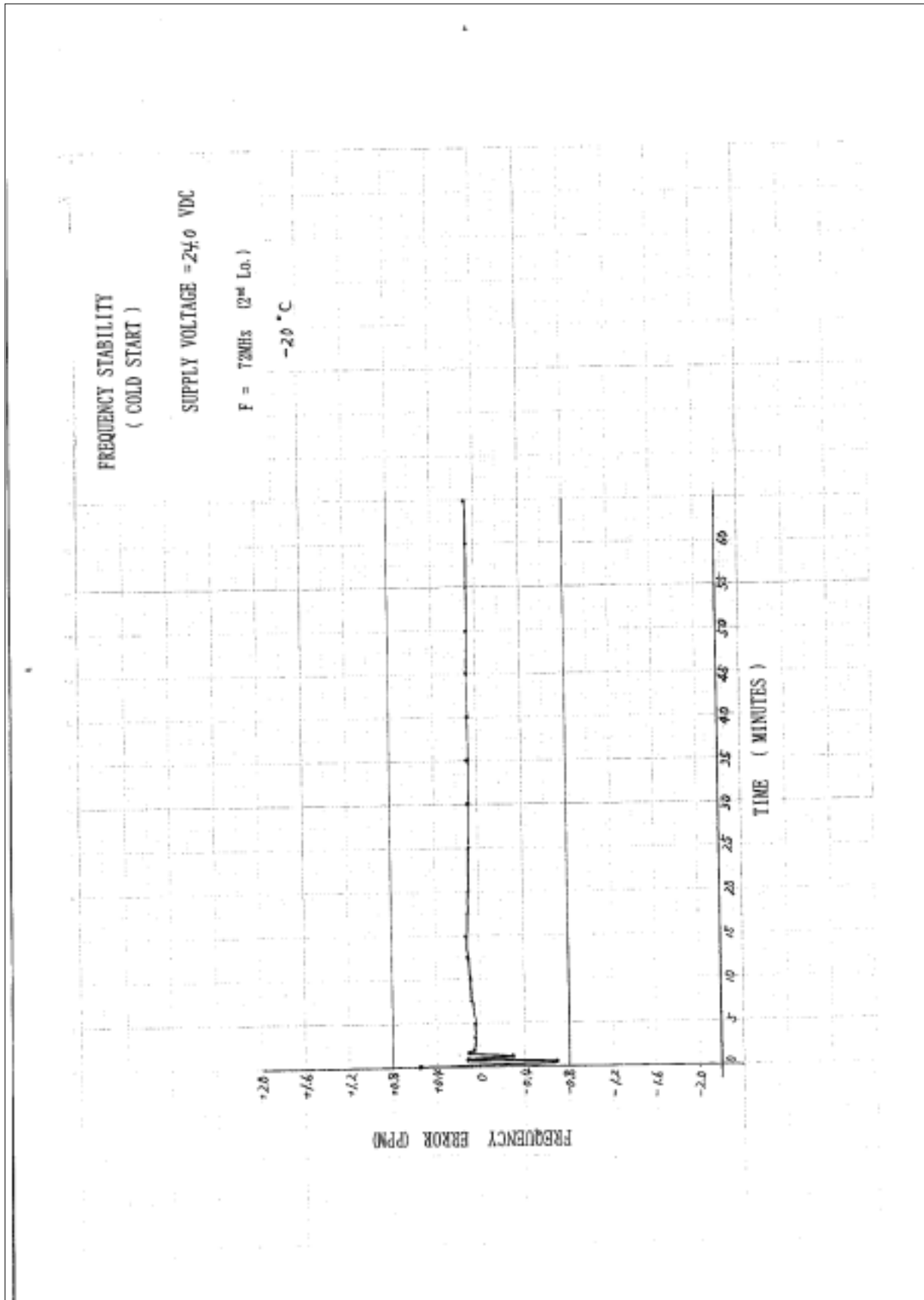

Fig. 3.7.6 - Lapse of time vs. Frequency error (at -20°C)

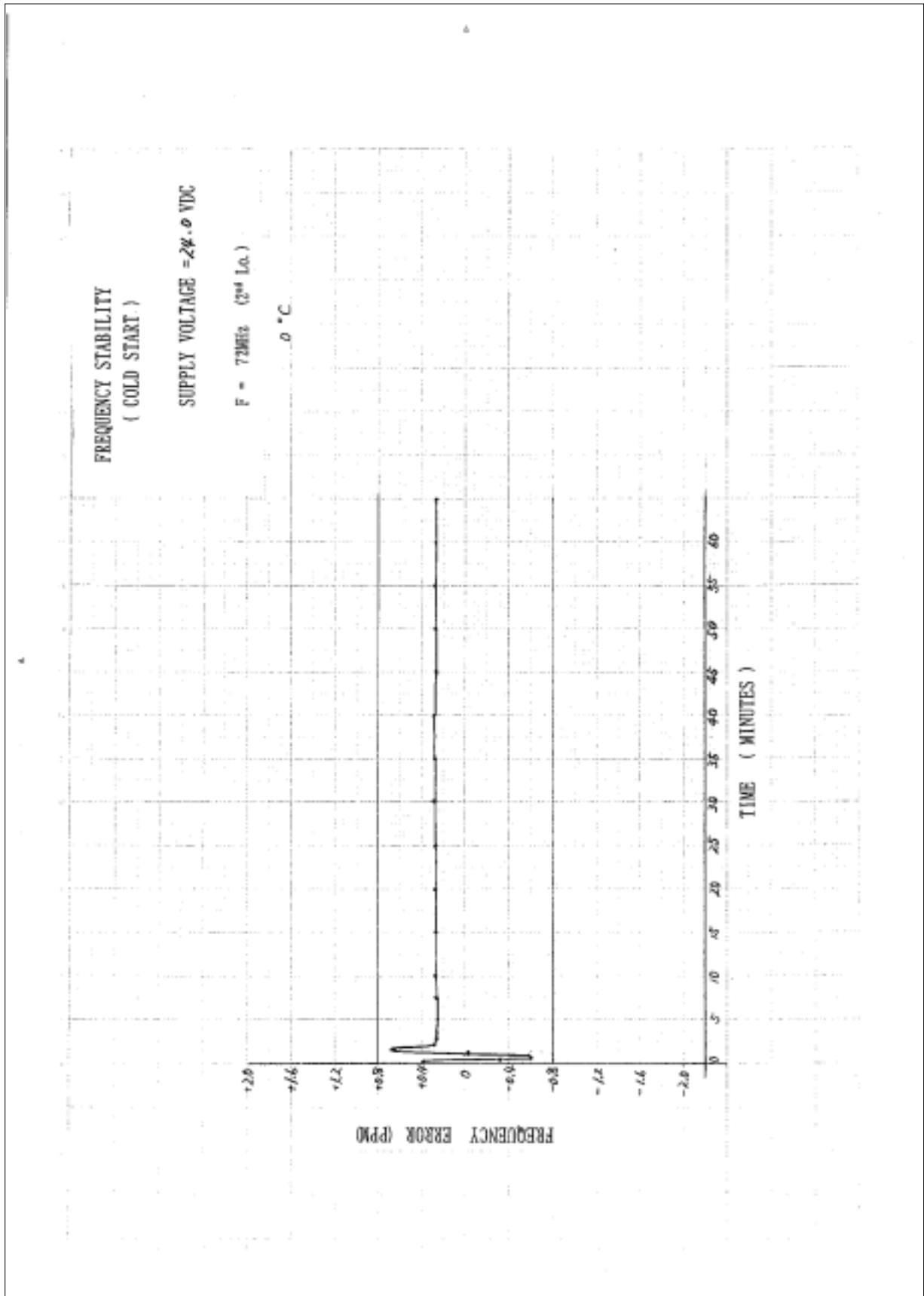

Fig. 3.7.7 - Lapse of time vs. Frequency error (at 0°C)

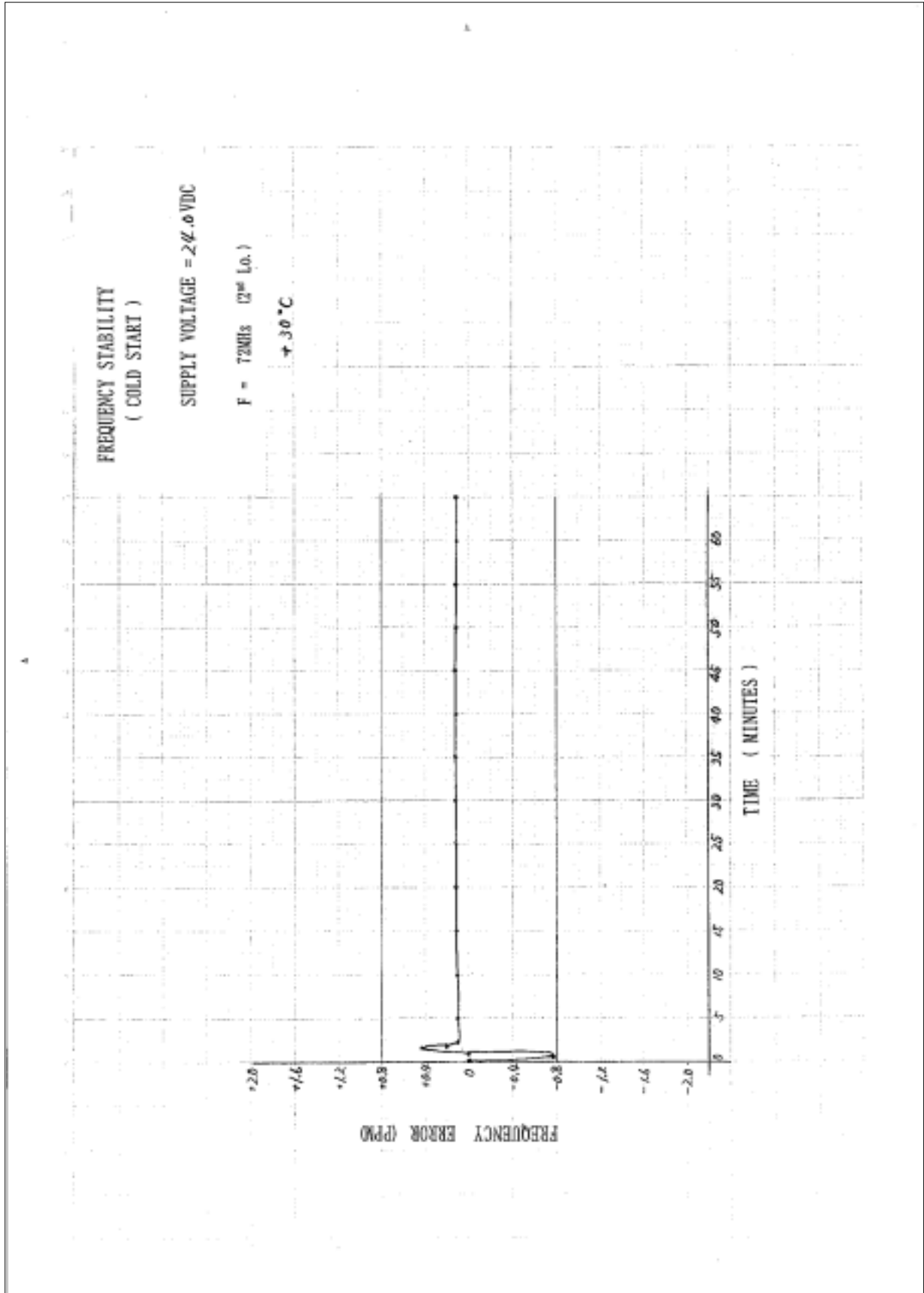

Fig. 3.7.8 - Lapse of time vs. Frequency error (at +30°C)

3.8 SUPPRESSION OF INTERFERENCE FROM RECEIVER (FCC Rules Part 80.217 and 2.1051)

3.8.1 Method of Measurement

Cabinet radiation is measured by the same setup with Fig. 3.6.1, and the distance between the FS-1570 and the receiving antenna is set to 3 meters to expand dynamic range.

3.8.2 Test Result

3.8.2.1 Cabinet radiation

The results are shown in Table 3.8.1.

Table 3.8.1

Frequency Range	Measurement results at 3 m	Converted to 1 m	Limit (at 1 m)
9 kHz - 30 MHz	Less than Instrument's noise level: Less than 16 dB μ (6 μ V/m)	Less than 0.01 μ V/m	0.1 μ V/m
30 - 100 MHz	Less than Instrument's noise level: Less than 35 dB μ (56 μ V/m)	Less than 0.09 μ V/m	0.3 μ V/m
100 - 300 MHz	Less than Instrument's noise level: Less than 35 dB μ (56 μ V/m)	Less than 0.09 μ V/m	1.0 μ V/m

3.8.2.2 Spurious emission at receiver antenna terminal

(FCC Rule Part 2.1051)

The results are shown in Table 3.8.2.

Table 3.8.2

Frequency Range	Measurement results
9 kHz - 30 MHz	Less than Instrument's noise level: Less than -85 dBm (3 pW)
30 - 100 MHz	Less than Instrument's noise level: Less than -85 dBm (3 pW)
100 - 300 MHz	Less than Instrument's noise level: Less than -85 dBm (3 pW)

4 TRANSMITTER POWER ADJUSTMENT PROCEDURE (FCC Rule part 2.1033)

4.1 Set-up

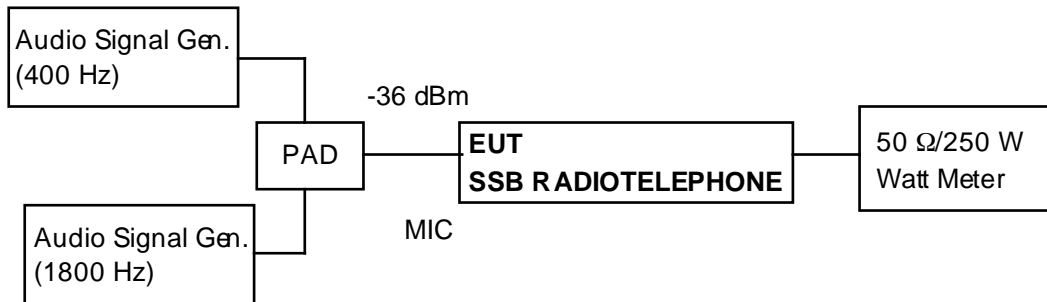

Fig. 4.1.1

4.2 Procedure

- (a) Set transmit frequency to ITU 401 and select SSB as class of emission.
- (b) Apply two tones simultaneously at frequencies of 400 Hz and 1800 Hz with equal amplitudes to MIC input of FS-1570 at a level of -36 dBm.
- (d) Key the transmitter and adjust R76 (ALC) on B07 05P0736 TX-FIL Board to obtain 150 W_{pep}.

**5 PHOTOGRAPHS TO REVEAL EQUIPMENT CONSTRUCTION
 AND LAYOUT (FCC Rule Part 2.1033)**

(See separate cover.)

6 DESCRIPTION OF CIRCUITRY AND DEVICES (FCC Rule Part 2.1033)

6.1 Function of Each Semiconductor or Active Device

(1) Antenna Coupler unit AT-1560-15

COUP Board: 05P0528

<u>Symbol</u>	<u>Component</u>	<u>Type</u>	<u>Function</u>
Q0001	TR	2SC2498	RF AMP
Q0002	TR	2SA1020-Y	CPU VCC CONTROL
Q0003	TR	2SC1815-Y	CPU VCC CONTROL
U0001	MOS LOGIC	TC74HC390AP	RF SIGNAL COUNTER
U0002	IC	μPD7001C	A/D CONVERTER
U0003	MOS MPU	TC74HC14AP	CONTROL
U0004	IC	M51953BL	RESET CONTROL
U0005	IC	AN6705F	5 V REGULATOR
U0006	IC	NJM2403D	P.D. CHECK
U0008	MOS MPU	05S0522-0	CPU
U0009	IC	M54563P	RELAY DRIVE
U0010	IC	M54563P	RELAY DRIVE
U0011	IC	M54563P	RELAY DRIVE

DUMMY Board: 05P0543

None

(2) Transceiver unit FS-1570T

T-CPU Board: 05P0732

<u>Symbol</u>	<u>Component</u>	<u>Type</u>	<u>Function</u>
Q0001 - 0002	TR	DTC114EKAT146	RCV BZ CONT
Q0003 - 0004	TR	DTC114EKAT146	DMC CONT
U0001	IC	M51957BFP C61J	CPU RESET CONT
U0002	Ceramic Oscillator	CSTCS12.5MTA-TC	CLOCK OSC
U0003	MOS MPU	MB911101PF-G-BND-R	CPU
U0004	MOS FLA	MBM29F800TA-70PFTN	MEMORY
U0005	MOS EEPROM	AT28C256-20PC	MEMORY
U0006 - 0007	MOS SRAM	K6T1008C2E-GB70T	MEMORY
U0008	MOS MPU	M38881M2-153GP	CPU
U0009	Ceramic Oscillator	CSTCS12.5MTA-TC	CLOCK OSC
U0010	IC	AM26LS31CNSR	RS422 DRIVER

U0011	MOS LGC	TC74HC14AF-EL	DATA DRIVER
U0012	IC	TLP181-GB-TPL	RCV BZ CONT
U0013 - 0014	IC	SN75LBC179DR	RS422 DRIVER
U0015	MOS MPU	M38881M2-153GP	CPU
U0016	Ceramic Oscillator	CSTCS12.5MTA-TC	CLOCK OSC
U0017	MOS LGC	TC74HC14AF-EL	DATA DRIVER
U0018 - 0020	IC	PC400	SERIAL DATA DRIVER
U0021	MOS	LT1080CSW	RS232 DRIVER
U0022 - 0024	MOS	TC74HC390AF	CLOCK DRIVER
U0028	IC	MB3790PFT	BACKUP CONT
U0029	MOS CLOCK	RTC-62423 L2	RTC
U0030	MOS LGC	TC74HC139AF-EL	ADDRESS CONT
U0031- 0032	MOS LGC	TC74HC541AF-EL	DATA BUFF
U0033 - 0035	IC	M5218AFP-600C	LINE AMP
U0036 - 0037	MOS LGC	TC4066BFN-EL	LINE SELECT
U0038	IC	M54972FP-30ND	LINE SELECT CONT
U0039	DC-DC Converter	SI-8301L	5 V AVR
U0040	IC	μPC1093T-E1	REF. VOLT
U0041	IC	TLP181-GB-TPL	DMC CONT
U0042	MOS	LTC1484CS8	RCV. BZ. CONT
U0043	IC	TA77808F-TE16L	8 V AVR

DSP (For DSC & NBDP) Board: 05P0751

<u>Symbol</u>	<u>Component</u>	<u>Type</u>	<u>Function</u>
U0001	IC	AD1819BJST	CODEC
U0002	MOS DSP	ADSP-2181KST-115	DSP
U0003	MOS FLA	MBM29F400BC-90PFTN	MEMORY
Y0001	XTAL Oscillator	HC-49/U 5.1200 MHz	CODEC CLOCK OSC
Y0002	XTAL Oscillator	HC-49/U 11.8040 MHz	DSP CLOCK OSC

TX/RX Board: 05P0733

<u>Symbol</u>	<u>Component</u>	<u>Type</u>	<u>Function</u>
Q0001 - 0002	FET	PMBFJ310	RX RF AMP
Q0003 - 0004	FET	PMBFJ310	MIXER
Q0005	TR	2SC2954-T1	TX RF AMP
Q0006	TR	2SC3133	TX RF AMP
Q0007	TR	2SC2712-Y-TE85L	AGC BUFF AMP
Q0008	TR	2SC2712-Y-TE85L	RX IF BUFF AMP
Q0009	TR	2SC2712-Y-TE85L	3RD LO. BUFF AMP

Q0010	TR	2SC2712-Y-TE85L	TX IF BUFF AMP
Q0011 - 0012	TR	DTA114EKAT146	MODE CONT
Q0013 - 0015	TR	DTB143EKT146	T/R CONT
Q0016	TR	DTC114EKAT146	NB CONT
Q0017 - 0018	TR	DTA114EKAT146	MODE CONT
Q0021	TR	2SC3123	BUFF AMP
Q0022	TR	2SK879-Y TE85L	CHARGE PUMP
Q0023	TR	2SC1622A-L	CHARGE PUMP
Q0024	FET	2SK210-GR TE85L	VCO
Q0025 - 0027	MOS FET	2SK882-GR TE85L	BUFF AMP
Q0028	TR	2SC3518-Z-T1	NOISE FILTER
Q0029	MOS FET	2SK882-GR-TE85L	TEST SIG. BUFF
Q0030	MOS FET	2SK882-GR-TE85L	REF OSC BUFF
Q0031	TR	2SC3123	CLOCK BUFF
Q0032	TR	2SC3123	X2 DOUBLER
Q0033	TR	DTC114EKAT146	
Q0034	TR	DTB143EKT146	T/R CONT
Q0035	FET	2SK210-GR TE 85L	RX 1ST IF AMP
Q0037	TR	2SC3123	TX IF AMP
Q0038	TR	2CS2712-Y-TE85L	RX 2ND IF AMP
Q0039	TR	DTC114EKAT146	T/R CONT
U0001 - 0002	MOS LGC	TC74HC595AF	SIFT REGISTER
U0003	MOS LGC	TC74HC595AF	ALC POWER CONT
U0004	MOS LGC	TC74HC595AF	RX PF GAIN CONT
U0005 - 0006	IC	M54972FP-30NA	PRE-SELECTOR CONT
U0007	IC	M54972FP-30NA	TX/RX MODE CONT
U0008	IC	M54972FP-30NA	AGC CONT
U0009	MOS LGC	TC4051BFN	Self Test Signal Cont
U0010	IC	μPC1675G-T1	RX 1ST LO. BUFF AMP
U0011	IC	μPC1675G-T1	TX 1ST LO. BUFF AMP
U0012	IC	μPC1675G-T1	2ND LO BUFF AMP
U0013	IC	AD603AR	1ST IF AGC AMP
U0014	IC	NJM1496V-TE1	2ND MIX.
U0015	NB DET	05P0448	NOISE BLANKER
U0016	IC	NJM1496V-TE1	TX 2ND MIX.
U0018	IC	NJM1496V-TE1	TX 3RD MIX.
U0019	IC	AD603AR	TX ALC AMP
U0020 - 0021	IC	NJM2904M-T1	TX ALC CONT
U0022 - 0023	MOS LGC	TC4066BFN-EL	IF FILTER SELECT

U0024	MOS LGC	TC4066BFN-EL	AGC CONT
U0025	IC	AD605AR-REEL	RX 2ND IF AMP
U0027	IC	NJM4558M-T1	AGC CONT
U0028	IC	NJM2904M-T1	RF Gain Cont/S Meter Amp
U0029	IC	NJM2904M-T1	RX.AF AMP
U0030	IC	NJM1496V-TE1	TX 1AT MIX
U0031	IC	NJM1496V-TE1	AF ALC AMP
U0032	IC	AN6123MS-TXL	RX 3RD MIX
U0033	IC	TA7812F-TE16L	12V AVR
U0034	IC	TA7805F-TE16L	5V AVR
U0042	MOS	AD9832BRU	Direct Digital Synthesizer
U0043	MOS	MC145170D2	PLL
U0044	IC	M54972FP-30NA	VCO BAND SELECT
U0045	MOS	AD9832BRU	DDS
U0046	IC	μPC1675G-T1	REF. OSC BUFF AMP
U0047	MOS LGC	TC74HC02AF-EL	

PRESEL Board: 05P0746

NONE

REF OSC Board: 05P0747

<u>Symbol</u>	<u>Component</u>	<u>Type</u>	<u>Function</u>
U0001	IC	NJM2904M-T1	OVEN CONT
U0002	IC	μPC1675G-T1	REF OSC. BUFF AMP
Y0001	XTAL Oscillator	NTO-801BS 18 MHZ	REF. OSC

W/R Board: 05P0734

<u>Symbol</u>	<u>Component</u>	<u>Type</u>	<u>Function</u>
CR0004	DIODE	DSM10C-TR	RECT
CR0005	DIODE	DSM10C-TR	RECT
CR0006	DIODE	SMS3927-023	SB
CR0008 - 0011	DIODE	1SS356TW11	Switching
CR0502 - 0505	DIODE	1SS356TW11	Switching
CR0506 - 0509	DIODE	1SV232-TPH4	VC
FL0001	XTAL Filter	54M8B1	Filter
FL0002	XTAL Filter	SF0L03K	Filter
FL0501 - 0502	Ceramic Filter	SFSA6M00CF0B0	Filter
FL0503	Ceramic Filter	CFULB455KE4A-B0	Filter
Q0002 - 0003	FET	PMBFJ310	RX RF AMP

Q0004	FET	2SK210-GR TE85L	1ST IF AMP
Q0005	TR	2SC3123	1ST LO BUFF AMP
Q0007	TR	2SC2712-Y-TE85L	3RD LO BUFF AMP
Q0501	TR	2SC3123	BUFF AMP
Q0502	TR	2SK879-Y TE85L	CHARGE PUMP
Q0503	TR	2SC1622A-L	CHARGE PUMP
Q0504	FET	2SK210-GR-TE85L	VCO
Q0505 - 0507	MOS FET	2SK882-GR-TE85L	BUFF AMP
Q0508	TR	2SC3518-Z-T1	NOISE FIL
Q0509	MOS FET	2SK882-GR-TE85L	REF OSC BUFF AMP
Q0510	TR	2SC3123	BUFF AMP
Q0511	TR	2SC3123	2nd LO BUFF AMP
Q0512	MOS FET	2SK882-GR-TE85L	TEST SIG. SW
Q0514	TR	DTC114EKAT146	TEST SIG. SW CONT

T-IF Board: 05P0731

<u>Symbol</u>	<u>Component</u>	<u>Type</u>	<u>Function</u>
Q0001	TR	DTC114EKAT146	ANT COUP CONT
Q0002	TR	DTC114EKAT146	MUTE SW CONT
Q0004	TR	2SD1409A	BK CONT
Q0005	TR	DTC114EKAT146	LINE SELECT
Q0006 - 0007	TR	DTC114EKAT146	TX KEY CONT
U0001	IC	TA7805F-TE16L	5 V AVR
U0002 - 0003	MOS LGC	TC74HC595AF	SIFT REGISTER
U0004	IC	M54972FP-30NA	LINE CONT
U0005	IC	M54972FP-30NA	ANT COUP. CONT
U0006	MOS LGC	TC4051BFN	ANT COUP. CONT
U0007	MOS LGC	TC4053BFN	LINE SELECT
U0008	MOS LGC	TC4066BFN-EL	LINE SELECT
U0009 - 0010	IC	M5218AFP-600C	LINE AMP
U0011	IC	NJM386M-T1	LINE AMP
U0012	MOS LGC	TC74HC02AF-EL	SIFT REGISTER CONT
U0013	IC	TLP121-GB-TPR	RX MUTE CONT
U0014	IC	TLP121-GB-TPR	BK CONT

PA Board: 05P0735

<u>Symbol</u>	<u>Component</u>	<u>Type</u>	<u>Function</u>
Q0001 - 0002	TR	2SC3133	TX RF DRIVE AMP
Q0003 - 0004	TR	SD1407	TX RF POWER AMP

Q0005	TR	2SD1271A-P	PA BIAS CONT
Q0006	TR	2SA1315-Y	PA BIAS CONT
Q0007	TR	2SC1212AV-C	PA BIAS CONT
Q0008	TR	2SD1271A-P	15 V AVR
Q0009 - 0010	TR	2SC1815-Y-TPE2	VC CHECK CONT
Q0011 - 0012	TR	2SC1815-Y-TPE2	IC CHECK CONT
U0001	IC	NJM2904D	IC CHECK CONT
U0002	IC	PC817X1	PA BIAS CONT
U0003	IC	TLP531BL	IC CHECK CONT
U0004	IC	TLP531BL	VS CHECK CONT

TX-FIL Board: 05P0736

<u>Symbol</u>	<u>Component</u>	<u>Type</u>	<u>Function</u>
Q0002	TR	DTA114EKAT146	Power Amp Bias Cont
Q0001	TR	DTA114EKAT146	Driver Amp Bias Cont
Q0003 - 0004	FET	PMBFJ310	RCVER RF AMP
U0001 - 0002	MOS LGC	TC74HC595AF	RELAY SELECT
U0003	IC	M54972FP-30ND	RELAY SELECT
U0004	IC	M54972FP-30ND	RELAY SELECT
U0005 - 0006	MOS LGC	TC4051BFN	CHECK SIG. SELECT
U0007	IC	TD62787AF	RELAY DRV.
U0008	IC	NJM2904M-T1	ALC AMP
U0009	IC	TA7805F-TE16L	5 V AVR
U0010	MOS LGC	TC74HC02AF-EL	DATA CONT

SW REG Board: 05P0737

<u>Symbol</u>	<u>Component</u>	<u>Type</u>	<u>Function</u>
CR0002	DIODE	FML-22S	RECT.
Q0001	TR	2SB941-P	18 V AVR.
Q0002	TR	2SD667A-C	18 V AVR.
Q0004	MOS FET	2SK1432	SW REG DRIVE
U0001	IC	FA5504P	SW REG CONTROL
U0002	IC	µPC1093J	REF. VOLT
U0003	IC	TLP521-1GB	REF. CHECK

RELAY Board: 05P0744

<u>Symbol</u>	<u>Component</u>	<u>Type</u>	<u>Function</u>
Q0001 - 0002	TR	DTB143ESTP	RELAY CONT

Q0003	TR	2SC3518-Z-T1	12 V AVR
Q0004	TR	DTD143EKT146	RELAY DRIVE
Q0005	TR	DTC114EKAT146	LOW VOLT PROTECT
Q0006	TR	DTC114EKAT146	HI VOLT PROTECT
Q0007	TR	DTC114EKAT146	RELAY DRIVE

(3) Control Unit FS-2570C

C-IF Board: 05P0730

<u>Symbol</u>	<u>Component</u>	<u>Type</u>	<u>Function</u>
CR0005	DIODE	RM4Z-015-304	Protection from reverse connection
Q0001	TR	2SA1385-Z	POWER ON/OFF CONT
Q0002	TR	2SC1622-L	POWER ON/OFF CONT
Q0003	FET	2SJ144-GR-TE85L	MUTE SW
Q0004	TR	DTC114EKAT146	SQ. SIG DRIVER
Q0005 - 0006	TR	DTC114EKAT146	LINE SW CONT
U0001	IC	M5218AFP-600C	MIC AMP
U0002	IC	AN6123MS-TXL	MIC ALC AMP
U0003	IC	M5218AFP-600C	PHONE AMP
U0004	IC	NJM082M-T1	SQL AMP
U0005	MOS LGC	TC4066BFN-EL	LINE SELECT
U0006	IC	M62429FP-780C	AF VR AMP
U0007	IC	TA7252AP	AF POWER AMP
U0008	IC	TLP121-GB-TPR	KEY CONT
U0009	IC	TLP121-GB-TPR	PTT CONT
U0010	IC	TLP121-GB-TPR	HOOK CONT
U0011	IC	TLP121-GB-TPR	POWER ON CONT
U0012	IC	TA7805F-TE16L	5 V AVR

C-CPU Board: 05P0729

<u>Symbol</u>	<u>Component</u>	<u>Type</u>	<u>Function</u>
Q0001 - 0005	TR	DTD143EKT146	LED DRIVER
U0001	IC	M51957BFP C61J	RESET CONTROL
U0002	Ceramic Oscillator	CSTCS12.5MTA-TC	CLOCK OSC
U0003	MOS MPU	MB91101PF-G-BND-R	CPU
U0004	MOS FLA	MBM29F800TA-70PFTN	MEMORY
U0005	MOS EEPROM	AT28C256-20PC	MEMORY
U0006 - 0007	MOS SRAM	K6T1008C2E-GB70T	MEMORY
U0008	MOS LGC	TC74HC541AF-EF	DATA BUFF
U0009	MOS Gate-array	LZ9GF18 KEY	LCD DRIVER

U0010	MOS MPU	M38881M2-153GP	CPU
U0011	Ceramic Oscillator	CSTCS12.5MTA-TC	CLOCK OSC
U0012	IC	SN75LBC179DR	RS422 DRIVER
U0013	MOS	LT1080CSW	RS232 DRIVER
U0014 - 0015	MOS LGC	TC74HC541AF-EF	PRINTER DRIVER
U0016	DC-DC Converter	SI-8301L	5 V AVR

PANEL Board: 05P0728

<u>Symbol</u>	<u>Component</u>	<u>Type</u>	<u>Function</u>
CR0025	Diode	PY1101W	KEY Illumination
Q0001	TR	2SA1312-BL	Power Sw/Driver
U0001	LCD	TZ6582302A	LCD UNIT
U0002	LED BLOCK	TZ6583553A	LCD Illumination

(4) Handset HS-2001

HS Board: 05P0745

<u>Symbol</u>	<u>Component</u>	<u>Type</u>	<u>Function</u>
CR0001	Diode	1SS272	Switching
Q0001	TR	DTC114EKA146	PTT Cont
U0001	IC (ALC)	AN6123MS	Mic Amp
U0002	IC (Op Amp)	M5218AFP	Mic Amp/Phone Amp
U0003	IC (P Amp)	NJM386M	Phone Amp
U0004	IC (Reg)	AN77L09M	9 V AVR
U0005	IC (Hall)	DN6848S	Hook SW

6.2 Description of the circuits employed for suppression of spurious radiation, for limiting or shaping the control pulse, and for limiting or controlling power

(See separate cover.)

**7 Operator's Manual incl. Circuit Diagrams (FCC Rule Part
2.1033)**

(See separate cover.)