

LABOTECH

Furuno Labotech International

Report no. : FLI 12-98-017

All tests were performed in Furuno Labotech International Co., Ltd.

All data herein contained is true and correct to our best knowledge.

All tests were performed by:

name : Katsumi Imamura

function : Test engineer

signature : 

Review and report by:

name : Toshiro Segawa

function : QA manager

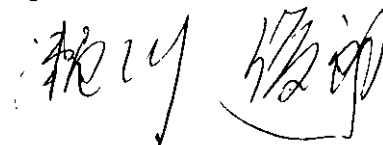
signature : 

This report has been verified and approved by:

date : December 26, 1998

name : Sadatomo Kuwahara

function : Manager Engineering Section

signature : 

*** * * * * C O N T E N T S * * * * ***

1 General Information.....	4
2 Identification of Equipment (FCC Rule § 2.925).....	10
3 RF Power Output (FCC Rule § 2.985).....	11
4 Modulation Characteristics (FCC Rule § 2.987)	14
5 Occupied Bandwidth (FCC Rule § 2.989)	22
6 Spurious Emissions at Antenna Terminal (FCC Rule § 2.991).....	24
7 Field Strength of Spurious Radiation (FCC Rule § 2.993)	28
8 Frequency Stability (FCC Rule § 2.995)	30
9 Suppression of Interference Aboard Ships (FCC Rule § 80.217)	33
10 Photographs to Reveal Equipment Construction and Layout (FCC Rule § 2.983)...	37
11 Technical Description of Equipment (FCC Rules § 2.983).....	47
11.1 Function of Each Semiconductor or Active Device (FCC Rule § 2.983 (d)-(6)).....	47
11.2 Description of the Circuits Employed for Suppression of Spurious Radiation, for Limiting or Shaping the Control Pulse, and for Limiting or Controlling Power	52
12 Operator's Manual Incl. Circuit Diagrams (FCC Rule § 2.983)	57
 Attachment 1 [Test data for <u>6. Spurious Emissions at Antenna Terminal</u>]	 A1
Attachment 2 [Test data for <u>7. Field Strength of Spurious Radiation</u>]	A2
Attachment 3 [Test data for <u>9. Suppression of Interference Aboard Ships</u>]	A3
Attachment 4 [List of Test/Measuring Equipment]	A4

(e) Pulse Characteristics:

Range Scale (nm)	(Short)	(Middle 1)	(Middle 2)	(Long 1)	(Long 2)
	<u>0.125</u>				
	0.25				
	0.5				
	0.75 (*)	0.75 (*)			
	1.0 (*)	1.0 (*)			
	1.5 (*)	1.5 (*)			
	2 (*)	2 (*)			
	3 (*)	<u>3 (*)</u>			
		4 (*)	4 (*)		
		6 (*)	6 (*)		
		8 (*)	8 (*)	8 (*)	
		12 (*)	<u>12 (*)</u>	12 (*)	
			16 (*)	16 (*)	
			24 (*)	24 (*)	
				32	
				<u>48</u>	
				72	
				96	
					<u>120</u>
Output pulselength (_ s)	0.08	0.20	0.60	1.20	1.20
P.R.R. (Hz)	1900	1100	600	600	450
Duty cycle	1.52E-4	2.20E-4	3.60E-4	7.20E-4	5.40E-4
Guard Band (MHz)	18.75	7.50	2.50	1.25	1.25

Note 1:(*) - Two (2) pulse types are selectable for each Range Scale.

2: Tests were carried out for the underlined Range Scales.

1.3 Modulator

- (a) Thyristor Type: SH16J12U
 Trigger Voltage: Approx. +12 VDC positive

1.4 Receiver

- (a) Passband

RF Stage: 100 MHz

IF Stage:

Pulselength	Short	Middle 1	Middle 2	Long 1	Long 2
(MHz)	27	27	3	3	3

Video Amp. : 14 MHz

- (b) Gain (overall) (dB): Sufficient to cause limiting, approximately 130
- (c) Overall Noise Figure (dB): 4 (typical)
- (d) Video Output Voltage (V): 0.7 positive across 75 ohms
- (e) Features Provided: Sensitivity Time Controls (Anti-clutter Sea),
Fast Time Constant (Anti-clutter Rain)

- (f) If receiver is tunable, describe method of adjusting frequency:
Adjustment of tuning voltage of receiver local oscillator (Automatic and manual)

1.5 Display

- (a) Type: 17 (in.) multi-color, 16-level quantization
Rasterscan, non-interlace, 1024 X 768 dots
- (b) Size of Indicator Tube: 17 in. diagonal CRT
effective dia. 225 mm
- (c) Sweep Linearity: 2 % on all ranges
- (d) Range Scales:

Range (nm)	Number of Range Rings	Range Ring Interval (nm)
0.125	5	0.025
0.25	5	0.05
0.5	5	0.1
0.75	3	0.25
1.0	5	0.2
1.5	6	0.25
2	4	0.5
3	6	0.5
4	4	1
6	6	1
8	4	2
12	6	2
16	4	4

Range (nm)	Number of Range Rings	Range Ring Interval (nm)
24	6	4
32	4	8
48	6	8
72	6	12
96	6	16
120	6	20

- (e) Range Ring Accuracy: Better than 1 % of maximum scale in use or 8 m, whichever is the greater
- (f) Overall Bearing Accuracy from Scanner to Display: Better than 1°
- (g) Target Plot Facility: Simulated afterglow in low shade
- (h) Heading Indicator: Provided, automatic alignment. Heading Line and Heading Marker
- (i) True Bearing Indicator: Provided

1.6 Antenna

- (a) Antenna Rotation ON-OFF Switch: Provided.
- (b) Reflector: Slotted waveguide array,

Radiator Type	SN4A	SN5A
Length (cm)	250	270
Length (ft)	8	8.9

- (c) Type of Beam: Vertical fan
- (d) Beam Width (between half-Radiator power points)

Radiator Type	SN4A	SN5A
Horizontal	2.60°	2.30°
Vertical	25°	25°

- (e) Polarization: Horizontal
- (f) Antenna Gain:

Radiator Type	SN4A	SN5A
(dB)	26.0	26.4

(g) Attenuation of Major Side Lobes with respect to main beam:

Radiator Type	SN4A	SN5A
Within $\pm 20^\circ$ ($\pm 10^\circ$ for (*))	-23 dB or less	-20 dB or less (*)
Outside $\pm 20^\circ$ ($\pm 10^\circ$ for (*))	-25 dB or less	-30 dB or less (*)

(h) Scanning (rotating or Rotating over 360° continuously oscillating):
clockwise

(i) Antenna Rotation Rate (rpm): 24 rpm (for RSB-0051)

(j) Number of Degrees Scanned: 360°

(k) Sector Scan: Not provided. Sector blanking available.

(l) Type of Transmission System: Contained in scanner unit

(m) Rated Loss of Transmission System per hundred feet::

None. Transmission path is only in the antenna scanner unit.

1.7 Line Power Supply Requirements

- (a) Input Voltage: 24 VDC for Display Unit
100/110/115 VAC, 50/60 Hz, 1 ϕ for Power Supply Unit
- (b) Power Drain: 135 W for Display Unit
300 VA for Power Supply Unit

1.8 Functional Controls

Range selector	Tune (manual)	EBL offset
INDEX LINE	Anti-clutter auto	Power Switch
A/C Sea control	Gain control	Panel dimmer
Heading line off	Echo stretch	MENU
Guard zone set/Audio alarm off	Range ring brilliance	Noise rejector on/off
Interference rejector	STBY/TX	Trackball (VRM,EBL,GUARD)
VRM on/off	Off-center (SHIFT)	A/C Rain control
Range set	Zoom	EBL on/off
Target trail	Brilliance (screen)	TRU/REL
Navigation on/off	Mark Brilliance	Function #1- #3
Range ring on/off	Text Brilliance	
ARPA function (option)		

1.9 Construction Features

(a) Does equipment embody replacement units with chassis type assembly:

Yes

(b) Are fuse alarms provided: Fuses are provided.

(c) State units which are weatherproof: Scanner Unit (IEC 60529 - IPX6)

(d) If all units are not housed in a single container, indicate number and give description of individual units:

1 × Display Unit Type: RDP-120

1 × Scanner Unit Type: RSB-0051 (24 V, 24 rpm)

(Transceiver Type: RTR-032 (contained in the Scanner unit))

1 × Power Supply Unit Type: PSU-002

(e) Approximate Weight of Complete Installation:

Display Unit: 36 kg

Scanner Unit: 90 kg (SN4A-RSB-0051)

92 kg (SN5A-RSB-0051)

Power Supply Unit 7 kg

(f) Approximate space required for installation excluding scanner:

Display Unit: 535 mm (W) X 822 mm (H) X 673 mm (D)

Power Supply Unit 340 mm (W) X 580 mm (H) X 140 mm (D)

1.10 Operational Features

(a) Is positive means provided to indicate whether or not the overall operation of the equipment is such that it may be relied upon to provide effective operation in accordance with its primary function:

Magnetron/Xtal checker

(b) Is the equipment for continuous operation:

Yes

(c) Is provision made for operation with shore based radar beacons (RACONS):

Yes (RACONS and SART)

2 IDENTIFICATION OF EQUIPMENT (FCC Rule § 2.925)

The following nameplates are permanently fixed on the corresponding equipment units.

FCC ID: ADB9ZWFR1760DS

Material of nameplate: Aluminum, 0.5 mm thick

MARINE RADAR	
[REDACTED]	
SCANNER UNIT	
TYPE	RSB-0051
SER. NO.	R032-
COMPASS SAFE DISTANCE	
STD [] m	STEER [] m
EQUIPMENT CLASS	<input checked="" type="checkbox"/> X
FURUNO ELECTRIC CO., LTD. 	
NISHINOMIYA CITY, MADE IN JAPAN	

Fig. 2.1
Nameplate for
Scanner Unit
(RSB-0051)

MARINE RADAR	
[REDACTED]	
POWER SUPPLY UNIT	
TYPE	PSU-002
SER. NO.	R038-
COMPASS SAFE DISTANCE	
STD [] m	STEER [] m
EQUIPMENT CLASS	<input type="checkbox"/> B
FURUNO ELECTRIC CO., LTD. 	
NISHINOMIYA CITY, MADE IN JAPAN	

Fig. 2.2
Nameplate for
Power Supply Unit
(PSU-002)

MARINE RADAR	
MODEL	FR-1760DS
DISPLAY UNIT	
TYPE	RDP-120
INPUT	24 VDC
SER. NO.	3371 -
FCC ID:	ADB9ZWFR1760DS
	FURUNO U.S.A., INC.
	MADE IN JAPAN
COMPASS SAFE DISTANCE	
STD [] m	STEER [] m
EQUIPMENT CLASS	<input type="checkbox"/> B
FURUNO ELECTRIC CO., LTD. 	
NISHINOMIYA CITY, MADE IN JAPAN	

Fig. 2.3
Nameplate for
Display Unit
(RDP-120)

3 RF POWER OUTPUT (FCC Rule § 2.985)**3.1 Microwave characteristics**

The peak voltage was determined using the divider having a ratio of 1000 to 1 and the oscilloscope. Current pulse was viewed across the wideband current transformer with output voltage per ampere 1.00.

Nominal values

Pulselength	Short	Middle 1	Middle 2	Long 1	Long 2
Range scale (nm)	0.125	3	12	48	120
Pulselength (μs)	0.08	0.20	0.60	1.20	1.20
PRR (Hz)	1900	1100	600	600	450
Duty cycle	1.52E-4	2.20E-4	3.60E-4	7.20E-4	5.40E-4
Guard band (MHz)	18.75	7.50	2.50	1.25	1.25

Measured values

Magnetron input pulse voltage was measured at its cathode using the oscilloscope and divider with ratio 1000 to 1.

Pulselength	Short	Middle 1	Middle 2	Long 1	Long 2
Directional coupler attenuation (dB)	48.50	48.50	48.50	48.50	48.50
Magnetron input voltage (kV)	10.0	10.0	10.0	10.0	10.0
Pulselength (μs) (50 % amplitude)	0.290	0.344	0.768	1.376	1.376
Rise time (μs) (10-90 % amplitude)	0.068	0.070	0.060	0.060	0.060
Decay time (μs) (90-10 % amplitude)	0.468	0.514	0.420	0.348	0.348

Magnetron input pulse current

Magnetron input pulse current was observed across the wideband current transformer with output voltage per ampere 1.00.

Pulselength	Short	Middle 1	Middle 2	Long 1	Long 2
Magnetron input current (A)	10.0	11.0	13.0	14.0	14.0

Pulselength	Short	Middle 1	Middle 2	Long 1	Long 2
Pulselength (μ s) (50 % amplitude)	0.082	0.112	0.512	1.148	1.148
Rise time (μ s) (10-90 % amplitude)	0.090	0.088	0.086	0.081	0.081
Decay time (μ s) (90-10 % amplitude)	0.112	0.150	0.204	0.348	0.348

RF envelope of the magnetron output pulse

The RF envelope of the magnetron output pulse was measured using a diode and the oscilloscope with the following results:

Pulselength	Short	Middle 1	Middle 2	Long 1	Long 2
Pulselength (μ s) (-3 dB points)	0.088	0.120	0.518	1.152	1.152
Rise time (μ s) (10-90 % amplitude)	0.018	0.020	0.022	0.033	0.033
Decay time (μ s) (90-10 % amplitude)	0.130	0.180	0.200	0.348	0.348

Estimated efficiency

The estimated efficiency of the RF generator (magnetron) was determined by the following measurements and calculation. Power output from magnetron was measured using the directional coupler, power meter and the oscilloscope.

Pulselength	Short	Middle 1	Middle 2	Long 1	Long 2
Range scale (nm)	0.125	3	12	48	120
PRR (Hz)	1813.1	1097.4	587.3	587.3	448.4
Duty cycle	1.59E-4	1.31E-4	3.04E-4	6.76E-4	5.16E-4
Magnetron input, av. (W)	15.96	14.49	39.55	94.72	72.32
Magnetron input, peak (kW)	100.00	110.00	130.00	140.00	140.00
Power meter reading (mW)	0.080	0.0758	0.191	0.452	0.340
Magnetron output, av. (W)	5.664	5.366	13.522	31.999	24.070
Spurious response limits (dB)	50.53	50.30	54.31	58.05	56.81
Magnetron Output, peak (kW):	35.50	40.75	44.45	47.30	46.60
Magnetron efficiency (%):	35.5	37.0	34.2	33.8	33.3

LABOTECH

Furuno Labotech International

Report no. : FLI 12-98-017

Peak Power Input to RF Generator : 124.0 kW

Estimated Efficiency of RF Generator : 34.8 %

4 MODULATION CHARACTERISTICS (FCC Rule §2.987)

4.1 Thyristor Trigger Pulse

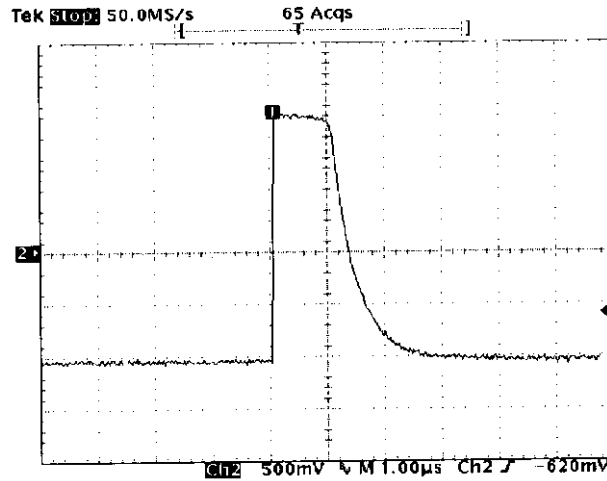

Fig. 4.1.1

Typical wave form of Trigger Pulse Scale: 5 V/div., 1 μ s/div.
(NOTE: Thyristor trigger pulse is common to all ranges)

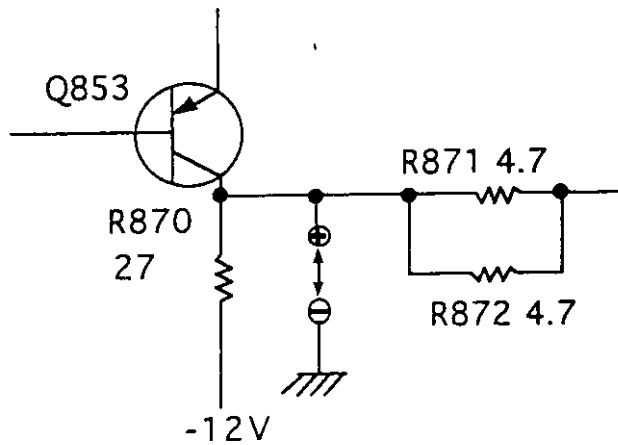

Fig. 4.1.2 Test Point for Trigger Pulse
(in RTB board (03P6666) of Scanner Unit (RSB-0051))

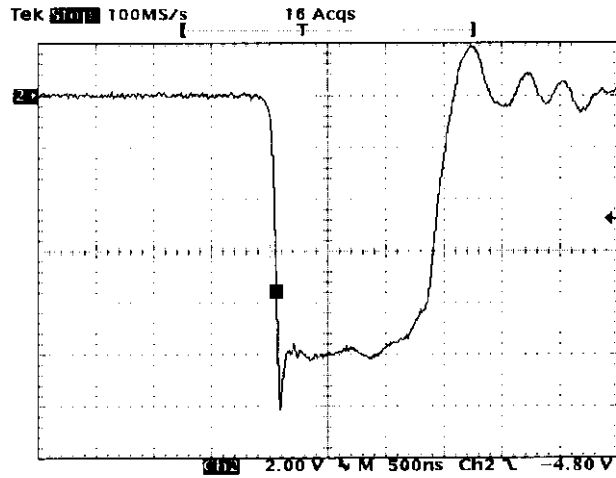

Fig. 4.2.4

Long 1 Pulse (48 nm Range)

Scale: 2 kV/div. 500 ns/div.

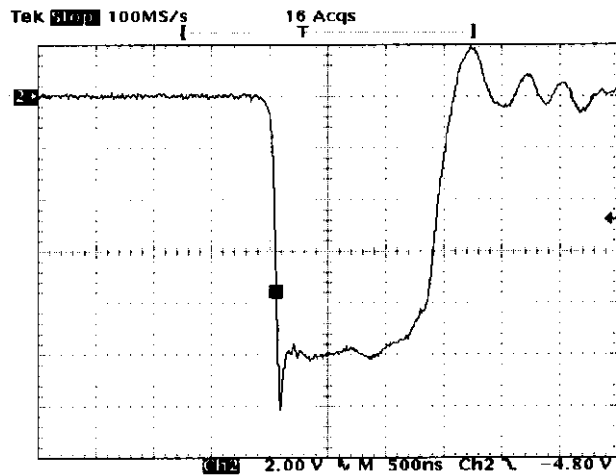

Fig. 4.2.5

Long 2 Pulse (120 nm Range)

Scale: 2 kV/div. 500 ns/div.

4.2 Trigger Pulse at Magnetron Cathode

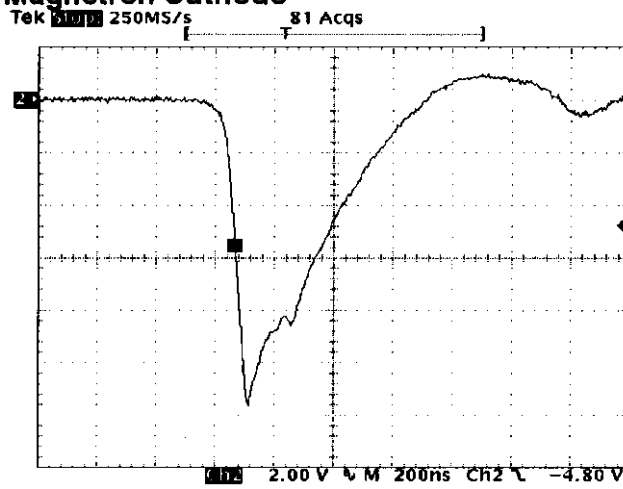

Fig. 4.2.1

Short Pulse (0.125 nm Range)

Scale: 2 kV/div. 200 ns/div.

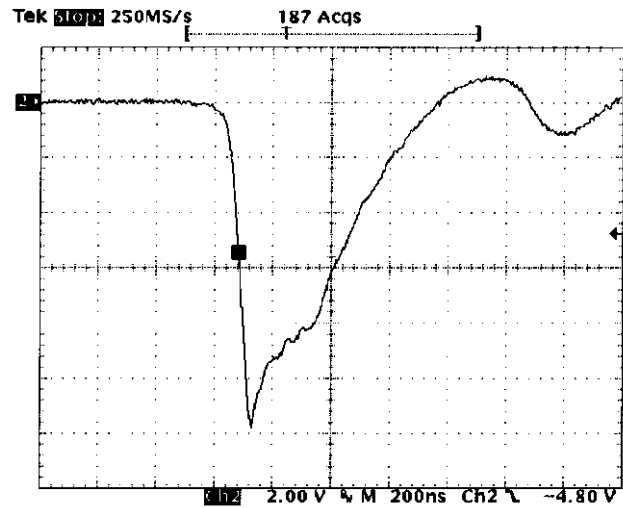

Fig. 4.2.2

Middle 1 Pulse (3 nm Range)

Scale: 2 kV/div. 200 ns/div.

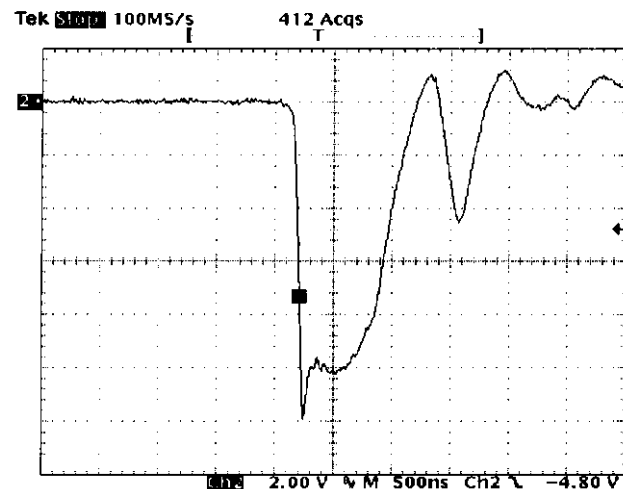

Fig. 4.2.3

Middle 2 Pulse (12 nm Range)

Scale: 2 kV/div. 500 ns/div.

4.3 Magnetron Output (detected):

4.3.1 Setup for Measurement:

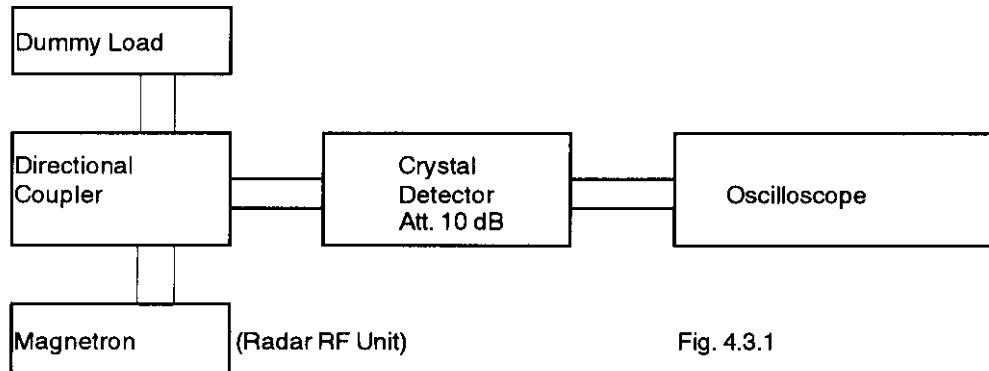

Fig. 4.3.1

4.3.2 Measuring Equipment List:

See ATTACHMENT 4 [LIST OF TEST/MEASURING EQUIPMENT].

4.3.3 Measured Data:

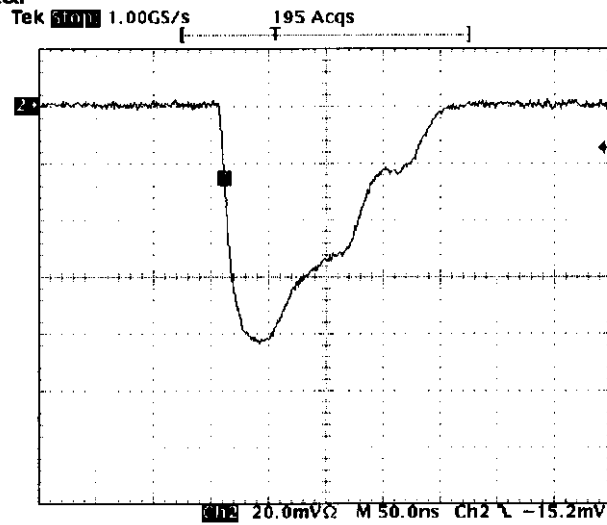

Fig. 4.3.2 Short Pulse (0.125 nm Range) Scale: 20 mV/div. 50 ns/div.

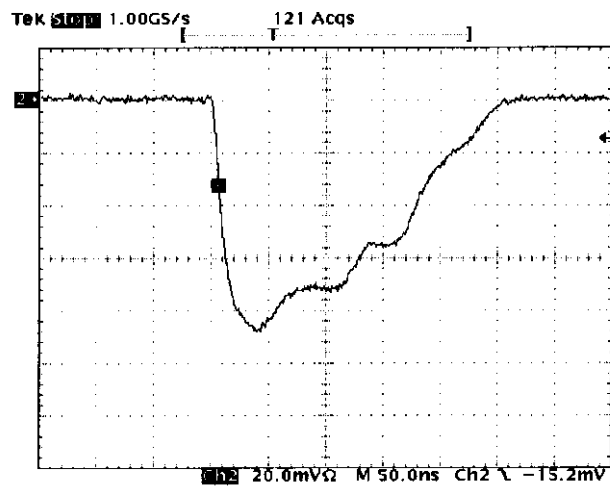

Fig. 4.3.3 Middle 1 Pulse (3 nm Range) Scale: 20 mV/div. 50 ns/div.

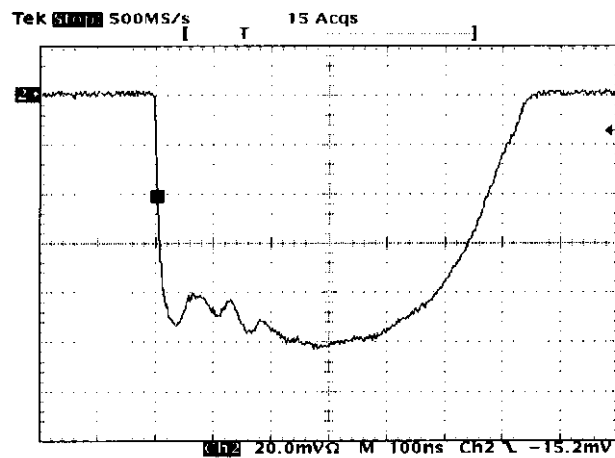

Fig. 4.3.4 Middle 2 Pulse (12 nm Range) Scale: 20 mV/div. 100 ns/div.

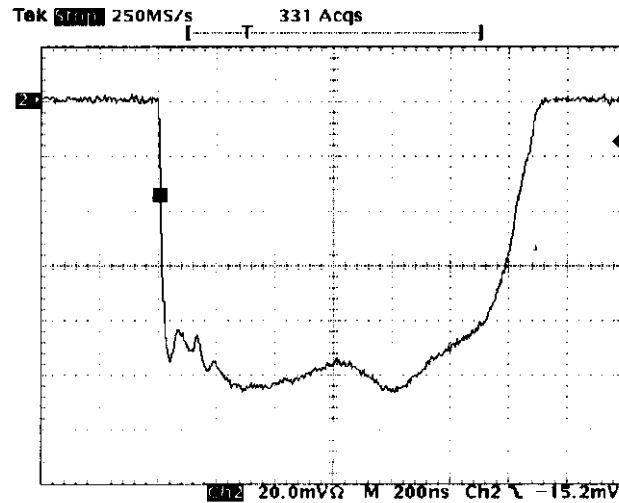

Fig. 4.3.5

Long 1 Pulse (48 nm Range)

Scale: 20 mV/div. 200 ns/div.

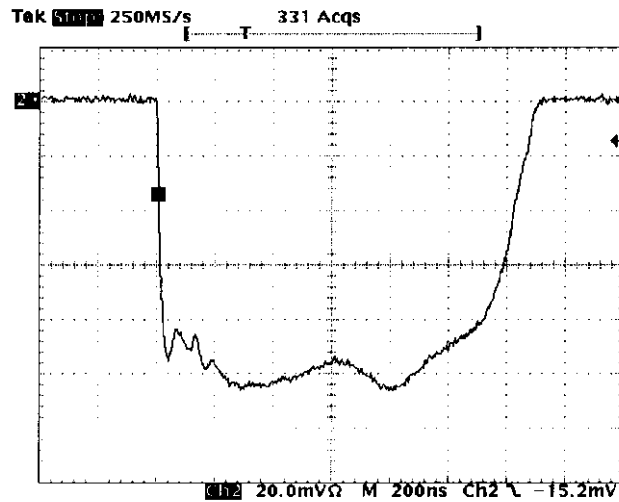

Fig. 4.3.6

Long 2 Pulse (120 nm Range)

Scale: 20 mV/div. 200 ns/div.

4.4 Radar Pulse Spectrum:

Measured by the spectrum analyzer.

(Test Equipment Setup and Measuring Equipment List are same as Clause 6.1 and 6.2.)

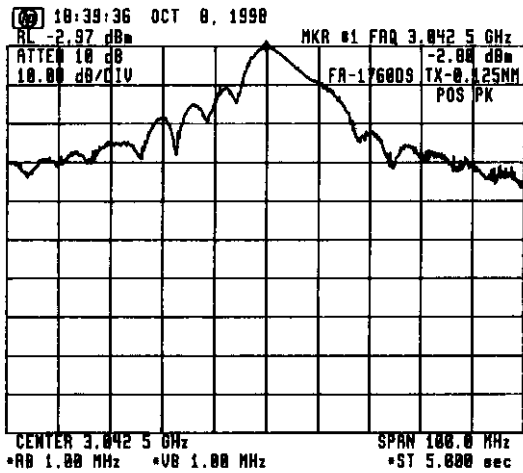

Fig. 4.4.1 For Short Pulse (0.125 nm Range)

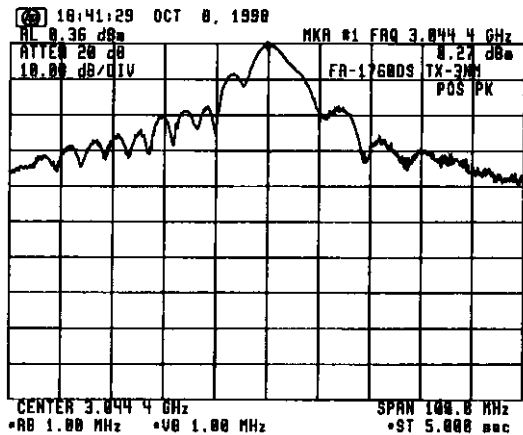

Fig. 4.4.2 For Middle 1 Pulse (3 nm Range)

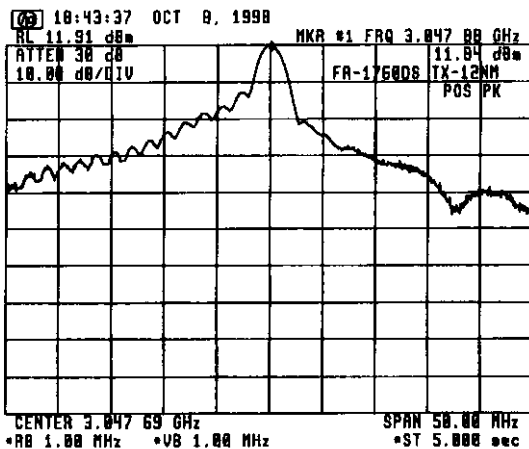

Fig. 4.4.3 For Middle 2 Pulse (12 nm Range)

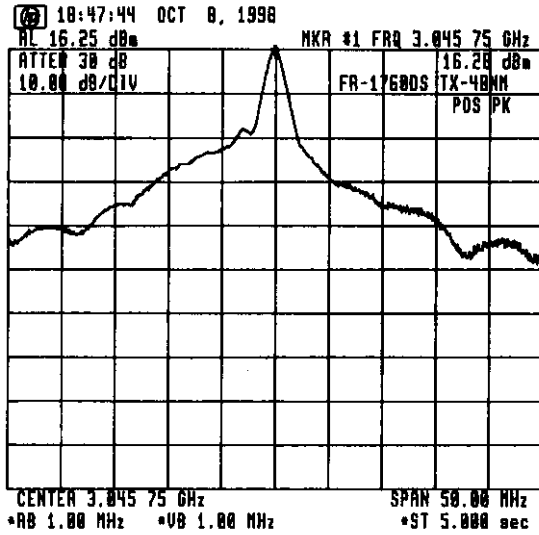

Fig. 4.4.4 For Long 1 Pulse (48 nm Range)

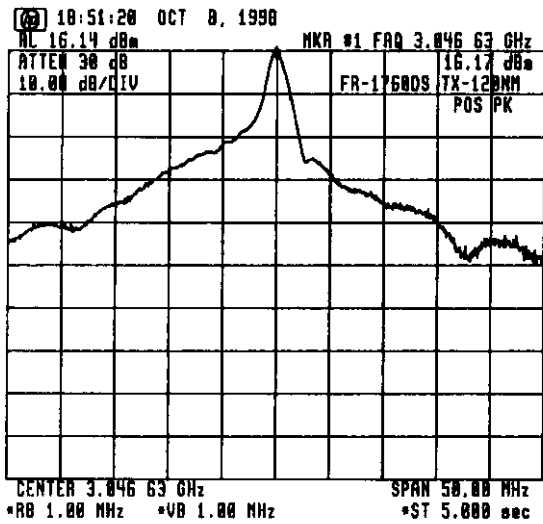

Fig. 4.4.5 For Long 2 Pulse (120 nm Range)

5 OCCUPIED BANDWIDTH (FCC Rule § 2.989)

5.1 Measuring Method

FCC rule 47 CFR 2.989 requires measurements of the occupied bandwidth which is defined in the same section as "the frequency bandwidth such that, below its lower and above its upper frequency limits, the mean powers radiated are each equal to 0.5 percent of the total mean power radiated by a given emission."

To obtain the occupied bandwidth of the radar transmitter, a special program (program list shown below) was loaded to the Hewlett-Packard spectrum analyzer and run by entering the HP-provided POWER BANDWIDTH calculation command [PWRBW].

The result was automatically displayed on the screen on the spectrum analyzer as:

POWER_BW=----- MHz

```
10 ! HP_71000 DOWNLOAD PROGRAM
20 ASSIGN @Sa TO 718
30 CLEAR @Sa
40 CALL M_ain(@Sa)
50 LOCAL @Sa
60 END
70 !
80 SUB M_ain(@Sa)
90 M_ain: !
100 CALL Pwr_bw(@Sa)
110 CALL Limit_line(@Sa)
120 !
130 OUTPUT @Sa;"VARDEF K_ey,0;";
140 !
150 OUTPUT @Sa;"FUNCDEF D_LP,^";
160 OUTPUT @Sa;"MOV K_ey,0;";
170 !
180 Main menu: !
190 OUTPUT @Sa;"REPEAT;";
200 OUTPUT @Sa;"READMENU K_ey;";
210 ! location: %Top----Bottom-%
220 OUTPUT @Sa;"1,%Limit line %;";
230 OUTPUT @Sa;"2,%Power bw %;";
240 OUTPUT @Sa;"14,% Exit%;";
250 !
260 OUTPUT @Sa;"IF K_ey,EQ,1;THEN;LIMIT_LINE;";
270 OUTPUT @Sa;"ELSIF K_ey,EQ,2;THEN;PWR_BW;";
280 OUTPUT @Sa;"ELSIF K_ey,EQ,14;THEN;ABORT;";
290 OUTPUT @Sa;"ENDIF;";
300 OUTPUT @Sa;"UNTIL K_ey,EQ,14;";
310 OUTPUT @Sa;"IP;TS;";
320 OUTPUT @Sa;"ADORT;";
330 OUTPUT @Sa;"^"
340 !
350 Define_keydef: !
360 OUTPUT @Sa;"KEYDEF 7,D_LP, %DLP TEST%;";
370 !
380 OUTPUT @Sa;"FUNCDEF D,^";
390 OUTPUT @Sa;"KEYPST;";
400 OUTPUT @Sa;"^"
410 !
420 SUBEND
430 !
440 SUB Limit_line(@Sa)
450 Limit_line: !
460 OUTPUT @Sa;"CLRDSP;";
470 OUTPUT @Sa;"FUNCDEF LIMIT_LINE,^";
480 OUTPUT @Sa;"PU;PA 0,654;";
490 OUTPUT @Sa;"LINET 1;";
500 OUTPUT @Sa;"PD;PA 100,654;";
510 OUTPUT @Sa;"PU;PA 201,654;";
520 OUTPUT @Sa;"PD;PA 300,654;";
530 OUTPUT @Sa;"PU;PA 105,630;";
540 OUTPUT @Sa;"TEXT @-35dB@;";
550 OUTPUT @Sa;"PU;PA 205,720;";
560 OUTPUT @Sa;"TEXT @-25dB@;";
570 OUTPUT @Sa;"PU;PA 301,743;";
580 OUTPUT @Sa;"LINET 1;";
590 OUTPUT @Sa;"PD;PA 400,743;";
600 OUTPUT @Sa;"PU;PA 601,743;";
610 OUTPUT @Sa;"LINET 1;";
620 OUTPUT @Sa;"PD;PA 700,743;";
630 OUTPUT @Sa;"PU;PA 701,654;";
640 OUTPUT @Sa;"LINET 1;";
650 OUTPUT @Sa;"PD;PA 1000,654;HD;";
660 OUTPUT @Sa;"^"
670 SUBEND
680 SUB Pwr_bw(@Sa)
690 Pwr_bw: !
700 ! Calculating Power band width
710 OUTPUT @Sa;"VARDEF P_bw,0;";
720 OUTPUT @Sa;"FUNCDEF PWR_BW,^";
730 OUTPUT @Sa;"CLRW TRA;";
740 OUTPUT @Sa;"CLRDSP;";
750 OUTPUT @Sa;"SNGLS;";
760 OUTPUT @Sa;"MXMH TRA;TS;TS;";
770 OUTPUT @Sa;"MOV P_bw,PWRBW TRA,99.0;";
780 OUTPUT @Sa;"DIV P_bw,P_bw,1000000;";
790 OUTPUT @Sa;"PU;PA 10,800;HD;";
800 OUTPUT @Sa;"TEXT @POWER_BW = @;";
810 OUTPUT @Sa;"DSPLY P_bw,8,3;";
820 OUTPUT @Sa;"TEXT @ MHz @;";
830 OUTPUT @Sa;"^"
840 SUBEND
```

Fig. 5.1

Program for Calculation of Occupied Bandwidth

6 SPURIOUS EMISSIONS AT ANTENNA TERMINAL (FCC Rule §2.991)

6.1 Test Equipment Setup:

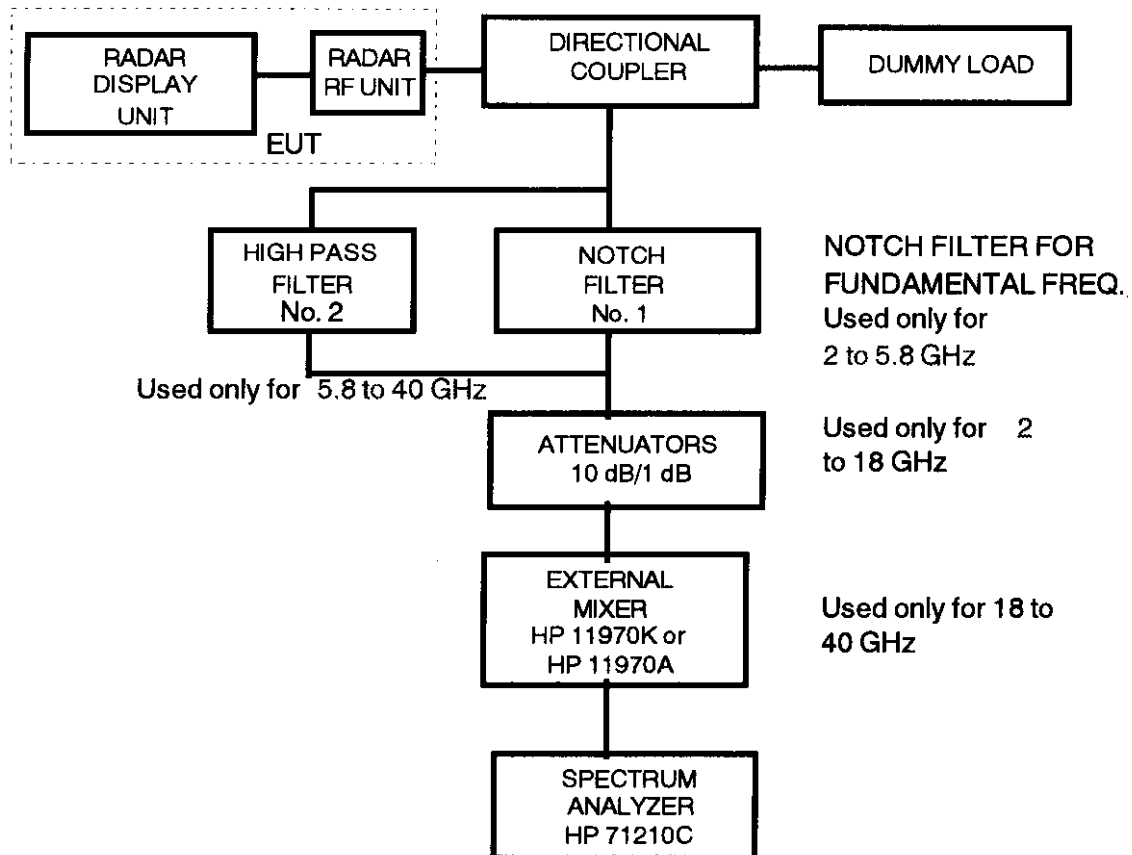

Fig. 6.1

6.2 Measuring Equipment List:

See ATTACHMENT 4 [LIST OF TEST/MEASURING EQUIPMENT].

- Note : (1) The characteristics of Notch Filter (No. 1) are described in Fig. 6.2 to Fig. 6.5.
(2) The characteristic of High Pass Filter (No. 2) is described in Fig. 6.6.

6.3 Test Conditions:

Radar Range Settings: 0.125 nm (Short)/ 3 nm (Middle 1)/ 12 nm (Middle 2)
48 nm (Long 1)/ 120 nm (Long 2)

6.4 Emission Limits:

- (a) Frequency Range (FCC Rule § 2.997) : 10 kHz - 40 GHz
- (b) Emission Limits (FCC Rule § 80.211) :

Frequency removed from the assigned frequency	Frequency (Hz)	Emission attenuation (mean power ,dB)
50 - 100 % (of the authorized bandwidth)	2950 - 3000 M	At least 25
	3100 - 3150 M	
100 - 250 %	2800 - 2950 M	At least 35
	3150 - 3300 M	
more than 250 %	10 k - 2800 M	At least $43 + 10 \log_{10}$ (mean power in watts)
	3300 - 40,000 M	

Note : (1) Assigned frequency (center frequency) = 3050 MHz

(2) Authorized bandwidth = 100 MHz

6.5 Test Results:

As shown in ATTACHMENT 1 , the spurious emissions at antenna terminal of EUT are found lower than the specified limits.

(Note: Spurious emissions for 10 kHz to 2 GHz are not found due to the antenna terminal structure. (wave guide tube)).

Characteristic of Filter No.1 (for S-band)

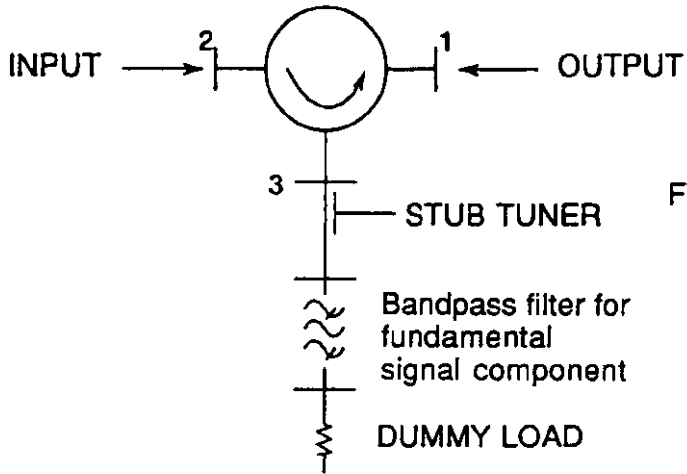

Fig. 6.2 Setup of Notch Filter No.1

This notch filter is used to increase the dynamic range of the spectrum analyzer.

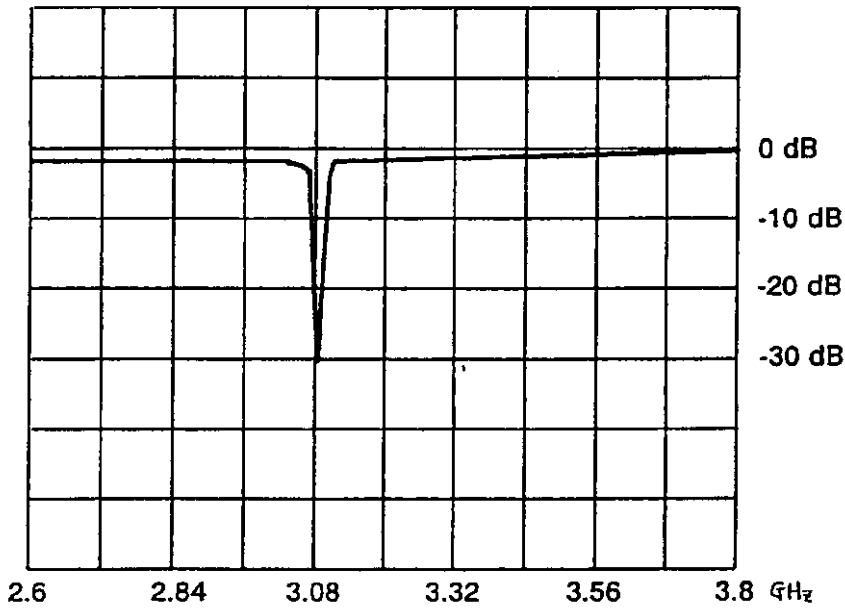

Fig. 6.3

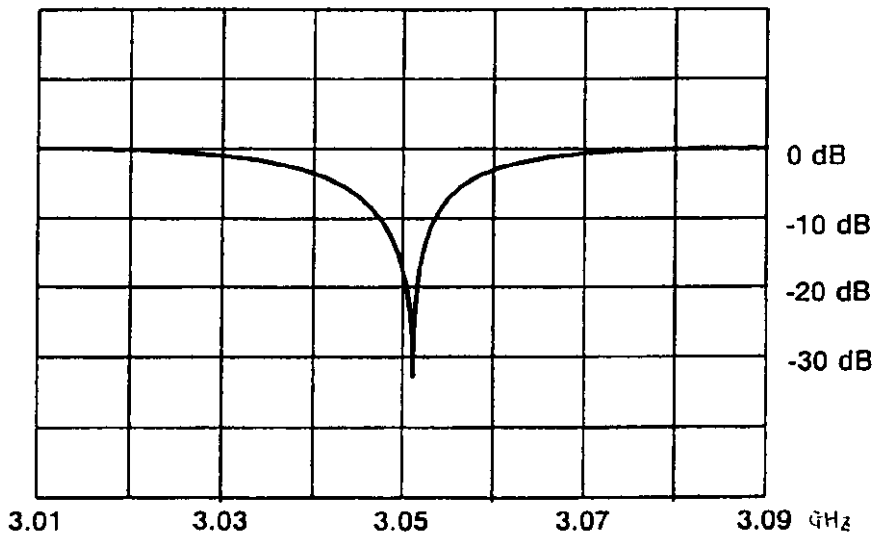
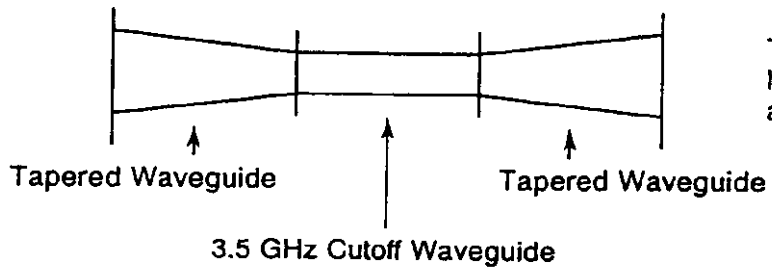

Fig. 6.4

Characteristic of Filter No. 2 (for S-band)



This filter is used to filter out the high level fundamental signal to avoid damage to the analyzer.

Fig. 6.5

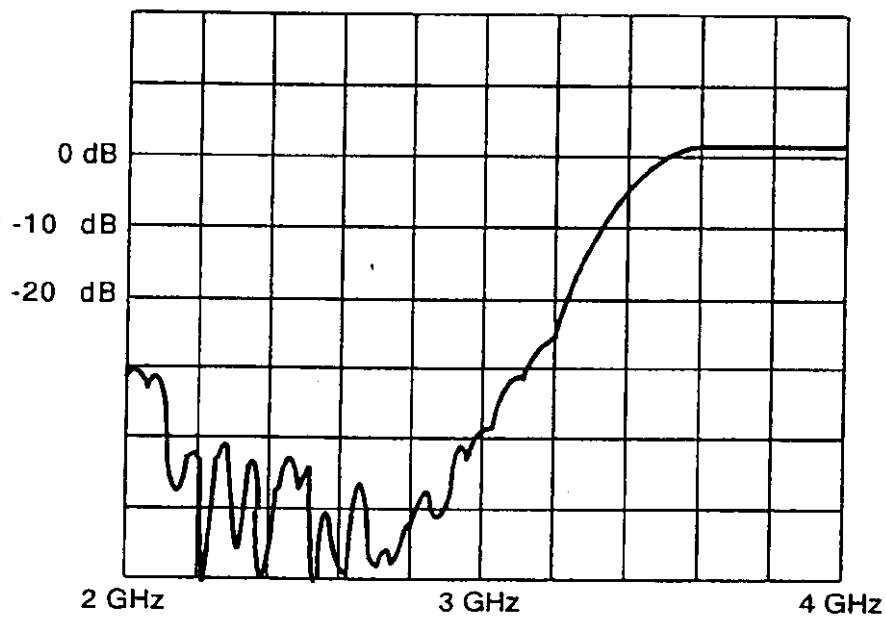

Fig. 6.6

7 FIELD STRENGTH OF SPURIOUS RADIATION (FCC Rule § 2.993)

7.1 Test Site: Rooftop of 6-story building,
FURUNO ELECTRIC CO., LTD.
Ashihara- cho 9-52, Nishinomiya-city, 662-8580 Japan

7.2 Date: Dec., 1998

7.3 Distance between the radar set and measuring antenna: 10 m

7.4 Radar Range settings: 0.125 nm (Short)/3 nm (Middle 1)/ 12 nm (Middle 2)
48 nm (Long 1)/ 120 nm (Long 2)

7.5 Measuring Equipment List:

See ATTACHMENT 4 [LIST OF TEST/MEASURING EQUIPMENT].

7.6 Test settings:

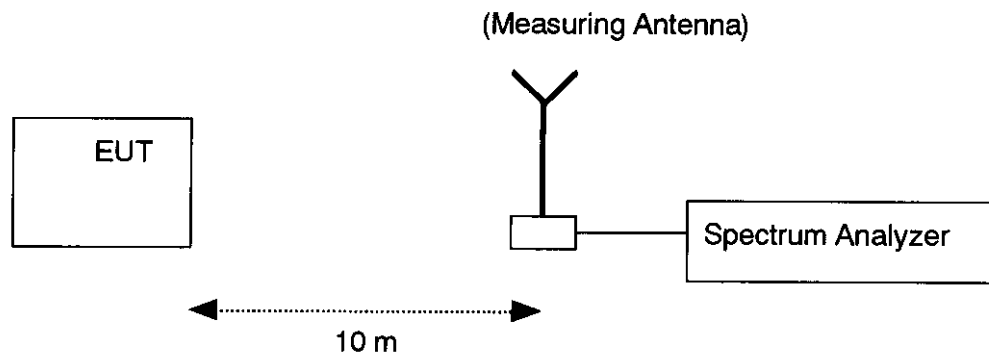

7.7 Field Strength Limits:

(a) Frequency Range (FCC Rule § 2.997) : 10 kHz - 40 GHz

(b) Emission Limits (FCC Rule § 80.211) :

Frequency removed from the assigned frequency	Frequency (Hz)	Emission attenuation (mean power ,dB)
50 - 100 % (of the authorized bandwidth)	2950 - 3000 M	At least 25
	3100 - 3150 M	
100 - 250 %	2800 - 2950 M	At least 35
	3150 - 3300 M	

Frequency removed from the assigned frequency	Frequency (Hz)	Emission attenuation (mean power ,dB)
more than 250 %	10 k - 2800 M 3300 - 40,000 M	At least $43 + 10 \log_{10}$ (mean power in watts)

Note : (1) Assigned frequency (center frequency) = 3050 MHz

(2) Authorized bandwidth = 100 MHz

7.8 Test Results:

As shown in ATTACHMENT 2 , the field strengths of spurious radiation generated by EUT are found lower than the specified limits.

8 FREQUENCY STABILITY (FCC Rule § 2.995)

8.1 Setup for Measurement

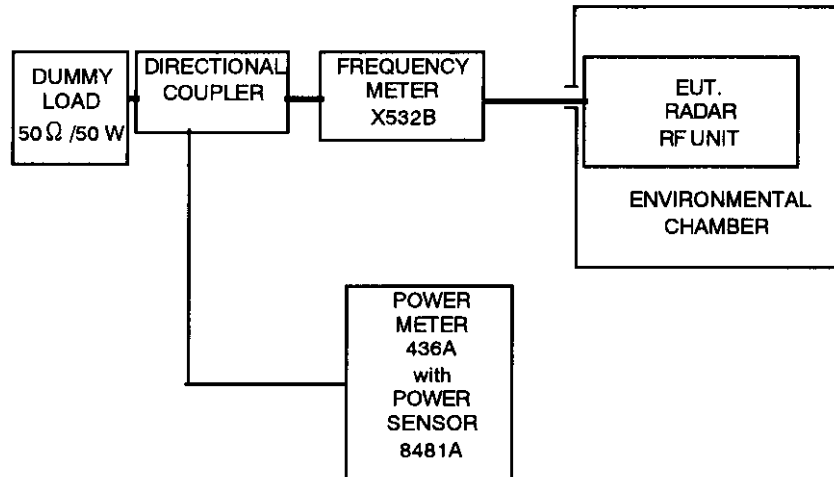

Fig. 8.1

8.2 Test Conditions:

- 1) Radar Range settings : 0.125 nm (Short)/3 nm (Middle 1)/ 12 nm (Middle 2)
48 nm (Long 1)/ 120 nm (Long 2)
- 2) Ambient Temperature settings: - 20 to + 50 °C (10 °C step)
- 3) Power Supply Voltage settings: 85 /115 % of nominal voltage (85 to 115 VAC)

8.3 Measuring Equipment List:

See ATTACHMENT 4 [LIST OF TEST/MEASURING EQUIPMENT].

8.4 Frequency Tolerance Limits:

"The frequency at which maximum emission occurs must be within the authorized bandwidth and must not be closer than $1.5/T$ MHz to the upper and lower limits of the authorized band width, where "T" is the pulse duration in microseconds. "

(FCC Rule § 80.209)

1) Center frequency (f_0): 3050 MHz

2) Authorized bandwidth ($f(AUBW)$): 100 MHz

"Upper limit frequency of the authorized band", $f(UAUBW) = f_0 + f(AUBW)/2 = 3100$ MHz

"Lower limit frequency of the authorized band", $f(LAUBW) = f_0 - f(AUBW)/2 = 3000$ MHz

3) Assignable frequency bandwidth : 200 MHz (between 2900 MHz and 3100 MHz)

(FCC Rule § 80.375 (d)-(1))

"Upper limit frequency of the assignable band", $f(UASB) = 3100$ MHz

"Lower limit frequency of the assignable band", $f(LASB) = 2900$ MHz

4) Guard Band ($f(1.5/T)$) :

Pulselength	Short	Middle 1	Middle 2	Long 1	Long 2
Range Scale (nm)	0.125	3	12	48	120
Pulselength (μ sec)	0.08	0.20	0.60	1.20	1.20
Guard Band $f(1.5/T)$ (MHz)	18.75	7.50	2.50	1.25	1.25

8.5 Test Results:

Shown on Fig. 8.2.

(1) "Upper Tolerance Frequency measured (at -20 °C)", $f(U) = 3050.0$ MHz

(2) "Lower Tolerance Frequency measured (at $+50$ °C)", $f(L) = 3040.4$ MHz

(3)-(a)

$f(U) + \max. f(1.5/T) = 3068.8$ MHz $< f(UAUBW) = 3100$ MHz $\leq f(UASB) = 3100$ MHz

(3) - (b)

$f(L) - \max. f(1.5/T) = 3021.6$ MHz $> f(LAUBW) = 3000$ MHz $\geq f(LASB) = 2900$ MHz

So, both are found within the specified limits.

FREQUENCY STABILITY WITH VARIATION OF PRIMARY SUPPLY VOLTAGE:

The built-in voltage regulator allows no frequency variation against variations of

$\pm 15\%$ of nominal power supply voltage (85 to 115 VAC for nominal 100 VAC).

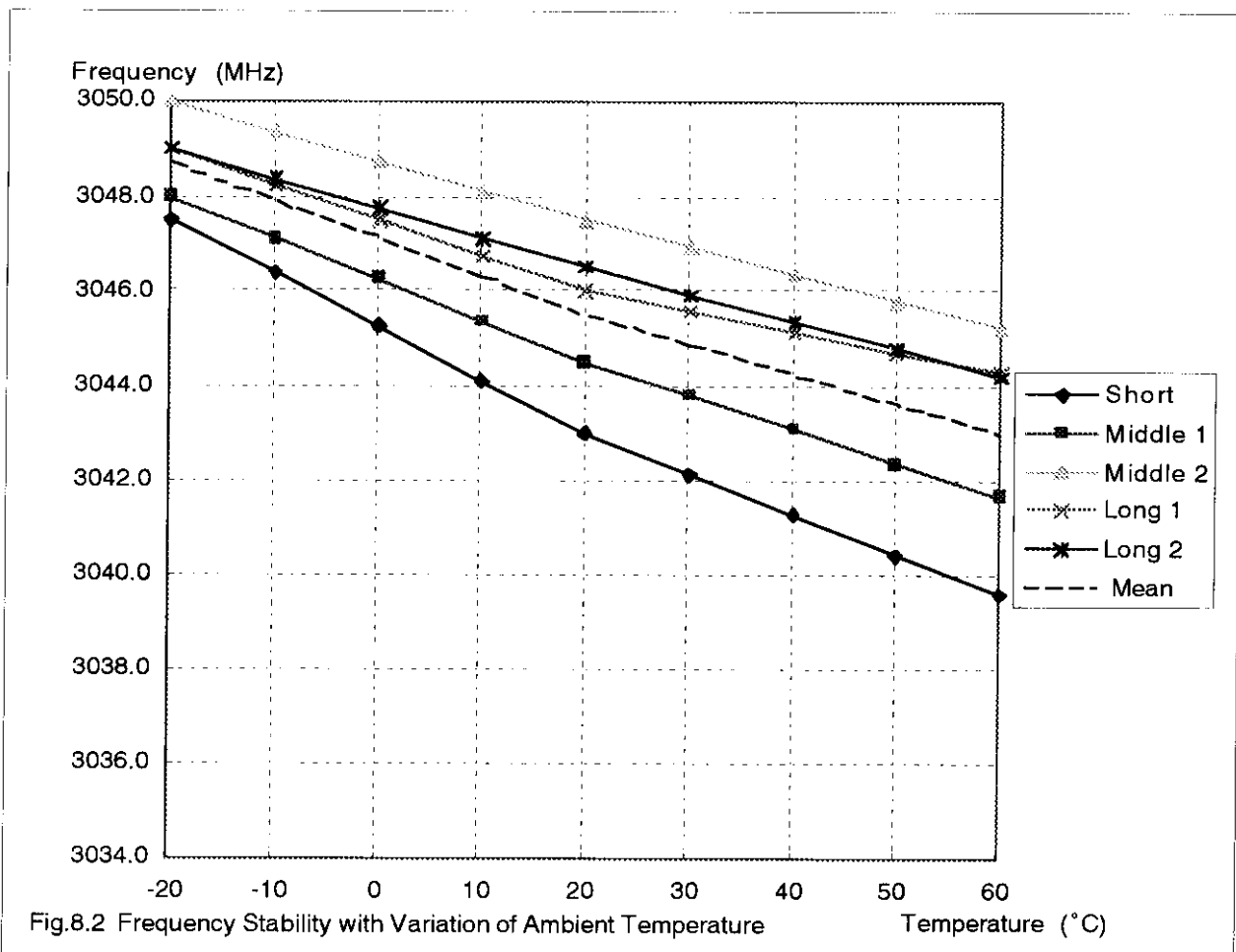

9 SUPPRESSION OF INTERFERENCE ABOARD SHIPS

(FCC Rule § 80.217)

9.1 Measuring Antenna Characteristics at Representative Frequencies:

Whip antennas are used to determine the level of interference caused by the radar to shipboard receivers. These antennas have the following characteristics (refer to impedance charts attached):

Length	Test Frequency (Hz)	Impedance (Ω)	θ	R (Ω)	C or L
6 m	500.5 k	1 k	-90 °	0	80 pF
6 m	1.992 M	1.25 k	-86 °	87.2	64 pF
6 m	10.00204 M	158		109	140 pF
4 m	27.5 M	95		83.5	128 pF
5/8 λ	150 M	116.5		105.5	52.5 nH
1/4 λ	450 M	70.5		34.5	5.68 pF

9.2 Test Site: Rooftop of 6-story building,
Furuno Electric Company, Ltd.
Ashihara-cho 9-52, Nishinomiya-city, 662-8580 JAPAN

9.3 Measuring Instruments:

- (1) RF Vector Impedance Meter, HP 4815A
- (2) Spectrum Analyzer, ADVANTEST TR4172
- (3) Spectrum Analyzer, HP 8566B
- (4) Antennas,
for 14 k - 10 MHz, 6 m whip
for 10 - 30 MHz, 4 m whip
for 30 - 300 MHz, VHF whip
for 300 - 1000 MHz, UHF whip

9.4 Test Results:

Interference levels to the respective antenna were measured at 2 m from the radar which was put in OFF and TRANSMIT conditions, and found within the specified limits.

9.4.1 Harmful Interference to Receiver (FCC Rule § 80.217 (a))

Limits: for 14 - 490 kHz, 5 $\mu\text{V}/\text{m}$
for 490 kHz - 1 GHz, 1 $\mu\text{V}/\text{m}$

Results: There is no spurious component which is deemed harmful interference. (Test data are shown in ATTACHMENT 3)

9.4.2 Electromagnetic Field (FCC Rule § 80.217 (b) - 1)

Limits: for below 30 MHz, 0.1 $\mu\text{V}/\text{m}$ at 1 nm (-20 dB $\mu\text{V}/\text{m}$)
for 30 to 100 MHz, 0.3 $\mu\text{V}/\text{m}$ at 1 nm (-10.5 dB $\mu\text{V}/\text{m}$)
for 100 to 300 MHz, 1.0 $\mu\text{V}/\text{m}$ at 1 nm (0 dB $\mu\text{V}/\text{m}$)
for over 300 MHz, 3.0 $\mu\text{V}/\text{m}$ at 1 nm (9.5 dB $\mu\text{V}/\text{m}$)

Results: Interference was measured with the antenna located 2 m from the radar and converted to levels at 1 nm. There is no spurious component exceeding the limits.
(Test data are shown in ATTACHMENT 3)

9.4.3 Power Input to an Artificial Antenna (FCC Rule § 80.217 (b) - 2)

Limits: for below 30 MHz, 400 μW
for 30 to 100 MHz, 4,000 μW
for 100 to 300 MHz, 40,000 μW
for over 300 MHz, 400,000 μW

Results: There is no spurious component exceeding the limits.
(Test data are shown in ATTACHMENT 3)

MEASUREMENT OF IMPEDANCE OF TEST ANTENNAS

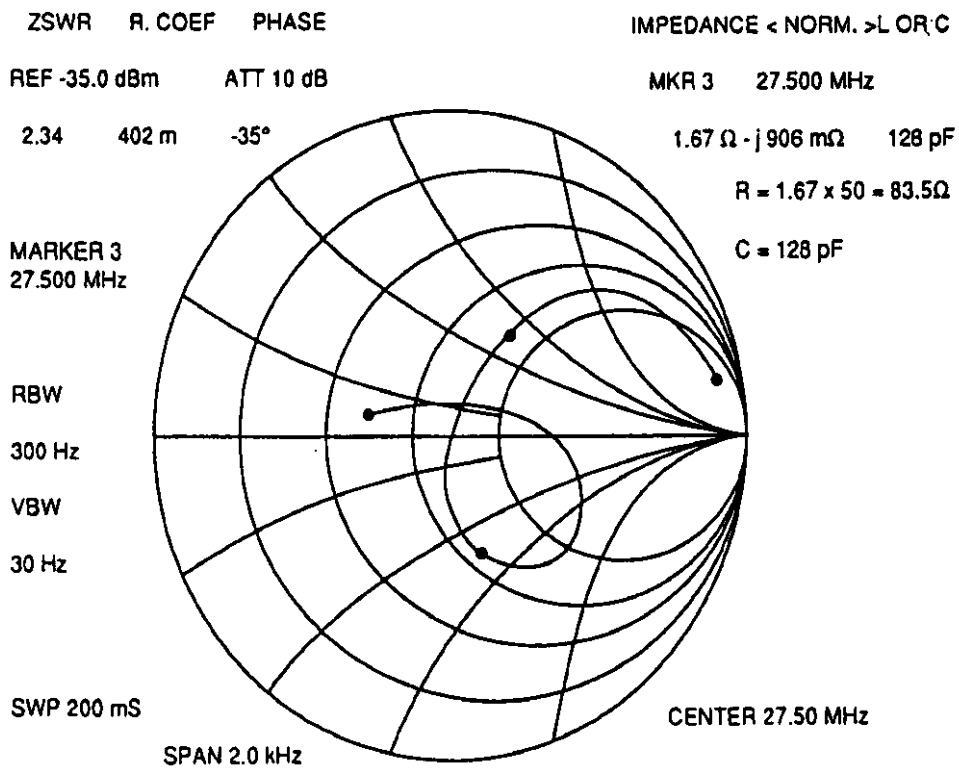
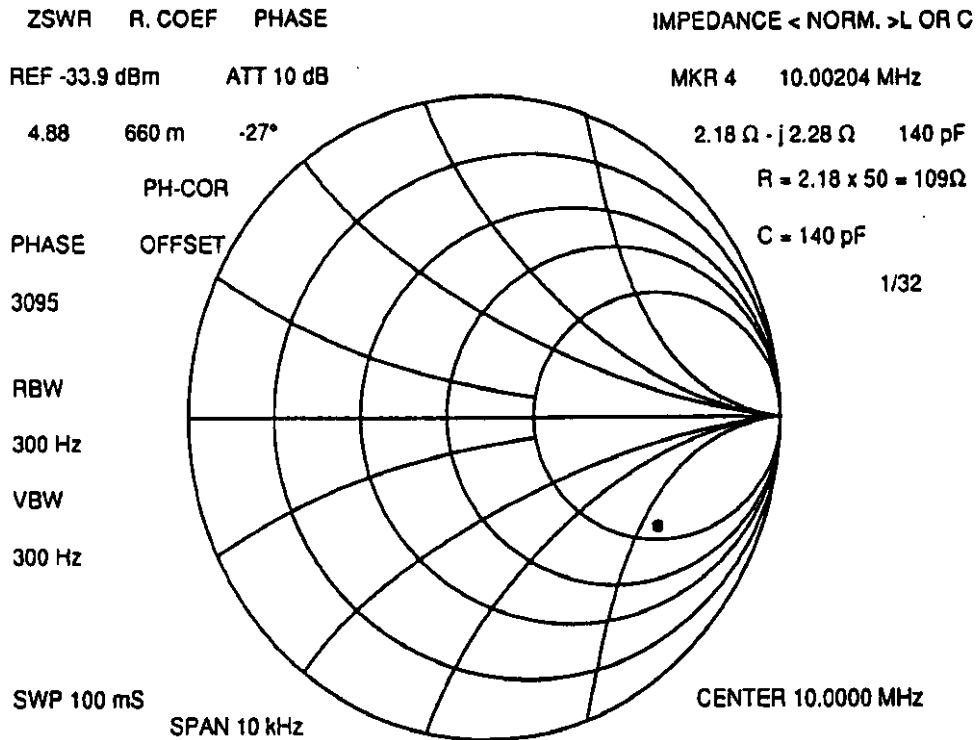

MEASUREMENT OF IMPEDANCE OF TEST ANTENNAS

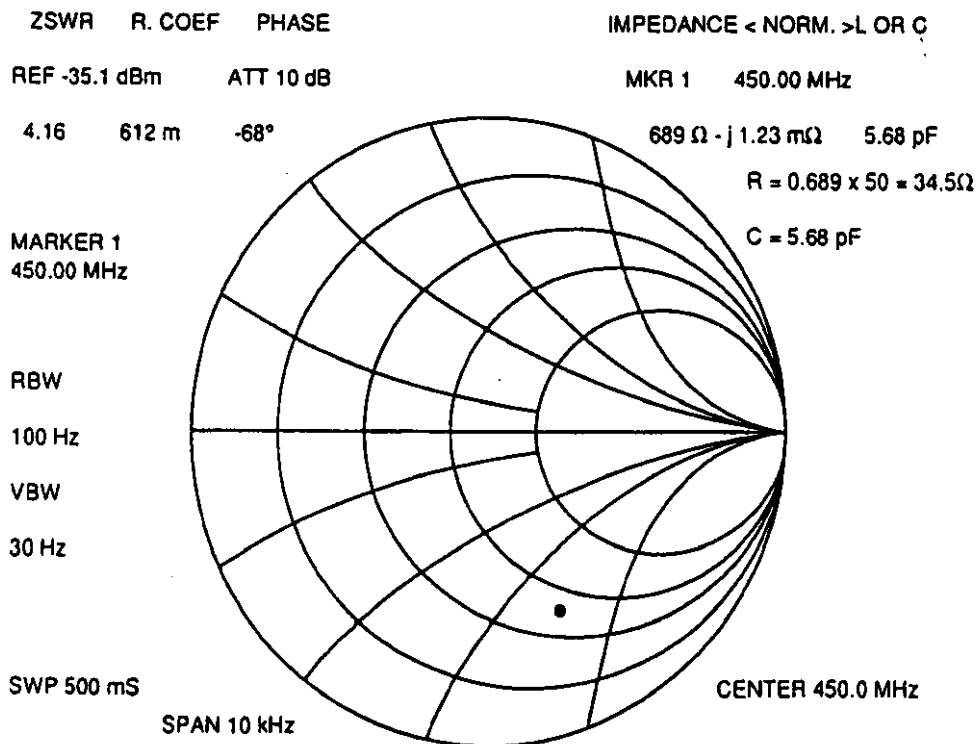
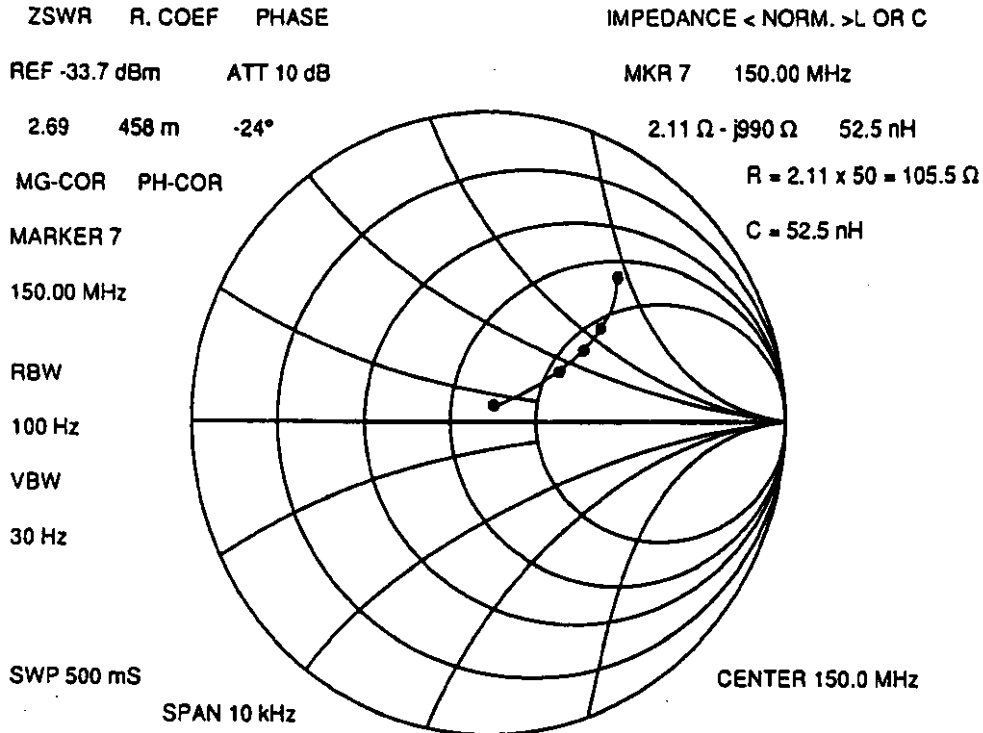

11 TECHNICAL DESCRIPTION OF EQUIPMENT (FCC Rules § 2.983)

11.1 Function of Each Semiconductor or Active Device (FCC Rule § 2.983 (d)(6))

ANTENNA UNIT

TRANSCEIVER MODULE (RTR-032)

Modulator Trigger PCB 03P6666

CR850:	Switching
CR851:	Switching
CR853:	Reverse Voltage Protection
CR854:	Switching
CR855:	Reverse Voltage Protection
CR856:	Reverse Voltage Protection
CR857:	Reverse Voltage Protection
CR858:	Reverse Voltage Protection
Q850:	Switching
Q853:	SCR Driver
Q854:	Switching
Q884:	Current Amplifier
U850:	Monostable Multivibrator
U851:	AND Gate
U852:	Inverter
U853 :	Inverter

Modulator PCBs 03P6668/03P6827/03P6669

CR801:	Charging
CR802:	Charging
CR807:	Switching
CR816:	SCR Protection
CR817:	SCR Protection
CR818:	SCR Protection
CR819..	SCR Protection
CR820:	SCR Protection
CR821:	SCR Protection
CR822:	SCR Protection

LABOTECH

Furuno Labotech International

Report no. : FLI 12-98-017

CR823:	SCR Protection
CR824:	SCR Protection
CR825:	Reverse Voltage Protection
CR840:	Switching
CR842:	Switching

Chassis Mounted Parts

B13:	Diode Limiter
B14:	Diode Limiter
CR803:	Relay Driver Protection
CR804:	Relay Driver Protection
CR805:	Relay Driver Protection
CR808:	Reverse Voltage Protection
CR809:	Reverse Voltage Protection
CR813:	SCR Switching
CR814:	SCR Switching
CR815:	SCR Switching
V801 :	Magnetron. microwave oscillator
HY801:	Circulator
U801:	MIC, frequency converter
L801:	Charging choke
T801:	Pulse transformer

IF Amplifier PCB 03P6570

CR601:	Switching
CR602:	Switching
CR603:	Switching
CR604:	Switching
CR605:	Switching
CR606:	Switching
CR608:	Thermal Sensor
CR609:	Level Shift
CR610:	Limiter
CR611:	Switching
CR612:	Switching
CR613:	Switching

CR614:	Frequency Adjuster
CR615:	LED
CR616:	Temperature Compensation
CR617:	Tuning Voltage Limiter
CR618:	Zener Diode
CR621:	Limiter
CR623:	Tuning Detector
CR624:	Attenuators
CR625:	Limiter
CR626:	Reverse Voltage Protection
CR627:	Reverse Voltage Protection
Q601:	IF Amplifier
Q602:	Switching
Q603:	Buffer Amplifier
Q604:	Buffer Amplifier
Q605:	Buffer Amplifier
Q606:	Buffer Amplifier
Q607:	Buffer Amplifier
Q608:	IF Switching
Q609:	IF Amplifier
Q610:	DC Amplifier
Q611:	Cascade Amplifier
Q601 to U610:	IF Amplifier
U611:	Voltage Regulator
U612:	Voltage Regulator
U613:	Voltage Regulator
U614:	Voltage Regulator
U615:	MBS Pulse forming Network and Bandwidth Selector
U616:	Tuning Amplifier

STC PCB ATT-7362

CR1:	Overvoltage Protection
CR2:	Overvoltage Protection
CR3:	Switching
CR4:	Level Shift
CR5:	Overvoltage Protection
CR6:	Overvoltage Protection
CR7:	Overvoltage Protection

CR8:	Thermal Compensation
CR9:	Thermal Compensation
CR10:	Thermal Compensation
CR11:	Thermal Compensation
Q1:	Buffer
Q2:	Emitter Follower
Q3:	Emitter Follower
Q4:	Current Mirror Circuit
Q5:	Current Mirror Circuit
Q6:	Switching
Q7:	Switching
U1:	DC Amplifier
U2:	Monostable Multivibrator

MBS PCB 03P6569

CR501 :	Overvoltage protection
CR503:	Overvoltage protection
CR504:	Overvoltage protection
CR505:	Overvoltage protection
CR506:	Overvoltage protection
CR507:	Overvoltage protection
CR508:	Switching
CR509:	Switching
CR510:	Switching
CR511:	Overvoltage protection
CR512:	Switching
CR513:	Switching
CR514:	Switching
CR515:	Switching
CR517:	Reverse voltage protection
Q501:	Emitter-followed amplifier
U501:	DC amplifier
U512:	DC regulator
U503:	Monostable multivibrator

Bearing Signal Generator PCB MP-3795/03P6609

Q901: Pulse Amplifier
Q902: Pulse Amplifier
U901: Photo Interrupter
U902: Comparator

Interface Board 03P9004

CR1: Switching
CR2: Switching
CR3: Switching
U1: Comparator

Motor Control PCB MSS-7737

CR1: Switching
CR2: Switching
CR3 : Switching
CR4: Switching
Q 1: Switching

11.2 Description of the circuits employed for suppression of spurious radiation, for limiting or shaping the control pulse, and for limiting or controlling power

(FCC Rule § 2.983 (d) (11))

ANTENNA UNIT

TRANSCEIVER MODULE (RTR-032)

Modulator Trigger Circuit 03P6666

The modulator trigger circuit consisting of Q850, Q854, Q853 and U850 generates pulses that fire SCRs CR813 thru CR815. Normally the circuit is stable with Q850/Q853 off. Q850 turns on upon receiving the TX trigger from the display unit and a negative going pulse is produced at its collector. Then, a positive going pulse is produced at pin #6 of U850 and sent to Q854, and then a negative going pulse is generated at the collector of Q854. The negative going pulse is differentiated by C866 and R865, and then only a negative going differentiated waveform is applied to the base of Q853. As a result, a positive going pulse (Modulator Trigger Pulse) is produced at the collector of Q853 and delivered to the modulator SCR.

The circuit made up of U850 and Q854 prevents the modulator from being fired by noise. The first stage of the one-shot multivibrator U850 operates immediately after the TX trigger pulse, then the second stage of U850 operates. The output (#9) of U850 is applied to the reset terminal (#3) of the first stage of U850. In this manner, the level at pin #6 of U850 is kept "L" while the level at pin #9 of U850 is "L". Therefore, even if noise appears after the TX trigger pulse, Q853 is kept off.

The circuit made up of U852 and U853 is a decoder to drive the relays for changing the TX pulse length depending on the setting of the RANGE selectors and MENU functions of Display Unit.

Modulator

The function of the modulator is to produce a narrow high tension pulse that drives the magnetron. It is composed of a line-type-pulser. L801 is a charging choke, which forms a series resonant Circuit with the pulse forming network (PFN) consisting of C811 thru C824, and L811. The TX high voltage in the input is doubled by the electromotive force of this coil and the PFN is charged up twice the input voltage. The time taken for full charge is roughly given by the equation $T = 2\pi\sqrt{LXC}$, where L represents the L801 and C capacitance of the PFN.

The PFN is a lumped constant L-C circuit, which is an application of parallel two-line circuits with an

open end. The modulation pulse that drives the magnetron is developed when the energy in the PFN discharges through CR813 thru CR815. The duration of the pulse is equal to the time required for the voltage wave to go and return in the L-C network, and it is given by the duration $t = 2\pi N \sqrt{L \times C}$, where N is the number of sections of the PFN.

CR801 and CR802 prevent the energy stored in the PFN from discharging to the input line. The advantage of employing CR801 and CR802 is that they allow a wide choice of CR813 thru CR815 firing timing and efficient utilization of the stored energy: CR813 thru CR815 can be fired at anytime after the PFN has been charged to a peak point and fluctuation of trigger timing does not affect the amplitude of the resultant pulse.

The pulse transformer T801 boosts up the pulse produced by the PFN. Since the characteristic impedance of the PFN and the input impedance of T801 is matched (about 3 ohms), a pulse with half the network voltage is developed across T801's.

Duplexer and Mixer

Since the radar system uses a single antenna for transmission and reception, an efficient device is required for switching between the transmitter and the receiver. This radar employs a circulator (HY801) for this purpose.

The circulator HY801 is a passive directional coupler with three ports. It contains a permanent magnet and a core of ferrite material and bends the electromagnetic waves in a specific direction. The microwave energy produced by the magnetron enters the circulator from port 2. It is bent in the specific direction and emerges from port 3 with a little loss, port 1 being isolated. In the same manner, the received signal entering into port 3 is transferred to port 1, isolating port 2. This operation of the circulator protects the receiver during transmitting and minimizes the loss of the received signal during reception.

The diode limiter is a self-activating switch made up of three PIN diodes. Its function is to attenuate the leaks of RF energy from the magnetron and from other radars through the antenna to protect the MIC (Microwave IC). The PIN diode has particular characteristic and conducts at a certain level of microwave power. When the diode is in a cut-off state, the input impedance of the diode limiter matches the characteristic impedance of the waveguide, and the microwave energy is delivered to the MIC. When the diode is put into a conductive state, the waveguide is short-circuited and most of the input energy is reflected back to the transmitter side. The strong signal is thus weakened down to about 50 mW by the diode limiter.

The MIC incorporates a local oscillator and mixer diodes and low noise amplifier. The received

microwave signal of 3050 MHz coming from the diode limiter is mixed with the local oscillation signal in the mixer diodes and converted to IF signal of 60 MHz.

IF Amplifier 03P6570

The IF signal of 60 MHz coming from the MIC is amplified and converted into a video signal, which is delivered to the Display Unit.

The IF amplifier is composed of 5 major circuits; Linear Amplifier (Q601, Q602), Logarithmic Amplifier (U601 to U609, Q604/Q605), Video Amplifier (Q606/Q607), Bandpass Selector (Q611 to Q613, CR601 to CR606) and Tuning Indicator Circuit (Q609/Q610, U610/U611).

The signal applied to the base of Q601 is amplified in cascade by Q601 and Q602 and sent to the bandpass selector via T602.

The IF amplifier operates in either narrow or wide bandwidth mode depending on the settings of the RANGE selector and TX touchpad. For short ranges, a wide bandwidth (27 MHz) is selected, since the levels at the base of Q612 and the cathode of CR614 go high, thus CR602 to CR605 are conductive and CR601/CR606 are cut off, causing the signal to pass through CR603/CR604. On the contrary, CR602 to CR605 are cut off and CR601/CR606 are conductive, which causes the signal to pass through T603/T604, selecting a narrow bandwidth (3 MHz) on middle and long ranges.

The signal thru the bandpass selector is coupled to the logarithmic amplifier and amplified by U601 to U607 and Q604/Q605. Thus, the output signals of Q604/Q605 are fed to Q606/Q607 to be amplified further, and then sent to the Display Unit.

The IF signal of 60 MHz is amplified by Q609/U610 and detected by U611. Then the detected signal (Turning Indicator Signal) is sent to the Display Unit via Q610.

On the other hand, Q609/U610 and U608/U609 are additional amplifier circuits to make the dynamic range of the IF signal wider, causing the discrimination of the target echoes to get better. The IF signal from the MIC is fed to Q609 as well as thru resistors R636/R639 which are employed to attenuate the signal level.

Therefore, Q609/U610 amplifies even a strong signal which may be saturated in Q601/Q602 and U601 to U607, and then sent to logarithmic amplifier U608/U609. This signal is added to the

saturated signal in U601 to U607, causing the saturation level of the IF signal to become high.

The MBS (Main Bang Suppression) waveform is fed to the base of Q603 and the emitter of Q601 thru Q603, then Q603 and Q601 turn on and off respectively so as to eliminate the strong transmission signal (main bang).

Main Bang Suppression 03P6569

The purpose of this board is to minimize transmission leakage near the center spot on the screen. It includes operational amplifier U501 for "Di MONITOR" signal and +5V regulator U502 for MIC.

Then the TX trigger is fed to pin #4 of one-shot multivibrator U503, pin #6 of U503 produces a positive going pulse. This pulse is mixed with the TX trigger pulse through CR508 to compensate for delay time caused by U503-1/2. Since the cathode voltage of CR510 is determined by the MBS-T signal on the SPU board of Display Unit, the charging curve for C517 varies depending on the setting of the MBS-T signal. At the moment the charging curve exceeds the threshold level of U503-2/2, a positive going pulse is produced at pin #10 of U503 and differentiated by C523 and R531. Since the cathode voltage of CR515 is determined by the MBS-L signal on the SPU board of Display Unit, the level of the differentiated waveform is passed through C520 and Q501 and applied to the base of Q603 on the IF AMPLIFIER board as a main bang suppression waveform.

Bearing Signal Generator MP-3795

The bearing signal generator produces a square wave signal that is used to synchronize the sweep rotation with that of the antenna.

U901 is a photo interrupter composed of a light emitting diode and a photo transistor. It has a U-shaped construction. The light emitting diode is mounted on one wall of the "U" shape and the photo transistor on the other wall. A rotating timing disc is arranged between the two walls.

The timing disc is provided with 60 slits at regular intervals along its circumference. It is fitted on the scanner motor shaft and rotates at a speed of 144 rpm.

The photo transistor receives the light emitted by the light emitting diode thru each slit of the timing disc and converts it into electric currents. The output of the photo transistor across R903 is a half-rectified sine wave at a frequency of 144 kHz. This signal is amplified, reshaped and sent to the Display Unit for display echo synchronization.

Sensitivity Time Control ATT-7362

If the received signal enters the MIC at too high a level, the signal saturates making it impossible to differentiate signal strengths.

To prevent saturation of the output signals of the MIC and IF amplifier, the received signal is attenuated before entering the MIC by a PIN diode just in the same way as an STC circuit.

The circuit composed of Q1, Q2, U1, U2, C7 - C10 and R9 to R11 generates an STC waveform in synchronism with trigger pulses and feeds a current into the PIN diode of limiter RU-7394 through Q4 and Q5 to attenuate the incoming signal.

Motor Soft Starter MSS-7737

This is motor slow-start control circuit for protection of the scanner motor.

LABOTECH

Furuno Labotech International

Report no. : FLI 12-98-017

12 OPERATOR'S MANUAL INCL. CIRCUIT DIAGRAMS (FCC Rule § 2.983)

(See separate covers)

ATTACHMENT 1

[TEST DATA FOR 6. SPURIOUS EMISSIONS AT ANTENNA TERMINALS]

1. Spurious emissions for 0.125 nm Range:

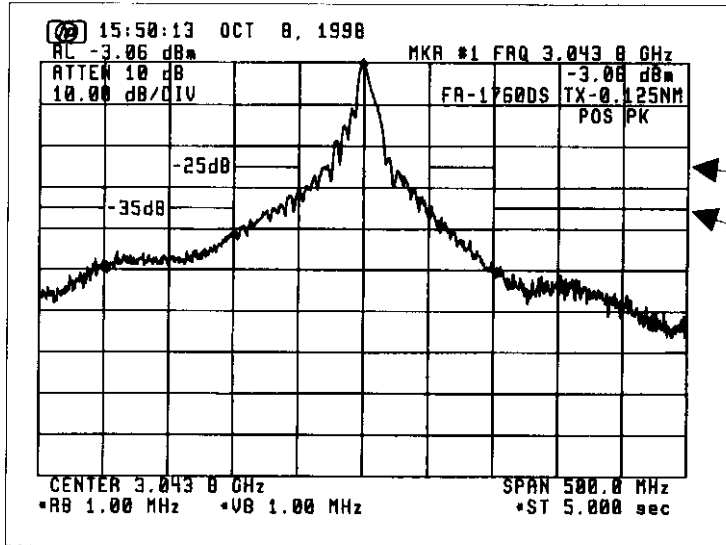

Ref. level: -3.06 dBm

Emission limitations:

- (a) 25 dB for 50 to 100 % of the authorized BW (100 MHz)
- (b) 35 dB for 100 to 250 % of the authorized BW (100 MHz)

Fig. 1.1 Without Filter

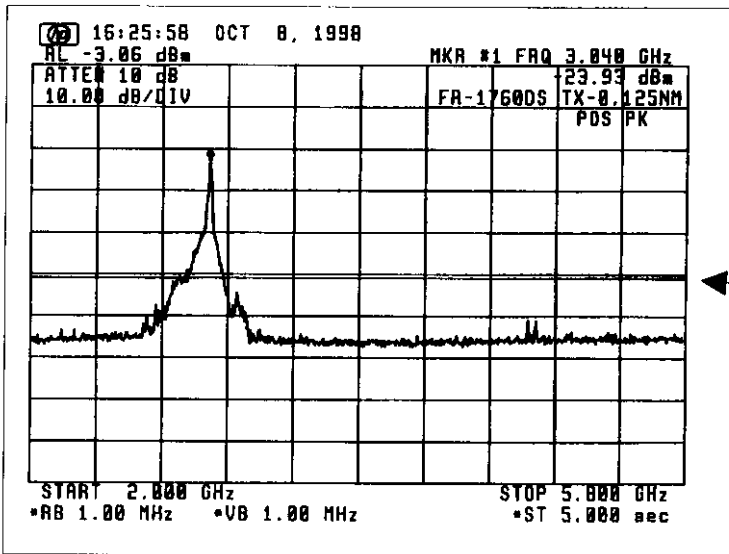

Emission limitations:

- (c) $43 + 10 \log P_m = 50.53 \text{ dB}$ for more than 250 % of the authorized BW (100 MHz)

Fig. 1.2 With Filter No.1

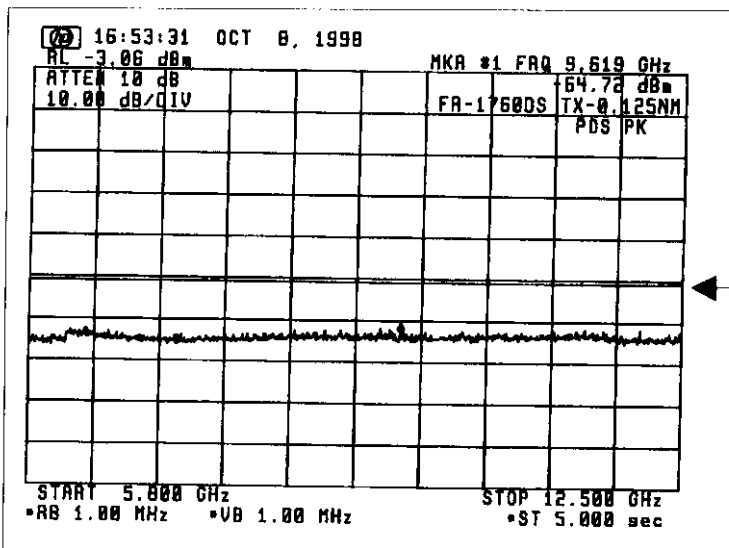

Emission limitations:

- (c) $43 + 10 \log P_m = 50.53 \text{ dB}$ for more than 250 % of the authorized BW (100 MHz)

Fig. 1.3 With Filter No. 2

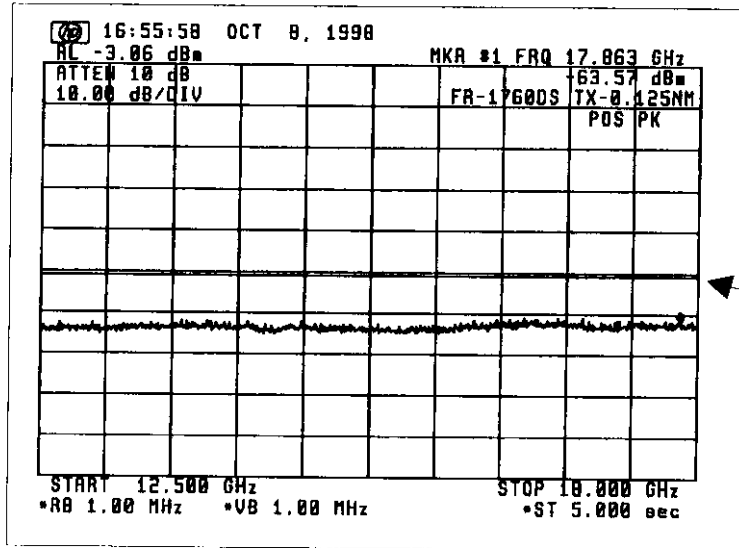

Emission limitations:

- (c) $43 + 10 \log P_m = 50.53 \text{ dB}$
for more than 250 % of
the authorized BW (100 MHz)

Fig. 1.4 With Filter No. 2

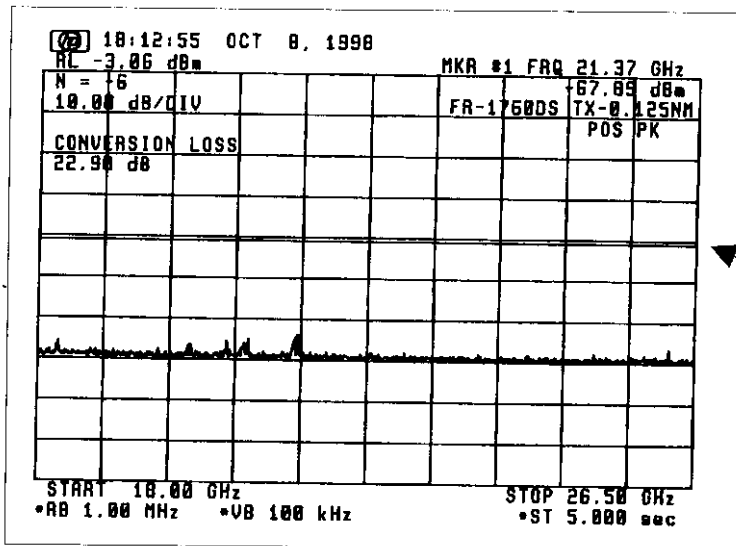

Emission limitations:

- (c) $43 + 10 \log P_m = 50.53 \text{ dB}$
for more than 250 % of
the authorized BW (100 MHz)

Fig. 1.5 With Filter No. 2

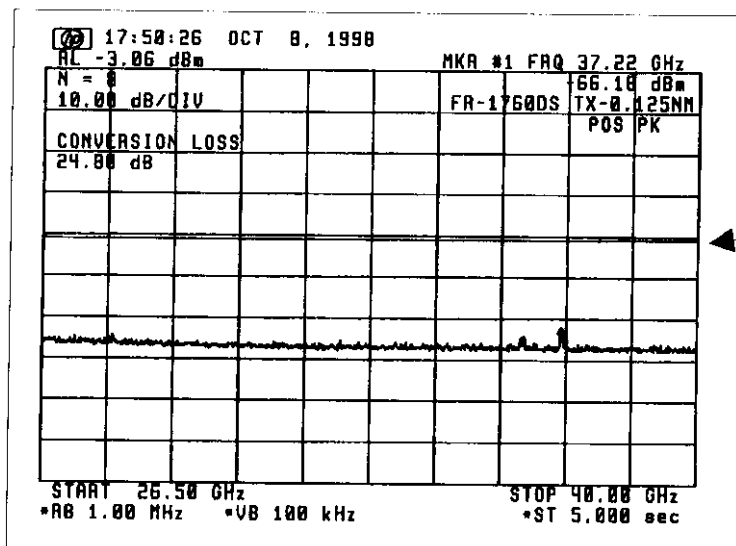

Emission limitations:

- (c) $43 + 10 \log P_m = 50.53 \text{ dB}$
for more than 250 % of
the authorized BW (100 MHz)

Fig. 1.6 With Filter No. 2

2. Spurious emissions for 3 nm Range:

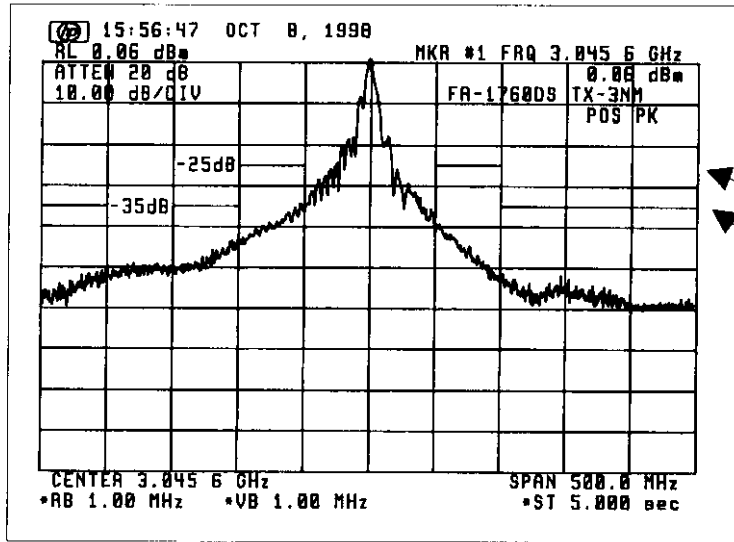

Ref. level: 0.06 dBm

Emission limitations:

- (a) 25 dB for 50 to 100 % of the authorized BW (100 MHz)
- (b) 35 dB for 100 to 250 % of the authorized BW (100 MHz)

Fig. 2.1 Without Filter

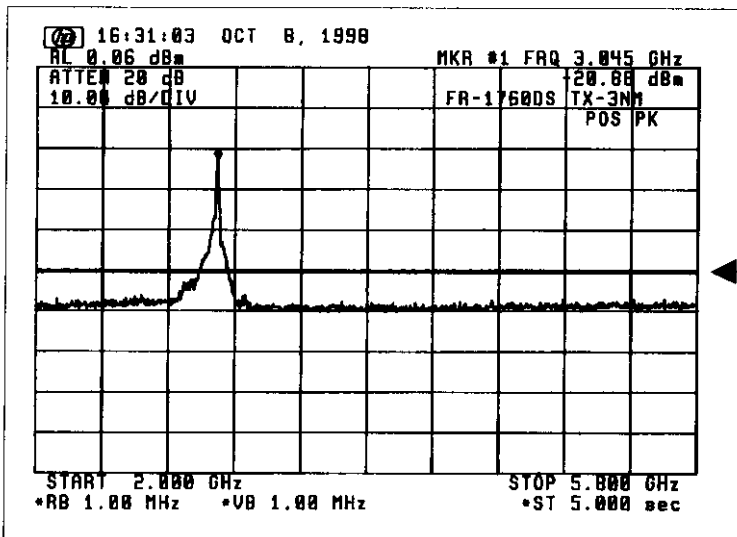

Emission limitations:

- (c) $43 + 10 \log P_m = 50.3$ dB for more than 250 % of the authorized BW (100 MHz)

Fig. 2.2 With Filter No.1

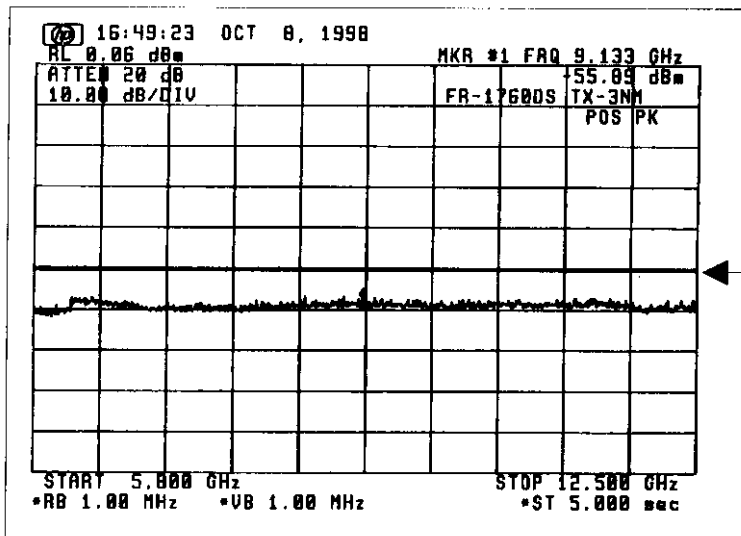

Emission limitations:

- (c) $43 + 10 \log P_m = 50.3$ dB for more than 250 % of the authorized BW (100 MHz)

Fig. 2.3 With Filter No. 2

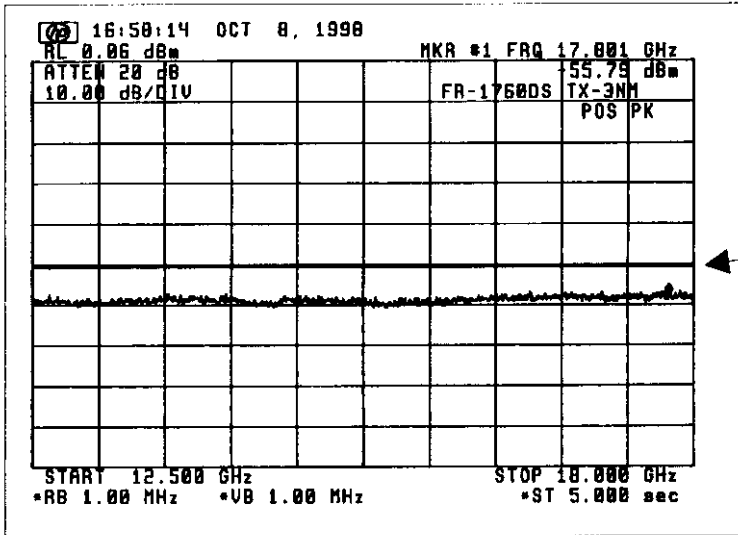

Emission limitations:

- (c) $43 + 10 \log P_m = 50.3 \text{ dB}$
for more than 250 % of
the authorized BW (100 MHz)

Fig. 2.4 With Filter No. 2

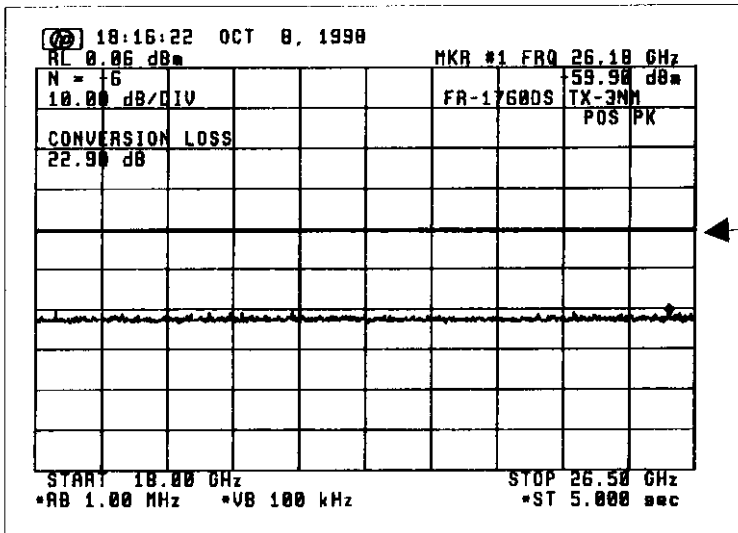

Emission limitations:

- (c) $43 + 10 \log P_m = 50.3 \text{ dB}$
for more than 250 % of
the authorized BW (100 MHz)

Fig. 2.5 With Filter No. 2

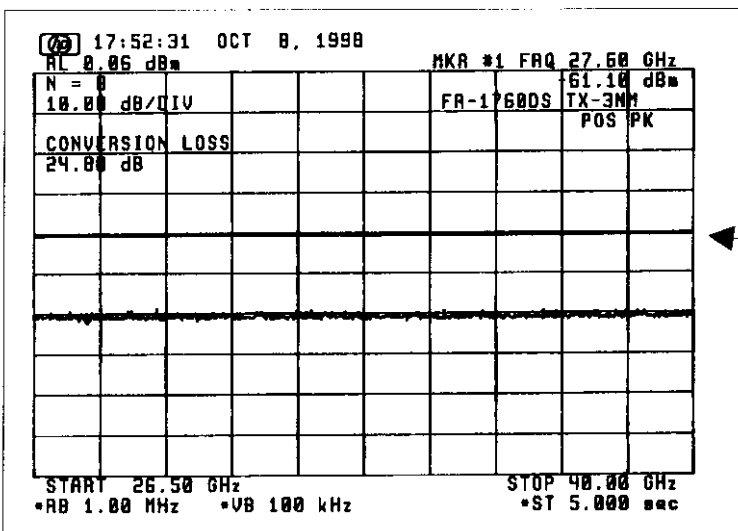

Emission limitations:

- (c) $43 + 10 \log P_m = 50.3 \text{ dB}$
for more than 250 % of
the authorized BW (100 MHz)

Fig. 2.6 With Filter No. 2

3. Spurious emissions for 12 nm Range:

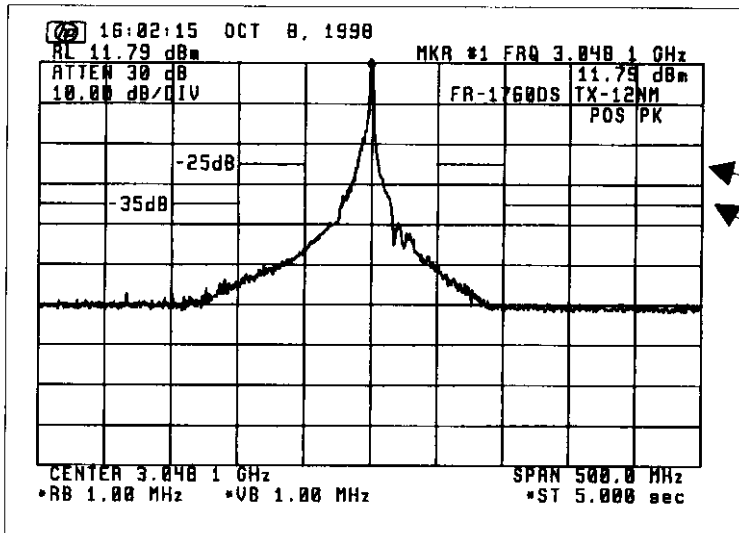

Ref. level: 11.79 dBm

Emission limitations:

- (a) 25 dB for 50 to 100 % of the authorized BW (100 MHz)
- (b) 35 dB for 100 to 250 % of the authorized BW (100 MHz)

Fig. 3.1 Without Filter

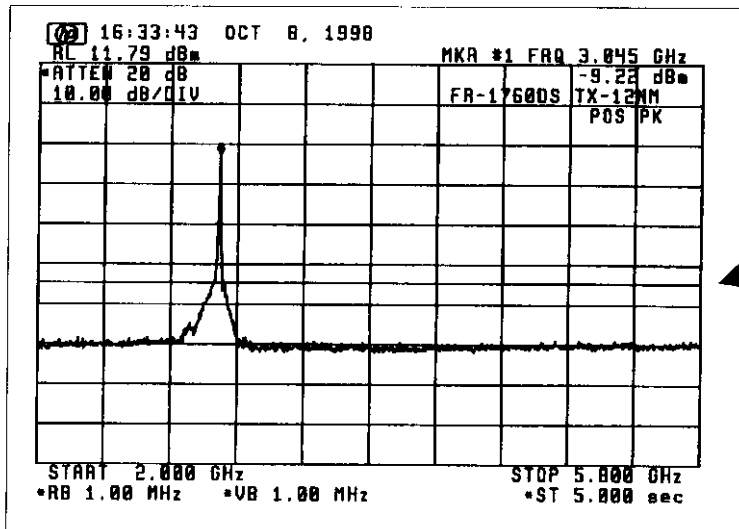

Emission limitations:

- (c) $43 + 10 \log P_m = 54.31 \text{ dB}$ for more than 250 % of the authorized BW (100 MHz)

Fig. 3.2 With Filter No.1

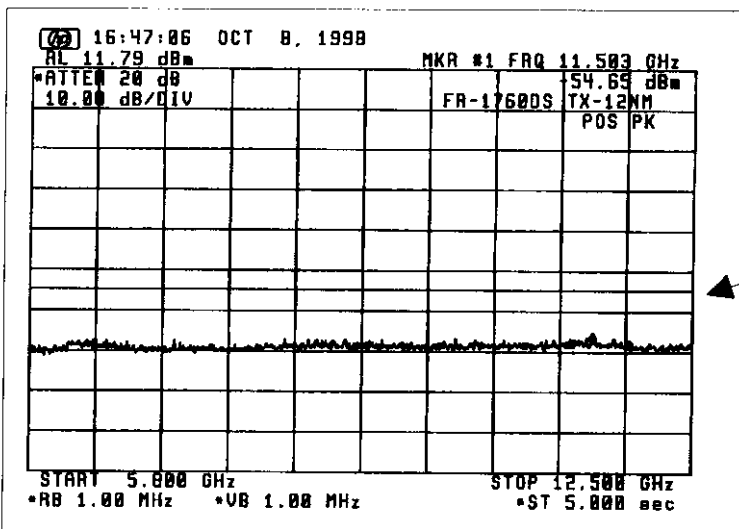

Emission limitations:

- (c) $43 + 10 \log P_m = 54.31 \text{ dB}$ for more than 250 % of the authorized BW (100 MHz)

Fig. 3.3 With Filter No. 2

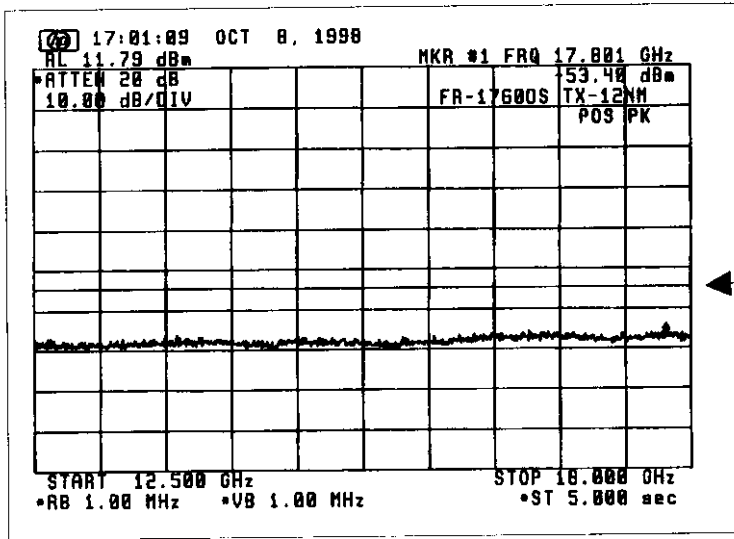

Emission limitations:

- (c) $43 + 10 \log P_m = 54.31 \text{ dB}$
for more than 250 % of
the authorized BW (100 MHz)

Fig. 3.4 With Filter No. 2

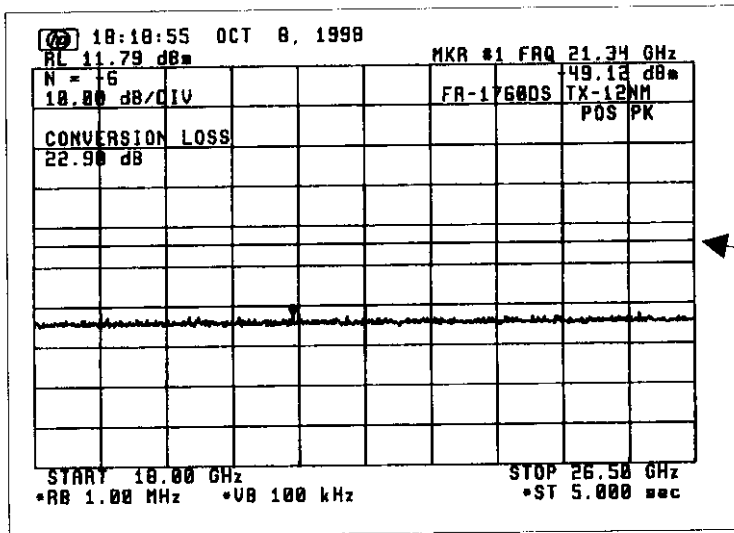

Emission limitations:

- (c) $43 + 10 \log P_m = 54.31 \text{ dB}$
for more than 250 % of
the authorized BW (100 MHz)

Fig. 3.5 With Filter No. 2

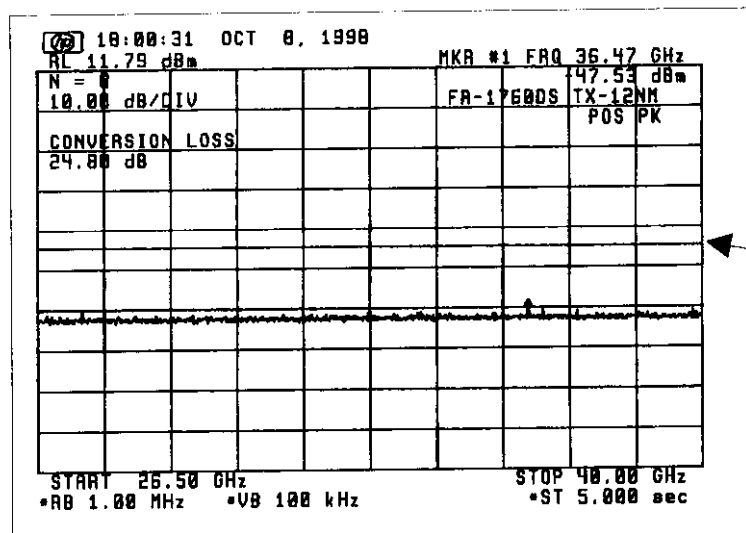

Emission limitations:

- (c) $43 + 10 \log P_m = 54.31 \text{ dB}$
for more than 250 % of
the authorized BW (100 MHz)

Fig. 3.6 With Filter No. 2

4. Spurious emissions for 48 nm Range:

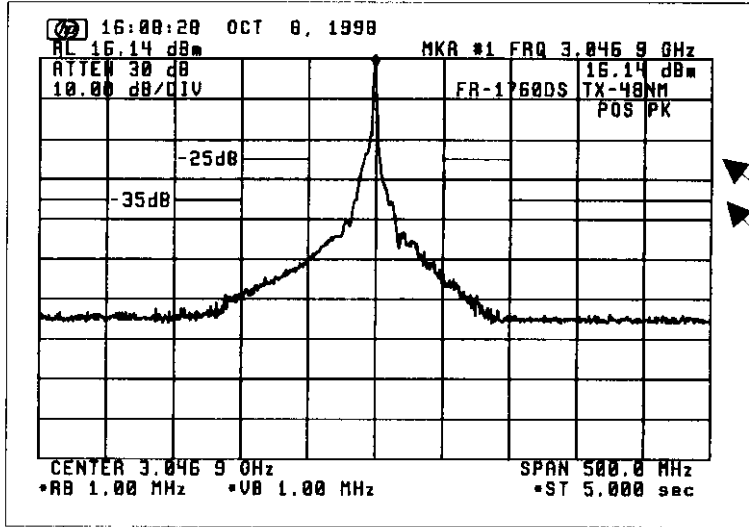

Ref. level: 16.14 dBm

Emission limitations:

- (a) 25 dB for 50 to 100 % of the authorized BW (100 MHz)
- (b) 35 dB for 100 to 250 % of the authorized BW (100 MHz)

Fig. 4.1 Without Filter

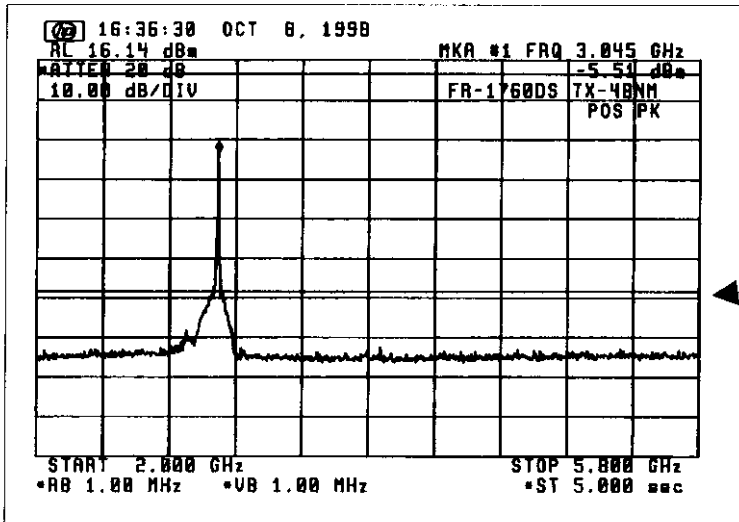

Emission limitations:

- (c) $43 + 10 \log P_m = 58.05 \text{ dB}$ for more than 250 % of the authorized BW (100 MHz)

Fig. 4.2 With Filter No.1

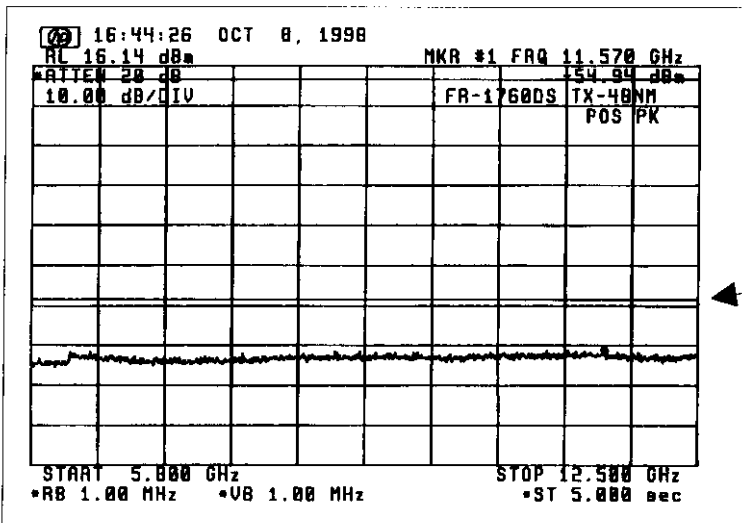

Emission limitations:

- (c) $43 + 10 \log P_m = 58.05 \text{ dB}$ for more than 250 % of the authorized BW (100 MHz)

Fig. 4.3 With Filter No. 2

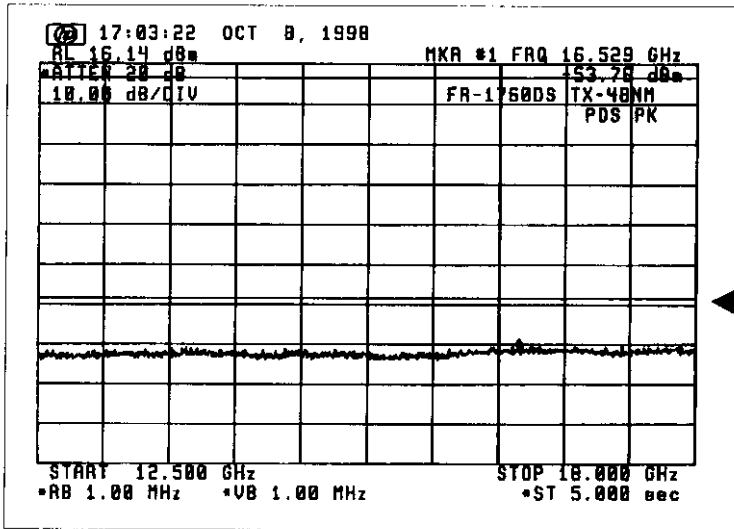

Emission limitations:

- (c) $43 + 10 \log P_m = 58.05 \text{ dB}$
 for more than 250 % of
 the authorized BW (100 MHz)

Fig. 4.4 With Filter No. 2

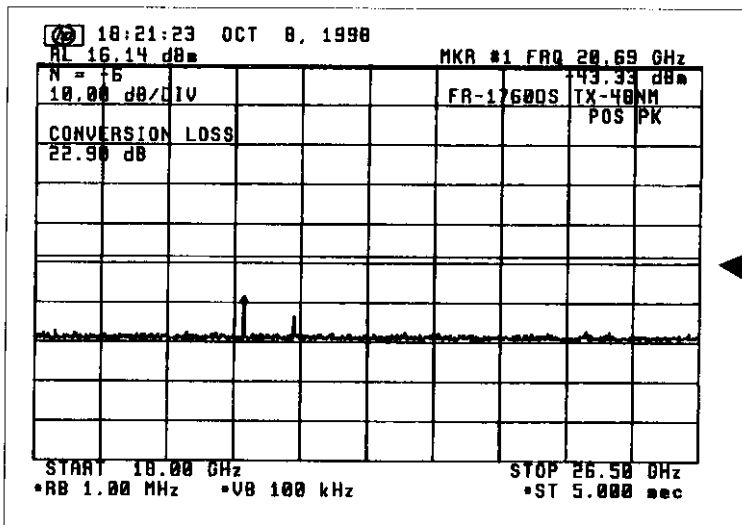

Emission limitations:

- (c) $43 + 10 \log P_m = 58.05 \text{ dB}$
 for more than 250 % of
 the authorized BW (100 MHz)

Fig. 4.5 With Filter No. 2

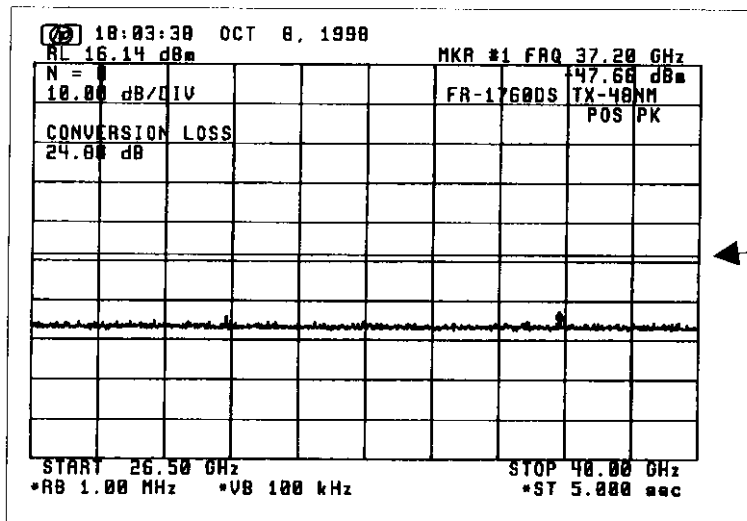

Emission limitations:

- (c) $43 + 10 \log P_m = 58.05 \text{ dB}$
 for more than 250 % of
 the authorized BW (100 MHz)

Fig. 4.6 With Filter No. 2

5. Spurious emissions for 120 nm Range:

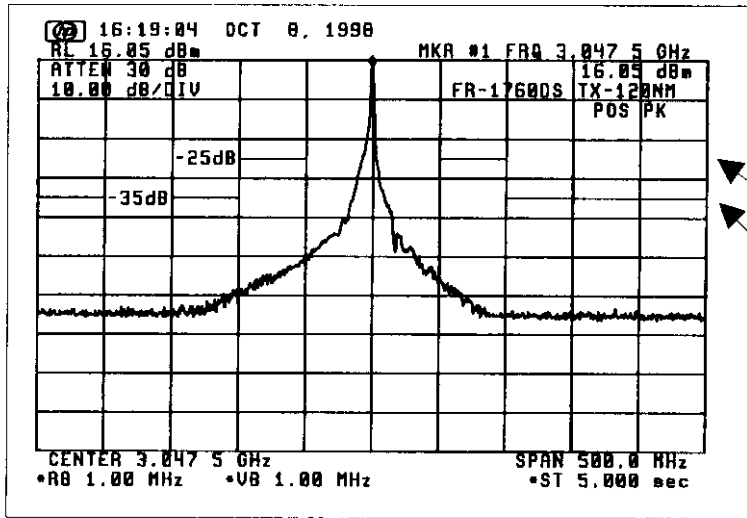

Ref. level: 16.05 dBm

Emission limitations:

- (a) 25 dB for 50 to 100 % of the authorized BW (100 MHz)
- (b) 35 dB for 100 to 250 % of the authorized BW (100 MHz)

Fig. 5.1 Without Filter

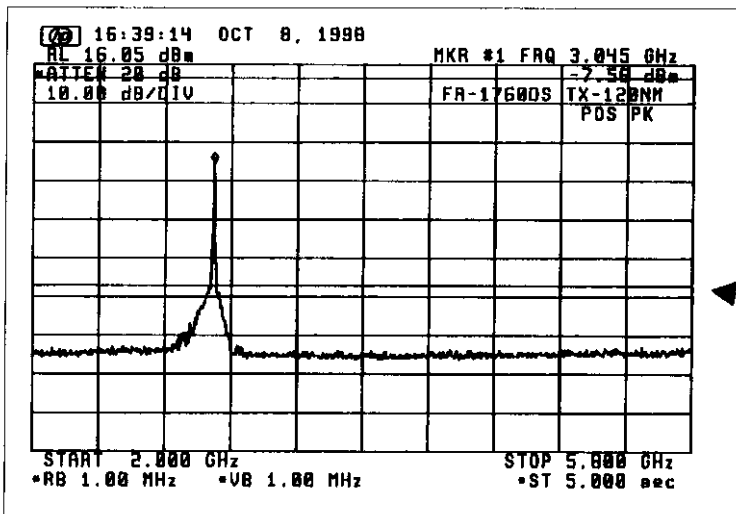

Emission limitations:

- (c) $43 + 10 \log P_m = 56.81$ dB for more than 250 % of the authorized BW (100 MHz)

Fig. 5.2 With Filter No.1

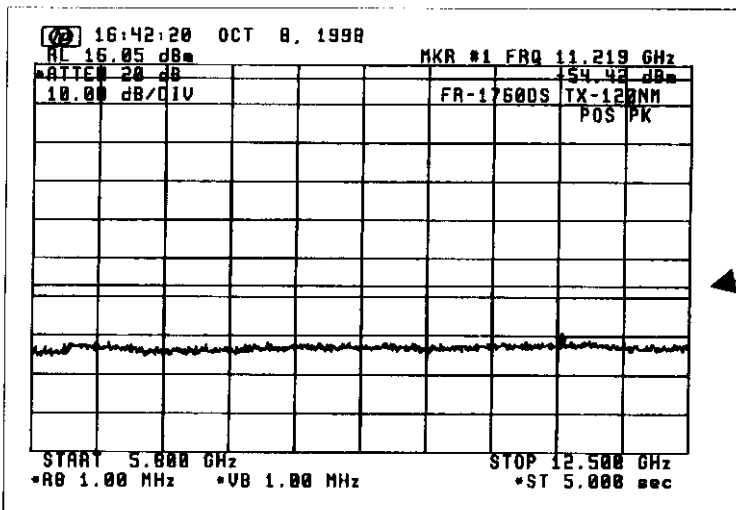

Emission limitations:

- (c) $43 + 10 \log P_m = 56.81$ dB for more than 250 % of the authorized BW (100 MHz)

Fig. 5.3 With Filter No. 2

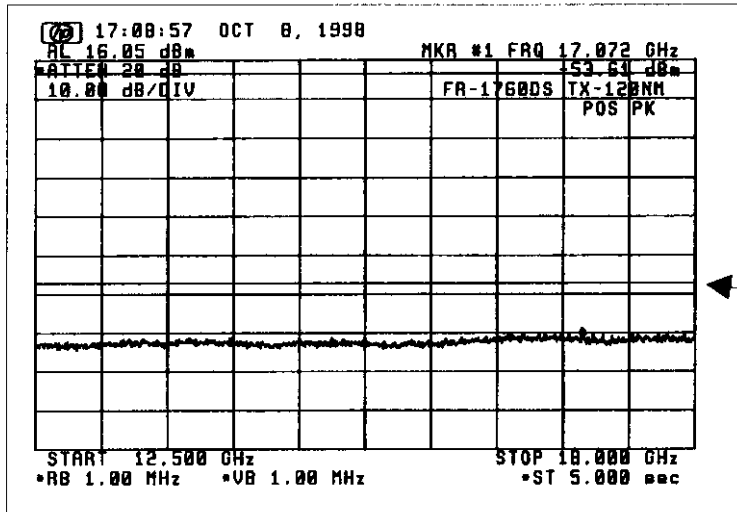

Emission limitations:

- (c) $43 + 10 \log P_m = 56.81 \text{ dB}$
for more than 250 % of
the authorized BW (100 MHz)

Fig. 5.4 With Filter No. 2

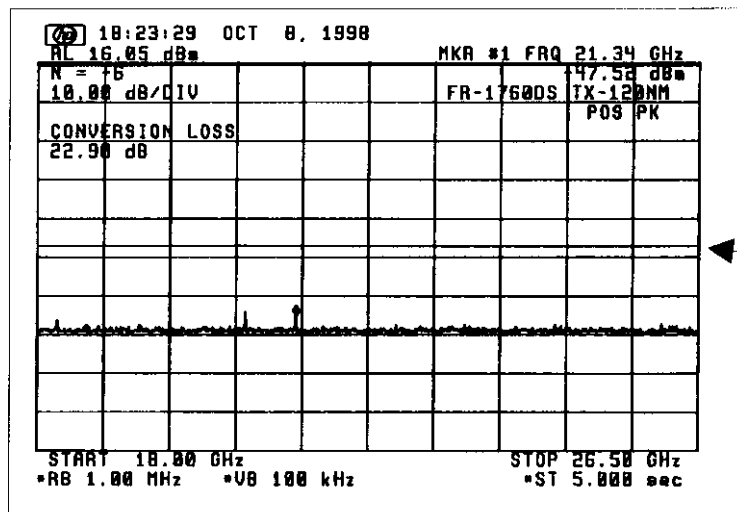

Emission limitations:

- (c) $43 + 10 \log P_m = 56.81 \text{ dB}$
for more than 250 % of
the authorized BW (100 MHz)

Fig. 5.5 With Filter No. 2

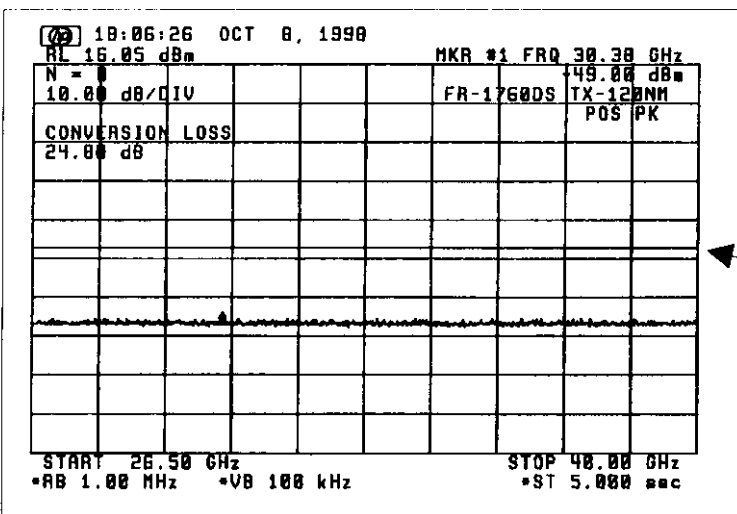

Emission limitations:

- (c) $43 + 10 \log P_m = 56.81 \text{ dB}$
for more than 250 % of
the authorized BW (100 MHz)

Fig. 5.6 With Filter No. 2

ATTACHMENT 2 [TEST DATA FOR 7. FIELD STRENGTH OF SPURIOUS RADIATION]

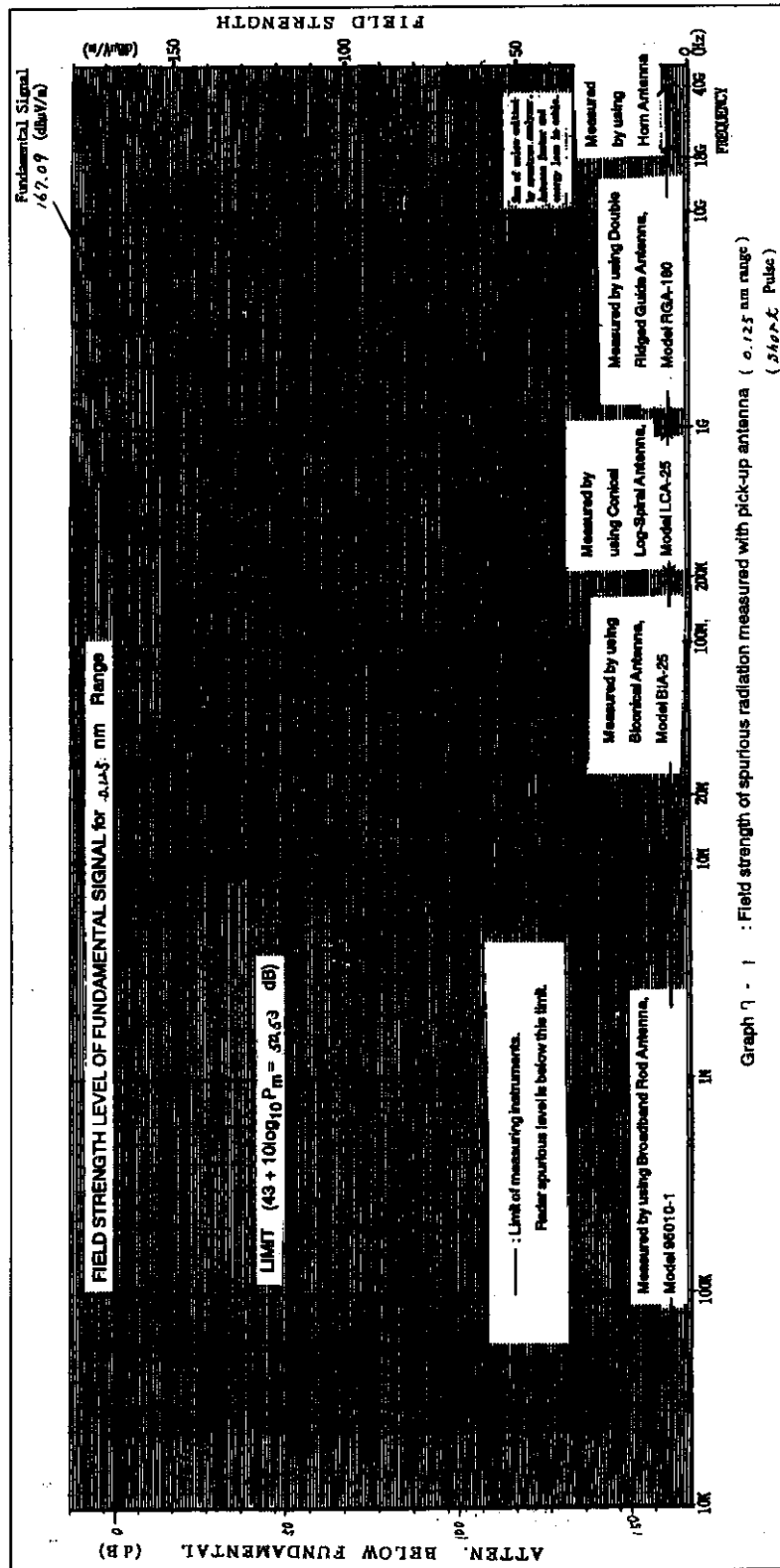

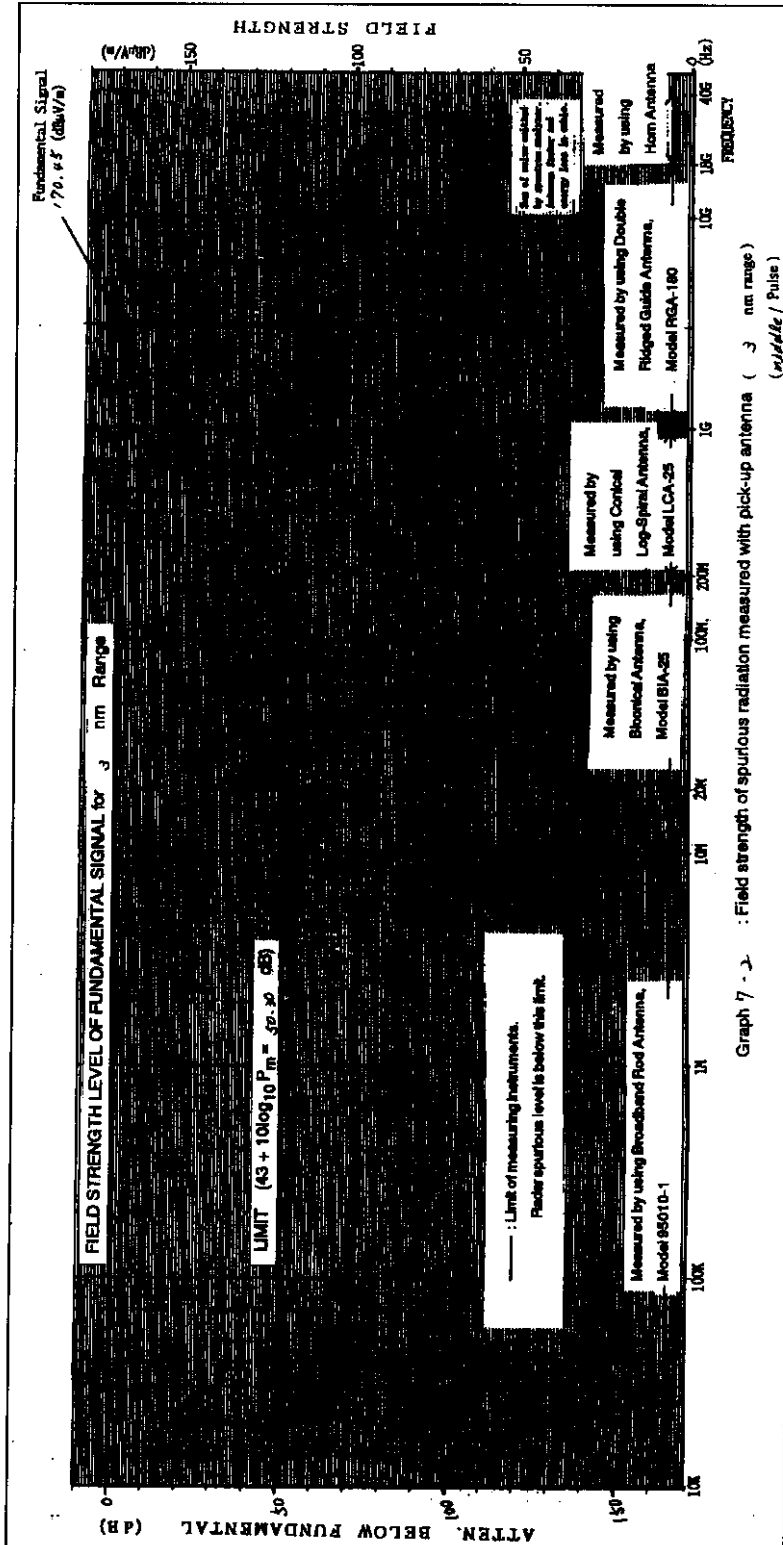

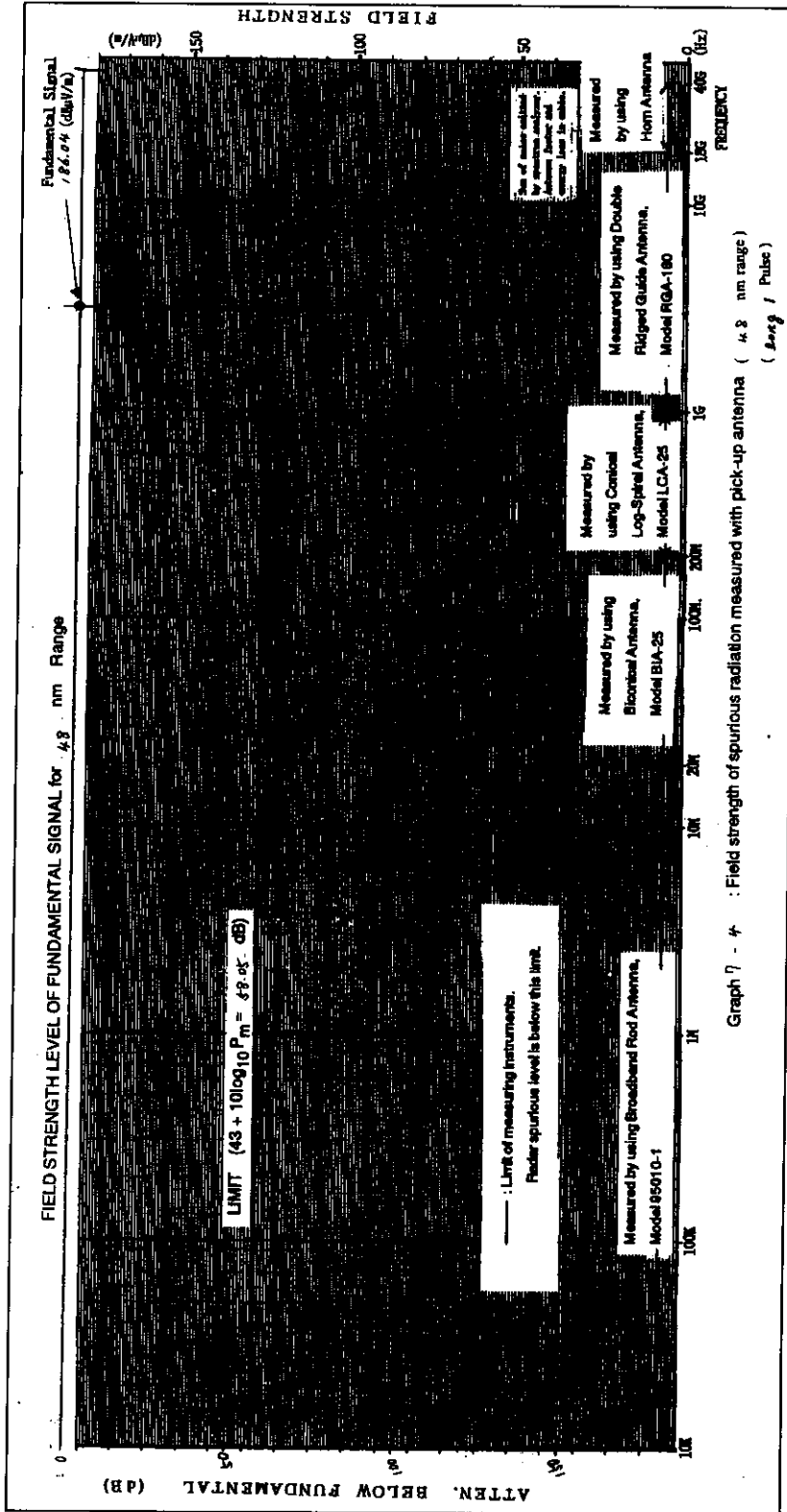

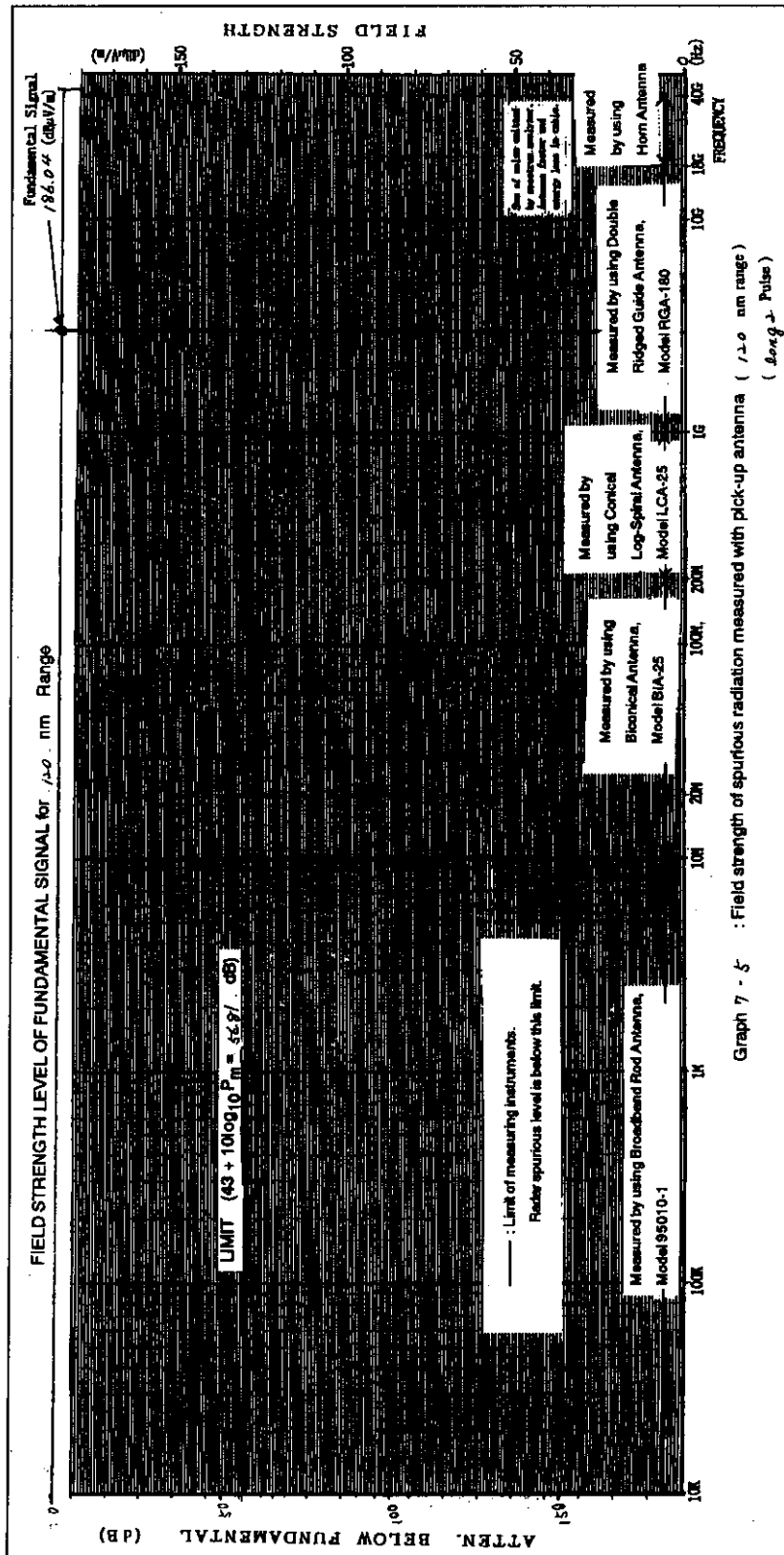

ATTACHMENT 3

[TEST DATA FOR 9. SUPPRESSION OF INTERFERENCE ABOARD SHIPS]

1. Harmful Interference to Receiver

(Band : 14 kHz - 490 kHz)

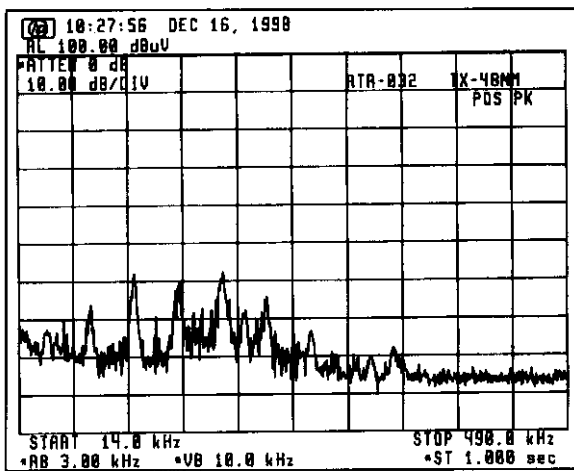
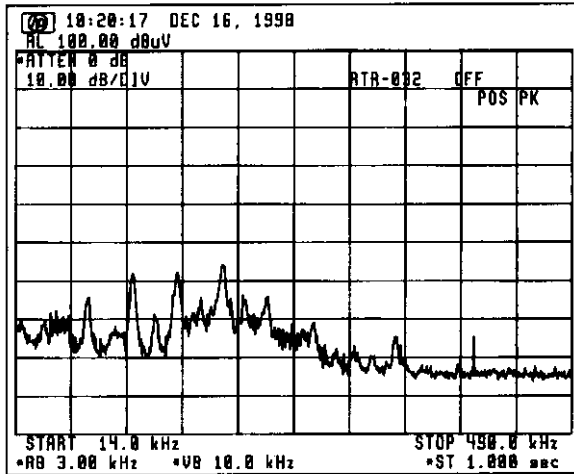

(Band : 490 kHz - 5 MHz)

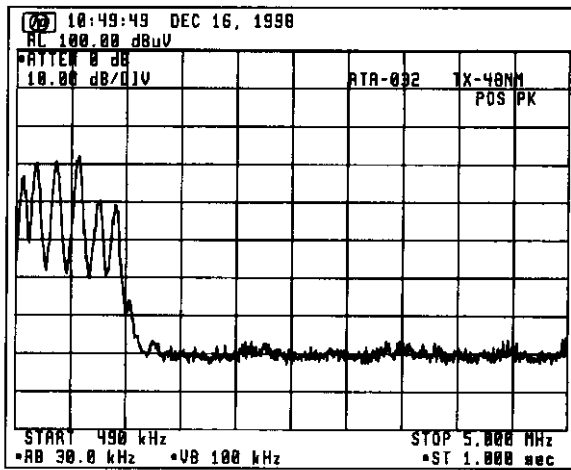
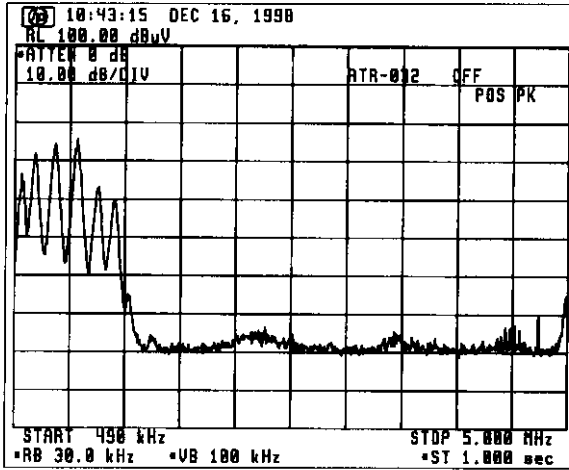

(Band : 5 MHz - 10 MHz)

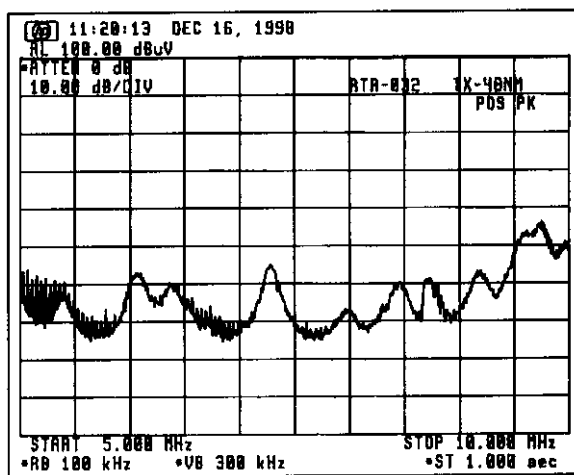
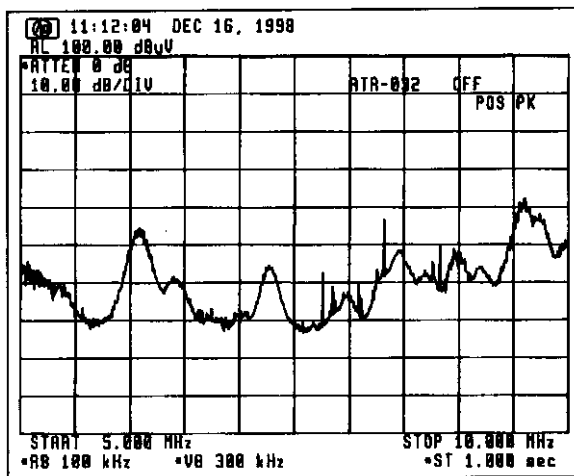

(Band : 10 MHz - 30 MHz)

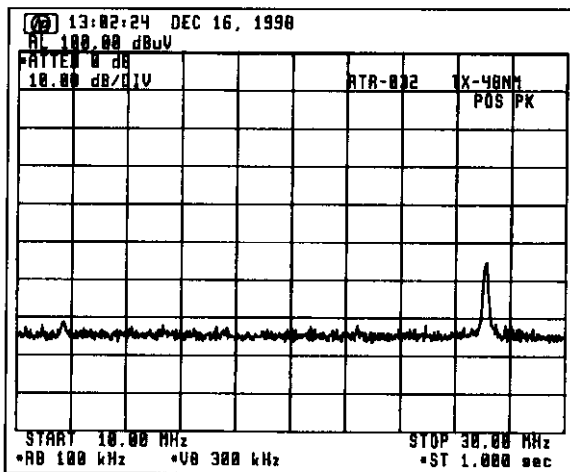
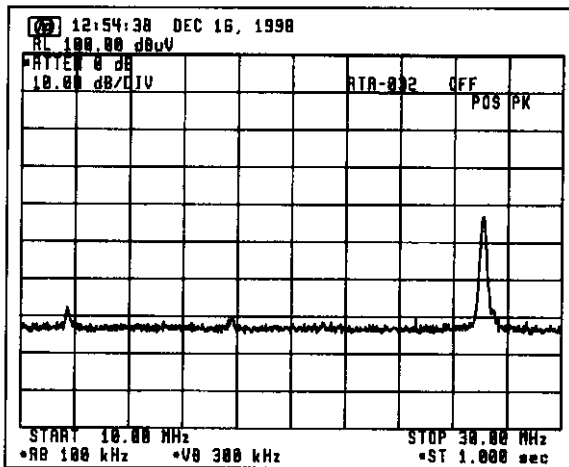

(Band : 30 MHz - 100 MHz)

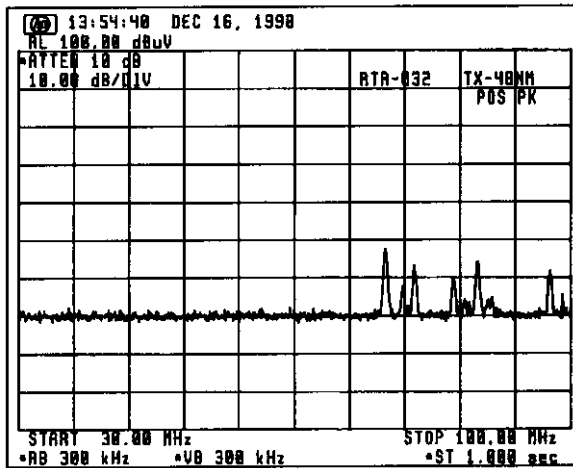
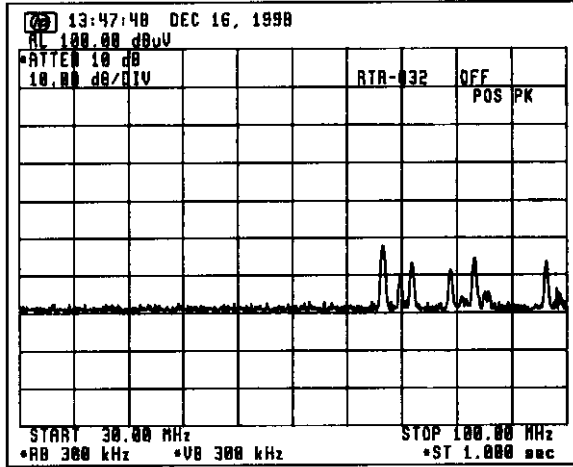

(Band : 100 MHz - 300 MHz)

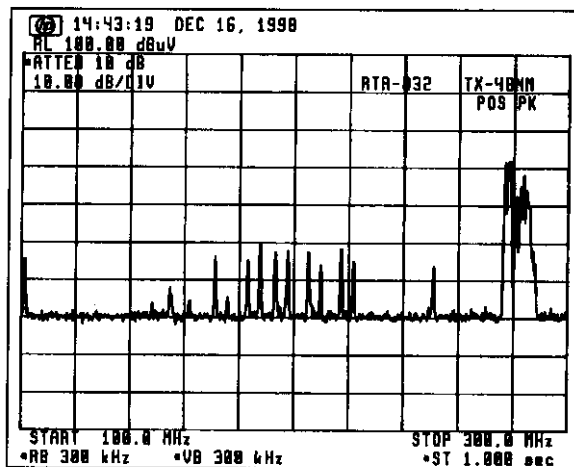
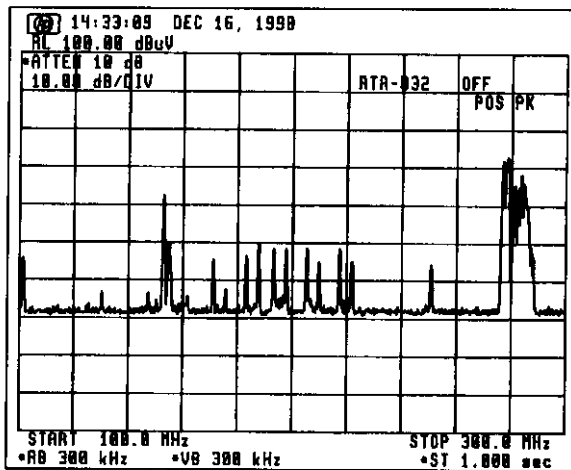

(Band : 300 MHz - 1 GHz)

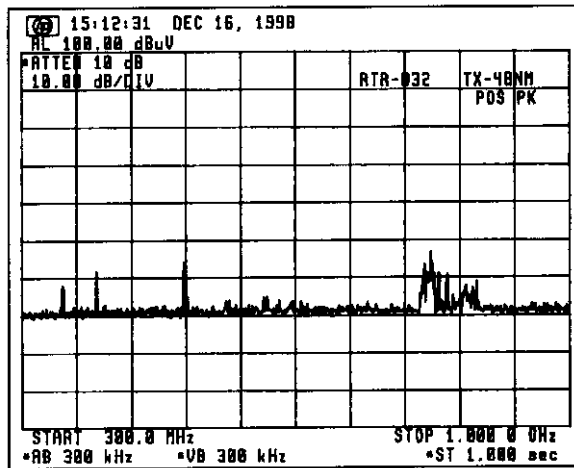
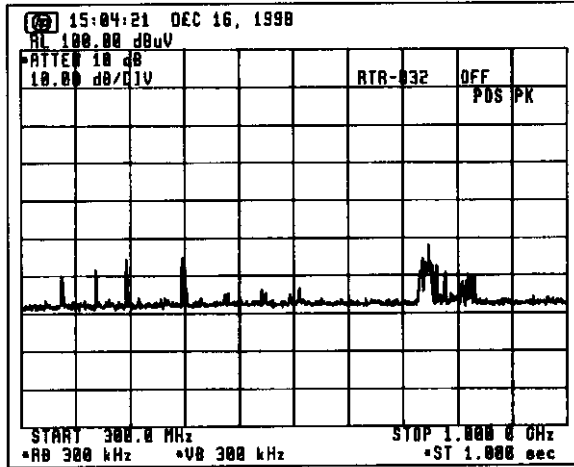

2. Electromagnetic Field

(Band : 14 kHz - 490 kHz, Limit at 1 nm = 0.1 $\mu\text{V}/\text{m}$ = -20 $\text{dB}\mu\text{V}/\text{m}$)

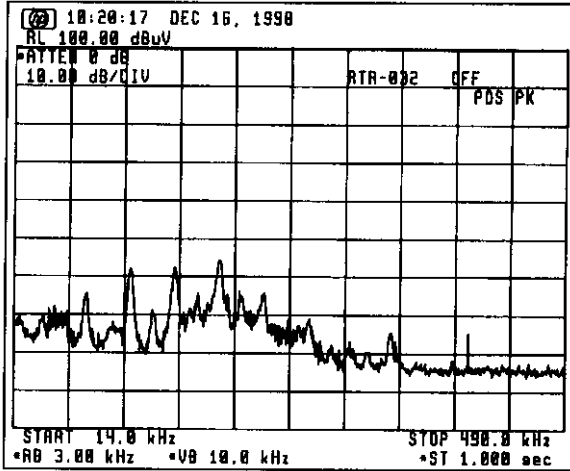

-26 $\text{dB}\mu\text{V}/\text{m}$

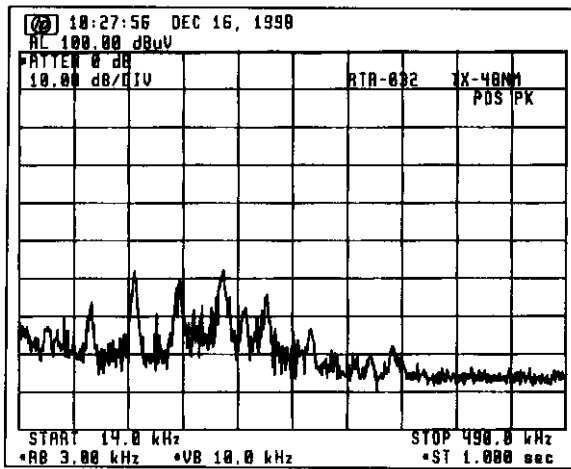

-26 $\text{dB}\mu\text{V}/\text{m}$

(Band : 490 kHz - 5 MHz, Limit at 1 nm = 0.1 μ V/m = -20 dB μ V/m)

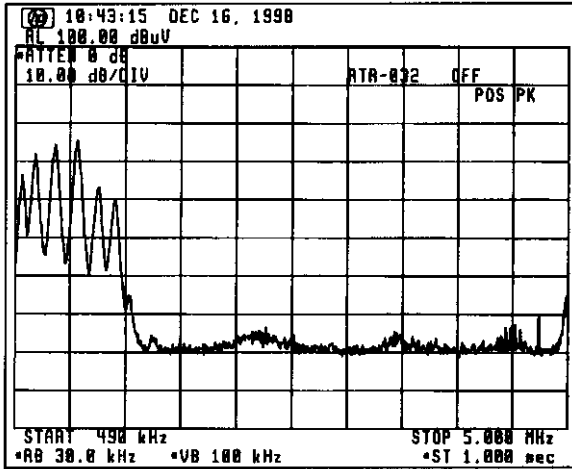

Ref. level (dB μ V/m)
 = 126 - 100 = 26 (at 0.5 MHz)
 = 100 - 96 = 4 (at 3 MHz)
 = 100 - 88 = 12 (at 5 MHz)

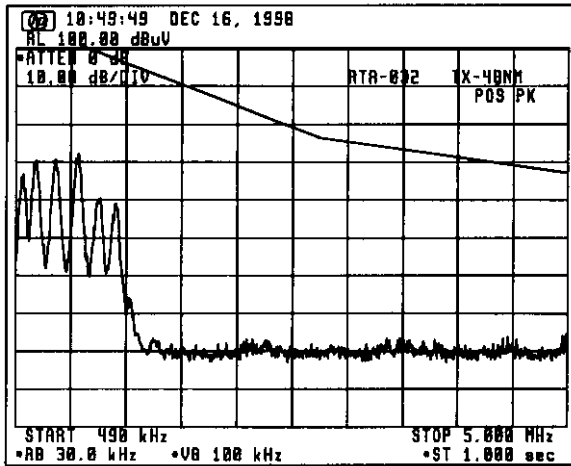

-20 dB μ V/m limit line

(Band : 5 MHz - 10 MHz, Limit at 1 nm = 0.1 $\mu\text{V}/\text{m}$ = -20 dB $\mu\text{V}/\text{m}$)

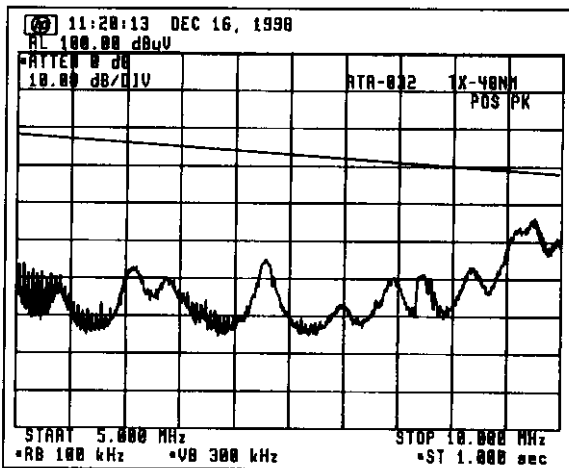
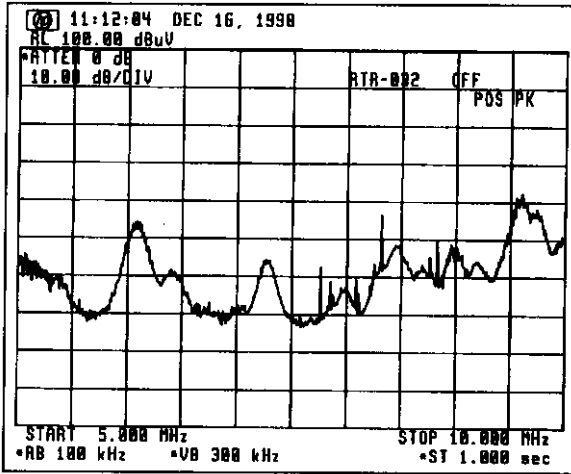

Ref. level (dB $\mu\text{V}/\text{m}$)
 = 100 - 88 = 12 (at 5 MHz)
 = 100 - 83 = 17 (at 7 MHz)
 = 100 - 78 = 22 (at 10 MHz)

-20 dB $\mu\text{V}/\text{m}$ limit line

(Band : 10 MHz - 30 MHz, Limit at 1 nm = 0.1 μ V/m = -20 dB μ V/m)

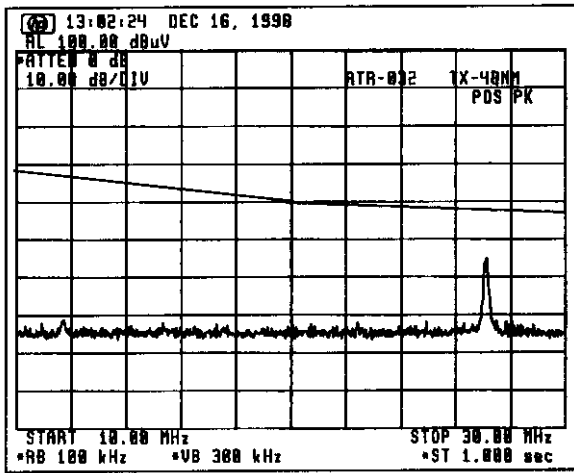
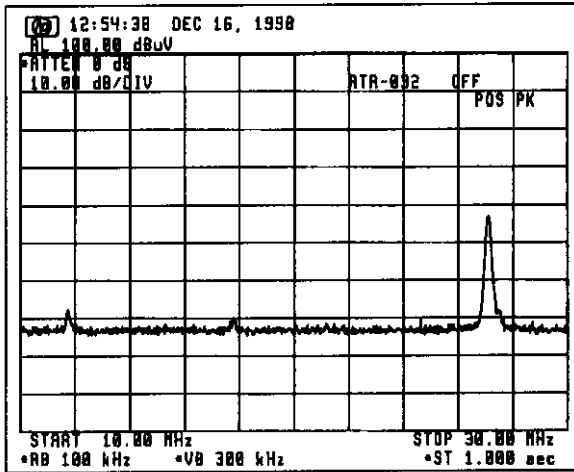

Ref. level (dB μ V/m)
 = 100 - 78 = 22 (at 10 MHz)
 = 100 - 70 = 30 (at 20 MHz)
 = 100 - 67 = 33 (at 30 MHz)

-20 dB μ V/m limit line

(Band : 30 MHz - 100 MHz, Limit at 1 nm = 0.1 μ V/m = -10.5 dB μ V/m)

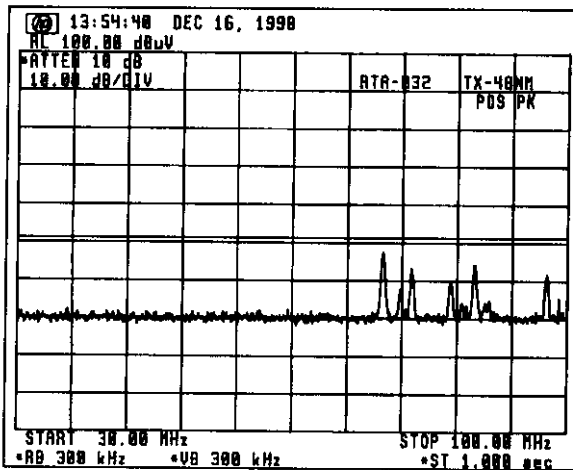
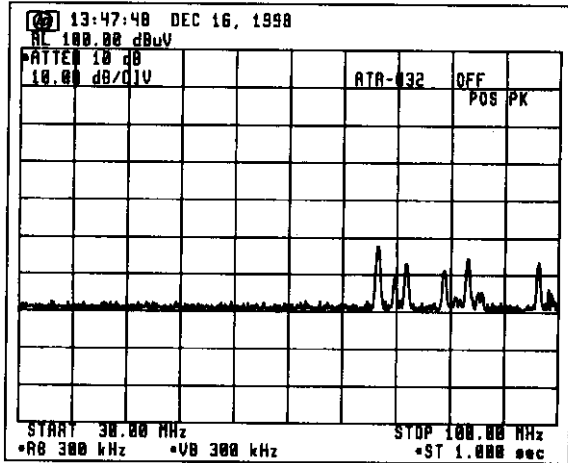

Ref. level (dB μ V/m)
 = 100 - 61 = 39

- 10.5 dB μ V/m limit line

(Band : 100 MHz - 300 MHz, Limit at 1 nm = 0.1 μ V/m = -0 dB μ V/m)

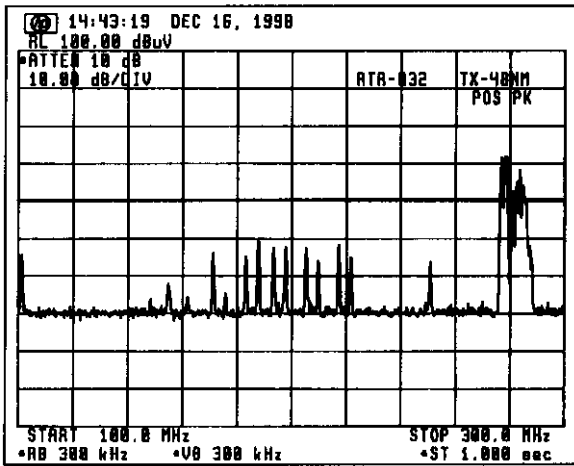
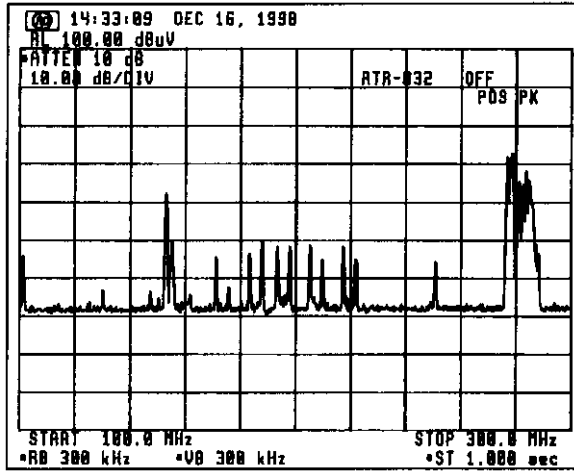

Ref. level (dB μ V/m)
 = 100 - 60 = 40

0 dB μ V/m limit line

All components above the limit
 are from external noise or
 signals, not from RADAR.

(Band : 300 MHz - 1 GHz, Limit at 1 nm = 3 μ V/m = -9.5 dB μ V/m)

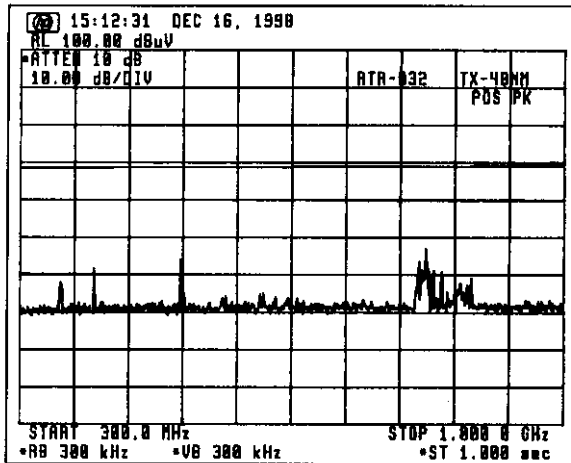
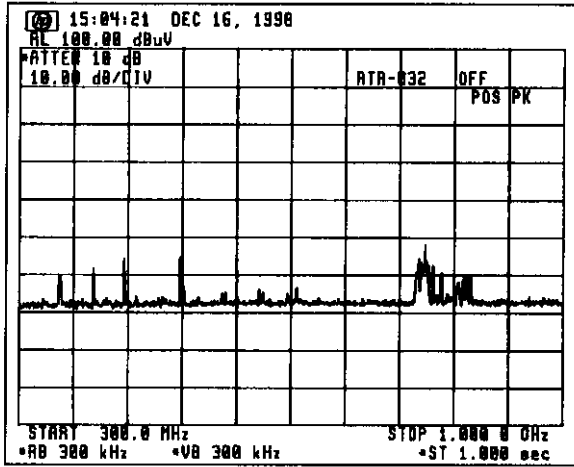

Ref. level (dB μ V/m)
 = 100 - 59.5 = 40.5

9.5 dB μ V/m limit line

3. Power Input to an Artificial Antenna

(Band : 14 kHz - 490 kHz, Limit at 2 m = -81 dBm)

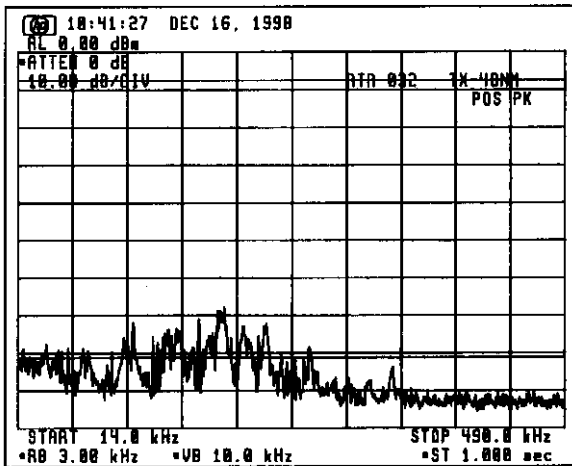
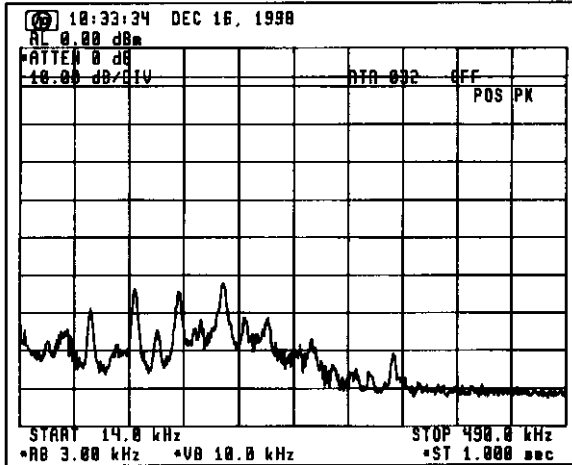

-81 dBm limit line

All components above the limit
are from external noise or
signals, not from RADAR.

(Band : 490 kHz - 5 MHz, Limit at 2 m = -81 dBm)

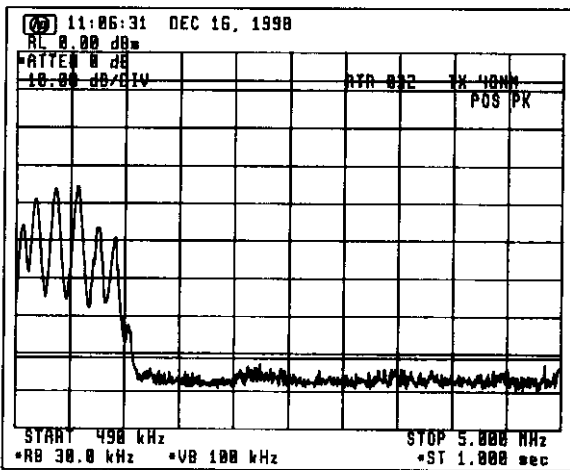
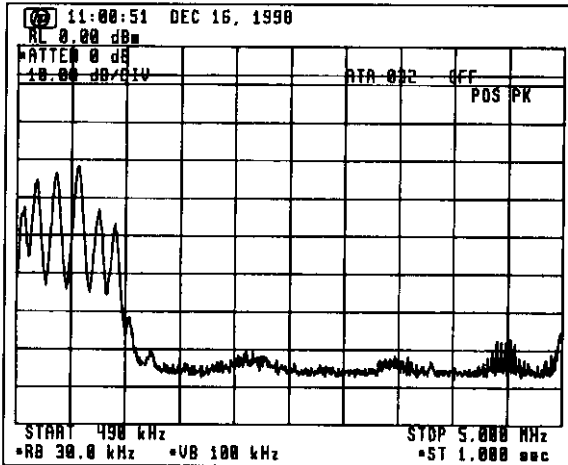

-81 dBm limit line

All components above the limit are from external noise or signals, not from RADAR.

(Band : 5 MHz - 10 MHz, Limit at 2 m = -81 dBm)

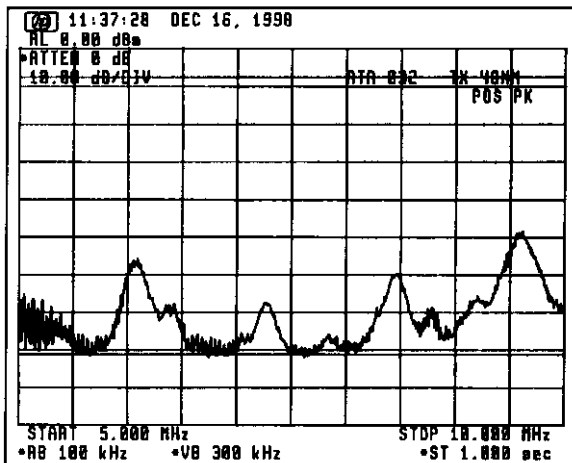
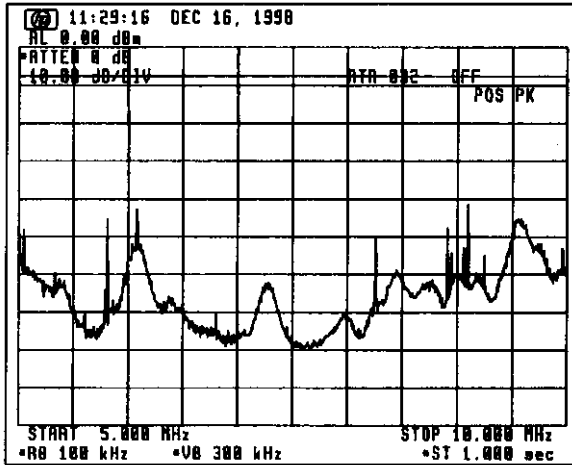

-81 dBm limit line

All components above the limit
are from external noise or
signals, not from RADAR.

(Band : 10 MHz - 30 MHz, Limit at 2 m = -81 dBm)

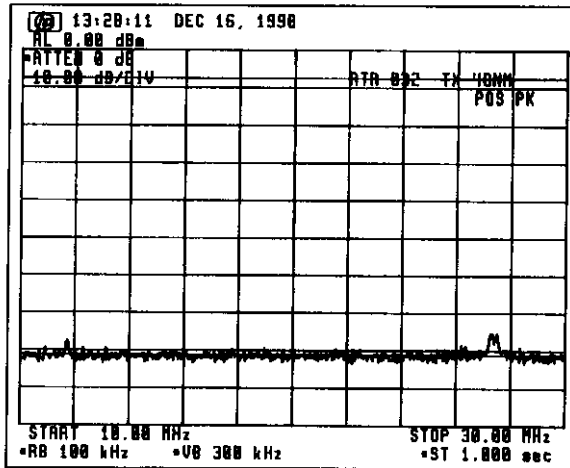
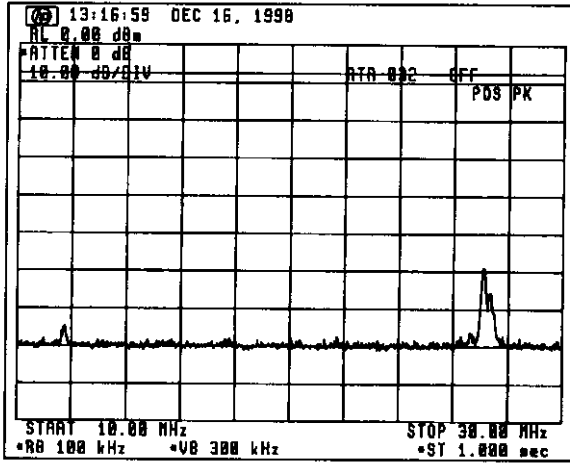

-81 dBm limit line

All components above the limit are from external noise or signals, not from RADAR.

(Band : 30 MHz - 100 MHz, Limit at 2 m = -71 dBm)

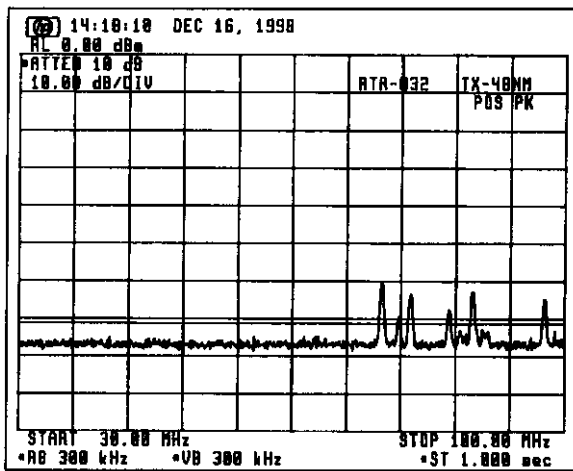
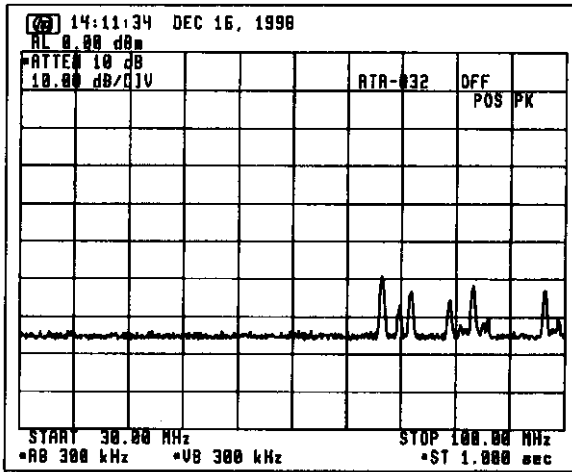

-71 dBm limit line

All components above the limit
are from external noise or
signals, not from RADAR.

(Band : 100 MHz - 300 MHz, Limit at 2 m = -61 dBm)

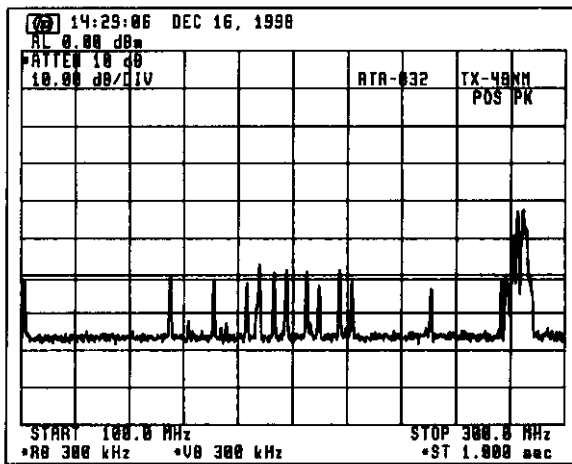
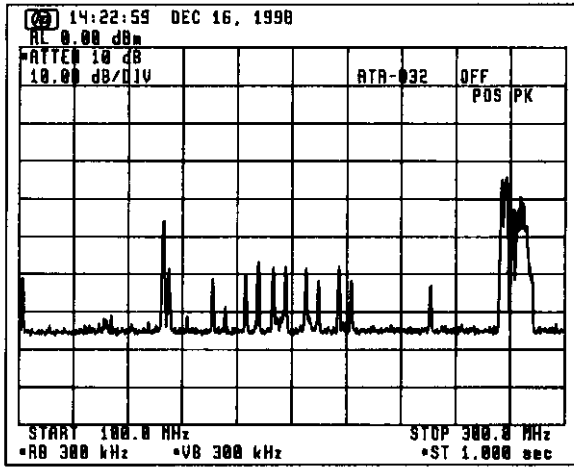

(Band : 300 MHz - 1 GHz, Limit at 2 m = -51 dBm)

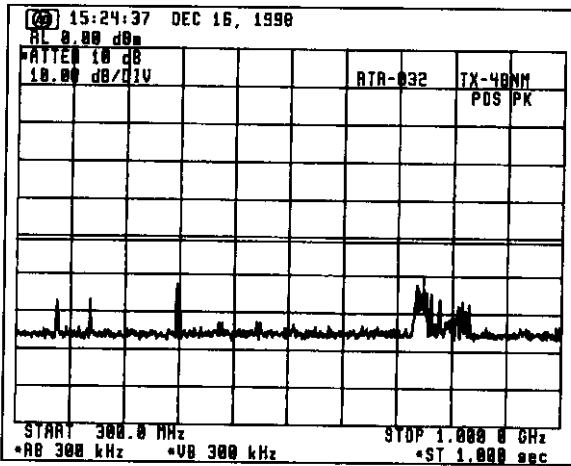
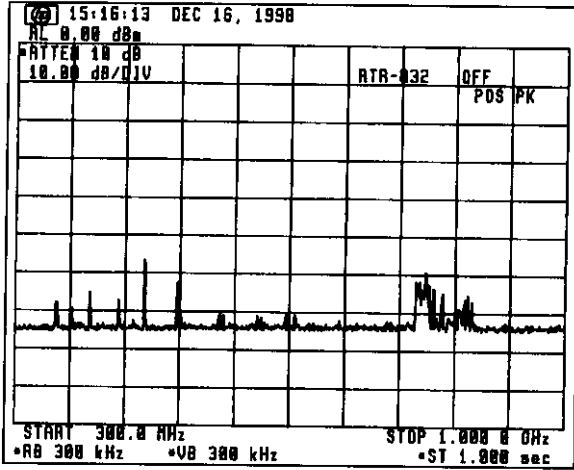

-51 dBm limit line

ATTACHMENT 4 [List of Test/Measuring Equipment] (for S-band radar)**3. RF Power Output**

<u>Model</u>	<u>Type</u>	<u>Serial no.</u>	<u>Mfr.</u>
Spectrum Analyzer	71210C	2927A02847	HP
Oscilloscope	TDS680B	B030202	Tektronix
Directional Coupler	-----	R7231	Shimada
Voltage Divider	P6015	----	Tektronix
Current Transformer	2100	----	Pearson Electronics
Power Meter	436A	2410A19137	HP
Power Sensor	9481A	2349A39603	HP
Frequency Counter	TR5824A	41940036	Advantest
Frequency Meter	X536A	1441A-01864	HP
Crystal Detector	423B	1822A24214	HP
Step Attenuator	8494B	1510A07310	HP
Step Attenuator	8495B	1350A04754	HP
Dummy Load	4D106	R18083	Shimada

4. Modulation Characteristics

<u>Model</u>	<u>Type</u>	<u>Serial no.</u>	<u>Mfr.</u>
Oscilloscope	TDS680B	B030202	Tektronix
Step Attenuator	8494B	1510A07310	HP
Step Attenuator	8495B	1350A04754	HP
Crystal Detector	423B	1822A24214	HP
Directional Coupler	-----	R7231	Shimada
Dummy Load	4D106	R18083	Shimada
Voltage Divider	P6015	----	Tektronix
Spectrum Analyzer	71210C	2927A02847	HP

6. Spurious Emissions at Antenna Terminal

<u>Model</u>	<u>Type</u>	<u>Serial no.</u>	<u>Mfr.</u>
Spectrum Analyzer	71210C	2927A0847	HP
Attenuator (10 dB)	8491B	36122	HP
External Mixer:	11970K	2332A00589	HP
External Mixer:	11970A	2332A01187	HP
Directional Coupler	-----	R7231	Shimada
Dummy Load	4D103	R18083	Shimada
Notch Filter			
Circulator	RC-6584	6254	TDK
Bandpass filter	-----	-----	Furuno
High Pass Filter	-----	-----	Furuno

7. Field Strength of Spurious Radiation

<u>Model</u>	<u>Type</u>	<u>Serial no.</u>	<u>Mfr.</u>
Broadband Rod Antenna	M 95010-1	0496	Advanced Electronics
Biconical Antenna	BIA-25	2650	Electro Metrics
Conical Log-Spiral Antenna	LCA-25	2886	Electro Metrics
Double Ridged Guide Horn Antenna :RGA-180	----	----	EMD
Horn Antenna:	----	----	Toshiba
Spectrum Analyzer:	71210C	2927A0287	HP
External Mixer:	11970K	2332A00589	HP
External Mixer:	11970A	2332A01187	HP
Notch Filter			
Circulator	RC-6584	6254	TDK
Bandpass filter	-----	-----	Furuno

8. Frequency Stability

<u>Model</u>	<u>Type</u>	<u>Serial no.</u>	<u>Mfr.</u>
Power Meter:	436A	2410A19137	HP
Power Sensor:	8481A	2349A39603	HP
Frequency Meter:	X536A	1441A-01864	HP
Directional Coupler:	----	R7231	Shimada
Dummy Load:	4D106	R18083	Shimada
Environmental Chamber:	TBF-3HW5GE2F3013000995		Tabai Espec

9. Suppression of Interference Aboard Ships

<u>Model</u>	<u>Type</u>	<u>Serial no.</u>	<u>Mfr.</u>
Spectrum Analyzer:	71210C	2927A02847	HP
6 m Whip Antenna	14 k - 10 MHz	----	Furuno
4 m Whip Antenna	10 - 30 MHz	----	Furuno
VHF Whip Antenna	30 - 300 MHz	150M-W2UM	Anten
UHF Whip Antenna	300 - 1000 MHz	----	Anten
RF Vector Impedance Meter:	4815A	2048A03354	HP
Spectrum Analyzer	TR4172	30690116	Advantest
Spectrum Analyzer	8566B	2637A03642	HP

