

LABOTECH

TECHNICAL INFORMATION

**TEST REPORT ON THE PERFORMANCE OF
MARINE RADAR**

Trade Mark : FURUNO
Model : FR-1510 MARK-3

Report no. : FLI 12-98-019
Date of issue: Sept. 11, 1998

Furuno Labotech International Co., Ltd.
9-52 Ashihara-cho, Nishinomiya City, Hyogo 662-8580, Japan
Tel. : +81-798-63-1094 Fax. : +81-798-63-1098

This report shall not be reproduced except in full, without the written approval of Furuno Labotech International Co.,



LABOTECH

Furuno Labotech International

Report no. : FLI 12-98-019

All tests were performed in Furuno Labotech International Co., Ltd.
All data herein contained is true and correct to our best knowledge.

All tests were performed by:

name : Katsumi Imamura

function : Test engineer

signature : 

Review and report by:

name : Toshiro Segawa

function : QA manager

signature : 

This report has been verified and approved by:

date : September 11, 1998

name : Sadatomo Kuwahara

function : Manager Engineering Section

signature : 

*** * * * * C O N T E N T S * * * * ***

1 General Information.....	4
2 Identification of Equipment (FCC Rule § 2.925)	9
3 RF Power Output (FCC Rule § 2.985).....	10
4 Modulation Characteristics (FCC Rule § 2.987)	13
5 Occupied Bandwidth (FCC Rule § 2.989)	21
6 Spurious Emissions at Antenna Terminal (FCC Rule § 2.991).....	23
7 Field Strength of Spurious Radiation (FCC Rule § 2.993)	27
8 Frequency Stability (FCC Rule § 2.995).....	31
9 Suppression of Interference Aboard Ships (FCC Rule § 80.217)	34
10 Photographs to Reveal Equipment Construction and Layout (FCC Rule § 2.983)	40
11 Technical Description of Equipment (FCC Rules § 2.983).....	50
11.1 Function of Each Semiconductor or Active Device (FCC RULE § 2.983 (d)(6)).....	50
11.2 Description of the Circuits Employed for Suppression of Spurious Radiation, for Limiting or Shaping the Control Pulse, and for Limiting or Controlling Power	53
12 Operator's Manual Incl. Circuit Diagrams (FCC Rule § 2.983).....	58
Attachment 1 [Test data for 6. Spurious Emissions at Antenna Terminal]	A1
Attachment 2 [Test data for 7. Field Strength of Spurious Radiation]	A2
Attachment 3 [Test data for 9. Suppression of Interference Aboard Ships]	A3
Attachment 4 [List of Test/Measuring Equipment]	A4

1 GENERAL INFORMATION

1.1 General

- (a) **Manufacturer:** Furuno Electric Co., Ltd.
Ashihara-cho 9-52, Nishinomiya-city, 662-8580 Japan
- (b) **Model:** FR-1510 MARK-3
Serial no.: 3366-0003
- (c) **Primary Function:** Search, navigation and anticollision
- (d) **Maximum Range Scale:** 96 nm
- (e) **Discrimination**
Range Discrimination: 35 meters on a range scale of 1.5 nm
Bearing Discrimination: Better than 2.5 ° on a range scale of 1.5 nm
- (e) **Minimum Range:** 35 meters on a range scale of 0.25 nm
- (f) **Frequency Range:** Fixed frequency, X-band
Type of Emission: P0N
- (g) **Power Supply:** 24/32 VDC
100/110/115/220/230 VAC, 50/60 Hz, 1φ

1.2 Transmitter

- (a) **Assignable Frequency for Shipborne Radar:**
Between 9300 and 9500 MHz (FCC Rule § 80.375 (d)-(1))
- (b) **Type of RF Generator**
Magnetron Type: MG5241 or E3566
Peak Output Power: 12 kW nominal
- (c) **Magnetron Ratings**
Center frequency of Magnetron: 9410 MHz
Tolerances
Manufacturing: ± 30 MHz
Pulling: 23 MHz
Tolerance for 20° C temperature variation: 5 MHz
- (d) **Guard Band:**
Guard Band is specified to be equal to 1.5/T MHz, where "T" is the pulselength in microseconds. See para (e). (FCC Rule § 80.209)

(e) Pulse Characteristics:

Pulse Type	Short 1	Short 2	Middle 1	Middle 2	Middle 3	Long
Range Scale (nm)	<u>0.125</u>					
	0.25					
	0.5	<u>0.5</u>				
	0.75 (*)	0.75 (*)	<u>0.75 (*)</u>			
	1.5 (*)	1.5 (*)	1.5 (*)			
	3 (*)	3 (*)	3 (*)	3 (*)		
			6 (*)	6 (*)	6 (*)	6 (*)
			12 (*)	12 (*)	12 (*)	12 (*)
				24 (*)	24 (*)	24 (*)
					48	48
						96
Output pulselength (μs)	0.07	0.15	0.30	0.50	0.70	1.20
P.R.R. (Hz)	3000	3000	1500	1000	1000	600
Duty cycle	2.10E-4	4.50E-4	4.50E-4	5.00E-4	7.00E-4	7.20E-4
Guard Band (MHz)	21.43	10.00	5.00	3.00	2.14	1.25

Note 1:(*) - Two (2) pulse types are selectable for each Range Scale.

2: Tests were carried out for the underlined Range Scales.

1.3 Modulator

(a) FET Type: 2SK1450

1.4 Receiver

(a) Passband

IF Stage:

Pulse Type	Short 1	Short 2	Middle 1	Middle 2	Middle 3	Long
(MHz)	27	27	27	3	3	3

(b) Gain (overall) (dB): Sufficient to cause limiting, approximately 130

(c) Overall Noise Figure (dB): 6 (typical)

(d) Video Output Voltage (V): 0.7 positive across 75 ohms

(e) Features Provided: Sensitivity Time Controls (Anti-clutter Sea),
Fast Time Constant (Anti-clutter Rain)

(f) If receiver is tunable, describe method of adjusting frequency:

Adjustment of tuning voltage of receiver local oscillator (Automatic and manual)

1.5 Display

- (a) Type: 15 (in.) multi-color, 16-level quantization
Rasterscan, non-interlace, 1024 X 768 dots
- (b) Size of Indicator Tube: 15 in. diagonal CRT
effective dia. 180 mm
- (c) Sweep Linearity: 2 % on all ranges

(d) Range Scales:

Range (nm)	Number of Range Rings	Range Ring Interval (nm)
0.125	5	0.025
0.25	5	0.05
0.5	5	0.1
0.75	3	0.25
1.5	6	0.25
3	6	0.5
6	6	1
12	6	2
24	6	4
48	6	8
96	6	16

- (e) Range Ring Accuracy: Better than 1 % of maximum scale in use
or 10 m, whichever is the greater
- (f) Overall Bearing Accuracy from Scanner to Display:
Better than 1°
- (g) Target Plot Facility: Simulated afterglow in low shade
- (h) Heading Indicator: Provided, automatic alignment. Heading Line and Heading
Marker
- (i) True Bearing Indicator: Provided

1.6 Antenna

- (a) Antenna Rotation ON-OFF Switch:
Provided, interlocked with the Power Switch and Transmitter Circuits.
- (b) Reflector: Slotted waveguide array,

Radiator Type	XN12AF	XN20AF
Length (cm)	120	200
Length (ft)	4	6.6

(c) Type of Beam: Vertical fan

(d) Beam Width (between half-Radiator power points)

Radiator Type	XN12AF	XN20AF
Horizontal	1.80°	1.23 °
Vertical	20°	20 °

(e) Polarization: Horizontal

(f) Antenna Gain:

Radiator Type	XN12AF	XN20AF
(dB)	27.9	30.7

(g) Attenuation of Major Side Lobes with respect to main beam:

Radiator Type	XN12AF	XN20AF
Within $\pm 10^\circ$ ($\pm 20^\circ$ for (*))	-24 dB or less (*)	-28 dB or less
Outside $\pm 10^\circ$ ($\pm 20^\circ$ for (*))	-30 dB or less (*)	-32 dB or less

(h) Scanning (rotating or Rotating over 360° continuously oscillating):
clockwise

(i) Antenna Rotation Rate (rpm): 24 rpm (for RSB-0074)
42 rpm (for RSB-0075)

(j) Number of Degrees Scanned: 360°

(k) Sector Scan: Not provided. Sector blanking available.

(l) Type of Transmission System: Contained in scanner unit

(m) Rated Loss of Transmission System per hundred feet::

None. Transmission path is only in the antenna scanner unit.

1.7 Line Power Supply Requirements

(a) Input Voltage: 24/32 VDC
100/110/115/220/230 VAC, 50/60 Hz, 1 ϕ

(b) Power Drain: 200 W
310 VA

1.8 Functional Controls

Range selector	Tune (manual)	EBL offset
INDEX LINE	Anti-clutter auto	Power Switch
A/C Sea control	Gain control	Panel dimmer
Heading line off	Echo stretch	MENU

Guard zone set/Audio alarm off	Range ring brilliance	Noise rejector on/off
Interference rejector	STBY/TX	Trackball (VRM,EBL,GUARD)
VRM on/off	Off-center (SHIFT)	A/C Rain control
Range set	Zoom	EBL on/off
Target trail	Brilliance (screen)	TRU/REL
Navigation on/off	Mark Brilliance	Function #1- #2
Range ring on/off	Text Brilliance	
ARPA function (option)		

1.9 Construction Features

(a) Does equipment embody replacement units with chassis type assembly:

Yes

(b) Are fuse alarms provided: Fuses are provided.

(c) State units which are weatherproof: Scanner Unit (IEC IPX6)

(d) If all units are not housed in a single container, indicate number and give description of individual units:

1 × Display Unit	Type:	RDP-119
1 × Scanner Unit	Type:	RSB-0074 (24 V, 24 rpm)
		RSB-0075 (24 V, 42 rpm)
(Transceiver	Type:	RTR-062 (contained in the Scanner unit))

(e) Approximate Weight of Complete Installation:

Display Unit:	26 kg	
Scanner Unit:	31 kg	(XN12AF-RSB-0074/75)
	34 kg	(XN20AF-RSB-0074/75)

(f) Approximate space required for installation excluding scanner:

Display Unit: 560 mm (W) X 461 mm (H) X 605 mm (D)

1.10 Operational Features

(a) Is positive means provided to indicate whether or not the overall operation of the equipment is such that it may be relied upon to provide effective operation in accordance with its primary function:

Magnetron/Xtal checker

(b) Is the equipment for continuous operation:

Yes

(c) Is provision made for operation with shore based radar beacons (RACONS):

Yes (RACONS and SART)

2 IDENTIFICATION OF EQUIPMENT (FCC Rule § 2.925)

The following nameplates are permanently fixed on the corresponding equipment units.

FCC ID: ADB9ZWFR1510M3

Material of nameplate: Aluminum, 0.5 mm thick

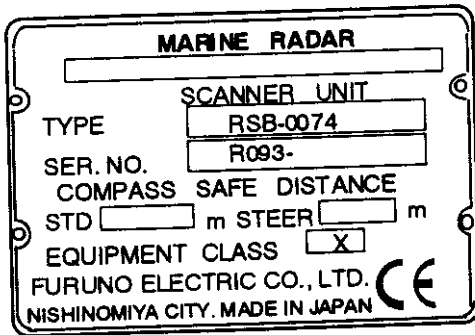

Fig. 2.1
Nameplate for
Scanner Unit
(RSB-0074)

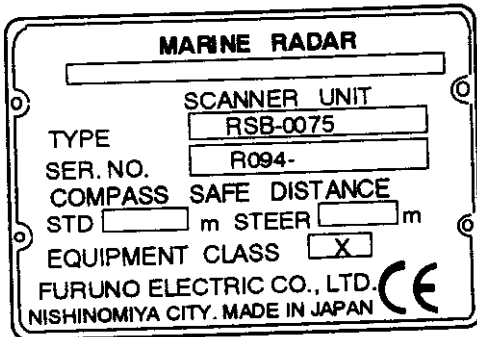

Fig. 2.2
Nameplate for
Scanner Unit
(RSB-0075)

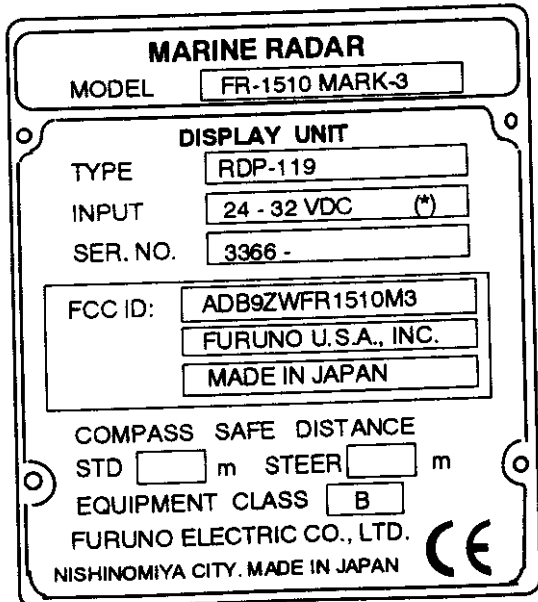

Fig. 2.3
Nameplate for
Display Unit
(RDP-119)

Note: (*)
(1) 100 - 115 VAC, or
(2) 220 - 230 VAC
for AC Power Supply.

3 RF POWER OUTPUT (FCC Rule §2.985)**3.1 Microwave characteristics**

The peak voltage was determined using the divider having a ratio of 1000 to 1 and the oscilloscope. Current pulse was viewed across the wideband current transformer with output voltage per ampere 1.00.

Nominal values

Pulse Type	Short 1	Short 2	Middle 1	Middle 2	Middle 3	Long
Range scale (nm)	0.125	0.5	0.75	6	12	96
Pulselength (μ s)	0.07	0.15	0.30	0.50	0.70	1.20
PRR (Hz)	3000	3000	1500	1000	1000	600
Duty cycle	2.10E-4	4.50E-4	4.50E-4	5.00E-4	7.00E-4	7.20E-4
Guard band (MHz)	21.43	10.00	5.00	3.00	2.14	1.25

Measured values

Magnetron input pulse voltage was measured at its cathode using the oscilloscope and divider with ratio 1000 to 1.

Pulse Type	Short 1	Short 2	Middle 1	Middle 2	Middle 3	Long
Directional coupler attenuation (dB)	40.54	40.54	40.54	40.54	40.54	40.54
Magnetron input voltage (kV)	6.20	6.20	6.20	6.00	6.00	6.00
Pulselength (μ s) (50 % amplitude)	0.294	0.480	0.892	0.960	0.896	1.332
Rise time (μ s) (10-90 % amplitude)	0.072	0.080	0.080	0.080	0.080	0.080
Decay time (μ s) (90-10 % amplitude)	0.230	1.228	1.104	0.932	0.684	0.296

Magnetron input pulse current

Magnetron input pulse current was observed across the wideband current transformer with output voltage per ampere 1.00.

Pulse Type	Short 1	Short 2	Middle 1	Middle 2	Middle 3	Long
Magnetron input current (A)	3.6	3.6	4.5	5.9	5.9	5.9

Pulse Type	Short 1	Short 2	Middle 1	Middle 2	Middle 3	Long
Pulselength (μ s) (50 % amplitude)	0.106	0.155	0.294	0.458	0.678	1.128
Rise time (μ s) (10-90 % amplitude)	0.078	0.080	0.150	0.252	0.276	0.260
Decay time (μ s) (90-10 % amplitude)	0.095	0.110	0.222	0.240	0.288	0.748

RF envelope of the magnetron output pulse

The RF envelope of the magnetron output pulse was measured using a diode and the oscilloscope with the following results:

Pulse Type	Short 1	Short 2	Middle 1	Middle 2	Middle 3	Long
Pulselength (μ s) (-3 dB points)	0.115	0.157	0.309	0.474	0.686	1.132
Rise time (μ s) (10-90 % amplitude)	0.020	0.020	0.150	0.150	0.180	0.180
Decay time (μ s) (90-10 % amplitude)	0.095	0.114	0.236	0.222	0.156	0.156

Estimated efficiency

The estimated efficiency of the RF generator (magnetron) was determined by the following measurements and calculation. Power output from magnetron was measured using the directional coupler, power meter and the oscilloscope.

Pulse Type	Short 1	Short 2	Middle 1	Middle 2	Middle 3	Long
Range scale (nm)	0.125	0.5	0.75	6	12	96
PRR (Hz)	3089.1	2876.1	1544.6	1004.9	1004.9	600.0
Duty cycle	3.55E-4	4.52E-4	4.77E-4	4.76E-4	6.89E-4	6.79E-4
Magnetron input, av. (W)	7.93	10.08	13.32	16.86	24.40	24.04
Magnetron input, peak (kW)	22.32	22.32	27.90	35.40	35.40	35.40
Power meter reading (mW)	0.260	0.319	0.406	0.471	0.695	0.663
Magnetron output, av. (W)	2.944	3.612	4.598	5.334	7.870	7.508
Spurious response limits (dB)	47.7	48.6	49.6	50.3	52.0	51.8
Magnetron Output, peak (kW):	8.29	8.00	9.63	11.20	11.42	11.05
Magnetron efficiency (%):	37.1	35.8	34.5	31.6	32.3	31.2

Peak Power Input to RF Generator : 28.7 kW

Estimated Efficiency of RF Generator : 34.3 %

4 MODULATION CHARACTERISTICS (FCC Rule §2.987)

4.1 FET Trigger Pulse

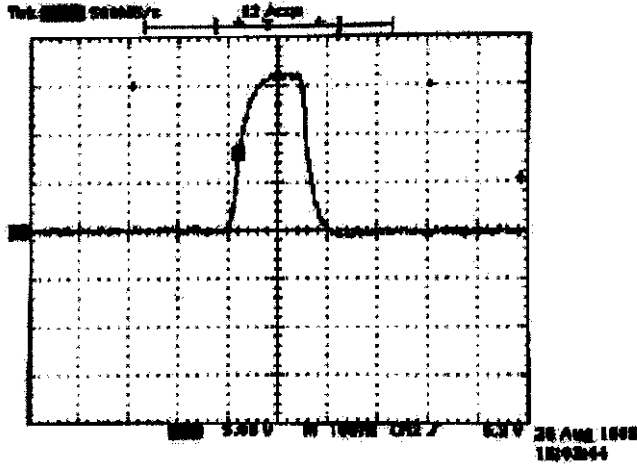

Fig. 4.1.1

(Typical wave form of Trigger Pulse)
Short 1 Pulse (0.125 nm Range)

Scale: 5 V/div.
100 ns/div.

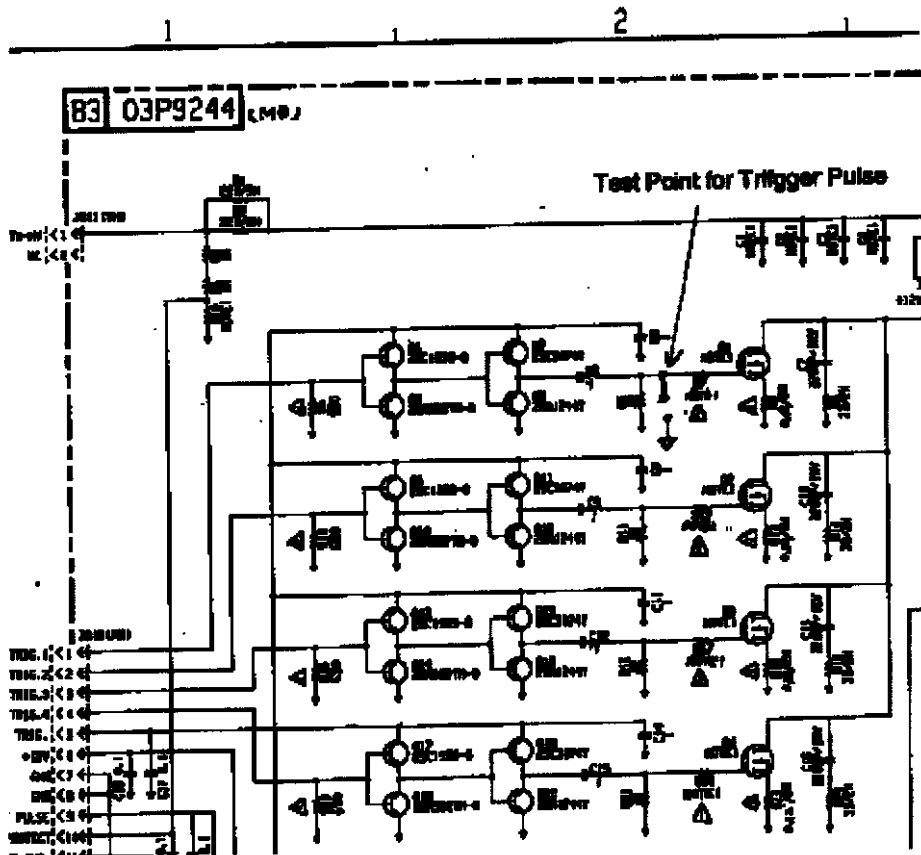

Fig. 4.1.2 Test Point for Trigger Pulse

4.2 Trigger Pulse at Magnetron Cathode

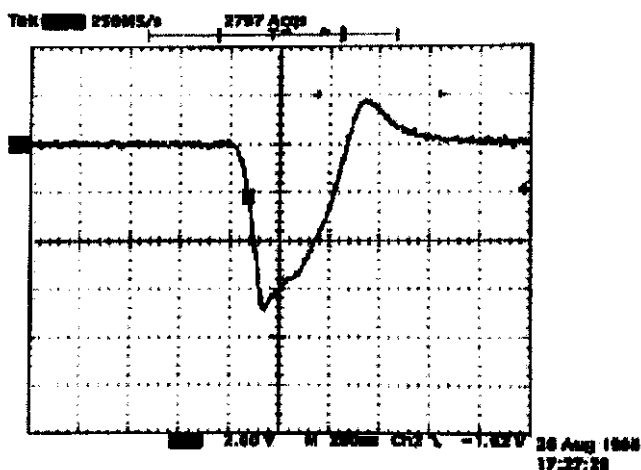

Fig. 4.2.1

Short 1 Pulse (0.125 nm Range)

Scale: 2 kV/div. 200 ns/div.

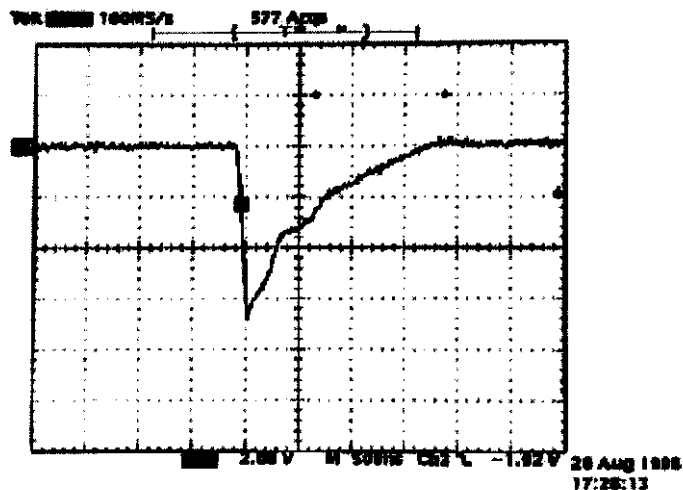

Fig. 4.2.2

Short 2 Pulse (0.5 nm Range)

Scale: 2 kV/div. 500 ns/div.

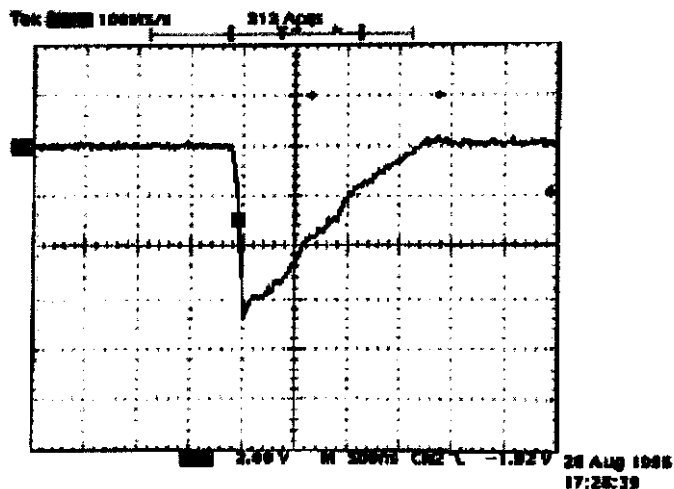

Fig. 4.2.3

Middle 1 Pulse (0.75 nm Range)

Scale: 2 kV/div. 500 ns/div.

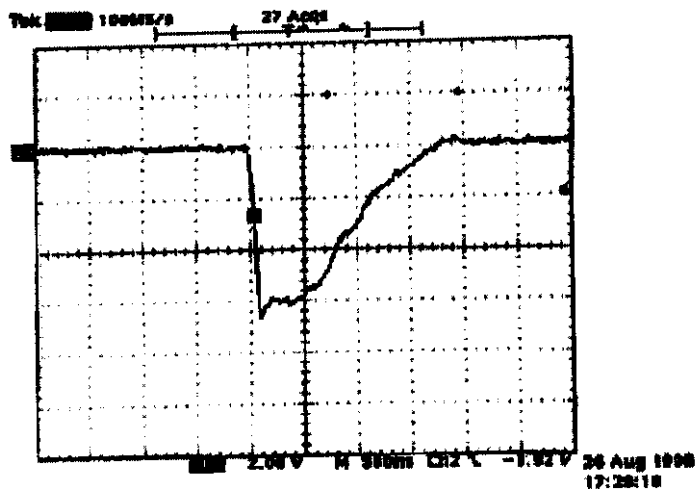

Fig. 4.2.4

Middle 2 Pulse (6 nm Range)

Scale: 2 kV/div. 500 ns/div.

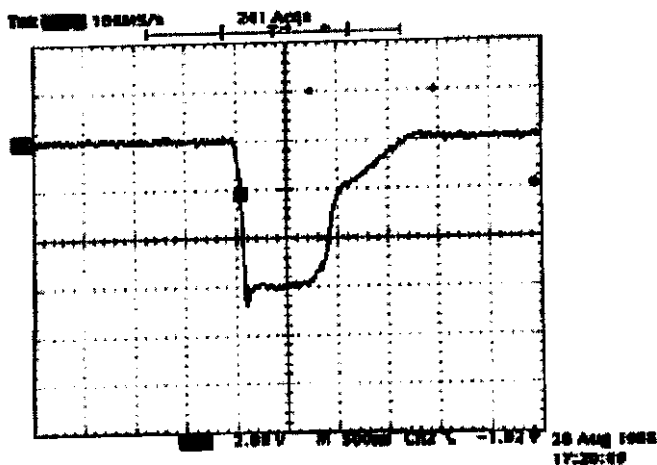

Fig. 4.2.5

Middle 3 Pulse (12 nm Range)

Scale: 2 kV/div. 500 ns/div.

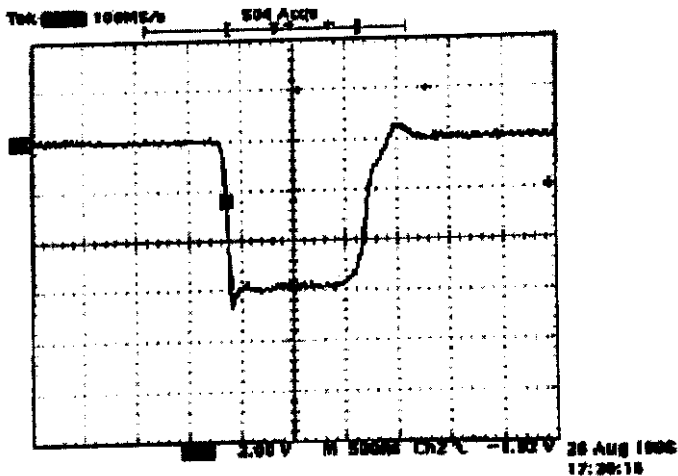

Fig. 4.2.6

Long Pulse (96 nm Range)

Scale: 2 kV/div. 500 ns/div.

4.3 Magnetron Output (detected):

4.3.1 Setup for Measurement:

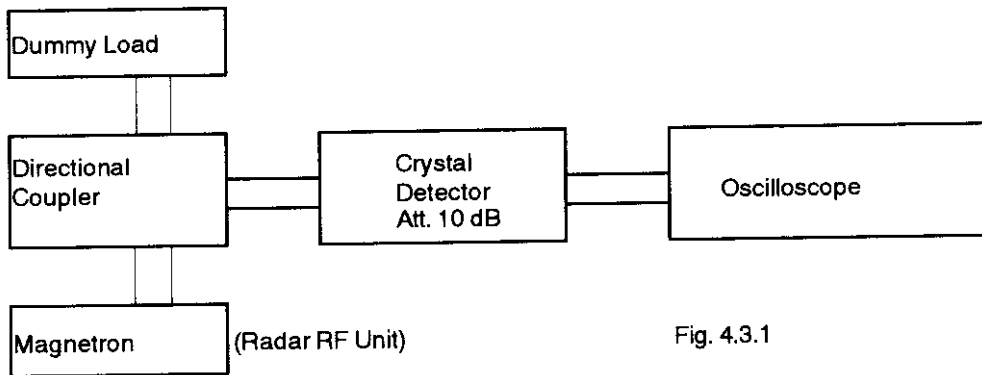

Fig. 4.3.1

4.3.2 Measuring Equipment List:

See ATTACHMENT 4 [LIST OF TEST/MEASURING EQUIPMENT].

4.3.3 Measured Data:

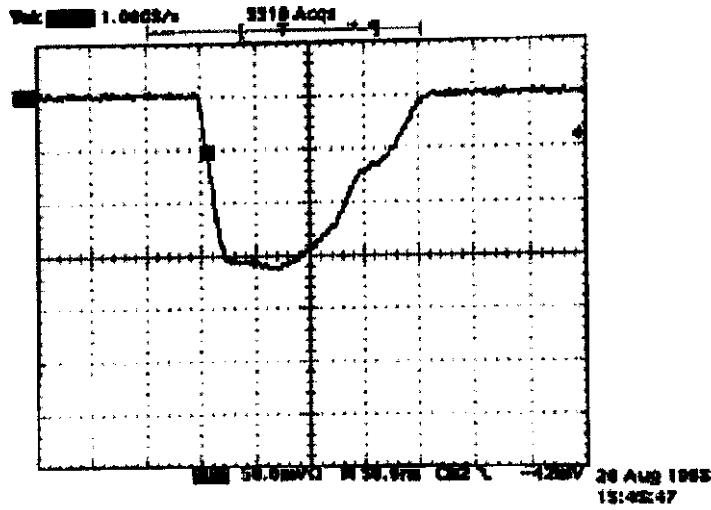

Fig. 4.3.2

Short 1 Pulse (0.125 nm Range)

Scale: 50 mV/div. 50 ns/div.

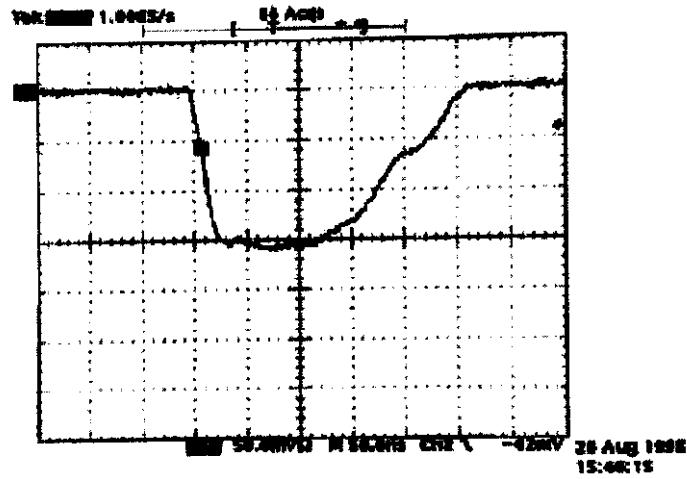

Fig. 4.3.3

Short 2 Pulse (0.5 nm Range)

Scale: 50 mV/div. 50 ns/div.

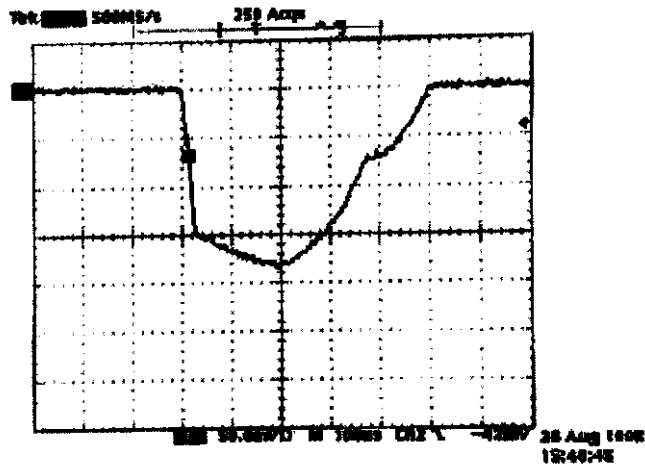

Fig. 4.3.4

Middle 1 Pulse (0.75 nm Range)

Scale: 50 mV/div. 100 ns/div.

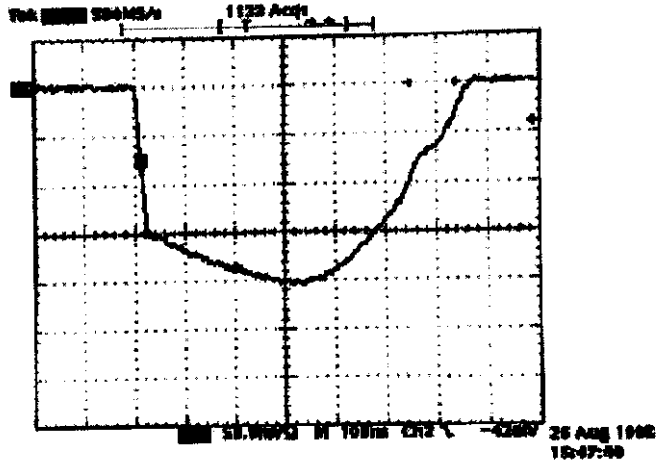

Fig. 4.3.5

Middle 2 Pulse (6 nm Range)

Scale: 50 mV/div. 100 ns/div.

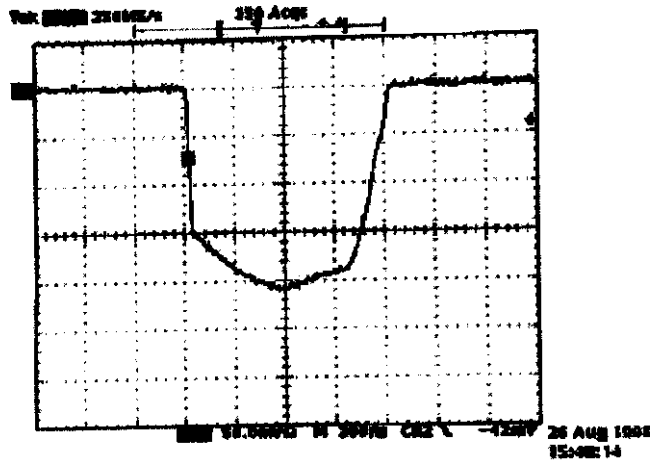

Fig. 4.3.6

Middle 3 Pulse (12 nm Range)

Scale: 50 mV/div. 200 ns/div.

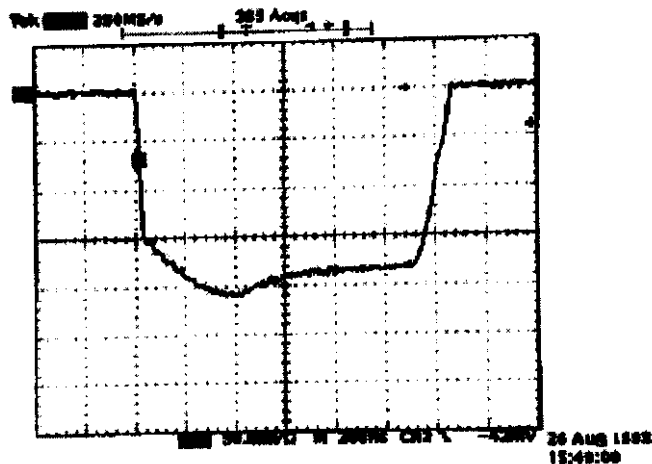

Fig. 4.3.7

Long Pulse (96 nm Range)

Scale: 50 mV/div. 200 ns/div.

4.4 Radar Pulse Spectrum:

Measured by the spectrum analyzer.

(Test Equipment Setup and Measuring Equipment List are same as Clause 6.1 and 6.2.)

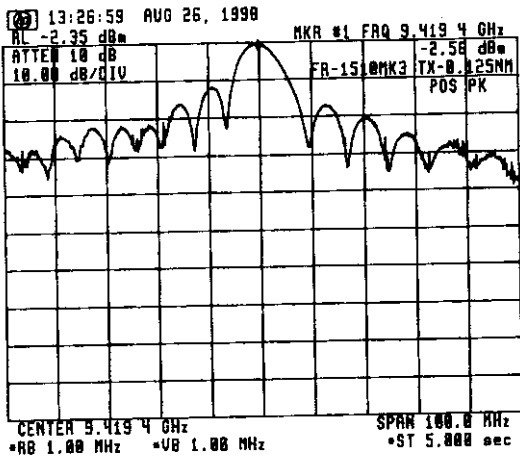

Fig. 4.4.1 For Short 1 Pulse (0.125 nm Range)

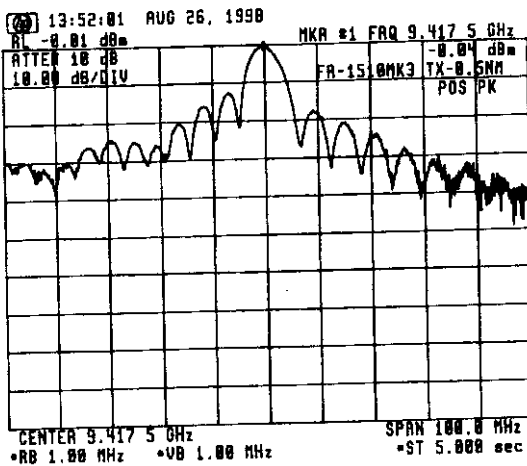

Fig. 4.4.2 For Short 2 Pulse (0.5 nm Range)

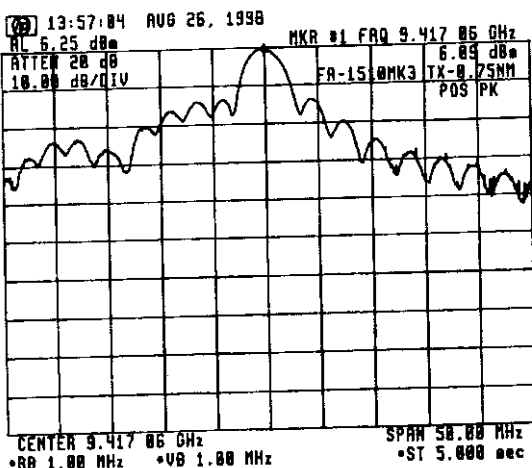

Fig. 4.4.3 For Middle 1 Pulse (0.75 nm Range)

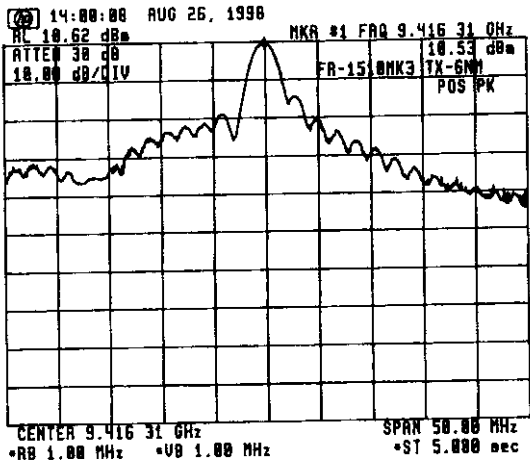

Fig. 4.4.4 For Middle 2 Pulse (6 nm Range)

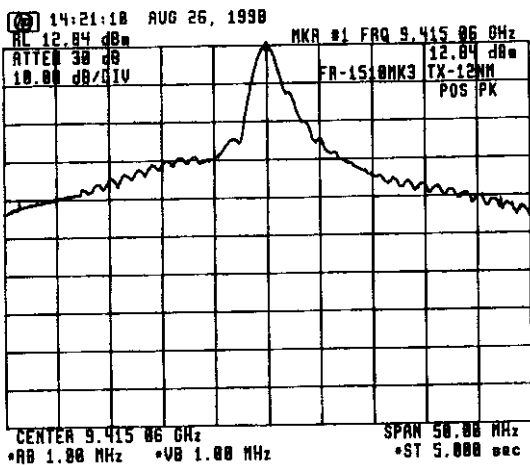

Fig. 4.4.5 For Middle 3 Pulse (12 nm Range)

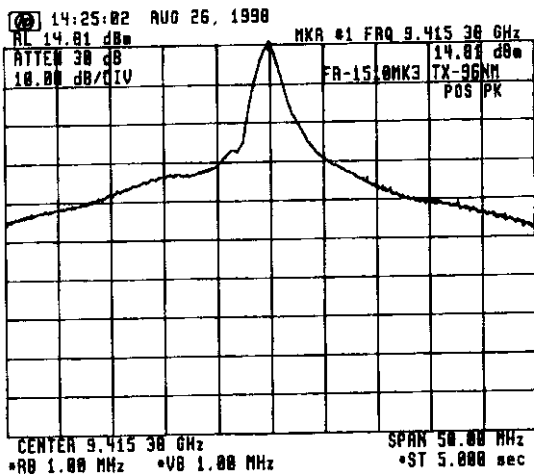

Fig. 4.4.6 For Long Pulse (96 nm Range)

5 OCCUPIED BANDWIDTH (FCC Rule § 2.989)

5.1 Measuring Method

FCC rule 47 CFR 2.989 requires measurements of the occupied bandwidth which is defined in the same section as "the frequency bandwidth such that, below its lower and above its upper frequency limits, the mean powers radiated are each equal to 0.5 percent of the total mean power radiated by a given emission."

To obtain the occupied bandwidth of the radar transmitter, a special program (program list shown below) was loaded to the Hewlett-Packard spectrum analyzer and run by entering the HP-provided POWER BANDWIDTH calculation command [PWRBW].

The result was automatically displayed on the screen on the spectrum analyzer as:

POWER_BW=----- MHz

```
10 ! HP_71000 DOWNLOAD PROGRAM
20 ASSIGN @Sa TO 718
30 CLEAR @Sa
40 CALL M_ain(@Sa)
50 LOCAL @Sa
60 END
70 !
80 SUB M_ain(@Sa)
90 M_ain: !
100 CALL Pwr_bw(@Sa)
110 CALL Limit_line(@Sa)
120 !
130 OUTPUT @Sa;"VARDEF K_ey,0;";
140 !
150 OUTPUT @Sa;"FUNCDEF D_LP,^";
160 OUTPUT @Sa;"MOV K_ey,0;";
170 !
180 Main_menu: !
190 OUTPUT @Sa;"REPEAT;";
200 OUTPUT @Sa;"READMENU K_ey, ";
210 ! location: %Top----Bottom-%
220 OUTPUT @Sa;"1,%Limit line %, ";
230 OUTPUT @Sa;"2,%Power bw %, ";
240 OUTPUT @Sa;"14,% Exit%;";
250 !
260 OUTPUT @Sa;"IF K_ey,EQ,1;THEN;LIMIT_LINE;";
270 OUTPUT @Sa;"ELSIF K_ey,EQ,2;THEN;PWR_BW;";
280 OUTPUT @Sa;"ELSIF K_ey,EQ,14;THEN;ABORT;";
290 OUTPUT @Sa;"ENDIF;";
300 OUTPUT @Sa;"UNTIL K_ey,EQ,14;";
310 OUTPUT @Sa;"IP;TS;";
320 OUTPUT @Sa;"ADORT;";
330 OUTPUT @Sa;"^";
340 !
350 Define_keydef: !
360 OUTPUT @Sa;"KEYDEF 7,D_LP, %DLP TEST%;";
370 !
380 OUTPUT @Sa;"FUNCDEF D,^";
390 OUTPUT @Sa;"KEYPST;";
400 OUTPUT @Sa;"^";
410 !
420 SUBEND
430 !
440 SUB Limit_line(@Sa)
450 Limit_line: !
460 OUTPUT @Sa;"CLRDSP;";
470 OUTPUT @Sa;"FUNCDEF LIMIT_LINE,^";
480 OUTPUT @Sa;"PU;PA 0,654;";
490 OUTPUT @Sa;"LINET 1;";
500 OUTPUT @Sa;"PD;PA 100,654;";
510 OUTPUT @Sa;"PU;PA 201,654;";
520 OUTPUT @Sa;"PD;PA 300,654;";
530 OUTPUT @Sa;"PU;PA 105,630;";
540 OUTPUT @Sa;"TEXT @-35dB@;";
550 OUTPUT @Sa;"PU;PA 205,720;";
560 OUTPUT @Sa;"TEXT @-25dB@;";
570 OUTPUT @Sa;"PU;PA 301,743;";
580 OUTPUT @Sa;"LINET 1;";
590 OUTPUT @Sa;"PD;PA 400,743;";
600 OUTPUT @Sa;"PU;PA 601,743;";
610 OUTPUT @Sa;"LINET 1;";
620 OUTPUT @Sa;"PD;PA 700,743;";
630 OUTPUT @Sa;"PU;PA 701,654;";
640 OUTPUT @Sa;"LINET 1;";
650 OUTPUT @Sa;"PD;PA 1000,654;HD;";
660 OUTPUT @Sa;"^";
670 SUBEND
680 SUB Pwr_bw(@Sa)
690 Pwr_bw: !
700 ! Calculating Power band width
710 OUTPUT @Sa;"VARDEF P_bw,0;";
720 OUTPUT @Sa;"FUNCDEF PWR_BW,^";
730 OUTPUT @Sa;"CLRW TRA;";
740 OUTPUT @Sa;"CLRDSP;";
750 OUTPUT @Sa;"SNGLS;";
760 OUTPUT @Sa;"MXMH TRA;TS;TS;TS;";
770 OUTPUT @Sa;"MOV P_bw,PWRBW TRA,99,0;";
780 OUTPUT @Sa;"DIV P_bw,P_bw,1000000;";
790 OUTPUT @Sa;"PU;PA 10,800;HD;";
800 OUTPUT @Sa;"TEXT @POWER_BW = @;";
810 OUTPUT @Sa;"DSPLY P_bw,8,3;";
820 OUTPUT @Sa;"TEXT @ MHz @;";
830 OUTPUT @Sa;"^";
840 SUBEND
```

Fig. 5.1

Program for Calculation of Occupied Bandwidth

6 SPURIOUS EMISSIONS AT ANTENNA TERMINAL (FCC Rule § 2.991)

6.1 Test Equipment Setup:

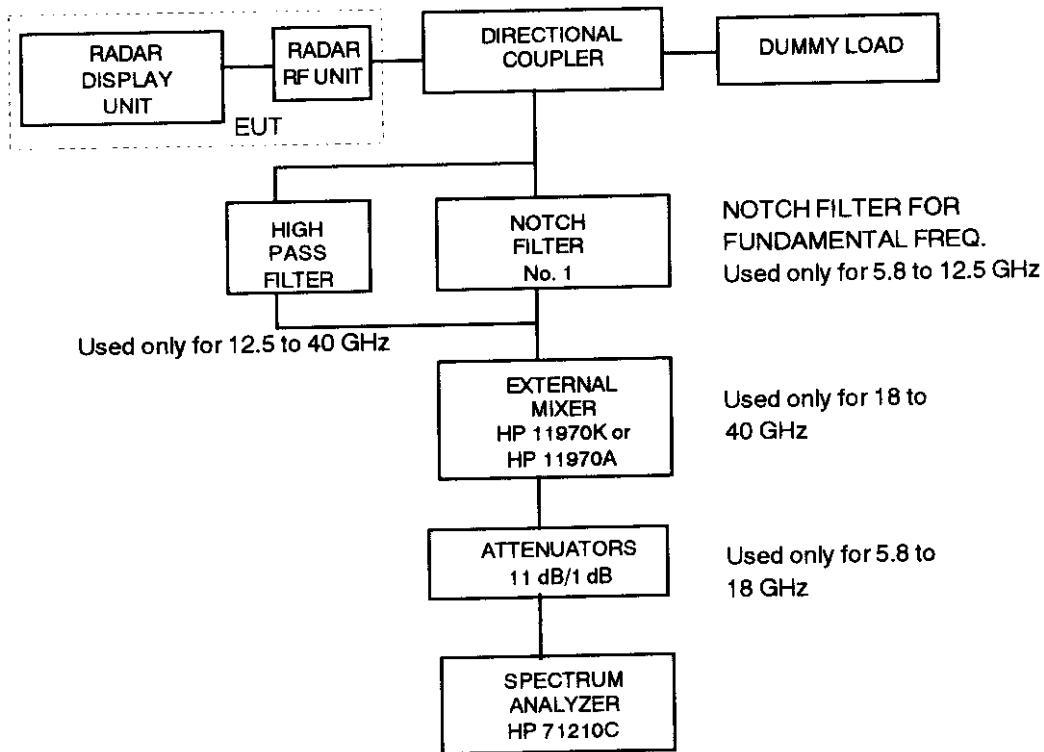

Fig. 6.1

6.2 Measuring Equipment List:

See ATTACHMENT 4 [LIST OF TEST/MEASURING EQUIPMENT].

- Note :
- (1) The characteristics of Notch Filter (No. 1) are described in Fig. 6.2 to Fig. 6.5.
 - (2) The characteristic of High Pass Filter (No. 2) is described in Fig. 6.6.

6.3 Test Conditions:

Radar Range Settings: 0.125 nm (Short 1)/0.5 nm (Short 2)/0.75 nm (Middle 1)/
6 nm (Middle 2)/12 nm (Middle 3)/96 nm (Long)

6.4 Emission Limits:

- (a) Frequency Range (FCC Rule § 2.997) : 10 kHz - 40 GHz
- (b) Emission Limits (FCC Rule § 80.211) :

Frequency removed from the assigned frequency	Frequency (Hz)	Emission attenuation (mean power ,dB)
50 - 100 % (of the authorized bandwidth)	9310 - 9360 M 9460 - 9510 M	At least 25
100 - 250 %	9160 - 9310 M 9510 - 9660 M	At least 35
more than 250 %	10 k - 9160 M 9660 - 40,000 M	At least $43 + 10 \log 10$ (mean power in watts)

- Note : (1) Assigned frequency (center frequency) = 9410 MHz
(2) Authorized bandwidth = 100 MHz

6.5 Test Results:

As shown in ATTACHMENT 1 , the spurious emissions at antenna terminal of EUT are found lower than the specified limits.

(Note: Spurious emissions for 10 kHz to 5 GHz are not found due to the antenna terminal structure. (wave guide tube)).

Characteristic of Filter No. 1 (for X-band)

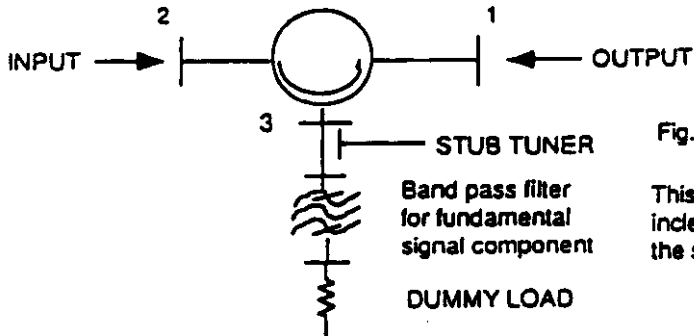

Fig. 6.2 Setup of Notch Filter No.1

This notch filter is used to increase the dynamic range of the spectrum analyzer

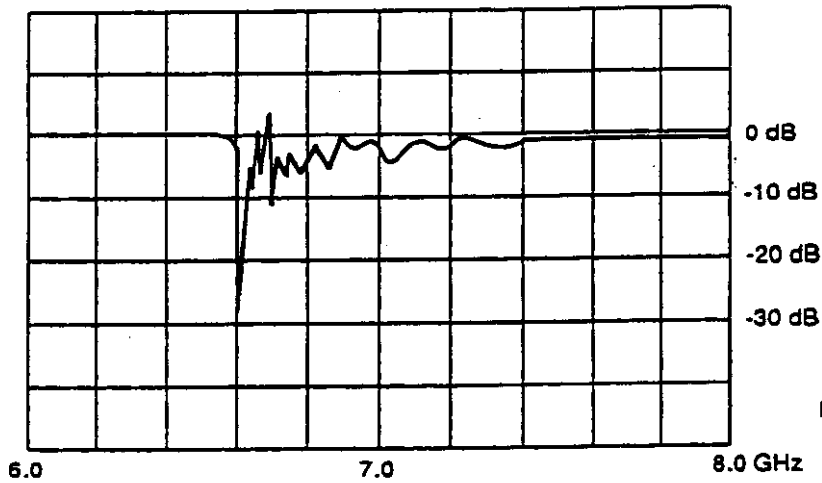

Fig. 6.3

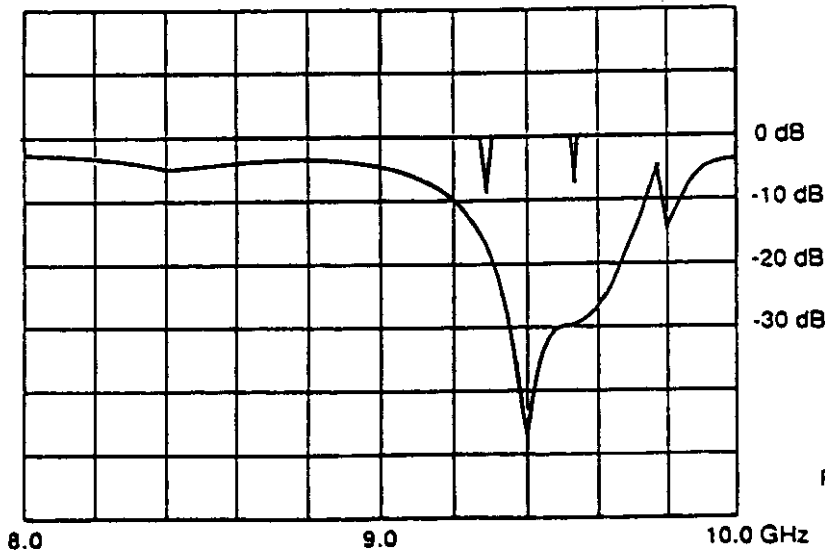

Fig. 6.4

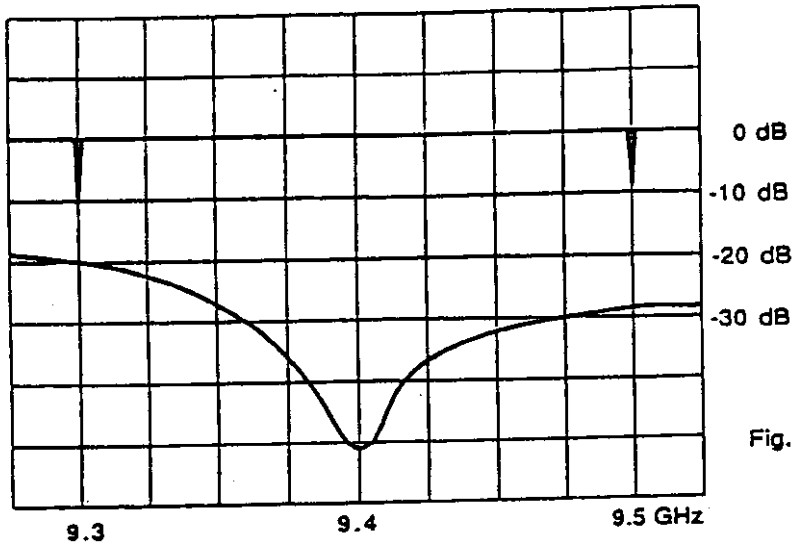
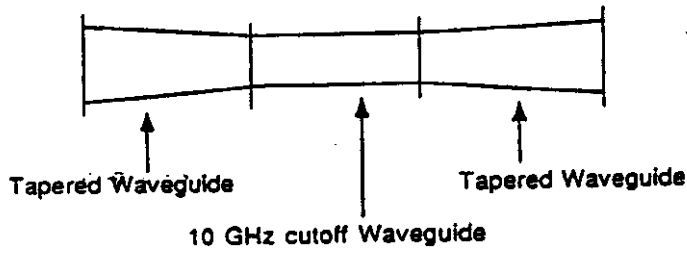

Fig. 6.5

Characteristic of Filter No. 2 (for X-band)



This filter is used to filter out the high level fundamental signal to avoid damage to the analyzer.

High Pass Filter Construction

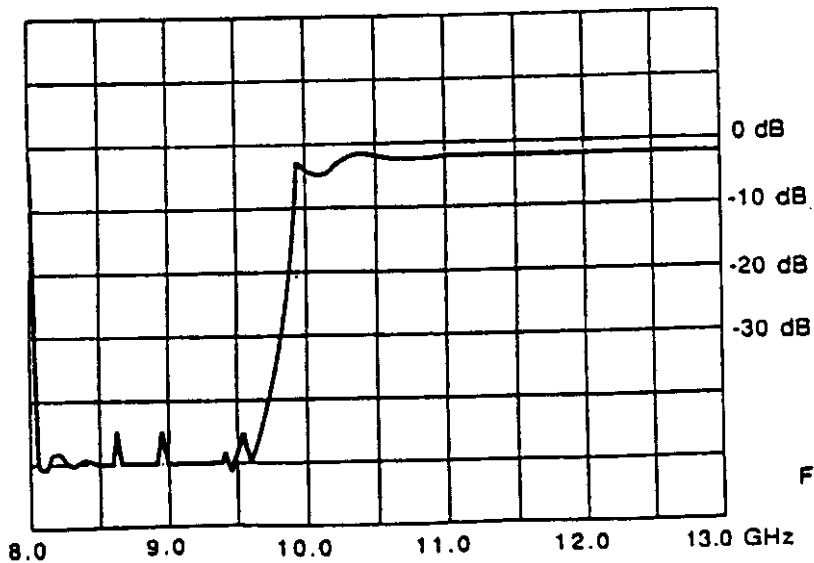

Fig. 6.6

7 FIELD STRENGTH OF SPURIOUS RADIATION (FCC Rule § 2.993)

7.1 **Test Site:** Rooftop of 6-story building,
FURUNO ELECTRIC CO., LTD.
Ashihara-cho 9-52, Nishinomiya-city, 662-8580 Japan

7.2 **Date:** Sept, 1998

7.3 **Distance between the radar set and measuring antenna:** 10 m

7.4 **Radar Range settings:** 0.125 nm (Short 1)/0.5 nm (Short 2)/0.75 nm (Middle 1)/
6 nm (Middle 2)/12 nm (Middle 3)/96 nm (Long)

7.5 **Measuring Equipment List:**
See ATTACHMENT 4 [LIST OF TEST/MEASURING EQUIPMENT].

7.6 **Test settings:**
See Fig. 7.1 - Fig. 7.5.

7.7 **Field Strength Limits:**
(a) Frequency Range (FCC Rule § 2.997) : 10 kHz - 40 GHz
(b) Emission Limits (FCC Rule § 80.211) :

Frequency removed from the assigned frequency	Frequency (Hz)	Emission attenuation (mean power ,dB)
50 - 100 % (of the authorized bandwidth)	9310 - 9360 M	At least 25
	9460 - 9510 M	
100 - 250 %	9160 - 9310 M	At least 35
	9510 - 9660 M	
more than 250 %	10 k - 9160 M 9660 - 40,000 M	At least 43 + 10 log 10 (mean power in watts)

Note : (1) Assigned frequency (center frequency) = 9410 MHz
(2) Authorized bandwidth = 100 MHz

7.8 **Test Results:**
As shown in ATTACHMENT 2 , the field strengths of spurious radiation generated by EUT are found lower than the specified limits.



8 FREQUENCY STABILITY (FCC Rule § 2.995)

8.1 Setup for Measurement

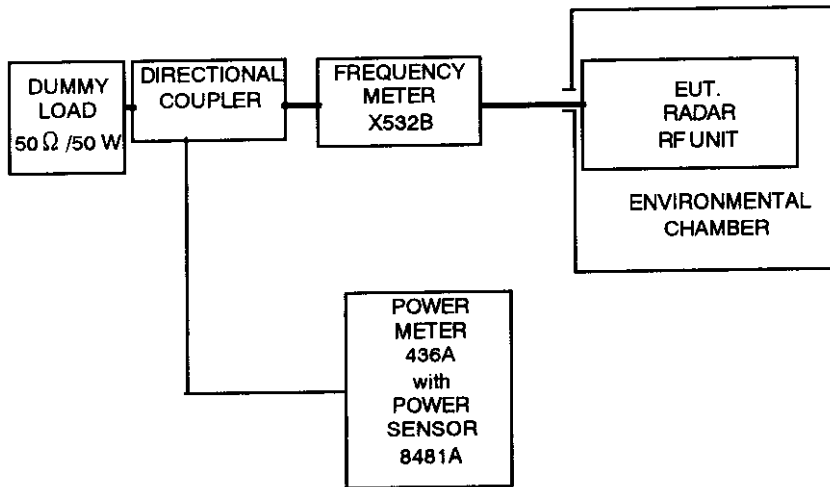

Fig. 8.1

8.2 Test Conditions:

- 1) Radar Range settings : 0.125 nm (Short 1)/0.5 nm (Short 2)/0.75 nm (Middle 1)/
6 nm (Middle 2)/12 nm (Middle 3)/96 nm (Long)
- 2) Ambient Temperature settings: - 20 to + 50 °C (10 °C step)
- 3) Power Supply Voltage settings: 85 /115 % of nominal voltage (20.4 to 27.6 VDC)

8.3 Measuring Equipment List:

See ATTACHMENT 4 [LIST OF TEST/MEASURING EQUIPMENT].

8.4 Frequency Tolerance Limits:

"The frequency at which maximum emission occurs must be within the authorized bandwidth and must not be closer than $1.5/T$ MHz to the upper and lower limits of the authorized band width, where "T" is the pulse duration in microseconds. "
(FCC Rule § 80.209)

- 1) Center frequency (f_0): 9410 MHz
- 2) Authorized bandwidth ($f(\text{AUBW})$): 100 MHz
"Upper limit frequency of the authorized band", $f(\text{UAUBW}) = f_0 + f(\text{AUBW})/2 = 9460$ MHz
"Lower limit frequency of the authorized band", $f(\text{LAUBW}) = f_0 - f(\text{AUBW})/2 = 9360$ MHz
- 3) Assignable frequency bandwidth : 200 MHz (between 9300 MHz and 9500 MHz)
(FCC Rule § 80.375 (d)-(1))

"Upper limit frequency of the assignable band", $f(\text{UASB}) = 9500$ MHz

"Lower limit frequency of the assignable band", $f(\text{LASB}) = 9300$ MHz

- 4) Guard Band ($f(1.5/T)$) :

Pulse Type	Short 1	Short 2	Middle 1	Middle 2	Middle 3	Long
Range Scale (nm)	0.125	0.5	0.75	6	12	96
Pulselength (μ sec)	0.07	0.15	0.30	0.50	0.70	1.20
Guard Band $f(1.5/T)$ (MHz)	21.43	10.00	5.00	3.00	2.14	1.25

8.5 Test Results:

Shown on Fig. 8.2.

(1) "Upper Tolerance Frequency measured (at -20 °C)", $f(\text{U}) = 9425.9$ MHz

(2) "Lower Tolerance Frequency measured (at $+50$ °C)", $f(\text{L}) = 9413.1$ MHz

(3)-(a)

$f(\text{U}) + \text{max. } f(1.5/T) = 9447.3$ MHz $< f(\text{UAUBW}) = 9460$ MHz $< f(\text{UASB}) = 9500$ MHz

(b)

$f(\text{L}) - \text{max. } f(1.5/T) = 9391.7$ MHz $> f(\text{LAUBW}) = 9360$ MHz $> f(\text{LASB}) = 9300$ MHz

So, both are found within the specified limits.

FREQUENCY STABILITY WITH VARIATION OF PRIMARY SUPPLY VOLTAGE:

The built-in voltage regulator allows no frequency variation against variations of $\pm 15\%$ of nominal power supply voltage (20.4 to 27.6 VDC for nominal 24 VDC).

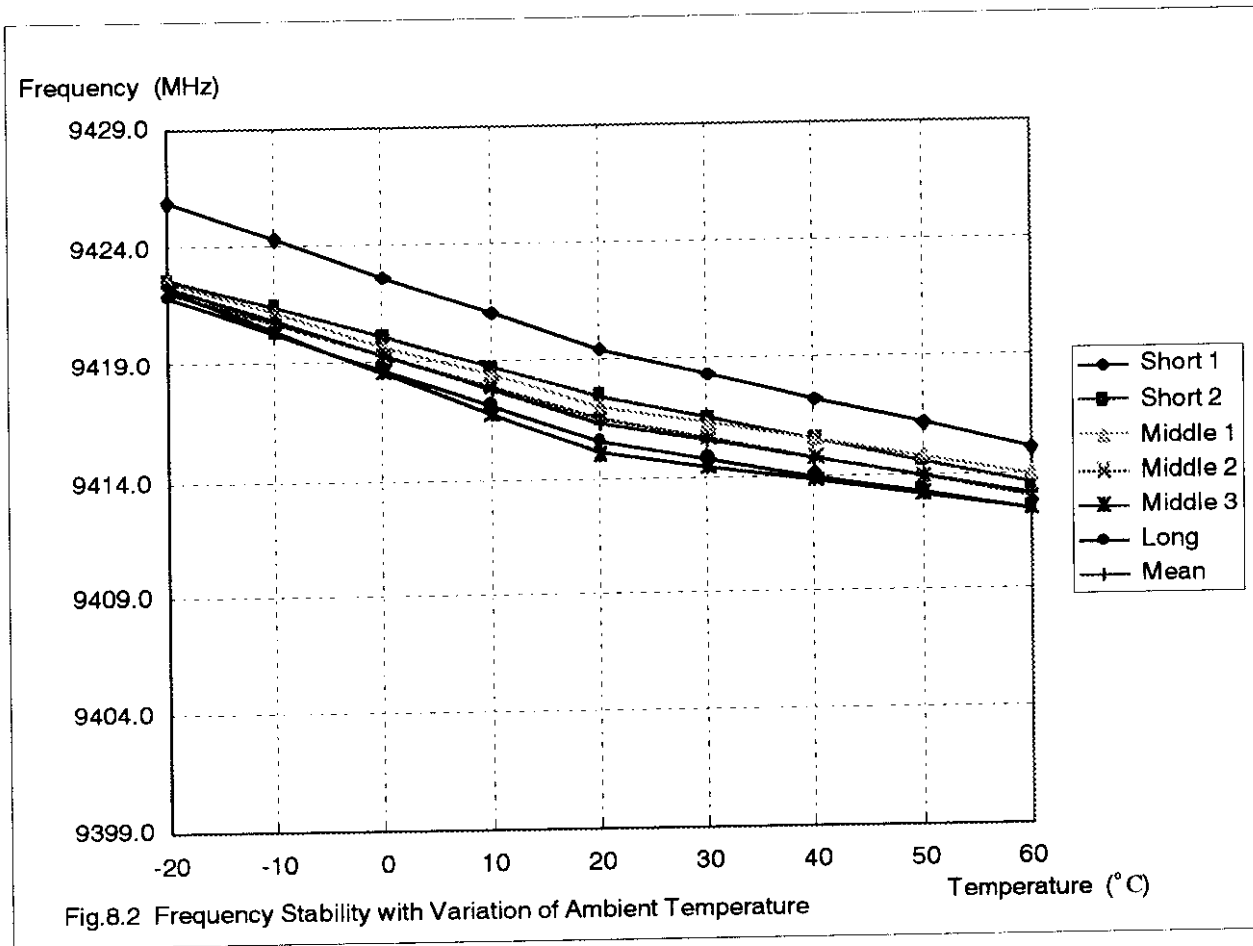

9 SUPPRESSION OF INTERFERENCE ABOARD SHIPS

(FCC Rule § 80.217)

9.1 Measuring Antenna Characteristics at Representative Frequencies:

Whip antennas are used to determine the level of interference caused by the radar to shipboard receivers. These antennas have the following characteristics (refer to impedance charts attached):

Length	Test Frequency (Hz)	Impedance (Ω)	θ	R (Ω)	C or L
6 m	500.5 k	1 k	-90°	0	80 pF
6 m	1.992 M	1.25 k	-86°	87.2	64 pF
6 m	10.00204 M	158		109	140 pF
4 m	27.5 M	95		83.5	128 pF
5/8 λ	150 M	116.5		105.5	52.5 nH
1/4 λ	450 M	70.5		34.5	5.68 pF

9.2 **Test Site:** Rooftop of 6-story building,
Furuno Electric Company, Ltd.
Ashihara-cho 9-52, Nishinomiya-city, 662-8580 JAPAN

9.3 Measuring Instruments:

- (1) RF Vector Impedance Meter, HP 4815A
- (2) Spectrum Analyzer, ADVANTEST TR4172
- (3) Spectrum Analyzer, HP 8566B
- (4) Antennas,
for 14 k - 10 MHz, 6 m whip
for 10 - 30 MHz, 4 m whip
for 30 - 300 MHz, VHF whip
for 300 - 1000 MHz, UHF whip

9.4 Test Results:

Interference levels to the respective antenna were measured at 2 m from the radar which was put in OFF, STANDBY, TRANSMIT conditions., and found within the specified limits.

9.4.1 Harmful Interference to Receiver (FCC Rule § 80.217 (a))

Limits: for 14 - 490 kHz, 5 $\mu\text{V}/\text{m}$
 for 490 kHz - 1 GHz, 1 $\mu\text{V}/\text{m}$

Results: There is no spurious component which is deemed harmful interference. (Test data are shown in ATTACHMENT 3)

9.4.2 Electromagnetic Field (FCC Rule § 80.217 (b) - 1)

Limits: for below 30 MHz, 0.1 $\mu\text{V}/\text{m}$ at 1 nm (-20 dB $\mu\text{V}/\text{m}$)
 for 30 to 100 MHz, 0.3 $\mu\text{V}/\text{m}$ at 1 nm (-10.5 dB $\mu\text{V}/\text{m}$)
 for 100 to 300 MHz, 1.0 $\mu\text{V}/\text{m}$ at 1 nm (0 dB $\mu\text{V}/\text{m}$)
 for over 300 MHz, 3.0 $\mu\text{V}/\text{m}$ at 1 nm (9.5 dB $\mu\text{V}/\text{m}$)

Results: Interference was measured with the antenna located 2 m from the radar and converted to levels at 1 nm. There is no spurious component exceeding the limits.
(Test data are shown in ATTACHMENT 3)

9.4.3 Power Input to an Artificial Antenna (FCC Rule § 80.217 (b) - 2)

Limits: for below 30 MHz, 400 μW
 for 30 to 100 MHz, 4,000 μW
 for 100 to 300 MHz, 40,000 μW
 for over 300 MHz, 400,000 μW

Results: There is no spurious component exceeding the limits.
(Test data are shown in ATTACHMENT 3)

MEASUREMENT OF IMPEDANCE OF TEST ANTENNAS

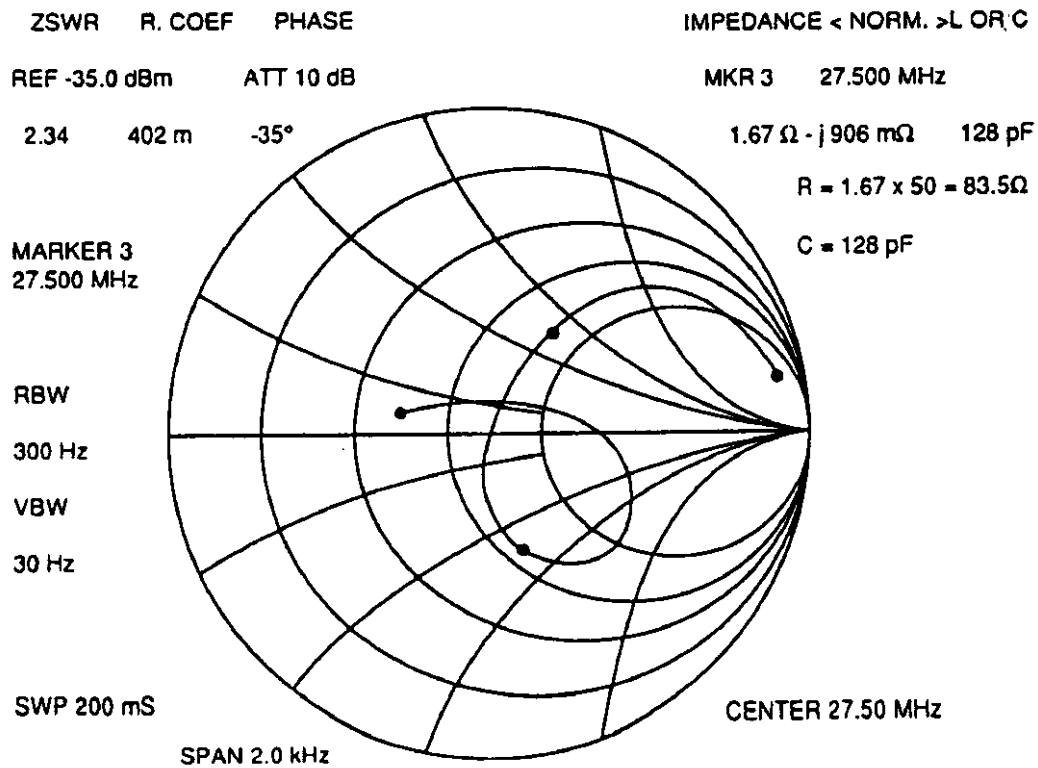
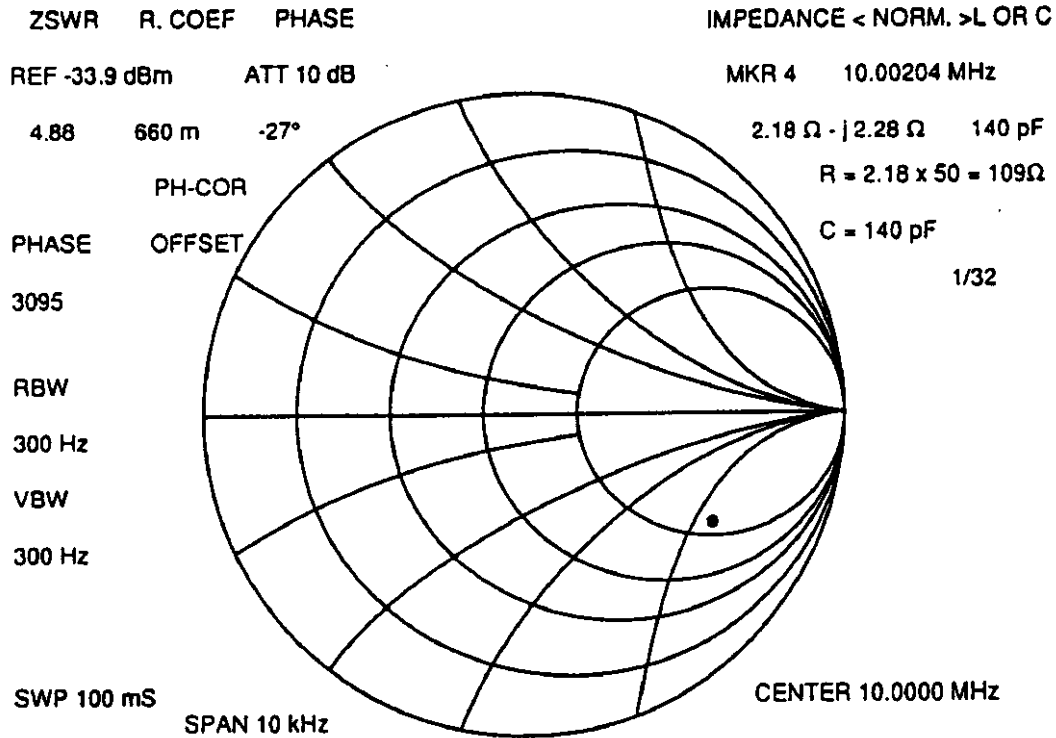

MEASUREMENT OF IMPEDANCE OF TEST ANTENNAS

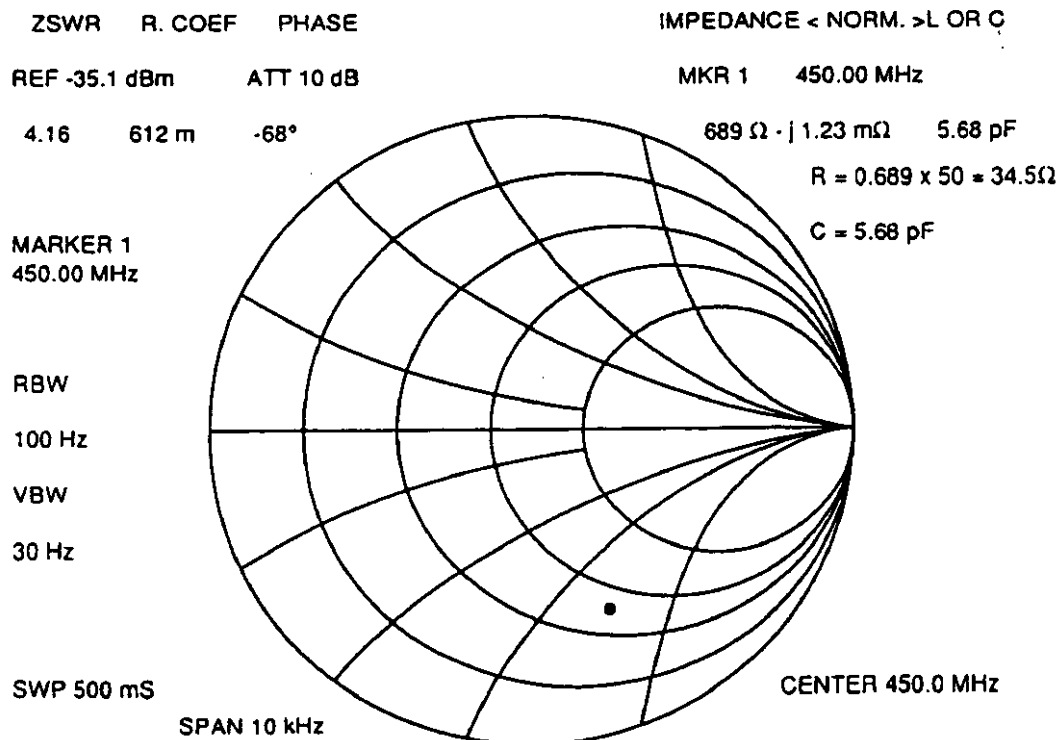
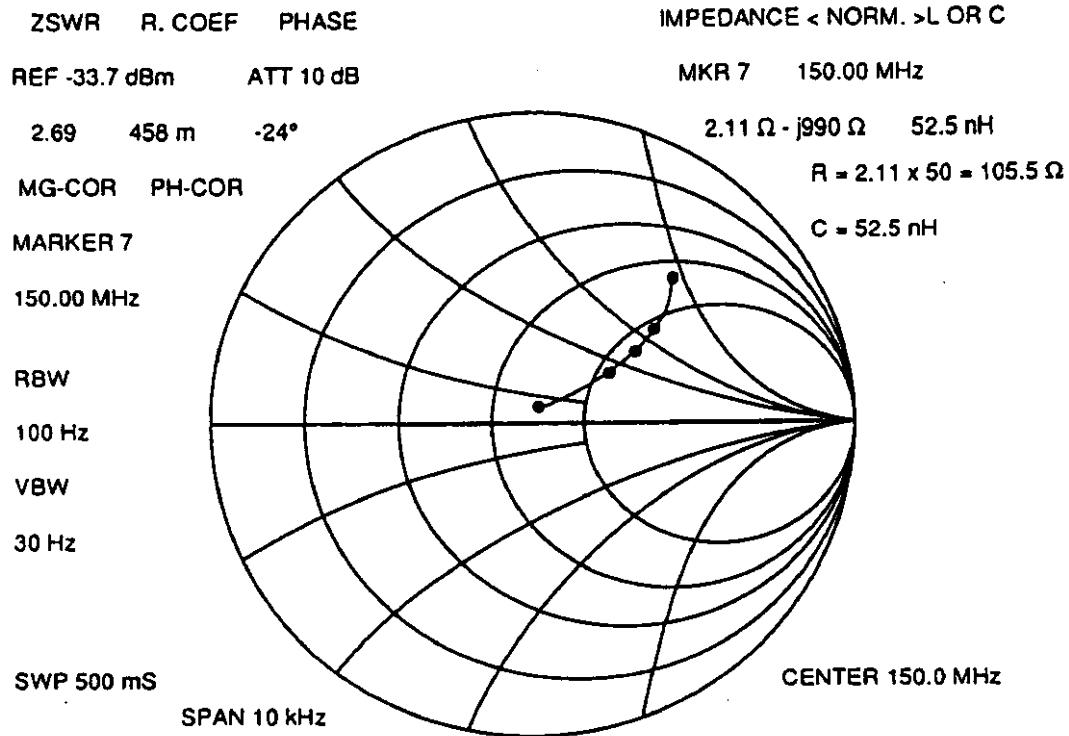



11 TECHNICAL DESCRIPTION OF EQUIPMENT (FCC Rules § 2.983)

11.1 Function of Each Semiconductor or Active Device (FCC Rule § 2.983 (d)(6))

ANTENNA UNIT

TRANSCEIVER MODULE (RTR-062)

Modulator Trigger PCB 03P9243 (RFC)

CR1 - CR4,	
CR6 - CR9:	Over-Voltage & Reverse-Voltage Protection
CR5:	Reverse-Voltage Protection
Q1 - Q12, Q15:	Current Amplifier
Q13 - Q14:	Buffer Amplifier
U1:	+5 V Regulator
U2:	Inverter Gate
U3:	Monostable Multivibrator
U4:	PLD
U5:	Oscillator
U6:	NAND Gate
U7:	Regulator
U8:	Photo-Coupler
U9 - U10:	Comparator

Modulator PCB 03P9244 (MD)

CR1 - CR3, CR5:	Reverse-Voltage Protection
CR4:	Rectifier
Q1-Q4, Q21:	Switching
Q5 - Q20:	FET Gate Driver
U1:	Regulator
U2:	Photo-Coupler

Chassis Mounted Parts

CR870 - CR871:	Clipper
CR880:	Limiter
HY801:	3 Ports Circulator
U801:	MIC Frequency Converter with Limiter
V801:	Magnetron

IF Amplifier PCB 03P9232 (IF)

CR601-CR607:	Switching
CR608:	Over-Voltage Protection
CR609:	Protector
CR616:	DC Restoring
CR622:	Thermal Compensation
CR626:	Clamp
CR629-CR630:	Over-Voltage Protection
Q601-Q602:	IF Amplifier in Cascade Connection
Q603:	Switching
Q609-Q610:	IF Amplifier in Cascade Connection
Q614-Q615:	IF Amplifier in Cascade Connection
Q616:	Bias Fix
Q617:	Detector
Q618:	Current Buffer
Q619 - Q620:	Tuning Indication Amplifier
Q625-Q628:	Video Amplifier
Q630:	Emitter-follower Amplifier
Q631:	Over-Voltage Protection
Q635-Q636:	Switching
U601-U603:	IF Amplifier
U604:	Band Width Select Comparator
U605-U609:	DC Regulator
U610:	IF Amplifier
U611:	Pulse Generator
U612:	Inverter

Bearing Signal Generator PCB MP-3795

Q901 - Q902:	Pulse Amplifier
U901:	Photo Interrupter
U902:	Comparator

11.2 Description of the circuits employed for suppression of spurious radiation, for limiting or shaping the control pulse, and for limiting or controlling power

(FCC Rule § 2.983 (d) (11))

ANTENNA UNIT

TRANSCEIVER MODULE (RTR-062)

Modulator Trigger Circuit 03P9243 (RFC)

The modulator trigger generates the pulses that fire the modulator FETs.

The pulse forming circuit of U2 to U6 produces the four trigger pulses TRIG1 to TRIG4, the pulselength of which differ depending on the setting of pulselength (P/L A, P/L B and P/L C). For short pulse 1 (SP1), TRIG1 to TRIG4 have same length (0.12 μ s). For short pulse 2 (SP2), middle pulse 1 (MP1), middle pulse 2 (MP2) and middle pulse 3 (MP3), TRIG1 to TRIG4 have different length (between 0.10 to 1.04 μ s). For long pulse (LP), TRIG1 to TRIG4 have same pulselength (1.2 μ s). These pulses are sent to the modulator board.

U4 also produces the bandwidth selection signals (BW:S, BW:L), which are sent to the IF amplifier for bandwidth selection.

The circuit composed of U7, U8 and Q15 is provided to regulate the magnetron heater voltage.

The U10 is a current amplifier to detect the average magnetron current.

Modulator Board 03P9244 (MD)

The function of the modulator board is to produce a high tension pulse that drives the magnetron.

The high voltage (TX-HV) is charged into C1 to C4 through R1/R2 while the magnetron is inactive. This high voltage is discharged through the pulse transformer T801 when FETs Q1 - Q4 are conductive. T801 boosts the voltage and makes the magnetron oscillate.

Because the magnetron oscillates only when the FET is conductive, transmission pulselength can be changed by the pulselength fed to the gates of FETs.

Also the magnetron current is proportional to the discharging current via the FETs, thus the transmission power can be changed by the number of FETs conductive.

The four pulses TRIG1 to TRIG4 are produced on the modulator board and applied to the gates of Q1/Q2/Q3/Q4 via the current amplifier Q7/Q11/Q15/Q19.

The relay K1 and coil L1 are provided to eliminate the ringing at the trailing edge of the transmission pulse across the primary winding of T801. This relay is active when the short pulse 1 (SP1) is selected.

Duplexer and Mixer

Since the radar system uses a single antenna for transmission and reception, an efficient device is required for switching the transmitter and the receiver, this radar employs circulator HY801. The circulator HY801 is a passive directional coupler with three ports. The incoming signal is bent in the specific direction and emerges from another port with little loss, the other port being isolated. In the same manner, the received signal entering into another port is transferred to the other port, isolating one port. This operation of the circulator protects the receiver during transmission and minimizes loss of the received signal during reception.

The diode limiter is a self-activating switch made of two PIN diodes. Its function is to attenuate the strong transmission signals from the magnetron and other boat radars through the antenna and to protect the MIC (microwave IC) U801. The PIN diode conducts at a certain level of microwave power. When the diode is the cut-off state, the input impedance of the diode limiter matches the impedance of the waveguide, and the microwave energy is delivered to the MIC. When the diode is put into a conductive state, the waveguide is short-circuited and most of the input energy is reflected back to the transmitter side. The strong signal is thus weakened down to about 50 mW by the diode limiter.

U801 is a microwave IC (MIC) incorporating a local oscillator and mixer diodes. The received microwave signal of 9410 MHz coming from the diode limiter is mixed with the local oscillation signal in the mixer diodes and converted to IF signal of 60 MHz.

IF Amplifier 03P9232 (IF)

The IF signal of 60 MHz coming from the MIC is amplified and converted into a video signal, which is delivered to the display unit.

The IF amplifier is composed of six major circuits; Linear Amplifier (Q601/Q602/Q609/Q610), Logarithmic Amplifier(U601/U602/U603/U610), Video Amplifier (Q625/Q626/Q627/Q628), Bandwidth Selector (U604, CR601 to CR607), Tuning Indicator Circuit (Q614 to Q620) and Main Bang Suppression Circuit (Q630, Q631, Q603, CR631, CR626, CR608, CR609, U611, U612).

The signal applied to the base of Q601 is amplified in cascade by Q601 and Q602, and sent to the bandwidth selector.

The IF amplifier operates in narrow or wide bandwidth mode depending on the settings of the RANGE switch and TX touchpad. For short ranges, a wide bandwidth (27 MHz) is selected, since the levels at pin #3 of U604 and pin #6 of U604 go high, thus CR602 to CR605 and CR607 are conductive and CR601/CR606 are cut off, causing the signal to pass through CR603/CR604. On the contrary, CR602 to CR605 and CR607 are cut off and CR601/CR606 are conductive, which causes the signal to pass through T603/T604, selecting a narrow bandwidth (3 MHz) on medium and long ranges.

The signal through the bandwidth selector is coupled to the logarithmic amplifier, amplified and detected by U601/U602/U610. Thus, the detected signals are fed to Q625/Q626 to be amplified further, and then sent to the display unit via buffers Q627, Q628.

The IF signal of 60 MHz is amplified by Q609/Q610, U603, Q614/Q615 and detected by Q617. Then the detected signal (Tuning Indicator Signal) is sent to the display unit via Q618 to Q620.

On the other hand, Q609/Q610 and U603 are additional amplifier circuits to make the dynamic range of the IF signal wider, causing the discrimination of the target echoes to get better. The IF signal from the MIC is fed to Q609/Q610 as well as through resistor R651 which is employed to attenuate the signal level. Therefore, Q609/Q610 amplifies even a strong signal which may be saturated in Q601/Q602 and U601/U602, and then sent to logarithmic amplifier U603. This signal is added to the saturated signal in U601/U602, causing the saturation level of the IF signal to become high.

The purpose of main bang suppression circuit is to minimize transmission leakage near the center spot on the screen.

When the magnetron current pulse generated in Modulator board 03P9244 is fed to inverter U612, pulse generator U611 produces a modified rectangular pulse.

This pulse is fed to the emitter of Q603 through Q630 as a main bang suppression waveform, then Q602 turns off during transmission to eliminate direct reception of the strong TX energy (main bang).

Bearing Signal Generator MP-3795

The bearing signal generator produces a square wave signal that is used to synchronize the sweep rotation with that of the antenna.

U901 is a photo interrupter composed of a light emitting diode and a photo transistor. It has a configuration in the shape of "U" shape. The light emitting diode is mounted on one wall of the "U" shape and the photo transistor on the other wall. A rotating timing disc is arranged between the two walls.

The timing disc is provided with 60 slits at regular intervals along its circumference. It is fitted on the scanner motor shaft and rotated at a speed of 144 rpm by the 24 rpm scanner motor.

LABOTECH

Furuno Labotech International

Report no. : FLI 12-98-019

The photo transistor receives the light emitted by the light emitting diode through each slit of the timing disc and converts it into electric current. The output of the photo transistor across R903 is a half-rectified sine wave at a frequency of 144 Hz. This signal is amplified, reshaped and sent to the display unit for display echo synchronization.

12 OPERATOR'S MANUAL INCL. CIRCUIT DIAGRAMS (FCC Rule § 2.983)

(See separate covers)

1

2

ATTACHMENT 1

[TEST DATA FOR 6. SPURIOUS EMISSIONS AT ANTENNA TERMINALS]

1. Spurious emissions for 0.125 nm Range:

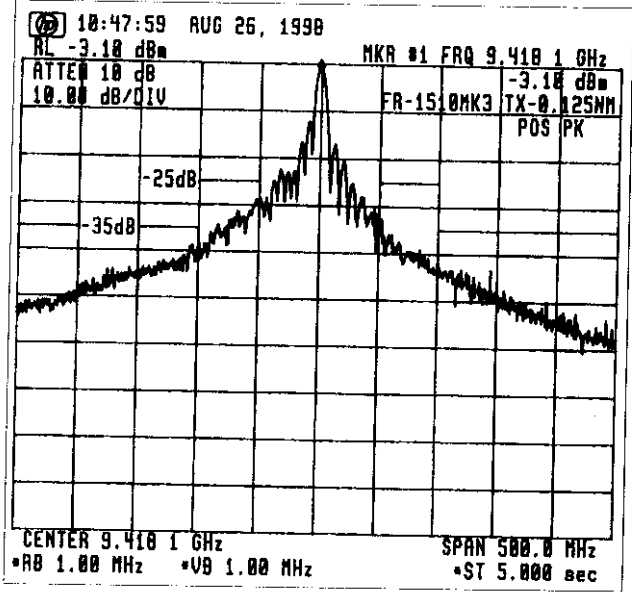

Ref. level: -3.1 dBm

Emission limitations:

- (a) 25 dB for 50 to 100 % of the authorized BW (100 MHz)
- (b) 35 dB for 100 to 250 % of the authorized BW (100 MHz)

Fig. 1.1 Without Filter

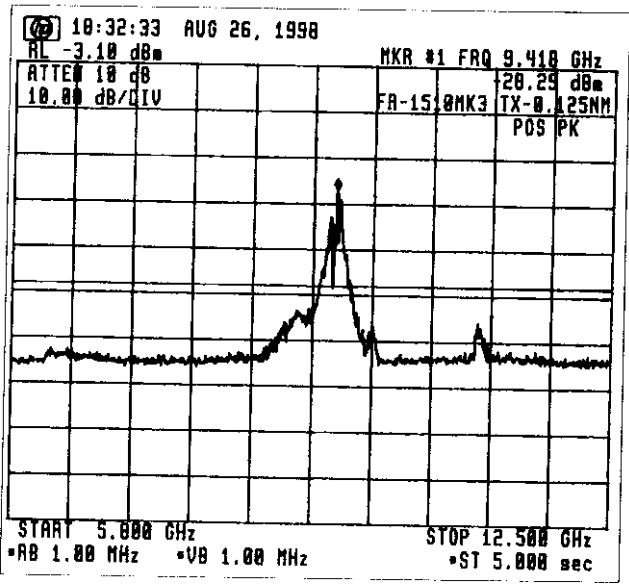

Emission limitations:

- (c) $43 + 10 \log P_m = 47.69 \text{ dB}$ for more than 250 % of the authorized BW (100 MHz)

Fig. 1.2 With Filter No.1

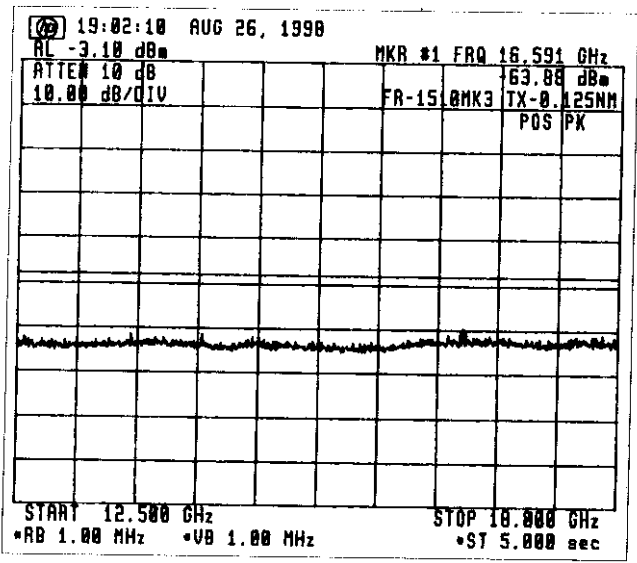

Emission limitations:

- (c) $43 + 10 \log P_m = 47.69 \text{ dB}$ for more than 250 % of the authorized BW (100 MHz)

Fig. 1.3 With Filter No. 2

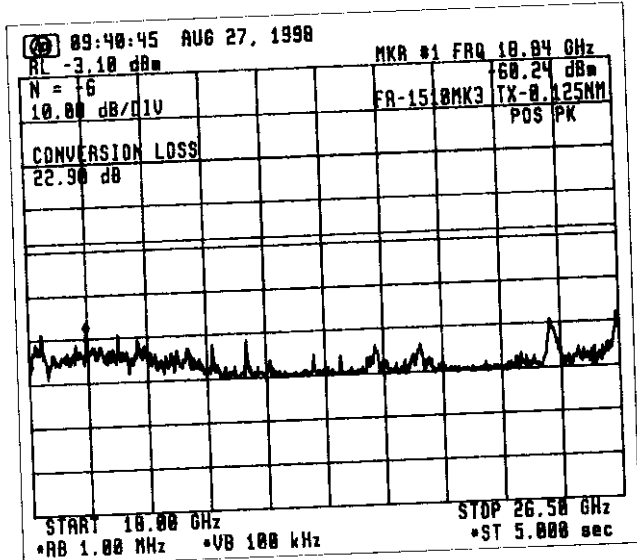

Emission limitations:

- (c) $43 + 10 \log P_m = 47.69 \text{ dB}$
for more than 250 % of
the authorized BW (100 MHz)

Fig. 1.4 With Filter No. 2

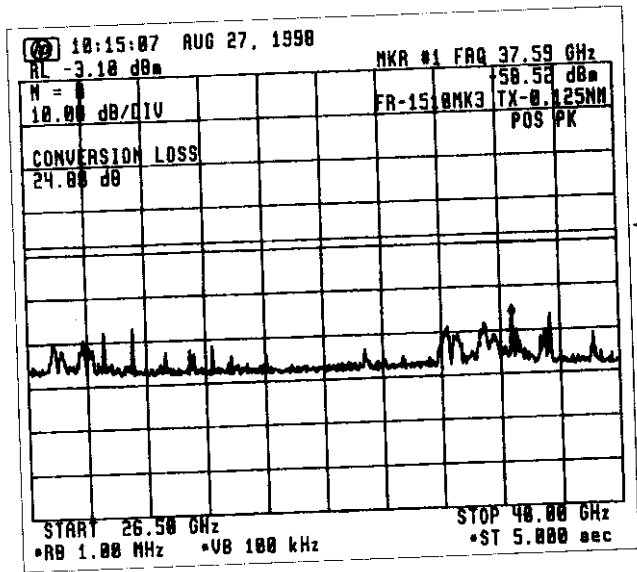

Emission limitations:

- (c) $43 + 10 \log P_m = 47.69 \text{ dB}$
for more than 250 % of
the authorized BW (100 MHz)

Fig. 1.5 With Filter No. 2

2. Spurious emissions for 0.5 nm Range:

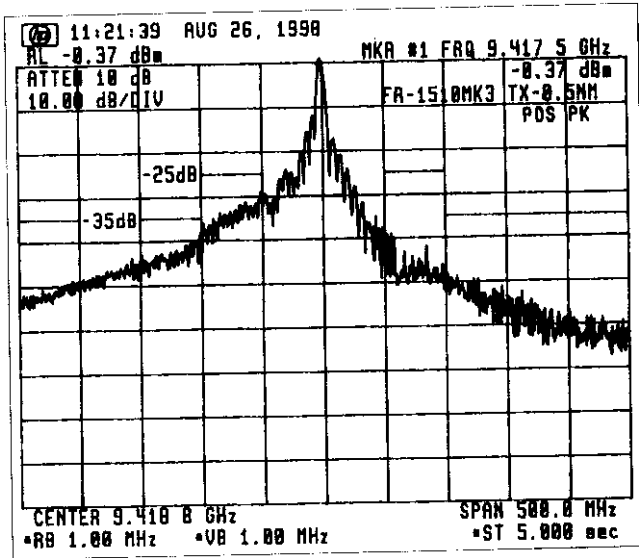

Ref. level: -0.37 dBm

Emission limitations:

- ← (a) 25 dB for 50 to 100 % of the authorized BW (100 MHz)
- ← (b) 35 dB for 100 to 250 % of the authorized BW (100 MHz)

Fig. 2.1 Without Filter

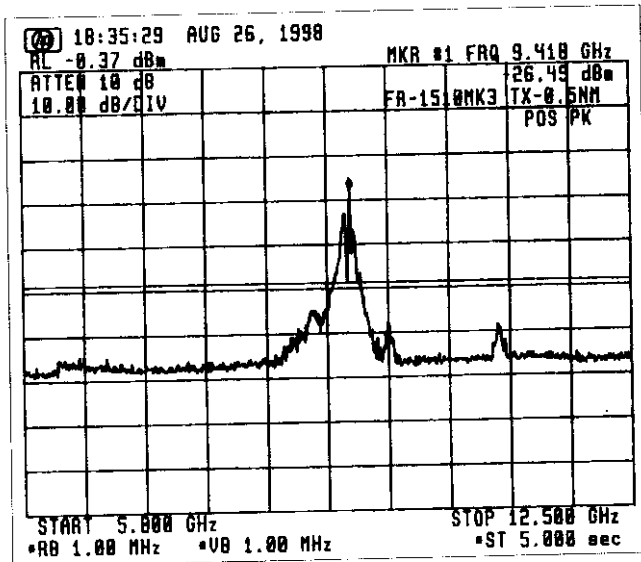

Emission limitations:

- ← (c) $43 + 10 \log P_m = 48.58 \text{ dB}$ for more than 250 % of the authorized BW (100 MHz)

Fig. 2.2 With Filter No.1

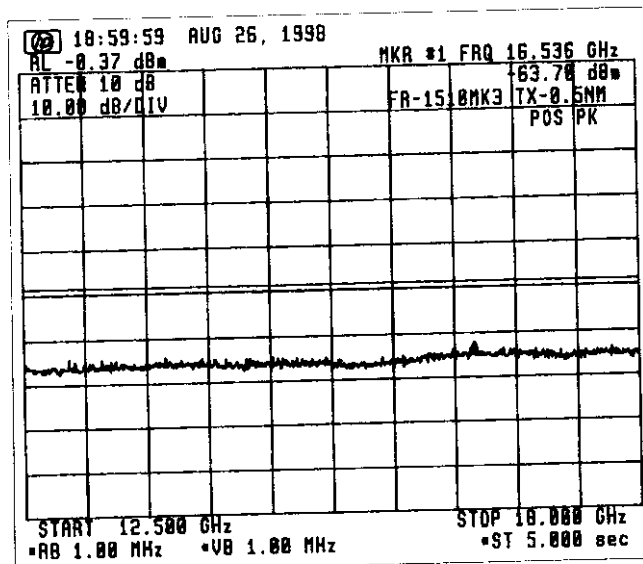

Emission limitations:

- ← (c) $43 + 10 \log P_m = 48.58 \text{ dB}$ for more than 250 % of the authorized BW (100 MHz)

Fig. 2.3 With Filter No. 2

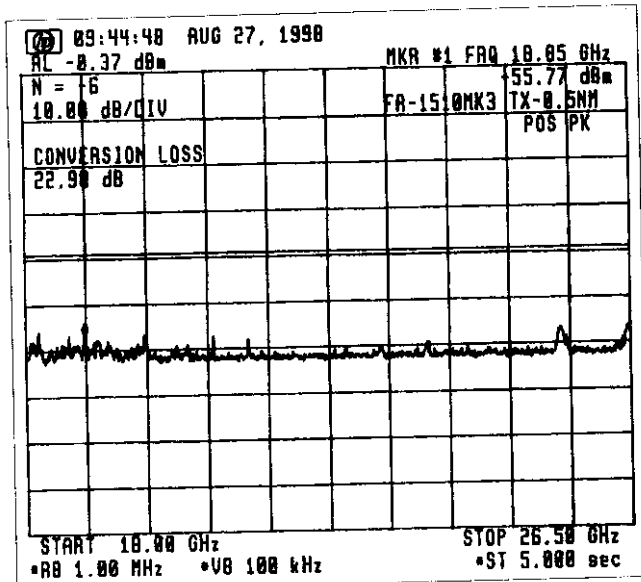

Emission limitations:

- (c) $43 + 10 \log P_m = 48.58 \text{ dB}$
for more than 250 % of
the authorized BW (100 MHz)

Fig. 2.4 With Filter No. 2

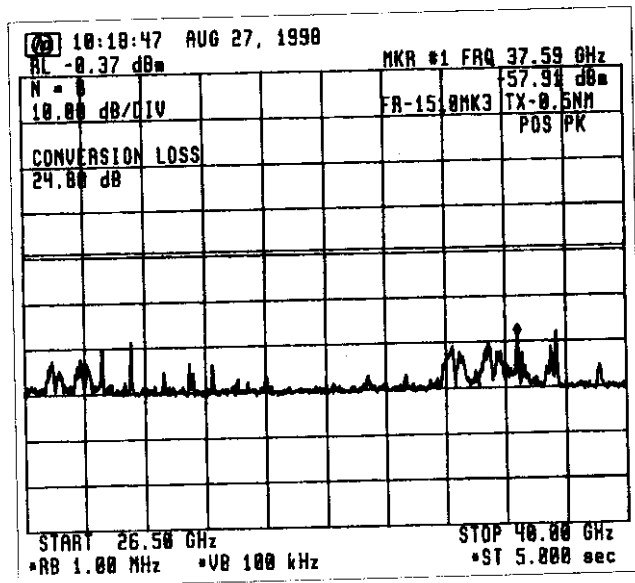

Emission limitations:

- (c) $43 + 10 \log P_m = 48.58 \text{ dB}$
for more than 250 % of
the authorized BW (100 MHz)

Fig. 2.5 With Filter No. 2

3. Spurious emissions for 0.75 nm Range:

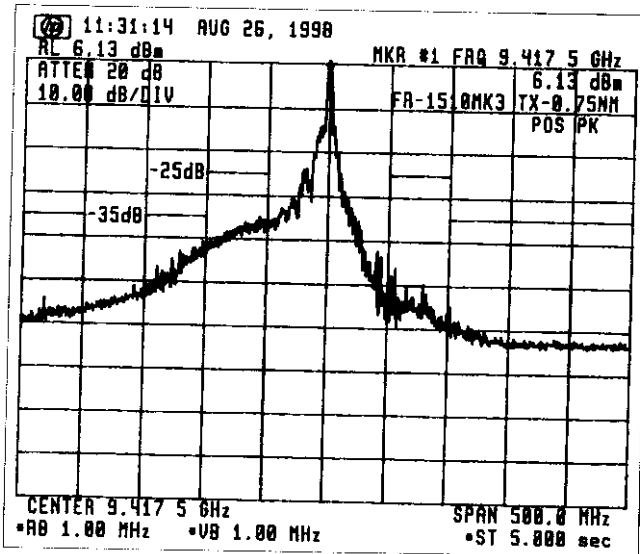

Ref. level: 6.13 dBm

Emission limitations:

- (a) 25 dB for 50 to 100 % of the authorized BW (100 MHz)
- (b) 35 dB for 100 to 250 % of the authorized BW (100 MHz)

Fig. 3.1 Without Filter

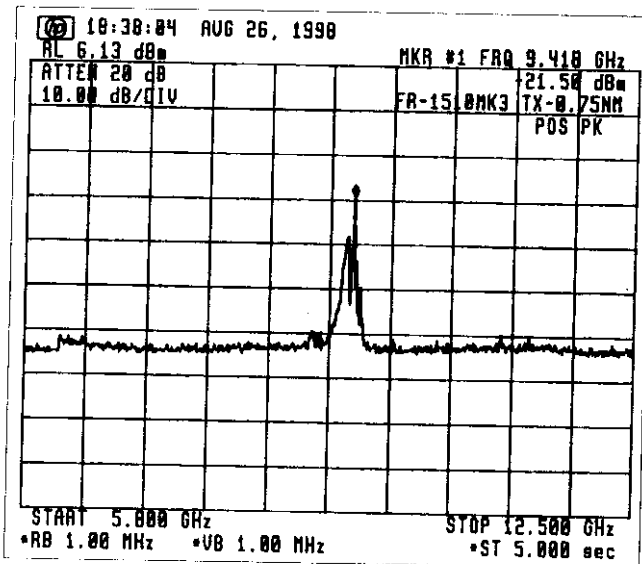

Emission limitations:

- (c) $43 + 10 \log P_m = 49.63 \text{ dB}$ for more than 250 % of the authorized BW (100 MHz)

Fig. 3.2 With Filter No.1

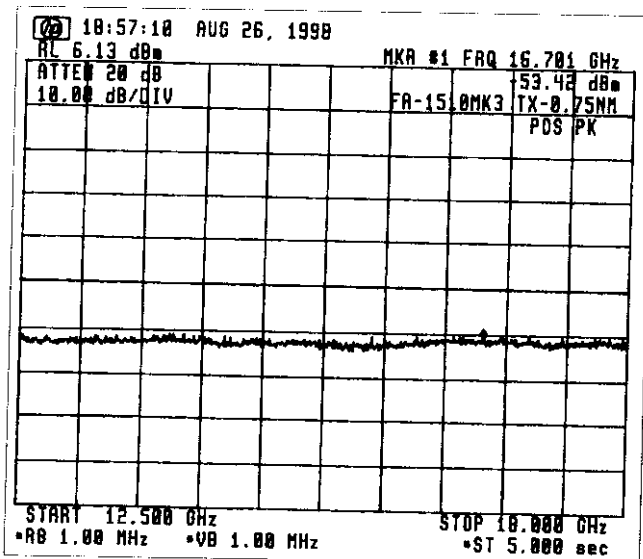

Emission limitations:

- (c) $43 + 10 \log P_m = 49.63 \text{ dB}$ for more than 250 % of the authorized BW (100 MHz)

Fig. 3.3 With Filter No.2

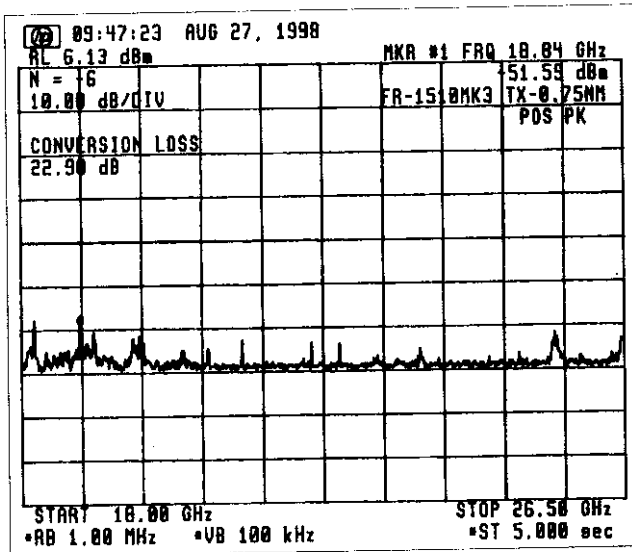

Emission limitations:

- (c) $43 + 10 \log P_m = 49.63 \text{ dB}$
 for more than 250 % of
 the authorized BW (100 MHz)

Fig. 3.4 With Filter No. 2

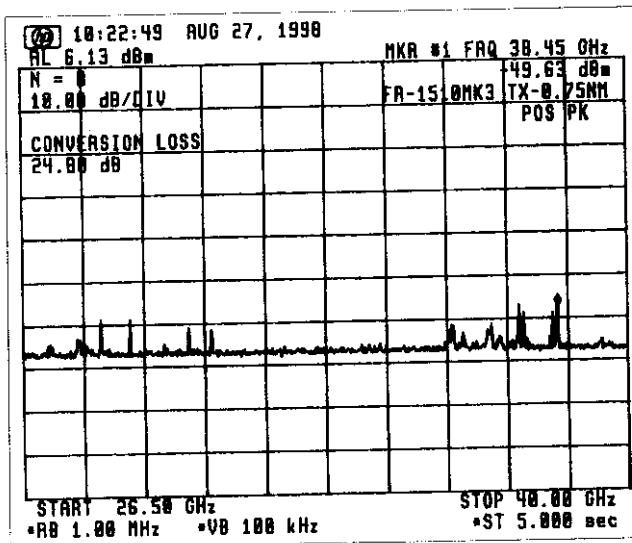

Emission limitations:

- (c) $43 + 10 \log P_m = 49.63 \text{ dB}$
 for more than 250 % of
 the authorized BW (100 MHz)

Fig. 3.5 With Filter No. 2

4. Spurious emissions for 6 nm Range:

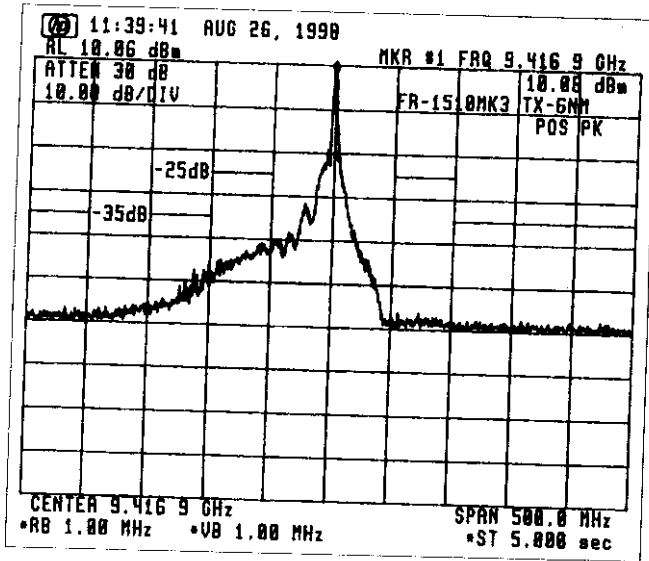

Ref. level: 10.06 dBm

Emission limitations:

- (a) 25 dB for 50 to 100 % of the authorized BW (100 MHz)
- (b) 35 dB for 100 to 250 % of the authorized BW (100 MHz)

Fig. 4.1 Without Filter

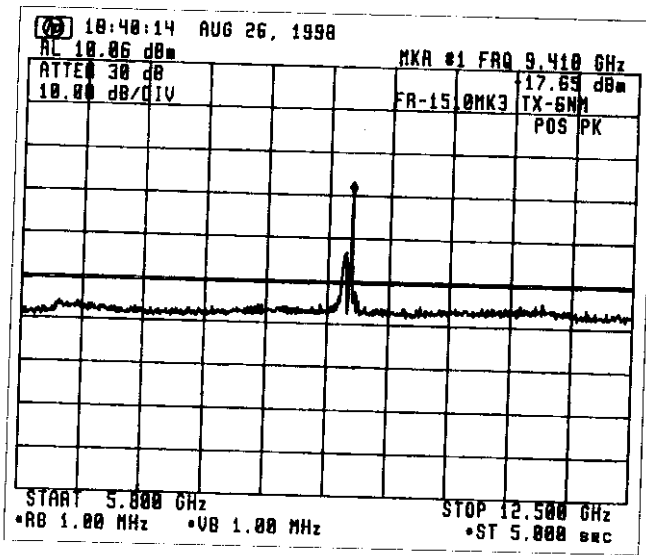

Emission limitations:

- (c) $43 + 10 \log P_m = 50.27 \text{ dB}$ for more than 250 % of the authorized BW (100 MHz)

Fig. 4.2 With Filter No.1

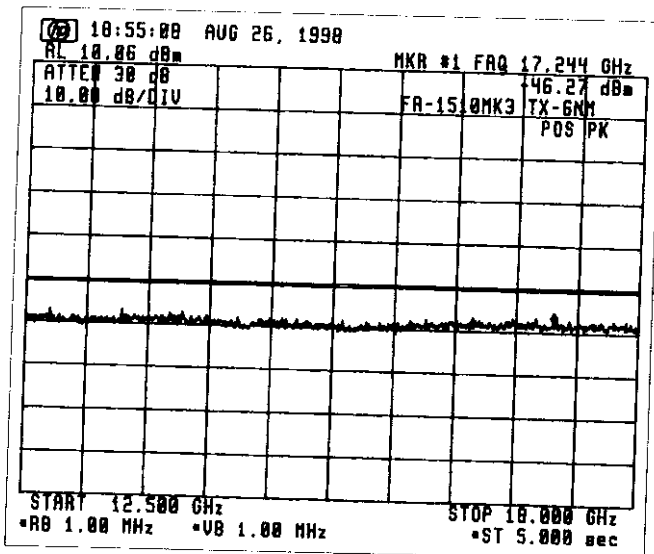

Emission limitations:

- (c) $43 + 10 \log P_m = 50.27 \text{ dB}$ for more than 250 % of the authorized BW (100 MHz)

Fig. 4.3 With Filter No. 2

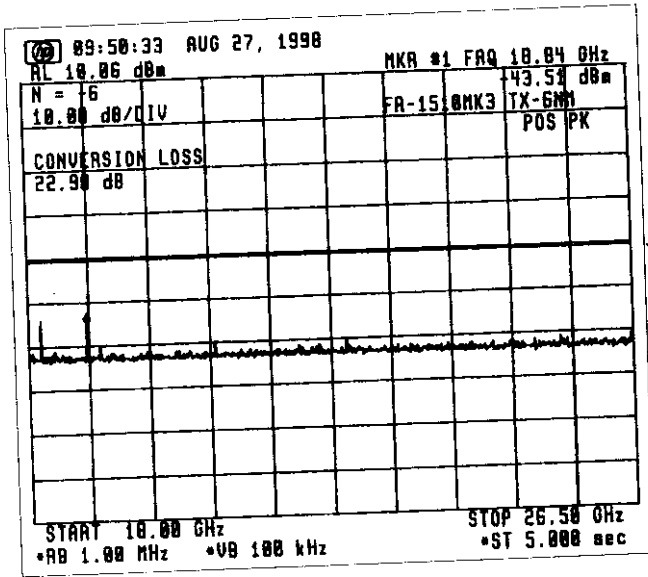

Emission limitations:

- (c) $43 + 10 \log P_m = 50.27 \text{ dB}$
for more than 250 % of
the authorized BW (100 MHz)

Fig. 4.4 With Filter No. 2

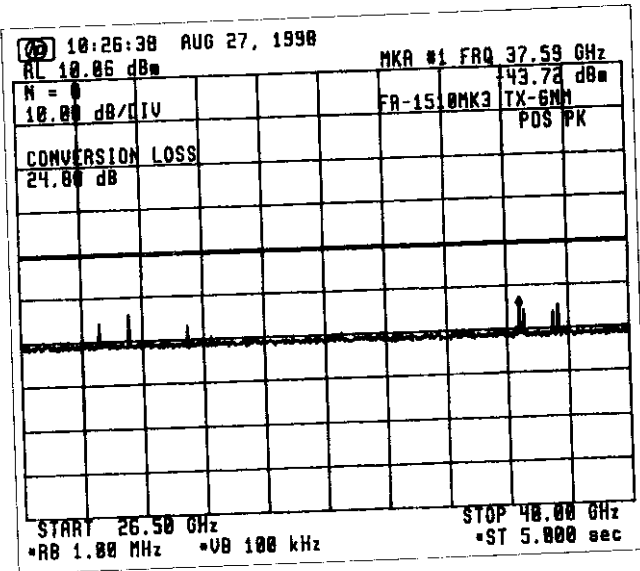

Emission limitations:

- (c) $43 + 10 \log P_m = 50.27 \text{ dB}$
for more than 250 % of
the authorized BW (100 MHz)

Fig. 4.5 With Filter No. 2

5. Spurious emissions for 12 nm Range:

Ref. level: 12.35 dBm

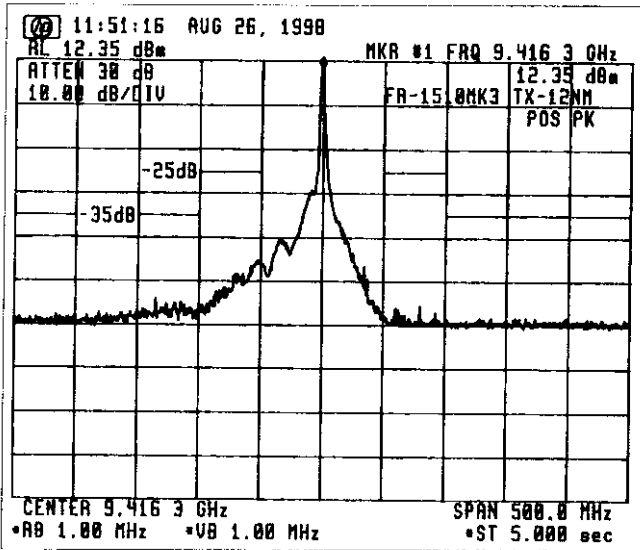

Emission limitations:

- (a) 25 dB for 50 to 100 % of the authorized BW (100 MHz)
- (b) 35 dB for 100 to 250 % of the authorized BW (100 MHz)

Fig. 5.1 Without Filter

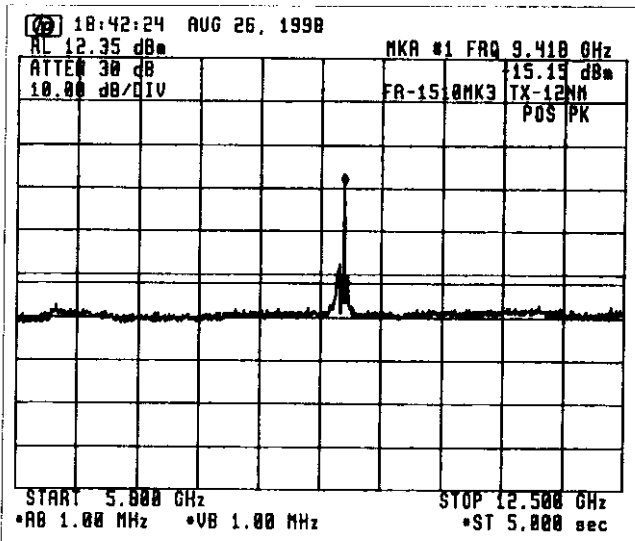

Emission limitations:

- (c) $43 + 10 \log P_m = 51.96 \text{ dB}$ for more than 250 % of the authorized BW (100 MHz)

Fig. 5.2 With Filter No.1

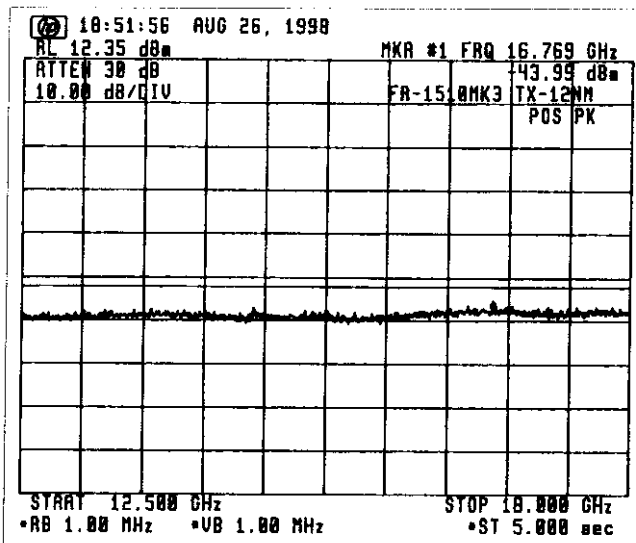

Emission limitations:

- (c) $43 + 10 \log P_m = 51.96 \text{ dB}$ for more than 250 % of the authorized BW (100 MHz)

Fig. 5.3 With Filter No. 2

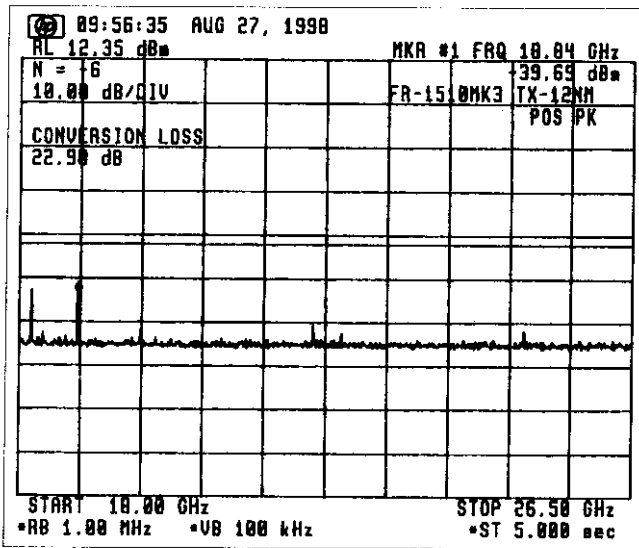

Emission limitations:

- ← (c) $43 + 10 \log P_m = 51.96 \text{ dB}$
 for more than 250 % of
 the authorized BW (100 MHz)

Fig. 5.4 With Filter No. 2

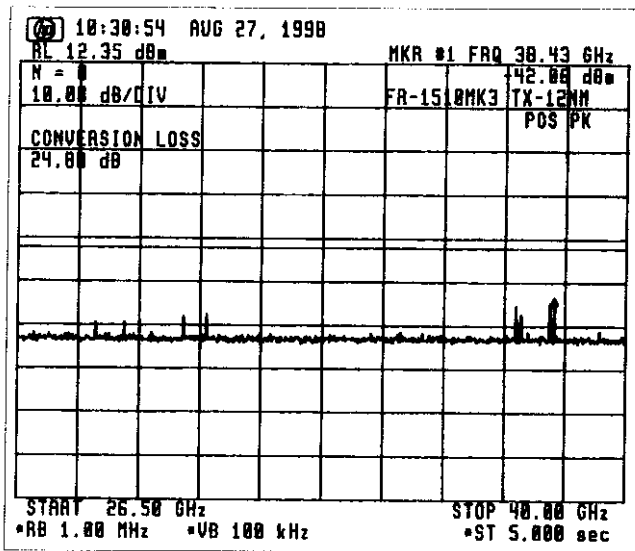

Emission limitations:

- ← (c) $43 + 10 \log P_m = 51.96 \text{ dB}$
 for more than 250 % of
 the authorized BW (100 MHz)

Fig. 5.5 With Filter No. 2

6. Spurious emissions for 96 nm Range:

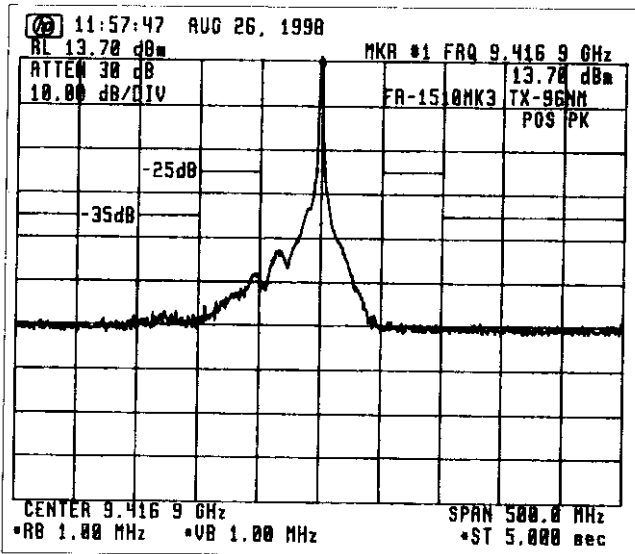

Ref. level: 13.7 dBm

Emission limitations:

- (a) 25 dB for 50 to 100 % of the authorized BW (100 MHz)
- (b) 35 dB for 100 to 250 % of the authorized BW (100 MHz)

Fig. 6.1 Without Filter

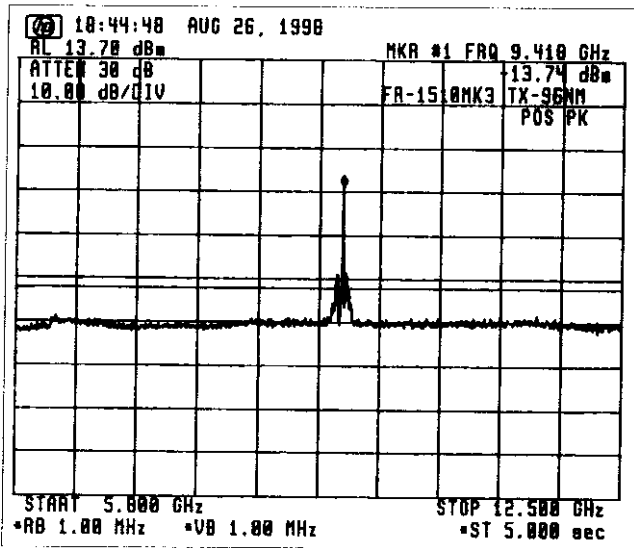

Emission limitations:

- (c) $43 + 10 \log P_m = 51.76 \text{ dB}$ for more than 250 % of the authorized BW (100 MHz)

Fig. 6.2 With Filter No.1

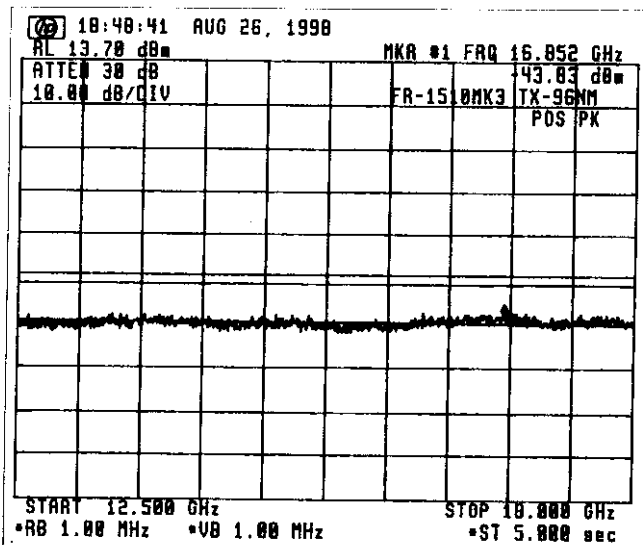

Emission limitations:

- (c) $43 + 10 \log P_m = 51.76 \text{ dB}$ for more than 250 % of the authorized BW (100 MHz)

Fig. 6.3 With Filter No. 2

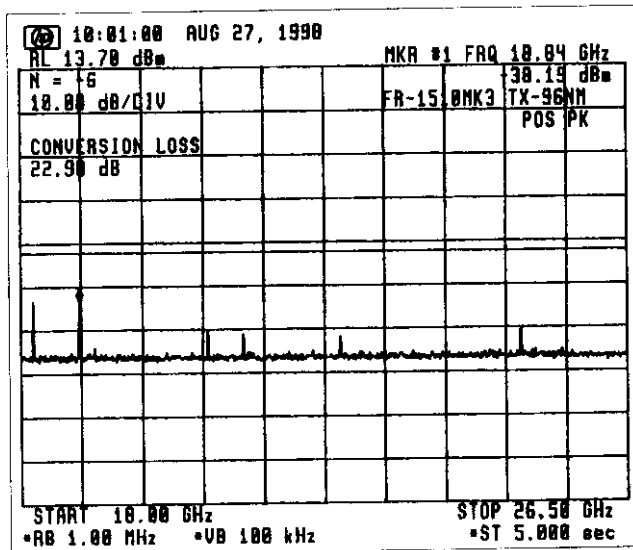

Emission limitations:

- (c) $43 + 10 \log P_m = 51.76 \text{ dB}$
 for more than 250 % of
 the authorized BW (100 MHz)

Fig. 6.4 With Filter No. 2

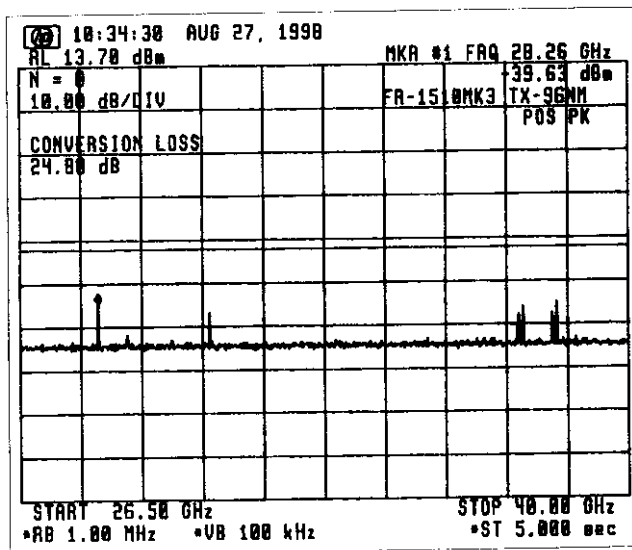

Emission limitations:

- (c) $43 + 10 \log P_m = 51.76 \text{ dB}$
 for more than 250 % of
 the authorized BW (100 MHz)

Fig. 6.5 With Filter No. 2

ATTACHMENT 2

FIELD STRENGTH

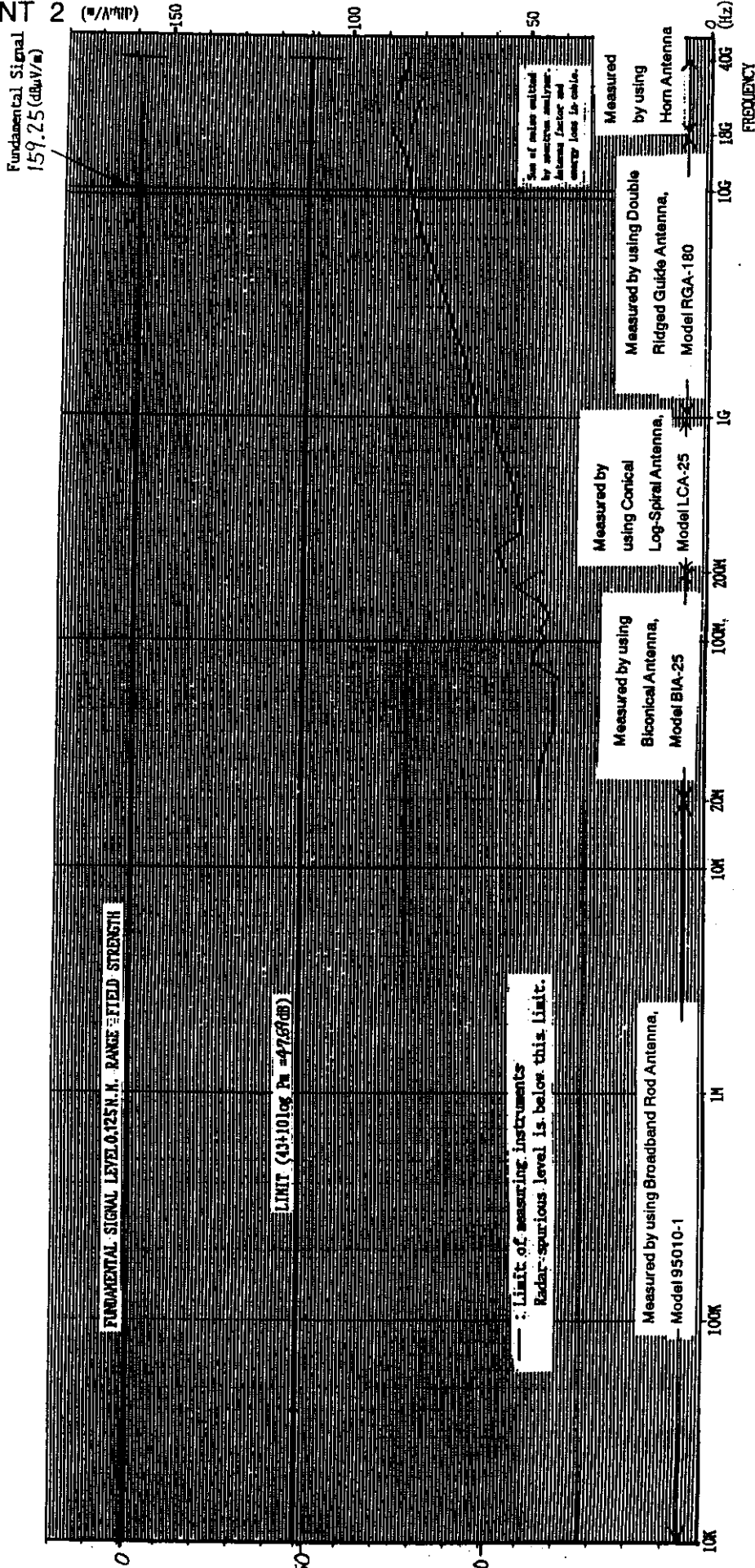

[TEST DATA FOR 7. FIELD STRENGTH OF SPOURIOUS RADIATION]

Graph 7-1 Field strength of spurious radiation measured with pick-up antenna (0.125 nm range)
(Short Pulse)

ATTEN. BELOW FUNDAMENTAL (dB)

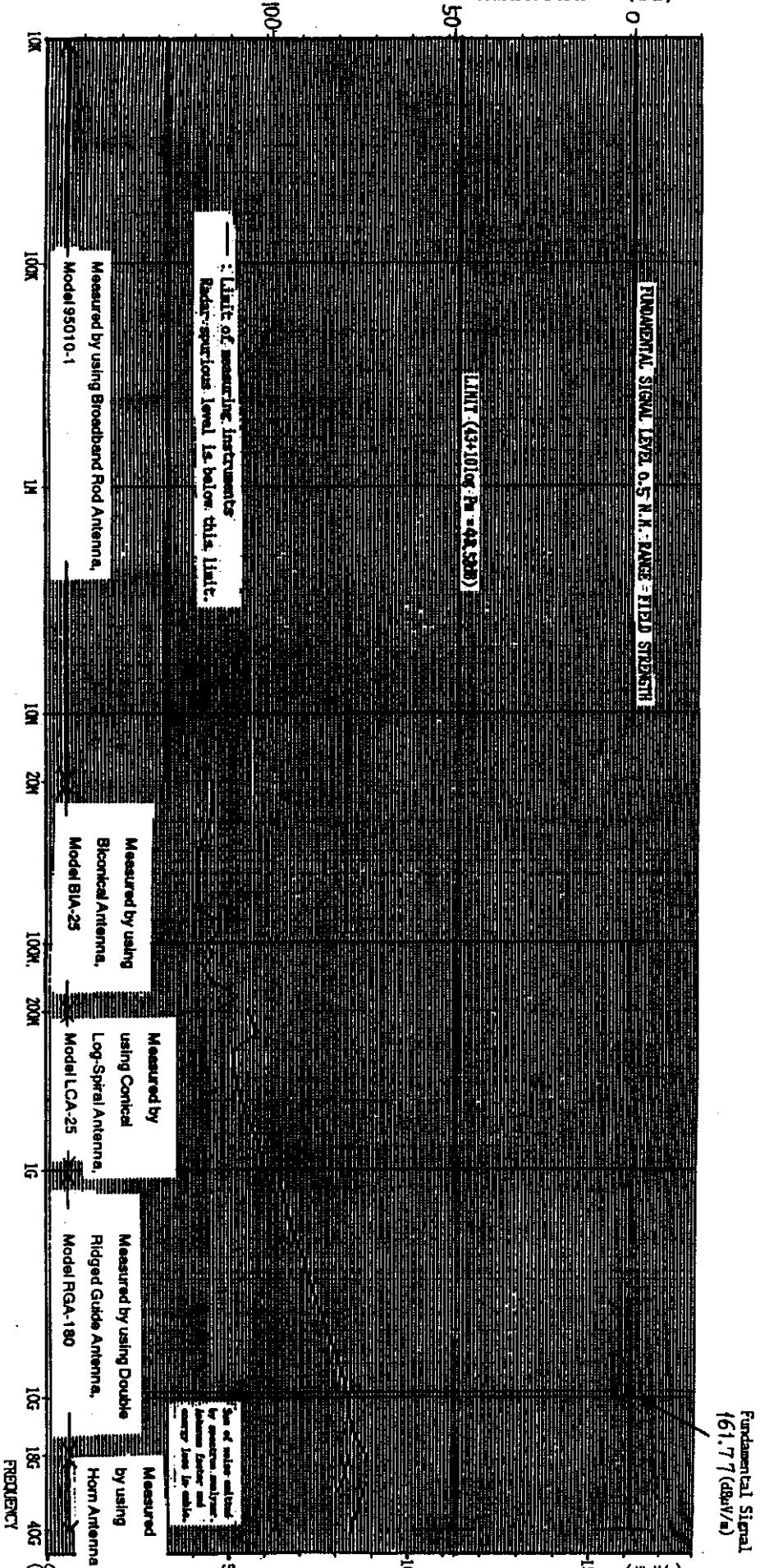

Graph 7-2 Field strength of spurious radiation measured with pick-up antenna (0.5 nm range) (Short 2 Pulse)

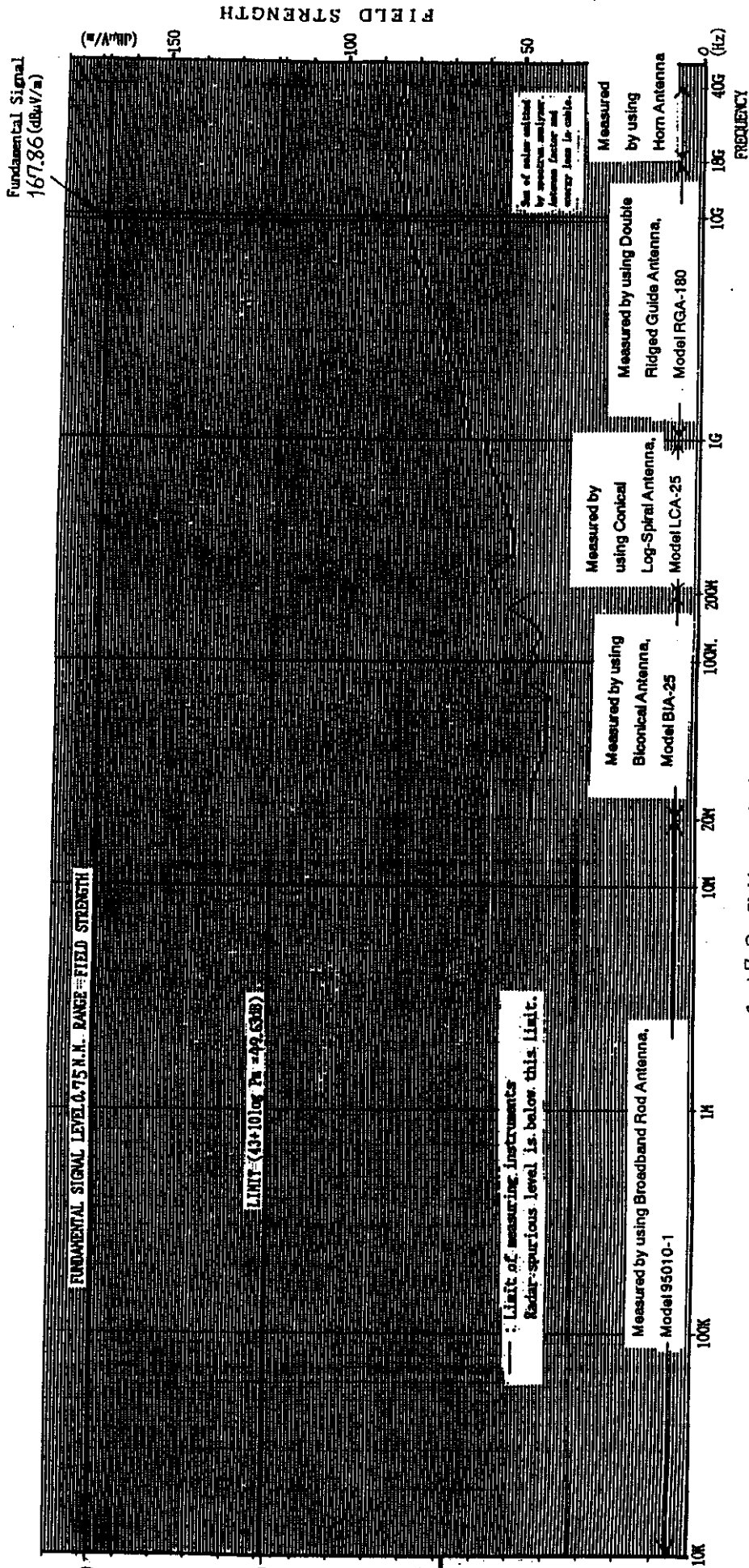

Graph 7-3 Field strength of spurious radiation measured with pick-up antenna (0.75 nm range) (Middle Pulse)

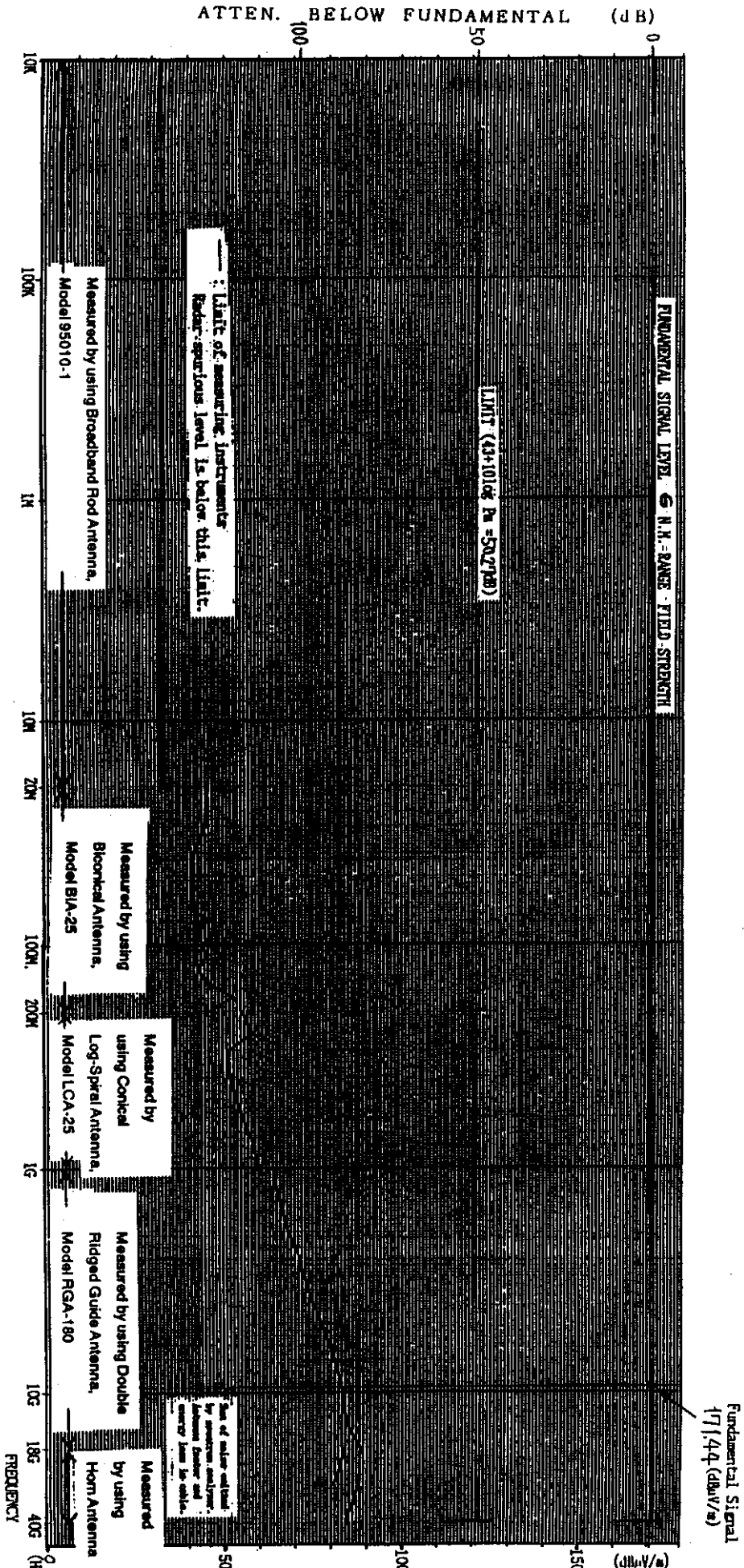

Graph 7-4 Field strength of spurious radiation measured with pick-up antenna (6 nm range)

(Middle 2 Pulse)

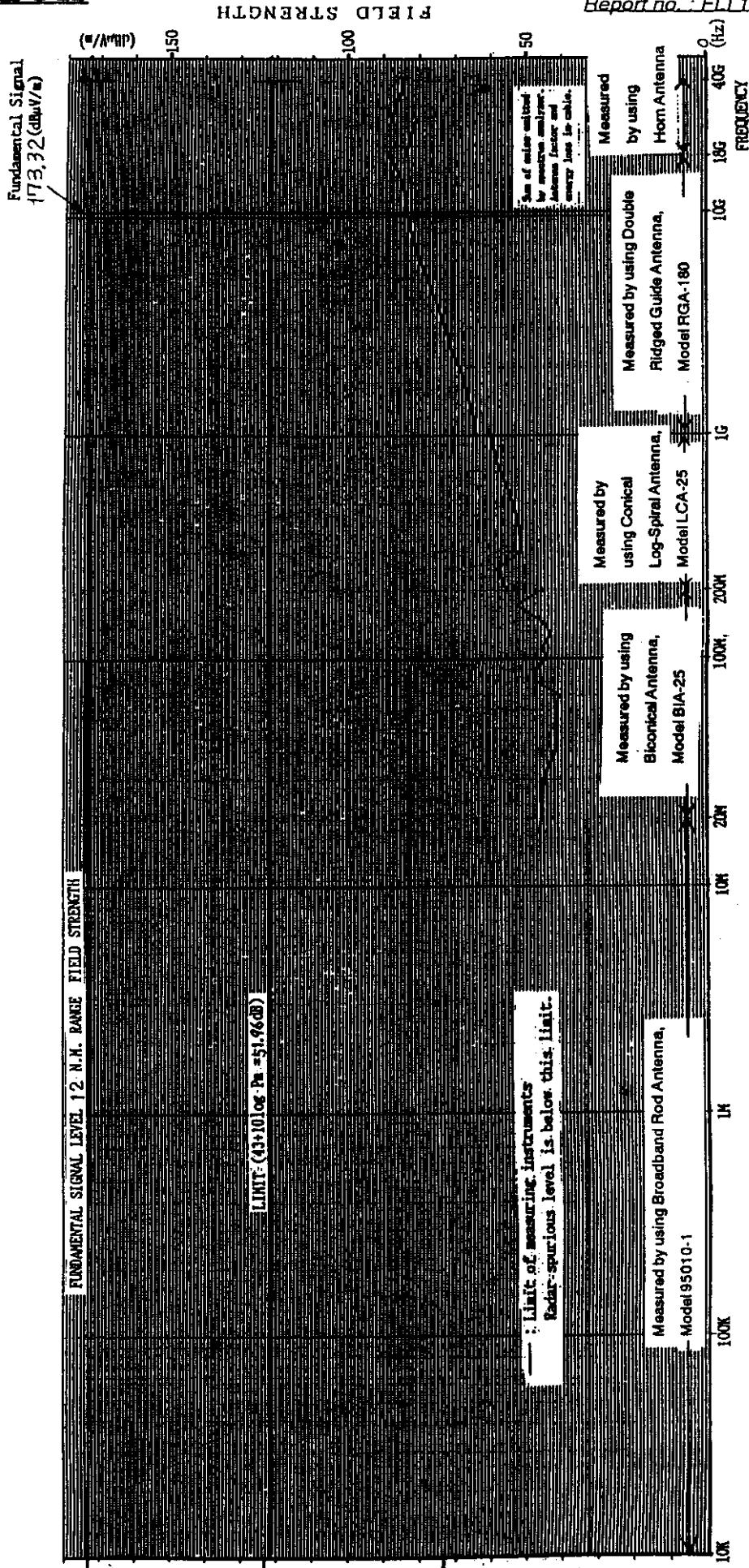

Graph 7-5 Field strength of spurious radiation measured with pick-up antenna (12 nm range) (Middle 3 Pulse)

ATTEN. BELOW FUNDAMENTAL (dB)

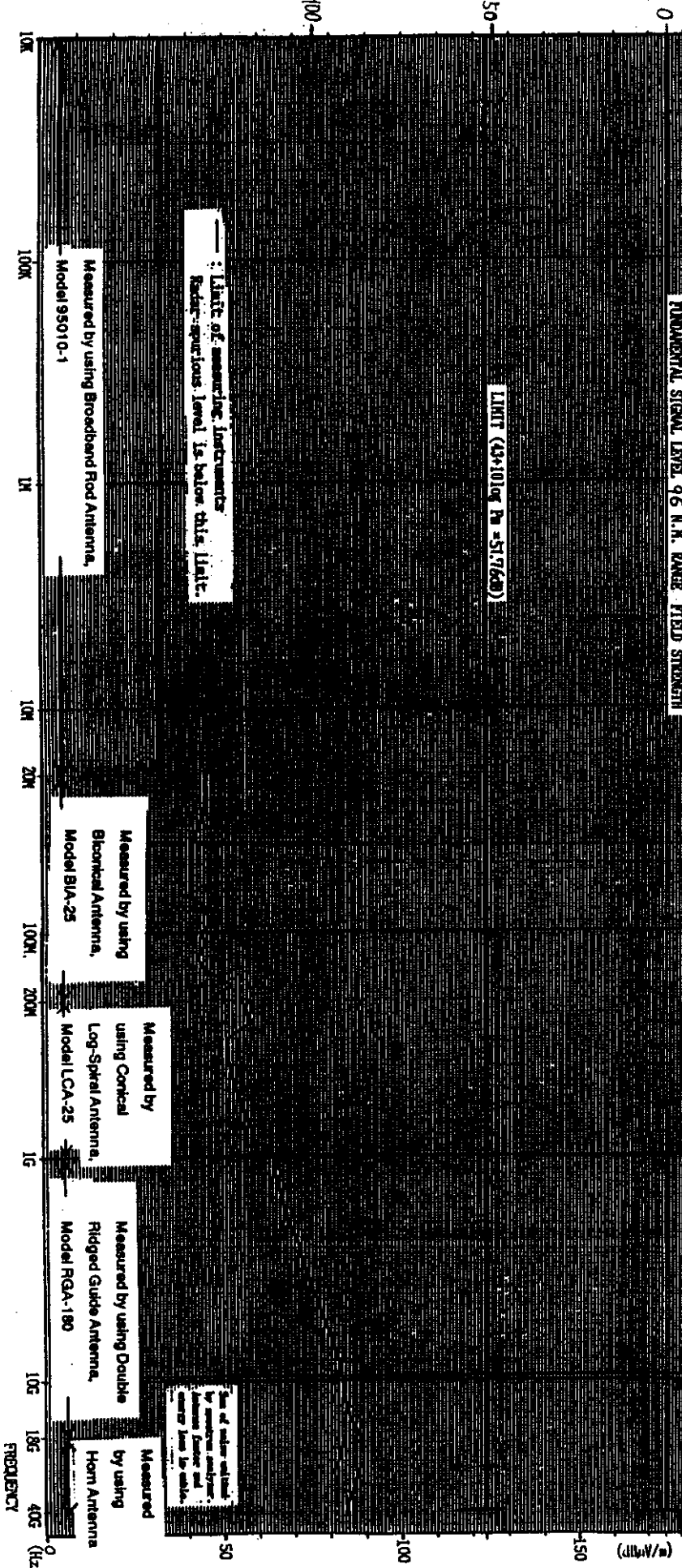

Graph 7-6 Field strength of spurious radiation measured with pick-up antenna (96 nm range) (Long Pulse)

Fundamental Signal
 175.43 (dBW/m²)

ATTACHMENT 3

[TEST DATA FOR 9. SUPPRESSION OF INTERFERENCE ABOARD SHIPS]

1. Harmful Interference to Receiver

(Band : 14 kHz - 490 kHz)

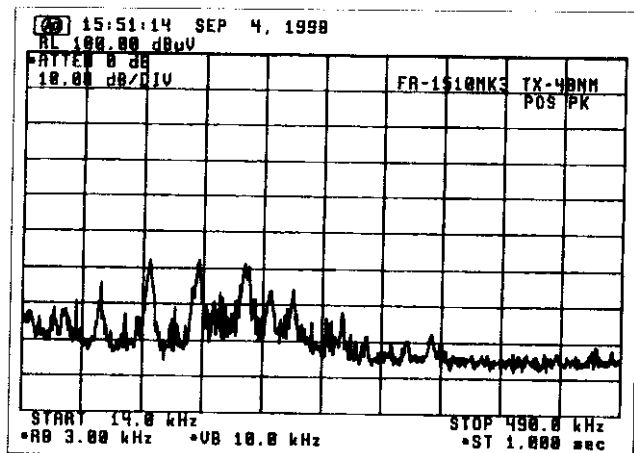
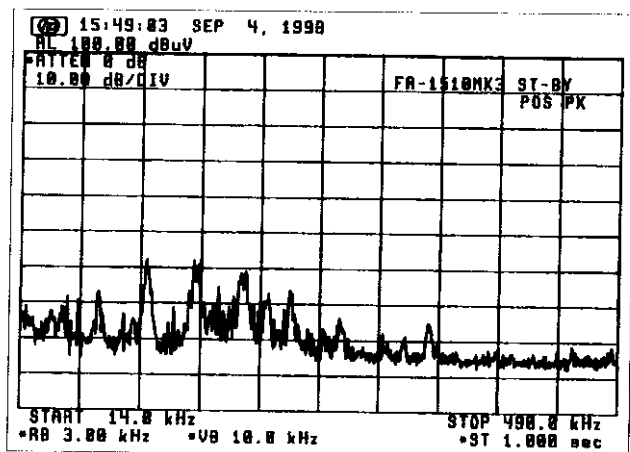
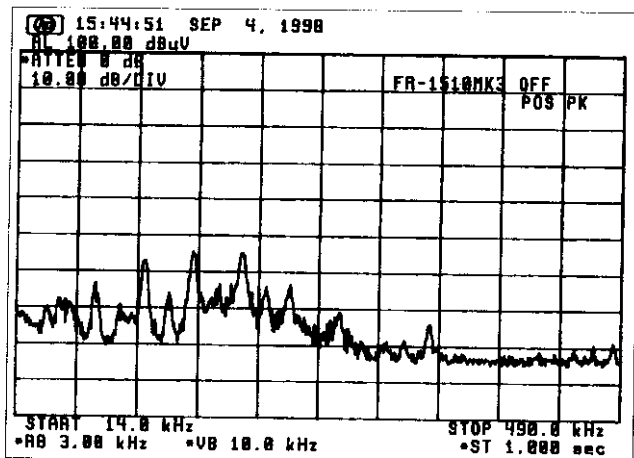

(Band : 490 kHz - 5 MHz)

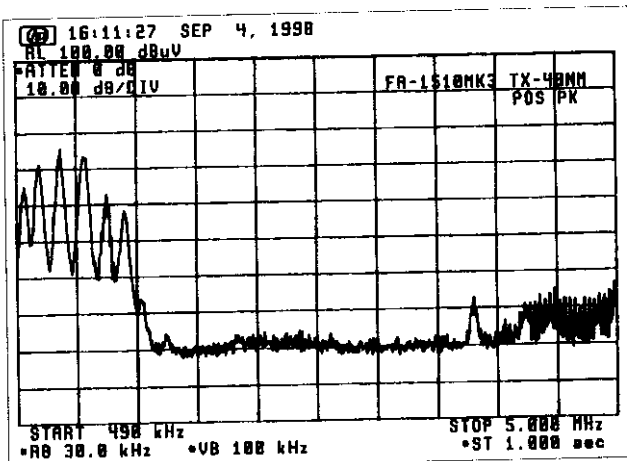
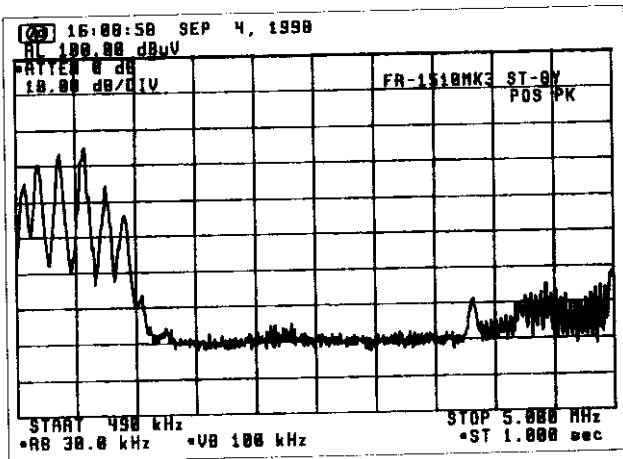
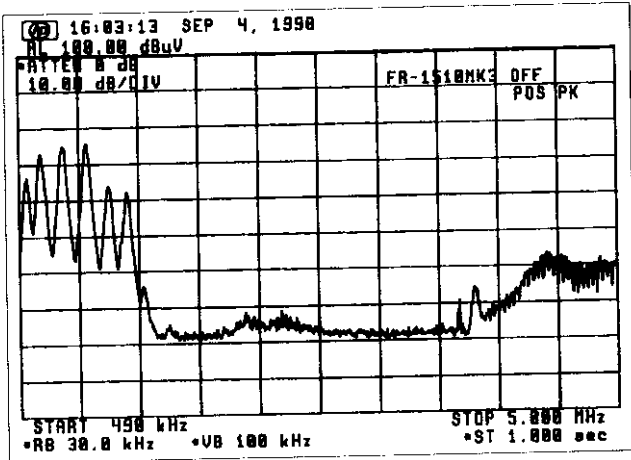

(Band : 5 MHz - 10 MHz)

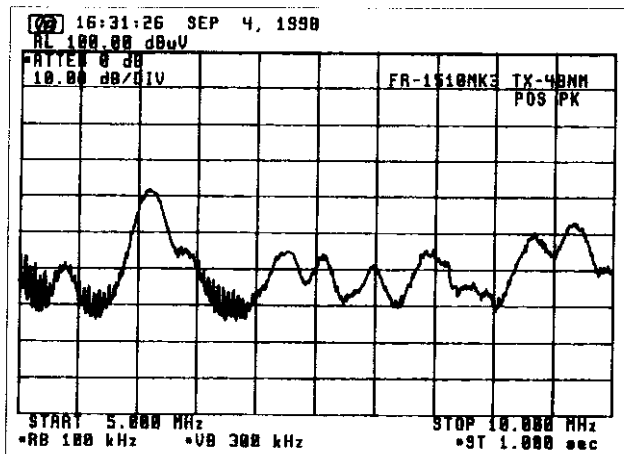
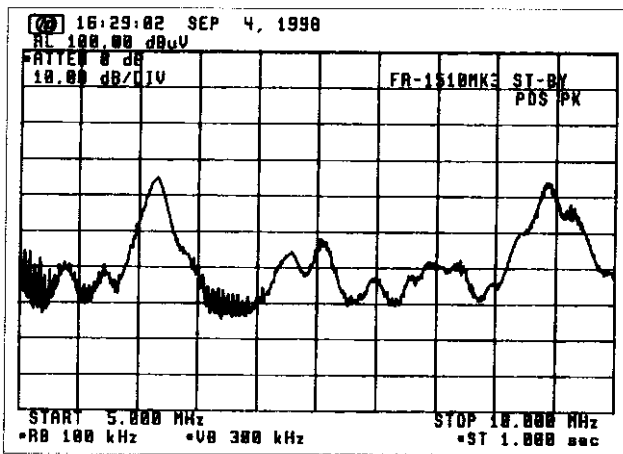
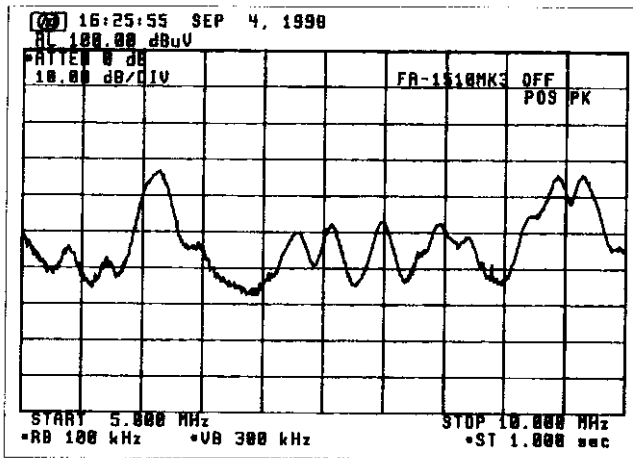

(Band : 10 MHz - 30 MHz)

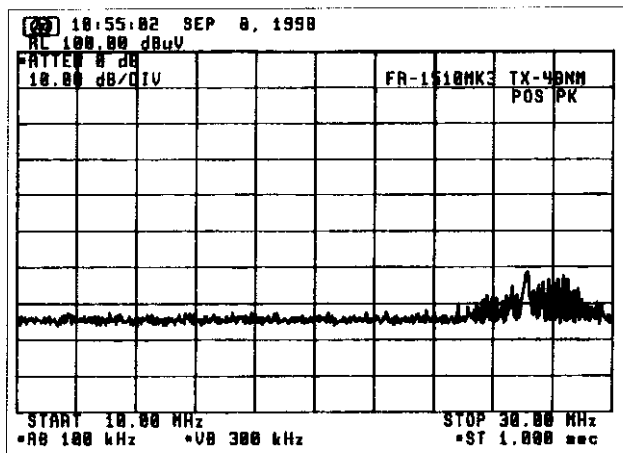
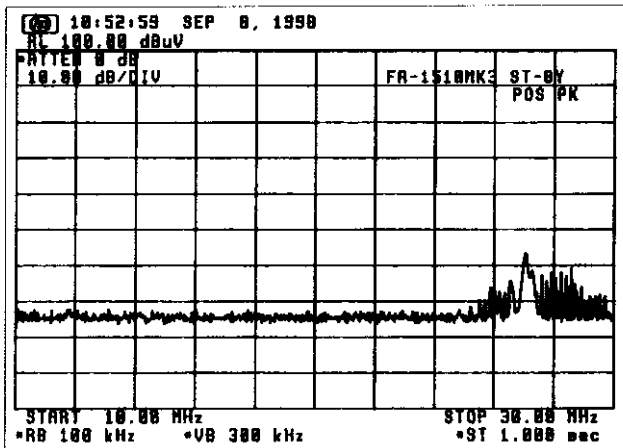
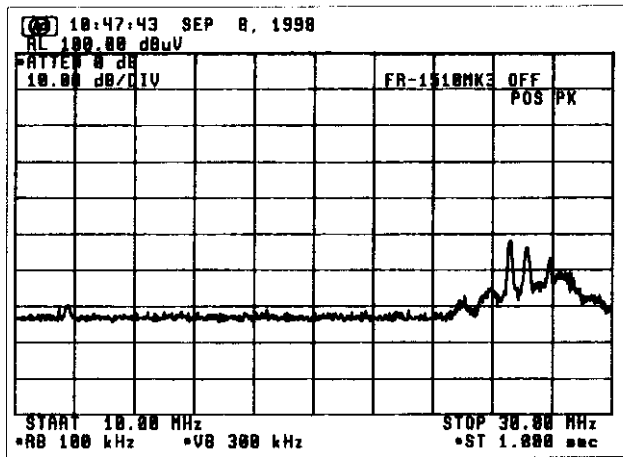

(Band : 30 MHz - 100 MHz)

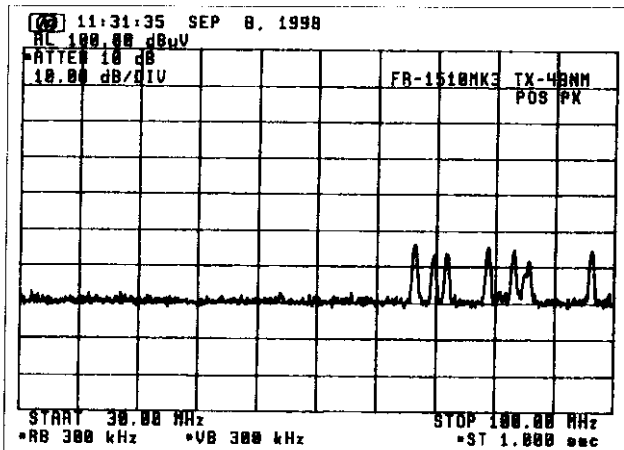
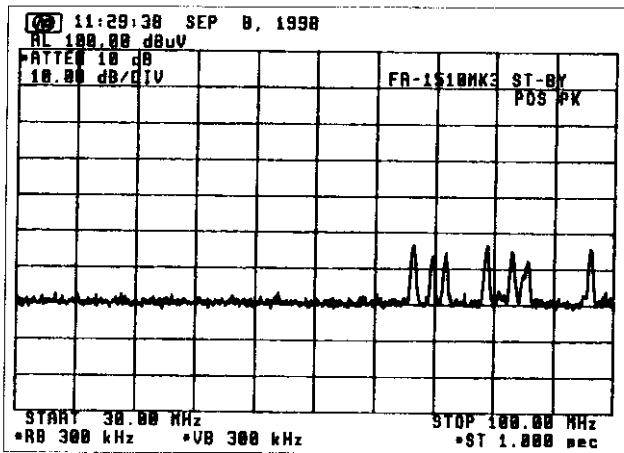
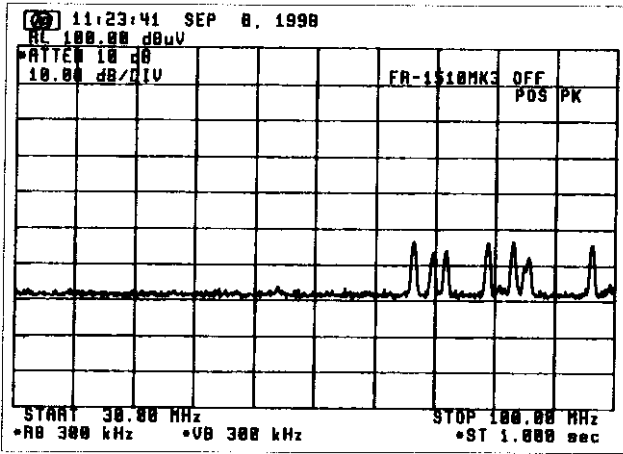

(Band : 100 MHz - 300 MHz)

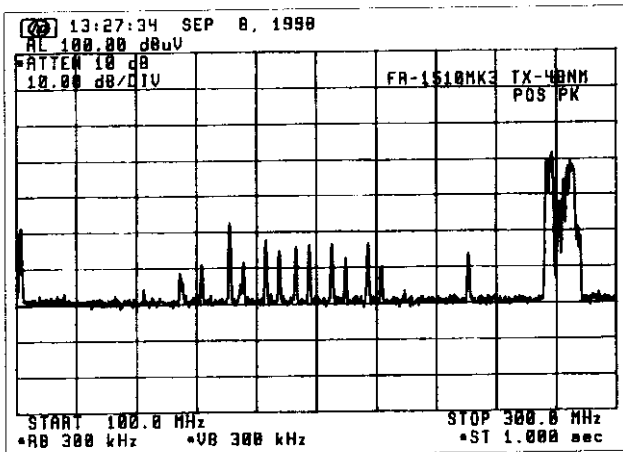
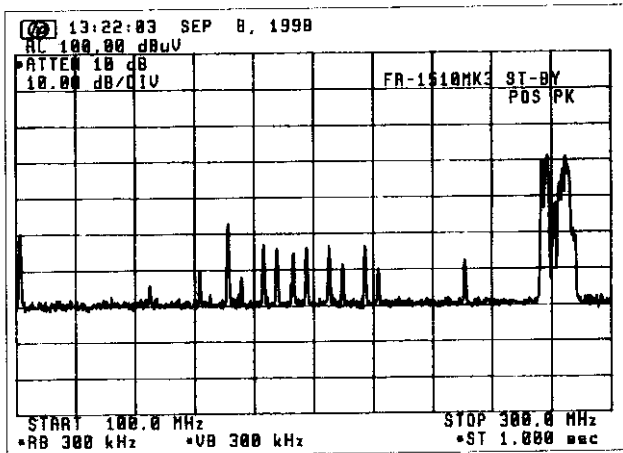
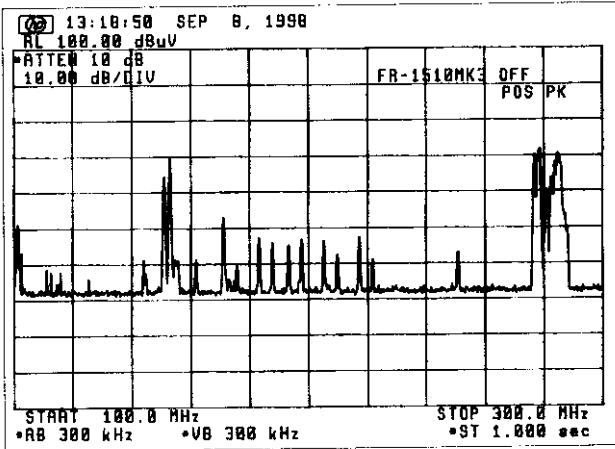

(Band : 300 MHz - 1 GHz)

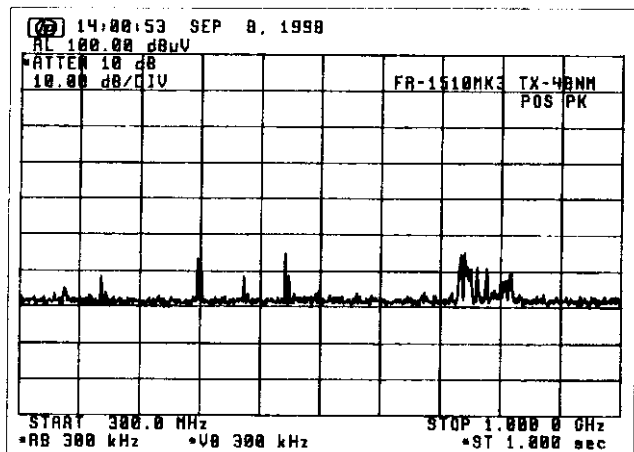
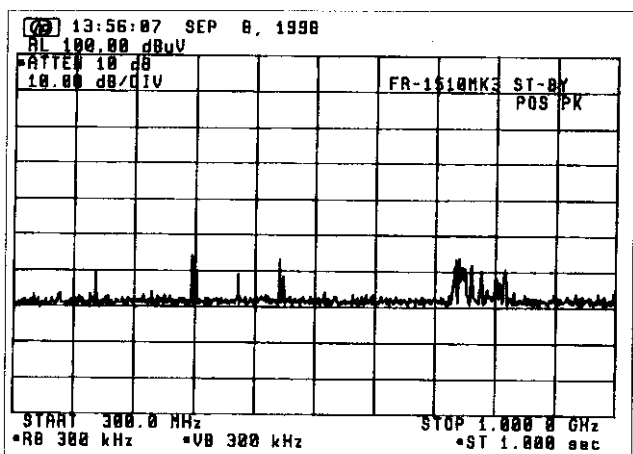
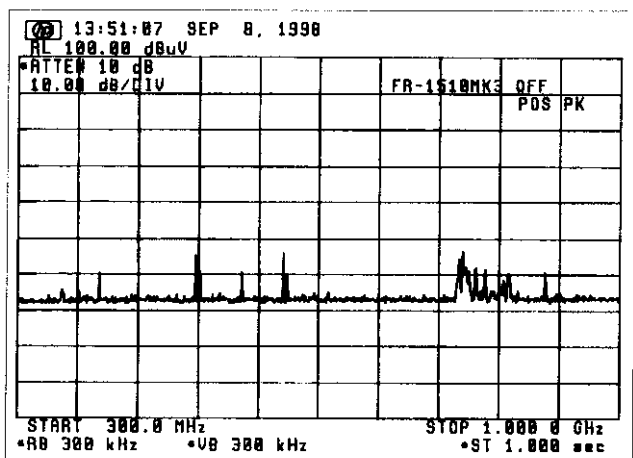

2. Electromagnetic Field

(Band : 14 kHz - 490 kHz, Limit at 1 nm = $0.1 \mu\text{V/m} = -20 \text{ dB}\mu\text{V/m}$)

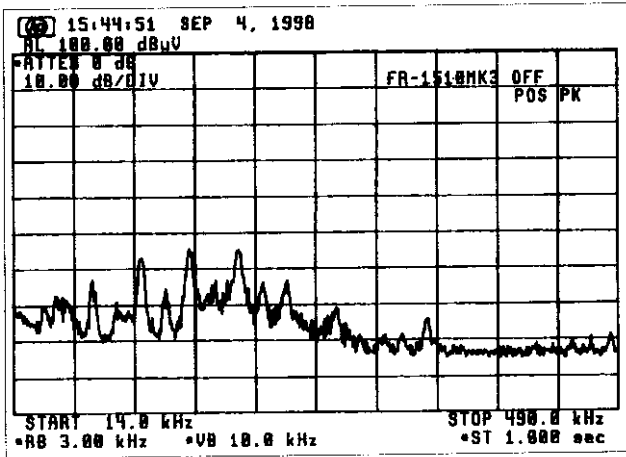

-26 dB μ V/m

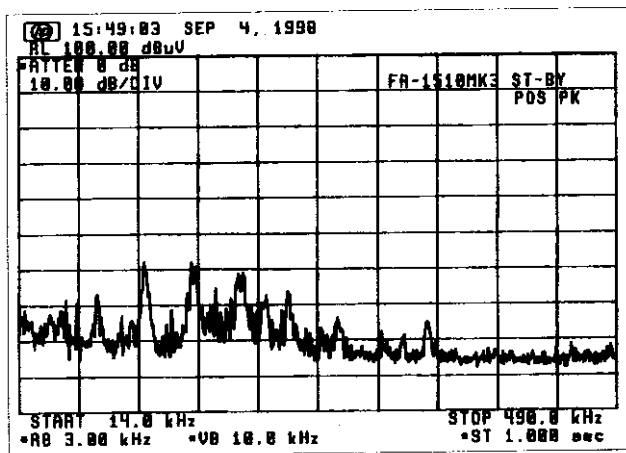

-26 dB μ V/m

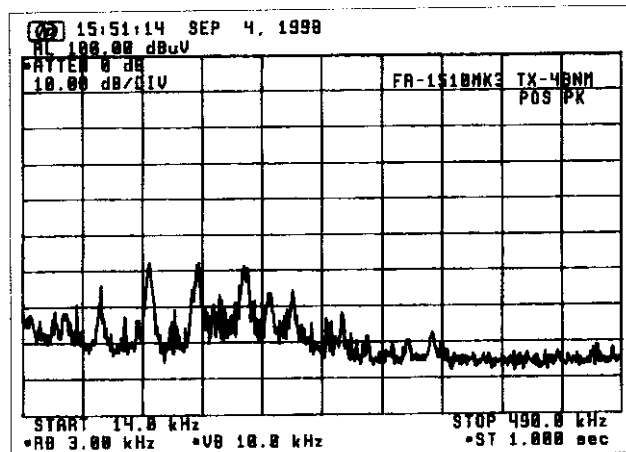

-26 dB μ V/m

(Band : 490 kHz - 5 MHz, Limit at 1 nm = 0.1 μ V/m = -20 dB μ V/m)

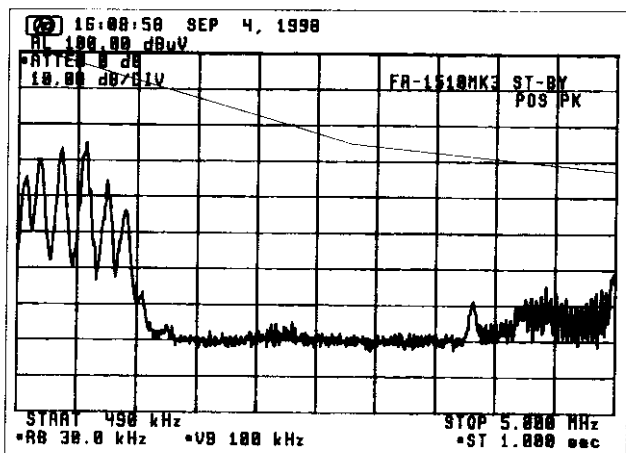
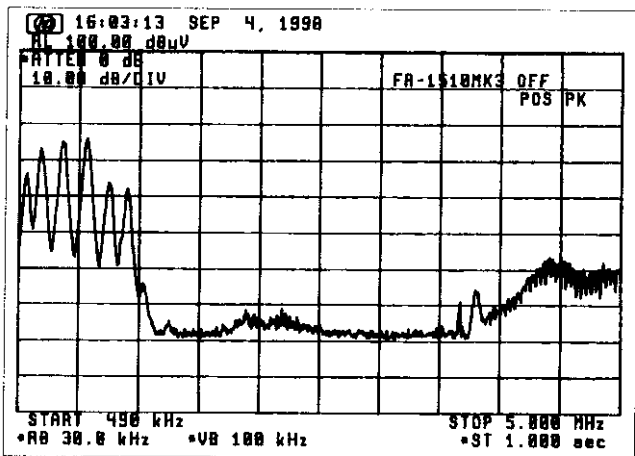

Ref. level (dB μ V/m)
 = 126 - 100 = 26 (at 0.5 MHz)
 = 100 - 96 = 4 (at 3 MHz)
 = 100 - 88 = 12 (at 5 MHz)

-20 dB μ V/m limit line

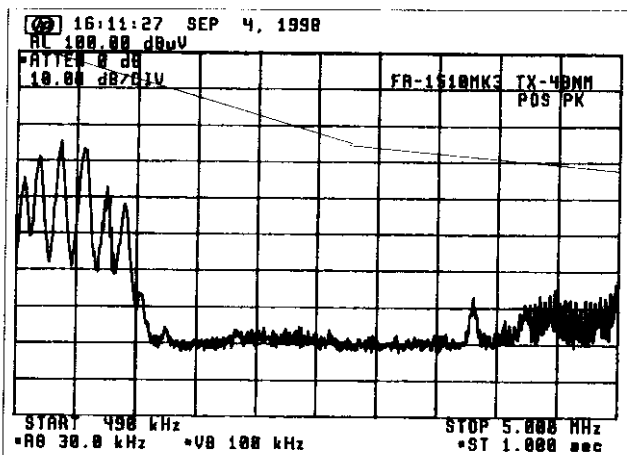

Ref. level (dB μ V/m)
 = 126 - 100 = 26 (at 0.5 MHz)
 = 100 - 96 = 4 (at 3 MHz)
 = 100 - 88 = 12 (at 5 MHz)

-20 dB μ V/m limit line

(Band : 5 MHz - 10 MHz, Limit at 1 nm = 0.1 μ V/m = -20 dB μ V/m)

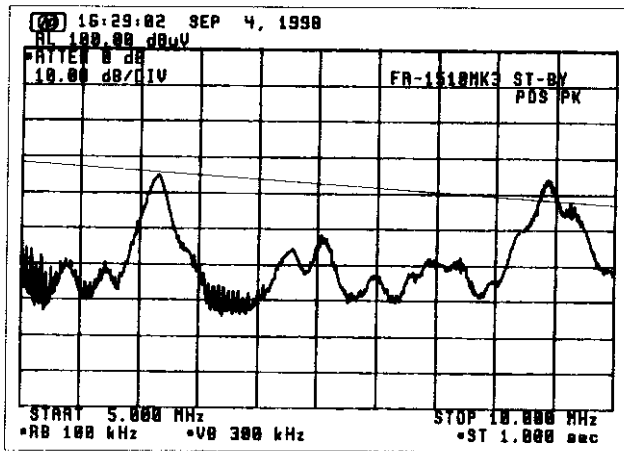
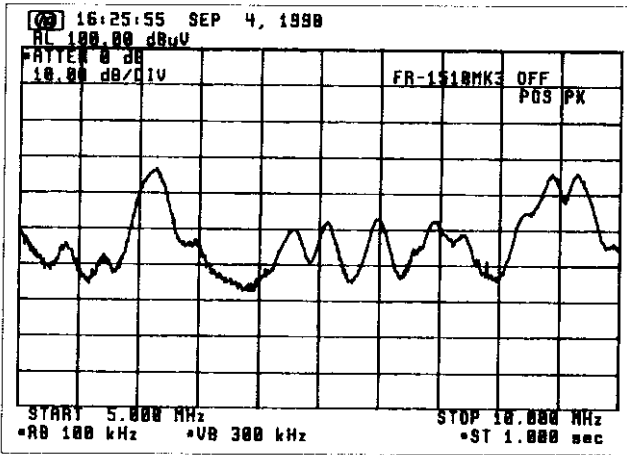

Ref. level (dB μ V/m)
 = 100 - 88 = 12 (at 5 MHz)
 = 100 - 83 = 17 (at 7 MHz)
 = 100 - 78 = 22 (at 10 MHz)

-20 dB μ V/m limit line

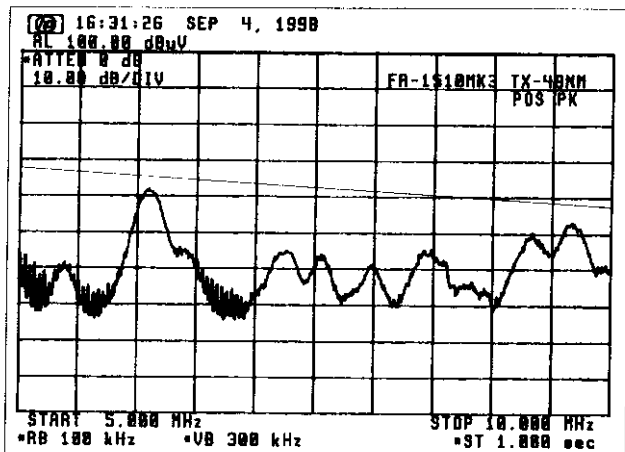

Ref. level (dB μ V/m)
 = 100 - 88 = 12 (at 5 MHz)
 = 100 - 83 = 17 (at 7 MHz)
 = 100 - 78 = 22 (at 10 MHz)

-20 dB μ V/m limit line

(Band : 10 MHz - 30 MHz, Limit at 1 nm = 0.1 $\mu\text{V}/\text{m}$ = -20 $\text{dB}\mu\text{V}/\text{m}$)

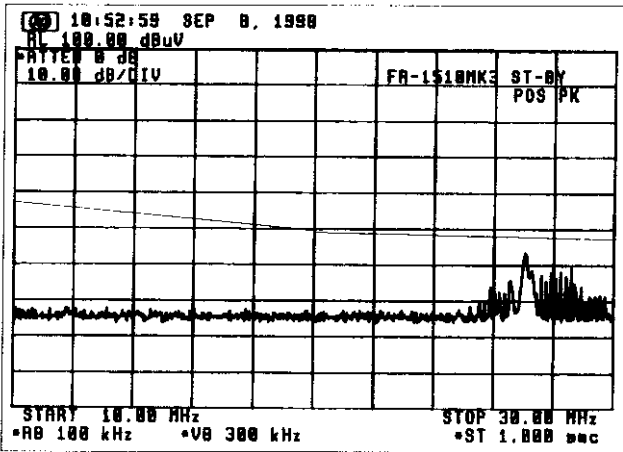
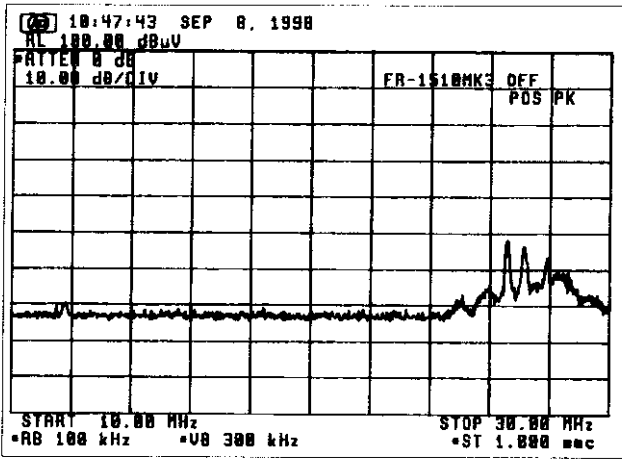

Ref. level ($\text{dB}\mu\text{V}/\text{m}$)
 = 100 - 78 = 22 (at 10 MHz)
 = 100 - 70 = 30 (at 20 MHz)
 = 100 - 67 = 33 (at 30 MHz)

-20 $\text{dB}\mu\text{V}/\text{m}$ limit line

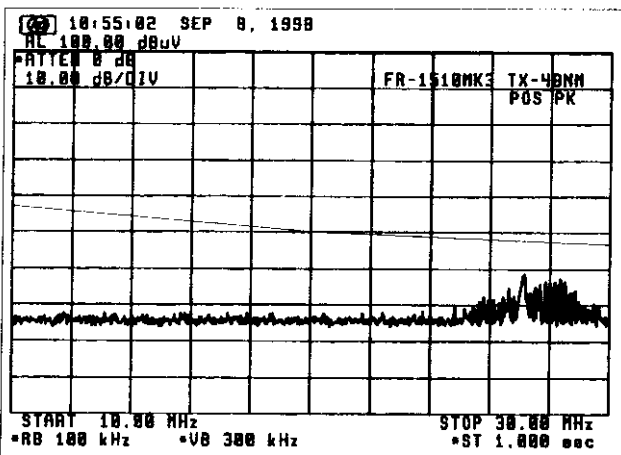

Ref. level ($\text{dB}\mu\text{V}/\text{m}$)
 = 100 - 78 = 22 (at 10 MHz)
 = 100 - 70 = 30 (at 20 MHz)
 = 100 - 67 = 33 (at 30 MHz)

-20 $\text{dB}\mu\text{V}/\text{m}$ limit line

(Band : 30 MHz - 100 MHz, Limit at 1 nm = 0.1 μ V/m = -10.5 dB μ V/m)

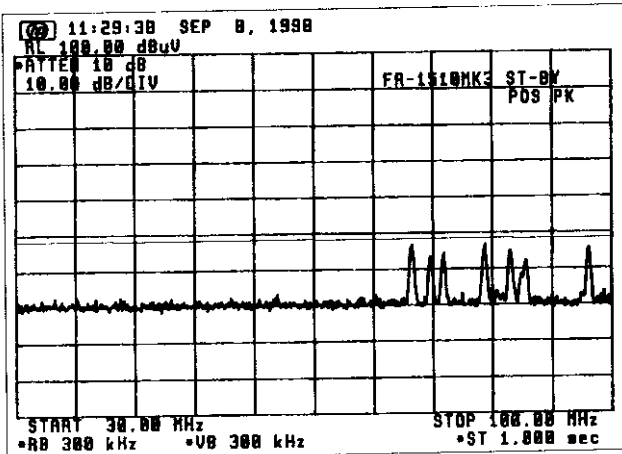
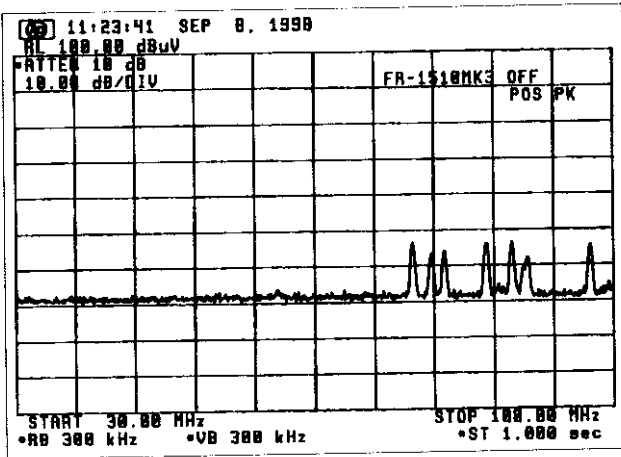

Ref. level (dB μ V/m)
 = 100 - 61 = 39

- 10.5 dB μ V/m limit line

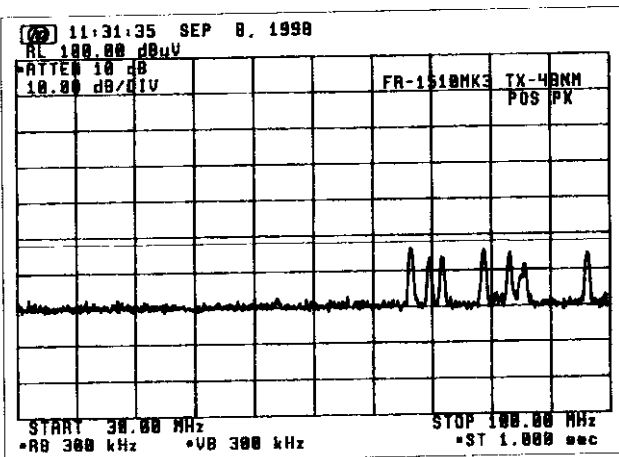

Ref. level (dB μ V/m)
 = 100 - 61 = 39

- 10.5 dB μ V/m limit line

(Band : 100 MHz - 300 MHz, Limit at 1 nm = 0.1 $\mu\text{V}/\text{m}$ = -0 dB $\mu\text{V}/\text{m}$)

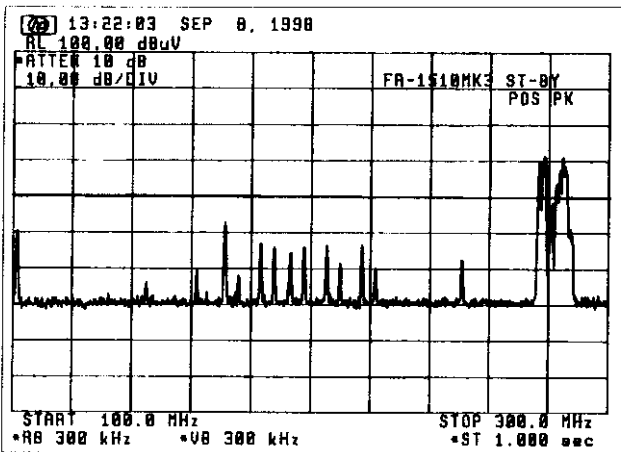
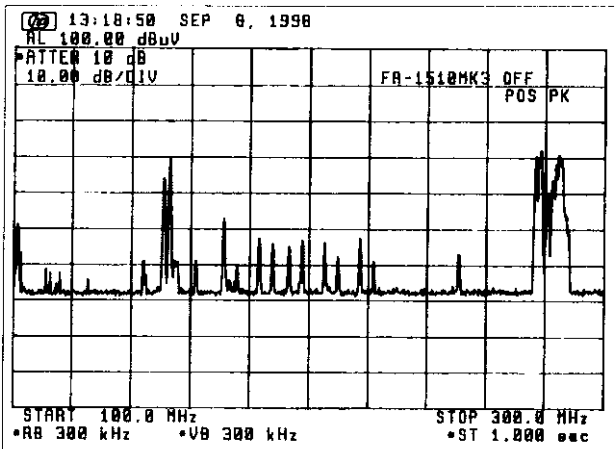

Ref. level (dB $\mu\text{V}/\text{m}$)
= 100 - 60 = 40

0 dB $\mu\text{V}/\text{m}$ limit line

All components above the limit
are from external noise or
signals, not from RADAR.

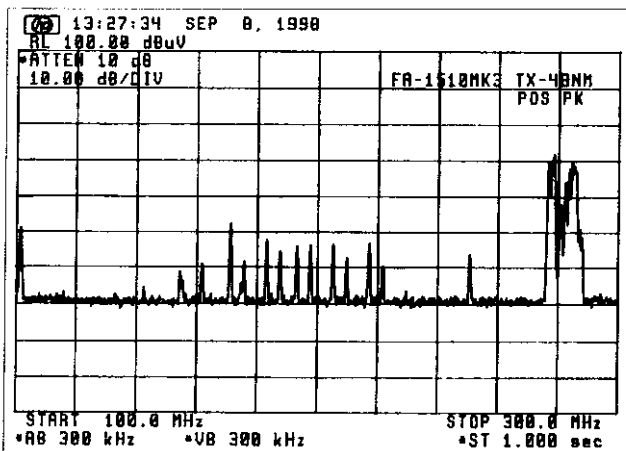

Ref. level (dB $\mu\text{V}/\text{m}$)
= 100 - 60 = 40

0 dB $\mu\text{V}/\text{m}$ limit line

All components above the limit
are from external noise or
signals, not from RADAR.

(Band : 300 MHz - 1 GHz, Limit at 1 nm = 3 μ V/m = -9.5 dB μ V/m)

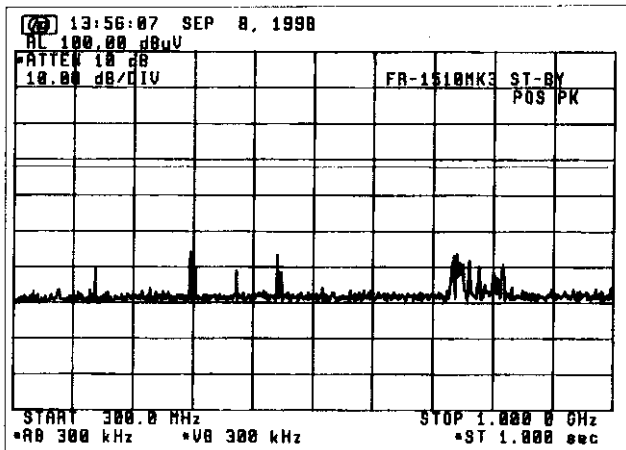
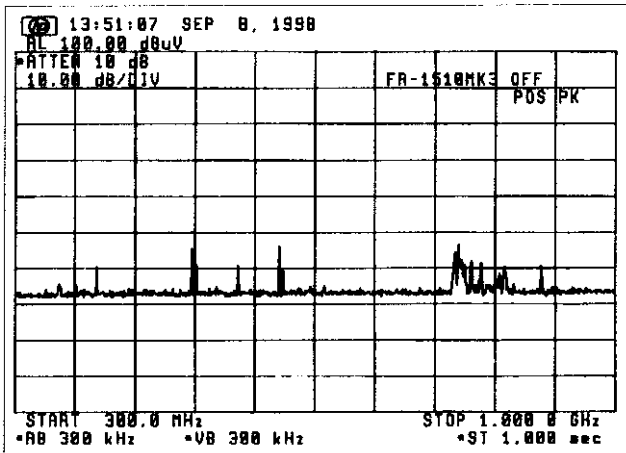

Ref. level (dB μ V/m)
= 100 - 59.5 = 40.5

9.5 dB μ V/m limit line

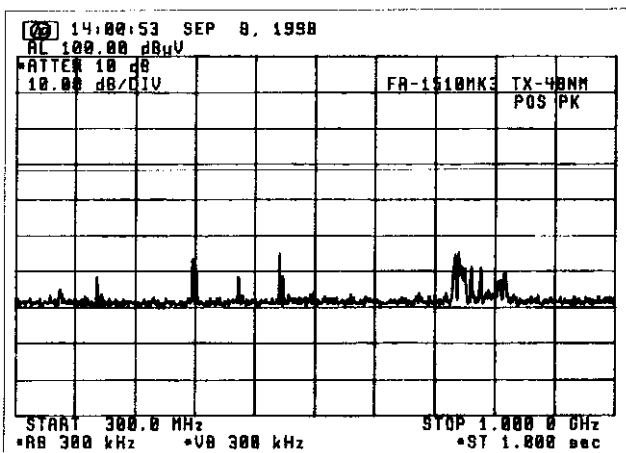

Ref. level (dB μ V/m)
= 100 - 59.5 = 40.5

9.5 dB μ V/m limit line

3. Power Input to an Artificial Antenna

(Band : 14 kHz - 490 kHz, Limit at 2 m = -81 dBm)

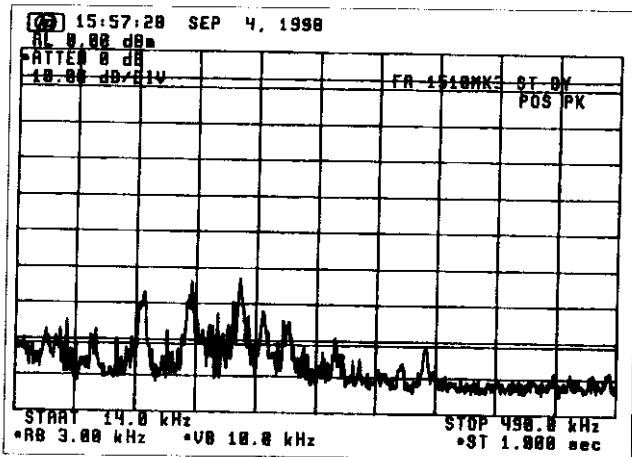
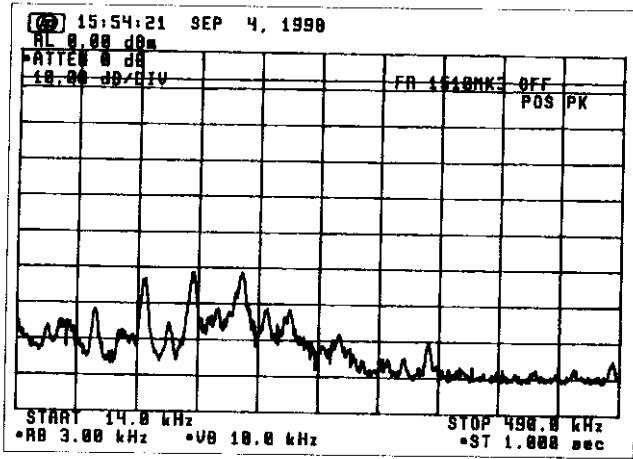

-81 dBm limit line

All components above the limit are from external noise or signals, not from RADAR.

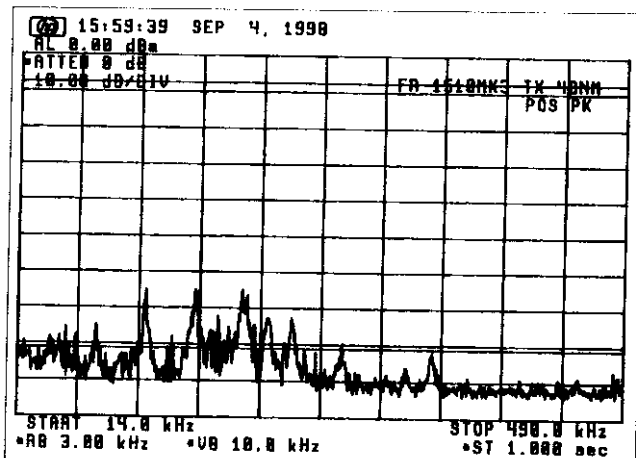

-81 dBm limit line

All components above the limit are from external noise or signals, not from RADAR.

(Band : 490 kHz - 5 MHz, Limit at 2 m = -81 dBm)

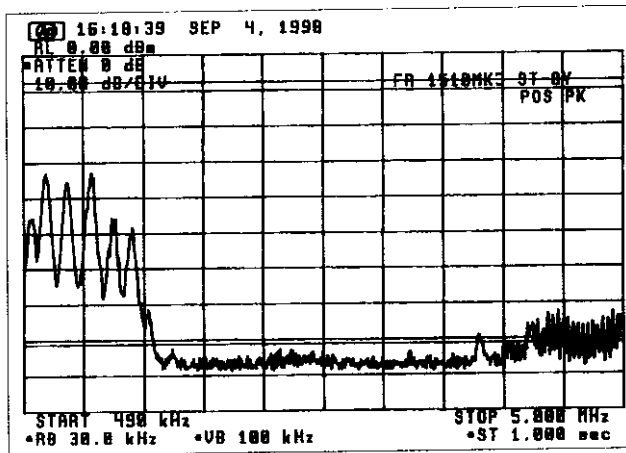
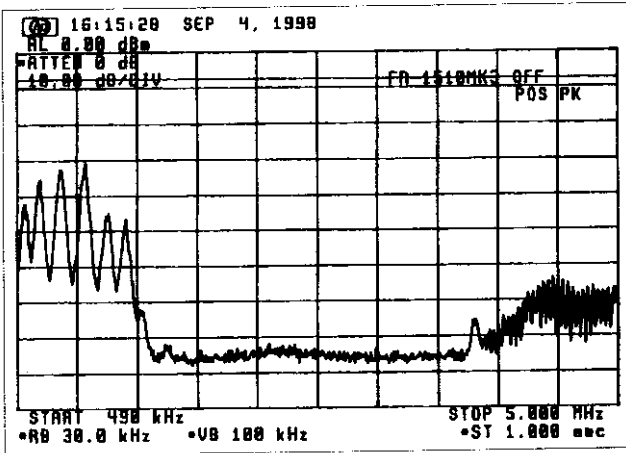

-81 dBm limit line

All components above the limit are from external noise or signals, not from RADAR.

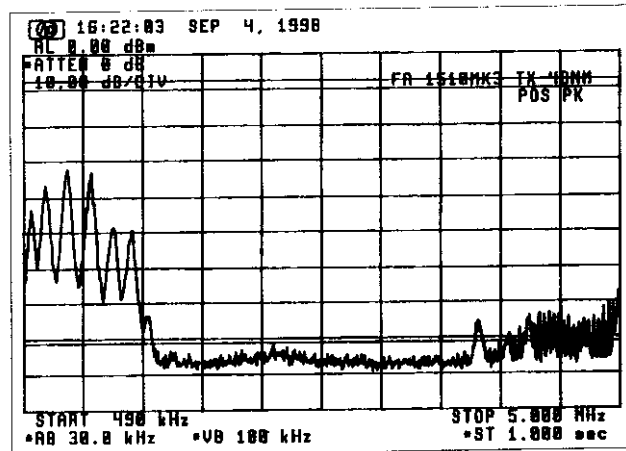

-81 dBm limit line

All components above the limit are from external noise or signals, not from RADAR.

(Band : 5 MHz - 10 MHz, Limit at 2 m = -81 dBm)

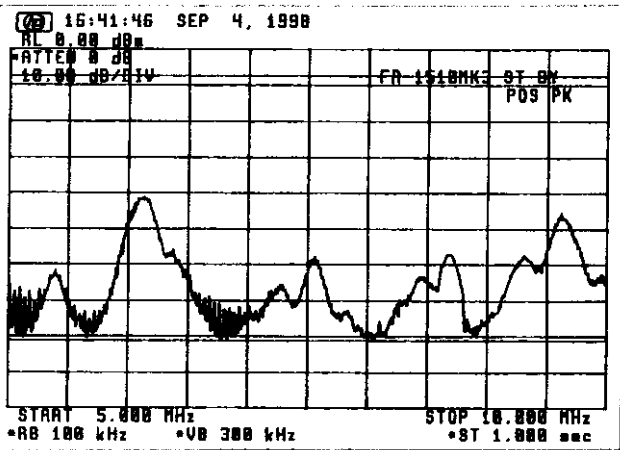
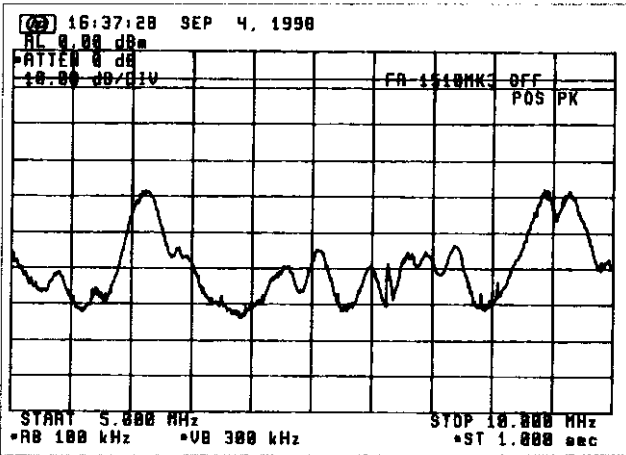

-81 dBm limit line

All components above the limit are from external noise or signals, not from RADAR.

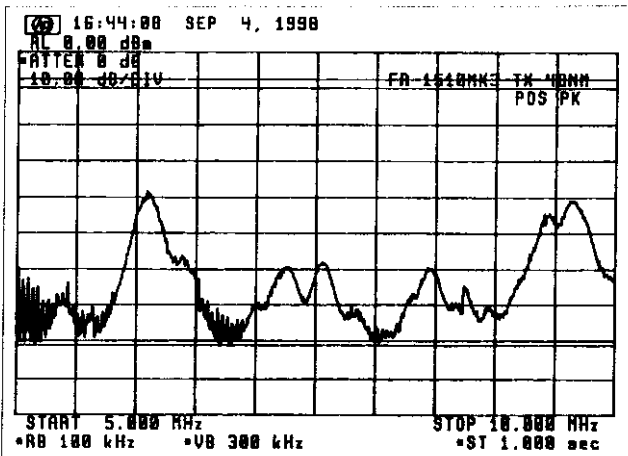

-81 dBm limit line

All components above the limit are from external noise or signals, not from RADAR.

(Band : 10 MHz - 30 MHz, Limit at 2 m = -81 dBm)

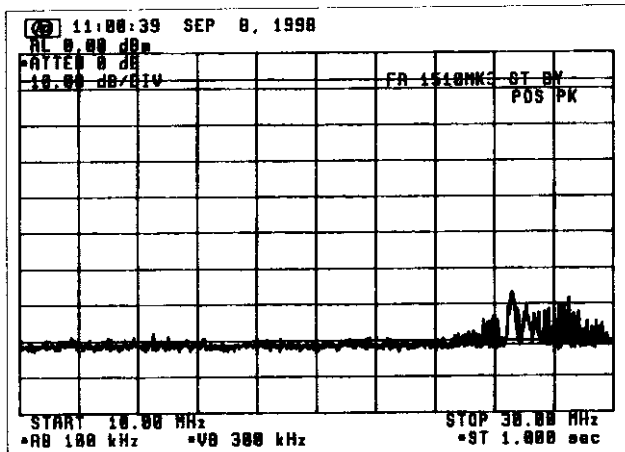
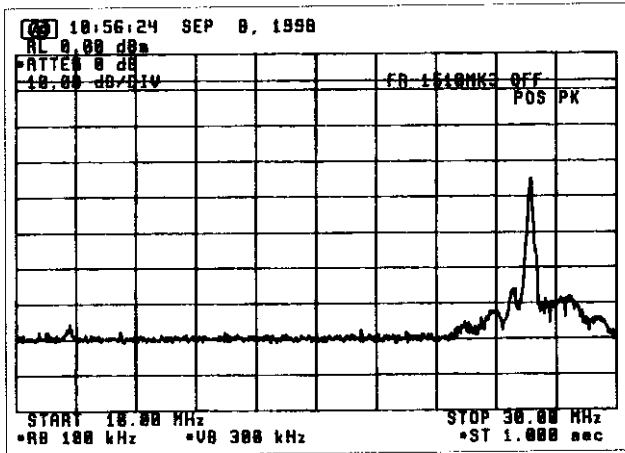

-81 dBm limit line

All components above the limit are from external noise or signals, not from RADAR.

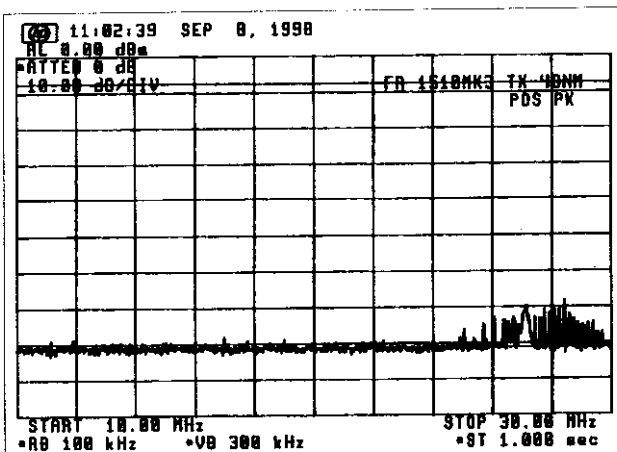

-81 dBm limit line

All components above the limit are from external noise or signals, not from RADAR.

(Band : 30 MHz - 100 MHz, Limit at 2 m = -71 dBm)

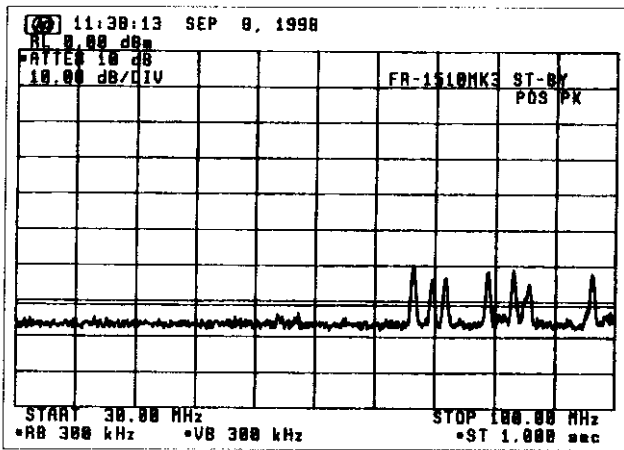
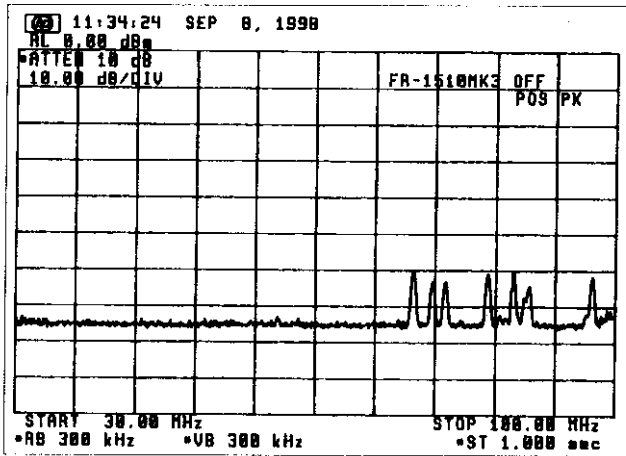

-71 dBm limit line

All components above the limit are from external noise or signals, not from RADAR.

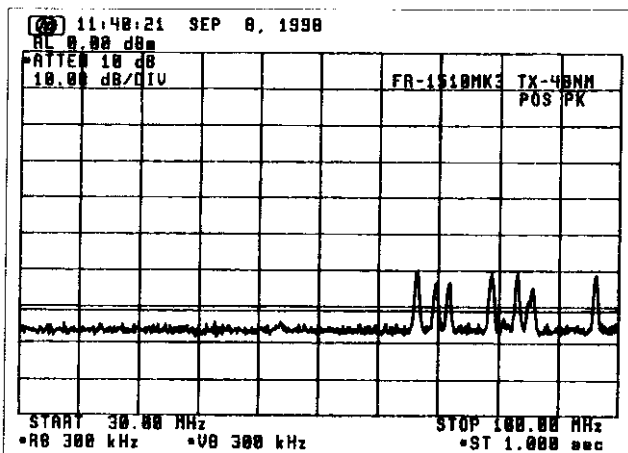

-71 dBm limit line

All components above the limit are from external noise or signals, not from RADAR.

(Band : 100 MHz - 300 MHz, Limit at 2 m = -61 dBm)

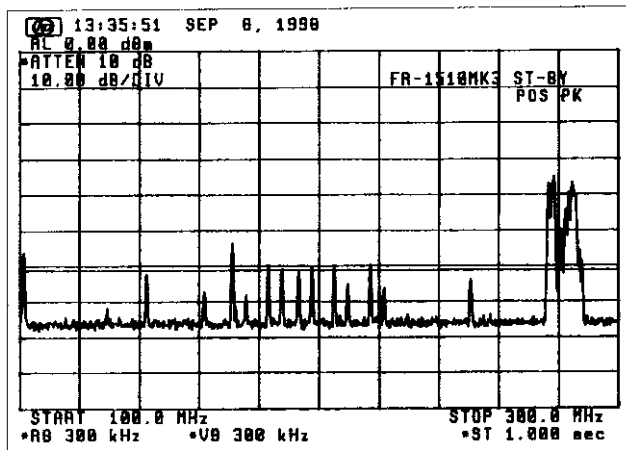
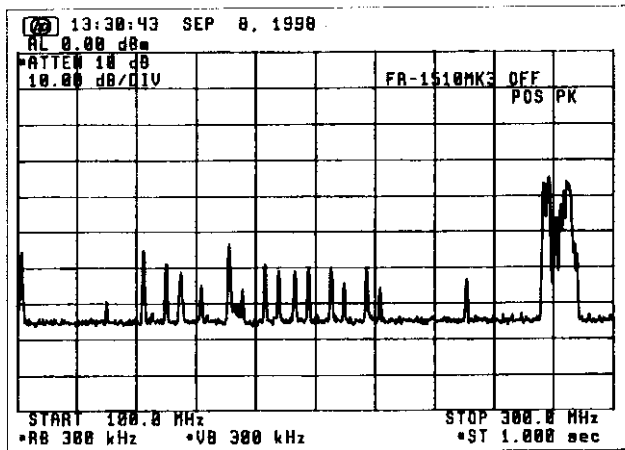

-61 dBm limit line

All components above the limit
are from external noise or
signals, not from RADAR.

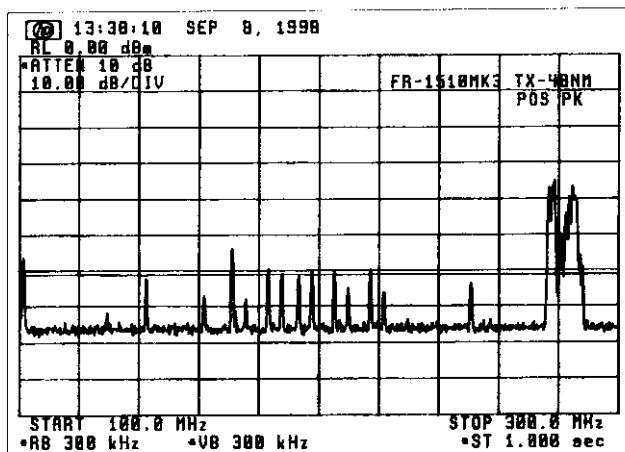

-61 dBm limit line

All components above the limit
are from external noise or
signals, not from RADAR.

(Band : 300 MHz - 1 GHz, Limit at 2 m = -51 dBm)

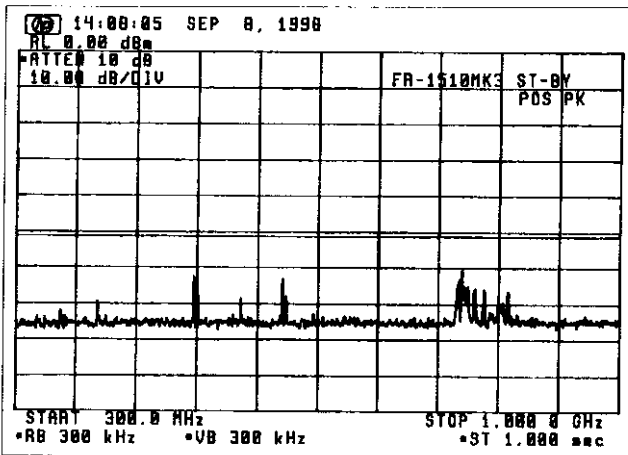
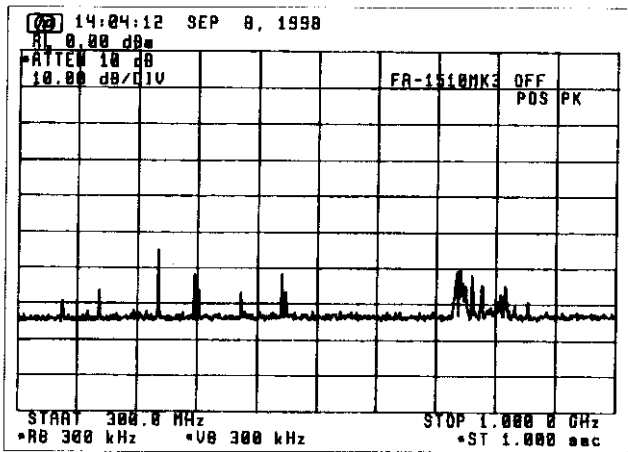

-51 dBm limit line

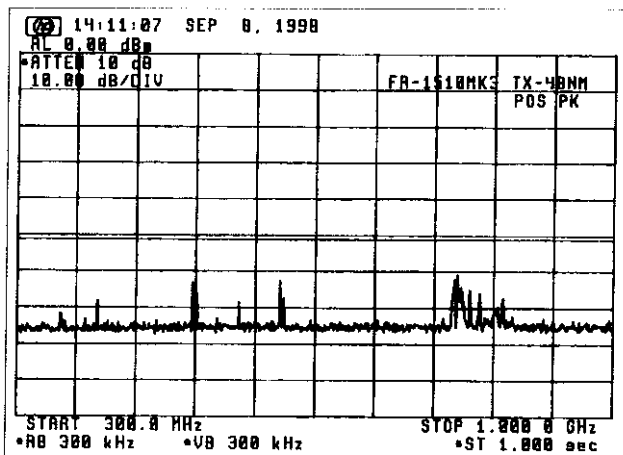

-51 dBm limit line



ATTACHMENT 4 [List of Test/Measuring Equipment]**3. RF Power Output**

<u>Model</u>	<u>Type</u>	<u>Serial no.</u>	<u>Mfr.</u>
Spectrum Analyzer	71210C	2927A02847	HP
Oscilloscope	TDS680B	B030202	Tektronix
Directional Coupler	----	R94471	Shimada
Directional Coupler	5D364S	R05762	Shimada
Voltage Divider	P6015	----	Tektronix
Current Transformer	2100	----	Pearson Electronics
Power Meter	436A	2410A19137	HP
Power Sensor	9481A	2349A39603	HP
Frequency Counter	TR5824A	41940036	Advantest
Frequency Meter	X532B	1441A00523	HP
Crystal Detector	423B	1822A24214	HP
Step Attenuator	8494B	1510A07310	HP
Step Attenuator	8495B	1350A04754	HP
Dummy Load	----	8411057	Shimada

4. Modulation Characteristics

<u>Model</u>	<u>Type</u>	<u>Serial no.</u>	<u>Mfr.</u>
Oscilloscope	TDS680B	B030202	Tektronix
Step Attenuator	8494B	1510A07310	HP
Step Attenuator	8495B	1350A04754	HP
Crystal Detector	423B	1822A24214	HP
Directional Coupler	5D364S	R94471	Shimada
Dummy Load	-----	8411057	Shimada
Voltage Divider	P6015	----	Tektronix
Spectrum Analyzer	71210C	2927A02847	HP

6. Spurious Emissions at Antenna Terminal

<u>Model</u>	<u>Type</u>	<u>Serial no.</u>	<u>Mfr.</u>
Spectrum Analyzer	71210C	2927A0847	HP
Attenuator (10 dB)	8491B	36122	HP
External Mixer:	11970K	2332A00589	HP
External Mixer:	11970A	2332A01187	HP
Directional Coupler	5D364S	R05762	Shimada
Dummy Load	-----	8411057	Shimada
Notch Filter			
Circulator	MA8L32#8	----	Microwave Associates
Bandpass filter	-----	R9904	Shimada
High Pass Filter	-----	-----	Furuno

7. Field Strength of Spurious Radiation

<u>Model</u>	<u>Type</u>	<u>Serial no.</u>	<u>Mfr.</u>
Broadband Rod Antenna	M 95010-1	0496	Advanced Electronics
Biconical Antenna	BIA-25	2650	Electro Metrics
Conical Log-Spiral Antenna	LCA-25	2886	Electro Metrics
Double Ridged Guide Horn Antenna :RGA-180		----	EMD
Horn Antenna:	----	----	Toshiba
Spectrum Analyzer:	71210C	2927A0287	HP
External Mixer:	11970K	2332A00589	HP
External Mixer:	11970A	2332A01187	HP
Notch Filter			
Circulator	MA8L32#8	----	Microwave Associates
Bandpass filter	-----	R9904	Shimada

8. Frequency Stability

<u>Model</u>	<u>Type</u>	<u>Serial no.</u>	<u>Mfr.</u>
Power Meter:	436A	2410A19137	HP
Power Sensor:	8481A	2349A39603	HP
Frequency Meter:	X532B	1441A00523	HP
Directional Coupler:	5D364S	R9425	Shimada
Dummy Load:	----	8411057	Shimada
Environmental Chamber:	PL-4E	1632712	Tabai Espec

9. Suppression of Interference Aboard Ships

<u>Model</u>	<u>Type</u>	<u>Serial no.</u>	<u>Mfr.</u>
Spectrum Analyzer:	71210C	2927A02847	HP
6 m Whip Antenna	14 k - 10 MHz	----	Furuno
4 m Whip Antenna	10 - 30 MHz	----	Furuno
VHF Whip Antenna	30 - 300 MHz	150M-W2UM	Anten
UHF Whip Antenna	300 - 1000 MHz	----	Anten
RF Vector Impedance Meter:	4815A	2048A03354	HP
Spectrum Analyzer	TR4172	30690116	Advantest
Spectrum Analyzer	8566B	2637A03642	HP

