

TECHNICAL INFORMATION

TEST REPORT ON THE PERFORMANCE OF VHF RADIOTELEPHONE

Brand Name : FURUNO

Type : FM-8800S

Report no.: FLI 12-04-069

Date of issue: November 15, 2004

Furuno Labotech International Co., Ltd.

9-52 Ashihara-cho, Nishinomiya City, Hyogo 662-8580, Japan

Tel: +81-798-63-1094 Fax: +81-798-63-1098

All tests reported in this document were performed in Furuno Labotech International Co., Ltd.
All data herein contained is true and correct to our best knowledge.

Tested by: Katusmi Imamura / Assistant Chief Engineer, Technical Section
Takekazau Yokose / Chief Engineer, Technical Section

Reviewed by: Takekazau Yokose / Chief Engineer, Technical Section

Approved by: Mitsuyoshi Komori / Manager, Technical Section

Date: November 15, 2004
Name: Mitsuyoshi Komori
Manager, Technical Section

Signature:

A handwritten signature in blue ink, appearing to read 'M. Komori', with a large, sweeping flourish extending to the right.

******* CONTENTS *******

1	GENERAL INFORMATION	4
1.1	Specifications	4
1.2	List of Measuring/Test Equipment Used	6
2	IDENTIFICATION OF EQUIPMENT (FCC Rule Part 2.925)	7
3	TEST DATA	8
3.1	RF Power Output	8
3.1.1	RF Power Output (FCC Rules Part 80.215 & 2.1046)	8
3.1.2	Output Power Variation	9
3.2	Modulation Characteristics (FCC Rule Part 2.1047)	10
3.2.1	Audio Frequency Response (FCC Rules Part 2.987 (a) (b) & 80.213)	10
3.2.2	Modulation Limiting FCC Rule Part 2.1047)	12
3.3	Occupied Bandwidth (FCC Rule Part 2.1049 & 80.211)	14
3.4	Spurious Emissions at Antenna Terminal (FCC Rule Part 2.1051 & 80.211)	20
3.5	Field Strength of Spurious Radiation (FCC Rule Part 2.1053)	28
3.6	Frequency Stability (FCC Rule Part 2.1055)	34
3.7	Maximum Usable Sensitivity for the Receiver (FCC Rule Part 80.874)	35
4	PHOTOGRAPHS TO REVEAL EQUIPMENT CONSTRUCTION AND LAYOUT (FCC Rule Part 2.1033)	36
5	DESCRIPTION OF CIRCUITRY AND DEVICES (FCC Rule Part 2.1033)	37
5.1	Function of Each Semiconductor or Active Device	37
5.2	Description of the circuits employed for suppression of spurious radiation, for limiting or shaping the control pulse, and for limiting or controlling power	40
6	OPERATOR'S MANUAL INCLU. CIRCUIT DIAGRAMS (FCC Rule Part 2.1033)	53

1 GENERAL INFORMATION**1.1 Specifications****1.1.1 Outline**

(a) Manufacturer: Furuno Electric Co., Ltd.,
Aihara-cho 9-52, Nishinomiya-city,
662-8580 Japan

(b) Model: FM-8800S (for Simplex operation with DSC Class A)

	Type	Serial Number
Transceiver unit	FM-8800S	5345-0001
Handset	HS-2003	0001
Remote Station	RB-8810	0001
Handset	HS-8800	0001
Remote Station	RB-8800	0001
Handset	HS-8800	0001
Junction Box	IF-8810	0001
DMC Interface	IF-8820	0001

(c) Number of Channel: INTL: 57,
USA: 55,
Weather: 10,
Canada: 55,
Private: 20

(d) Frequency Stability: Within ± 1.5 kHz

(e) Communication System: FM-8800S: Simplex/Semi-duplex

(f) Class of Emission: 16K0G3E (Voice)
16K0G2B (DSC)

(f) Antenna Impedance: 50 ohms

1.1.2 Transmitter functions

(a) Frequency range:

Simplex	155.000 to 161.475 MHz
Semi-duplex	155.000 to 161.475 MHz

(b) Output Power: 25 W (1 W at power reduction)

(c) Frequency Deviation: ≤ 5 kHz

1.1.3 DSC functions

- (a) Protocol: ITU-R Rec. M.541-8, M.493-10 (Class A) and M.689-2
- (b) Baud Rate: 1200 baud \pm 30 ppm max.
- (c) Modulation: AFSK
- (d) Frequency shift: 1700 \pm 400 Hz
Mark: 1300 Hz
Space: 2100 Hz

1.1.4 CH70 Watch Receiver functions

- (a) Receiving Frequency: 156.525 MHz
- (b) Sensitivity: Symbol error rate (SER): Less than 1% (at 0 dB μ V)
- (c) Conducted Spurious Emission: Less than 2 nW

1.1.5 Power Requirements

- (a) Power supply: 24 VDC
- (b) Power consumption:

mode	
Waiting	0.5 A
Receive	1.6 A at 4 W audio output
Transmit	1.6 A at 1 W output, 4.7 A at 25 W output

1.1.6 Digital Interface

IEC 61162-1 (NMEA0183 Ver. 3)
Sentence IN: GGA>RMC>GNS>GLL>ZDA,
Sentence OUT: TLL
Talker: GP>LC>DE>II>IN>EC

1.1.7 Ambient Conditions

- (a) Temperature: -15°C to 55°C
- (b) Relative humidity: 93% (at 40°C)
- (c) Waterproofing (IEC 60529):

Transceiver Unit	Chassis: IPX0 Panel: IPX4
Handset/Hanger	HS-2003: IPX4
Remote Box/Handset	RB-8800: IPX0 HS-8800: IPX2
Junction Box	IF-8810: IPX0
DMC Interface	IF-8820: IPX0

(d) Dimensions & Weight:

	Type	Height (mm)	Width (mm)	Depth (mm)	Weight (kg)
Transceiver unit	FM-8800	142	305	285	5.5
Handset	HS-2003	35	55	200	0.2
Remote Station	RB-8810	57	65	208	0.7
Remote Station	RB-8800	71	140	208	1.2
Junction Box	IF-8810	43	290	150	2.5
DMC Interface	IF-8820	43	290	150	1.2
Handset	HS-8800	35	55	200	0.32

1.2 List of Measuring/Test Equipment Used

No.	Instrument	Type	Serial No.	Manufacture	Calibration Due date
a)	Audio Analyzer	8903A	2407A03630	HP	July 2005
b)	Modulation Analyzer	8901B	2718A01184	HP	July 2005
c)	Signal Generator	8657B	3210U02949	HP	July 2005
d)	Spectrum Analyzer	R3267	121001335	ADVANTEST	December 2004
e)	Frequency Counter	R5362A	13720092	ADVANTEST	July 2005
f)	Resistance Attenuator	RA-920A	1090049	KENWOOD	August 2005
g)	30 dB Attenuator	8498A	04084	HP	September 2005
h)	Multi Meter	E2377A	3651J18669	HP	February 2005
i)	DC Power Supply	GP0060-10		TAKASAGO	
J)	DC Current Meter	201137	83AA0210	YOKOGAWA	February 2005
k)	Signal Generator	8648B	3847M01057	Agilent	August 2005
l)	EMI Test Receiver	ESCS30	826457/021	R/S	December 2004
m)	Halfwave Dipole Antenna	3121C	DB1 1339, DB2-4 1393	Electro Metrics	August 2005

2 IDENTIFICATION OF EQUIPMENT (FCC Rule Part 2.925)

The following nameplates are permanently fixed on the equipment.

FCC ID: ADB9ZWFM8800S
Material of nameplate: Polyester film (t = 100 µm)

ON TRANSCEIVER UNIT:

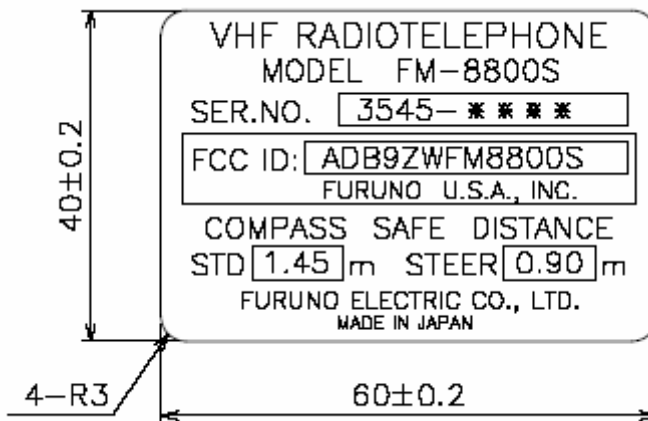

(mm)

3 TEST DATA

3.1 RF Power Output

3.1.1 RF Power Output (FCC Rules Part 80.215 & 2.1046)

3.1.1.1 Method of Measurement

- (a) The DC voltages applied to and DC currents into the final RF output module of the EUT (Equipment Under Test) will be measured.
- (b) Carrier power will be measured at the EUT RF output terminal with 50 Ω load attached for both HI and LO Power positions. See Fig. 3.1.1 below.
- (c) Power Supply Voltages applied to the EUT will be set to 24 VDC ±15% respectively and then tested.
- (d) TX frequencies will be set to CH16 (156.800 MHz), CH28 (157.400 MHz) and CH60 (156.025 MHz) respectively.

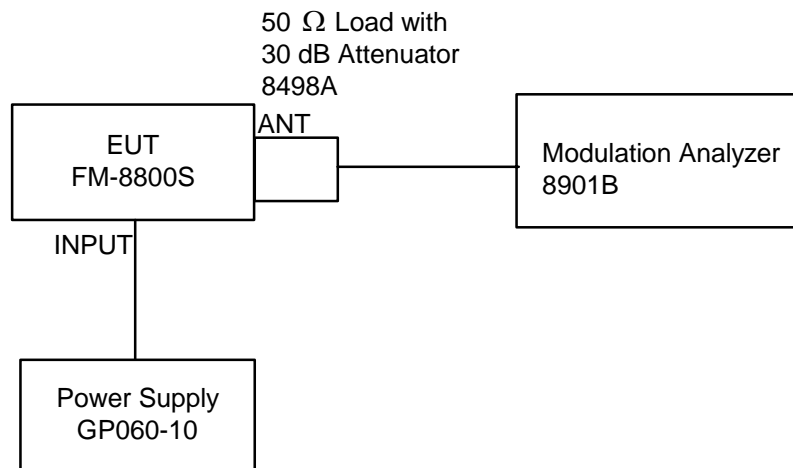

Fig. 3.1.1

3.1.1.2 List of Measuring/Test Equipment

See Clause 1.2 of this report.

3.1.1.3 Test Result

Results are shown below.

CH	Power Supply (VDC)	Output HI			Output LO		
		Carrier power (W)	Volt (VDC)	Current (A)	Carrier power (W)	Volt (VDC)	Current (A)
16 156.800 MHz	27.6	23.11	15.06	3.5	0.81	15.13	0.65
	24.0	23.11	15.07	3.5	0.81	15.13	0.65
	20.4	23.11	15.06	3.5	0.81	15.13	0.65
28 157.400 MHz	27.6	22.91	15.07	3.5	0.80	15.13	0.65
	24.0	22.90	15.07	3.5	0.80	15.13	0.65
	20.4	22.90	15.07	3.5	0.80	15.13	0.65
60 156.025 MHz	27.6	23.24	15.07	3.5	0.82	15.13	0.65
	24.0	23.24	15.07	3.5	0.82	15.13	0.65
	20.4	23.24	15.07	3.5	0.82	15.13	0.65

3.1.2 Output Power Variation

3.1.2.1 Setup for measurement

The EUT is placed in the temperature chamber and transmitter output (Carrier power) will be measured at ambient temperatures of -20, +25 and +55°C respectively on Channel 16 (156.800 MHz).

Test set-up is the same as those for Clause 3.1.1.1.

3.1.2.2 Measuring Equipment List:

See Clause 1.2 of this report.

3.1.2.3 Test Result

Table 3.1.2 Channel 16

Temp.	Power Supply (VDC)	Carrier power (W)	
		HI	LO
- 20°C	20.4	22.63	0.70
	24.0	22.63	0.70
	27.6	22.64	0.70
+ 25°C	20.4	23.11	0.81
	24.0	23.11	0.81
	27.6	23.11	0.81
+ 55°C	20.4	22.00	0.80
	24.0	22.00	0.80
	27.6	22.00	0.80

3.2 Modulation Characteristics (FCC Rule Part 2.1047)

3.2.1 Audio Frequency Response (FCC Rules Part 2.987 (a) (b) & 80.213)

3.2.1.1 Method of Measurement

- (1) The EUT will be connected with measuring equipment as shown in Fig. 3.2.1.1.
- (2) A modulation signal at a frequency of 1 kHz will be applied to the transmitter and the deviation will be measured at the output. The audio input level will be adjusted so that the frequency deviation is ± 1 kHz. This is the reference point in Fig. 3.2.1.2 (1 kHz corresponds to 0 dB).
The modulation frequency will then be varied between 100 Hz and 40 kHz, with the level of the audio frequency signal being kept constant and equal to the value specified above.

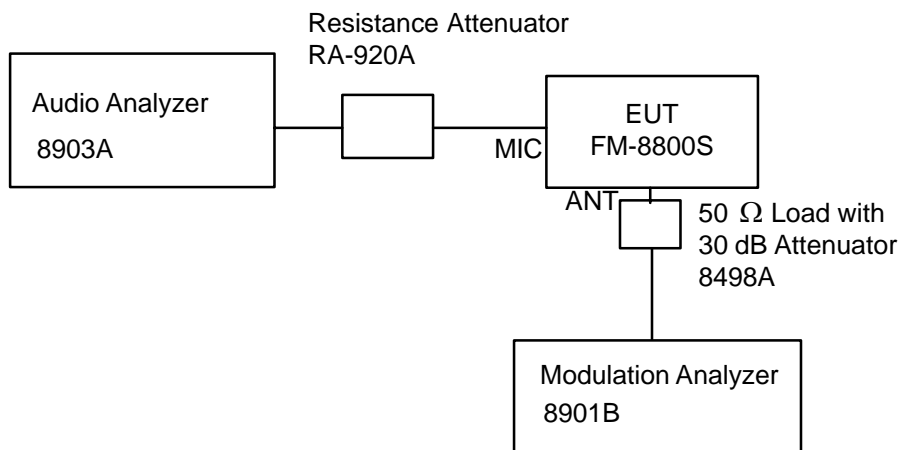

Fig. 3.2.1.1

3.2.1.2 List of Measuring/Test Equipment

See Clause 1.2 of this report.

3.2.1.3 Test Result

- (1) Overall modulation characteristics:
Results are shown in Fig.3.2.1.2.
- (2) Audio Low-Pass filter characteristics:
The characteristics of Audio Low-pass filter are generated by the software used for DSP (Digital Signal Processor).
See Fig. (2.1.1-7) described in Subclause 5.2 of this report for details.

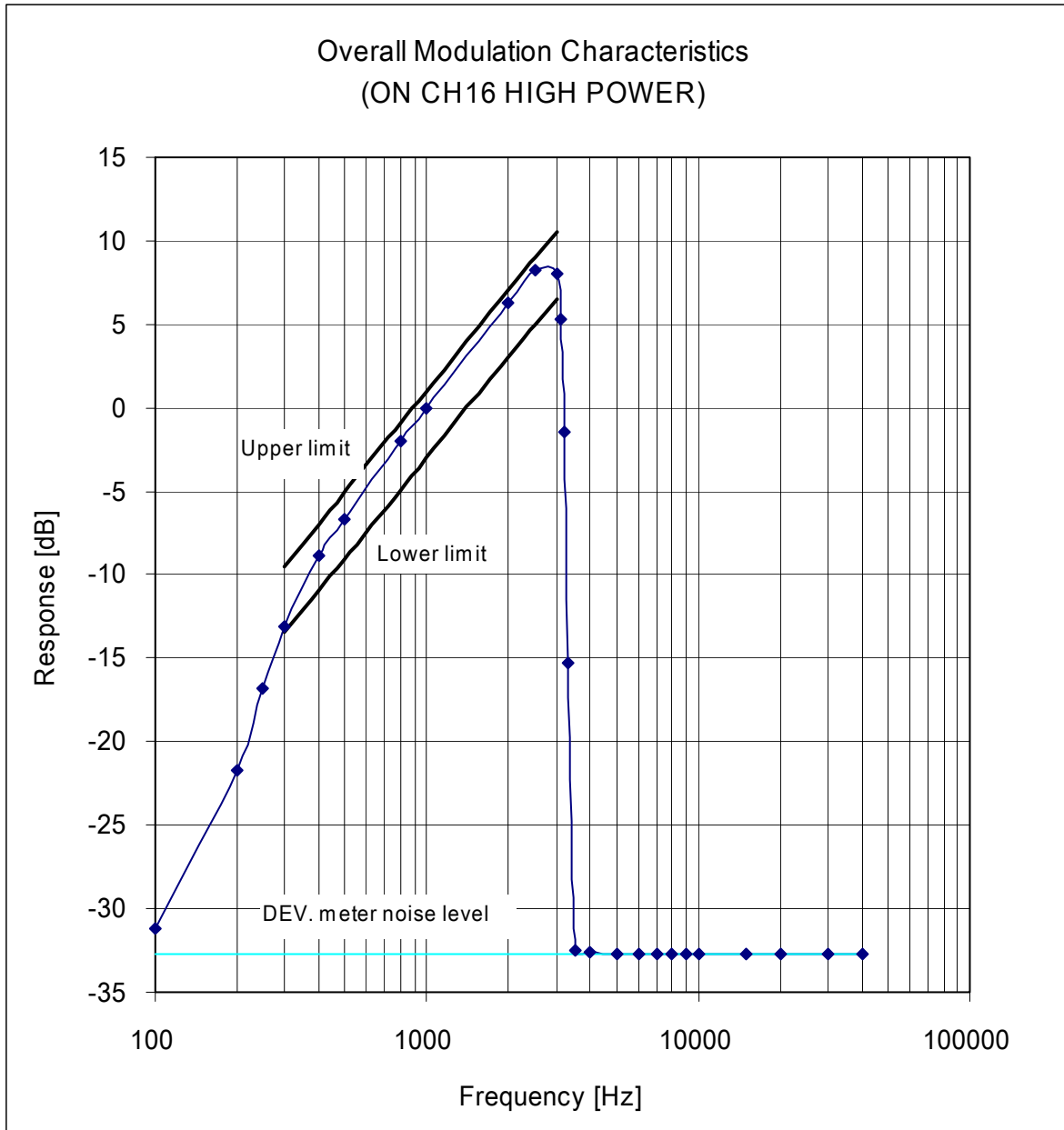

Fig. 3.2.1.2 Audio Frequency Response

3.2.2 Modulation Limiting (FCC Rule Part 2.1047)

3.2.2.1 Method of Measurement

A modulation signal at a frequency of 1 kHz will be applied to the transmitter, and its level adjusted so that the frequency deviation becomes to ± 1 kHz. The level of the modulation signal will then be increased by 20 dB and the deviation will again be measured.

The deviation will be also measured with the modulation signal at 300 Hz and 3 kHz respectively.

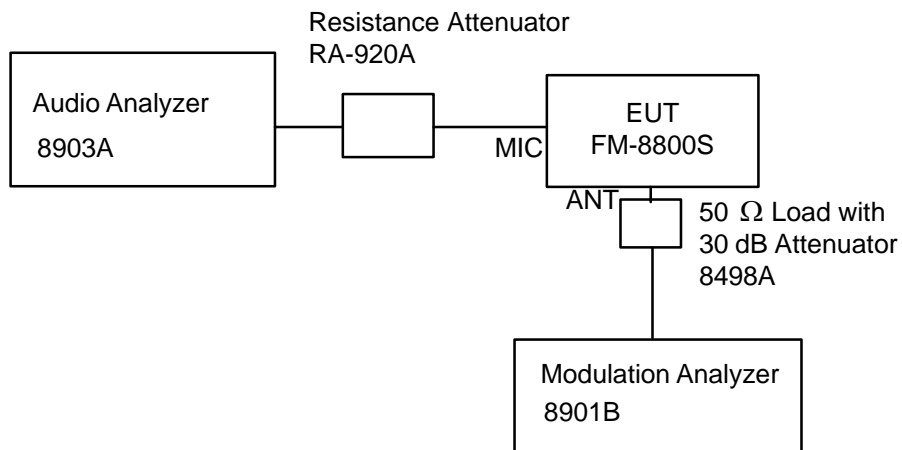

Fig. 3.2.2.1 Setup for measurement

3.2.2.2 List of Measuring/Test Equipment

See Clause 1.2 of this report.

3.2.2.3 Test Result

The results are shown in Fig. 3.2.2.3.

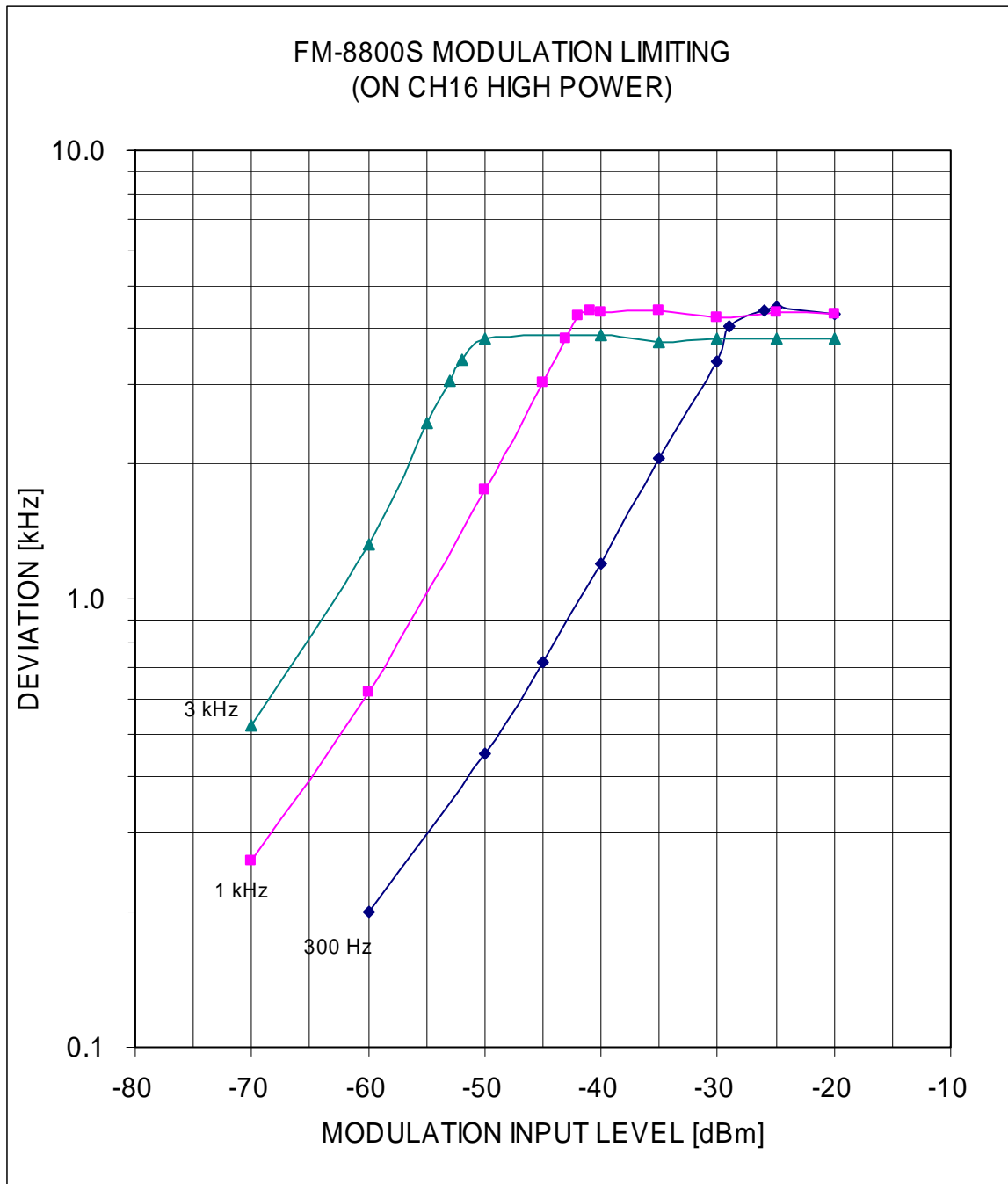

Fig. 3.2.2.3

3.3 Occupied Bandwidth (FCC Rule Part 2.1049 & 80.211)

3.3.1 Method of Measurement

- (1) The FM-8800S will be connected with measuring equipment as shown in Fig. 3.3.1.
- (2) Test Channel: CH60, CH16 and CH28.
Tests will be done with modulation by a 2500 Hz tone at an input level 16 dB greater than that necessary to produce 50% modulation.
- (3) CH70:
Tests will be done with modulation by a 1300 Hz and 2100 Hz tone.

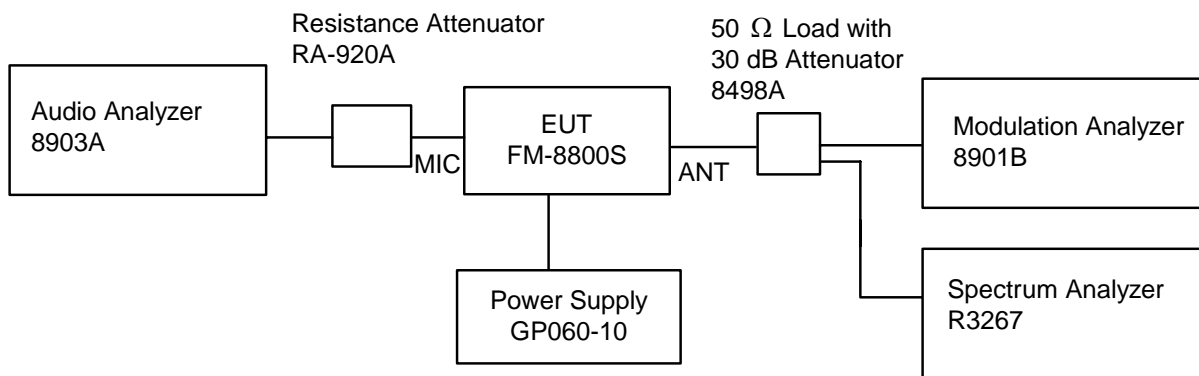

Fig. 3.3.1

3.3.2 List of Measuring/Test Equipment

See Clause 1.2 of this report.

3.3.3 Test Result

Results are shown in Fig. 3.3.2 to 3.3.11

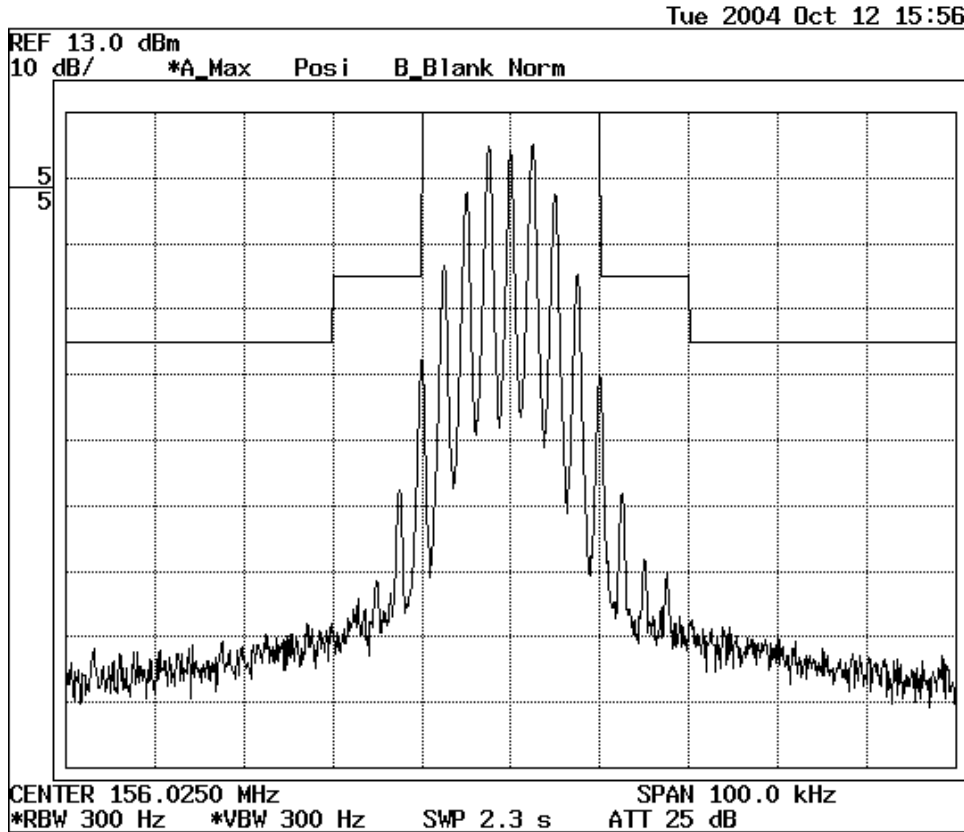

Fig. 3.3.2 - (CH60, High power)

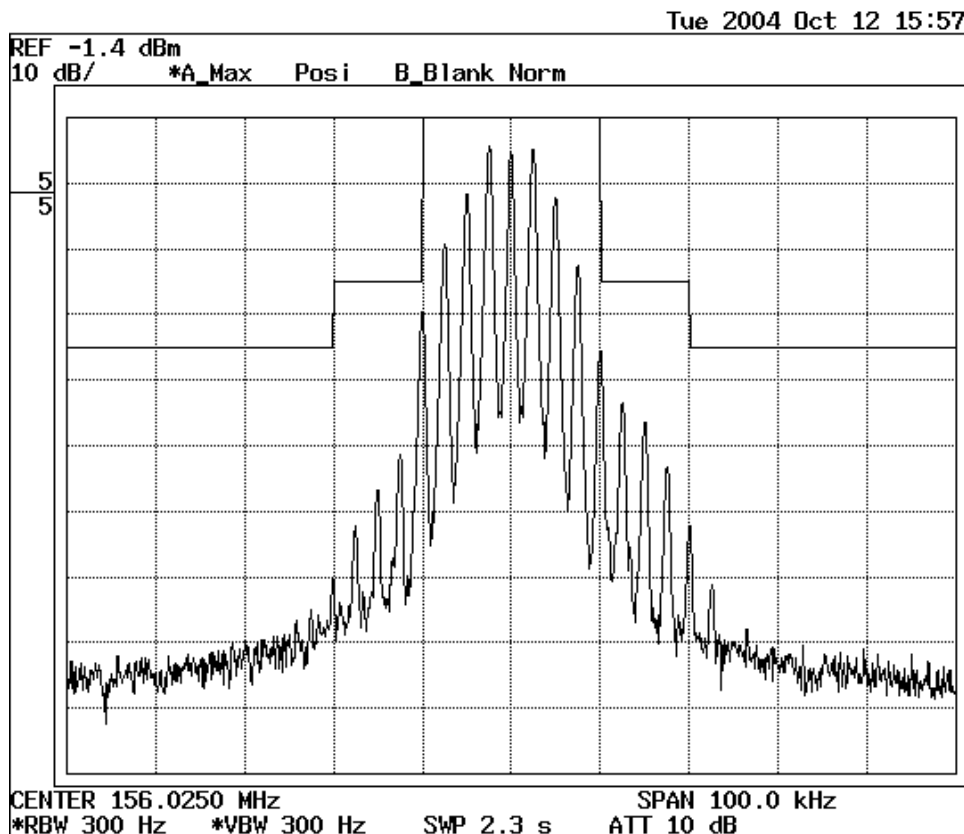

Fig. 3.3.3 - (CH60, Low power)

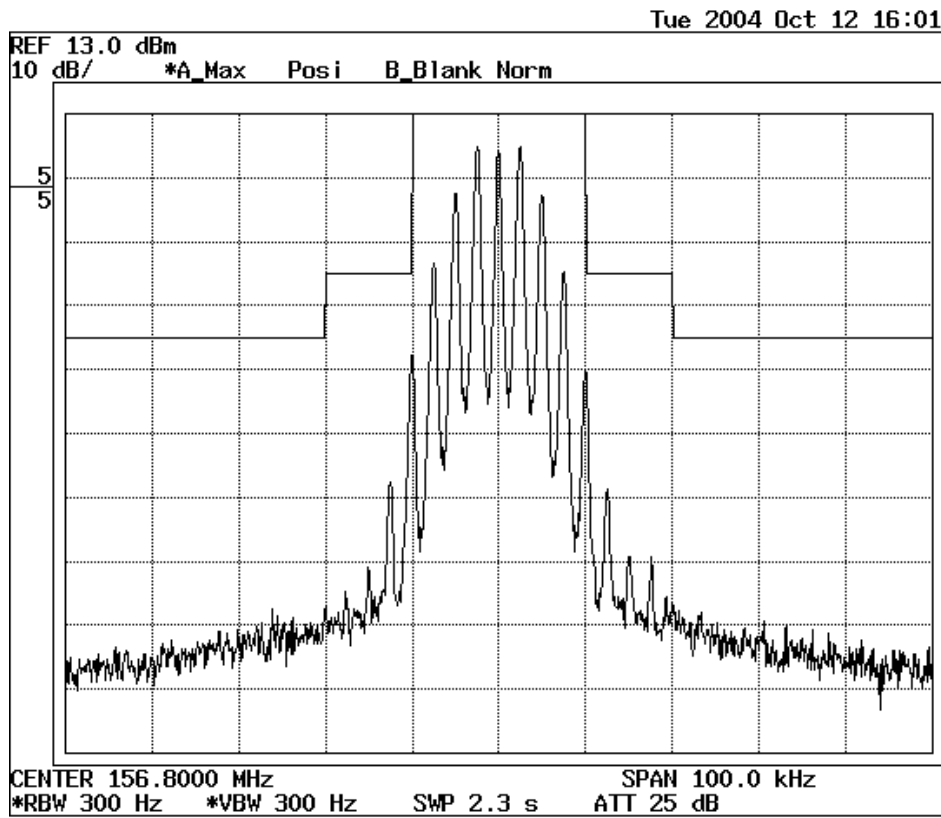

Fig. 3.3.4 - (CH16, High power)

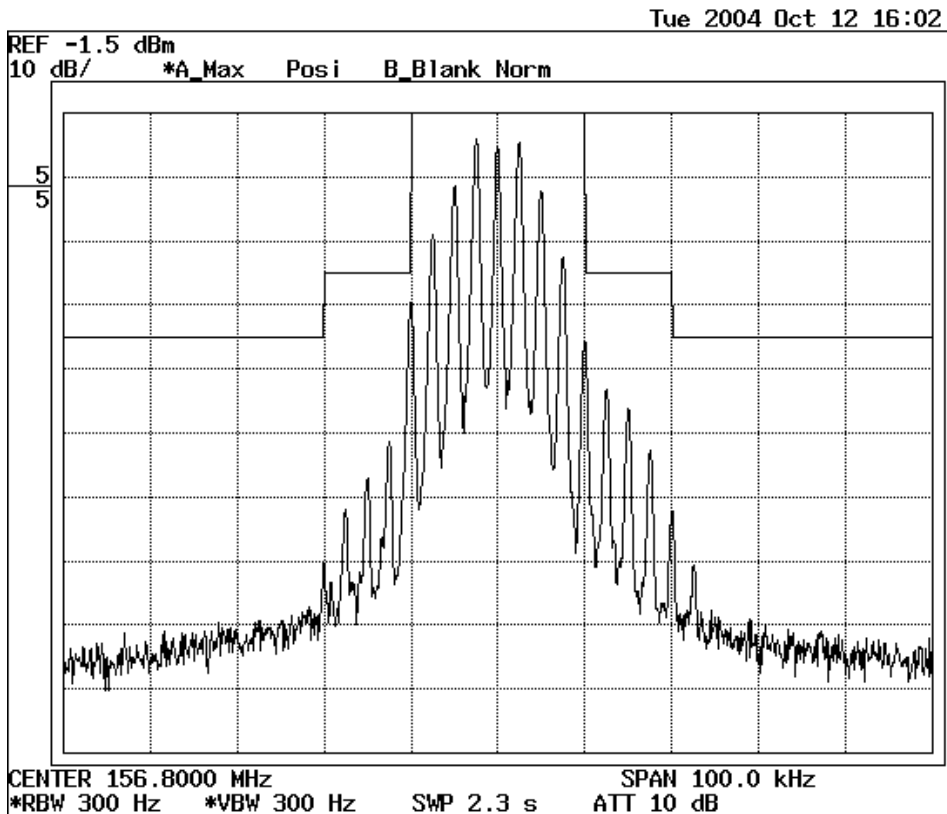

Fig. 3.3.5 - (CH16, Low power)

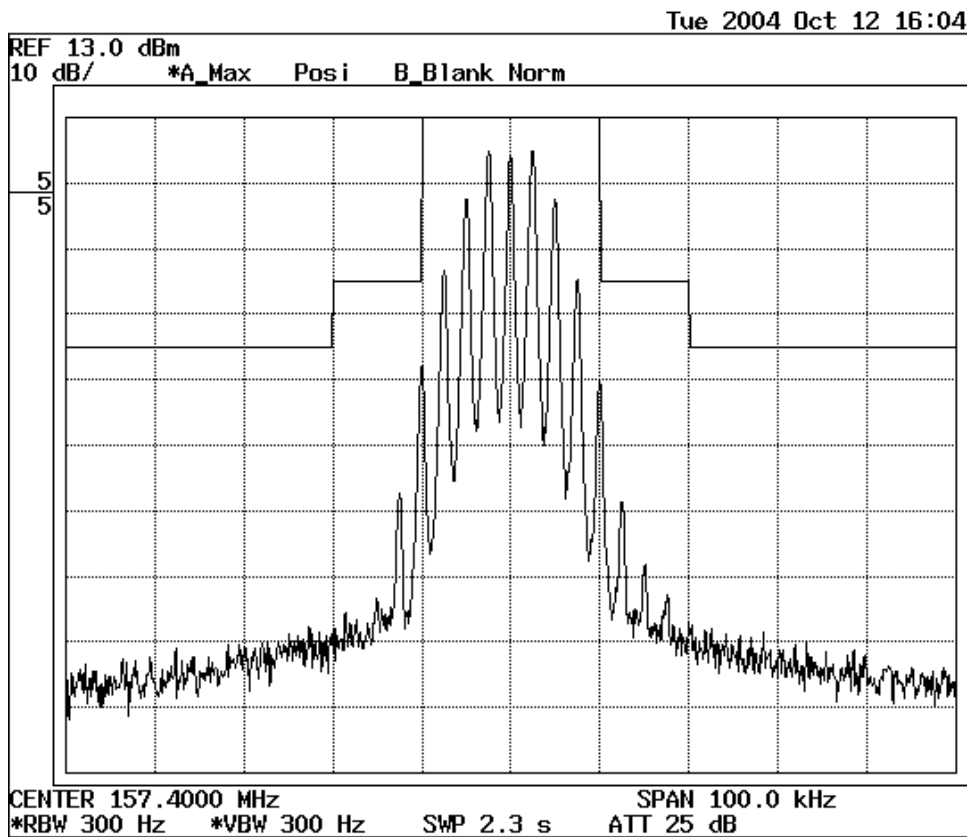

Fig. 3.3.6 - (CH28, High power)

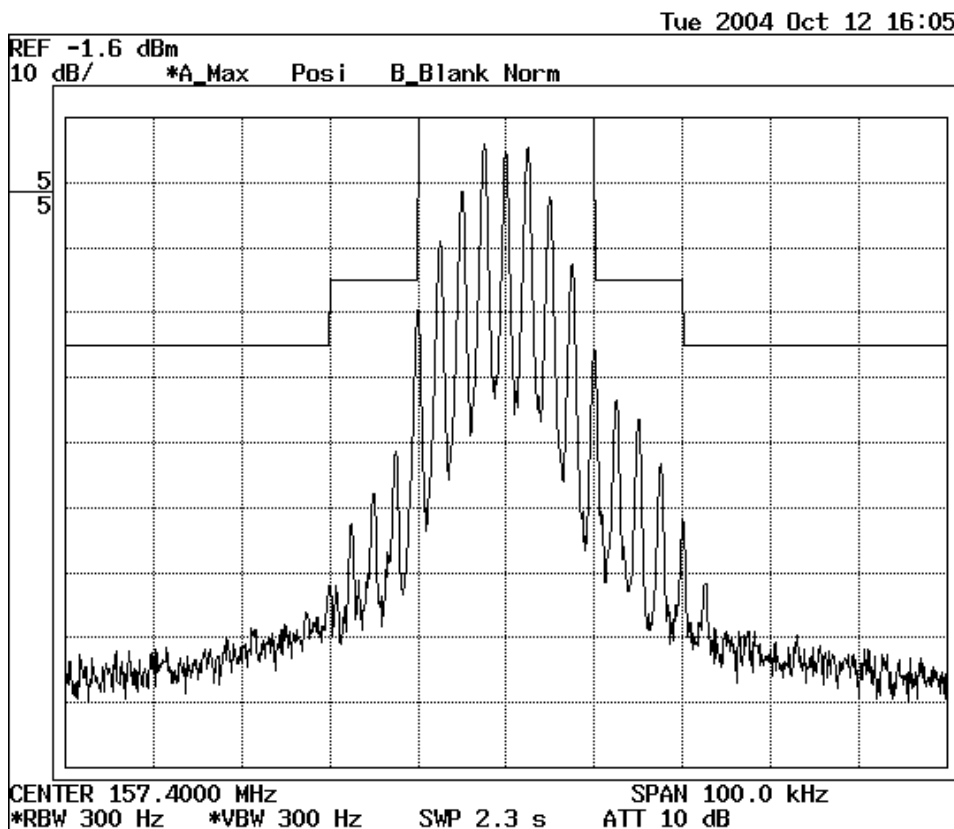

Fig. 3.3.7 - (CH28, Low power)

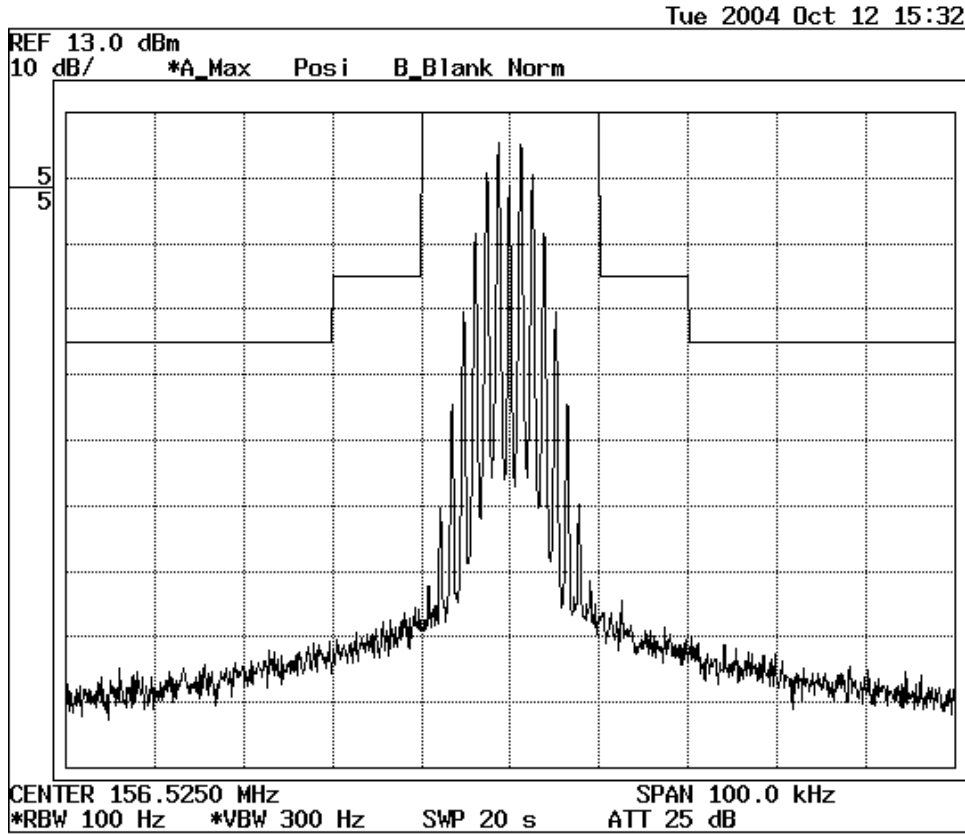

Fig. 3.3.8 - (CH70, High power, 1300 Hz)

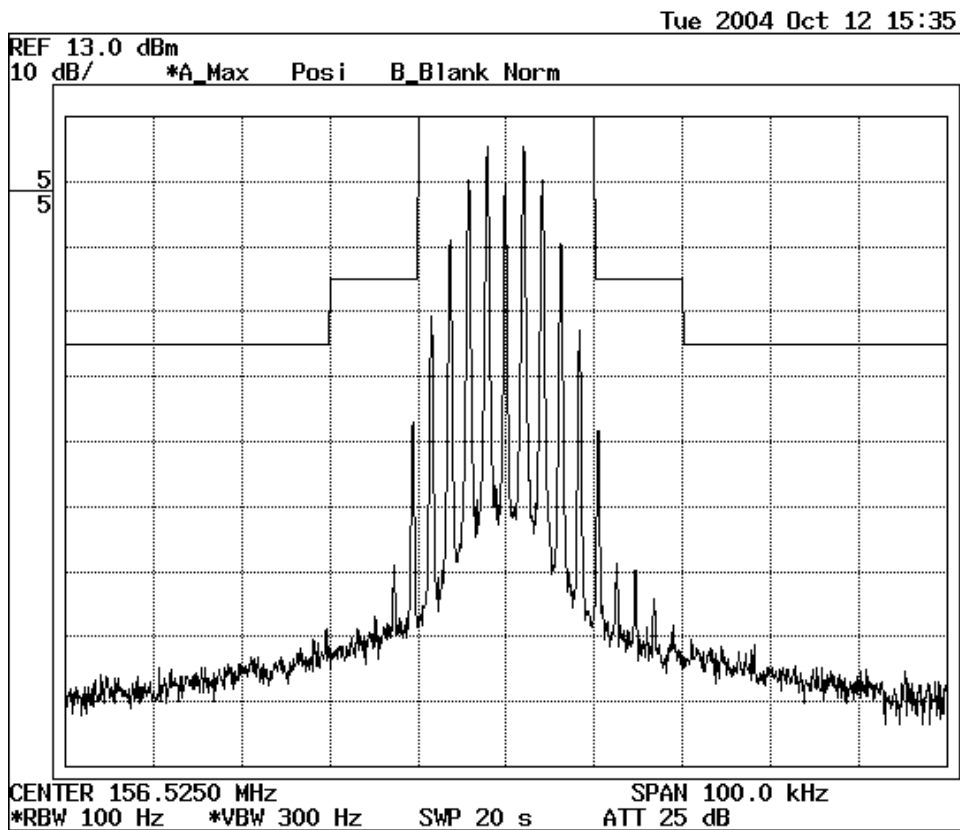

Fig. 3.3.9 - (CH70, High power, 2100 Hz)

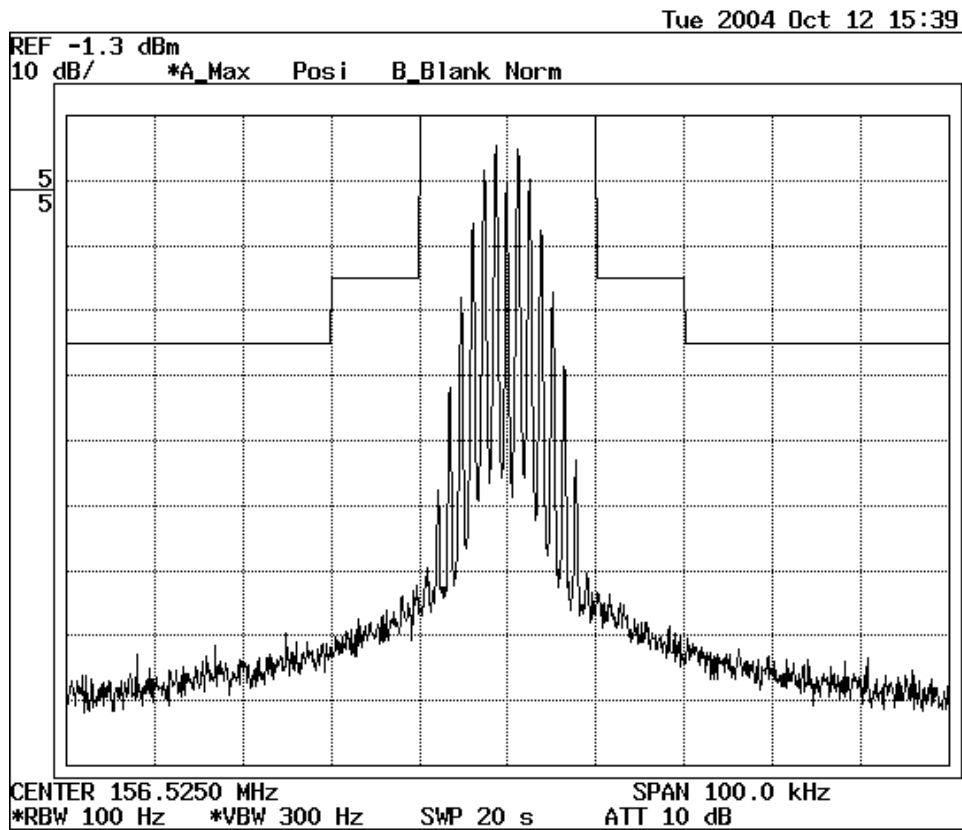

Fig. 3.3.10 - (CH70, Low power, 1300 Hz)

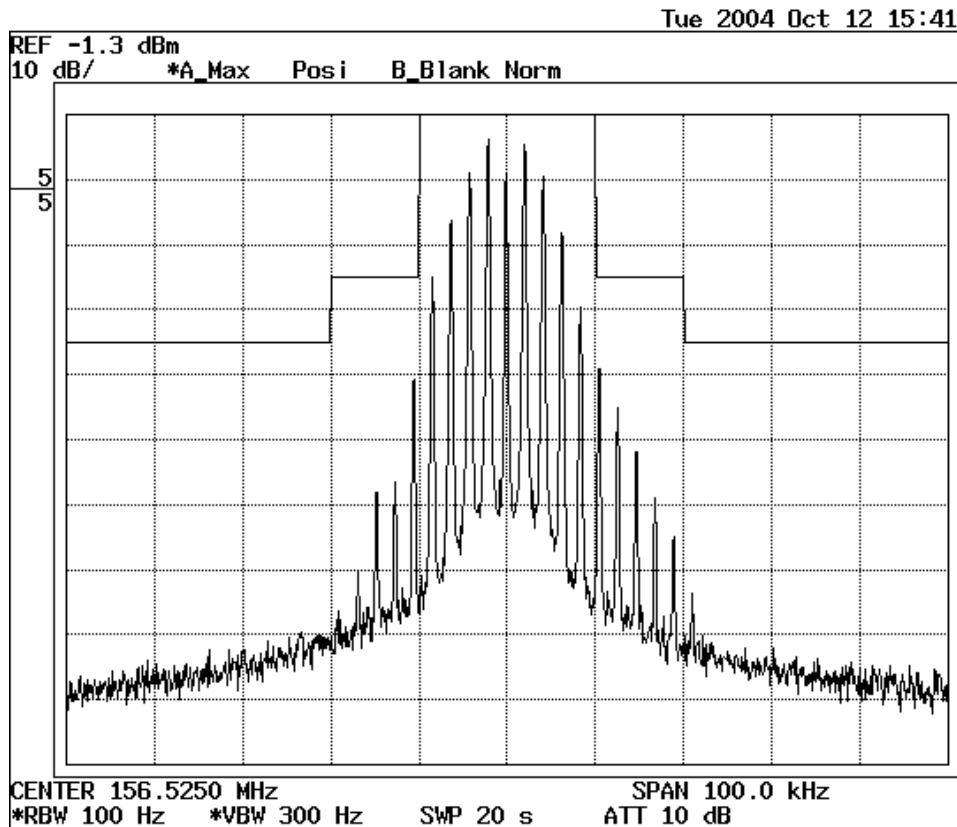

Fig. 3.3.11 - (CH70, Low power, 2100 Hz)

3.4 Spurious Emissions at Antenna Terminal (FCC Rule Part 2.1051 & 80.211)

3.4.1 Method of Measurement

- (1) The EUT will be connected with measuring equipment as shown in Fig.3.4.1.
- (2) Radio frequency voltage generated within the EUT and appearing on a spurious frequency was measured at the output terminal when loaded with 50-ohm artificial antenna.
- (3) Modulation input level:
16 dB greater than that necessary to produce 50% modulation when modulated by a 2500 Hz tone.

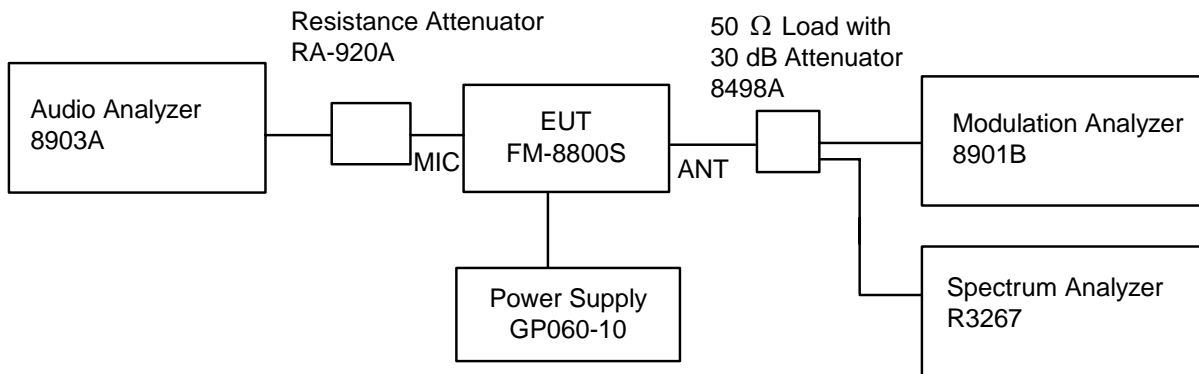

Fig. 3.4.1

3.4.2 List of Measuring/Test Equipment

See Clause 1.2 of this report.

3.4.3 Emission limits

- < -57 dB below carrier at High power,
- < -43 dB below carrier at Low power

3.4.5 Test results:

The spurious emissions at antenna terminal of EUT were found lower than the specified limits.

(Note: Spurious emissions at the frequencies for more than 1 GHz were not found.)

f	CH60(156.026 MHz)		CH16 (156.800 MHz)		CH28 (157.400 MHz)	
	High power	Low power	High power	Low power	High power	Low power
44.5 MHz	Not found	-75.3	Not found	-74.9	Not found	-75.7
2f	-69.9	-73.1	-69.8	-73.7	-72.4	-73.4
3f	-75.0	-77.2	-75.6	-78.4	-76.4	-78.5
4f	Not found	Not found	Not found	Not found	Not found	Not found
5f	Not found	Not found	Not found	Not found	Not found	Not found

(dB)

Results are shown in Fig.3.4.5.1 to Fig.3.4.5.12.

Fig.No.	Test Channel	Frequency range	Output Power
3.4.5.1	60	10 kHz to 500 MHz	High
3.4.5.2		500 MHz to 2 GHz	
3.4.5.3		10 kHz to 500 MHz	Low
3.4.5.4		500 MHz to 2 GHz	
3.4.5.5	16	10 kHz to 500 MHz	High
3.4.5.6		500 MHz to 2 GHz	
3.4.5.7		10 kHz to 500 MHz	Low
3.4.5.8		500 MHz to 2 GHz	
3.4.5.9	28	10 kHz to 500 MHz	High
3.4.5.10		500 MHz to 2 GHz	
3.4.5.11		10 kHz to 500 MHz	Low
3.4.5.12		500 MHz to 2 GHz	

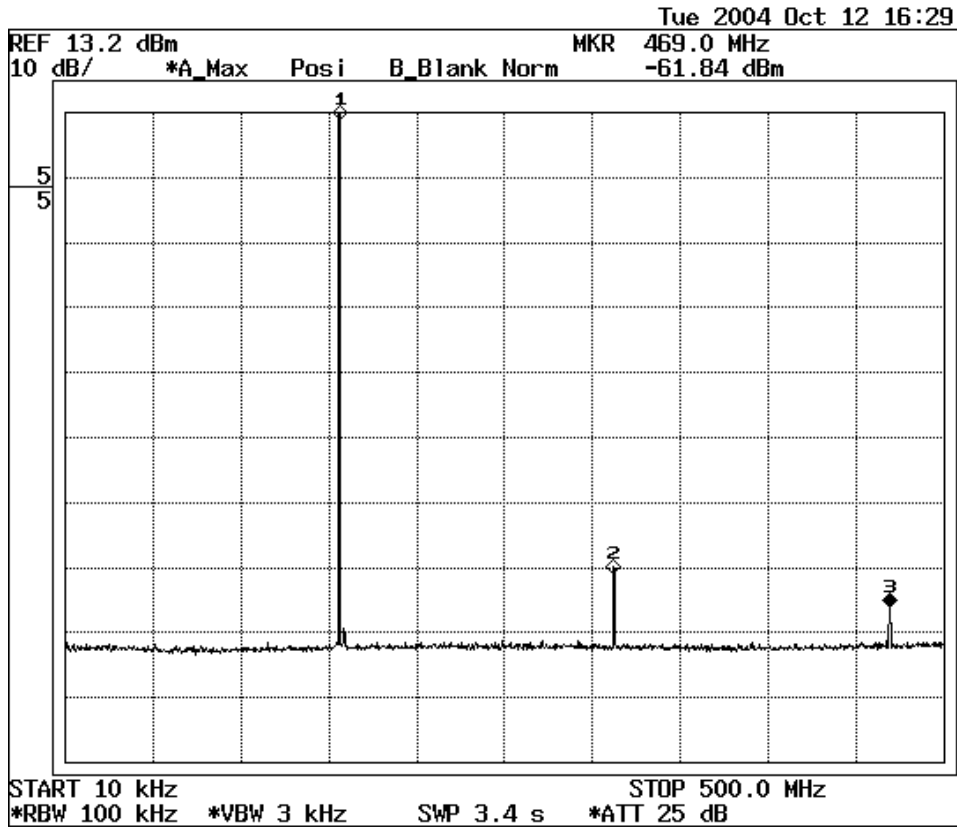

Fig. 3.4.5.1 - (CH60, High power)



Fig. 3.4.5.2 - (CH60, High power)

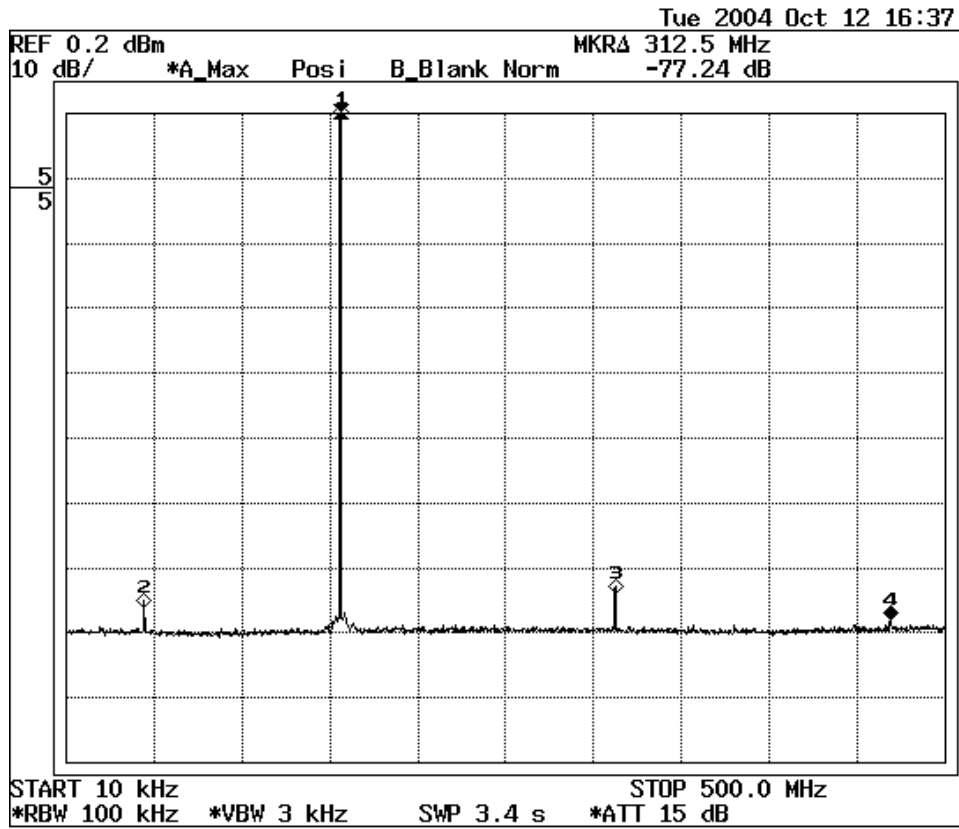

Fig. 3.4.5.3 - (CH60, Low power)



Fig. 3.4.5.4 - (CH60, Low power)

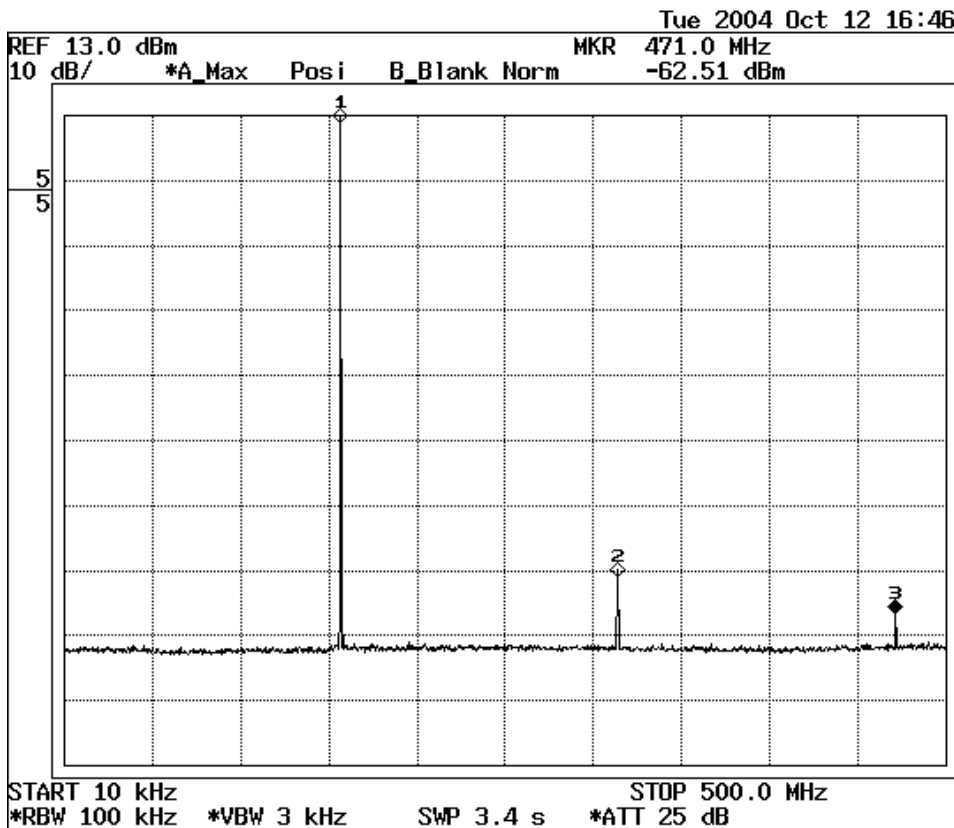

Fig. 3.4.5.5 - (CH16, High power)

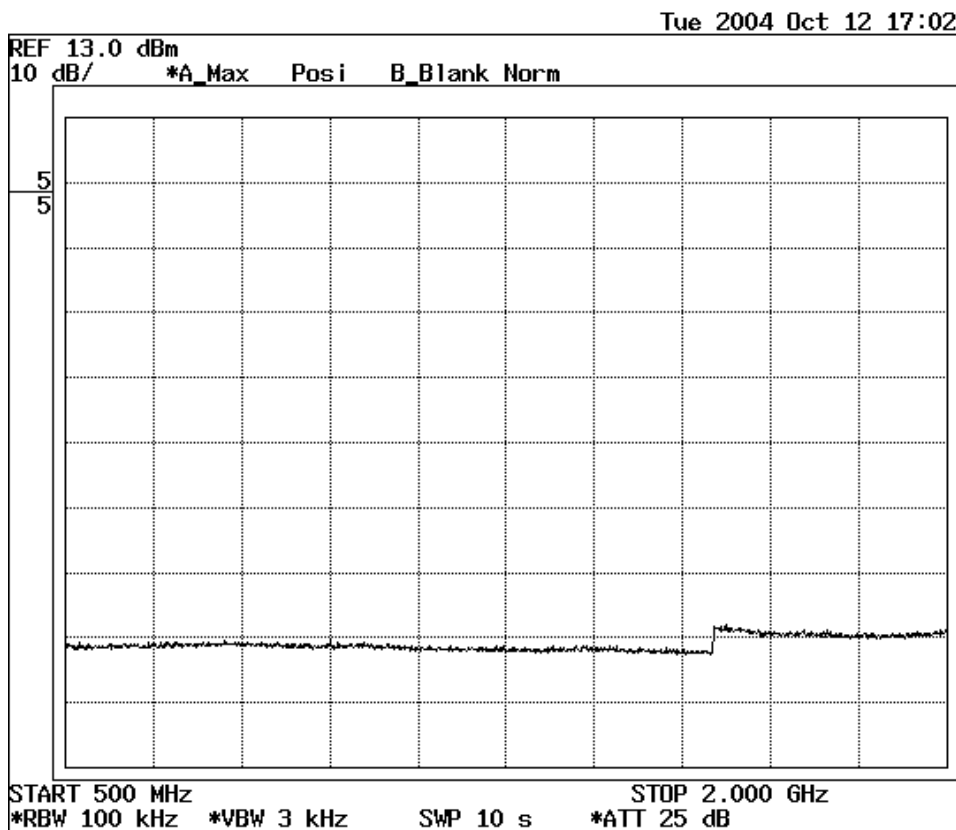

Fig. 3.4.5.6 - (CH16, High power)

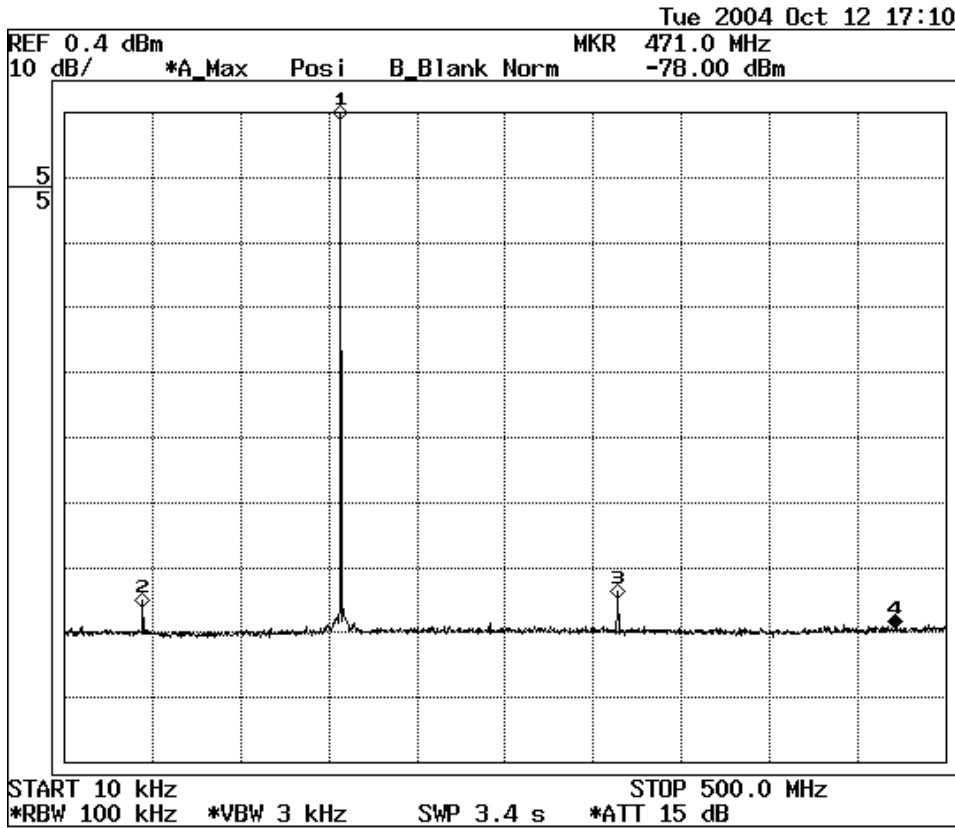

Fig. 3.4.5.7 - (CH16, Low power)

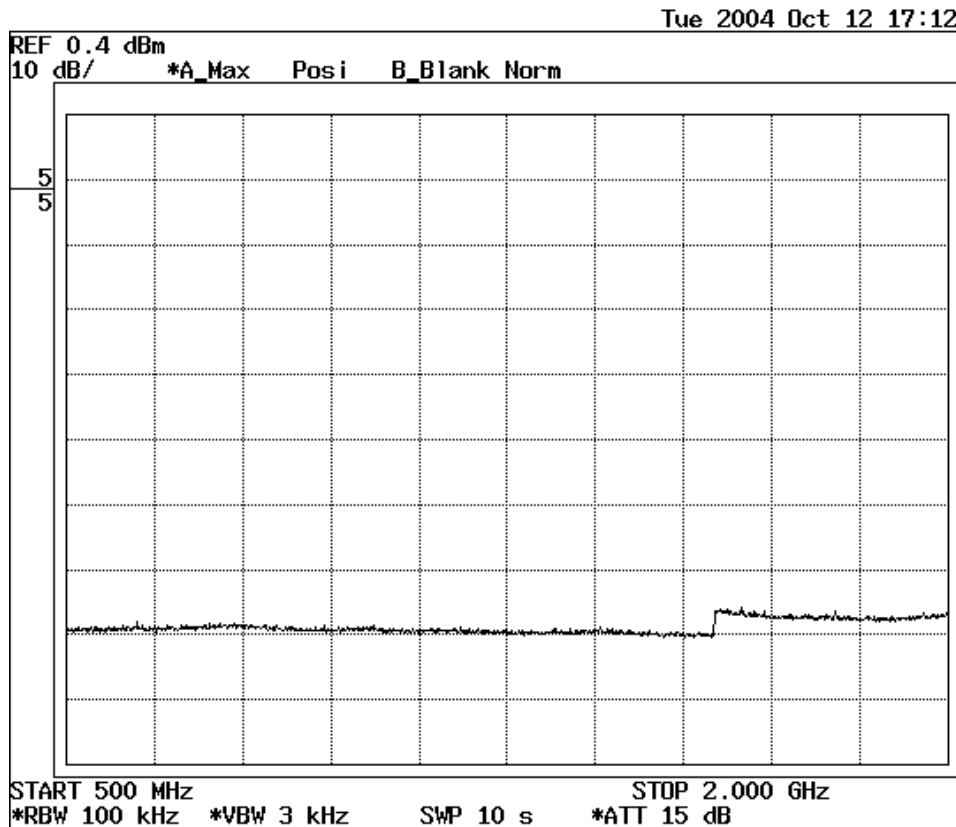

Fig. 3.4.5.8 - (CH16, Low power)

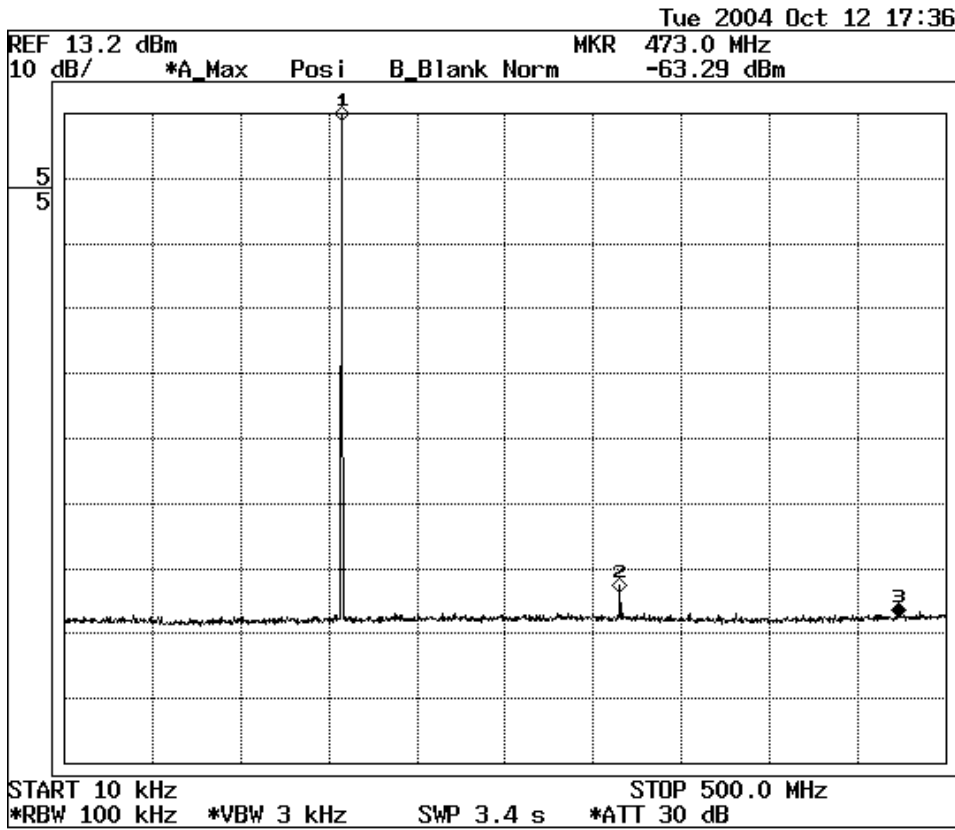

Fig. 3.4.5.9 - (CH28, High power)

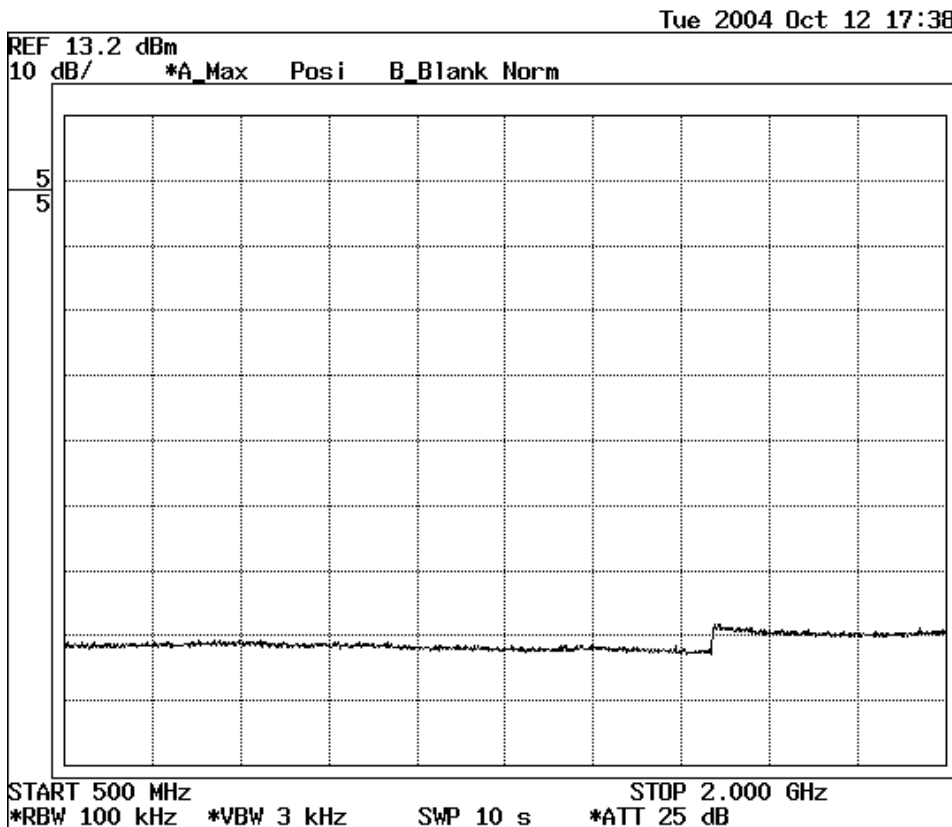

Fig. 3.4.5.10 - (CH28, High power)

3.5 Field Strength of Spurious Radiation (FCC Rule Part 2.1053)

3.5.1 Method of Measurement

3.5.1.1 Test sight Nishinomiya-Hama site Anechoic chamber
FCC Registration Number: 90607
FURUNO LABOTECH INTERNATIONAL CO., LTD.
Nishinomiya-hama 2-20, Nishinomiya-city, 662-0934 Japan

3.5.1.2 Distance between the EUT and measuring antenna: 3 m

3.5.1.3 List of Measuring/Test Equipment

See Clause 1.2 of this report.

3.5.1.4 Test set-up

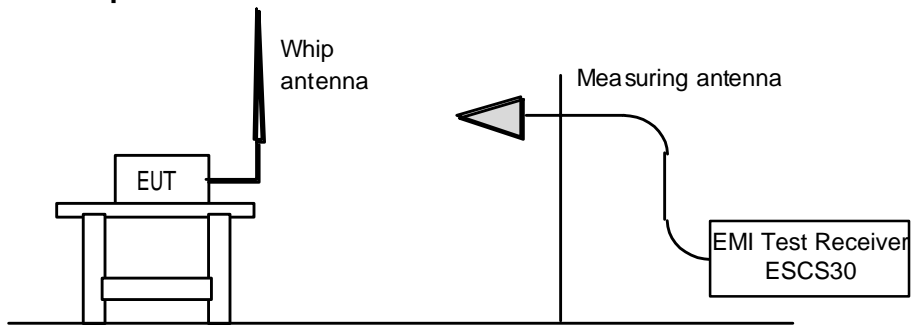

Fig 3.5.1.4A Setup for measurement of fundamental component

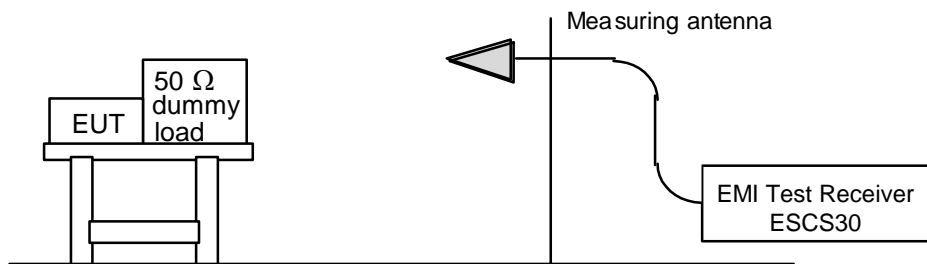

Fig 3.5.1.4B Setup for measurement of any spurious components other than fundamental component

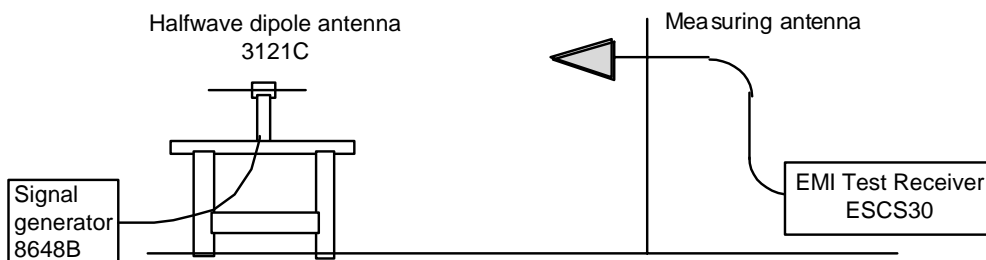

Fig 3.5.1.4C Setup for measurement of field strength by using substitution antenna

3.5.1.5 Method of measurement

- (1) With the test setup described in Fig. 3.5.1.4A, Field strength of TX fundamental component will be measured.
- (2) With the test setup described in Fig. 3.5.1.4B, Field strength of each spurious component other than TX fundamental component will be measured.
- (3) With the test setup described in Fig. 3.5C, Field strength generated by the Signal Generator with the substitution antenna for the fundamental and spurious frequencies will be measured. (Substitution method for calculation of the radiated power)

3.5.1.6 Field Strength Limits

- <-57 dB below carrier at High power,
- <-43 dB below carrier at Low power

3.5.1.7 Measurement Results

- 1) Field strength of fundamental component (Refer to Fig 3.5.1.4A)

Test channel	High power (25 W)		Low power (1 W)	
	Horizontal plane (dB μ V/m)	Vertical plane (dB μ V/m)	Horizontal plane (dB μ V/m)	Vertical plane (dB μ V/m)
60 (156.025 MHz)	118.5	138.6	104.5	124.3
16 (156.800 MHz)	118.8	138.3	104.7	124.7
28 (157.400 MHz)	118.1	138.9	105.2	124.4

- 2) Field strength of each spurious components (Refer to Fig 3.5.1.4B)

Test channel	High power (25 W)		Low power (1 W)	
	Horizontal plane (dB μ V/m)	Vertical plane (dB μ V/m)	Horizontal plane (dB μ V/m)	Vertical plane (dB μ V/m)
60 (156.025 MHz)				
2f (312.050 MHz)	Not found	Not found	Not found	Not found
3f (468.075 MHz)	27.3	28.6	24.1	22.9
4f (624.100 MHz)	36.2	35.7	22.5	24.5
5f (780.125 MHz)	39.1	34.5	26.4	Not found
6f (936.150 MHz)	Not found	Not found	Not found	Not found
7f (1092.175 MHz)	Not found	Not found	Not found	Not found
8f (1248.200 MHz)	32.1	34.4	Not found	Not found
9f (1404.225 MHz)	37.5	37.4	35.1	35.8
10f (1560.250 MHz)	Not found	Not found	Not found	Not found

Test channel	High power (25 W)		Low power (1 W)	
	Horizontal plane (dB μ V/m)	Vertical plane (dB μ V/m)	Horizontal plane (dB μ V/m)	Vertical plane (dB μ V/m)
16 (156.800 MHz)				
2f (313.600 MHz)	18.4	Not found	Not found	Not found
3f (470.400 MHz)	31.7	28.3	26.5	24.7
4f (627.200 MHz)	36.1	36.5	23.0	23.6
5f (784.000 MHz)	37.4	36.0	27.8	Not found
6f (940.800 MHz)	Not found	Not found	Not found	Not found
7f (1097.600 MHz)	Not found	Not found	Not found	Not found
8f (1254.400 MHz)	32.2	34.9	Not found	Not found
9f (1411.200 MHz)	35.5	35.4	35.4	34.6
10f (1568.000 MHz)	Not found	Not found	Not found	Not found

Test channel	High power (25 W)		Low power (1 W)	
	Horizontal plane (dB μ V/m)	Vertical plane (dB μ V/m)	Horizontal plane (dB μ V/m)	Vertical plane (dB μ V/m)
28 (157.400 MHz)				
2f (314.800 MHz)	Not found	Not found	Not found	Not found
3f (472.200 MHz)	33.6	28.8	23.6	22.3
4f (629.600 MHz)	39.1	39.3	Not found	23.8
5f (787.000 MHz)	38.7	37.7	27.7	Not found
6f (944.400 MHz)	Not found	Not found	Not found	Not found
7f (1101.800 MHz)	Not found	Not found	Not found	Not found
8f (1259.200 MHz)	31.8	Not found	Not found	Not found
9f (1416.600 MHz)	Not found	34.4	36.2	34.6
10f (1574.000 MHz)	Not found	Not found	Not found	Not found

3) Field strength with substitution antenna (Refer to Fig 3.5.1.4C)

Signal generator		Radiated power with substitution antenna (dBm)	Field strength (dB μ V/m)	
Frequency (MHz)	Output level (dBm)		Horizontal plane	Vertical plane
156.025	-30	-29.57	69.7	66.0
156.800	-30	-29.56	69.4	65.8
157.400	-30	-29.59	69.4	65.8
312.050	-40	-39.78	59.1	56.8
313.600	-40	-39.79	59.0	55.7
314.800	-40	-39.80	59.1	55.7
468.075	-40	-40.36	57.1	57.0
470.400	-40	-40.39	57.2	56.3
472.200	-40	-40.40	57.4	55.9
624.100	-40	-40.81	55.2	52.4
627.200	-40	-40.83	55.6	52.7
629.600	-40	-40.86	55.8	52.8
780.125	-40	-41.05	57.3	55.1
784.000	-40	-41.07	58.2	54.8
787.000	-40	-41.09	58.5	54.8
936.150	-40	-41.18	59.7	56.8
940.800	-40	-41.21	59.3	56.6
944.400	-40	-41.24	59.7	57.1
1000 - 1800	-63.2	-56.98	42.9	43.5

3.5.1.8 Test Results

Calculation of Spurious Attenuation by using Substitution Method:

(1) Calculation of Radiated Power (X1) of the TX fundamental component:

$$X1 = ((\text{Field Strength of Fundamental Component}) - (\text{Field Strength measured with Substitution Ant.})) + (\text{Radiated Power with Substitution Ant.})$$

(2) Calculation of Radiated Power (X2) of each spurious component:

$$X2 = ((\text{Field Strength of Spurious Component}) - (\text{Field Strength measured with Substitution Ant.})) + (\text{Radiated Power with Substitution Ant.})$$

(3) Calculation of Spurious Attenuation:

$$\text{Spurious Attenuation (dB)} = (X1) - (X2)$$

(4) Results of Spurious Attenuation:

Test channel: CH60 (156.025 MHz) on High power

	Frequency (MHz)	X1 (dBm)		X2 (dBm)		Attenuation (dB)	
		Horizontal	Vertical	Horizontal	Vertical	Horizontal	Vertical
Fundamental	156.025	19.2	43.0			0	0
Spurious	312.050			Not found	Not found	Not found	Not found
	468.075			-70.2	-68.8	89.4	111.8
	624.100			-59.8	-57.5	79.0	100.5
	780.125			-59.3	-61.7	78.5	104.7
	936.150			Not found	Not found	Not found	Not found
	1092.175			Not found	Not found	Not found	Not found
	1248.200			-67.8	-66.1	87.0	109.1
	1404.225			-62.4	-63.1	81.6	106.1
	1560.250			Not found	Not found	Not found	Not found

Test channel: CH60 (156.025 MHz) on Low power

	Frequency (MHz)	X1 (dBm)		X2 (dBm)		Attenuation (dB)	
		Horizontal	Vertical	Horizontal	Vertical	Horizontal	Vertical
Fundamental	156.025	5.2	28.7	/	/	0	0
Spurious	312.050	/	/	Not found	Not found	Not found	Not found
	468.075	/	/	-73.4	-74.5	78.6	103.2
	624.100	/	/	-73.5	-68.7	78.7	97.4
	780.125	/	/	-72.0	Not found	77.2	Not found
	936.150	/	/	Not found	Not found	Not found	Not found
	1092.175	/	/	Not found	Not found	Not found	Not found
	1248.200	/	/	Not found	Not found	Not found	Not found
	1404.225	/	/	-64.8	-64.7	70.0	93.4
	1560.250	/	/	Not found	Not found	Not found	Not found

Test channel: CH16 (156.800 MHz) on High power

	Frequency (MHz)	X1 (dBm)		X2 (dBm)		Attenuation (dB)	
		Horizontal	Vertical	Horizontal	Vertical	Horizontal	Vertical
Fundamental	156.800	19.8	42.9	/	/	0	0
Spurious	313.600	/	/	-80.4	Not found	100.2	Not found
	470.400	/	/	-65.9	-68.4	85.7	111.3
	627.200	/	/	-60.3	-57.0	80.1	99.9
	784.000	/	/	-61.9	-59.9	81.7	102.8
	940.800	/	/	Not found	Not found	Not found	Not found
	1097.600	/	/	Not found	Not found	Not found	Not found
	1254.400	/	/	-67.7	-65.6	87.5	108.5
	1411.200	/	/	-64.4	-65.1	84.2	108.0
		1568.000	/	/	Not found	Not found	Not found

Test channel: CH16 (156.800 MHz) on Low power

	Frequency (MHz)	X1 (dBm)		X2 (dBm)		Attenuation (dB)	
		Horizontal	Vertical	Horizontal	Vertical	Horizontal	Vertical
Fundamental	156.800	5.5	29.0	/	/	0	0
Spurious	313.600	/	/	Not found	Not found	Not found	Not found
	470.400	/	/	Not found	Not found	Not found	Not found
	627.200	/	/	-71.6	-69.7	77.1	98.7
	784.000	/	/	-62.3	-57.5	67.8	86.5
	940.800	/	/	Not found	-68.4	Not found	97.4
	1097.600	/	/	Not found	Not found	Not found	Not found
	1254.400	/	/	Not found	Not found	Not found	Not found
	1411.200	/	/	Not found	-65.9	Not found	94.9
		1568.000	/	/	-63.1	Not found	68.6

Test channel: CH28 (157.400 MHz) on High power

	Frequency (MHz)	X1 (dBm)		X2 (dBm)		Attenuation (dB)	
		Horizontal	Vertical	Horizontal	Vertical	Horizontal	Vertical
Fundamental	157.400	19.1	43.5	/	/	0	0
Spurious	314.800	/	/	Not found	Not found	Not found	Not found
	472.200	/	/	-64.2	-67.5	83.3	111.0
	629.600	/	/	-57.6	-54.4	76.7	97.9
	787.000	/	/	-60.9	-58.2	80.0	101.7
	944.400	/	/	Not found	Not found	Not found	Not found
	1101.800	/	/	Not found	Not found	Not found	Not found
	1259.200	/	/	-68.1	Not found	87.2	Not found
	1416.600	/	/	Not found	-66.1	Not found	109.6
	1574.000	/	/	Not found	Not found	Not found	Not found

Test channel: CH28 (157.400 MHz) on Low power

	Frequency (MHz)	X1 (dBm)		X2 (dBm)		Attenuation (dB)	
		Horizontal	Vertical	Horizontal	Vertical	Horizontal	Vertical
Fundamental	157.400	6.2	29.0	/	/	0	0
Spurious	314.800	/	/	Not found	Not found	Not found	Not found
	472.200	/	/	-74.2	-74.0	80.4	103.0
	629.600	/	/	Not found	-69.9	Not found	98.9
	787.000	/	/	-71.9	Not found	78.1	Not found
	944.400	/	/	Not found	Not found	Not found	Not found
	1101.800	/	/	Not found	Not found	Not found	Not found
	1259.200	/	/	Not found	Not found	Not found	Not found
	1416.600	/	/	-63.7	-65.9	69.9	94.9
	1574.000	/	/	Not found	Not found	Not found	Not found

Results of Spurious Attenuation are found lower than the specified limits.

3.6 Frequency Stability (FCC Rule Part 2.1055)

3.6.1 Method of Measurement

The EUT will be connected with the measuring equipment as shown in Fig.3.6.1
Frequency variation was measured on CH16 (156.800 MHz).

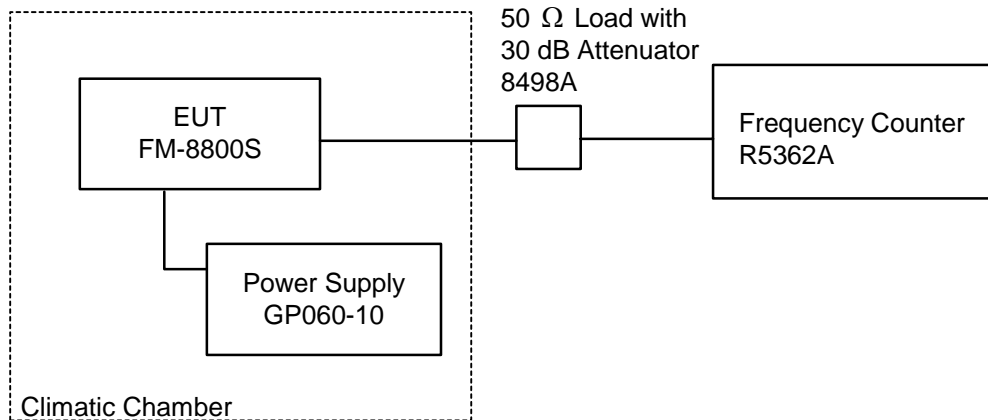

Fig.3.6.1 Setup for Measurement

3.6.2 List of Measuring/Test Equipment

See Clause 1.2 of this report.

3.6.3 Frequency Tolerance Limits

10 ppm (±1568.0 Hz for CH16 (156.800 MHz))

3.6.4 Test results:

Test results are shown in Fig. 3.6.4

Variation of power supply voltages (20.4 VDC to 24.7 VDC) did not affect the test results with the use of due to the built-in voltage regulator.

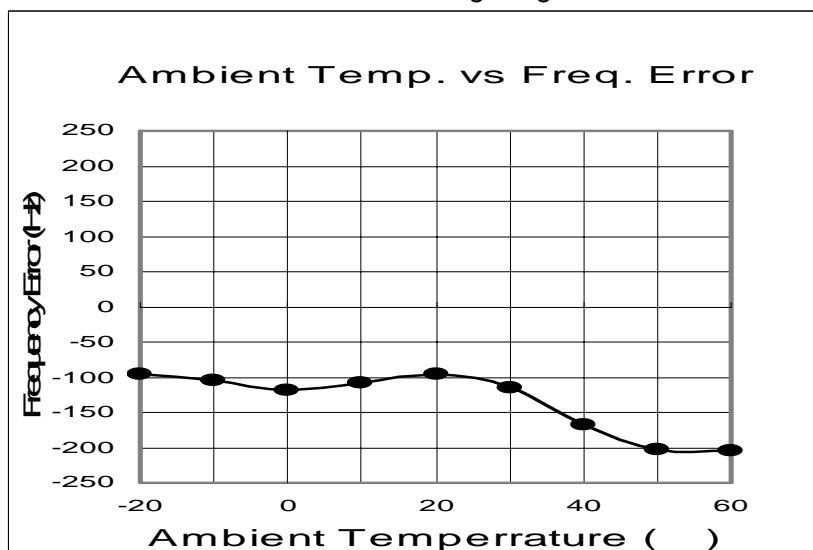

Fig. 3.6.4: Frequency stability

3.7 Maximum Usable Sensitivity for the Receiver (FCC Rule Part 80.874)

3.7.1 Method of Measurement

- (1) The EUT will be connected with measuring equipment as shown in Fig. 3.7.1.
- (2) A Input test signal at a Carrier frequency equal to the nominal frequency of the receiver, will be modulated by the normal test modulation.
- (3) Normal test modulation:
 Modulation frequency: 1 kHz
 Frequency deviation: ±3.5 kHz.
- (4) The level of the Input test signal will be adjusted so that a SINAD ratio of 12 dB is obtained.

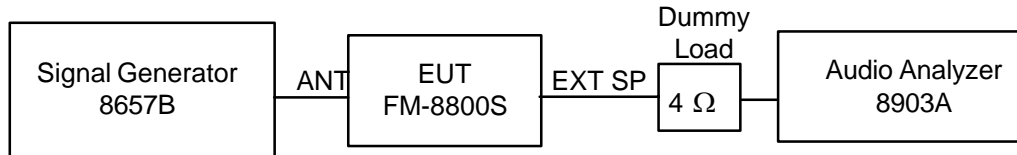

Fig. 3.9.1

3.7.2 List of Measuring/Test Equipment

See Clause 1.2 of this report.

3.7.3 Limits

Less than 0.5 μV.

3.7.4 Test results

Test channel	Power Supply		
	21.6 VDC	24.0 VDC	31.2 VDC
CH60: 156.300 MHz	0.447 μV	0.447 μV	0.447 μV
CH16: 156.800 MHz	0.473 μV	0.473 μV	0.473 μV
CH28: 162.000 MHz	0.437 μV	0.437 μV	0.437 μV

**4 PHOTOGRAPHS TO REVEAL EQUIPMENT CONSTRUCTION AND LAYOUT (FCC
Rule Part 2.1033)**

(See separate cover. (Furuno Labotech document no. FLI10-04-024 dated 1 September 2004.))

5 DESCRIPTION OF CIRCUITRY AND DEVICES (FCC Rule Part 2.1033)

5.1 Function of Each Semiconductor or Active Device

(1) Transceiver unit FM-8800S

PANEL Board: 05P0772

<u>Symbol</u>	<u>Component</u>	<u>Type</u>	<u>Function</u>
Q1	Transistor	DTD143EKT146	Switching
Q2	Transistor	DTD143EKT146	Switching
Q3	Transistor	DTD143EKT146	Switching
Q4	Transistor	DTD143EKT146	Switching
U1	IC	TA48M033F-TE16L	3.3V 3-terminal regulator
U2	IC	M5218AFP-600C	OP amp

CPU Board: 05P0773

<u>Symbol</u>	<u>Component</u>	<u>Type</u>	<u>Function</u>
Q2	Transistor	2SK3022-00L	Driver
Q4	Transistor	DTC114EKAT146	Switching
Q5	Transistor	DTC114EKAT146	Switching
Q6	Transistor	DTC114EKAT146	Switching
Q7	Transistor	DTC114EKAT146	Switching
Q8	Transistor	2SC3123	Regulation
Q10	Transistor	2SC3123	Buffer Amp
Q11	Transistor	DTC114EKAT146	Switching
Q12	Transistor	DTC114EKAT146	Switching
Q13	Transistor	DTC114EKAT146	Switching
Q14	Transistor	DTC114EKAT146	Switching
Q15	Transistor	DTC114EKAT146	Switching
U1	IC	SN74LVCC4245APWR	CENTRONICS IF
U2	IC	SN74LVCC4245APWR	CENTRONICS IF
U3	IC	TC74LCX04FT-EL	INVERTER
U4	IC	M5218AFP-600C	AF amp
U5	IC	M5218AFP-600C	AF amp
U6	IC	NJM386M-T1	AF amp
U7	IC	TC74HC595AF	8bits Shift Register
U8	IC	TC74HC595AF	8bits Shift Register
U9	IC	M5218AFP-600C	OP amp
U10	IC	AK4543	CODEC
U11	IC	M5218AFP-600C	OP amp
U12	IC	TDA2003H	AF amp
U13	IC	LTC1480CS8	Line Transmitter
U14	IC	LTC1480CS8	Line Transmitter
U15	IC	PC400	Photo Coupler
U16	IC	M5218AFP-600C	OP amp
U17	IC	AK4528VF	CODEC
U18	IC	M5218AFP-600C	2nd.IF Amp
U19	IC	TC74LCX32FT-EL	OR
U20	IC	ADSP2186NBST-320	DSP
U21	IC	TC74VHC165FT-EL	P/S Converter
U22	IC	TC4W53FU-TE12L	SW&2nd.IF Amp

<u>Symbol</u>	<u>Component</u>	<u>Type</u>	<u>Function</u>
U23	IC	NJM2904M-T1	OP amp
U24	IC	TC74VHC165FT-EL	P/S Converter
U25	IC	AD9834BRU-REEL7	DDS
U26	IC	SI-8501L	DC/DC Converter
U27	IC	TA48M033F-TE16L	3.3V 3-terminal regulator
U28	IC	TA48M033F-TE16L	3.3V 3-terminal regulator
U29	IC	AT28BV256-20SC	EEPROM
U30	IC	HD64F2377VFQ33V	CPU
U31	IC	IC41LV16100S-50T	DRAM
U32	IC	TC74LCX04FT-EL	INVERTER
U33	IC	TC74VHC74FT-EL	FLIP-FLOP
U34	IC	M51957BFP C61J	System Reset
U35	IC	TC7S08F-TE85L	AND
U36	IC	S1D13704F00A	LCD Controller
U37	IC	TC74VHCU04FT-EL	INVERTER
U38	IC	TC74VHC161FT-EL	Counter
U39	IC	TC74VHC161FT-EL	Counter
U40	IC	TC74VHC74FT-EL	FLIP-FLOP
U41	IC	TC7S08F-TE85L	AND
U42	IC	M5218AFP-600C	MIC amp
U43	IC	TA4001F-TE85L	

TX / RX Board: 05P0774

<u>Symbol</u>	<u>Component</u>	<u>Type</u>	<u>Function</u>
Q1	Transistor	2SK3074-TE12L	Driver
Q2	Transistor	2SA1213-Y-TE12L	APC
Q3	Transistor	DTC114EKAT146	Switching
Q4	Transistor	DTA114EKAT146	Switching
Q5	Transistor	2SC3356(M)-T1B	TX Driver
Q6	Transistor	PMBFJ310	1st.IF Amp
Q7	Transistor	2SC3356(M)-T1B	RF Amp
Q8	Transistor	DTC114EKAT146	Switching
Q9	Transistor	DTC114EKAT146	Switching
Q10	Transistor	2SC2712-Y-TE85L	APC
Q11	Transistor	DTC114EKAT146	Switching
Q12	Transistor	DTA114EKAT146	Switching
Q13	Transistor	2SC3356(M)-T1B	VCO Buffer Amp
Q14	Transistor	2SC3356(M)-T1B	VCO OSC
Q15	Transistor	PMBFJ310	VCO Buffer Amp
Q16	Transistor	DTC114EKAT146	Switching
Q17	Transistor	2SA1213-Y-TE12L	Switching
Q18	Transistor	DTC114EKAT146	Switching
Q20	Transistor	2SC3123	Buffer Amp
Q21	Transistor	2SA1037AKT146R	Switching
Q101	Transistor	PMBFJ310	Buffer Amp
Q102	Transistor	2SC2712-Y-TE85L	APC
Q111	Transistor	2SK882-GR-TE85L	1st.IF Amp
Q112	Transistor	2SC2712-Y-TE85L	AGC
Q113	Transistor	2SC2712-Y-TE85L	AGC
Q114	Transistor	2SC3324-B-TE85L	2nd.IF Amp

<u>Symbol</u>	<u>Component</u>	<u>Type</u>	<u>Function</u>
Q115	Transistor	DTC114EKAT146	Switching
U1	IC	RA35H1516M	TX Amp
U2	IC	DCS3D20-0157	CM Coupler
U3	IC	NJM2904M-T1	APC
U4	IC	NJM2904M-T1	APC
U5	IC	TA4001F-TE85L	Buffer Amp
U7	IC	UPC2745TB-E3	VCO Buffer Amp
U8	IC	UPC2745TB-E3	VCO Buffer Amp
U9	IC	TA48L033F-TE12L	3.3V 3-terminal regulator
U10	IC	TA4001F-TE85L	Buffer Amp
U11	IC	TC7SHU04F-TE85L	Buffer Amp
U12	IC	LMX2353TMX	PLL IC
U13	IC	LM60CIM3	Temperature Sensor

CH70 RX Board: 05P0775

<u>Symbol</u>	<u>Component</u>	<u>Type</u>	<u>Function</u>
Q1	Transistor	2SC3356(M)-T1B	Buffer Amp
Q2	Transistor	PMBFJ310	1st.IF Amp
Q3	Transistor	2SC3356(M)-T1B	RF Amp
Q4	Transistor	2SK882-GR-TE85L	1st.IF Amp
Q7	Transistor	2SC3324-B-TE85L	2nd.IF Amp
Q8	Transistor	2SK882-GR-TE85L	Xtal OSC
U2	IC	TA48L033F-TE12L	3.3V 3-terminal regulator

POWER Board: 05P0776

<u>Symbol</u>	<u>Component</u>	<u>Type</u>	<u>Function</u>
Q1	Transistor	2SD1271A-P	Regulation
Q2	Transistor	2SD2185S-TX	Switching
Q3	Transistor	DTC114EKAT146	Current Amp
U1	IC	CBS2002415-T	DC/DC Converter
U2	IC	M51958BFP-600D	Under-Voltage Protection

5.2 Description of the circuits employed for suppression of spurious radiation, for limiting or shaping the control pulse, and for limiting or controlling power

(1) Block Description

(1.1) General

The FM-8800S operates from 24 VDC power supply and consists of seven boards as showed below. It can be combined with the RB-8800, RB-8810, DMC-5, wing handset, navigation equipment (NMEA input and output), and printer.

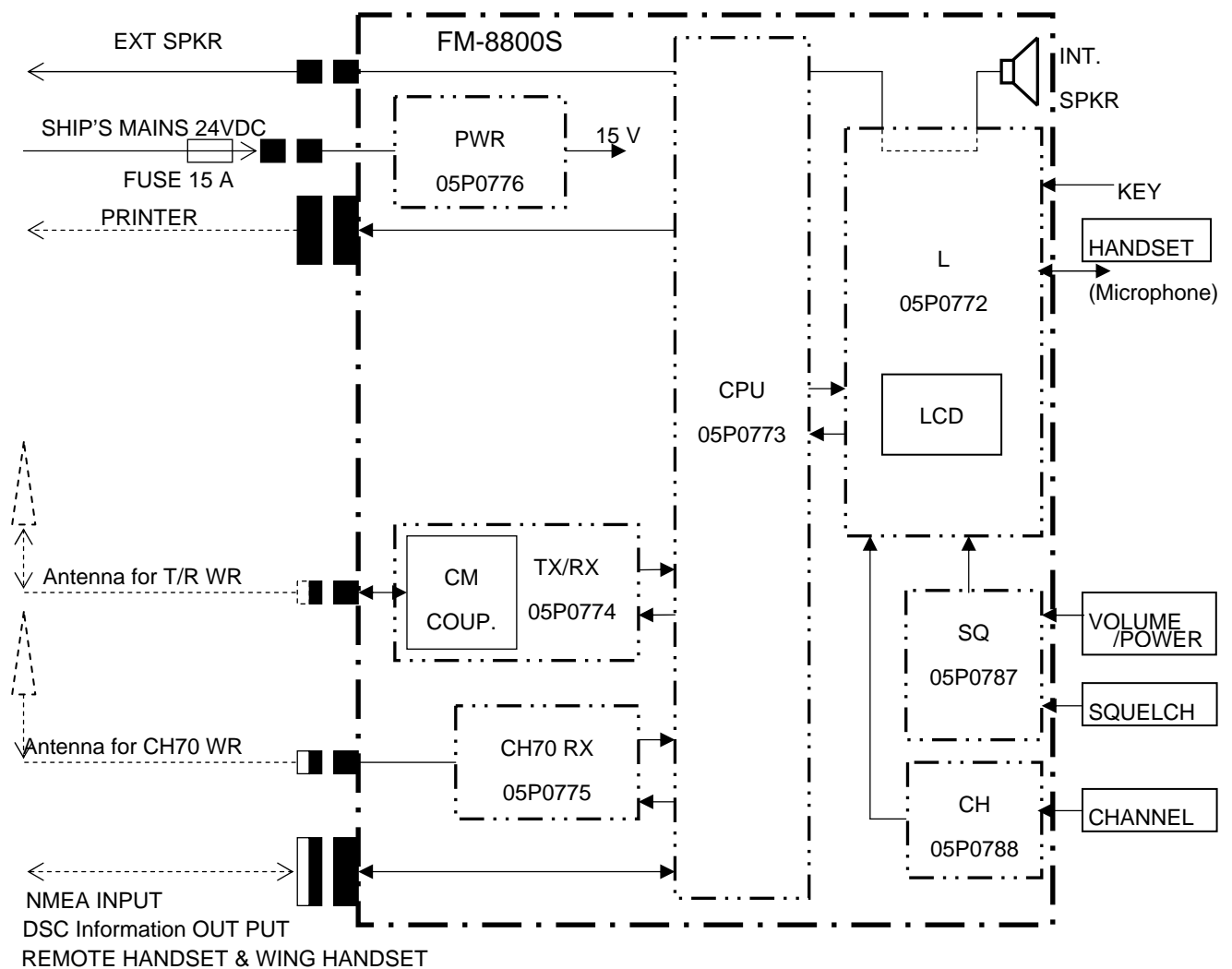

GENERAL BLOCK DIAGRAM

(1.2) Function of major circuits

Table (1.2) Function of major circuits

Block name	Outline
PANEL (05P0772)	Power switch ON/OFF, Internal speaker volume control, Squelch control, Display on LCD, Control by Key-entry.
CPU (05P0773)	Consists of CPU, DSP, and its peripheral circuits. FM modulation, Demodulation process, Analog interface with radio part, DSC, system control of radio communication and I/O interface are done.
TX/RX (05P0774)	FM modulated signal 45 MHz is input from CPU Block, and converted into a transmitting frequency and power-amplified. RF Power module U1 (RA35H1516M) amplifies the signal into 25 W. VHF receiving signal is converted into 37.5 kHz IF signal which is demodulated into voice signals and tone signals at CPU Block.
CH70 RX (05P0775)	DSC receiving signal is converted to 37.5 kHz IF signal. The receiving frequency is CH70: 156.525 MHz .
PWR (05P0776)	24 VDC input is distributed to each PCB after converting to 15 VDC by the switching regulator.
SQ (05P0787)	Squelch level is adjustable automatically and manually.
CH (05P0788)	Power switch ON/OFF, Internal speaker volume control and Key control.

(2) Transmission Signal Flow
(2.1) Transmission Signal Flow

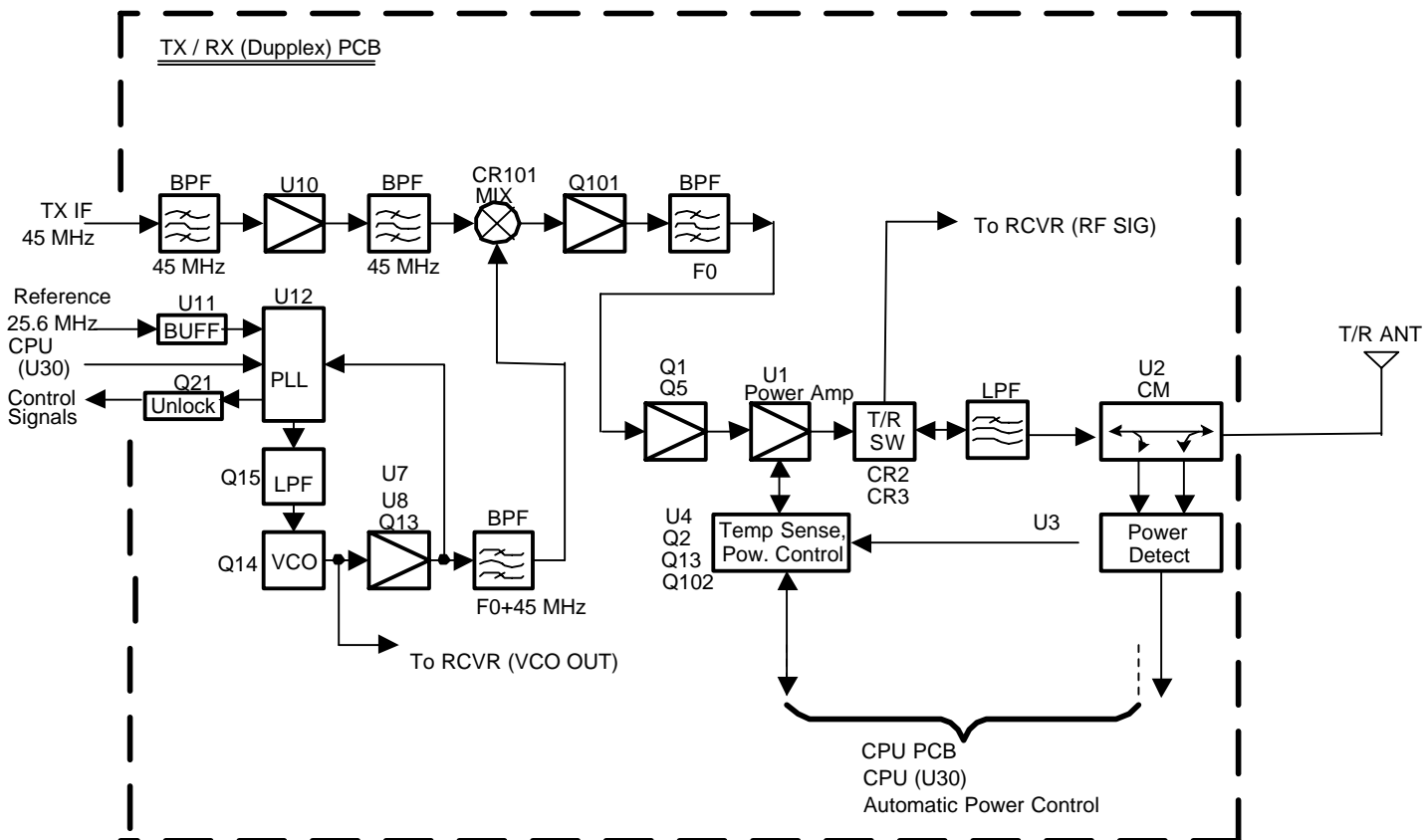
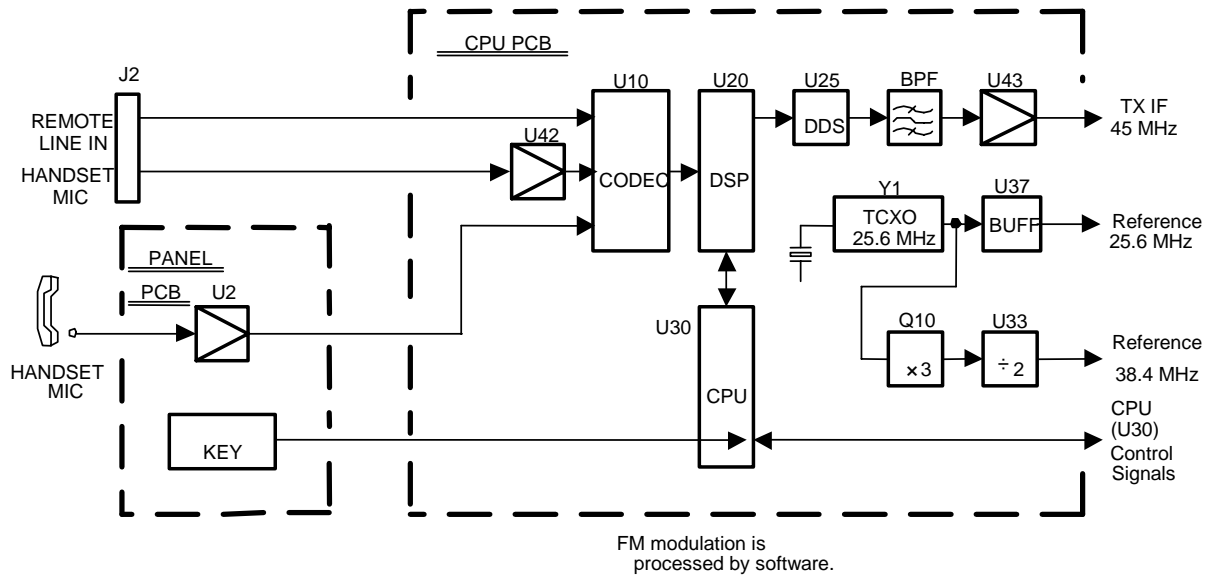

Fig. (2.1-1) TRANSMISSION SIGNAL FLOW

Voice signal coming from the microphone (standard modulation: 600 Ω , -49 dBm) is input to U10 Codec (AK4543) of CPU Board(05P0773) after amplified by 20 dB at U2 OP.AMP (M5218AFP) of PANEL Board (05P0772).

The signal is sampled by the sampling frequency of 8.33 kHz at U10 Codec, and FM-modulated at U20 DSP (ADSP2186NBST) after converted to digital signals.

Amplitude information of the signal is changed into the frequency ones by the software.

The details about the software processing are shown in Subclause (2.1.1).

The frequency information is of 45 MHz FM-modulated wave at U25 DDS (AD9834BRU) of CPU Board (05P0773), and is amplified up to 50 Ω , -28 dBm at U43 RF AMP (μ PC1675G) after passing the B.P.F made up of L/C. Finally the TX IF signal is output to TX/RX Board (05P0774).

The spurious components included in the transmission modulated signal coming from TX IF signal is reduced at FL1 B.P.F (Passband width: \pm 10 kHz, Stopband attenuation: more than 80 dB at \pm 900 kHz) of TX/RX Board (05P0774).

The signal is mixed at CR101 (1SS271) with the 1st local oscillated frequency (200.000 MHz to 206.475 MHz) produced by the PLL circuit, and is converted to the frequency of 155.000 MHz to 161.475 MHz.

The next stage B.P.F is made of L/C circuit, reducing the spurious components produced by the frequency conversion. U1 is of HPA module (Gain: 30 dB or more, Attenuation of 2nd harmonics: 40 dB or more) and holds 25 W output.

The output of HPA is of spurious attenuated by an LPF (Cut-off freq.: 195 MHz, Attenuation of harmonics: 60 dB or more) made of the L/C circuit, and is connected to VHF ANT terminal via U2: CM coupler.

Y1: 25.6 MHz of CPU Board (05P0773) is a reference oscillator (TCXO) of the PLL circuit of TX/RX Board (05P0774), and has an accuracy of \pm 2.5 ppm at -25°C to +70°C, maintaining the VHF transmitting frequency tolerance within \pm 400 Hz.

2.1.1 Explanation of signal processing by software

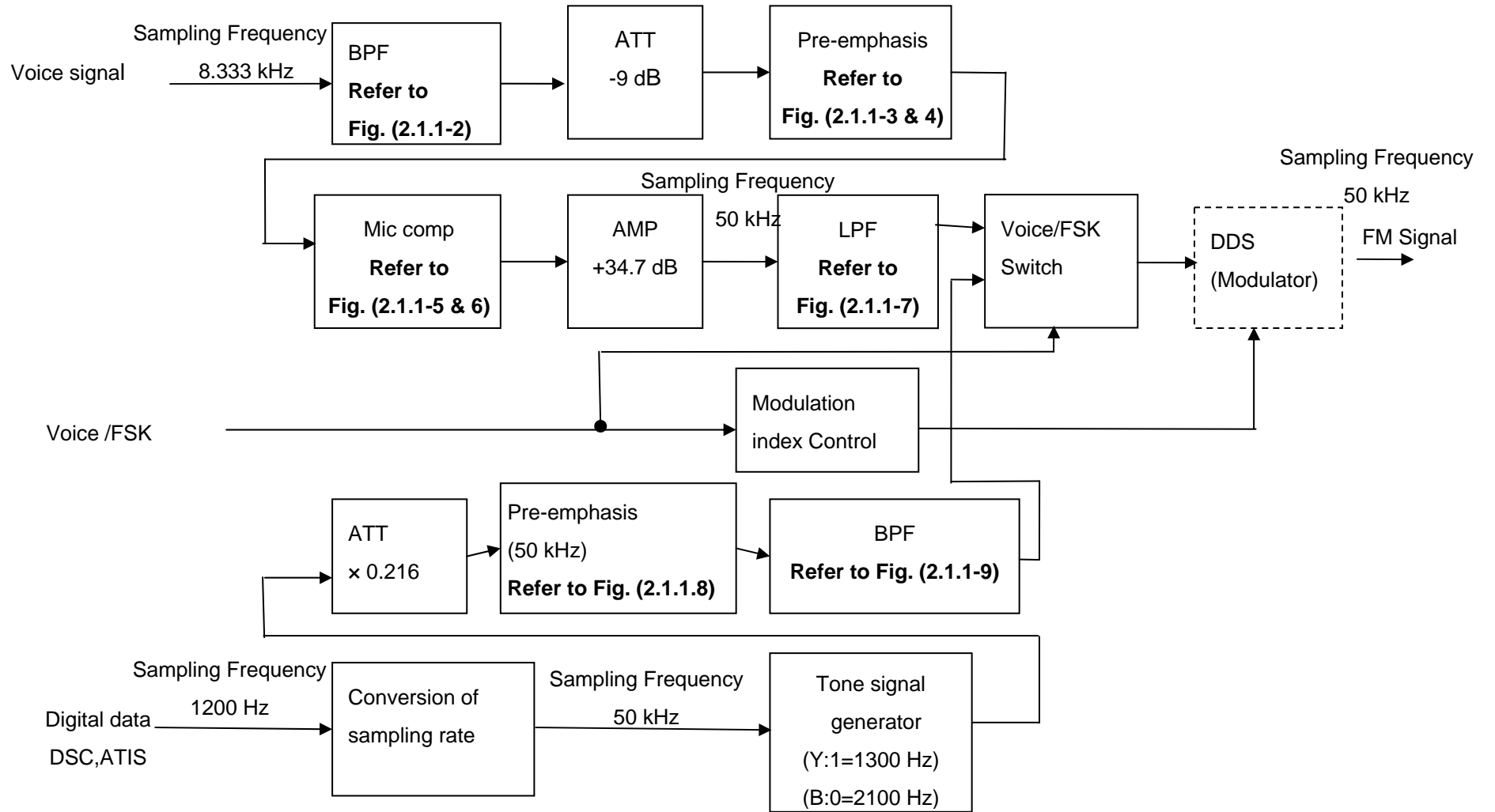

Fig. (2.1.1-1) The outline of Signal processing by software

FM modulation is performed by the software processing at U20 DSP (ADSP2186NBST). Its outline is indicated in Fig. (2.1.1-1).

The voice signal converted into the digital signal is passed to B.P.F. (Fig. (2.1.1-2)) removing unnecessary harmonics, and then goes into the filter having pre-emphasis characteristics (Fig. (2.1.1-3)).

Fig. (2.1.1-4) indicates the measurement data of pre-emphasis characteristics.

The voice signal is compressed by a mic-compressor and controlled not to exceed a frequency shift of 5 kHz. See Fig. (2.1.1-5) and Fig. (2.1.1-6).

Further, L.P.F (Fig. (2.1.1-7)) compresses the frequency shift of 3 kHz or more, and attenuates the element of leaked power to the adjacent channel. U25 DDS (AD9834BRU) generates FM-modulated signal of direct 45 MHz.

On the other hand, DSC, ATIS signal is produced with 1300 Hz and 2100 Hz tone signals at DSP sine-converting the digital data produced at U30 CPU (HD64F2377) of CPU Board (05P0773).

Tone signals pass the pre-emphasis filter shown in Fig. (2.1.1-8).

Likewise the voice signal, B.P.F compresses the frequency shift of 3 kHz or more, and attenuates the element of leaked power to the adjacent channel. FM modulated signal of direct 45 MHz by DDS is generated. See Fig. (2.1.1-9).

Modulation by DDS varies the modulation index depending on the type of signals to be modulated. DSC signals are controlled with the modulation index to be 2, while ATIS signals are to be 1.

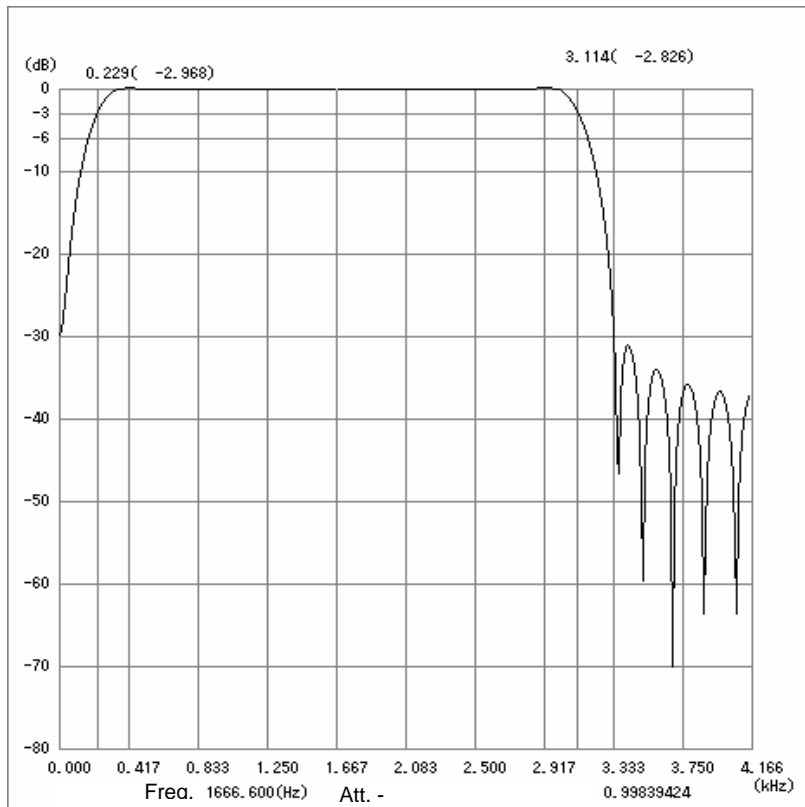

Band pass filter
 Sample freq.: 8333.0(Hz)
 Stop limit freq.: 0.0(Hz)
 Pass limit freq.: 350.0(Hz)
 Pass limit freq.: 3000.0(Hz)
 Stop limit freq.: 3350.0(Hz)
 Stop reduction : 31.0(dB)
 Coeff. tap : 41
 Coeff. format : Q15

Fig. (2.1.1-2) The characteristics of BPF

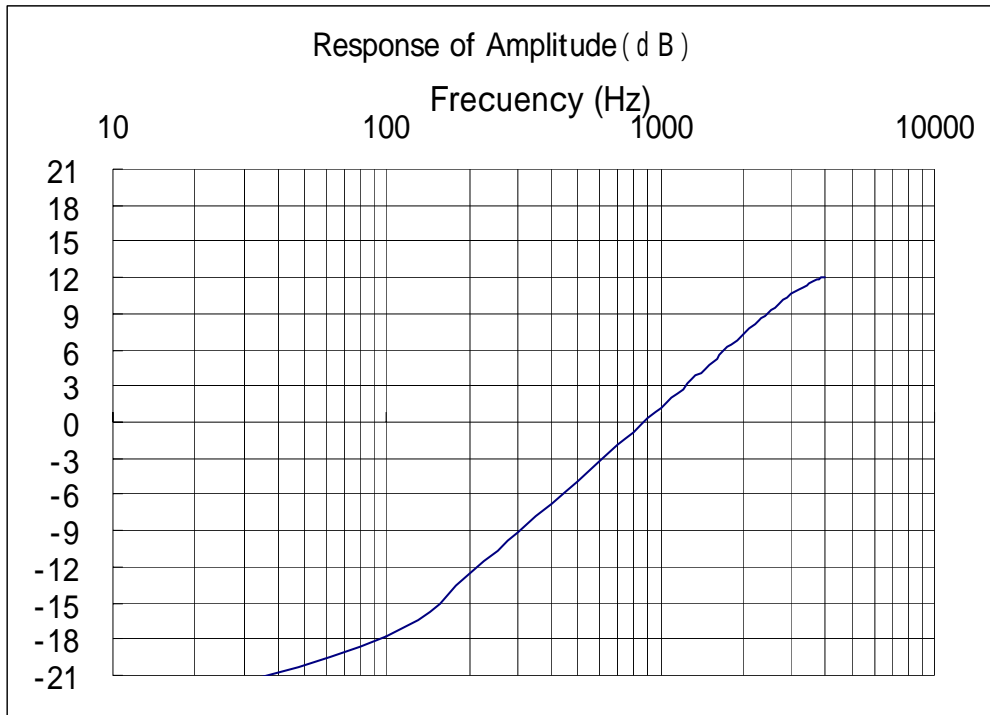

Fig. (2.1.1-3) The characteristics of Pre-emphasis

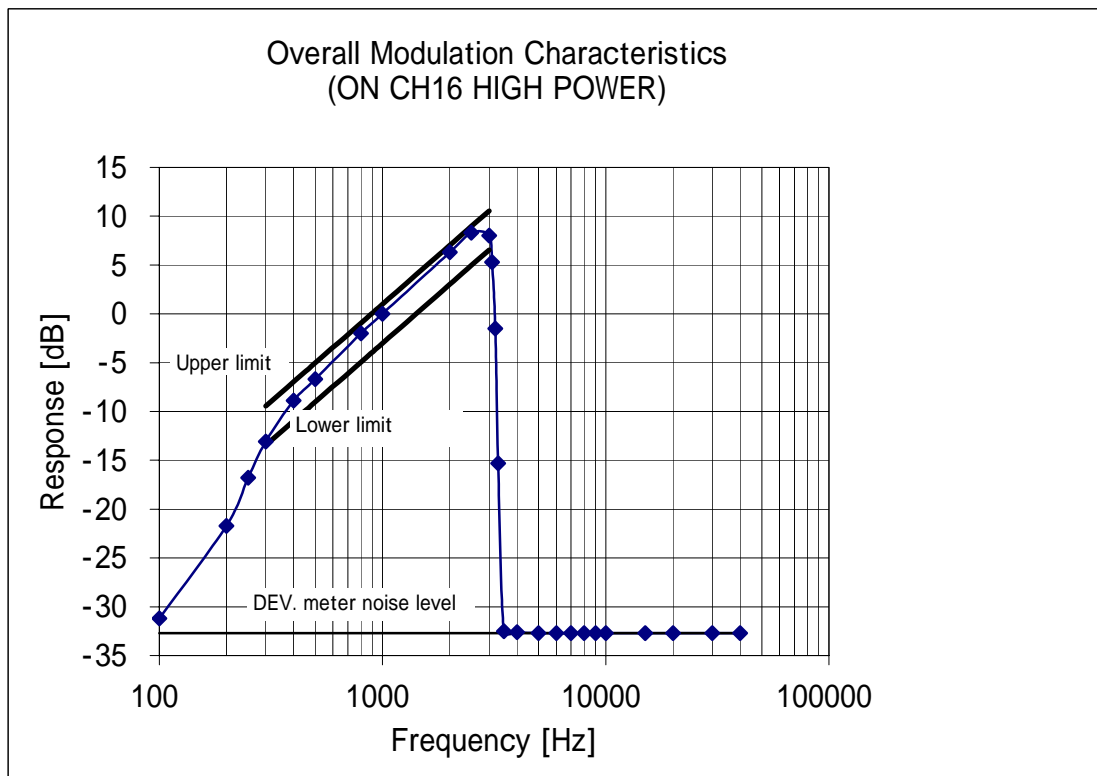

Fig. (2.1.1-4) The characteristics of Pre-emphasis (Survey data)

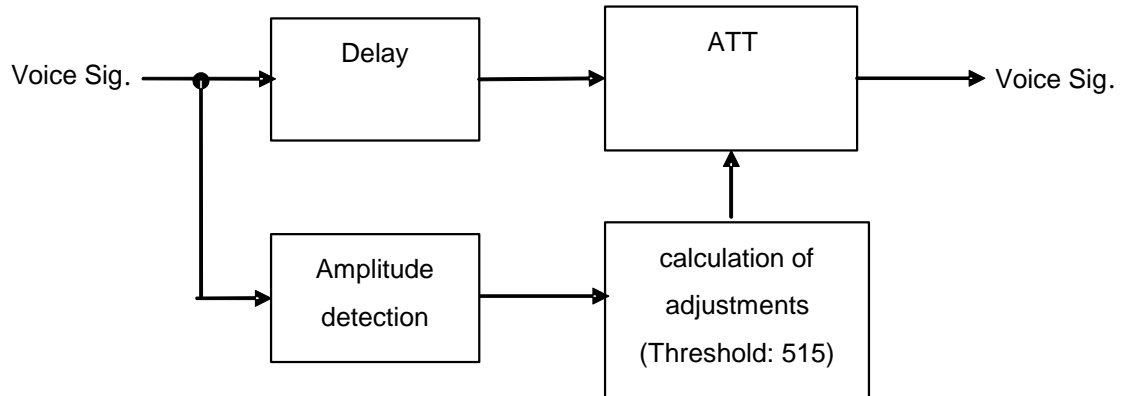

Fig. 2.1.1-5 Details of Mic comp

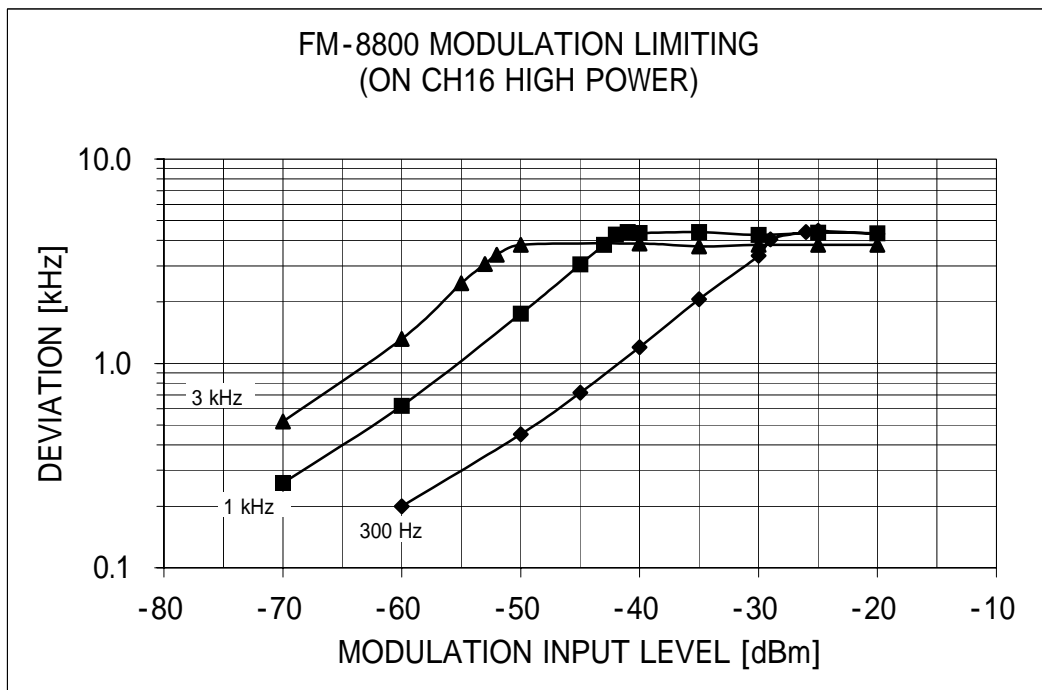
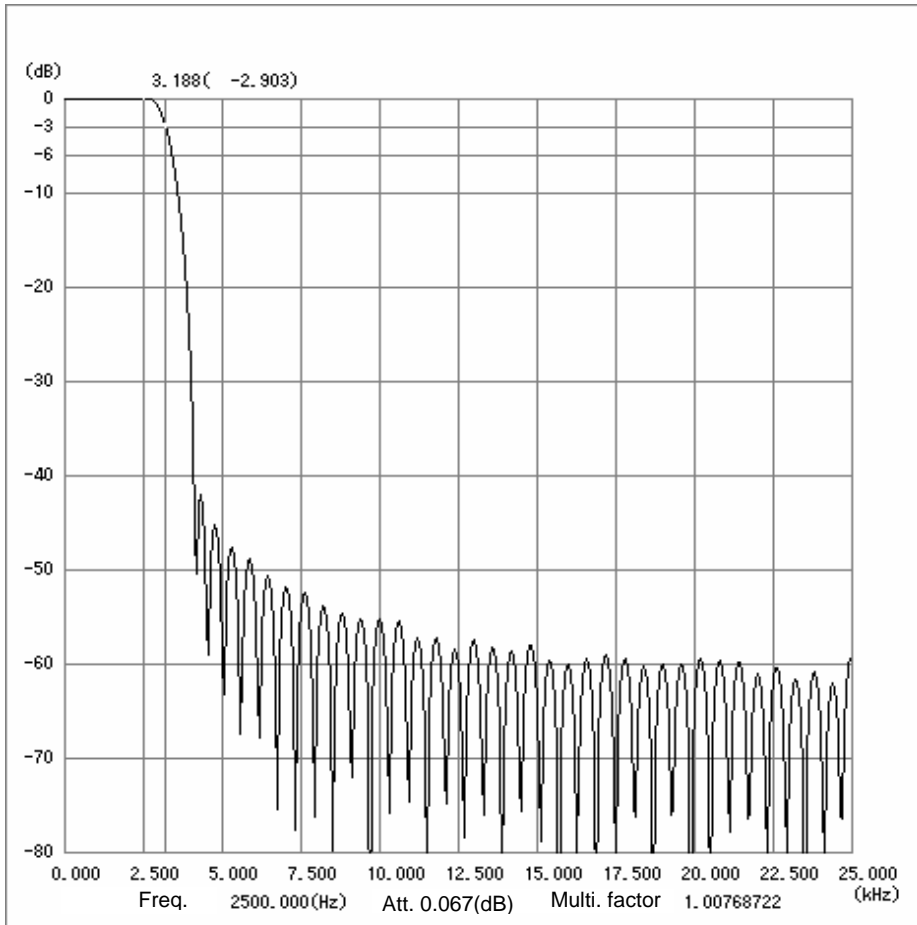

Fig. 2.1.1-6 The characteristics of Modulation Limiting (Survey data)



Low pass filter
 Sample freq.: 50000.0 (Hz)
 Pass limit freq.: 2700.0 (Hz)
 Stop limit freq.: 4100.0 (Hz)
 Stop reduction: 40.9 (dB)
 Coeff. Tap : 83
 Coeff. format : Q17
 Coeff. mag. : 1.50

Fig. 2.1.1-7 The characteristics of LPF

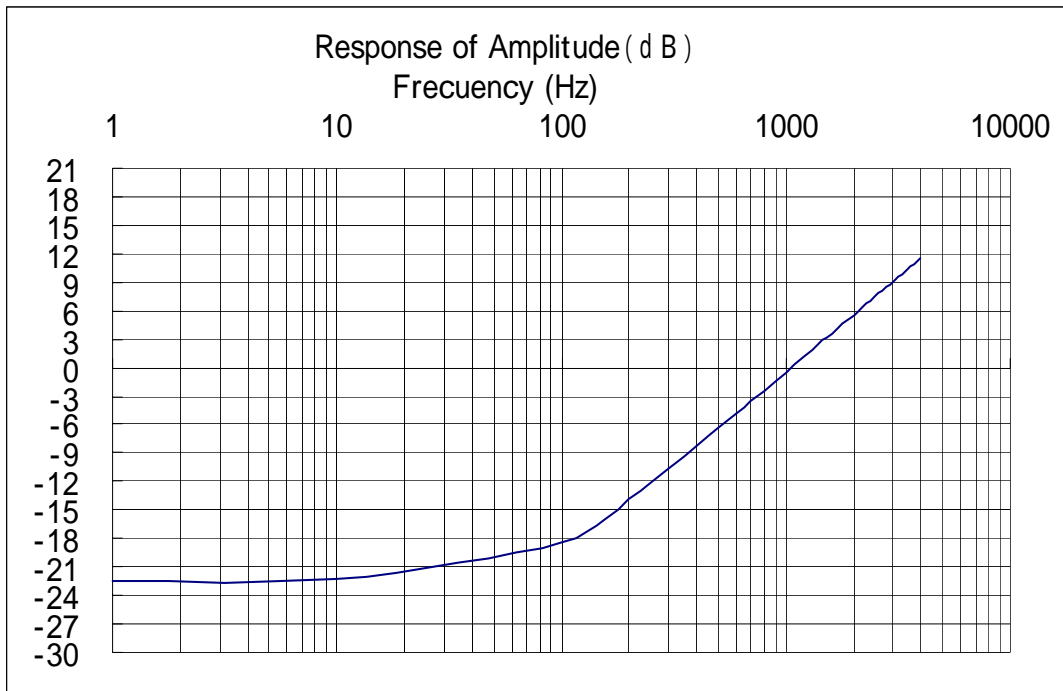
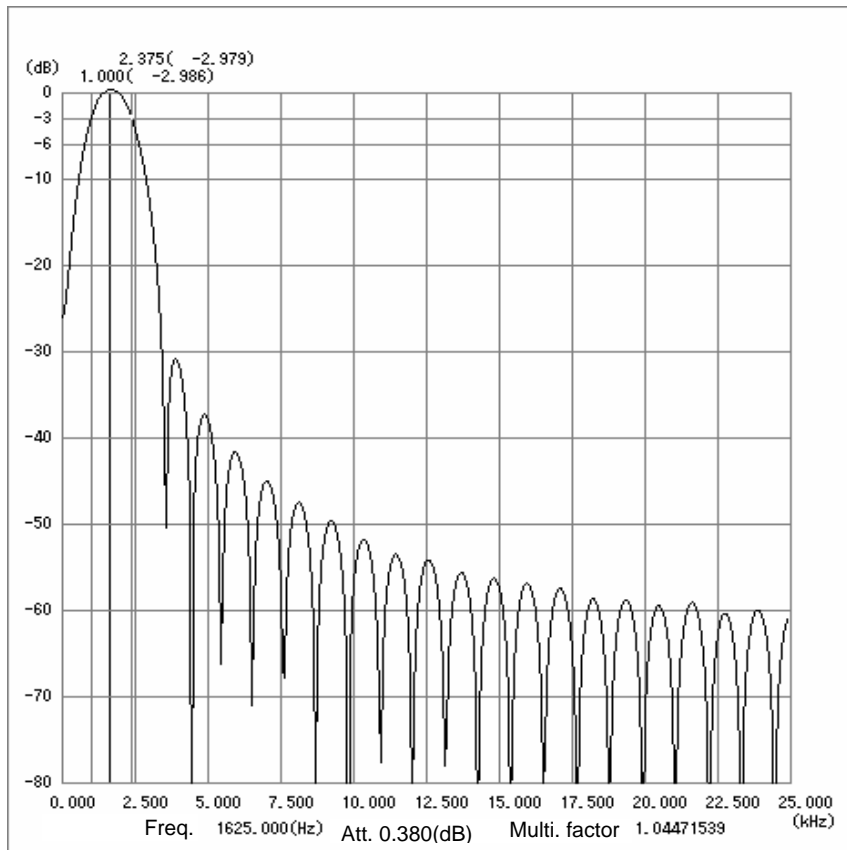

Fig. 2.1.1-8 The characteristics of Pre-emphasis (50 kHz)



Band pass filter
 Sample freq. : 50000.0 (Hz)
 Stop limit freq. : 0.0(Hz)
 Pass limit freq. : 1500.0 (Hz)
 Pass limit freq. : 1900.0 (Hz)
 Stop limit freq. : 3400.0 (Hz)
 Stop reduction : 26.0 (dB)
 Coeff. tap : 43
 Coeff. format : Q15
 Coeff. mag. : 1.00

Fig. (2.1.1-9) The characteristics of BPF

(3) Reception Signal Flow on Simplex channel

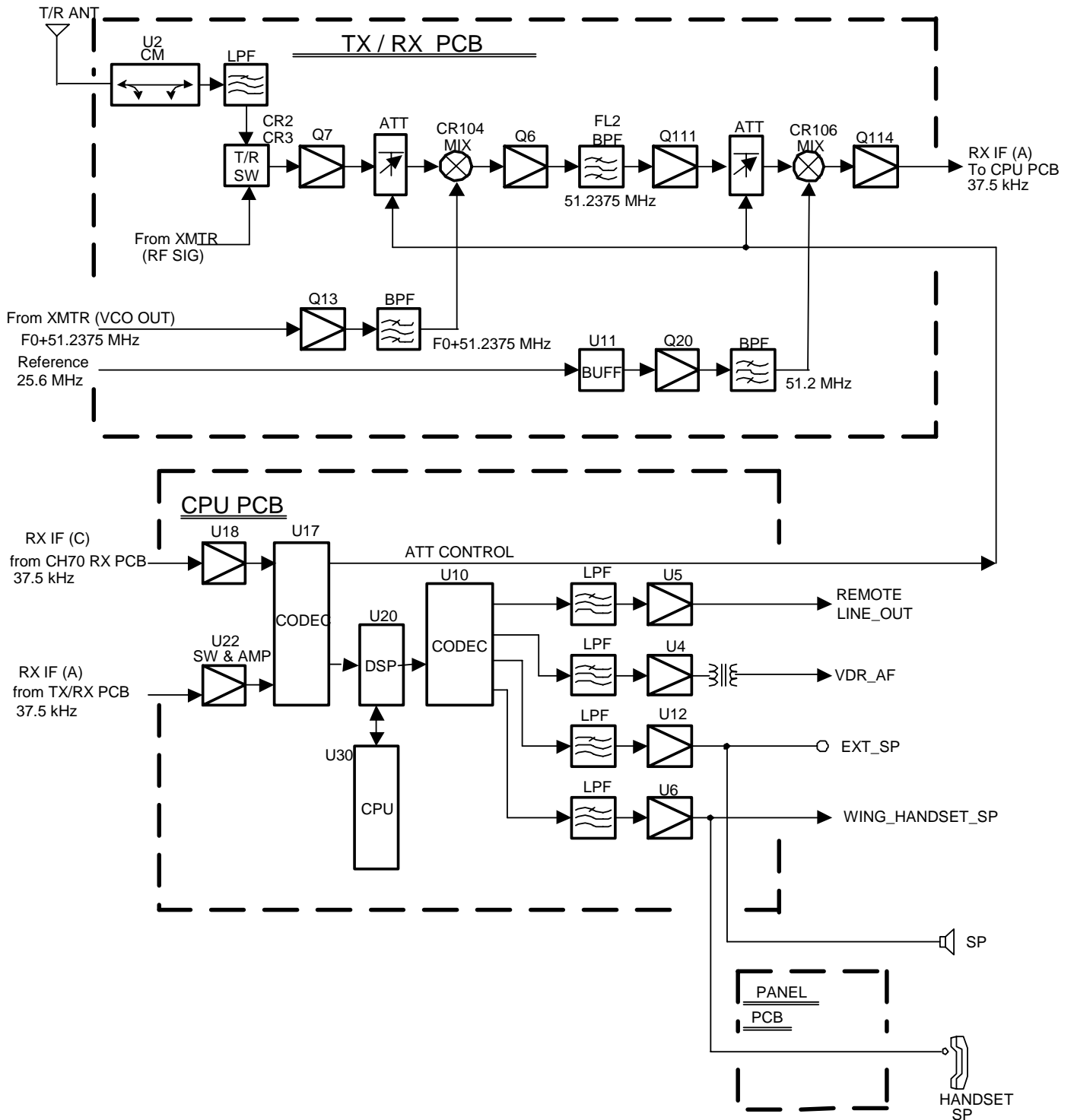

Fig. (3-1) VHF Reception Signal Flow

VHF RX signal reaches the 1st mixer circuit CR104 (1SS271) after passing a Directional coupler, Duplexer, LPF and T/R switching and amplified by Q7 at TX/RX Board (05P0774). At CR104, RX signal of 150 MHz band and 1st local oscillation freq. of 206 to 210 MHz produced by PLL circuit are mixed to convert to 1st IF frequency of 51.2375 MHz. The BPF, FL2 for 1st IF stage has a pass-bandwidth of ± 7.5 KHz attenuating the spurious components created by the frequency conversion. The RX 1st IF signal comes to 2nd mixer circuit CR106 (1SS271) after amplified at Q111. At CR106, the RX 1st IF signal is converted to 2nd IF signal of 37.5 kHz by means of the 2 multiplied local oscillation of 25.6 MHz coming from CPU Board (05P0773). Then, it is converted to the digital signal by U17 CODEC (AK4528VF) of CPU Board (05P0773), and FM-demodulated by the software.

(4) CH70 Reception Signal Flow

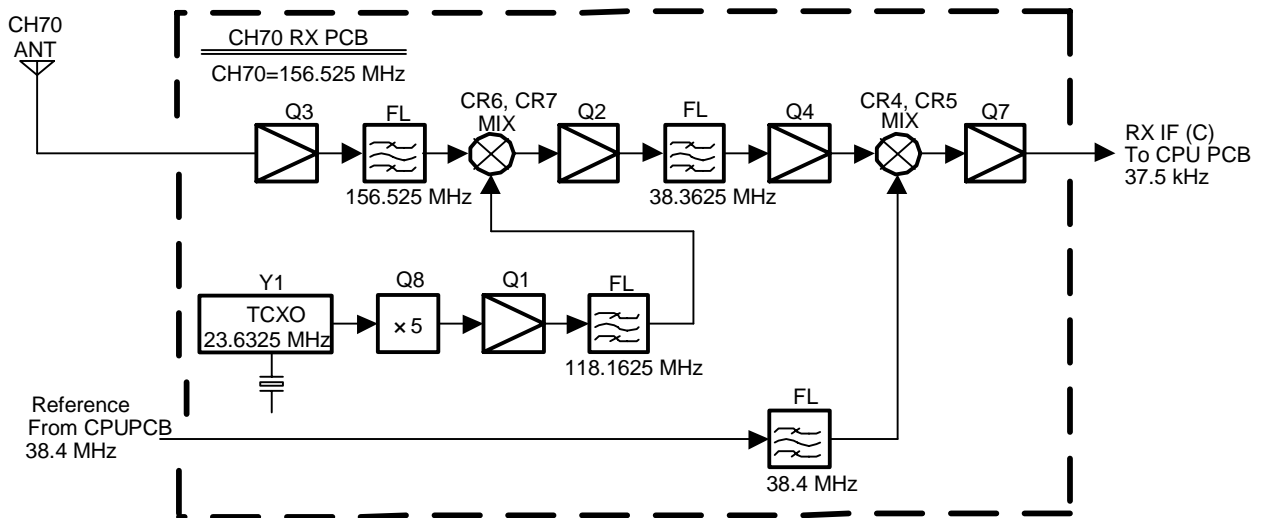
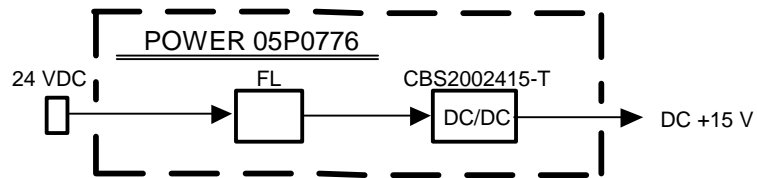

Fig. (4-1) CH70 Reception Signal Flow

CH70 RX Board (05P0775) produces 1st local oscillation frequency of 118.1625 MHz by multiplying 23.6325 MHz by 5 produced by the crystal oscillator Y1(TCXO). The RX 1st IF signal of 38.3625 MHz is converted to 2nd IF signal of 37.5 kHz by 2nd local oscillation frequency 38.4 MHz which is dividing (25.6 MHz x 3) by half at CPU (05P0773). Then, after the amplification, it is converted to the digital signal by U17 CODEC (AK4528VF) of CPU Board (05P0773), and demodulated to the DSC signal by the software.

(5) Power Supply Circuit

This is a switching power supply with the oscillation frequency of 370 kHz producing the output voltage of 15 VDC.

6 OPERATOR'S MANUAL INCLU. CIRCUIT DIAGRAMS (FCC Rule Part 2.1033)

(See separate cover.)