

Pub No. TI-1674
Date: March, 1998

FURUNO®

TECHNICAL INFORMATION

**TEST REPORT ON THE PERFORMANCE OF
MARINE RADAR**

MODEL FR-7252

FURUNO ELECTRIC CO., LTD.
NISHINOMIYA CITY, JAPAN

March, 13 , 1998

All data herein contained is true and correct to my best knowledge.

A handwritten signature in black ink, reading "T. Yoshihara" with a long horizontal flourish extending to the right.

T. Yoshihara
Manager
Radar Development Section
Development Management Division
FURUNO ELECTRIC CO., LTD.

Personal History

Born: January 29, 1944

Graduated: Osaka University
Electric Engineering Faculty

Occupation: Joined FURUNO ELECTRIC CO., LTD. in April 1967, since then engaged
in the development of radar equipment.

******* CONTENTS *******

1	GENERAL INFORMATION	1
2	IDENTIFICATION OF EQUIPMENT	11
3	MODULATION CHARACTERISTICS	12
4	OCCUPIED BANDWIDTH	17
5	EMISSION LIMITATIONS	19
6	SPURIOUS EMISSIONS AT ANTENNA TERMINALS	21
7	FIELD STRENGTH OF SPURIOUS RADIATION	34
8	FREQUENCY STABILITY WITH VARIATION OF AMBIENT TEMPERATURE AND POWER SUPPLY	43
9	PHOTOGRAPHS TO REVEAL EQUIPMENT CONSTRUCTION AND LAYOUT	45
10	TECHNICAL DESCRIPTION OF EQUIPMENT	
10.1	Function of Each Semiconductor or Active Device	52
10.2	Circuit Description	57
11	SUPPRESSION OF INTERFERENCE ABOARD SHIPS	59
12	OPERATOR'S MANUAL INCL. CIRCUIT DIAGRAMS	(Separate cover)

1 GENERAL INFORMATION

1.1 General

- (a) Manufacturer: Furuno Electric Co., Ltd., Japan
- (b) Model: FR-7252 (Serial No.3375-0002)
- (c) Primary Function: Search, navigation and anticollision
- (d) Maximum Range from Antenna: 96 nautical miles
- (e) Minimum Range from Antenna: 25 meters on 0.25 mile range
- (f) Frequency Range: Fixed frequency, X-band
- (g) Power Supply: 21.6 - 41.6 VDC

1.2 Transmitter

- (a) Assignable Frequency for Shipborne Radar: Between 9300 and 9500 MHz (FCC 83.404)
- (b) Type of R.F. Generator Magnetron Type: M1458F or MG5436
Peak Output Power: 25 kW nominal
- (c) Magnetron Ratings
Center frequency of Magnetron: 9410 MHz
Tolerances
Manufacturing: M1458F ±30MHz MG5436 ±30MHz
Pulling: 23 MHz 23 MHz
Tolerance for 20fC change temperature variation: 5 MHz 5 MHz
- (d) Transmitting Frequency Variation with respect to ambient temperature (Power supply variation -15%, +25%): 9412.8 MHz at -20 °C
9410.1 MHz at +20 °C
9407.2 MHz at +50 °C
(Details on separate sheet)
- (e) Guard Band

Guard Band is specified to be equal to $1.5/t$ MHz, where "t" is the pulselength in microseconds. See para (h).

(f) Frequency Limits

From (d) and (e), the frequency limits are:

Upper Limit: $9412.8 + 18.75 = 9431.55$ MHz (at -20°C)
Lower Limit: $9407.2 - 18.75 = 9388.45$ MHz (at $+50^{\circ}\text{C}$)

It is verified that the radar applied for the type acceptance is well within the assignable frequency range of 9300 thru 9500 MHz. (FCC 83.404)

(g) Occupied Bandwidth: Occupied bandwidth data is shown in paragraph 4 according to FCC Rule 2.989.

(h) Microwave Characteristics:

The peak voltage was determined, using the TEKTRONIX Divider having a ratio of 1000 to 1 and the KIKUSUI COS6100A Oscilloscope. The current pulse was viewed across the PEARSON ELECTRONICS Wide Band Current Transformer Model 2100, Output Volts Per Amp 1.00.

	<u>Short</u>	<u>Middle</u>	<u>Long_1</u>	<u>Long_2</u>	<u>Long_3</u>
Test Range (nm):	0.25	2	36	48	96
NOMINAL VALUES					
Output pulselength:	0.08 μs	0.3 μs	0.8 μs	0.8 μs	0.8 μs
P.R.R.:	2100 Hz	1200 Hz	600 Hz	550 Hz	500 Hz
Duty cycle:	0.000168	0.00036	0.00048	0.00044	0.0004
Guard Band (MHz):	18.75	5.00	1.88	1.88	1.88

MEASUREMENTS

Magnetron input pulse voltage was measured at the cathode using the KIKUSUI COS6100A Oscilloscope, and TEKTRONIX Divider, ratio 1000 to 1.

	<u>Short</u>	<u>Middle</u>	<u>Long_1</u>	<u>Long_2</u>	<u>Long_3</u>
Directional Coupler Att:	40.67 dB	40.67 dB	40.67 dB	40.67 dB	40.67 dB
Magnetron Input Voltage:	8.5 kV	8.2 kV	8.2 kV	8.2 kV	8.2 kV
Pulselength (50% amplitude):	0.240 μs	0.400 μs	0.960 μs	0.960 μs	0.960 μs
Rise time (10 - 90% amplitude):	0.075 μs	0.070 μs	0.070 μs	0.070 μs	0.070 μs

Decay time (90 - 10 % amplitude):	0.460 μ s	0.400 μ s	0.320 μ s	0.320 μ s	0.320 μ s
---	---------------	---------------	---------------	---------------	---------------

Magnetron input pulse current was observed across the PEARSON ELECTRONICS Wide Band Current Transformer Model 2100, Output Volts per Amp. 1.00.

	<u>Short</u>	<u>Middle</u>	<u>Long_1</u>	<u>Long_2</u>	<u>Long_3</u>
Magnetron Input Current:	6.0 A	6.6 A	7.5 A	7.5 A	7.5 A
Pulselength (50% amplitude):	0.104 μ s	0.260 μ s	0.800 μ s	0.800 μ s	0.800 μ s
Rise time (10 - 90% amplitude):	0.080 μ s	0.150 μ s	0.240 μ s	0.240 μ s	0.240 μ s
Decay time (90 - 10 % amplitude):	0.120 μ s	0.145 μ s	0.200 μ s	0.200 μ s	0.200 μ s

The R.F. envelope of the magnetron output pulse was measured using a diode and the KIKUSUI COS6100A Oscilloscope with the following results:

	<u>Short</u>	<u>Middle</u>	<u>Long_1</u>	<u>Long_2</u>	<u>Long_3</u>
Pulselength (-3 dB points):	0.113 μ s	0.265 μ s	0.780 μ s	0.780 μ s	0.780 μ s
Rise time (10 - 90% amplitude):	0.015 μ s	0.050 μ s	0.060 μ s	0.060 μ s	0.060 μ s
Decay time (90 - 10 % amplitude):	0.090 μ s	0.100 μ s	0.130 μ s	0.130 μ s	0.130 μ s
Reference Level:	49.18 dB	50.86 dB	52.91 dB	52.40 dB	52.05 dB

Estimated efficiency of the R.F. Generator (magnetron) was determined by the following measurements and calculation. Power output from Magnetron was measured using the 40.67 dB Directional Coupler, the Hewlett-Packard Power Meter Type 436A, and the KIKUSUI COS6100A Oscilloscope.

	<u>Short</u>	<u>Middle</u>	<u>Long_1</u>	<u>Long_2</u>	<u>Long_3</u>
Test Range (nm):	0.25	2	36	48	96
P.R.R.:	2130.7 Hz	1209.3 Hz	621.4 Hz	552.4 Hz	508.5 Hz
Duty cycle:	0.000240	0.000320	0.000484	0.000430	0.000396
Magnetron input (AV)	12.279W	17.344W	29.809W	26.499W	24.393W

Magnetron input (peak)	51000W	54120W	61500W	61500W	61500W
Power meter reading:	0.356 mW	0.524mW	0.839mW	0.746mW	0.688mW
Magnetron Output (Av):	4.154W	6.114W	9.790W	8.704W	8.028W
Magnetron Output (Peak):	17252W	19079W	20197W	20202W	20240W
Magnetron efficiency:	33.83%	35.25%	32.84%	32.85%	32.91%
Peak Power Input to RF Generator:			57924W		
Estimated Efficiency of RF Generator:			33.54%		

(i) Radar Pulse Spectrum (FCC ,2.997)

Measured by the HEWLETT-PACKARD Spectrum Analyzer Model 71210C.

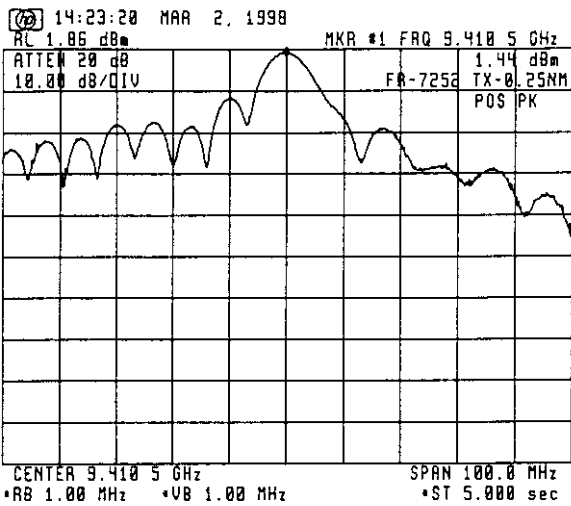

Short Pulse

Center Frequency: 9410.5MHz
Vertical Scale: 10 dB/div.
Horizontal Scale: 10 MHz/div.

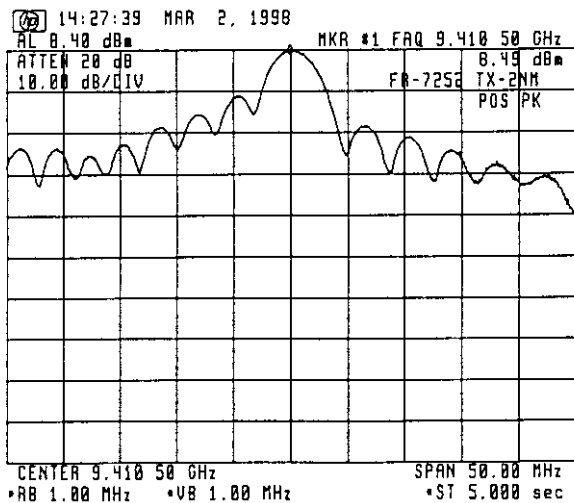

Middle Pulse

Center Frequency: 9410.50MHz
Vertical Scale: 10 dB/div.
Horizontal Scale: 5 MHz/div.

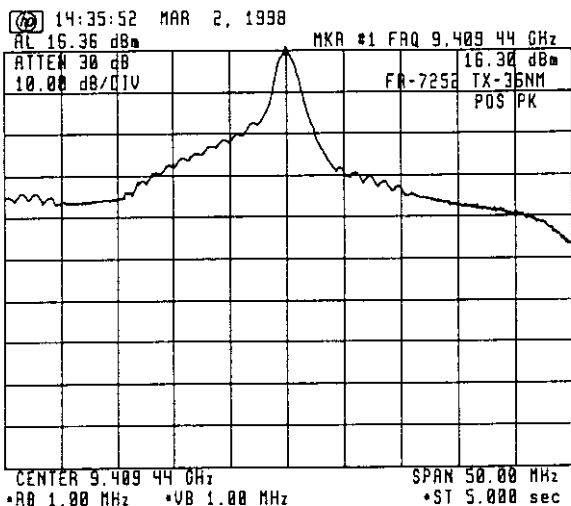

Long 1 Pulse

Center Frequency: 9409.44 MHz
Vertical Scale: 10 dB/div.
Horizontal Scale: 5 MHz/div.

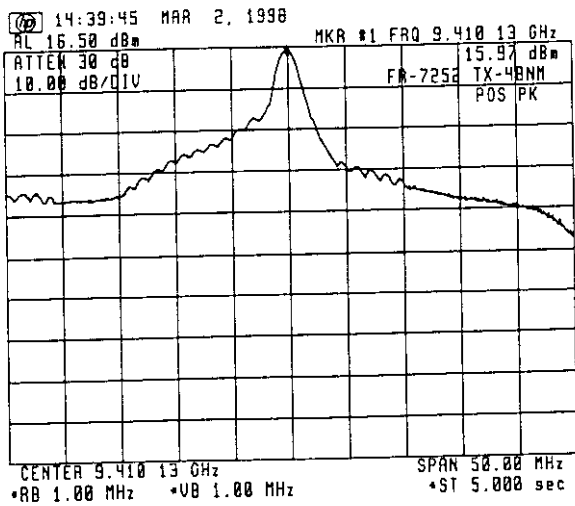

Long 2 Pulse

Center Frequency: 9410.13 MHz
 Vertical Scale: 10 dB/div.
 Horizontal Scale: 5 MHz/div.

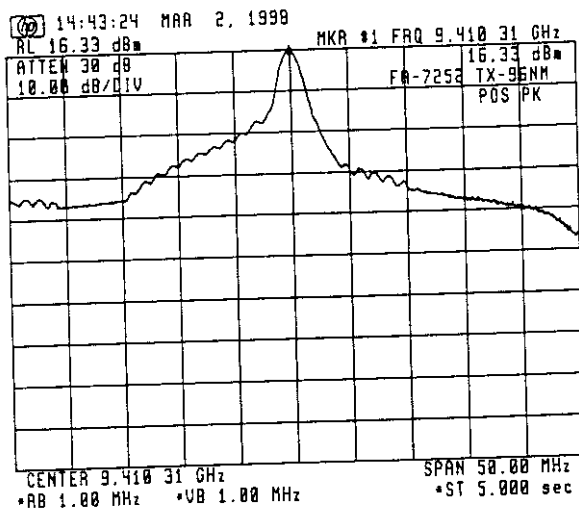

Long 3 Pulse

Center Frequency: 9410.31 MHz
 Vertical Scale: 10 dB/div.
 Horizontal Scale: 5 MHz/div.

1.3 Modulator

- (a) FET Type: 2SK1464
 Trigger voltage: Approx. +20 V DC

1.4 Receiver

- (a) Passband: R.F. Stage: 100 MHz
 I.F. Stages: 7 MHz for 0.08/0.3/0.8 μ s P/L
 Video Amp.: 3 MHz for 0.8 μ s P/L
 10 MHz for 0.08/0.3 μ s P/L
- (b) Gain (overall): Sufficient to cause limiting, approximately 130 dB
- (c) Overall noise figure in dB: 6 dB measured using Noise Figure Meter H.P. Type 8970A, 346B
- (d) Video Output Voltage: 0.7 V positive across 75 ohms
- (e) Features Provided: Sensitivity Time Controls (Anti-clutter Sea), Fast Time Constant
- (f) If receiver is tunable, describe method of adjusting frequency: Adjustment of tuning voltage of receiver local oscillator (Automatic)

1.5 Display

- (a) Type: PPI, raster scan
- (b) R.P.M.: 24 rpm (XN12A & XN13A) or 48 rpm (XN12A)
- (c) Size of Indicator Tube: 12" diagonal CRT (effective dia. 180 mm)
- (d) Sweep Linearity: 2 % on all ranges
- (e) Range Scales:

Range	Number of Range Rings	Range Ring Interval
0.125 n.m.	2	0.0625 n.m.
0.25 n.m.	2	0.125 n.m.
0.5 n.m.	4	0.25 n.m.
0.75 n.m.	3	0.25 n.m.
1 n.m.	4	0.25 n.m.
1.5 n.m.	3	0.5 n.m.
2 n.m.	4	0.5 n.m.
3 n.m.	3	1 n.m.
4 n.m.	4	1 n.m.
6 n.m.	3	2 n.m.
8 n.m.	4	2 n.m.

12 n.m.	4	3 n.m.
16 n.m.	4	4 n.m.
24 n.m.	4	6 n.m.
36 n.m.	3	12 n.m.
48 n.m.	4	12 n.m.
64 n.m.	4	16 n.m.
72 n.m.	4	18 n.m.
96 n.m.	4	24n.m.

- (f) Range Ring Accuracy: Better than 0.9 % of maximum scale in use or 8 m, whichever is the greater
- (g) Overall Bearing Accuracy from Scanner to Display: Better than 1°
- (h) Target Plot Facility: Simulated afterglow in low shade
- (i) Heading Indicator: Provided, automatic alignment
- (j) True Bearing Indicator: Provided

1.6 Antenna

- (a) Antenna Rotation ON-OFF Switch: Not provided
- (b) Reflector: Slotted waveguide array, XN12A; 120 cm
XN13A; 180 cm
- (c) Type of Beam: Vertical fan
- | (d) Beam Width (between half-power points) | Radiator Type | |
|--|---------------|-------|
| | XN12A | XN13A |
| Horizontal: | 1.9° | 1.2° |
| Vertical: | 22° | 22° |
- (e) Polarization: Horizontal
- | (f) Antenna Gain: | | |
|-------------------|-------|-------|
| | XN12A | XN13A |
| | 28 dB | 30 dB |
- (g) Attenuation of Major Side Lobes with respect to main beam:
(*): ±20° for radiator type XN12A
- | | Radiator Type | |
|-----------------|---------------|-------|
| | XN12A | XN13A |
| Within ±10(*): | 24 dB | 24 dB |
| Outside ±10(*): | 30 dB | 30 dB |
- (h) Scanning (rotating or oscillating): Rotating over 360° continuously clockwise
- | (i) Speed of Rotation: | | |
|------------------------|---------------|--------|
| | XN12A & XN13A | XN12A |
| | 24 rpm | 48 rpm |
- (j) Number of Degrees Scanned: 360°
- (k) Sector Scan: Not provided
- (l) Resolution (on 0.25 n.m. scale)
- | | XN12A | XN13A |
|----------|--------------|--------------|
| Range: | 20 meters | |
| Bearing: | XN12A : 1.9° | XN13A : 1.4° |

- (m) Type of Transmission System: Contained in scanner unit
- (n) Rated Loss of Transmission System per hundred feet: None. Transmission path is only in the antenna scanner unit.

1.7 Line Power Supply Requirements

- (a) Input Voltage: 21.6 - 41.6 VDC
- (b) Maximum Power Drain: Approx. 150 W

1.8 Functional Controls

Range selector	Tune (manual) 3)	EBL offset
INDEX LINE	Anti-clutter auto	Power Switch
STC control	Gain control	Panel dimmer 3)
Heading mark off	Echo stretch	MENU
Guard zone set/Audio alarm off	Range ring brilliance 3)	Noise rejector on/off 3)
Interference rejector 3)	STBY/TX	Trackball (VRM,EBL,GUARD)
VRM on/off	Off-center (SHIFT)	A/C Rain control
Range set 3)	Zoom	EBL on/off
Echo Trail	Brilliance	TRU/REL 2)3)
Navigation on/off 1)2)	Mark Brilliance 3)	Watchman 3)
Range ring on/off	character Brilliance 3)	Dead sector 3)
ARPA FUNCTION (option)		

- 1) Valid when interfaced with navaid.
- 2) Valid when interfaced with gyrocompass.
- 3) Selected on menu.

1.9 Construction Features

- (a) Does equipment embody replacement units with chassis type assembly: Yes
- (b) Are fuse alarms provided: Fuses are provided.
- (c) State units which are weatherproof: Scanner Unit (IEC IPX6)
- (d) If all units are not housed in a single container, indicate number and give description of individual units.
 - 1 × Display Unit
 - 1 × Scanner Unit
- (e) Approximate Weight of Complete Installation:

Display Unit:	13 kg	
Scanner Unit:	23 kg	(XN12A-RSB-0072/73)
	25 kg	(XN13A-RSB-0072/73)

(f) Approximate space required for installation excluding scanner

Unit	<u>Width</u>	<u>Height</u>	<u>Depth</u>
Display	438 mm	415 mm	435 mm

1.1 Operational Features

(a) Is positive means provided to indicate whether or not the overall operation of the equipment is such that it may be relied upon to provide effective operation in accordance with its primary function:

Magnetron/Xtal checker

(b) Is the equipment for continuous operation:

Yes

(c) Is provision made for operation with shore based radar beacons (RACONS):

Yes

3 MODULATION CHARACTERISTICS (FCC 2.987)

3.1 FET Trigger Pulse

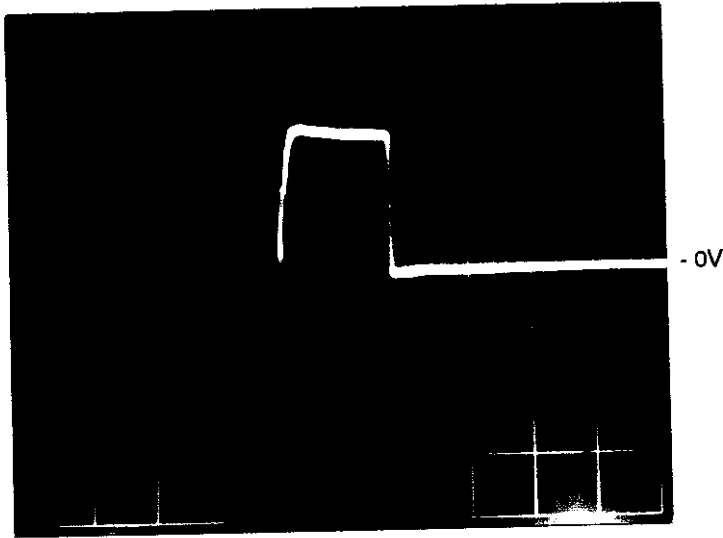

Scale: 10 V/div.
0.5 μ s/div.

Fig. 3.1

Note: FET trigger pulse is common to all ranges.

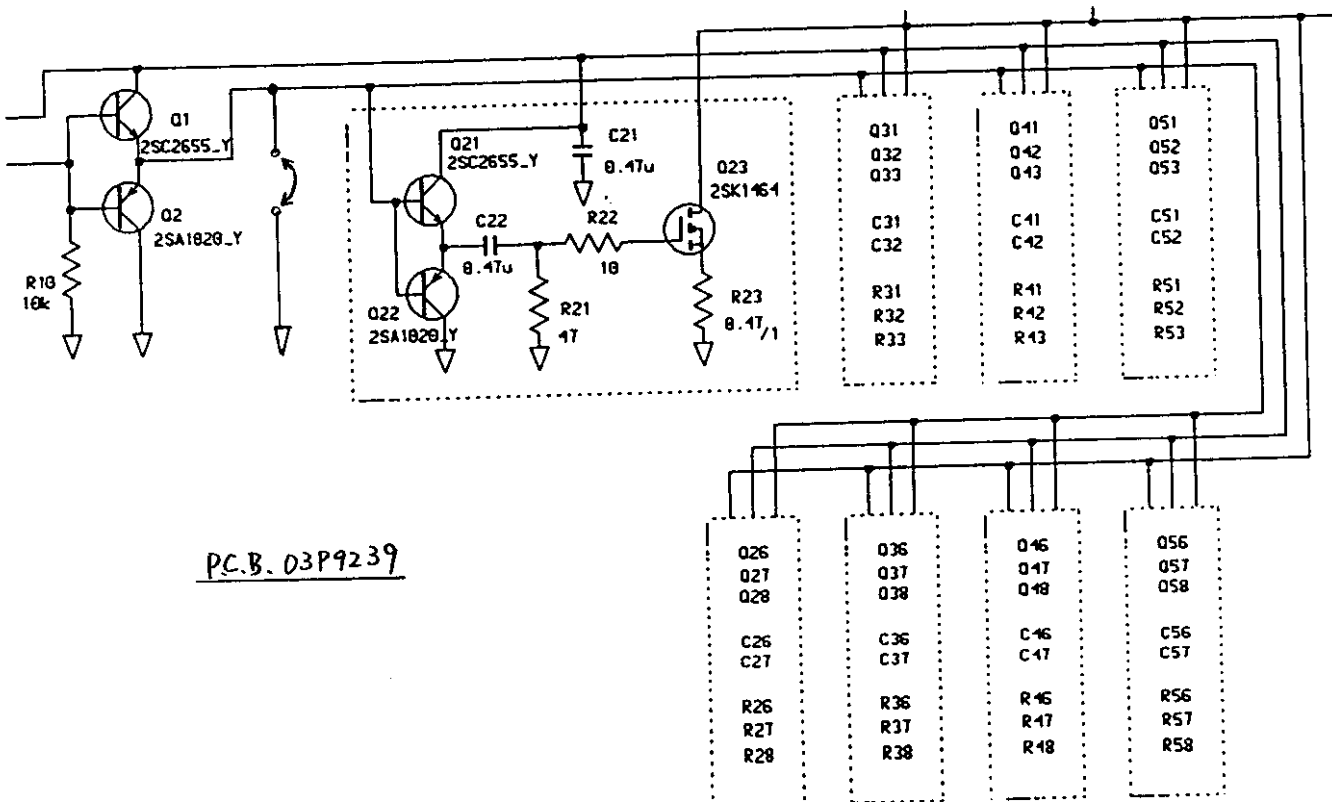

3.2 Trigger Pulse at Magnetron Cathode

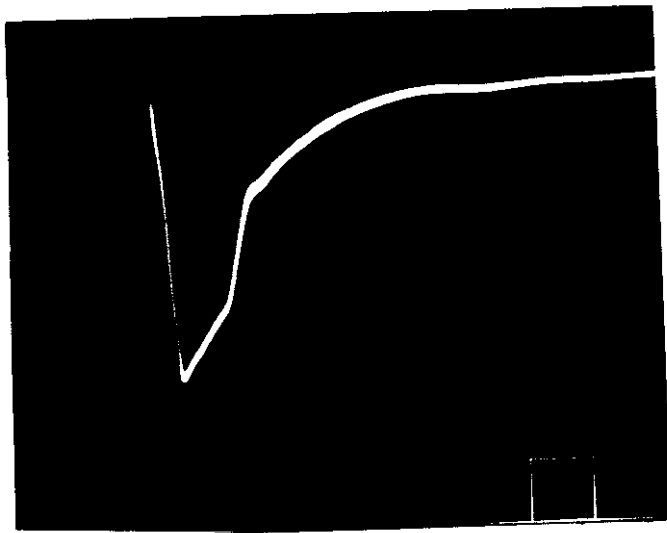

Fig. 3.2

Short Ranges

Scale: 2 kV/div.
0.2 μ s/div.



Fig. 3.3

Middle Ranges

Scale: 2 kV/div.
0.2 μ s/div.

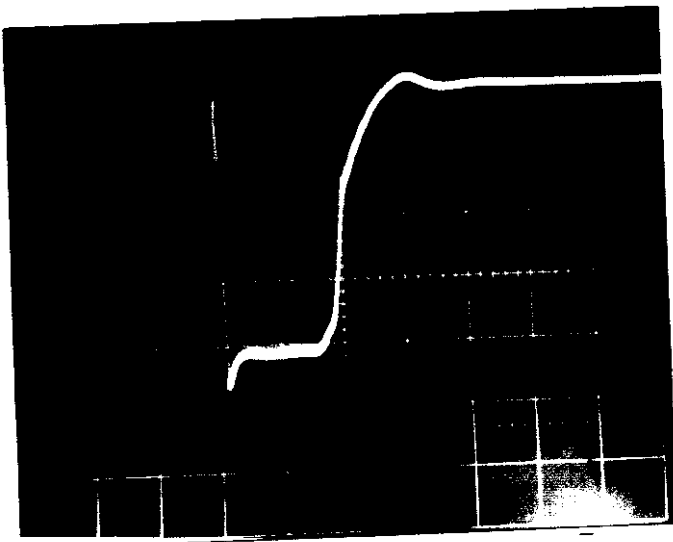

Fig. 3.4

Long 1 Ranges

Scale: 2 kV/div.
0.5 μ s/div.

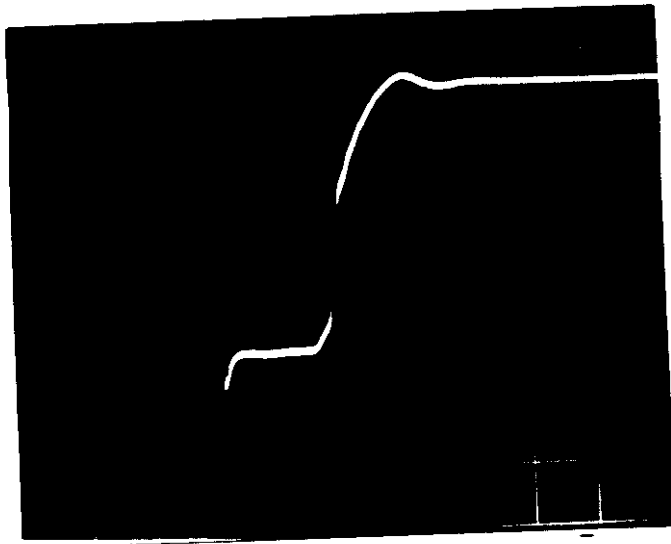

Fig. 3.5

Long 2 Ranges

Scale: 2 kV/div.
0.5 μ s/div.

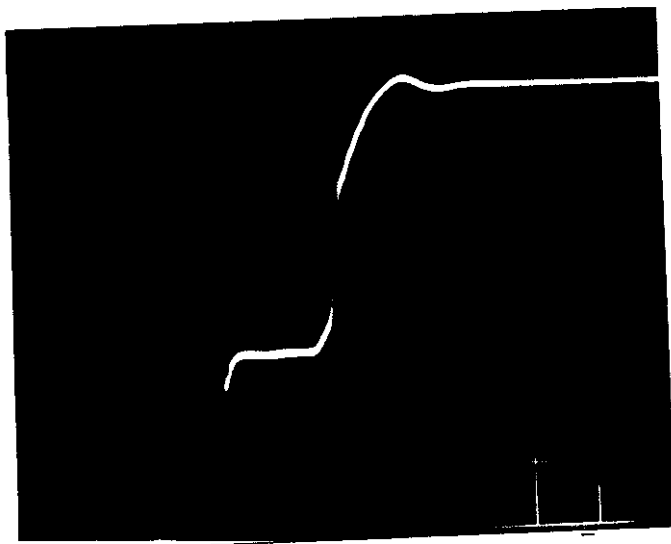

Fig. 3.6

Long 3 Ranges

Scale: 2 kV/div.
0.5 μ s/div.

3.3 Magnetron Output (detected)

Setup for Measurement

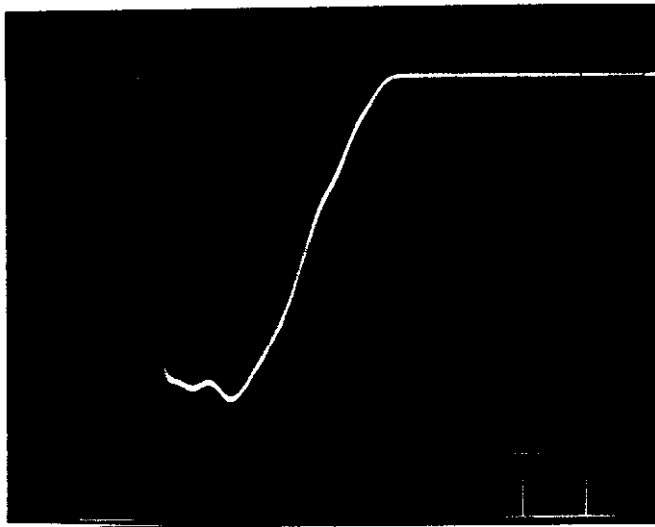
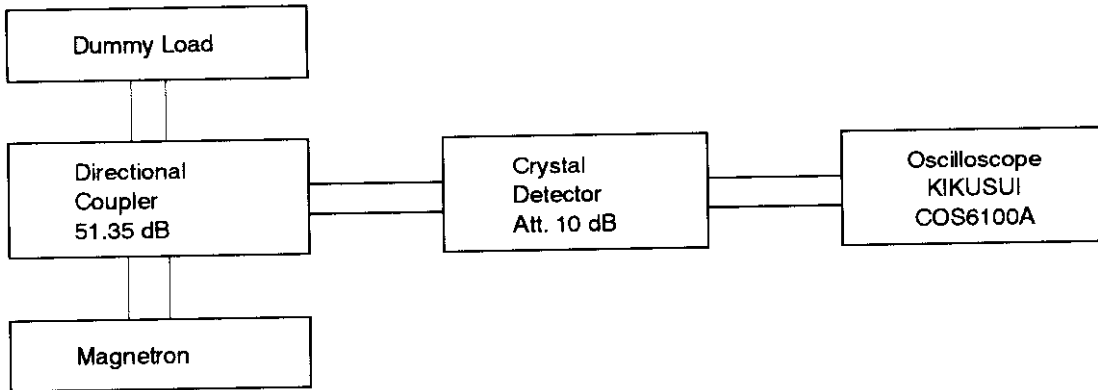

Fig. 3.7

Short Ranges

Scale: 10 mV/div.
0.05 μ s/div.

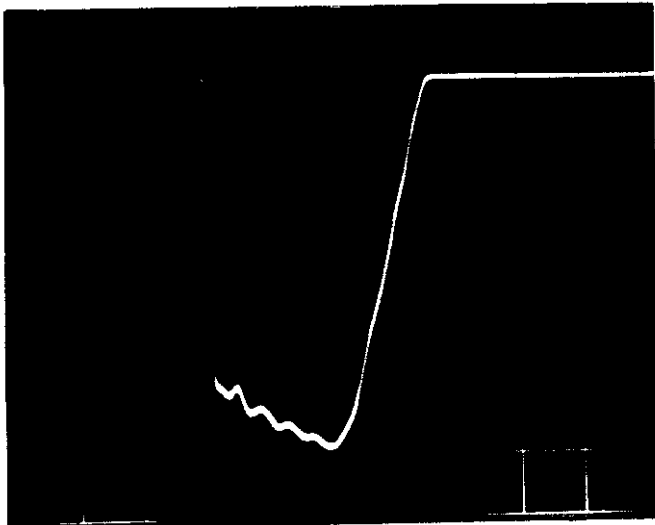

Fig. 3.8

Middle Ranges

Scale: 10 mV/div.
0.1 μ s/div.

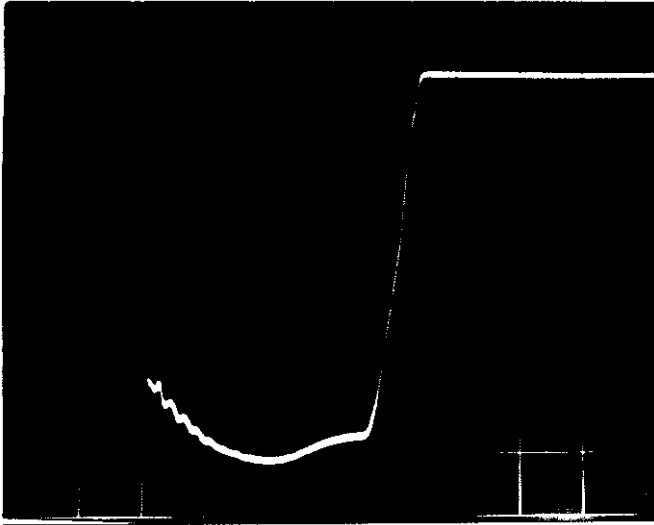

Fig. 3.9

Long 1 Ranges

Scale: 10 mV/div.
0.2 μ s/div.

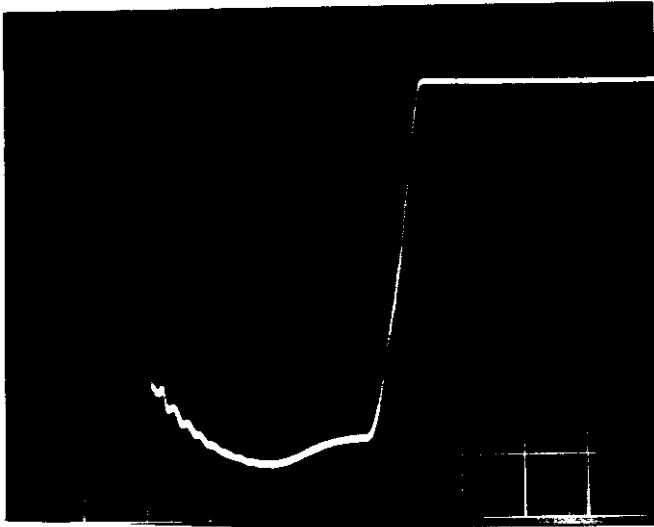

Fig. 3.10

Long 2 Ranges

Scale: 10 mV/div.
0.2 μ s/div.



Fig. 3.11

Long 3 Ranges

Scale: 10 mV/div.
0.2 μ s/div.

4 OCCUPIED BANDWIDTH (FCC 2.989)

4.1 Measuring Method

FCC rule 47 CFR 2.989 requires measurements of the occupied bandwidth which is defined in the same section as "the frequency bandwidth such that, below its lower and above its upper frequency limits, the mean powers radiated are each equal to 0.5 percent of the total mean power radiated by a given emission."

To obtain the occupied bandwidth of the radar transmitter, a special program (program list shown below) was loaded to the Hewlett-Packard spectrum analyzer HP 71210C and run by entering the HP-provided POWER BANDWIDTH calculation command [PWRBW]. The result was automatically displayed on the screen on the spectrum analyzer as:

POWER_BW=----- MHz

```
10      ! HP_71000 DOWNLOAD PROGRAM
20      ASSIGN @Sa TO 71B
30      CLEAR @Sa
40      CALL M_ain(@Sa)
50      LOCAL @Sa
60      END
70      !
80      SUB M_ain(@Sa)
90 M_ain: !
100     CALL Pwr_bw(@Sa)
110     CALL Limit_line(@Sa)
120     !
130     OUTPUT @Sa;"VARDEF K_ey,0;";
140     !
150     OUTPUT @Sa;"FUNCDEF D_LP,^";
160     OUTPUT @Sa;"MOV K_ey,0;";
170     !
180 Main_menu: !
190     OUTPUT @Sa;"REPEAT,^";
200     OUTPUT @Sa;"READMENU K_ey,^";
210     ! location: %Top---Bottom-%
220     OUTPUT @Sa;"^,%Limit line %,^";
230     OUTPUT @Sa;"^2,%Power bw %,^";
240     OUTPUT @Sa;"^14,% Exit%,^";
250     !
260     OUTPUT @Sa;"IF K_ey,EQ,1;THEN;LIMIT_LINE,^";
270     OUTPUT @Sa;"ELIF K_ey,EQ,2;THEN;PWR_BW,^";
280     OUTPUT @Sa;"ELIF K_ey,EQ,14;THEN;ABORT,^";
290     OUTPUT @Sa;"ENDIF,^";
300     OUTPUT @Sa;"UNTIL K_ey,EQ,14,^";
310     OUTPUT @Sa;"IP,TS,^";
320     OUTPUT @Sa;"ADORT,^";
330     OUTPUT @Sa;"^^"
340     !
350 Define_keydef: !
360     OUTPUT @Sa;"KEYDEF 7,D_LP, %DLP TEST%,^";
370     !
380     OUTPUT @Sa;"FUNCDEF D,^";
390     OUTPUT @Sa;"KEYPST,^";
400     OUTPUT @Sa;"^^"
410     !
420     SUBEND
430     !
440     SUB Limit_line(@Sa)
450 Limit_line: !
460     OUTPUT @Sa;"CLR DSP,^";
470     OUTPUT @Sa;"FUNCDEF LIMIT_LINE,^";
480     OUTPUT @Sa;"PU;PA 0,654,^";
490     OUTPUT @Sa;"LINET 1,^";
500     OUTPUT @Sa;"PD;PA 100,654,^";
510     OUTPUT @Sa;"PU;PA 201,654,^";
520     OUTPUT @Sa;"PD;PA 300,654,^";
530     OUTPUT @Sa;"PU;PA 105,630,^";
540     OUTPUT @Sa;"TEXT @-35dB@,^";
550     OUTPUT @Sa;"PU;PA 205,720,^";
560     OUTPUT @Sa;"TEXT @-25dB@,^";
570     OUTPUT @Sa;"PU;PA 301,743,^";
580     OUTPUT @Sa;"LINET 1,^";
590     OUTPUT @Sa;"PD;PA 400,743,^";
600     OUTPUT @Sa;"PU;PA 601,743,^";
610     OUTPUT @Sa;"LINET 1,^";
620     OUTPUT @Sa;"PD;PA 700,743,^";
630     OUTPUT @Sa;"PU;PA 701,654,^";
640     OUTPUT @Sa;"LINET 1,^";
650     OUTPUT @Sa;"PD;PA 1000,654;HD,^";
660     OUTPUT @Sa;"^^"
670     SUBEND
680     SUB Pwr_bw(@Sa)
690 Pwr_bw: !
700     ! Calculating Power band width
710     OUTPUT @Sa;"VARDEF P_bw,0,^";
720     OUTPUT @Sa;"FUNCDEF PWR_BW,^^";
730     OUTPUT @Sa;"CLRW TRA,^";
740     OUTPUT @Sa;"CLR DSP,^";
750     OUTPUT @Sa;"SNGLS,^";
760     OUTPUT @Sa;"MXMH TRA;TS;TS;TS,^";
770     OUTPUT @Sa;"MOV P_bw,PWRBW TRA,99.0,^";
780     OUTPUT @Sa;"DIV P_bw,P_bw,1000000,^";
790     OUTPUT @Sa;"PU;PA 10,800;HD,^";
800     OUTPUT @Sa;"TEXT @POWER_BW = @,^";
810     OUTPUT @Sa;"DSPLY P_bw,8,3,^";
820     OUTPUT @Sa;"TEXT @ MHz @,^";
830     OUTPUT @Sa;"^^"
840     SUBEND
```

Fig. 4.1

Program for Calculation of Occupied Bandwidth

4.2 Test Result

The test result is shown below.

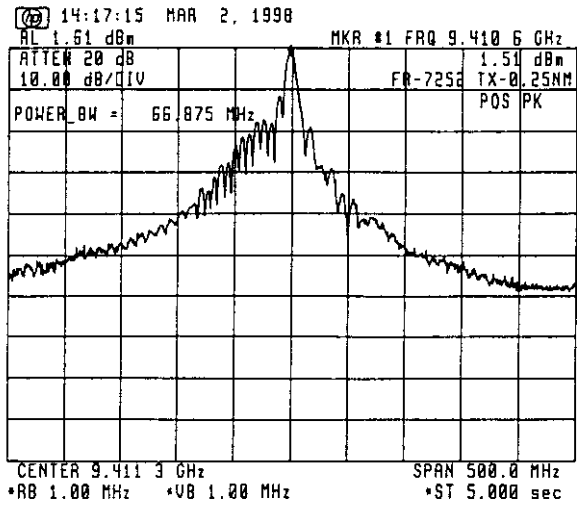

Fig. 4.2 Measurement of Occupied Bandwidth

Occupied bandwidth = 66.875 MHz

5 EMISSION LIMITATIONS (FCC ,80.211)

Data for an authorized bandwidth of 100 MHz

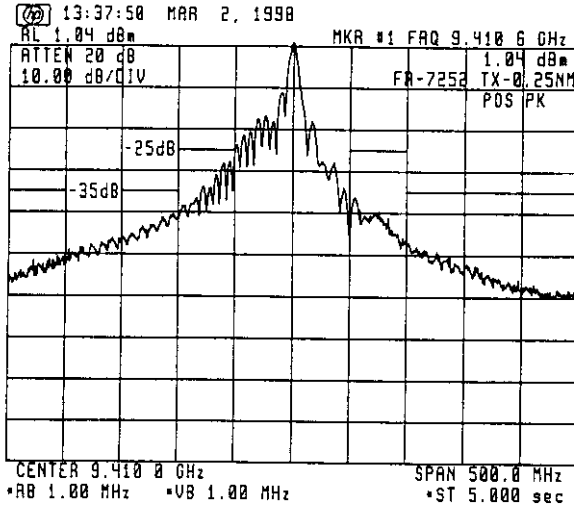

Fig. 5.1

Short Pulse

Pm (mean power) = 4.154 W
 fo = 9410.6 MHz
 43 + 10 log Pm = 49.18 dB

Scale: 10 dB/div.
 50 MHz/div.

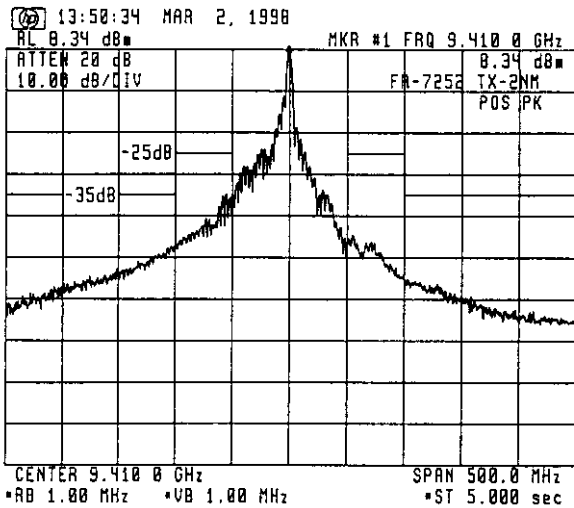

Fig. 5.2

Middle Pulse

Pm (mean power) = 6.114 W
 fo = 9410.0 MHz
 43 + 10 log Pm = 50.86 dB

Scale: 10 dB/div.
 50 MHz/div.

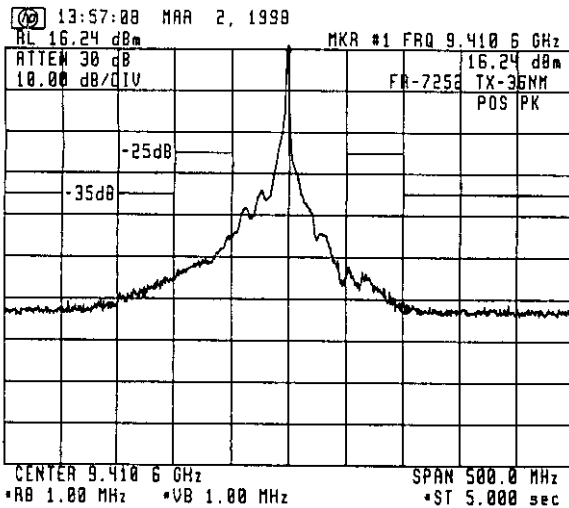

Fig. 5.3

Long 1 Pulse

Pm (mean power) = 9.79 W
 fo = 9410.6 MHz
 43 + 10 log Pm = 52.91 dB

Scale: 10 dB/div.
 50 MHz/div.

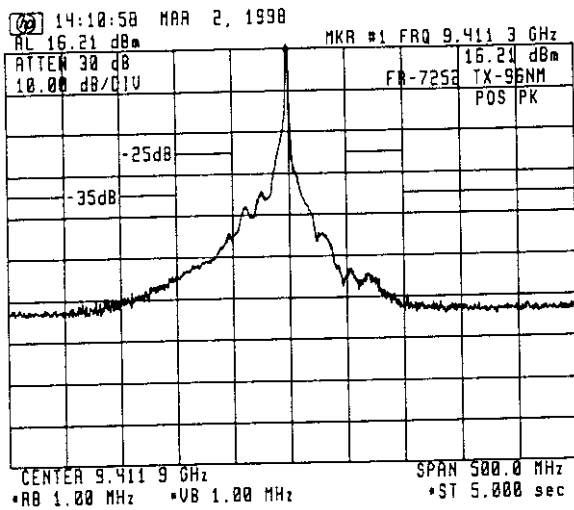

Fig. 5.4

Long 2 Pulse

Pm (mean power) = 8.704 W
 fo = 9411.3MHz
 43 + 10 log Pm = 52.4 dB

Scale: 10 dB/div.
 50 MHz/div.

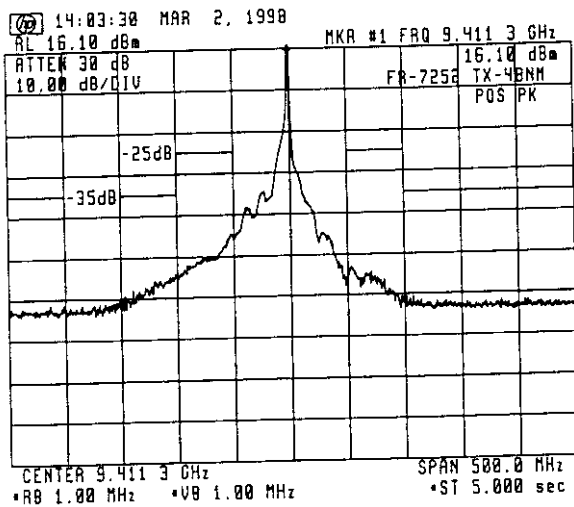

Fig. 5.5

Long 3 Pulse

Pm (mean power) = 8.028 W
 fo = 9411.3 MHz
 43 + 10 log Pm = 52.05 dB

Scale: 10 dB/div.
 50 MHz/div.

6 SPURIOUS EMISSIONS AT ANTENNA TERMINALS (FCC 2.991)

6.1 Test Instrument Setup

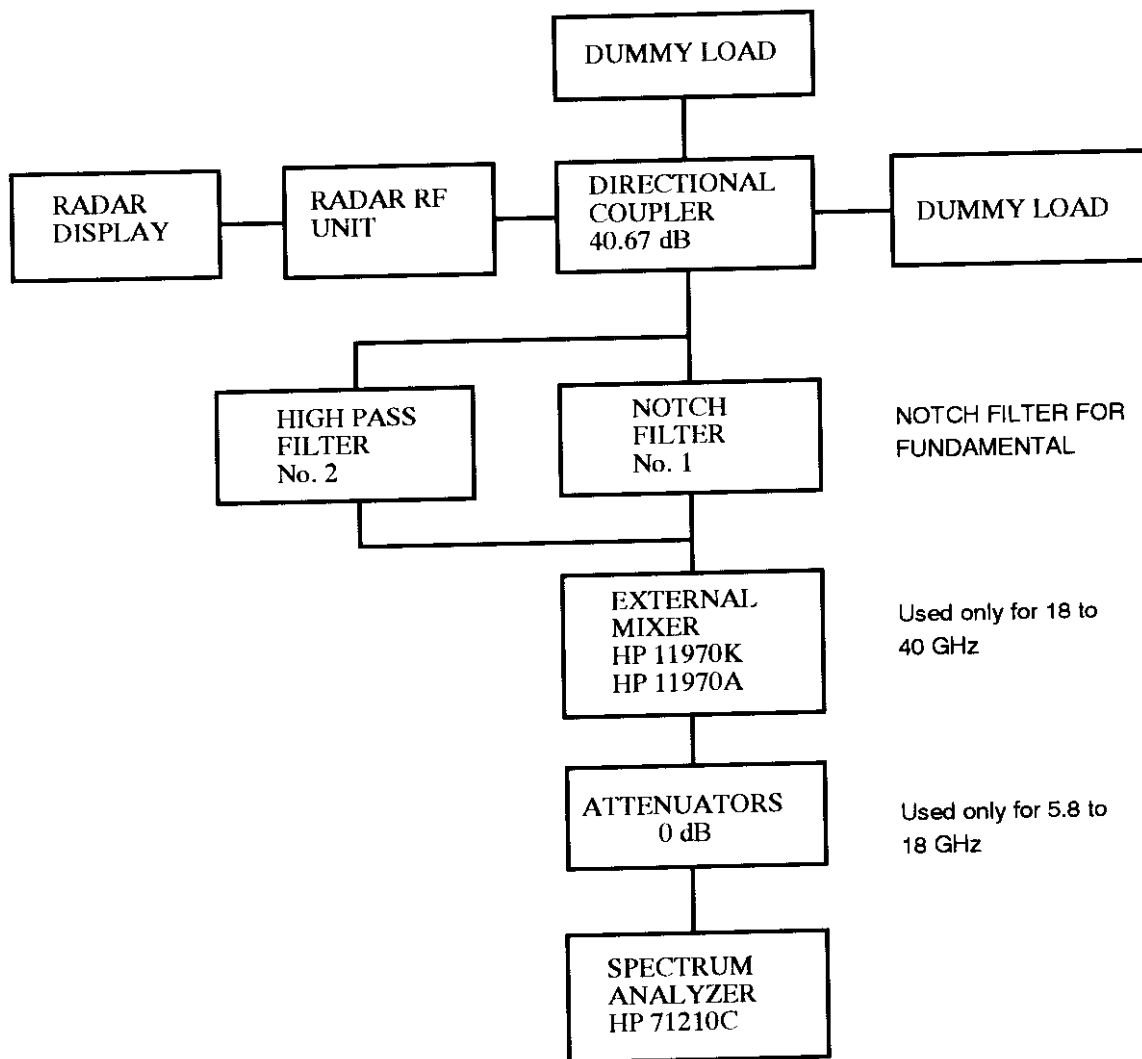

Fig. 6.1

Test Results:

As shown on the succeeding pages, the spurious emissions at the equipment output terminal are lower than the specified limits.

Characteristic of Filter No. 1 (for X-band)

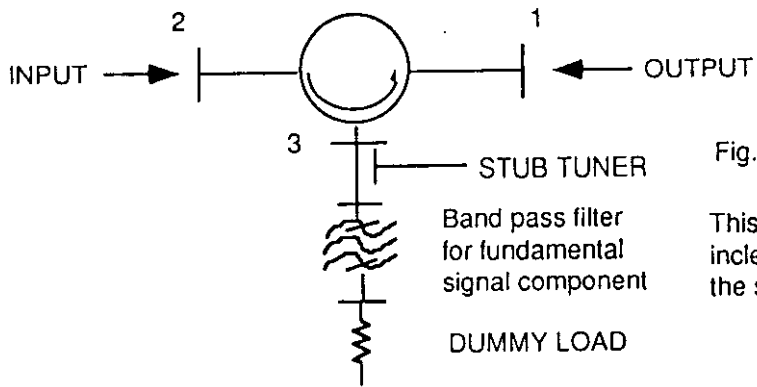

Fig. 6.2 Setup of Notch Filter No.1

This notch filter is used to increase the dynamic range of the spectrum analyzer

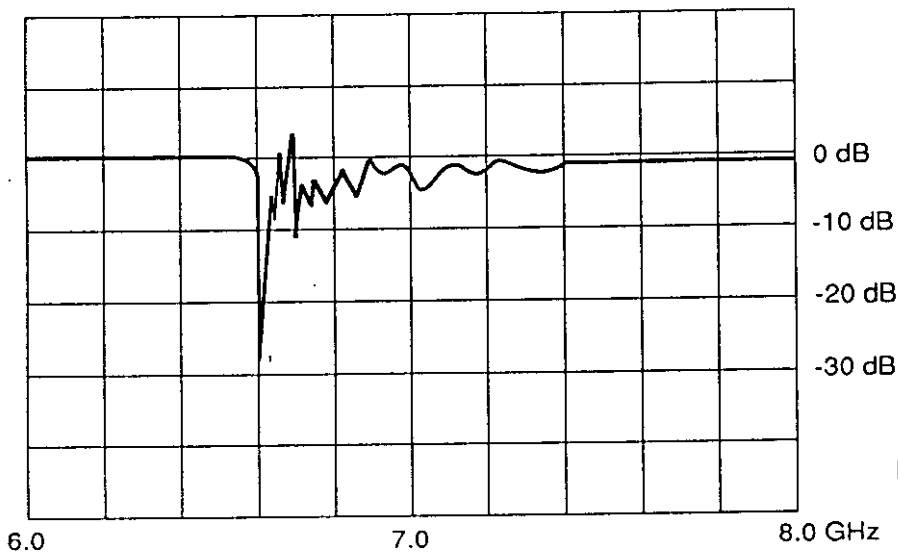

Fig. 6.3

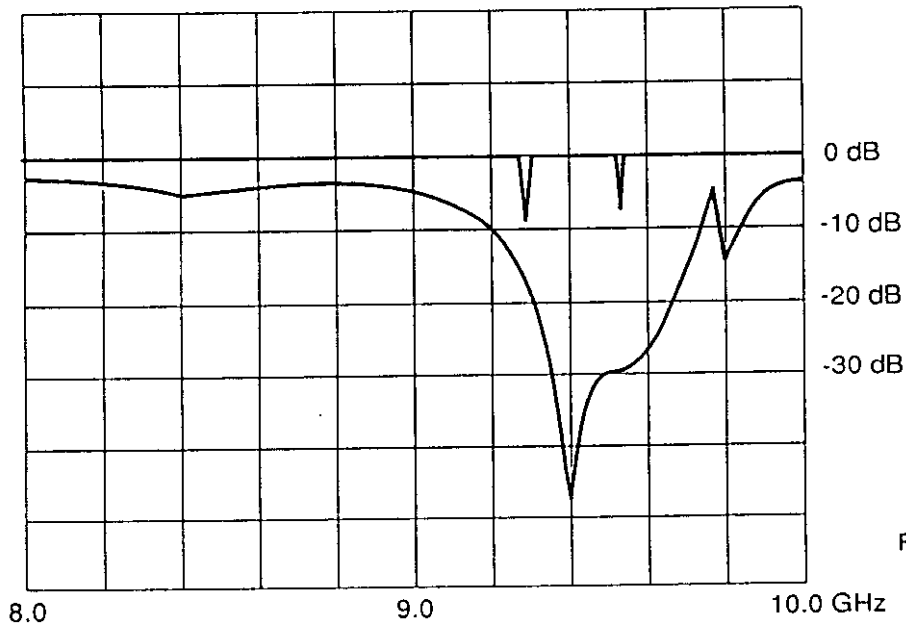

Fig. 6.4

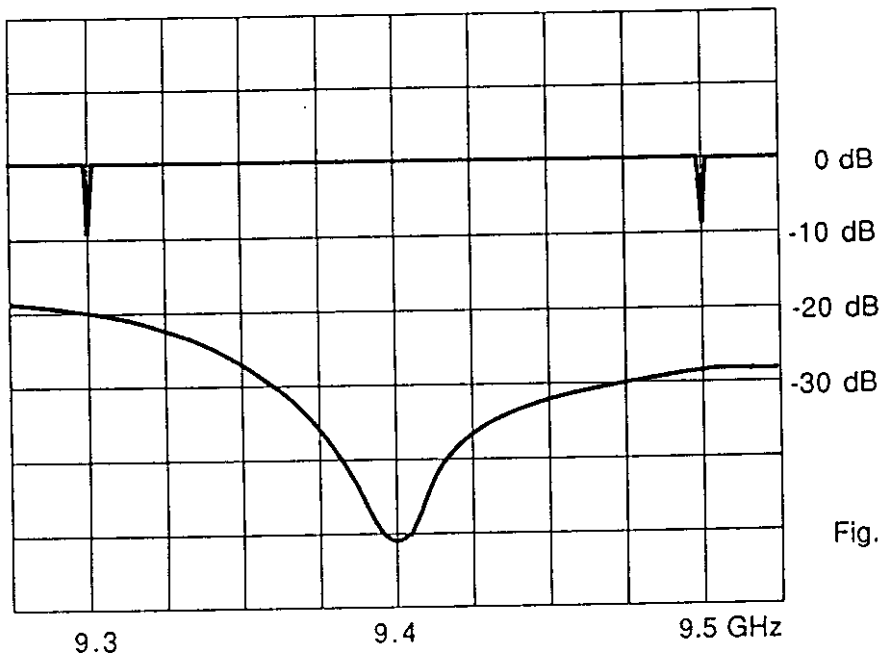
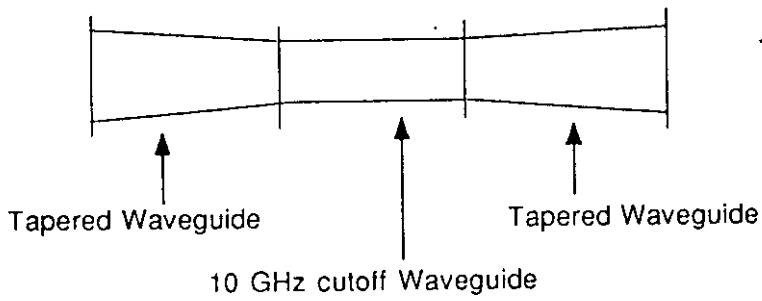

Fig. 6.5

Characteristic of Filter No. 2 (for X-band)



This filter is used to filter out the high level fundamental signal to avoid damage to the analyzer.

High Pass Filter Construction

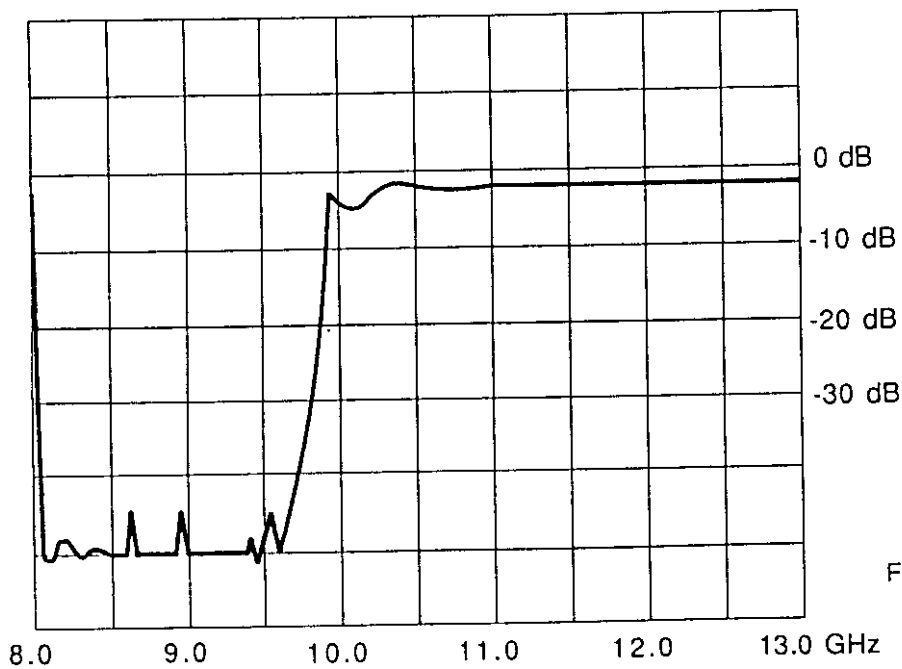
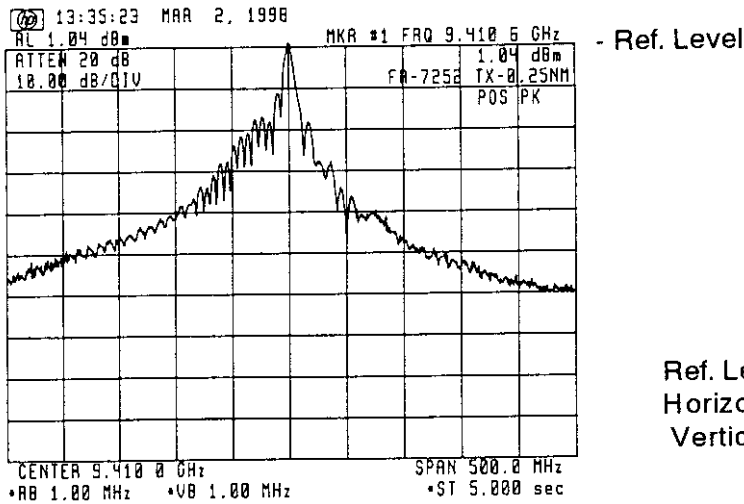

Fig.6.6

6.2 Spurious Emissions at Antenna Terminal (0.25 n.m. Range)

FCC LIMITATION : $43 + 10 \log P_m = 49.18 \text{ dB}$



Ref. Level: 1.04 dBm
 Horizontal: 50 MHz/div.
 Vertical: 10 dB/div.

Fig. 6.7 Without Filter

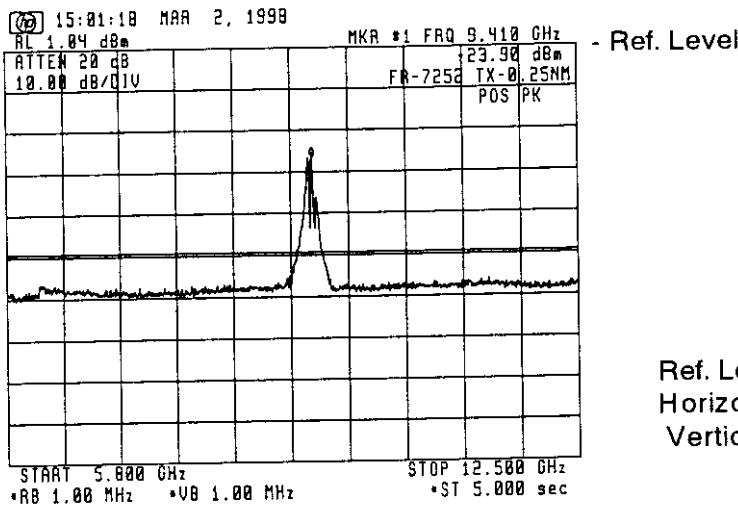

Ref. Level: 1.04 dBm
 Horizontal: 670 MHz/div.
 Vertical: 10 dB/div.

Fig. 6.8 With Filter No.1

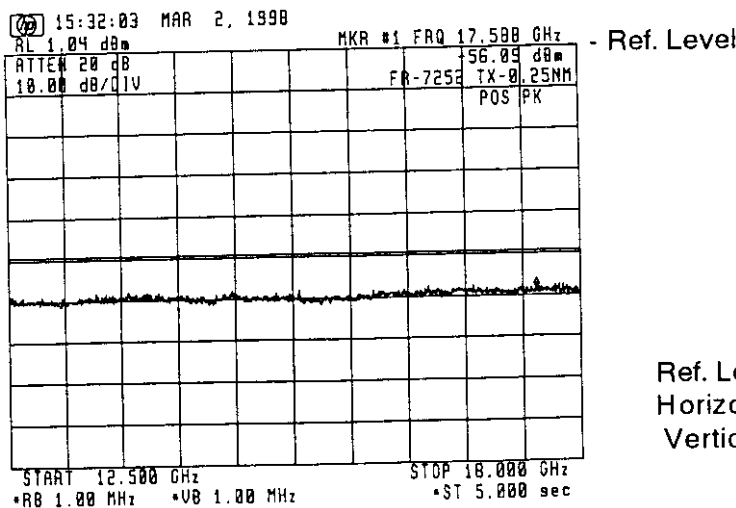

Ref. Level: 1.04 dBm
 Horizontal: 550 MHz/div.
 Vertical: 10 dB/div.

Fig. 6.9 With Filter No. 2

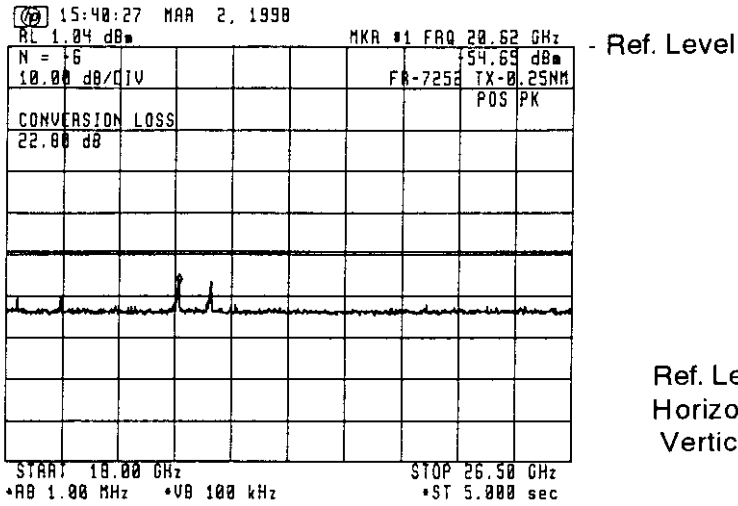

Ref. Level: 1.04 dBm
 Horizontal: 850 MHz/div.
 Vertical: 10 dB/div.

Fig. 6.10 With Filter No. 2

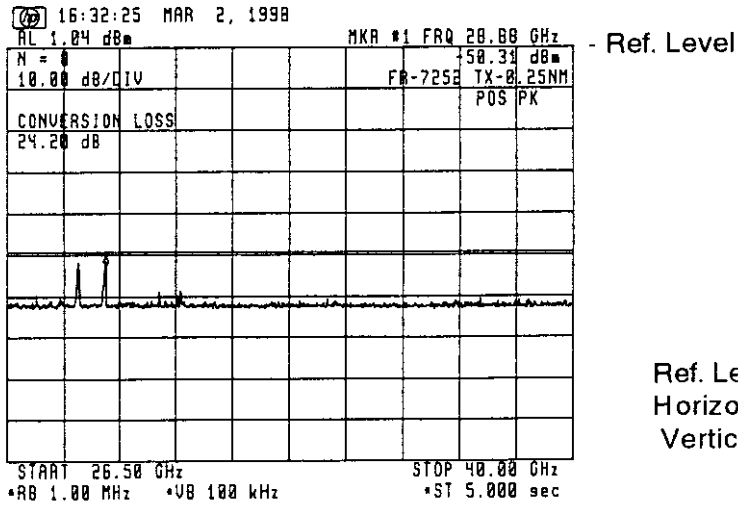

Ref. Level: 1.04 dBm
 Horizontal: 1.35 GHz/div.
 Vertical: 10 dB/div.

Fig. 6.11 With Filter No. 2

6.3 Spurious Emissions at Antenna Terminal (2 n.m. Range)

FCC LIMITATION : $43 + 10 \log P_m = 50.86 \text{ dB}$

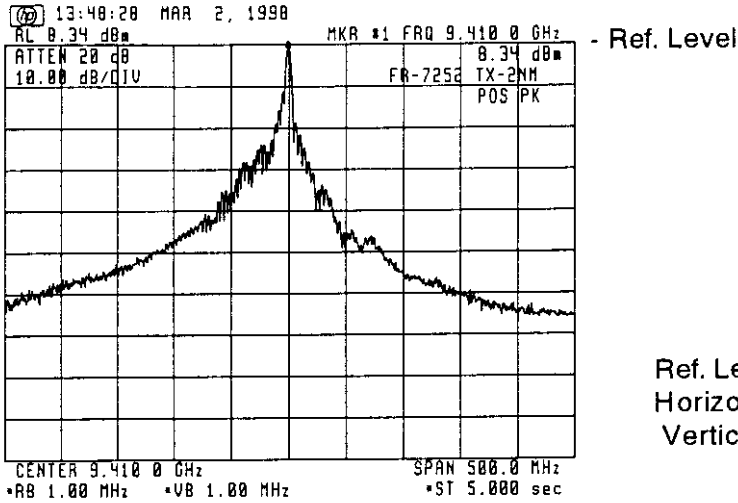

Ref. Level: 8.34 dBm
 Horizontal: 50 MHz/div.
 Vertical: 10 dB/div.

Fig. 6.12 Without Filter

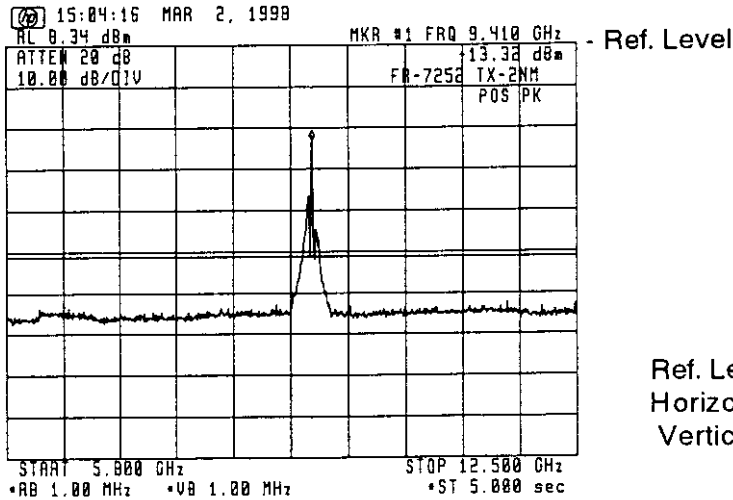

Ref. Level: 8.34 dBm
 Horizontal: 670 MHz/div.
 Vertical: 10 dB/div.

Fig. 6.13 With Filter No.1

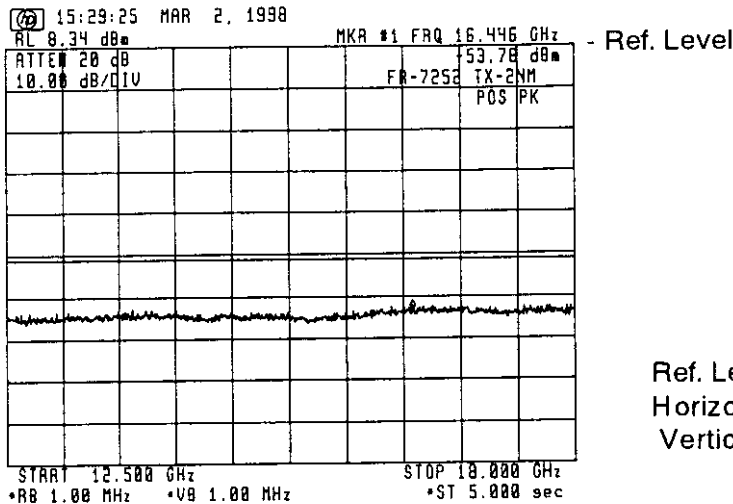

Ref. Level: 8.34 dBm
 Horizontal: 550 MHz/div.
 Vertical: 10 dB/div.

Fig. 6.14 With Filter No. 2

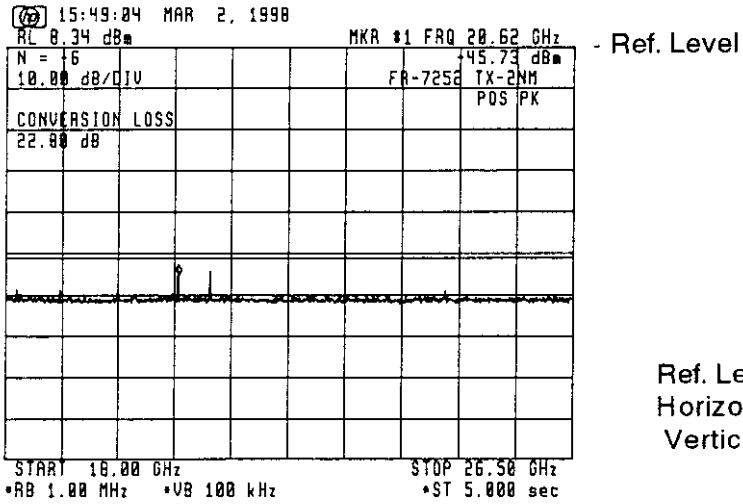

Fig. 6.15 With Filter No. 2

Ref. Level: 8.34 dBm
 Horizontal: 850 MHz/div.
 Vertical: 10 dB/div.

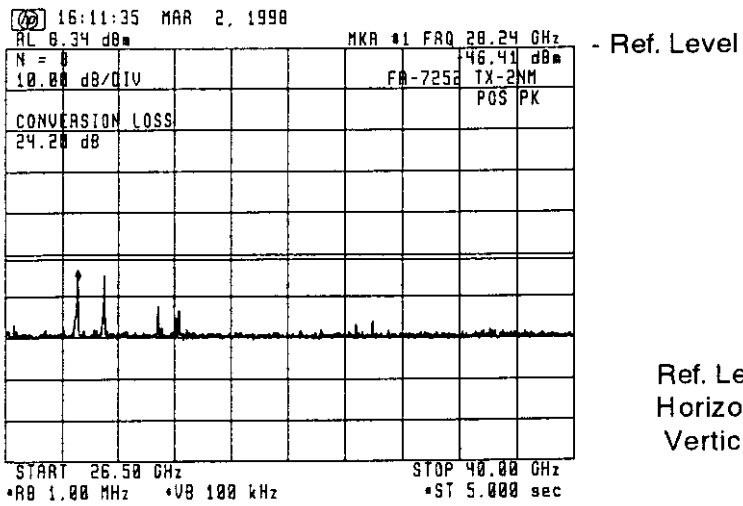
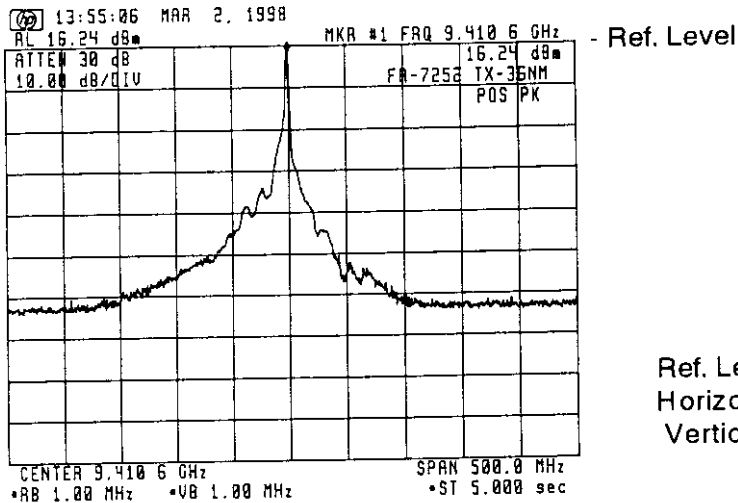

Fig. 6.16 With Filter No. 2

Ref. Level: 8.34 dBm
 Horizontal: 1.35 GHz/div.
 Vertical: 10 dB/div.

6.4 Spurious Emissions at Antenna Terminal (36 n.m. Range)

FCC LIMITATION : $43 + 10 \log P_m = 52.91 \text{ dB}$



Ref. Level: 16.24 dBm
 Horizontal: 50 MHz/div.
 Vertical: 10 dB/div.

Fig. 6.17 Without Filter

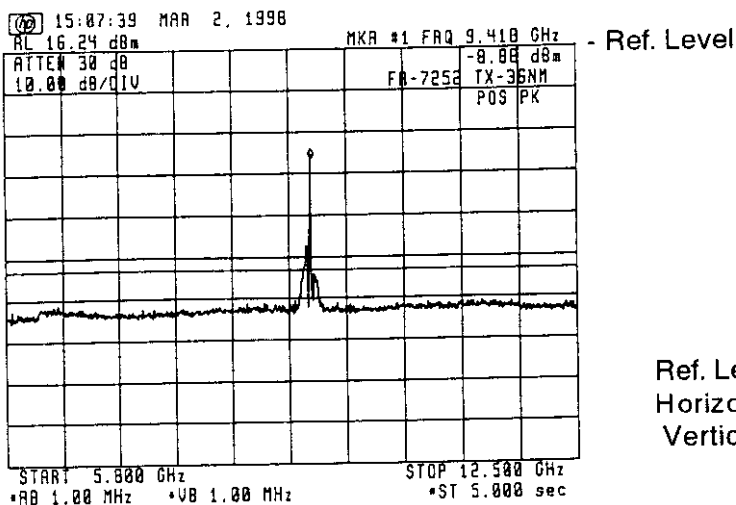

Ref. Level: 16.24 dBm
 Horizontal: 670 MHz/div.
 Vertical: 10 dB/div.

Fig. 6.18 With Filter No.1

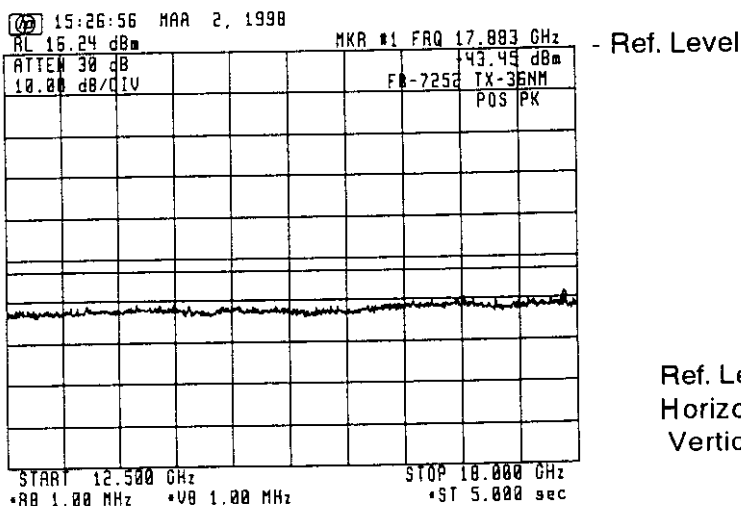

Ref. Level: 16.24 dBm
 Horizontal: 550 MHz/div.
 Vertical: 10 dB/div.

Fig. 6.19 With Filter No. 2

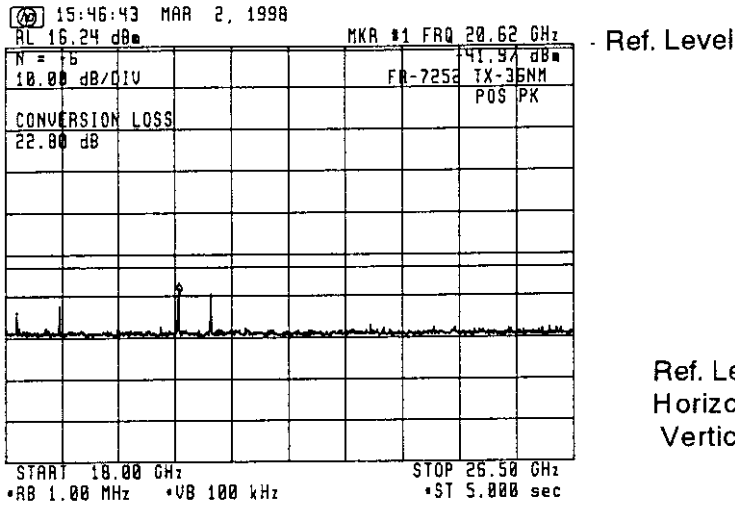

Ref. Level: 16.24 dBm
 Horizontal: 850 MHz/div.
 Vertical: 10 dB/div.

Fig. 6.20 With Filter No. 2

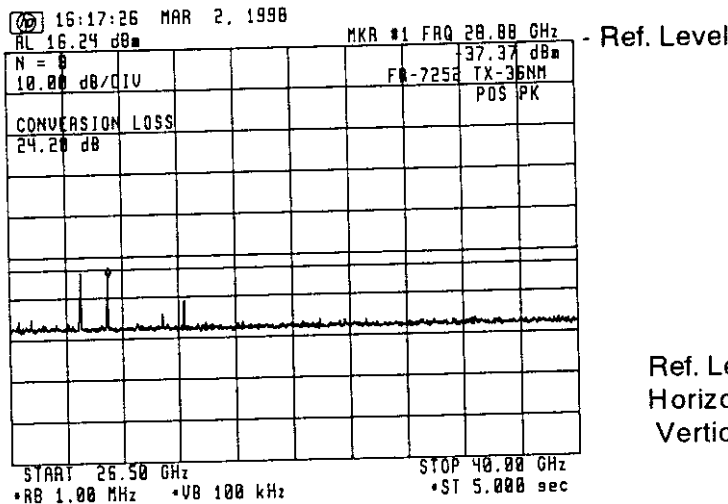

Ref. Level: 16.24 dBm
 Horizontal: 1.35 GHz/div.
 Vertical: 10 dB/div.

Fig. 6.21 With Filter No. 2

6.5 Spurious Emissions at Antenna Terminal (48 n.m. Range)

FCC LIMITATION : $43 + 10 \log P_m = 52.4 \text{ dB}$

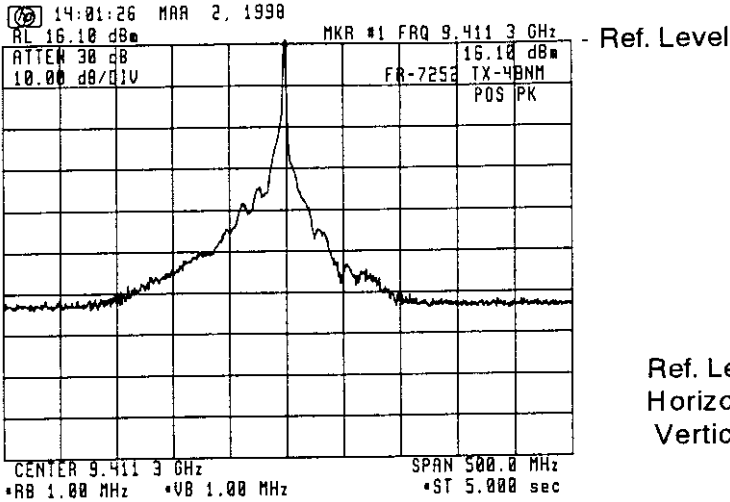

Ref. Level: 16.1 dBm
 Horizontal: 50 MHz/div.
 Vertical: 10 dB/div.

Fig. 6.22 Without Filter

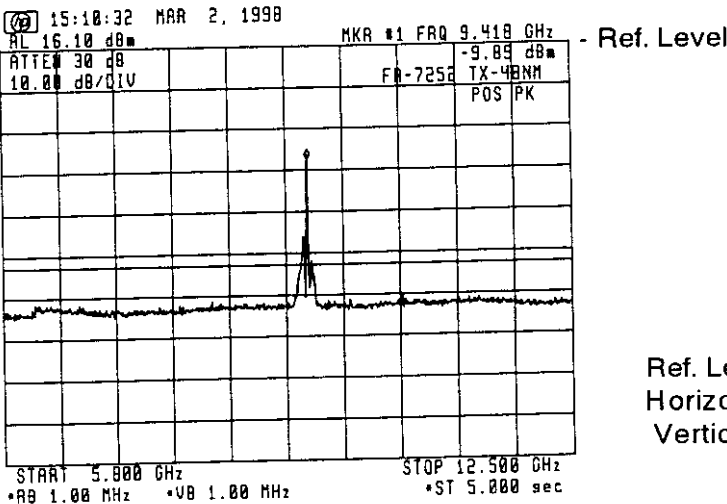

Ref. Level: 16.1 dBm
 Horizontal: 670 MHz/div.
 Vertical: 10 dB/div.

Fig. 6.23 With Filter No.1

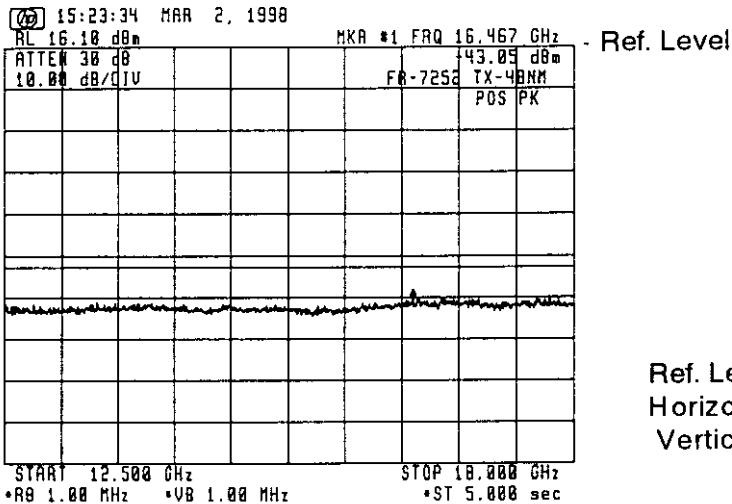

Ref. Level: 16.1 dBm
 Horizontal: 550 MHz/div.
 Vertical: 10 dB/div.

Fig. 6.24 With Filter No. 2

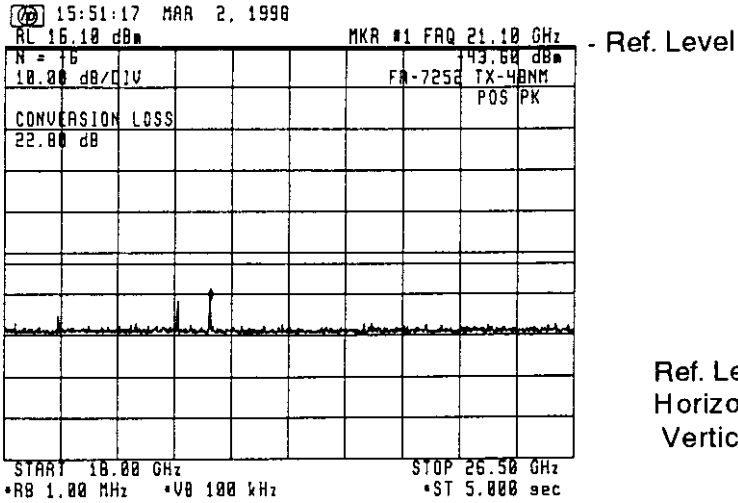

Ref. Level: 16.1 dBm
 Horizontal: 850 MHz/div.
 Vertical: 10 dB/div.

Fig. 6.25 With Filter No. 2

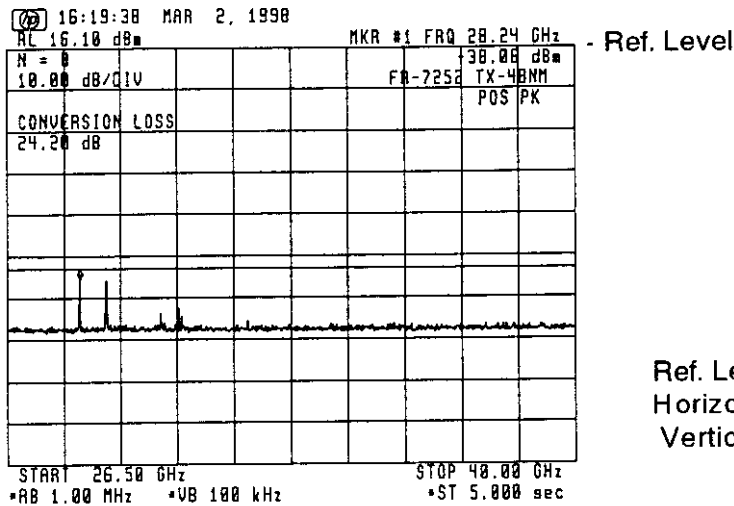

Ref. Level: 16.1 dBm
 Horizontal: 1.35 GHz/div.
 Vertical: 10 dB/div.

Fig. 6.26 With Filter No. 2

6.6 Spurious Emissions at Antenna Terminal (96 n.m. Range)

FCC LIMITATION : $43 + 10 \log P_m = 52.05 \text{ dB}$

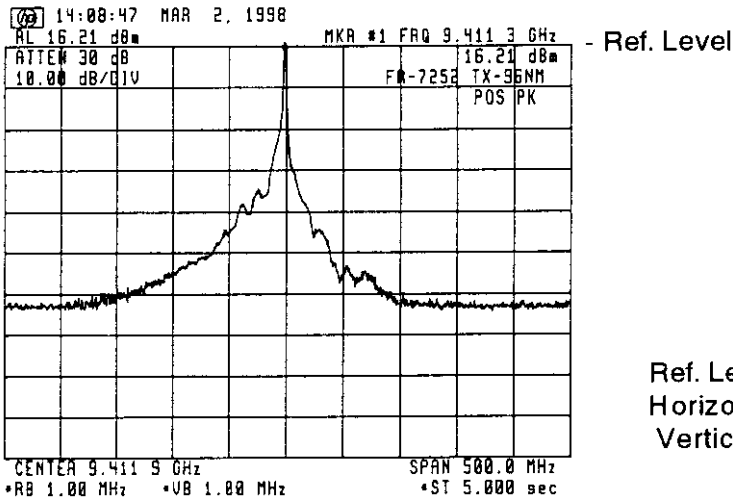

Ref. Level: 16.21 dBm
 Horizontal: 50 MHz/div.
 Vertical: 10 dB/div.

Fig. 6.27 Without Filter

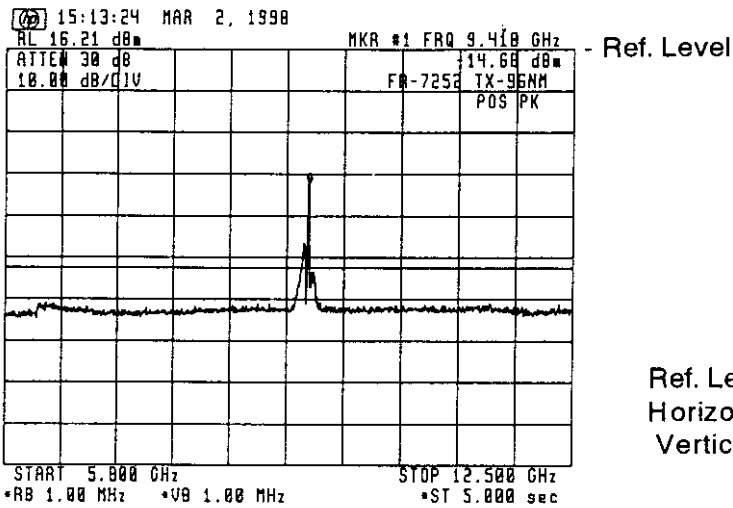

Ref. Level: 16.21 dBm
 Horizontal: 670 MHz/div.
 Vertical: 10 dB/div.

Fig. 6.28 With Filter No.1

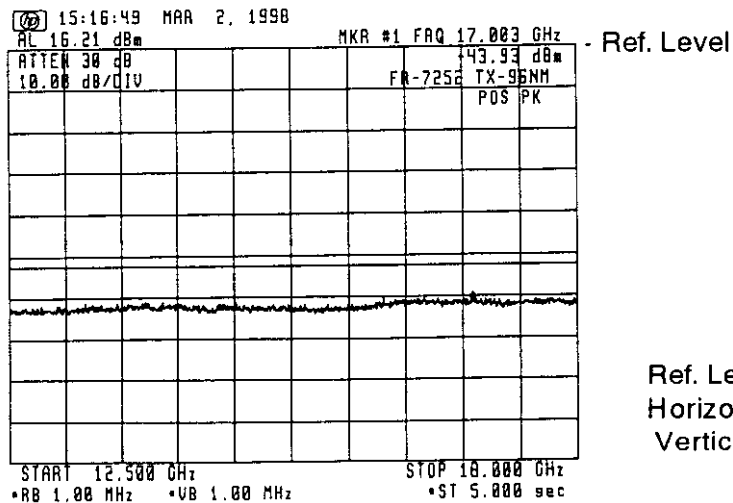

Ref. Level: 16.21 dBm
 Horizontal: 550 MHz/div.
 Vertical: 10 dB/div.

Fig. 6.29 With Filter No. 2

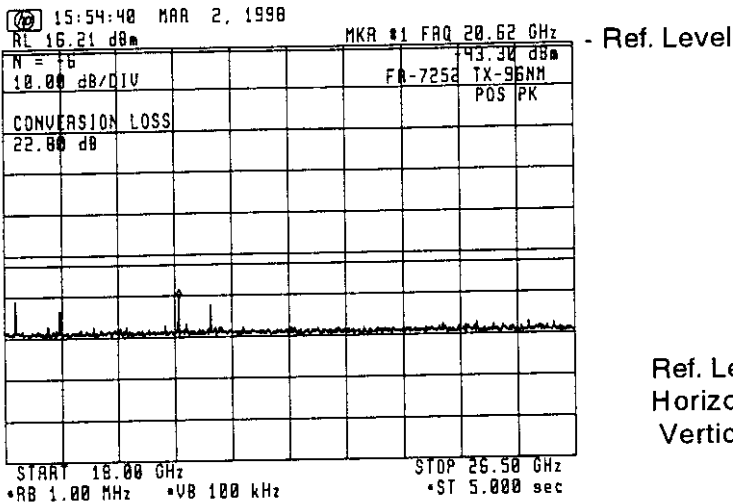

Ref. Level: 16.21 dBm
 Horizontal: 850 MHz/div.
 Vertical: 10 dB/div.

Fig. 6.30 With Filter No. 2

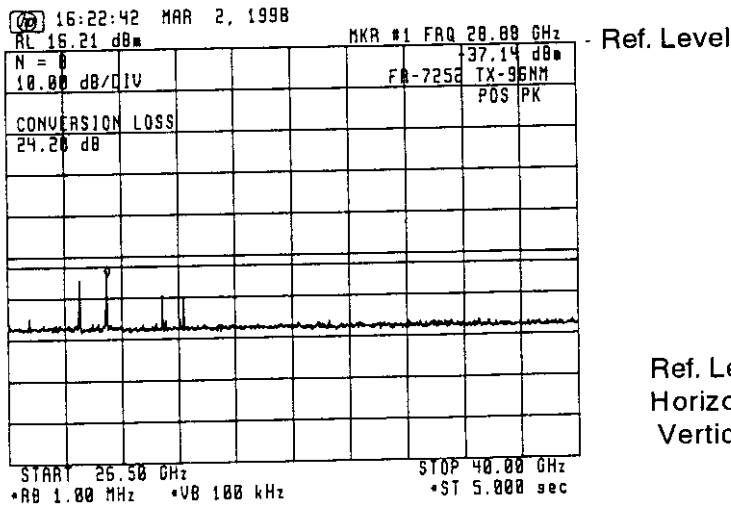

Ref. Level: 16.21 dBm
 Horizontal: 1.35 GHz/div.
 Vertical: 10 dB/div.

Fig. 6.31 With Filter No. 2

7 FIELD STRENGTH OF SPURIOUS RADIATION (FCC 2.993)

7.1 Test Site: Rooftop of 6-story building, FURUNO
ELECTRIC CO., LTD. in Nishinomiya City, Japan

7.2 Date: January 1998

7.3 Distance between the radar set and
measuring antenna: 10 m

7.4 Radar setting:

	<u>Range</u>	<u>Pulse length</u>
Short Pulse :	0.25 n.m.	0.08 μ s
Middle Pulse :	2 n.m.	0.3 μ s
Long 1 Pulse :	36 n.m.	0.8 μ s
Long 2 Pulse :	48 n.m.	0.8 μ s
Long 3 Pulse :	96 n.m.	0.8 μ s

7.5 Measuring Instruments

<u>Instrument</u>	<u>Type</u>	<u>Mfr.</u>	<u>Calibration</u>
Spectrum Analyzer	71210C	HP	Aug. 1997
Biconical Antenna	BIA-25	Electro Metrics	Nov. 1995
Conical Log-Spiral Antenna	LCA-25	Electro Metrics	Nov. 1995
Double Ridged Guide Horn Antenna	RGA-180	Electro Metrics	Nov. 1995
Broadband Rod Antenna	95010-1	Advanced Electronics	Sep. 1996
Horn Antenna		Toshiba	
External Mixer	11970K	HP	Aug. 1997
External Mixer	11970A	HP	Aug. 1997

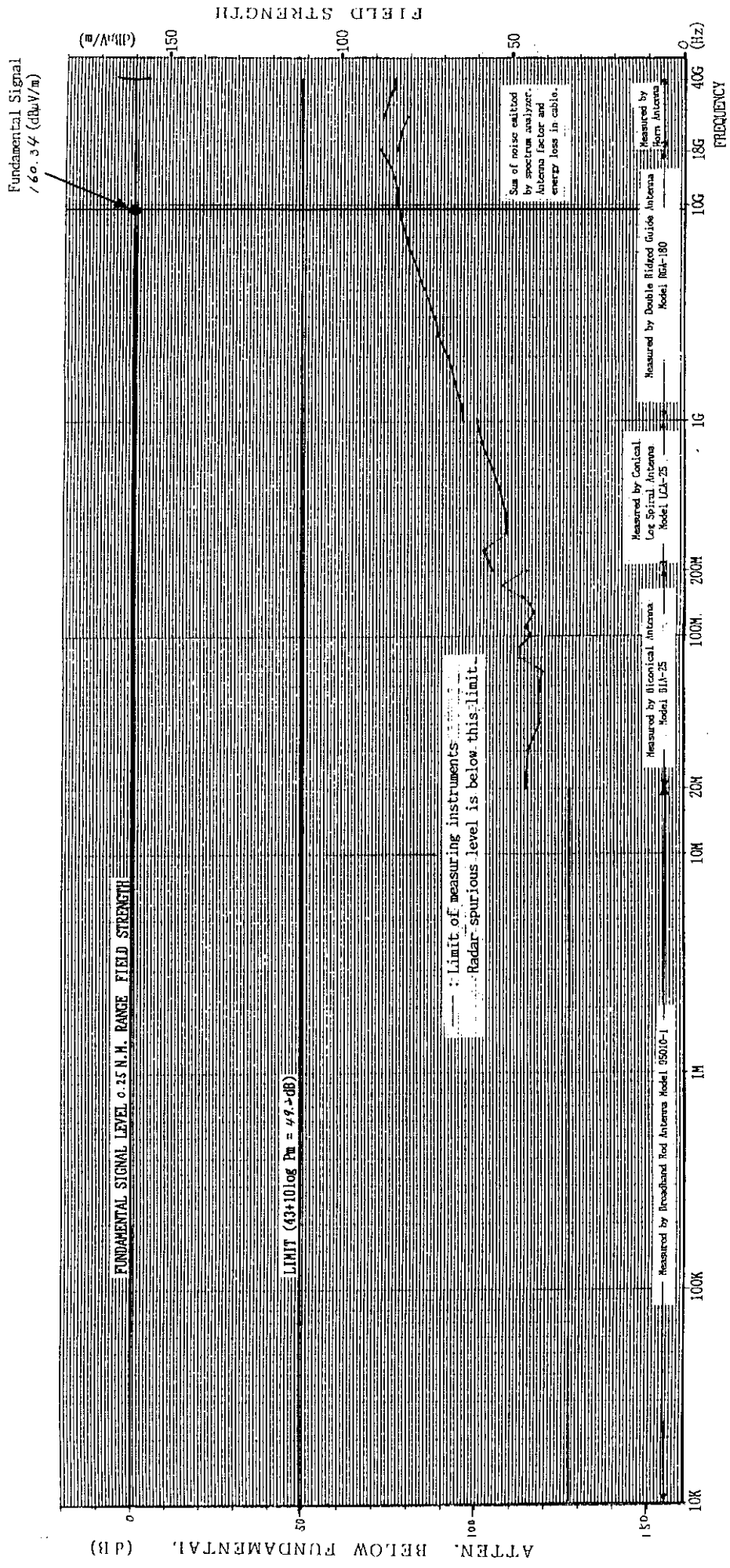

Graph 7 - | Field strength of spurious radiation measured with pick-up antenna (short ranges)

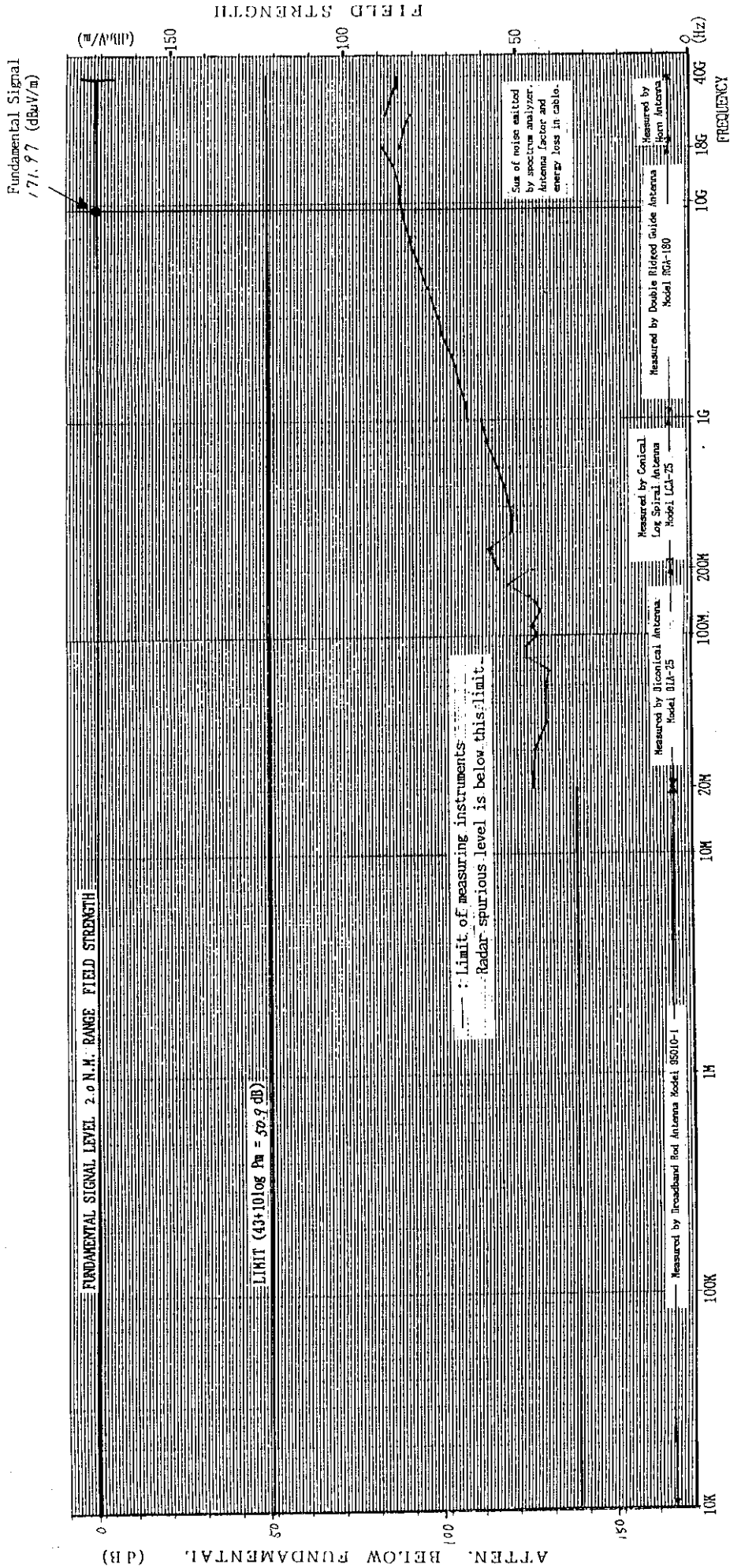

Graph 7-2 Field strength of spurious radiation measured with pick-up antenna (Middle ranges)

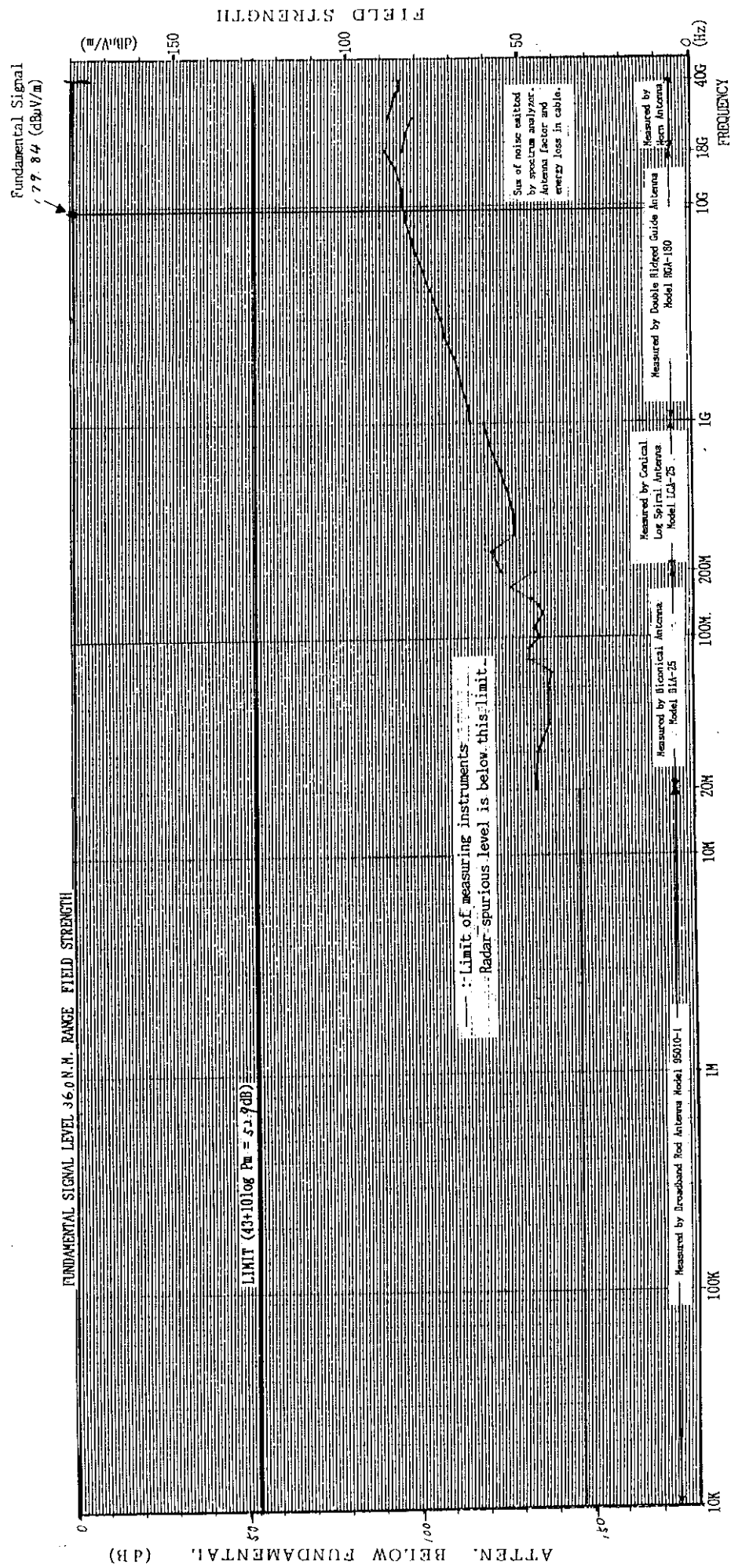

Graph 7 - 3 Field strength of spurious radiation measured with pick-up antenna (long ranges)

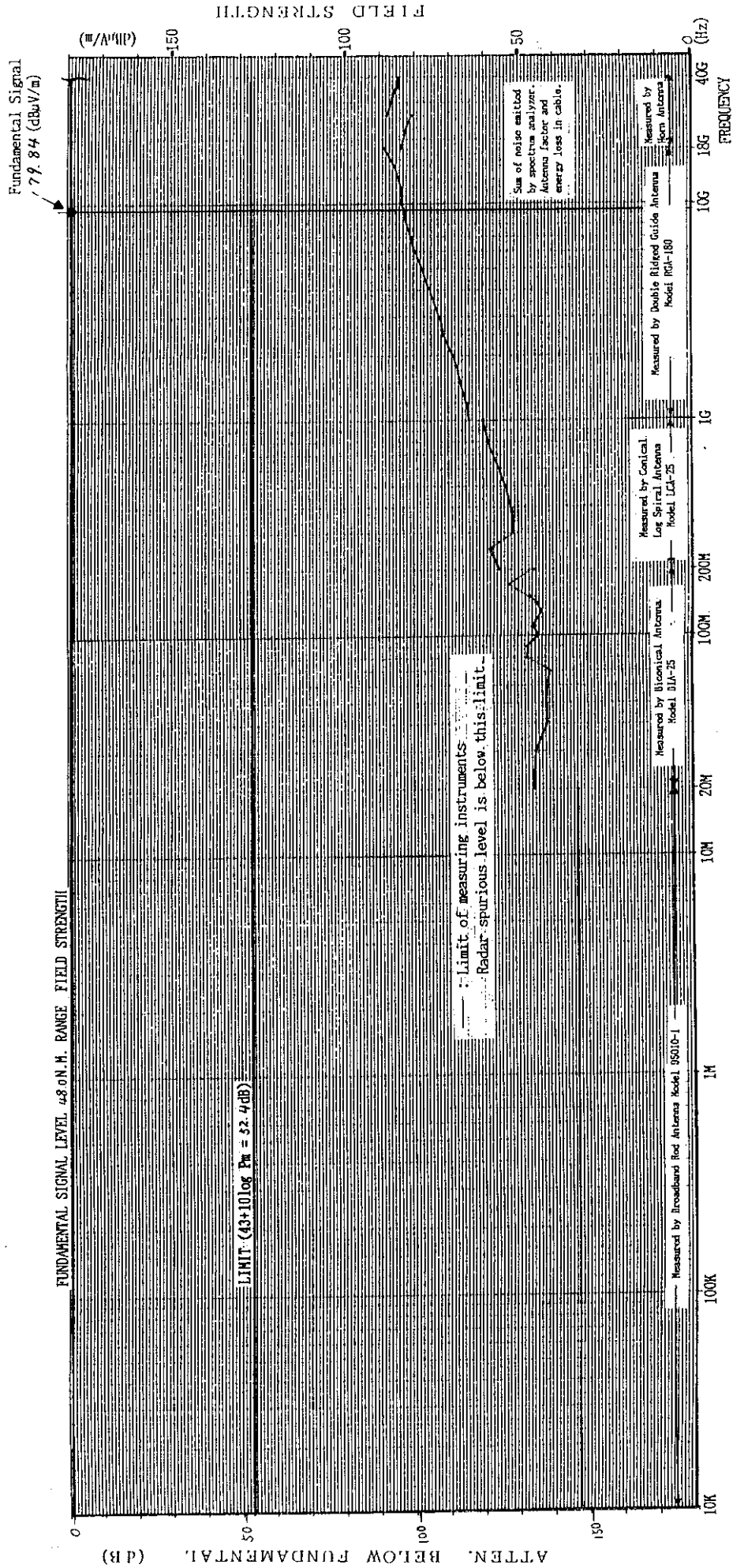

Graph 7 - 44 Field strength of spurious radiation measured with pick-up antenna (long 2 ranges)

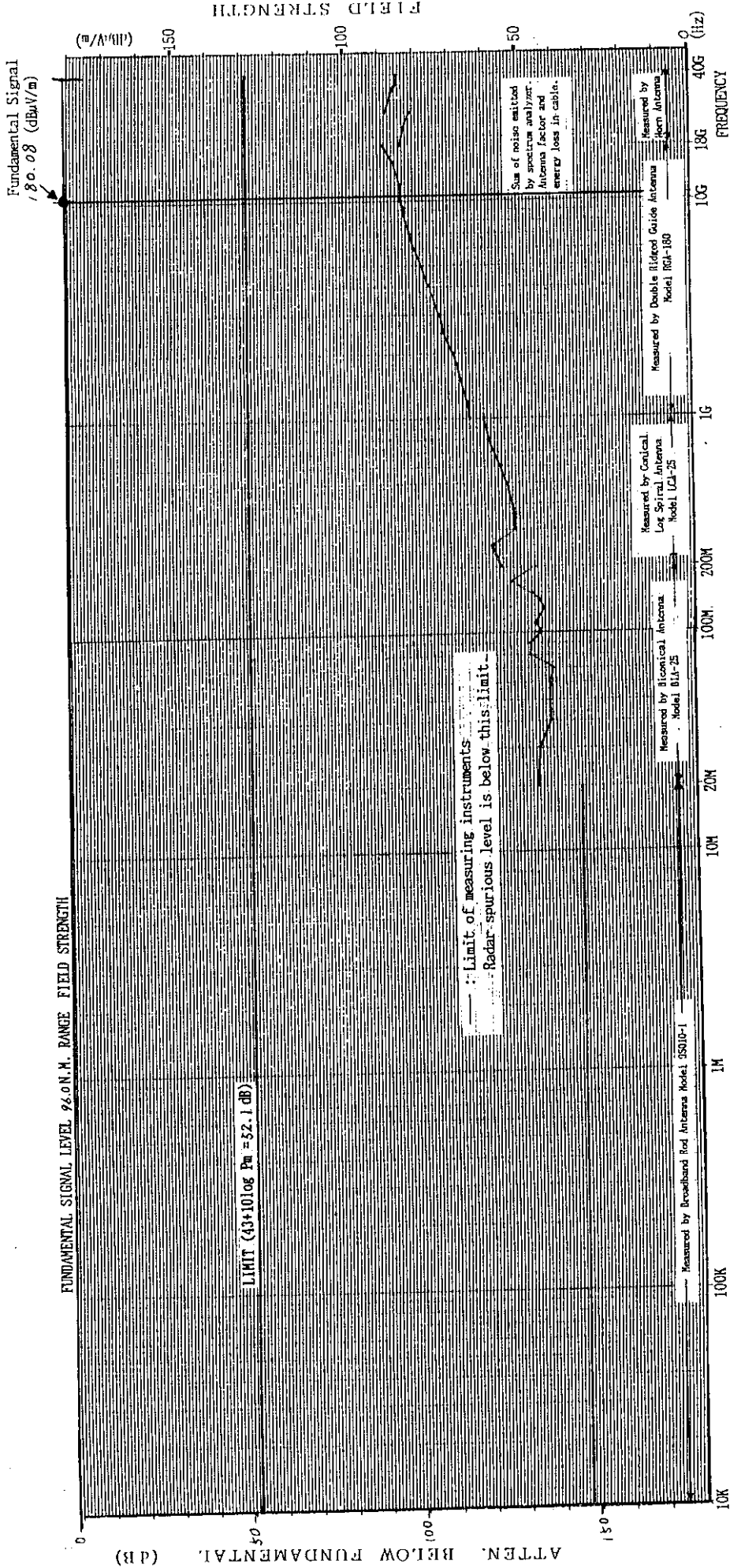

Graph 7-5 Field strength of spurious radiation measured with pick-up antenna (long 3 ranges)

8 **FREQUENCY STABILITY WITH VARIATION OF AMBIENT TEMPERATURE AND POWER SUPPLY (FCC 2.995)**

8.1 Setup for Measurement

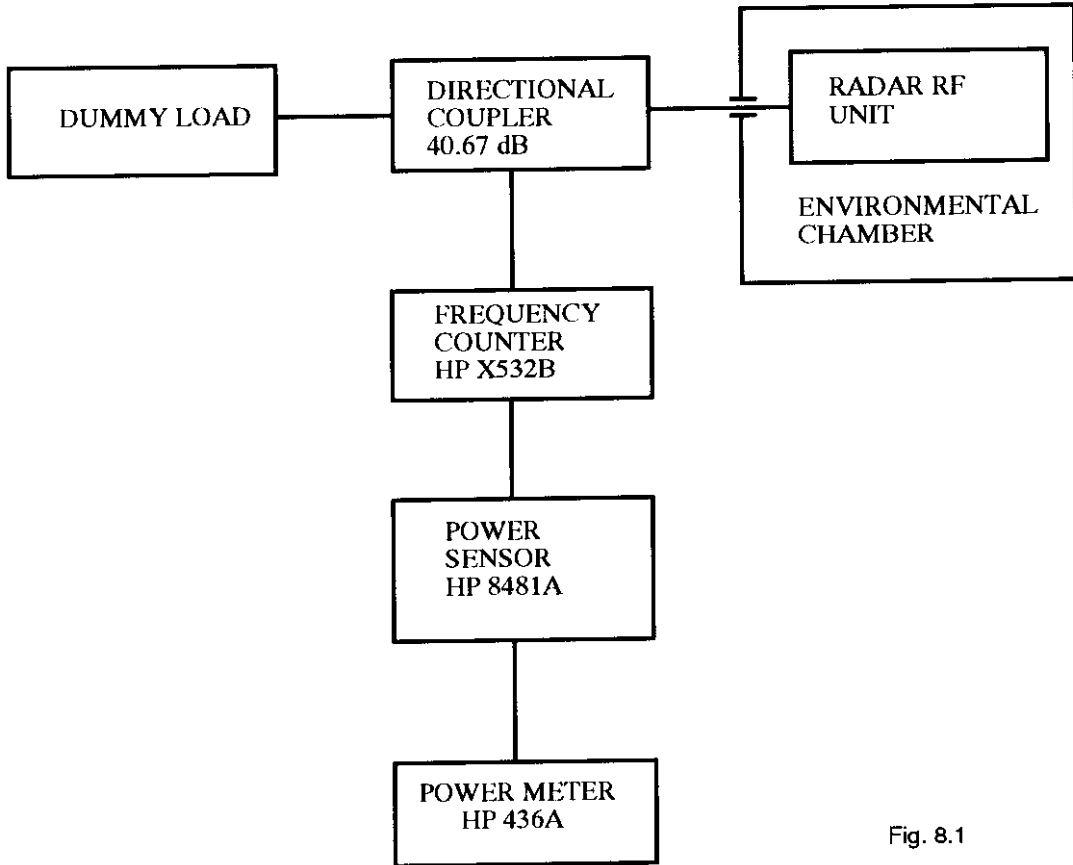

Fig. 8.1

8.2 Test Result

Shown on the next page.

FREQUENCY STABILITY WITH VOLTAGE VARIATION

The built-in voltage regulator allows no frequency variation against variations of $\pm 15\%$ of power supply voltage.

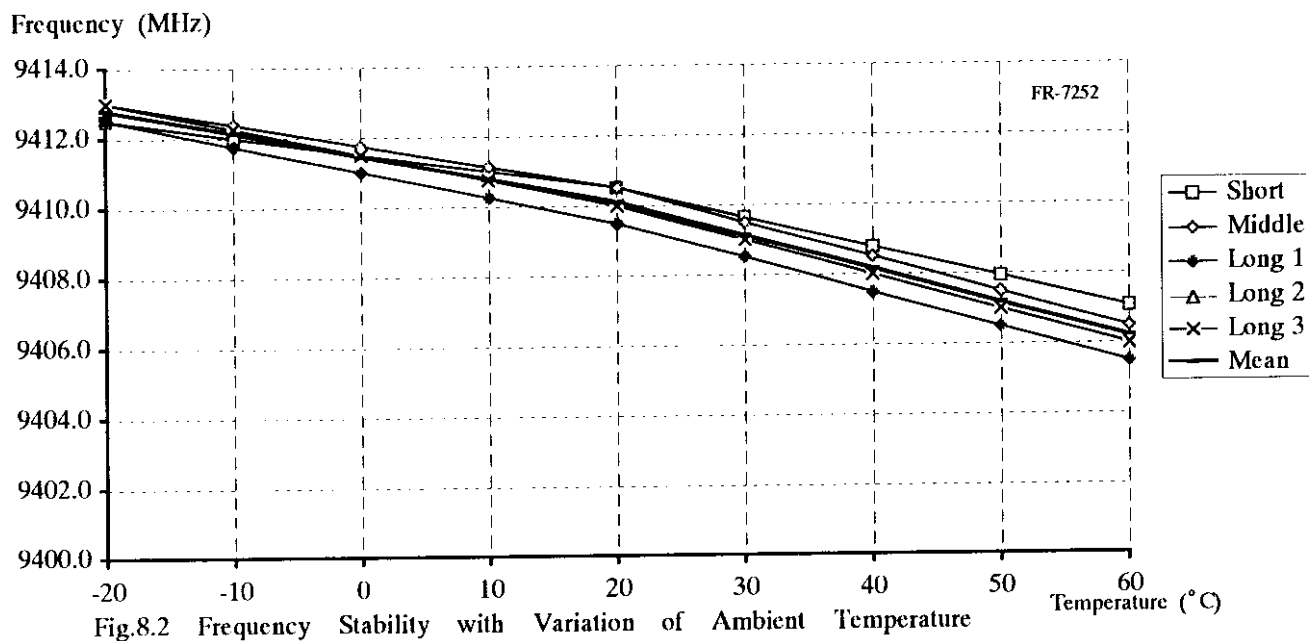

Fig 8.2 Frequency Stability with Variation of Ambient Temperature

11 SUPPRESSION OF INTERFERENCE ABOARD SHIP (FCC 80.217)

11.1 Measuring Antenna Characteristics at Representative Frequencies

Whip antennas are used to determine the level of interference caused by the radar to shipboard receivers. These antennas have the following characteristics (refer to impedance charts attached):

Length	Tested Frequency	Impedance	θ	R	C or L
6m	500.5 kHz	1 k Ω	-90°	0 Ω	80 pF
6m	1.992 MHz	1.25 k Ω	-86°	87.2 Ω	64 pF
6m	10.00204 MHz	158 Ω		109 Ω	140 pF
4m	27.5 MHz	95 Ω		83.5 Ω	128 pF
5/8 λ	150 MHz	116.5 Ω		105.5 Ω	52.5 nH
1/4 λ	450 MHz	70.5 Ω		34.5 Ω	5.68 pF

11.2 Test Site: Rooftop of 6-story building (See photos.)

11.3 Measuring Instruments

- 1) HP4815A RF vector impedance meter
- 2) Spectrum analyzer, ADVANTEST TR4172
- 3) Spectrum analyzer, HP8566B
- 4) Antennas
 - 14 kHz - 10 MHz: 6m whip
 - 10 - 30 MHz: 4m whip
 - 30 - 300 MHz: VHF whip
 - 300 - 1000 MHz: UHF whip

11.4 Test Results

Interference levels to the respective antennas were measured at 2m from the radar which was put in OFF, STANDBY and TRANSMIT conditions.

11.4.1 Harmful Interference to Receiver (FCC 80.217 (a))

Limits

14 - 490 kHz: 5 μ V/m
490 kHz - 1 GHz: 1 μ V/m

Results

There is no spurious component which is deemed harmful interference.

11.4.2 Electromagnetic Field (FCC 80.217 (b)-1)

Limits

Below 30 MHz:	0.1 $\mu\text{V/m}$ at 1 nm (-20 dB $\mu\text{V/m}$)
30 to 100 MHz:	0.3 $\mu\text{V/m}$ at 1 nm (-10.5 dB $\mu\text{V/m}$)
100 to 300 MHz:	1.0 $\mu\text{V/m}$ at 1 nm (-0 dB $\mu\text{V/m}$)
Over 300 MHz:	3.0 $\mu\text{V/m}$ at 1 nm (9.5 dB $\mu\text{V/m}$)

Results

Interference was measured with the antenna located 2 m from the radar and converted to levels at 1 nm. There is no spurious component exceeding the limits.

11.4.3 Power Input to An Artificial Antenna (FCC 80.217 (b)-2)

Limits

Below 30 MHz:	400 $\mu\mu\text{W}$
30 to 100 MHz:	4,000 $\mu\mu\text{W}$
100 to 300 MHz:	40,000 $\mu\mu\text{W}$
Over 300 MHz:	400,000 $\mu\mu\text{W}$

Results

There is no spurious component exceeding the limits.

MEASUREMENT OF IMPEDANCE OF TEST ANTENNAS

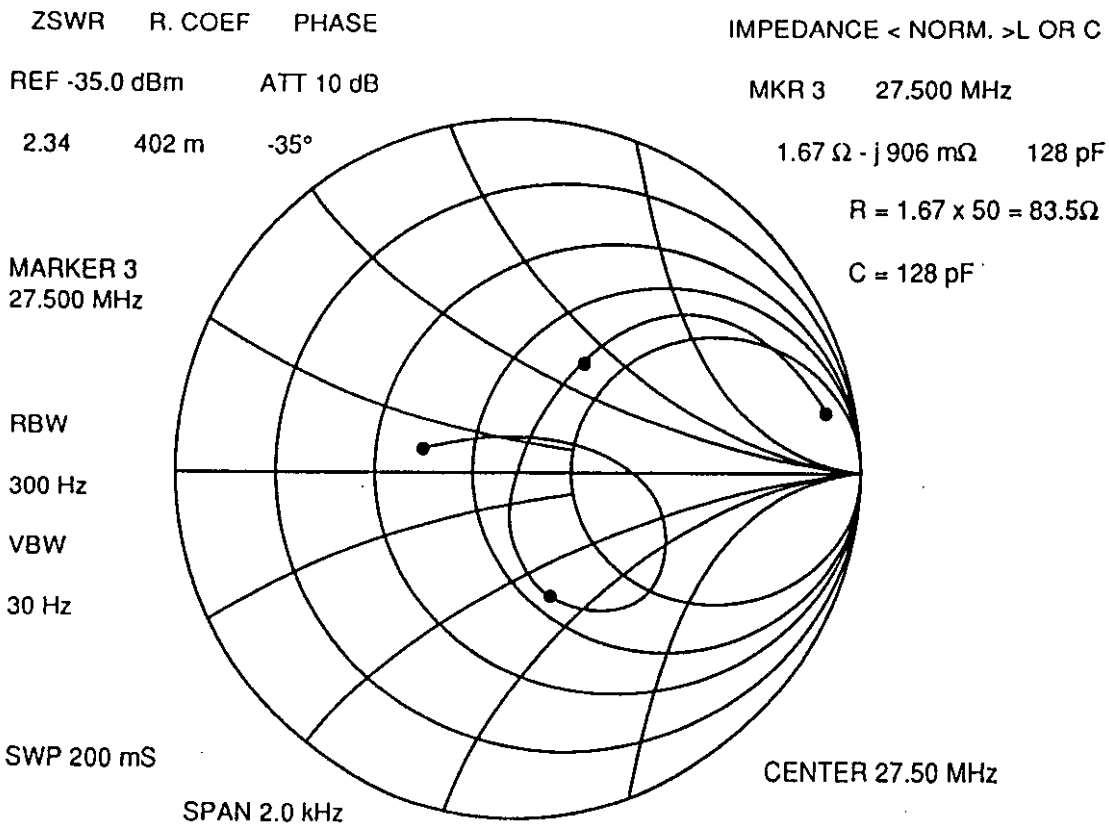
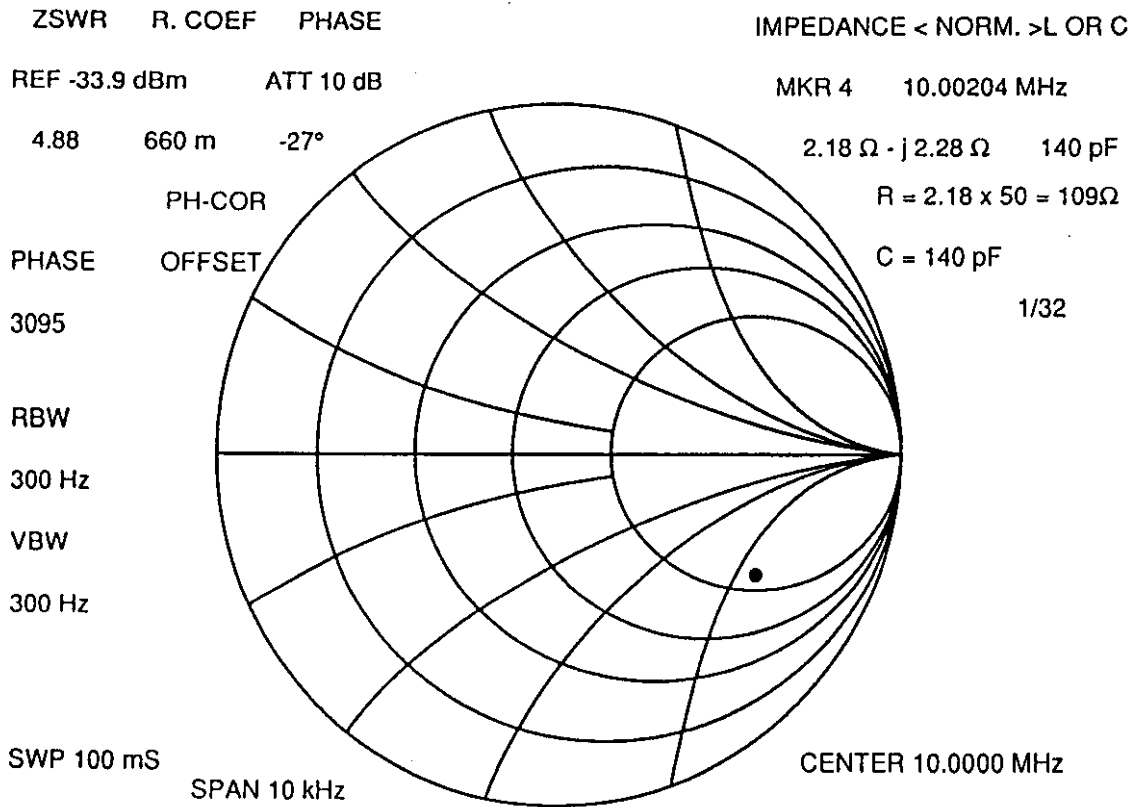

Band: 14kHz ~ 490kHz

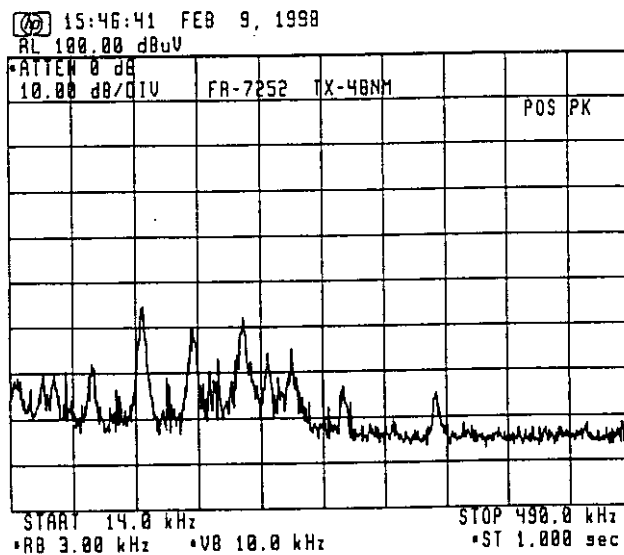
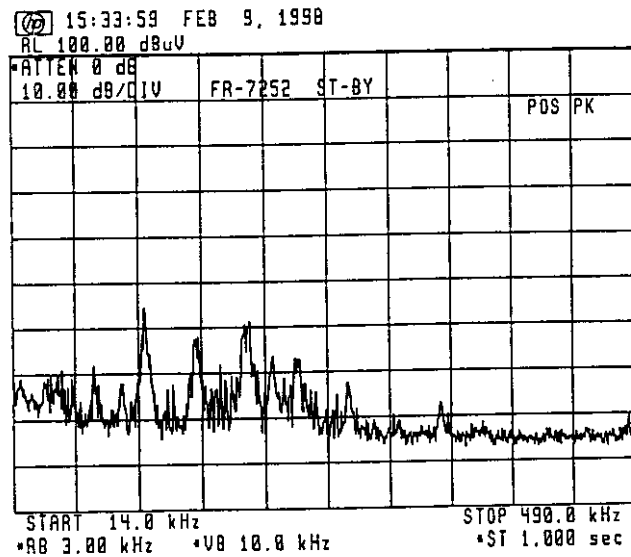
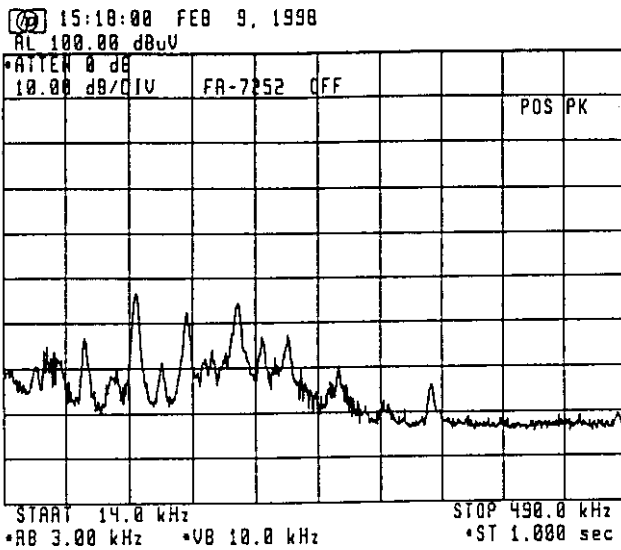

Band: 490kHz ~ 5MHz

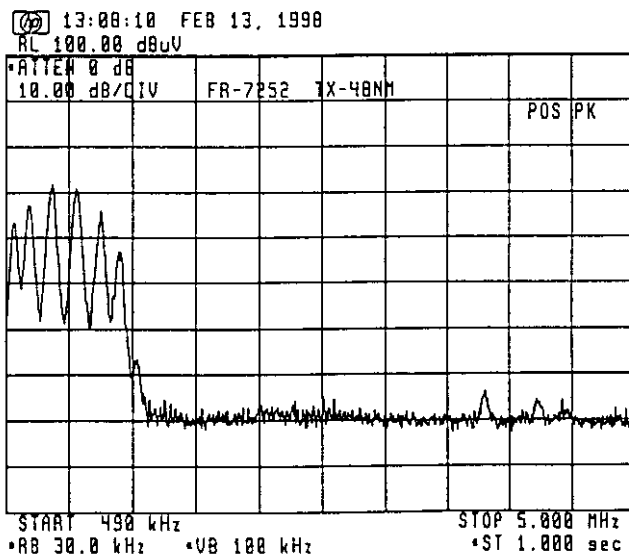
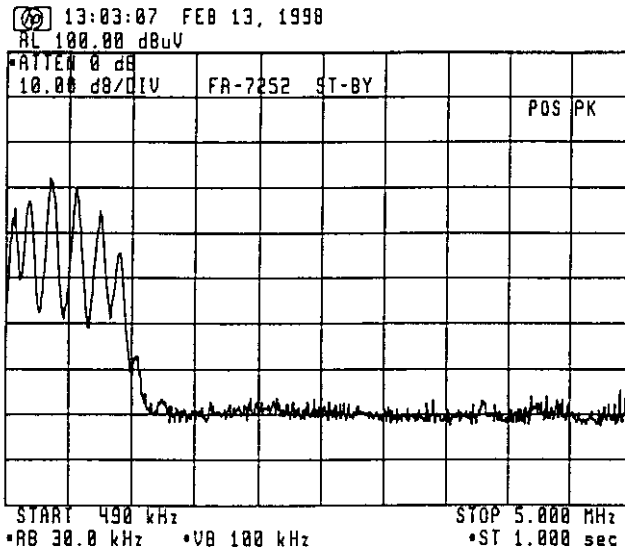
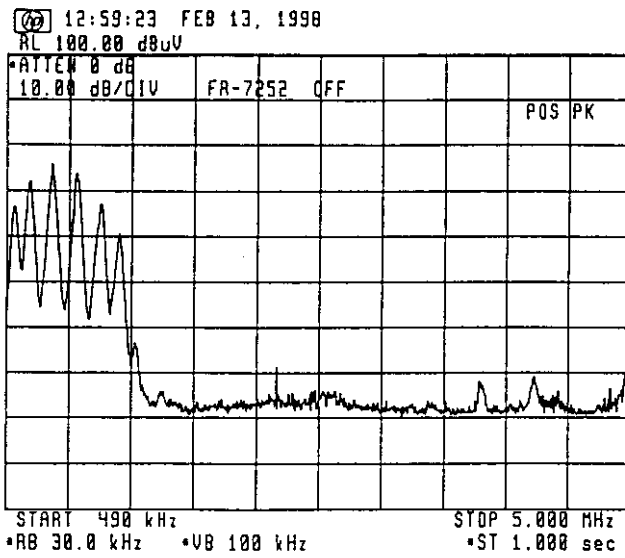

Band: 5MHz ~ 10MHz

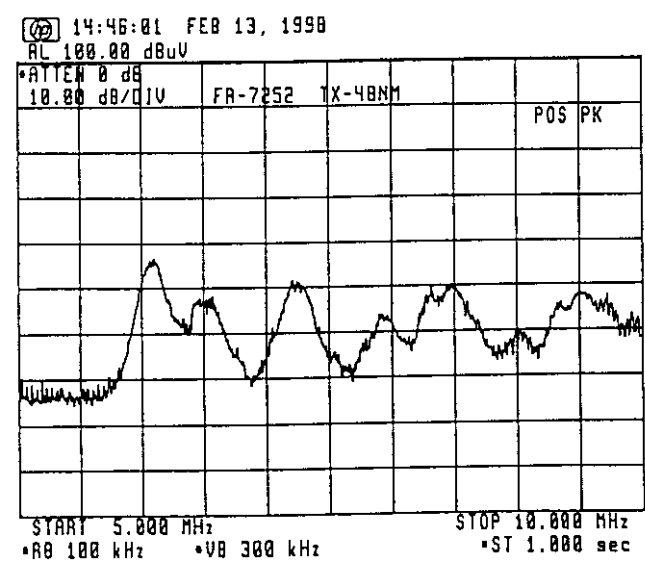
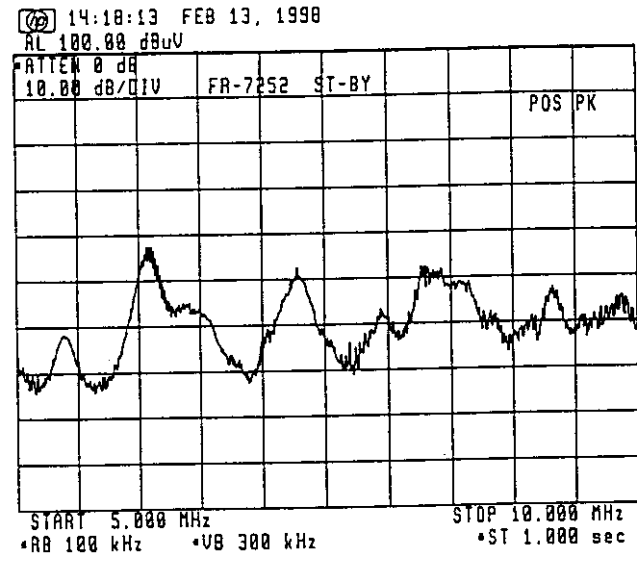
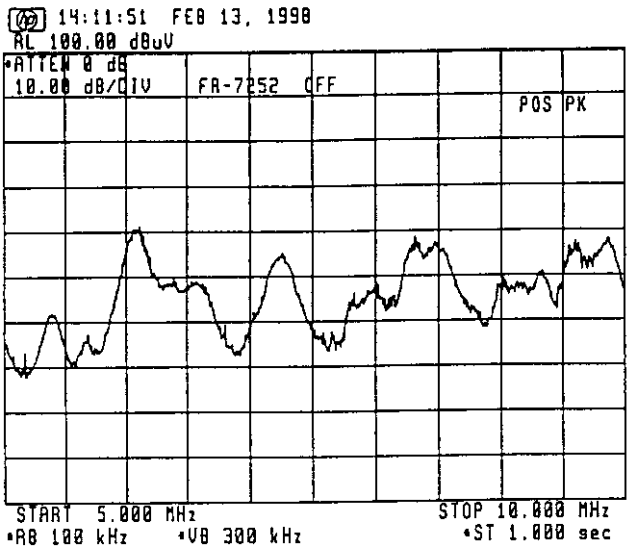

Band: 30MHz ~ 100MHz

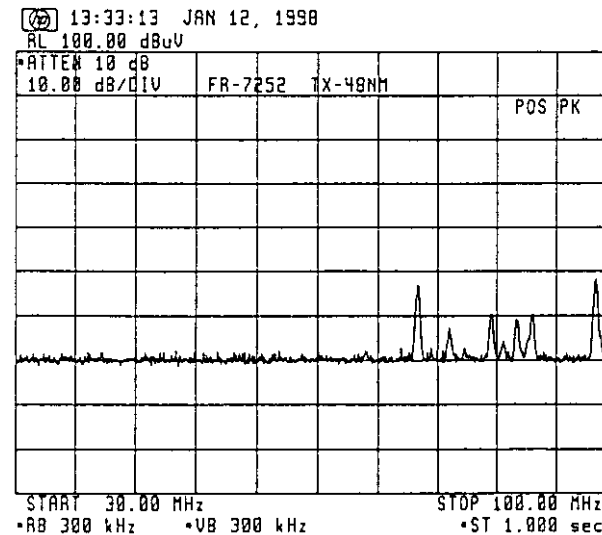
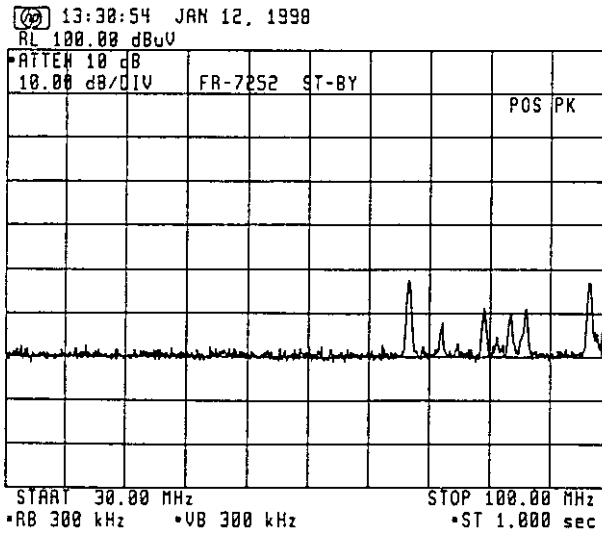
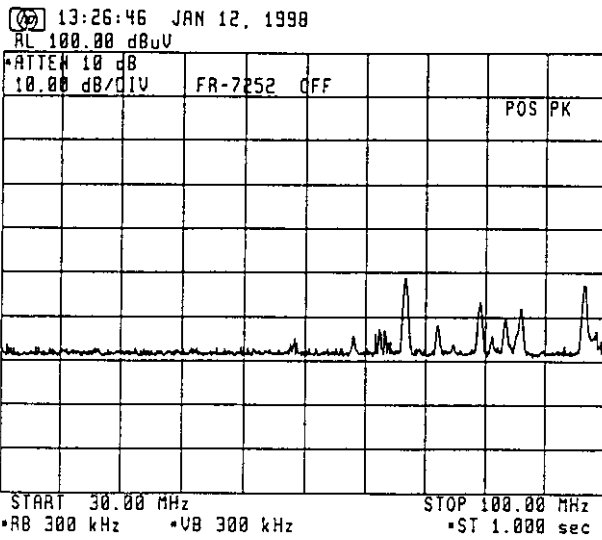

Band: 100MHz ~ 300MHz

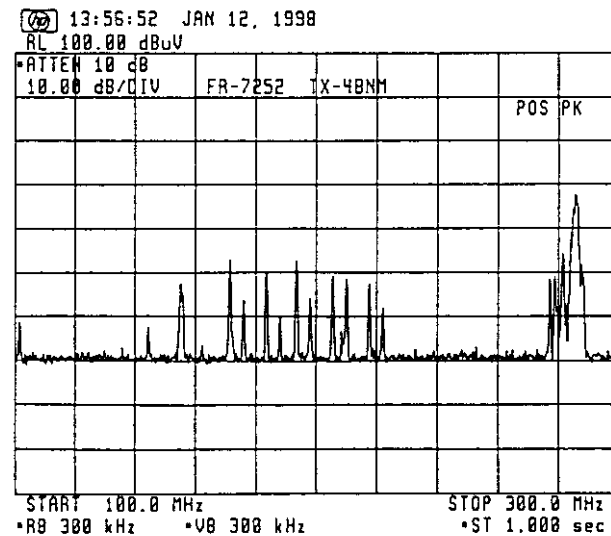
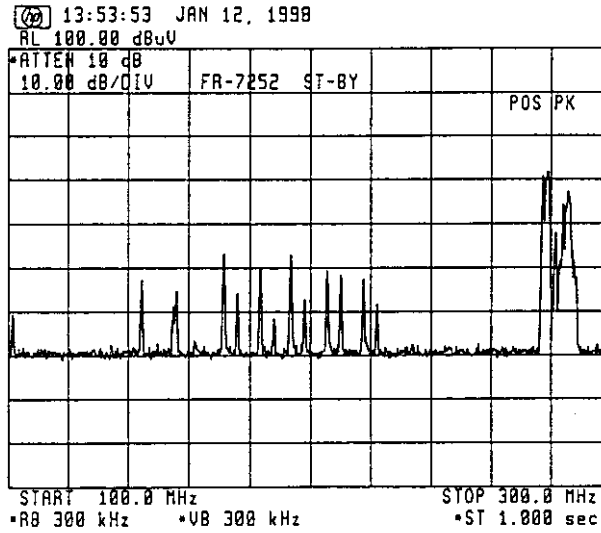
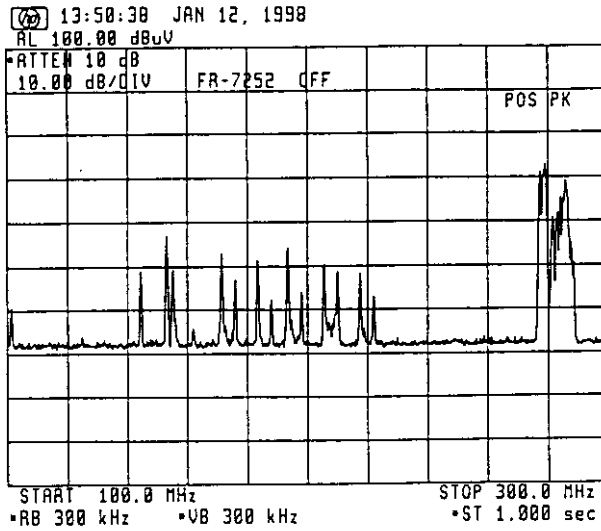

Band: 300MHz ~ 1GHz

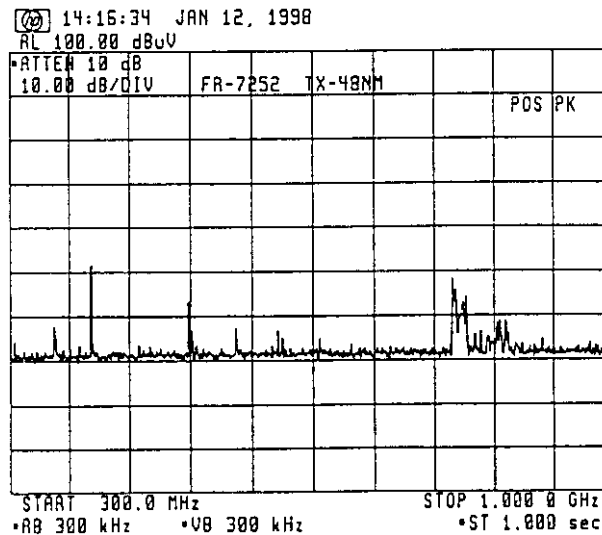
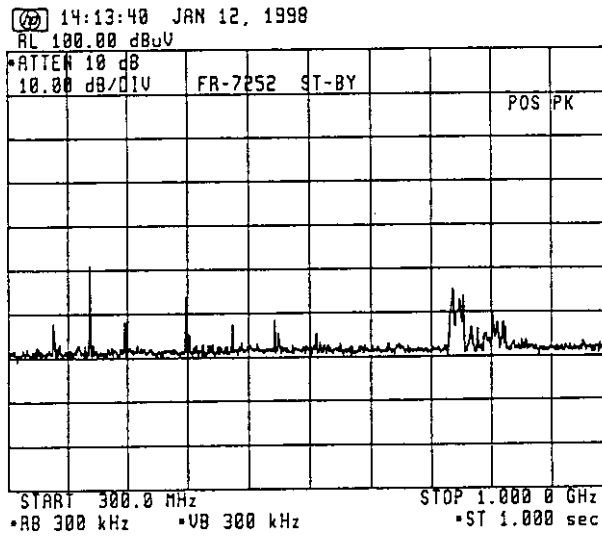
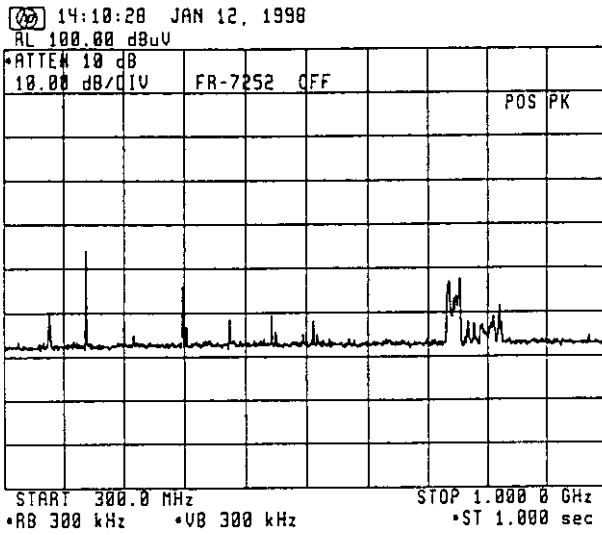

Band: 14kHz ~ 490kHz (Limit at 1N.M. = 0.1 μ V/m = -20 dB μ V/m)

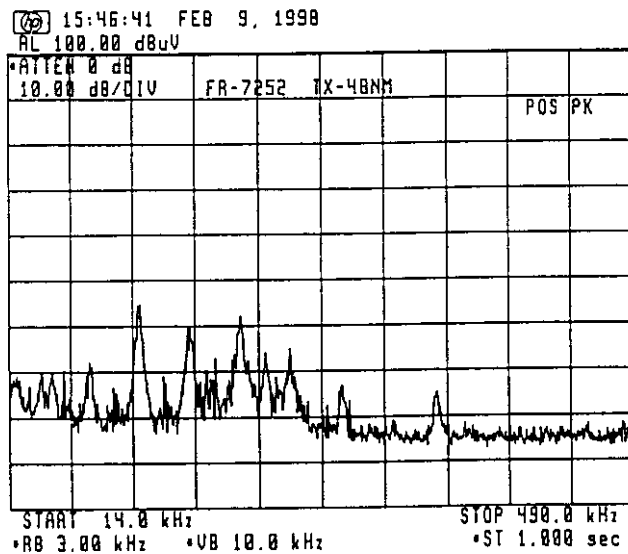
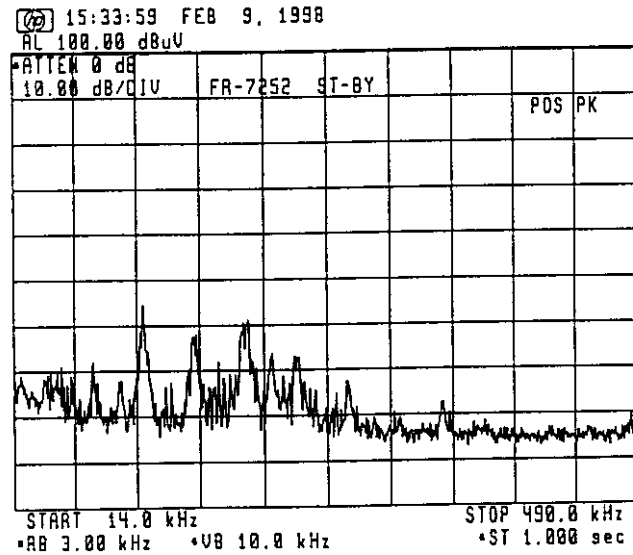
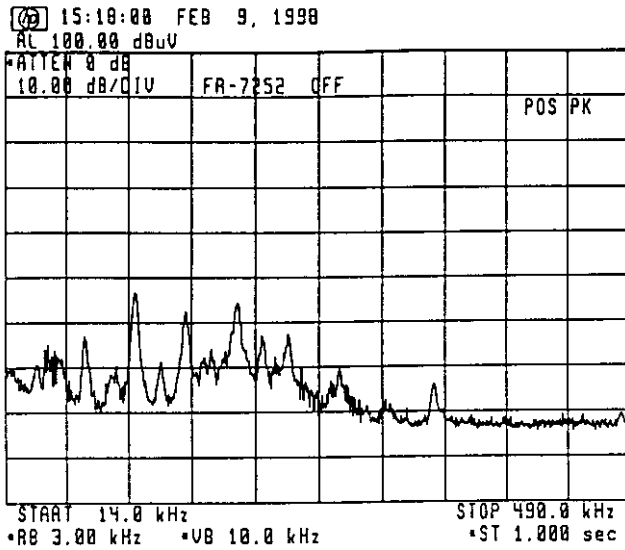

REF.
-26 dB μ V/m

Band: 490 kHz ~ 5 MHz (Limit at 1 N.M. = 0.1 μ V/m = -20 dB μ V/m)

12:59:23 FEB 13, 1998
RL 100.00 dBuV

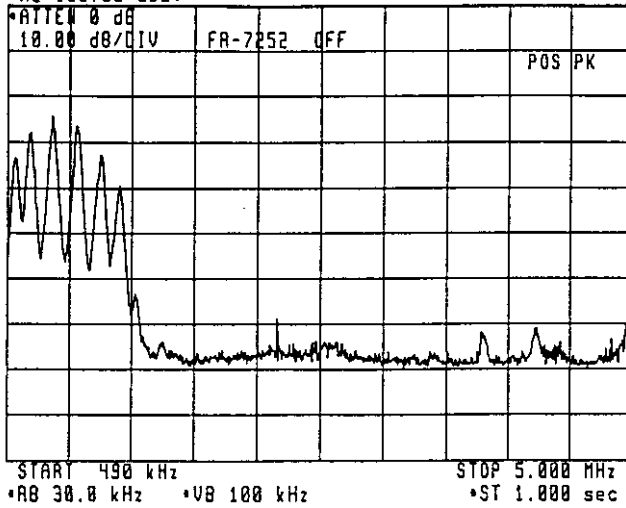

13:03:07 FEB 13, 1998
RL 100.00 dBuV

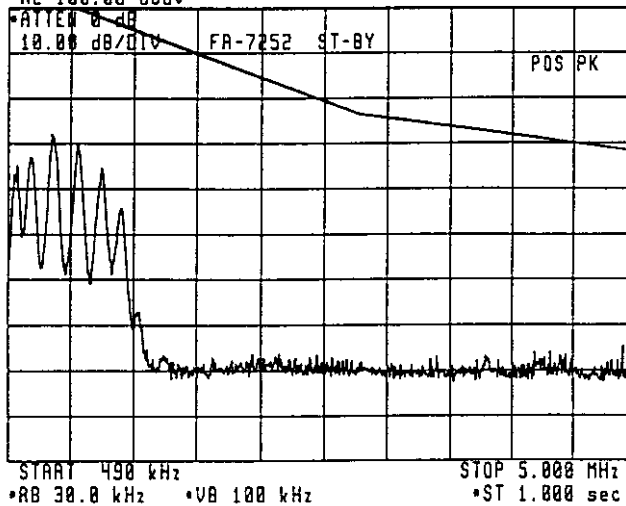

REF. (dB μ V/m)
100 - 126 = -26 (0.5 MHz)
100 - 96 = 4 (3 MHz)
100 - 88 = 12 (5 MHz)

-20 dB μ V/m

13:00:10 FEB 13, 1998
RL 100.00 dBuV

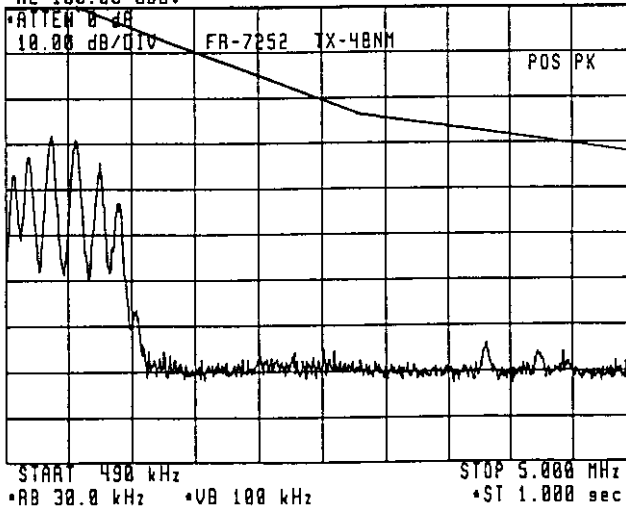

REF. (dB μ V/m)
100 - 126 = -26 (0.5 MHz)
100 - 98 = 4 (3 MHz)
100 - 88 = 12 (5 MHz)

-20 dB μ V/m

Band: 5MHz ~ 10MHz (Limit at 1N.M. = 0.1 μ V/m = -20dB μ V/m)

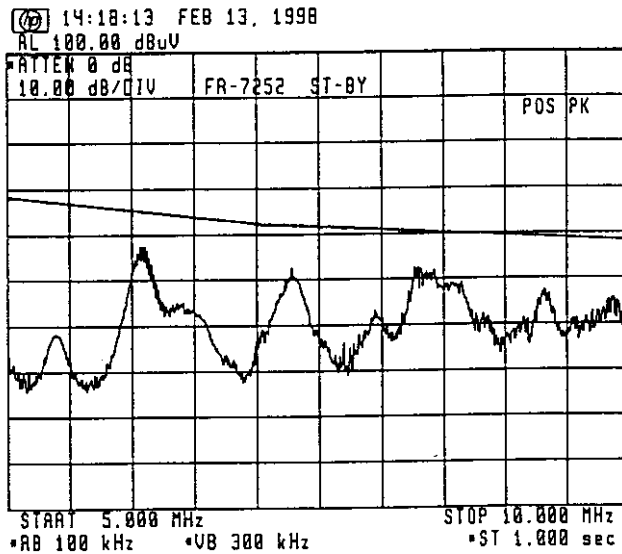
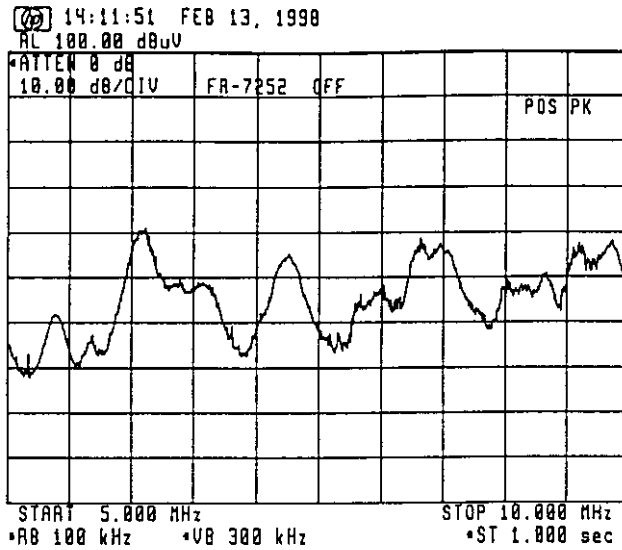

REF. (dB μ V/m)
100-88 = 12 (5MHz)
100-83 = 17 (7MHz)
100-78 = 22 (10MHz)

-20dB μ V/m

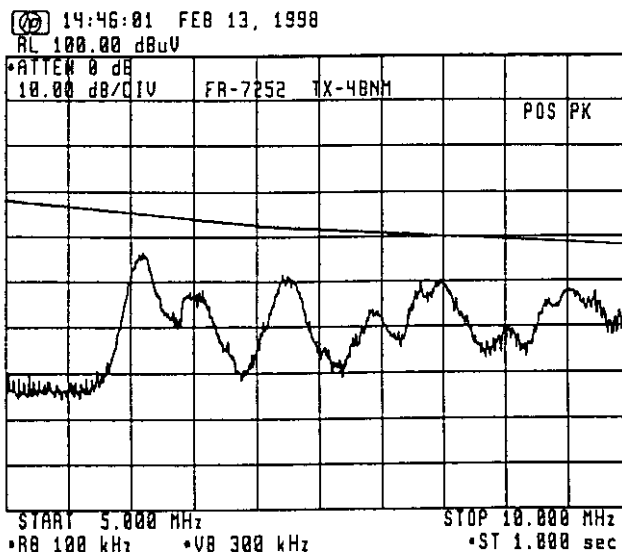

REF. (dB μ V/m)
100-88 = 12 (5MHz)
100-83 = 17 (7MHz)
100-78 = 22 (10MHz)

-20dB μ V/m

Band: 30MHz ~ 100MHz (Limit at 1N.M = 0.3 μ V/m = -10.5 dB μ V/m)

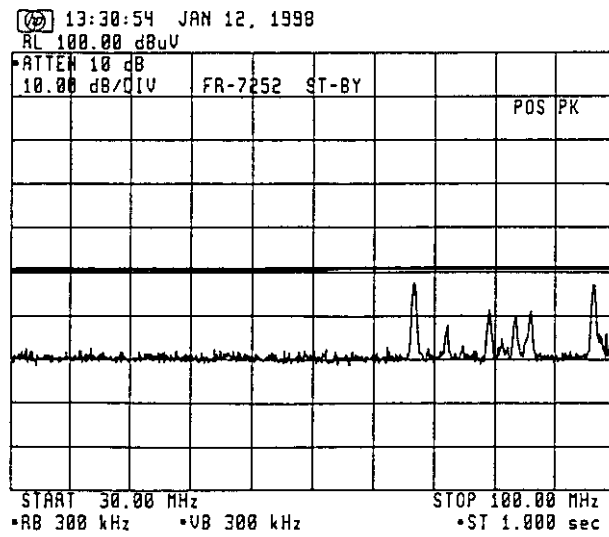
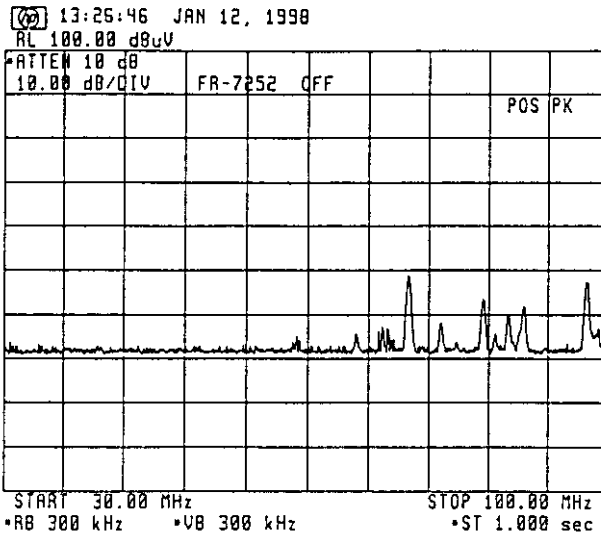

REF. (dB μ V/m)
 100 - 61 = 39

-10.5 dB μ V/m

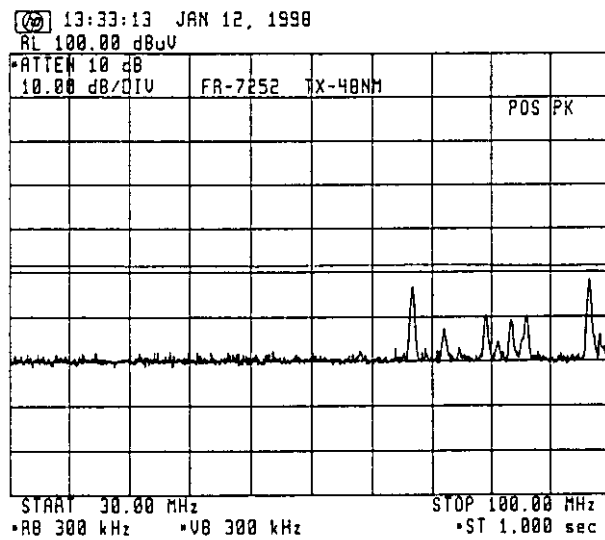

REF. (dB μ V/m)
 100 - 61 = 39

-10.5 dB μ V/m

Band: 100MHz ~ 300MHz (Limit at 1 N.M = 1 μ V/m = 0 dB μ V/m)

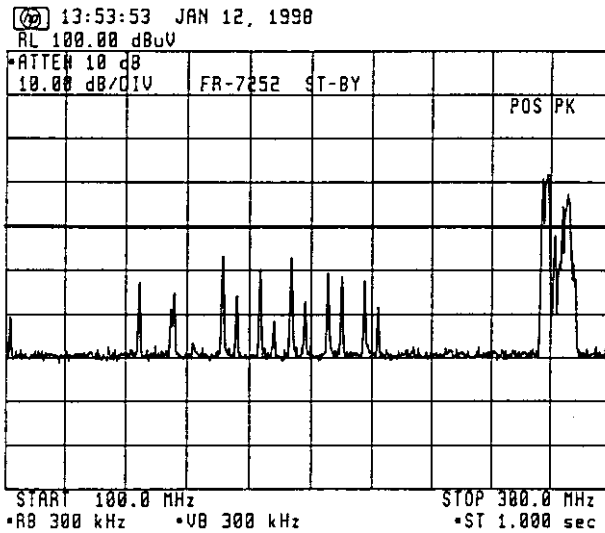
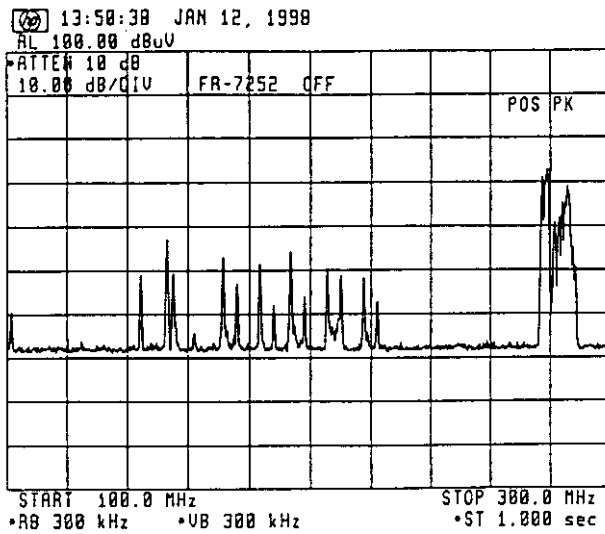

REF. (dB μ V/m)
 100 - 60 = 40

0 dB μ V/m

ALL COMPONENTS ABOVE
 THE LIMIT ARE FROM EXT-
 ERNAL NOISE OR SIGNALS,
 NOT FROM RADAR.

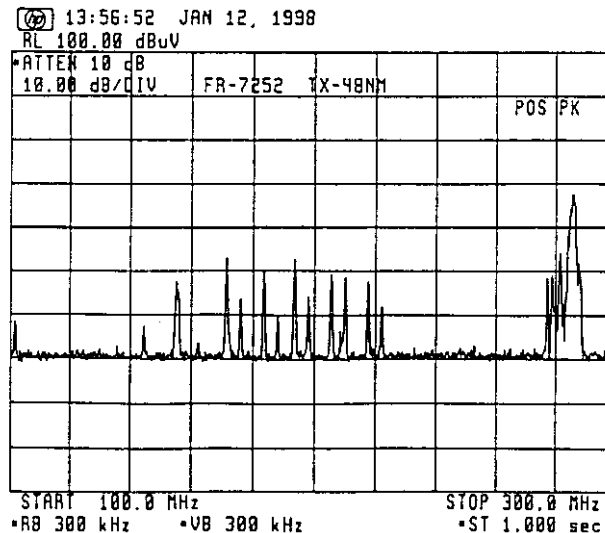

REF. (dB μ V/m)
 100 - 60 = 40

0 dB μ V/m

Band = 300MHz ~ 1GHz (Limit at 1N.M. = 3 μ V/m = 9.5dB μ V/m)

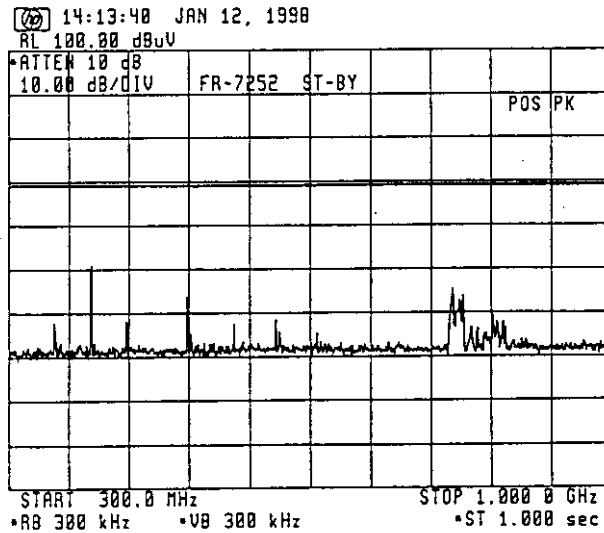
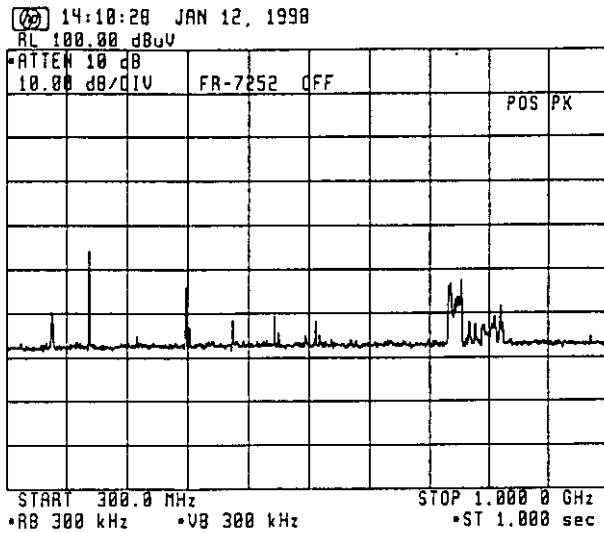

REF. (dB μ V/m)
 100 - 59.5 = 40.5

9.5dB μ V/m

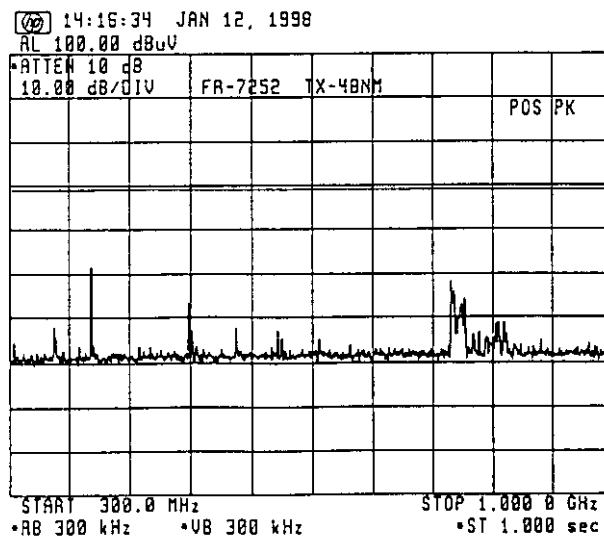

REF. (dB μ V/m)
 100 - 59.5 = 40.5

9.5dB μ V/m

Band: 14kHz ~ 490kHz (Limit at 2meter = -81dBm)

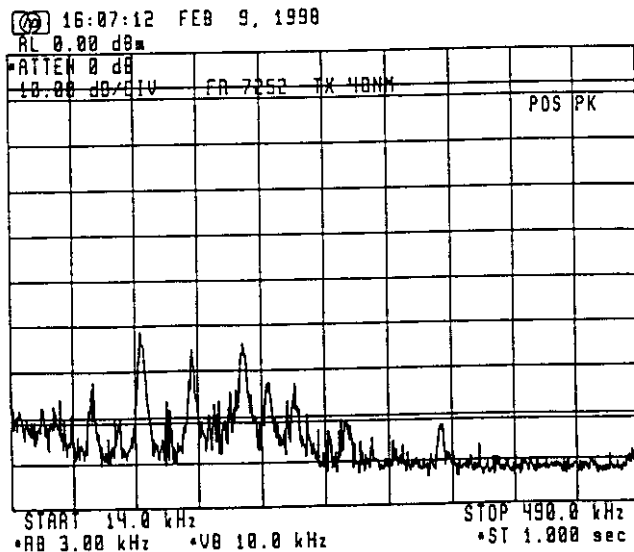
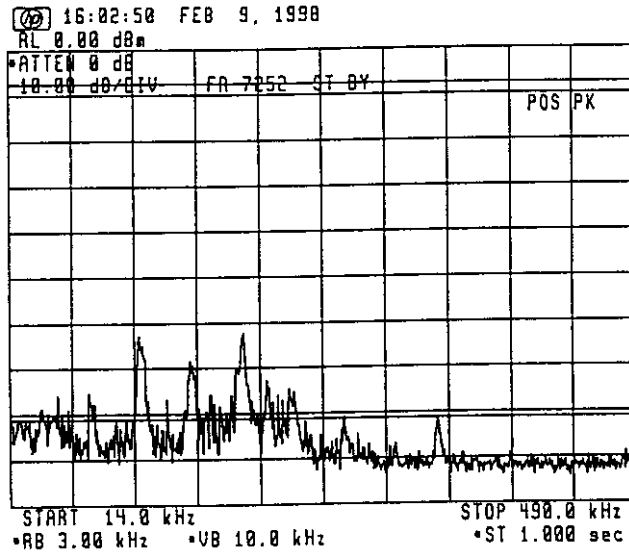
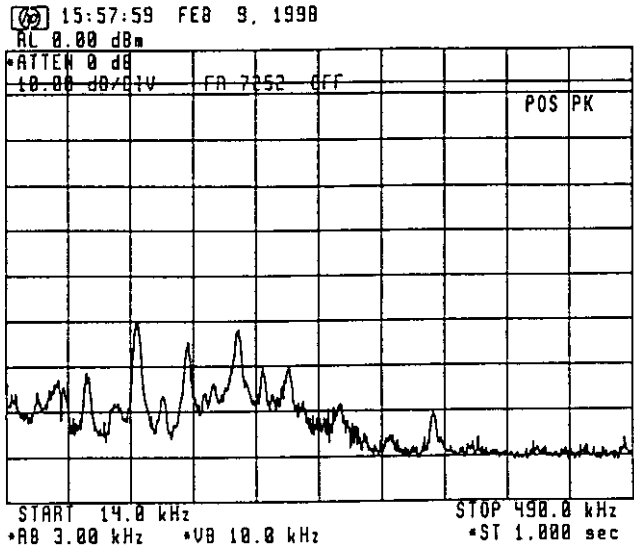

Band = 490kHz ~ 5MHz (Limit at 2 meter = -81dBm)

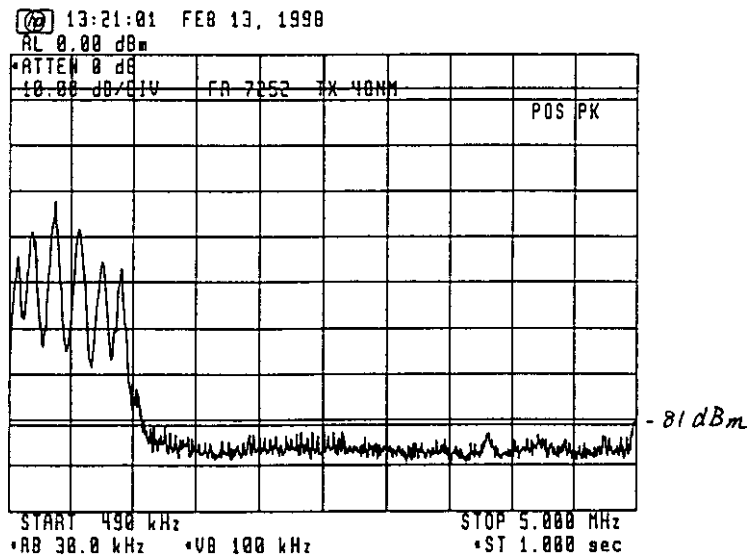
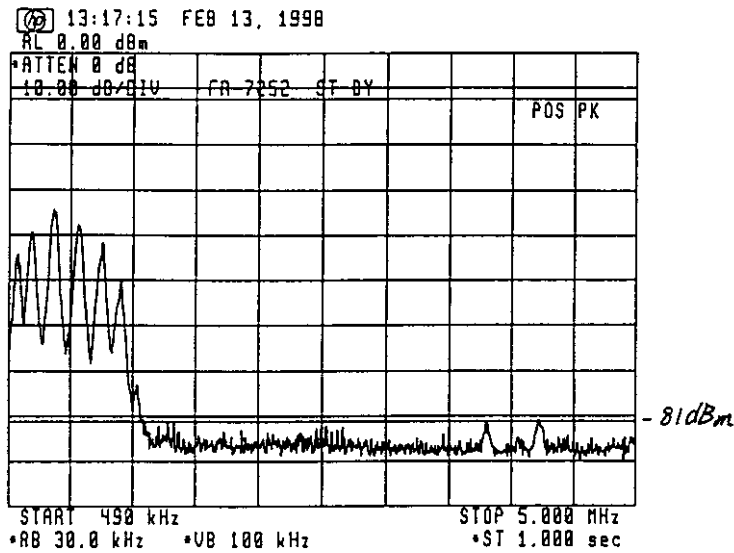
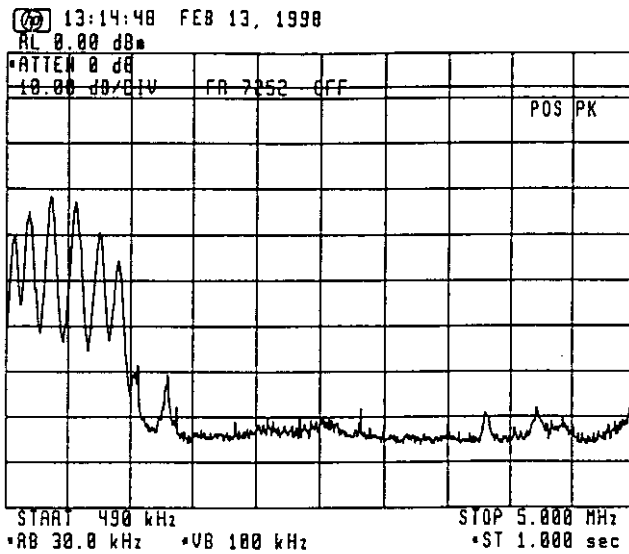

Band: 5MHz ~ 10MHz (Limit at 2meter = -81dBm)

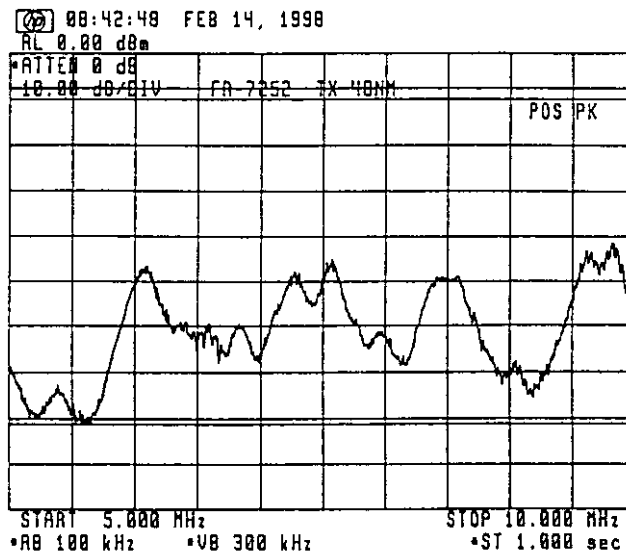
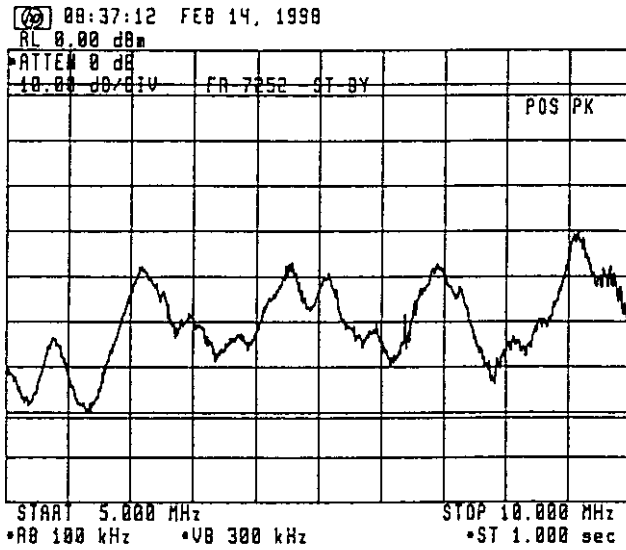
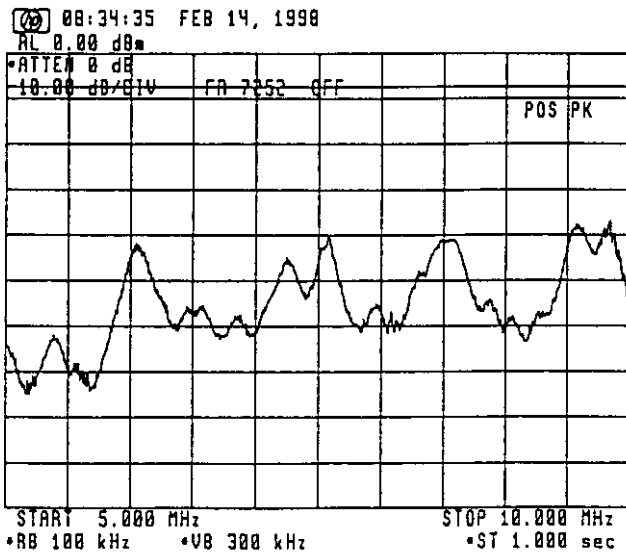

Band: 10MHz ~ 30MHz (Limit at 2 meter = -81dBm)

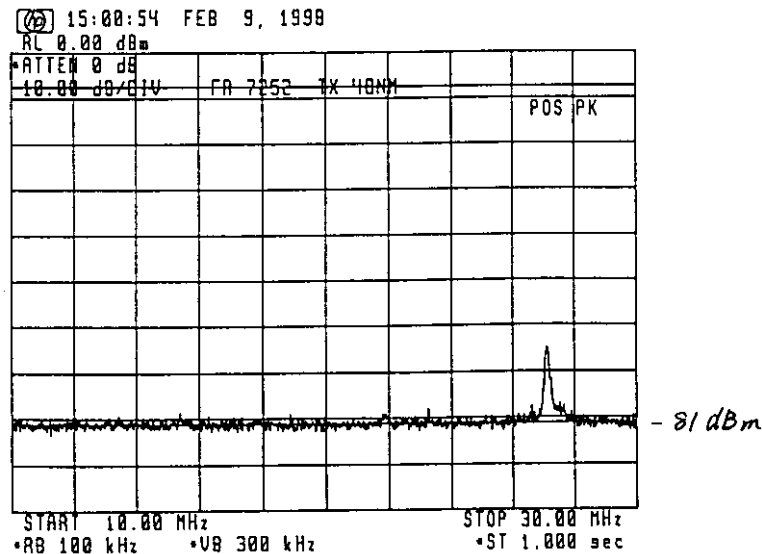
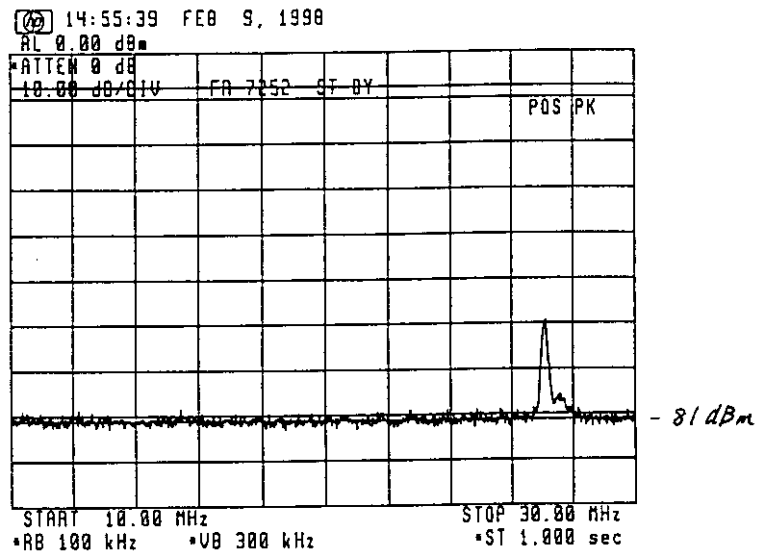
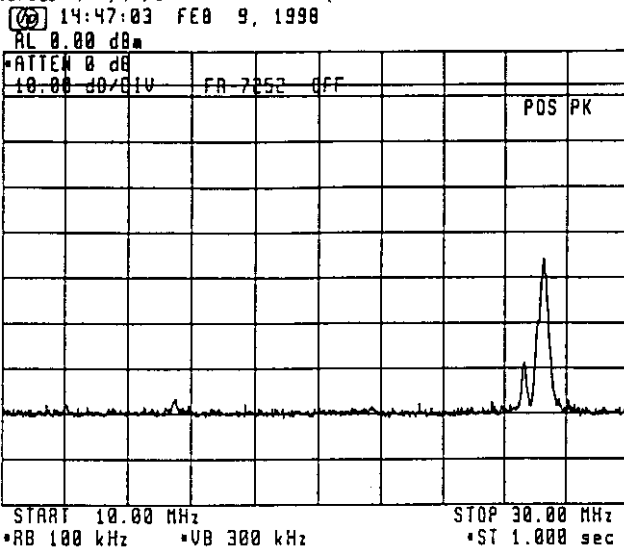

Band: 30MHz ~ 100MHz (Limit at 2 meter = -71dBm)

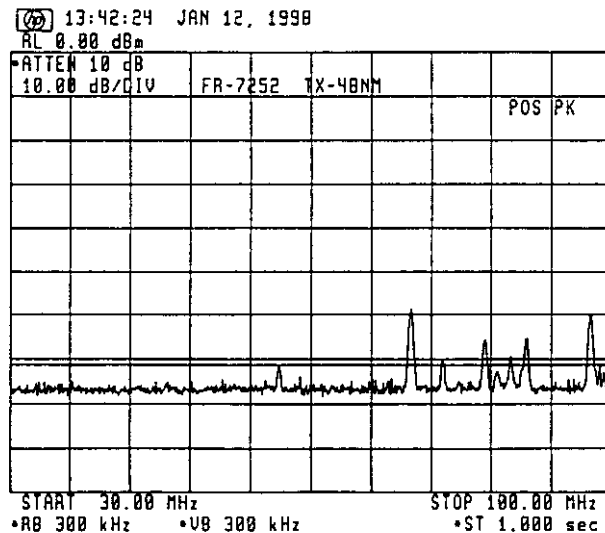
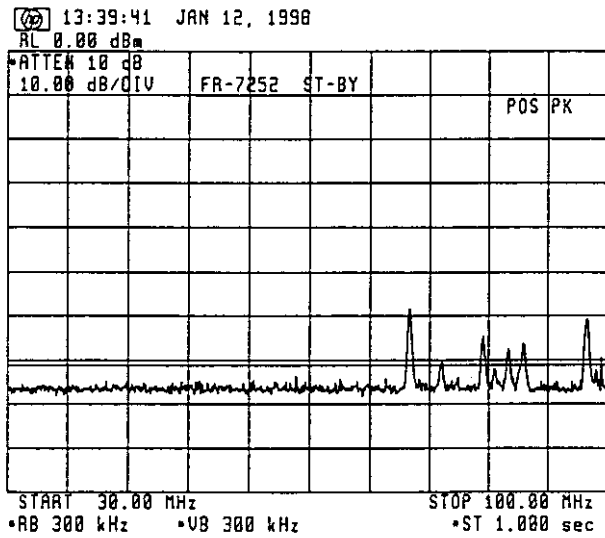
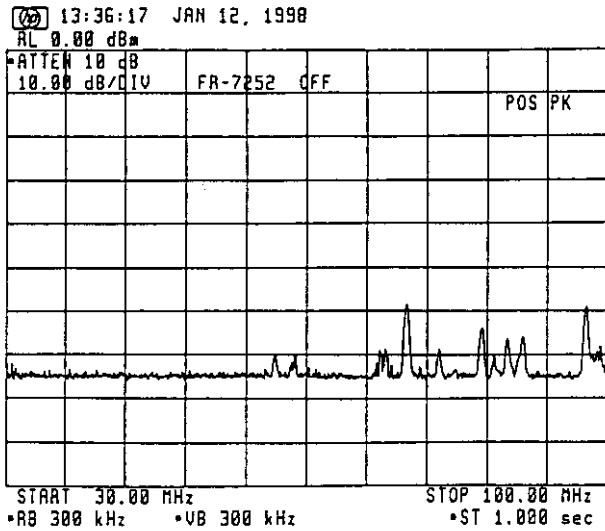

Band: 100MHz ~ 300MHz (Limit at 2 meter = -61dBm)

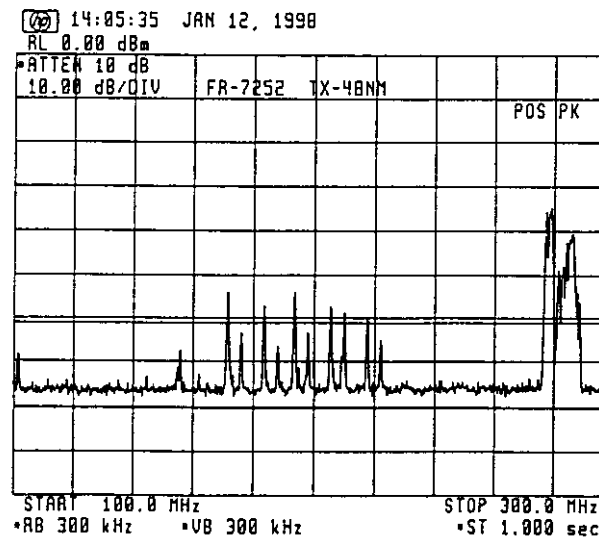
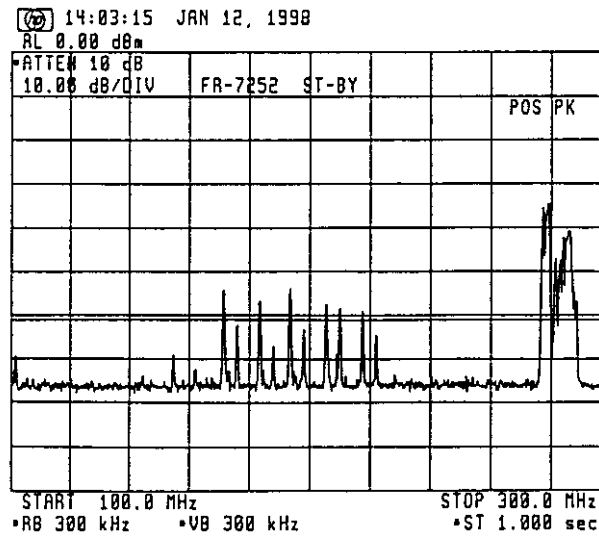
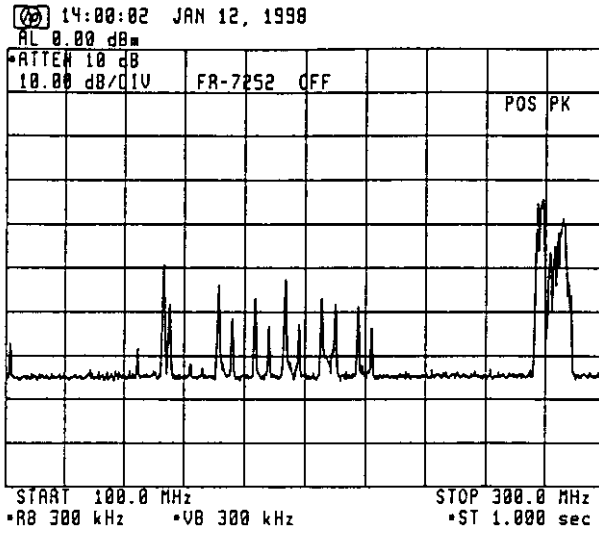

Band: 300MHz ~ 1GHz (Limit at meter = -51dBm)

