

*Furuno Labotech International Co., Ltd.*

*9-52 Ashihara-cho, Nishinomiya City,*

*Hyogo 662-8580, Japan*

*Tel. : +81-798-63-1094 Fax. : +81-798-63-1098*

# Test Report (Technical Information) for FCC T/A Application

Report No. : FLI 12-98-011

Client's name: Furuno Electric Co., Ltd.  
Radio Navigation & Communication Section 2  
Ashihara-cho 9-52, Nishinomiya-city, 662-8580 Japan.

Client's request no. : n/a

Equipment under test	Brand : FURUNO
	Model/Name : MARINE RADAR
	Type : Model 1942 MARK-2
	Serial no.: 3380-0101

Date of issue: July 1, 1998

(FLI Filing No. : FLI 04-98-110)

This report shall not be reproduced except in full, without the written approval of Furuno Labotech International Co., Ltd.

**Note : This sheet is for internal use only. Don't attach to FCC T/A application documents.**

Pub. No. : TI-1696

Date : July, 1998

# FURUNO®

## **TECHNICAL INFORMATION**

**TEST REPORT ON THE PERFORMANCE OF  
MARINE RADAR**

---

**MODEL 1942 MARK-2**

FURUNO ELECTRIC CO., LTD.  
NISHINOMIYA CITY, JAPAN

Pub. No. : TI-1696

Date : July, 1998

July 1, 1998

All data herein contained is true and correct to my best knowledge.



T. Yoshihara  
Manager  
Radio Navigation & Communication Section 2  
Research & Development Department  
Marine Product Division  
FURUNO ELECTRIC CO., LTD.

#### Personal History

Born: January 29, 1944

Graduated: Osaka University  
Electric Engineering Faculty

Occupation: Joined FURUNO ELECTRIC CO., LTD. in April 1967, since then engaged in the development of radar equipment.

\*\*\*\*\* C O N T E N T S \*\*\*\*\*

<b>1 GENERAL INFORMATION.....</b>	<b>4</b>
<b>2 IDENTIFICATION OF EQUIPMENT .....</b>	<b>10</b>
<b>3 RF POWER OUTPUT .....</b>	<b>11</b>
<b>4 MODULATION CHARACTERISTICS .....</b>	<b>14</b>
<b>5 OCCUPIED BANDWIDTH .....</b>	<b>19</b>
<b>6 SPURIOUS EMISSIONS AT ANTENNA TERMINAL .....</b>	<b>21</b>
<b>7 FIELD STRENGTH OF SPURIOUS RADIATION .....</b>	<b>25</b>
<b>8 FREQUENCY STABILITY .....</b>	<b>29</b>
<b>9 SUPPRESSION OF INTERFERENCE ABOARD SHIPS .....</b>	<b>32</b>
<b>10 PHOTOGRAPHS TO REVEAL EQUIPMENT CONSTRUCTION AND LAYOUT.....</b>	<b>38</b>
<b>11 TECHNICAL DESCRIPTION OF EQUIPMENT .....</b>	<b>46</b>
11.1 FUNCTION OF EACH SEMICONDUCTOR OR ACTIVE DEVICE .....	46
11.2 DESCRIPTION OF THE CIRCUITS EMPLOYED FOR SUPPRESSION OF SPURIOUS RADIATION, FOR LIMITING OR SHAPING THE CONTROL PULSE, AND FOR LIMITING OR CONTROLLING POWER.....	49
<b>12 OPERATOR'S MANUAL INCL. CIRCUIT DIAGRAMS .....</b>	<b>52</b>
Attachment 1 [ Test data for <u>6. Spurious Emissions at Antenna Terminal</u> ] .....	A1
Attachment 2 [ Test data for <u>7. Field Strength of Spurious Radiation</u> ] .....	A2
Attachment 3 [ Test data for <u>9. Suppression of Interference Aboard Ships</u> ] .....	A3
Attachment 4 [ List of Test/Measuring Equipment ] .....	A4

## 1 GENERAL INFORMATION

### 1.1 General

- (a) Manufacturer: Furuno Electric Co., Ltd.  
Ashihara-cho 9-52, Nishinomiya-city, 662-8580 Japan
- (b) Model: Model 1942 MARK-2  
Serial no.: 3380-0101
- (c) Primary Function: Search, navigation and anticollision
- (d) Maximum Range Scale: 64 nm
- (e) Discrimination  
Range Discrimination: less than 35 meters on a range scale of 1.5 nm  
Bearing Discrimination: Better than 2.5 ° on a range scale of 1.5 nm
- (e) Minimum Range: less than 35 meters on a range scale of 0.25 nm
- (f) Frequency Range: Fixed frequency, X-band  
Type of Emission: P0N
- (g) Power Supply: 12/24/32 VDC

### 1.2 Transmitter

- (a) Assignable Frequency for Shipborne Radar:  
Between 9300 and 9500 MHz (FCC Rule § 80.375 (d)-(1))
- (b) Type of RF Generator  
Magnetron Type: MG5389 or E3560  
Peak Output Power: 6 kW nominal
- (c) Magnetron Ratings  
Center frequency of Magnetron: 9410 MHz  
Tolerances
- |   | <u>MG5389</u> | <u>E3560</u> |
|---|---------------|--------------|
| Manufacturing:                                | ±30 MHz       | ±30 MHz      |
| Pulling:                                      | 23 Mhz        | 18 MHz       |
| Tolerance for 20° C<br>temperature variation: | 5 MHz         | 5 MHz        |
- (d) Guard Band:  
Guard Band is specified to be equal to 1.5/T MHz, where "T" is the pulselength in microseconds. See para (e). (FCC Rule § 80.209)

(e) Pulse Characteristics:

Pulse Type	Short	Middle	Long
Range Scale (nm)	0.125		
	<u>0.25</u>		
	0.5		
	0.75		
	1		
	1.5	<u>1.5</u>	
		2	
		3	3
			4
			6
			8
		12	
		16	
		24	
		36	
		48	
		64	
Output pulselength ( $\mu$ s)	0.08	0.30	0.80
P.R.R. (Hz)	2100	1200	600
Duty cycle	1.68E-4	3.60E-4	4.80E-4
Guard Band (MHz)	18.75	5.00	1.88

Note: Tests were carried out for the underlined Range Scales.

1.3 Modulator

- (a) FET Type: 2SK1450  
 Trigger Voltage: Approx. +20 VDC

1.4 Receiver

- (a) Passband  
 IF Stage:

Pulse Type	Short	Middle	Long
(MHz)	25	25	3

- (b) Gain (overall) (dB): Sufficient to cause limiting, approximately 130
- (c) Overall Noise Figure ( dB): 6 (typical)
- (d) Video Output Voltage (V): 0.7 positive across 75 ohms
- (e) Features Provided: Sensitivity Time Controls (Anti-clutter Sea),  
Fast Time Constant (Anti-clutter Rain)
- (f) If receiver is tunable, describe method of adjusting frequency:  
Adjustment of tuning voltage of receiver local oscillator (Automatic and manual)

**1.5 Display**

- (a) Type: 10 (in.) mono-color(green),  
PPI, raster scan.
- (b) Size of Indicator Tube: 10 in. diagonal CRT  
effective dia., 130 mm
- (c) Sweep Linearity: 2 % on all ranges
- (d) Range Scales:

Range (nm)	Number of Range Rings	Range Ring Interval (nm)
0.125	2	0.0625
0.25	2	0.125
0.5	4	0.125
0.75	3	0.25
1	4	0.25
1.5	3	0.5
2	4	0.5
3	3	1
4	4	1
6	3	2
8	4	2
12	4	3
16	4	4
24	4	6
36	3	12
48	4	12
64	4	16

- (e) Range Ring Accuracy: Better than 0.9 % of maximum scale in use  
or 8 m, whichever is the greater

- (f) Overall Bearing Accuracy from Scanner to Display:  
Better than 1°
- (g) Target Plot Facility: Simulated afterglow in low shade
- (h) Heading Indicator: Provided, automatic alignment.
- (i) True Bearing Indicator: Provided.

**1.6 Antenna**

- (a) Antenna Rotation ON-OFF Switch:  
Not provided.
- (b) Reflector: Slotted waveguide array,

Radiator Type	XN12A
Length (cm)	120
Length (ft)	4

- (c) Type of Beam: Vertical fan
- (d) Beam Width (between half-Radiator power points)

Radiator Type	XN12A
Horizontal	1.90 °
Vertical	22 °

- (e) Polarization: Horizontal

- (f) Antenna Gain:

Radiator Type	XN12A
(dB)	28

- (g) Attenuation of Major Side Lobes with respect to main beam:  
Within  $\pm 20^\circ$  , 24 dB  
Outside  $\pm 20^\circ$  , 30 dB
- (h) Scanning (rotating or oscillating): Rotating over 360° continuously  
clockwise
- (i) Antenna Rotation Rate: 24 rpm ( for RSB-0070)  
48 rpm ( for RSB-0073)
- (j) Number of Degrees Scanned: 360°
- (k) Sector Scan: Not provided. Sector blanking available.
- (l) Type of Transmission System: Contained in scanner unit
- (m) Rated Loss of Transmission System per hundred feet:  
None. Transmission path is only in the antenna scanner unit.



**1.7 Line Power Supply Requirements**

- (a) Input Voltage: 12/24/32 VDC
- (b) Power Drain: 64 W

**1.8 Functional Controls**

- |                                 |                        |                            |
|---------------------------------|------------------------|----------------------------|
| *Range selector                 | *Tune (manual)         | *EBL offset                |
| *Power save                     | *Anti-clutter auto     | *Power Switch              |
| *A/C Sea control                | *Gain control          | *Panel dimmer              |
| *Heading line off               | *Echo stretch          | *MENU                      |
| *Guard zone set/Audio alarm off | *Range ring brilliance | *Noise rejector on/off     |
| *Interference rejector          | *STBY/TX               | *Trackball (VRM,EBL,GUARD) |
| *VRM on/off                     | *Off-center (SHIFT)    | *A/C Rain control          |
| *Range set                      | *Zoom                  | *EBL on/off                |
| *Target trail                   | *Brilliance (screen)   | *TRU/REL                   |
| *Navigation on/off              | *Mark Brilliance       | *Function #1 - #2          |
| *Range ring on/off              | *Text Brilliance       | *HU/CU/NU/TM mode          |
| *ARPA function(option)          | *Watchman              |                            |

**1.9 Construction Features**

- (a) Does equipment embody replacement units with chassis type assembly:  
Yes
- (b) Are fuse alarms provided: Fuses are provided.
- (c) State units which are weatherproof: Scanner Unit (IEC IPX6)
- (d) If all units are not housed in a single container, indicate number and give description of individual units:

1 × Display Unit	Type:	RDP-118
1 × Scanner Unit	Type:	RSB-0070 (24 V, 24 rpm)
		RSB-0073 (24 V, 48 rpm)
(Transceiver	Type:	RTR-059 (contained in the Scanner unit))
- (e) Approximate Weight of Complete Installation:

Display Unit:	8 kg	
Scanner Unit:	23 kg	( XN12A-RSB-0070/73 )
- (f) Approximate space required for installation excluding scanner:

Display Unit:	472 mm (W) X 298 mm (H) X 367 mm (D)
---------------	--------------------------------------

**Pub. No. : TI-1696**

**Date : July, 1998**

**1.10 Operational Features**

- (a) Is positive means provided to indicate whether or not the overall operation of the equipment is such that it may be relied upon to provide effective operation in accordance with its primary function:

Magnetron/Xtal checker

- (b) Is the equipment for continuous operation:

Yes

- (c) Is provision made for operation with shore based radar beacons (RACONS):

Yes (RACONS and SART)

## 2 IDENTIFICATION OF EQUIPMENT (FCC Rule § 2.925)

The following nameplates are permanently fixed on the corresponding equipment units.

FCC ID: ADB9ZW1942M2

Material of nameplate: Polyester, 0.1 mm thick

<b>MARINE RADAR</b>	
[REDACTED]	
<b>SCANNER UNIT</b>	
TYPE	RSB-0070
SER. NO.	R100-
COMPASS SAFE DISTANCE	
STD [REDACTED] M	STEER [REDACTED] M
EQUIPMENT CLASS [REDACTED]	
FURUNO ELECTRIC CO., LTD.	
NISHINOMIYA CITY, MADE IN JAPAN	

Fig. 2.1  
Nameplate for  
Scanner unit  
at RSB-0070

<b>MARINE RADAR</b>	
[REDACTED]	
<b>SCANNER UNIT</b>	
TYPE	RSB-0073
SER. NO.	R101-
COMPASS SAFE DISTANCE	
STD [REDACTED] M	STEER [REDACTED] M
EQUIPMENT CLASS [REDACTED]	
FURUNO ELECTRIC CO., LTD.	
NISHINOMIYA CITY, MADE IN JAPAN	

Fig. 2.2  
Nameplate for  
Scanner unit  
at RSB-0073

<b>MARINE RADAR</b>	
MODEL	1942 MARK-2
<b>DISPLAY UNIT</b>	
TYPE	RDP-118
INPUT	10.2 - 41.6 VDC
SER. NO.	3380 -
FCC ID: ADB9ZW1942M2	
FURUNO U.S.A., INC.	
COMPASS SAFE DISTANCE	
STD [REDACTED] M	STEER [REDACTED] M
EQUIPMENT CLASS [REDACTED]	
FURUNO ELECTRIC CO., LTD.	
NISHINOMIYA CITY, MADE IN JAPAN	

Fig. 2.3  
Nameplate for  
Display unit

### 3 RF POWER OUTPUT (FCC Rule § 2.985)

#### 3.1 Microwave characteristics

The peak voltage was determined using the divider having a ratio of 1000 to 1 and the oscilloscope. Current pulse was viewed across the wideband current transformer with output voltage per ampere 1.00.

##### Nominal values

Pulse Type	Short	Middle	Long
Range scale (nm)	0.25	1.5	64
Pulselength (μs)	0.08	0.30	0.80
PRR (Hz)	2100	1200	600
Duty cycle	1.68E-4	3.60E-4	4.80E-4
Guard band (MHz)	18.75	5.00	1.88

##### Measured values

Magnetron input pulse voltage was measured at its cathode using the oscilloscope and divider with ratio 1000 to 1.

Pulse Type	Short	Middle	Long
Directional coupler attenuation (dB)	40.67	40.67	40.67
Magnetron input voltage (kV)	4.50	4.35	4.35
Pulselength (μs) (50 % amplitude)	0.300	0.560	1.050
Rise time (μs) (10-90 % amplitude)	0.060	0.060	0.060
Decay time (μs) (90-10 % amplitude)	0.850	0.800	0.450

##### Magnetron input pulse current

Magnetron input pulse current was observed across the wideband current transformer with output voltage per ampere 1.00.

Pulse Type	Short	Middle	Long
Magnetron input current (A)	3.0	3.5	3.5

Pulse Type	Short	Middle	Long
Pulselength ( $\mu$ s) (50 % amplitude)	0.100	0.295	0.800
Rise time ( $\mu$ s) (10-90 % amplitude)	0.060	0.075	0.075
Decay time ( $\mu$ s) (90-10 % amplitude)	0.060	0.060	0.060

### RF envelope of the magnetron output pulse

The RF envelope of the magnetron output pulse was measured using a diode and the oscilloscope with the following results:

Pulse Type	Short	Middle	Long
Pulselength ( $\mu$ s) (-3 dB points)	0.102	0.300	0.800
Rise time ( $\mu$ s) (10-90 % amplitude)	0.017	0.020	0.020
Decay time ( $\mu$ s) (90-10 % amplitude)	0.060	0.060	0.060

### Estimated efficiency

The estimated efficiency of the RF generator (magnetron) was determined by the following measurements and calculation. Power output from magnetron was measured using the directional coupler, power meter and the oscilloscope.

Pulse Type	Short	Middle	Long
Range scale (nm)	0.25	1.5	64
PRR (Hz)	2234.7	1257.0	566.5
Duty cycle	2.27E-4	3.77E-4	4.53E-4
Magnetron input, av. (W)	3.08	5.74	6.90
Magnetron input, peak (kW)	13.50	15.23	15.23
Power meter reading (mW)	0.0927	0.161	0.210
Magnetron output, av. (W)	1.082	1.879	2.450
Spurious response limits (dB)	43.34	45.74	46.89
Magnetron Output, peak (kW):	4.75	4.98	5.41
Magnetron efficiency (%):	35.2	32.7	35.5

Pub. No. : TI-1696

Date : July, 1998

Peak Power Input to RF Generator : 14.65 kW

Estimated Efficiency of RF Generator : 34.5 %

## 4 MODULATION CHARACTERISTICS (FCC Rule §2.987)

### 4.1 FET Trigger Pulse

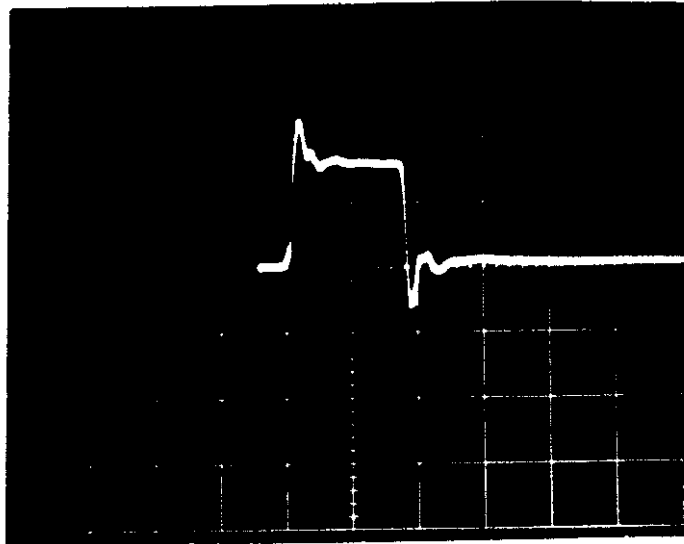

Fig. 4.1

(Typical wave form of Trigger Pulse)  
Short Pulse (0.25 nm Range)

Scale: 10 V/div.  
0.5  $\mu$ s/div.

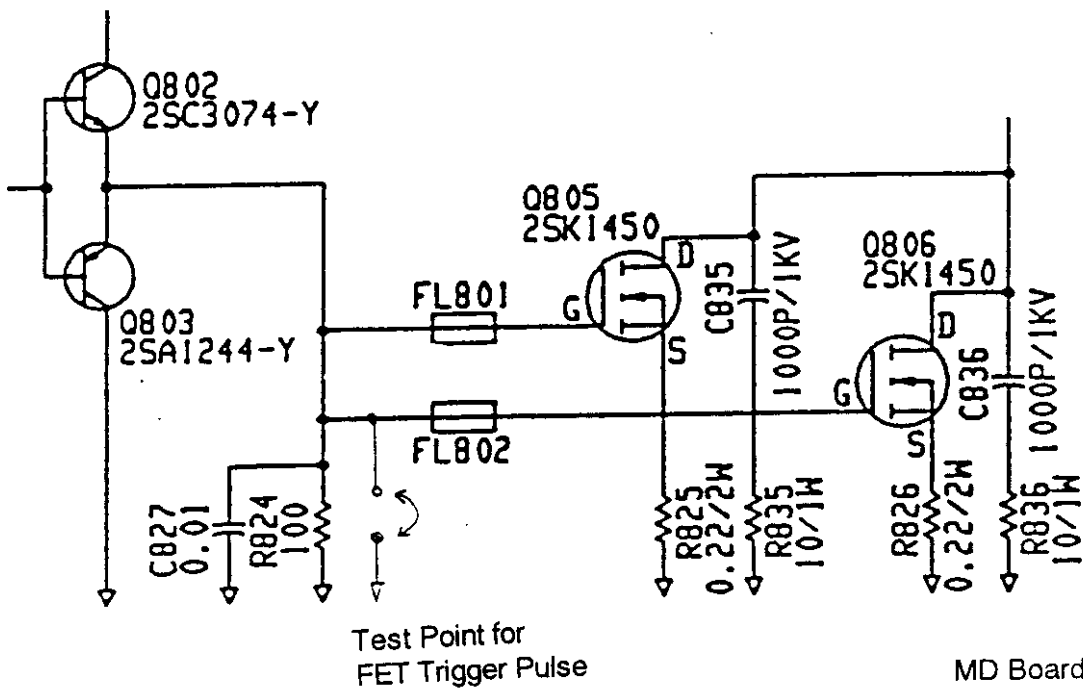

Fig. 4.1.2 Test Point for Trigger Pulse

### 4.2 Trigger Pulse at Magnetron Cathode

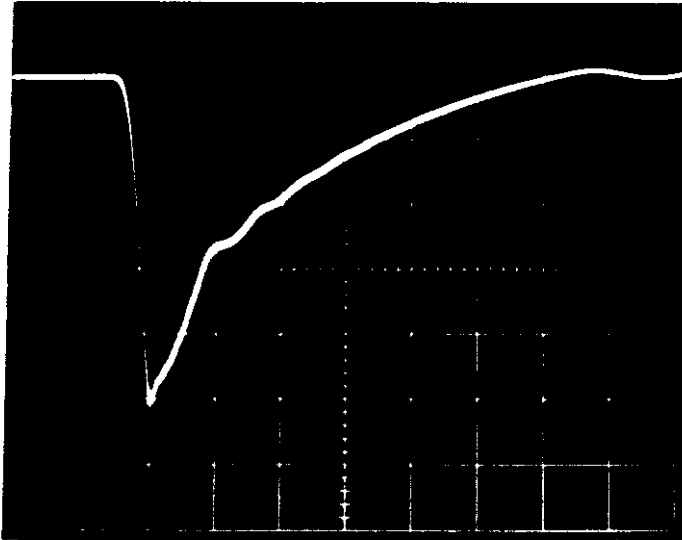

Fig. 4.2.1 Short Pulse (0.25 nm Range)

Scale: 1 kV/div. 0.2  $\mu$ s/div.

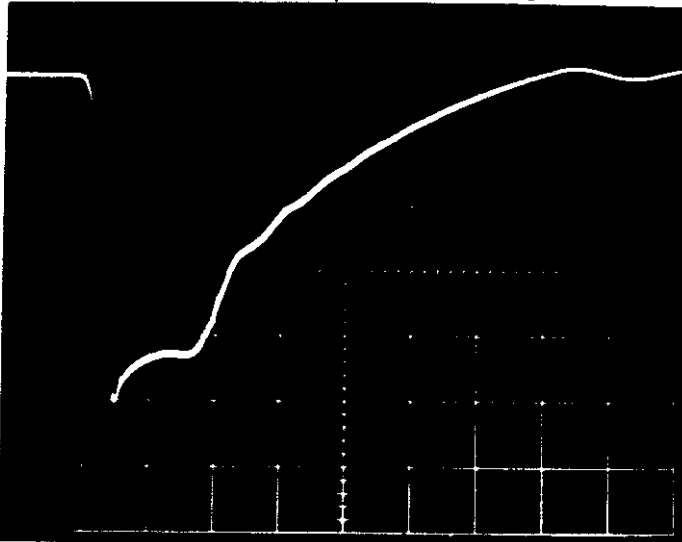

Fig. 4.2.2 Middle Pulse (1.5 nm Range)

Scale: 1 kV/div. 0.2  $\mu$ s/div.

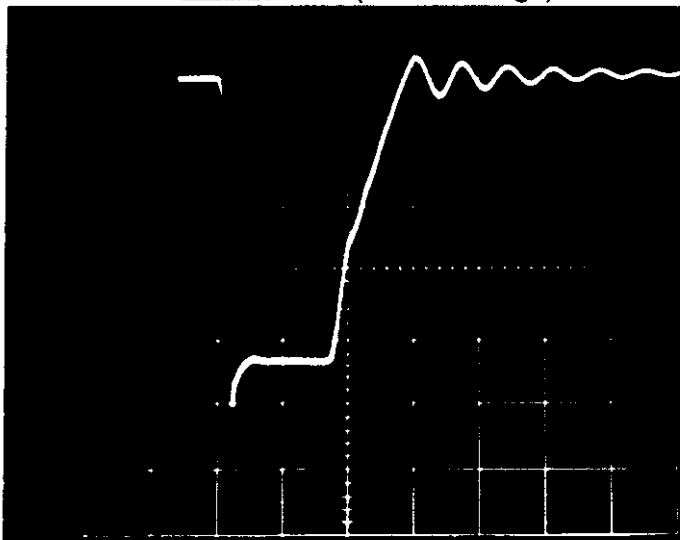

Fig. 4.2.3 Long Pulse (64 nm Range)

Scale: 1 kV/div. 0.5  $\mu$ s/div.



### 4.3 Magnetron Output (detected):

#### 4.3.1 Setup for Measurement:

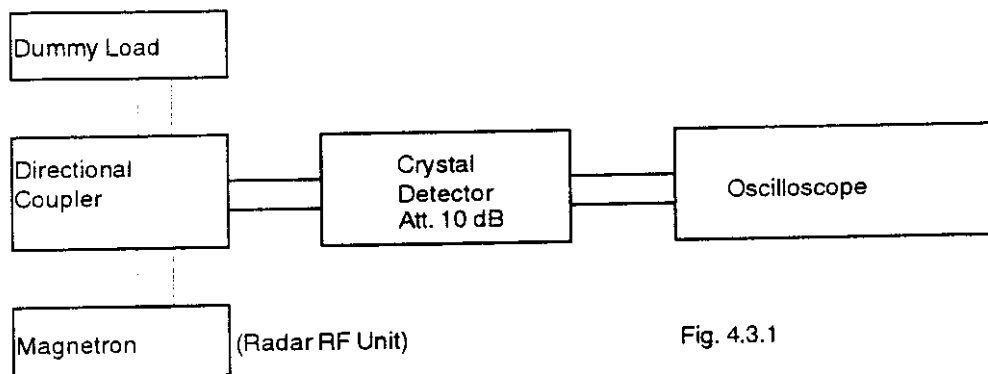

Fig. 4.3.1

#### 4.3.2 Measuring Equipment List:

See ATTACHMENT 4 [ LIST OF TEST/MEASURING EQUIPMENT ].

4.3.3 Measured Data:

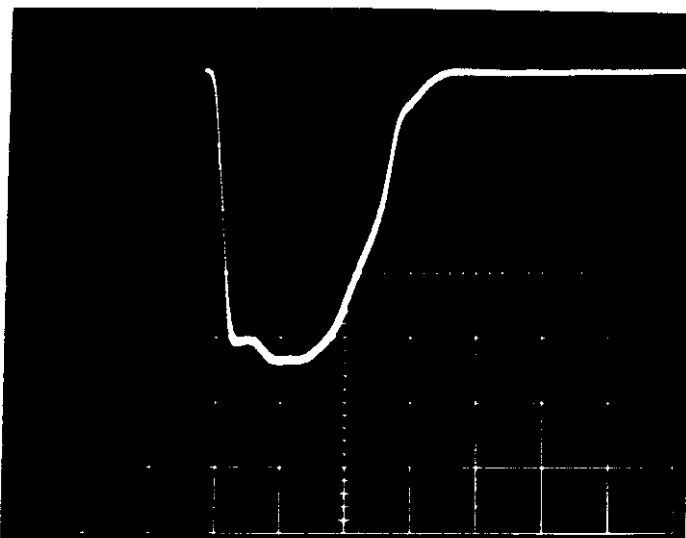

Fig. 4.3.2 Short Pulse (0.25 nm Range)

Scale: 20 mV/div. 0.05  $\mu$ s/div.

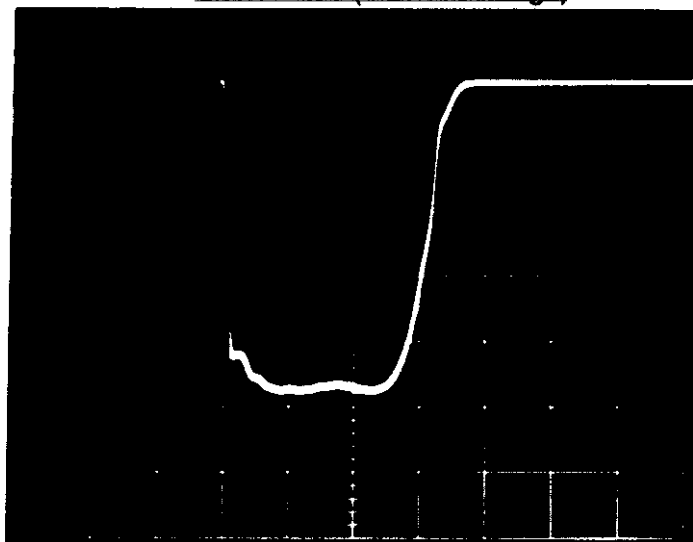

Fig. 4.3.3 Middle Pulse (1.5 nm Range)

Scale: 20 mV/div. 0.1  $\mu$ s/div.

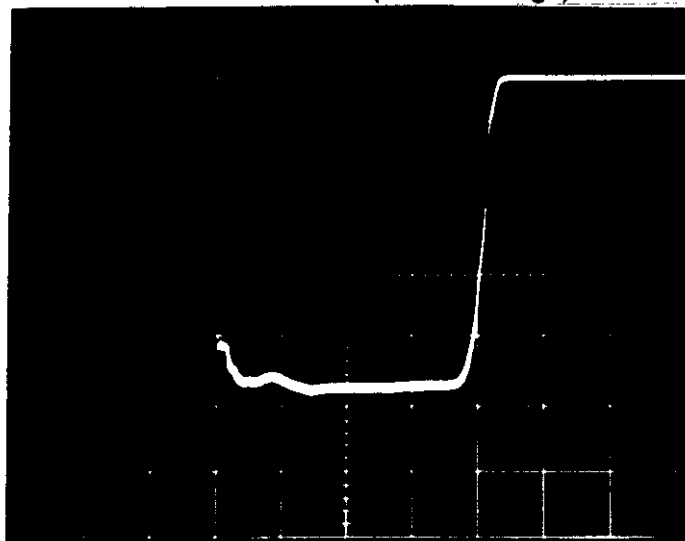

Fig. 4.3.4 Long Pulse (64 nm Range)

Scale: 20 mV/div. 0.2  $\mu$ s/div.

#### 4.4 Radar Pulse Spectrum:

Measured by the spectrum analyzer.

(Test Equipment Setup and Measuring Equipment List are same as Clause 6.1 and 6.2.)

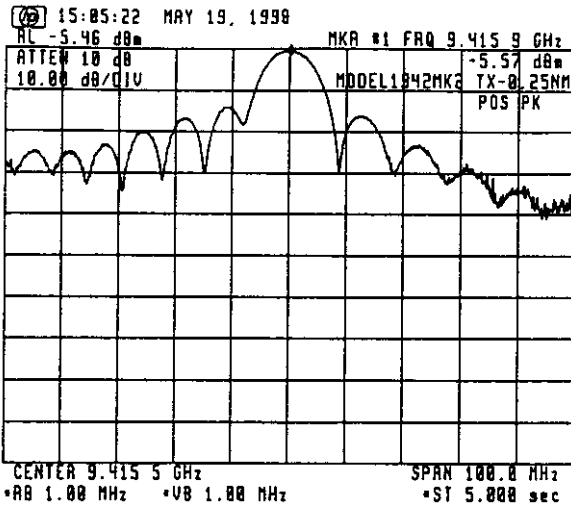

Fig. 4.4.1 Short Pulse (0.25 nm Range)

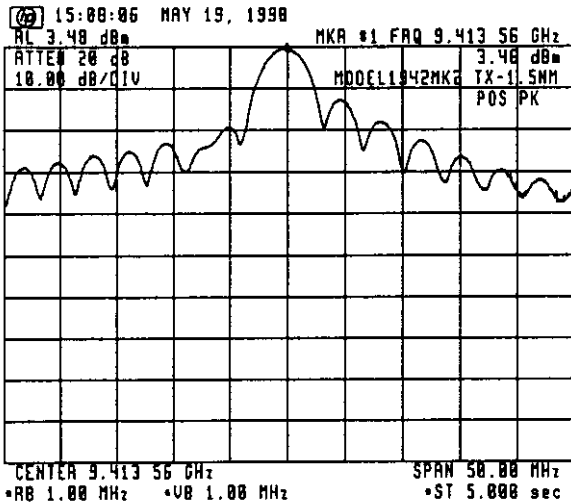

Fig. 4.4.2 Middle Pulse (1.5 nm Range)

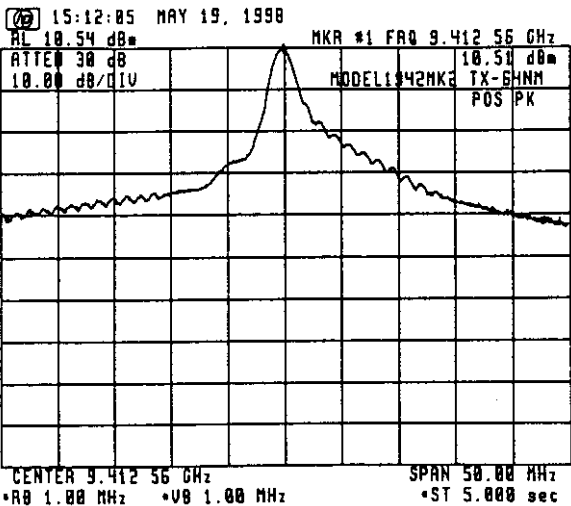

Fig. 4.4.3 Long Pulse (64 nm Range)



## 5 OCCUPIED BANDWIDTH (FCC Rule §2.989)

### 5.1 Measuring Method

FCC rule 47 CFR 2.989 requires measurements of the occupied bandwidth which is defined in the same section as "the frequency bandwidth such that, below its lower and above its upper frequency limits, the mean powers radiated are each equal to 0.5 percent of the total mean power radiated by a given emission."

To obtain the occupied bandwidth of the radar transmitter, a special program (program list shown below) was loaded to the Hewlett-Packard spectrum analyzer and run by entering the HP-provided POWER BANDWIDTH calculation command [PWRBW].

The result was automatically displayed on the screen on the spectrum analyzer as:

POWER\_BW=----- MHz

```

10 ! HP_71000 DOWNLOAD PROGRAM
20 ASSIGN @Sa TO 718
30 CLEAR @Sa
40 CALL Main(@Sa)
50 LOCAL @Sa
60 END
70 !
80 SUB Main(@Sa)
90 Main: !
100 CALL Pwr_bw(@Sa)
110 CALL Limit_line(@Sa)
120 !
130 OUTPUT @Sa:"VARDEF K_ey,0;";
140 !
150 OUTPUT @Sa:"FUNCDEF D_LP,^";
160 OUTPUT @Sa:"MOV K_ey,0;";
170 !
180 Main_menu: !
190 OUTPUT @Sa:"REPEAT;";
200 OUTPUT @Sa:"READMENU K_ey;";
210 ! location: %Top---Bottom-%
220 OUTPUT @Sa:"1,%Limit line %,";
230 OUTPUT @Sa:"2,%Power bw %,";
240 OUTPUT @Sa:"14,% Exit%,";
250 !
260 OUTPUT @Sa:"IF K_ey,EQ,1;THEN;LIMIT_LINE;";
270 OUTPUT @Sa:"ELSIF K_ey,EQ,2;THEN;PWR_BW;";
280 OUTPUT @Sa:"ELSIF K_ey,EQ,14;THEN;ABORT;";
290 OUTPUT @Sa:"ENDIF;";
300 OUTPUT @Sa:"UNTIL K_ey,EQ,14;";
310 OUTPUT @Sa:"IP;TS;";
320 OUTPUT @Sa:"ADORT;";
330 OUTPUT @Sa:""
340 !
350 Define_keydef: !
360 OUTPUT @Sa:"KEYDEF 7,D_LP, %DLP TEST%;";
370 !
380 OUTPUT @Sa:"FUNCDEF D,^";
390 OUTPUT @Sa:"KEYPST;";
400 OUTPUT @Sa:""
410 !
420 SUBEND
430 !
440 SUB Limit_line(@Sa)
450 Limit_line: !
460 OUTPUT @Sa:"CLRDSP;";
470 OUTPUT @Sa:"FUNCDEF LIMIT_LINE,^";
480 OUTPUT @Sa:"PU;PA 0,654;";
490 OUTPUT @Sa:"LINET 1;";
500 OUTPUT @Sa:"PD;PA 100,654;";
510 OUTPUT @Sa:"PU;PA 201,654;";
520 OUTPUT @Sa:"PD;PA 300,654;";
530 OUTPUT @Sa:"PU;PA 105,630;";
540 OUTPUT @Sa:"TEXT @-35dB@";";
550 OUTPUT @Sa:"PU;PA 205,720;";
560 OUTPUT @Sa:"TEXT @-25dB@";";
570 OUTPUT @Sa:"PU;PA 301,743;";
580 OUTPUT @Sa:"LINET 1;";
590 OUTPUT @Sa:"PD;PA 400,743;";
600 OUTPUT @Sa:"PU;PA 601,743;";
610 OUTPUT @Sa:"LINET 1;";
620 OUTPUT @Sa:"PD;PA 700,743;";
630 OUTPUT @Sa:"PU;PA 701,654;";
640 OUTPUT @Sa:"LINET 1;";
650 OUTPUT @Sa:"PD;PA 1000,654;HD;";
660 OUTPUT @Sa:""
670 SUBEND
680 SUB Pwr_bw(@Sa)
690 Pwr_bw: !
700 ! Calculating Power band width
710 OUTPUT @Sa:"VARDEF P_bw,0;";
720 OUTPUT @Sa:"FUNCDEF PWR_BW,^";
730 OUTPUT @Sa:"CLRW TRA;";
740 OUTPUT @Sa:"CLRDSP;";
750 OUTPUT @Sa:"SNGLS;";
760 OUTPUT @Sa:"MXMH TRA;TS;TS;TS;";
770 OUTPUT @Sa:"MOV P_bw,PWRBW TRA,99.0;";
780 OUTPUT @Sa:"DIV P_bw,P_bw,1000000;";
790 OUTPUT @Sa:"PU;PA 10,800;HD;";
800 OUTPUT @Sa:"TEXT @POWER_BW = @;";
810 OUTPUT @Sa:"DSPLY P_bw,8,3;";
820 OUTPUT @Sa:"TEXT @ MHz @;";
830 OUTPUT @Sa:""
840 SUBEND

```

Fig. 5.1

Program for Calculation of Occupied Bandwidth

**5.2 Test Equipment Setup:**

Same as Clause 6.1.

**5.3 Measuring Equipment List:**

Same as Clause 6.2.

**5.4 Test Result:**

The test result is shown below.

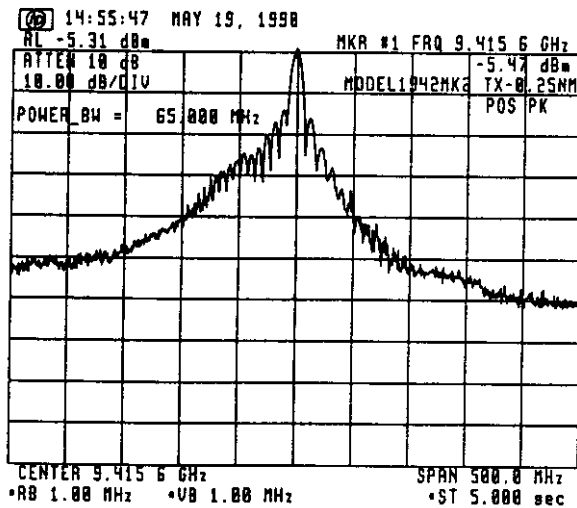

Fig. 5.2 Measurement of Occupied Bandwidth

Occupied bandwidth = 65.000 MHz

## 6 SPURIOUS EMISSIONS AT ANTENNA TERMINAL (FCC Rule §2.991)

### 6.1 Test Equipment Setup:

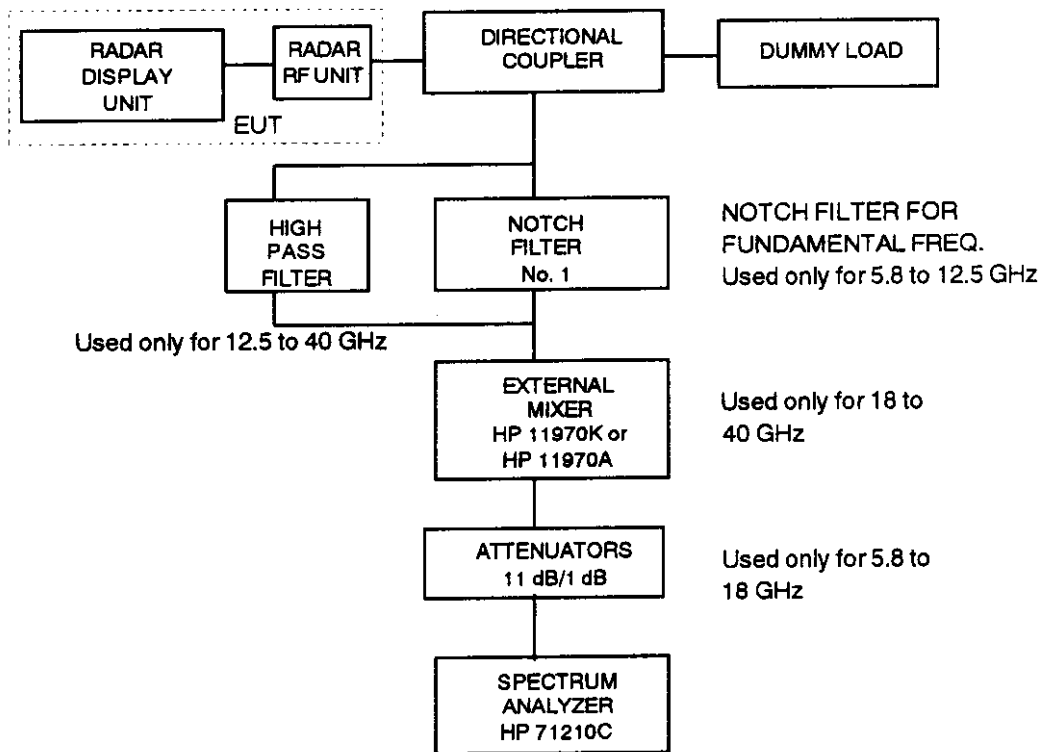

Fig. 6.1

### 6.2 Measuring Equipment List:

See ATTACHMENT 4 [ LIST OF TEST/MEASURING EQUIPMENT ].

Note : (1) The characteristics of Notch Filter (No. 1) are described in Fig. 6.2 to Fig. 6.5.

(2) The characteristic of High Pass Filter (No. 2) is described in Fig. 6.6.

### 6.3 Test Conditions:

Radar Range Settings: 0.25 nm (Short)/1.5 nm (Middle)/64 nm (Long)

**6.4 Emission Limits:**

- (a) Frequency Range (FCC Rule § 2.997) : 10 kHz - 40 GHz
- (b) Emission Limits (FCC Rule § 80.211) :

Frequency removed from the assigned frequency	Frequency (Hz)	Emission attenuation (mean power ,dB)
50 - 100 % (of the authorized bandwidth)	9310 - 9360 M 9460 - 9510 M	At least 25
100 - 250 %	9160 - 9310 M 9510 - 9660 M	At least 35
more than 250 %	10 k - 9160 M 9660 - 40,000 M	At least $43 + 10 \log_{10}$ (mean power in watts)

- Note : (1) Assigned frequency (center frequency) = 9410 MHz  
(2) Authorized bandwidth = 100 MHz

**6.5 Test Results:**

As shown in ATTACHMENT 1 , the spurious emissions at antenna terminal of EUT are found lower than the specified limits.

(Note: Spurious emissions for 10 kHz to 5 GHz are not found due to the antenna terminal structure. (wave guide tube)).



Characteristic of Filter No. 1 (for X-band)

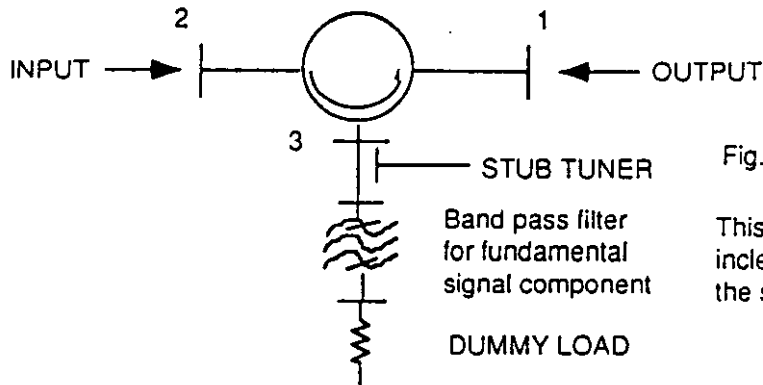

Fig. 6.2 Setup of Notch Filter No.1

This notch filter is used to increase the dynamic range of the spectrum analyzer

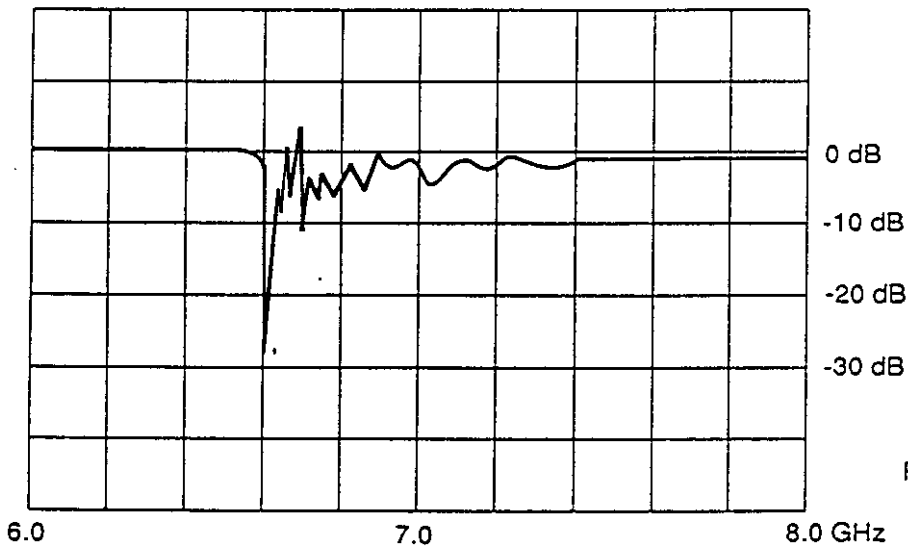

Fig. 6.3

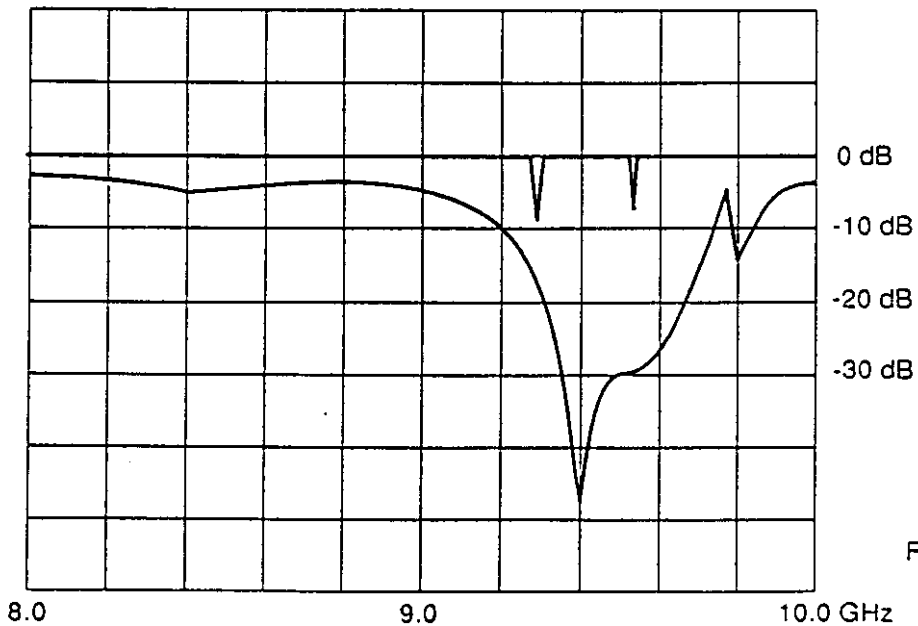

Fig. 6.4

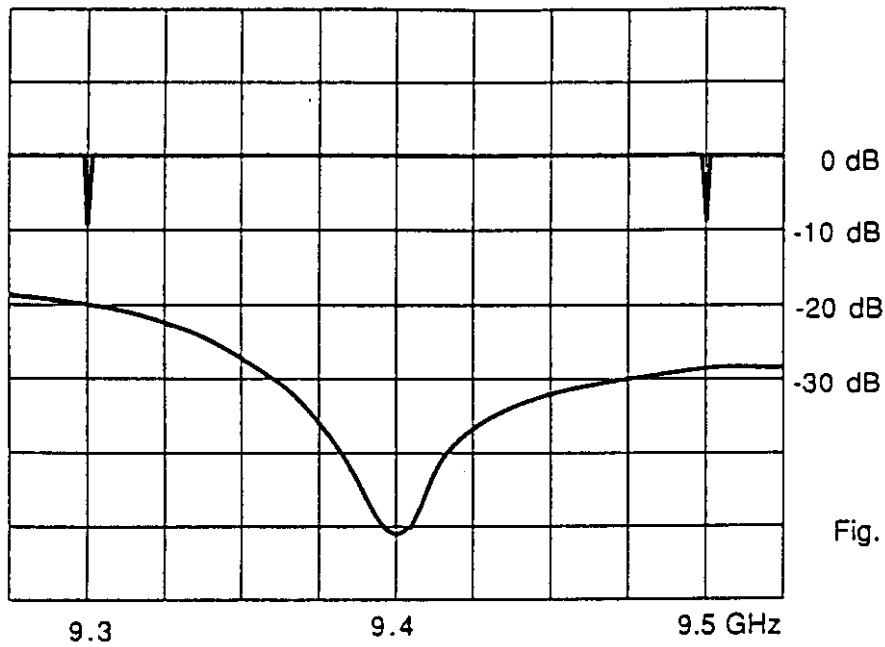
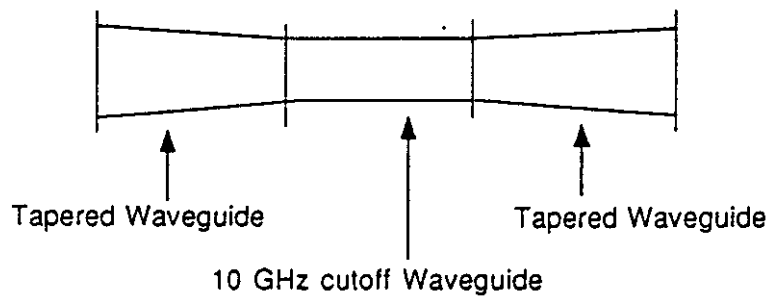

Fig. 6.5

Characteristic of Filter No. 2 (for X-band)



This filter is used to filter out the high level fundamental signal to avoid damage to the analyzer.

High Pass Filter Construction

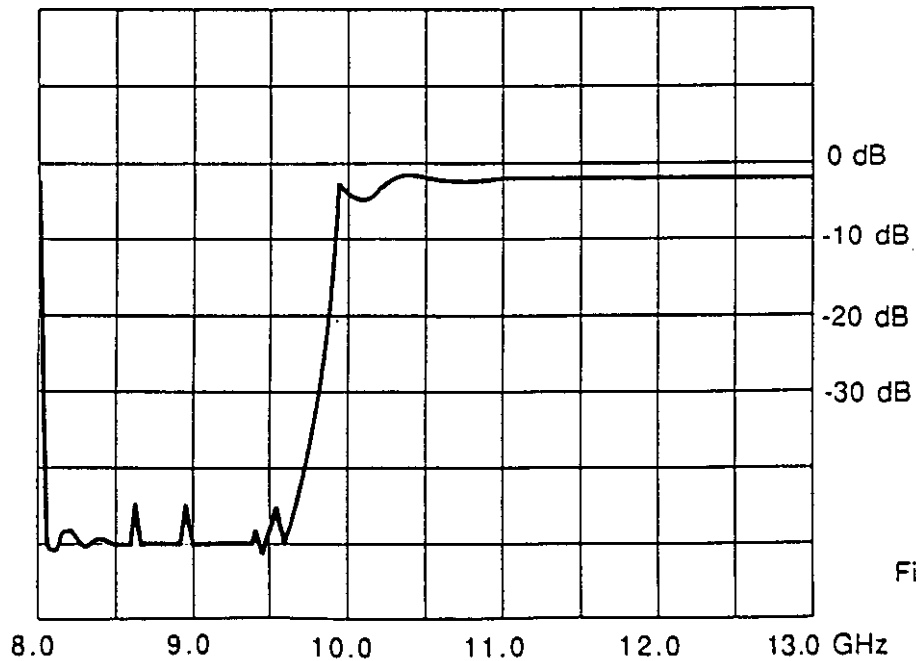

Fig.6.6

**7 FIELD STRENGTH OF SPURIOUS RADIATION (FCC Rule §2.993)**

**7.1 Test Site:** Rooftop of 6-story building,  
 FURUNO ELECTRIC CO., LTD.  
 Ashihara-cho 9-52, Nishinomiya-city, 662-8580 Japan

**7.2 Date:** May, 1998

**7.3 Distance between the radar set and measuring antenna:** 10 m

**7.4 Radar Range settings:** 0.25 nm (Short)/1.5 nm (Middle)/64 nm (Long)

**7.5 Measuring Equipment List:**  
 See ATTACHMENT 4 [ LIST OF TEST/MEASURING EQUIPMENT ].

**7.6 Test settings:**  
 See Fig. 7.1 - Fig. 7.5.

**7.7 Field Strength Limits:**

(a) Frequency Range (FCC Rule §2.997) : 10 kHz - 40 GHz

(b) Emission Limits (FCC Rule §80.211) :

Frequency removed from the assigned frequency	Frequency (Hz)	Emission attenuation (mean power ,dB)
50 - 100 % (of the authorized bandwidth)	9310 - 9360 M 9460 - 9510 M	At least 25
100 - 250 %	9160 - 9310 M 9510 - 9660 M	At least 35
more than 250 %	10 k - 9160 M 9660 - 40,000 M	At least 43 + 10 log 10 (mean power in watts)

Note : (1) Assigned frequency (center frequency) = 9410 MHz

(2) Authorized bandwidth = 100 MHz

**7.8 Test Results:**

As shown in ATTACHMENT 2 , the field strengths of spurious radiation generated by EUT are found lower than the specified limits.

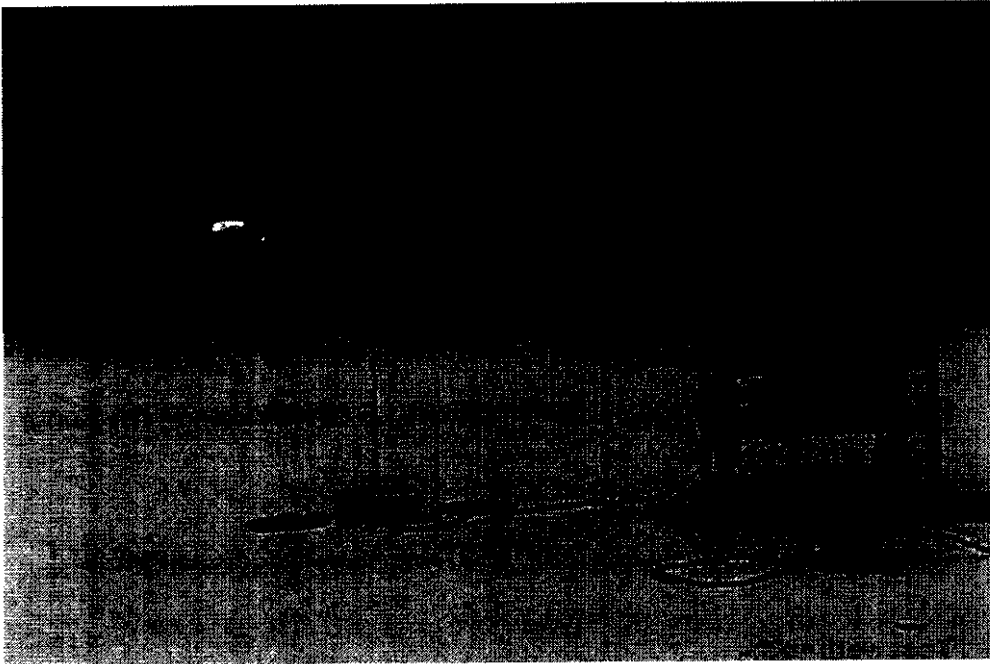

Fig. 7.1      Measuring Antenna:      Broadband Rod Antenna Model 95010-1 of  
Advanced Electronics  
Frequency Range:      10 kHz - 20 MHz

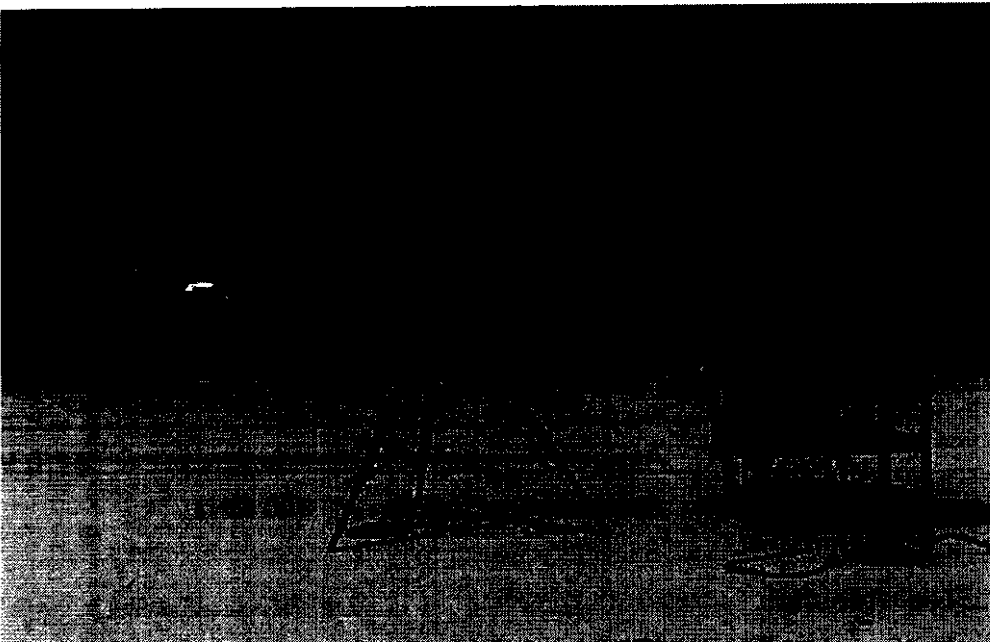

Fig. 7.2      Measuring Antenna:      Biconical Antenna Model BIA-25 of Electro  
Metrics  
Frequency Range:      20 MHz - 200 MHz

## 8 FREQUENCY STABILITY (FCC Rule § 2.995)

### 8.1 Setup for Measurement

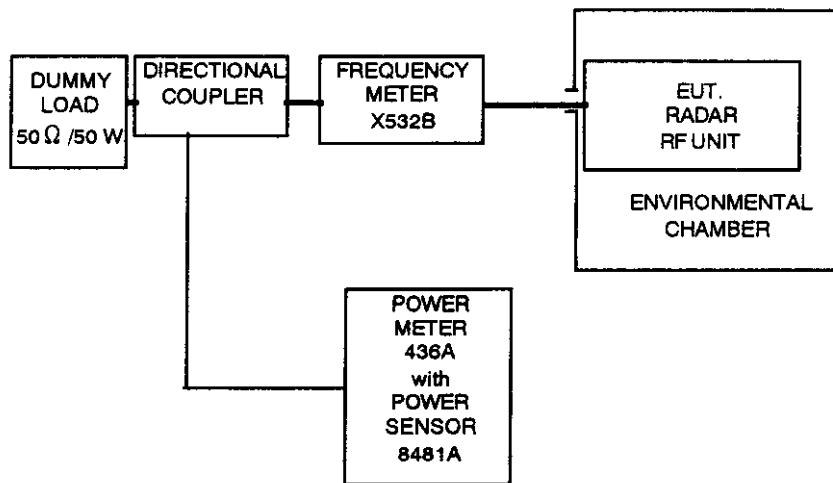

Fig. 8.1

### 8.2 Test Conditions:

- 1) Radar Range settings : 0.25 nm (Short)/1.5 nm (Middle)/64 nm (Long)
- 2) Ambient Temperature settings: - 20 to + 50 °C (10 °C step)
- 3) Power Supply Voltage settings: 85 /115 % of nominal voltage (20.4 to 27.5 VDC)

### 8.3 Measuring Equipment List:

See ATTACHMENT 4 [ LIST OF TEST/MEASURING EQUIPMENT ].

**8.4 Frequency Tolerance Limits:**

"The frequency at which maximum emission occurs must be within the authorized bandwidth and must not be closer than  $1.5/T$  MHz to the upper and lower limits of the authorized band width, where "T" is the pulse duration in microseconds. " (FCC Rule § 80.209)

1) Center frequency ( $f_0$ ): 9410 MHz

2) Authorized bandwidth ( $f(AUBW)$ ): 100 MHz

"Upper limit frequency of the authorized band",  $f(UAUBW) = f_0 + f(AUBW)/2 = 9460$  Mhz

"Lower limit frequency of the authorized band",  $f(LAUBW) = f_0 - f(AUBW)/2 = 9360$  Mhz

3) Assignable frequency bandwidth : 200 MHz (between 9300 MHz and 9500 MHz)

(FCC Rule § 80.375 (d)-(1))

"Upper limit frequency of the assignable band",  $f(UASB) = 9500$  MHz

"Lower limit frequency of the assignable band",  $f(LASB) = 9300$  MHz

4) Guard Band ( $f(1.5/T)$ ) :

Pulse Type	Short	Middle	Long
Range Scale (nm)	0.25	1.5	64
Pulselength ( $\mu$ sec)	0.08	0.30	0.80
Guard Band $f(1.5/T)$ (MHz)	18.75	5.00	1.88

**8.5 Test Results:**

Shown on Fig. 8.2.

(1) "Upper Tolerance Frequency measured (at  $-20$  °C)",  $f(U) = 9417.6$  MHz

(2) "Lower Tolerance Frequency measured (at  $+50$  °C)",  $f(L) = 9409.3$  MHz

(3)-(a)

$f(U) + \max. f(1.5/T) = 9436.4$  MHz  $< f(UAUBW) = 9460$  MHz  $< f(UASB) = 9500$  MHz

(b)

$f(L) - \max. f(1.5/T) = 9390.5$  MHz  $> f(LAUBW) = 9360$  MHz  $> f(LASB) = 9300$  MHz

So, both are found within the specified limits.

FREQUENCY STABILITY WITH VARIATION OF PRIMARY SUPPLY VOLTAGE:

The built-in voltage regulator allows no frequency variation against variations of  $\pm 15\%$  of nominal power supply voltage (20.4 to 27.6 VAC for nominal 24 VDC).

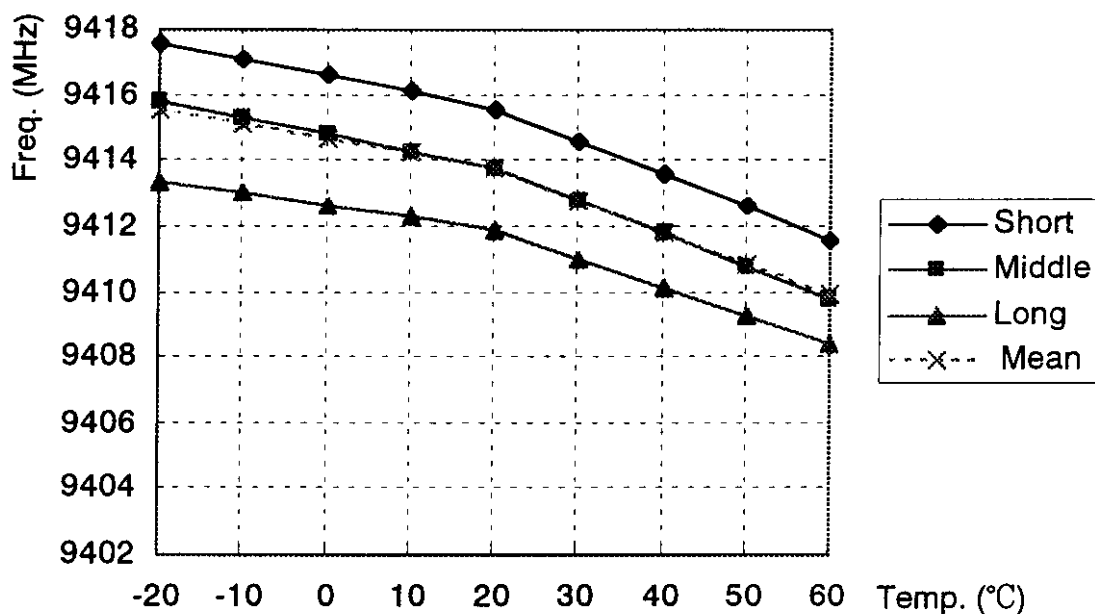

Fig. 8.2 Frequency Stability with Variation of Ambient Temperature

## 9 SUPPRESSION OF INTERFERENCE ABOARD SHIPS

(FCC Rule § 80.217)

### 9.1 Measuring Antenna Characteristics at Representative Frequencies:

Whip antennas are used to determine the level of interference caused by the radar to shipboard receivers. These antennas have the following characteristics (refer to impedance charts attached):

Length	Test Frequency (Hz)	Impedance ( $\Omega$ )	$\theta$	R ( $\Omega$ )	C or L
6 m	500.5 k	1 k	-90°	0	80 pF
6 m	1.992 M	1.25 k	-86°	87.2	64 pF
6 m	10.00204 M	158		109	140 pF
4 m	27.5 M	95		83.5	128 pF
5/8 $\lambda$	150 M	116.5		105.5	52.5 nH
1/4 $\lambda$	450 M	70.5		34.5	5.68 pF

**9.2 Test Site:** Rooftop of 6-story building,  
Furuno Electric Company, Ltd.  
Ashihara-cho 9-52, Nishinomiya-city, 662-8580 JAPAN

### 9.3 Measuring Instruments:

- (1) RF Vector Impedance Meter, HP 4815A
- (2) Spectrum Analyzer, ADVANTEST TR4172
- (3) Spectrum Analyzer, HP 8566B
- (4) Antennas,  
for 14 k - 10 MHz, 6 m whip  
for 10 - 30 MHz, 4 m whip  
for 30 - 300 MHz, VHF whip  
for 300 - 1000 MHz, UHF whip

### 9.4 Test Results:

Interference levels to the respective antenna were measured at 2 m from the radar which was put in OFF, STANDBY, TRANSMIT conditions., and found within the specified limits.



**9.4.1 Harmful Interference to Receiver (FCC Rule § 80.217 (a))**

Limits: for 14 - 490 kHz, 5  $\mu\text{V/m}$   
for 490 kHz - 1 GHz, 1  $\mu\text{V/m}$

Results: There is no spurious component which is deemed harmful interference. (Test data are shown in ATTACHMENT 3 )

**9.4.2 Electromagnetic Field (FCC Rule § 80.217 (b) - 1)**

Limits: for below 30 MHz, 0.1  $\mu\text{V/m}$  at 1 nm (-20 dBmV/m)  
for 30 to 100 MHz, 0.3  $\mu\text{V/m}$  at 1 nm (-10.5 dBmV/m)  
for 100 to 300 MHz, 1.0  $\mu\text{V/m}$  at 1 nm (0 dBmV/m)  
for over 300 MHz, 3.0  $\mu\text{V/m}$  at 1 nm (9.5 dBmV/m)

Results: Interference was measured with the antenna located 2 m from the radar and converted to levels at 1 nm. There is no spurious component exceeding the limits.  
(Test data are shown in ATTACHMENT 3 )

**9.4.3 Power Input to an Artificial Antenna (FCC Rule § 80.217 (b) - 2)**

Limits: for below 30 MHz, 400  $\mu\text{W}$   
for 30 to 100 MHz, 4,000  $\mu\text{W}$   
for 100 to 300 MHz, 40,000  $\mu\text{W}$   
for over 300 MHz, 400,000  $\mu\text{W}$

Results: There is no spurious component exceeding the limits.  
(Test data are shown in ATTACHMENT 3 )



**MEASUREMENT OF IMPEDANCE OF TEST ANTENNAS**

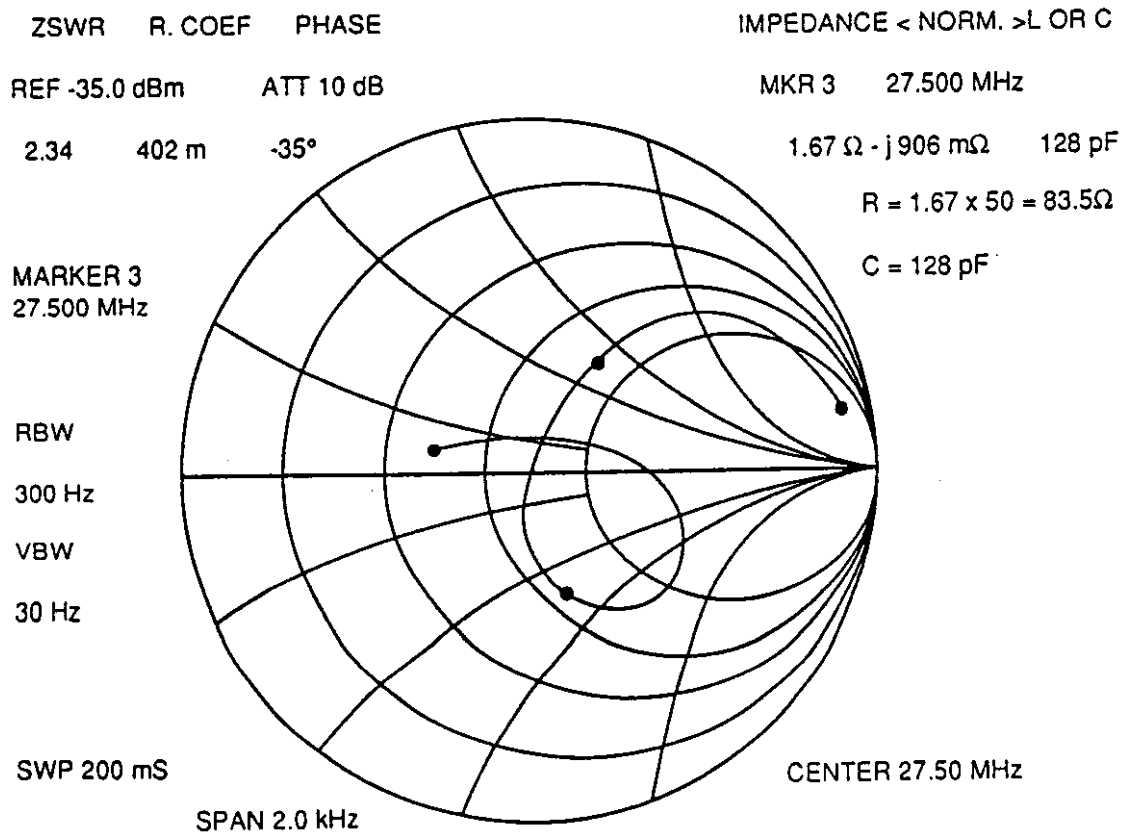
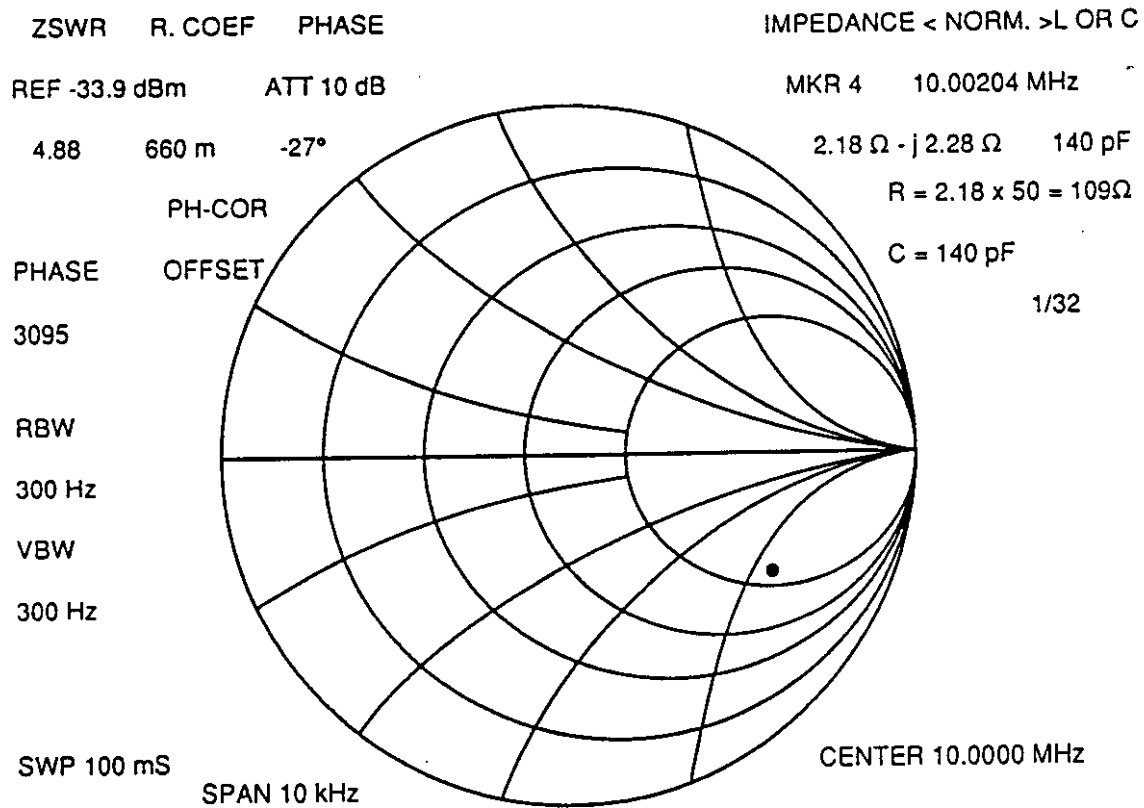

**MEASUREMENT OF IMPEDANCE OF TEST ANTENNAS**

ZSWR	R. COEF	PHASE	IMPEDANCE < NORM. >L OR C
REF -33.7 dBm	ATT 10 dB		MKR 7 150.00 MHz

2.69 458 m -24°

2.11 Ω - j990 Ω 52.5 nH

R = 2.11 x 50 = 105.5 Ω

C = 52.5 nH

MG-COR PH-COR

MARKER 7

150.00 MHz

RBW

100 Hz

VBW

30 Hz

SWP 500 mS

SPAN 10 kHz

CENTER 150.0 MHz

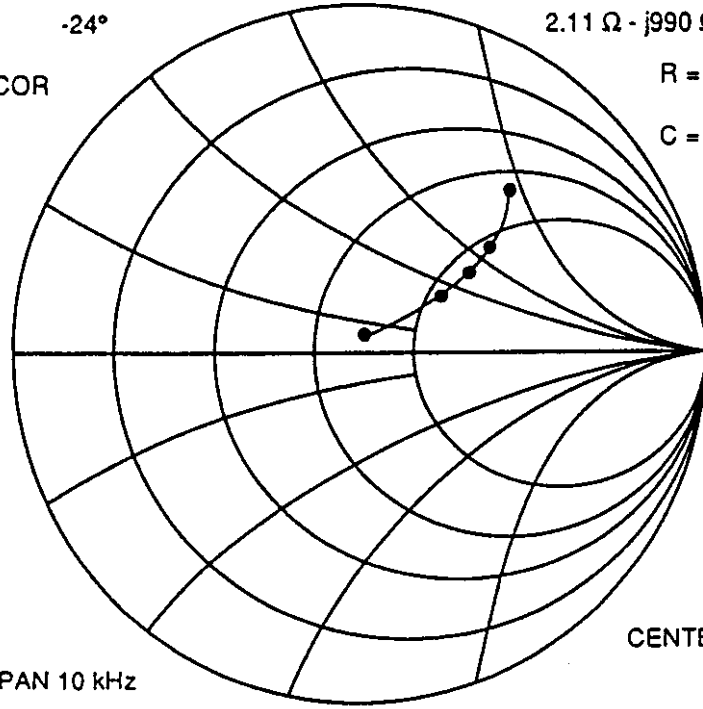

ZSWR	R. COEF	PHASE	IMPEDANCE < NORM. >L OR C
REF -35.1 dBm	ATT 10 dB		MKR 1 450.00 MHz

4.16 612 m -68°

689 Ω - j 1.23 mΩ 5.68 pF

R = 0.689 x 50 = 34.5 Ω

C = 5.68 pF

MARKER 1  
450.00 MHz

RBW

100 Hz

VBW

30 Hz

SWP 500 mS

SPAN 10 kHz

CENTER 450.0 MHz

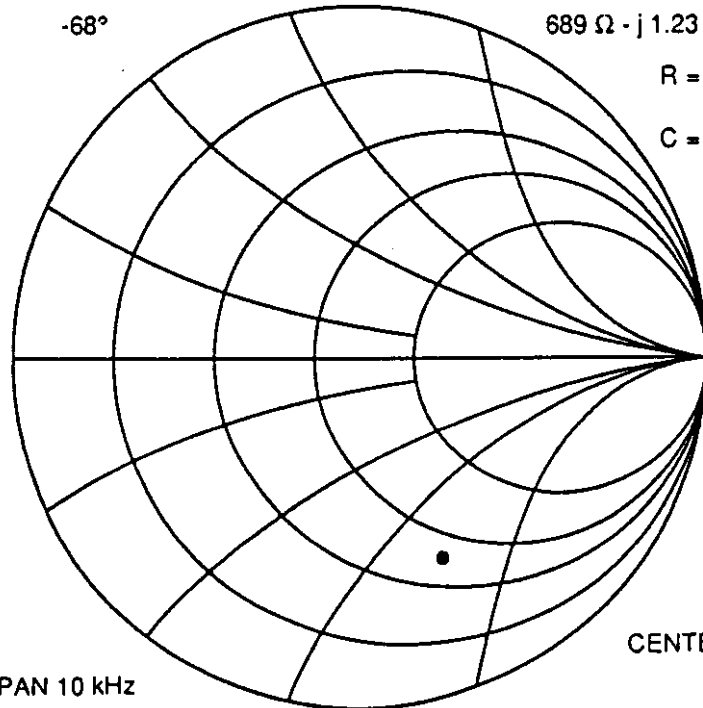

Pub. No. : TI-1696

Date : July, 1998

**12 OPERATOR'S MANUAL INCL. CIRCUIT DIAGRAMS (FCC Rule § 2.983)**

(See separate covers)



ATTACHMENT 1

[ TEST DATA FOR 6. SPURIOUS EMISSIONS AT ANTENNA TERMINALS ]

1. Spurious emissions for 0.25 nm Range:

Ref. level: -5.2 dBm

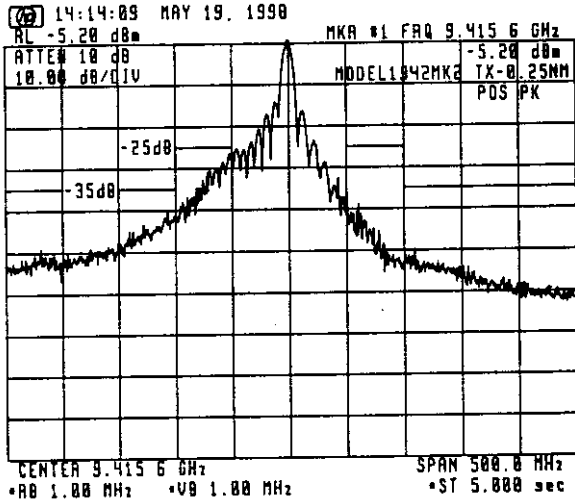

Emission limitations:

- (a) 25 dB for 50 to 100 % of the authorized BW (100 MHz)
- (b) 35 dB for 100 to 250 % of the authorized BW (100 MHz)

Fig. 1.1 Without Filter

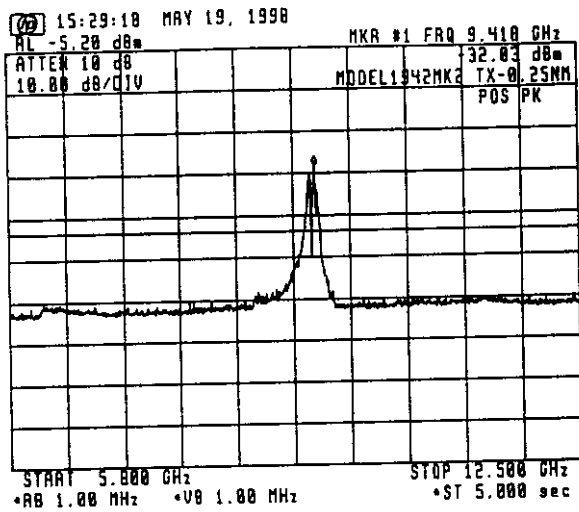

Emission limitations:

- (c)  $43 + 10 \log P_m = 43.34 \text{ dB}$  for more than 250 % of the authorized BW (100 MHz)

Fig. 1.2 With Filter No.1

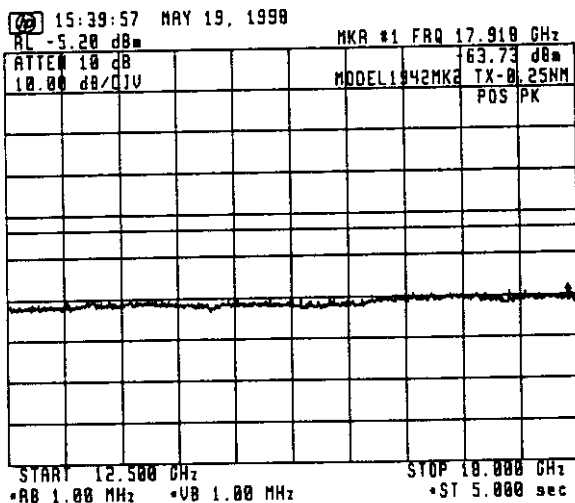

Emission limitations:

- (c)  $43 + 10 \log P_m = 43.34 \text{ dB}$  for more than 250 % of the authorized BW (100 MHz)

Fig. 1.3 With Filter No. 2

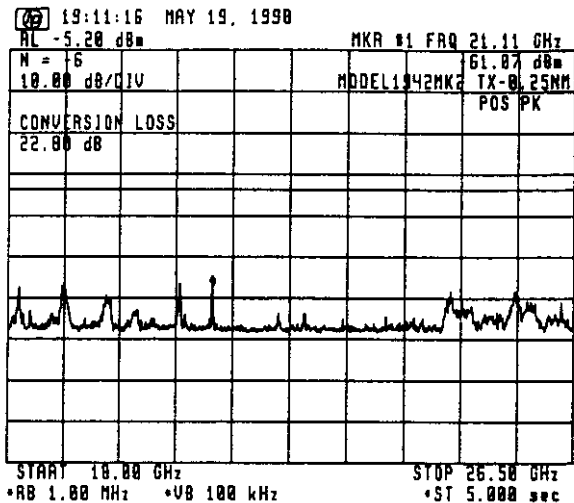

Emission limitations:

(c)  $43 + 10 \log P_m = 43.34 \text{ dB}$   
 for more than 250 % of  
 the authorized BW (100 MHz)

Fig. 1.4 With Filter No. 2

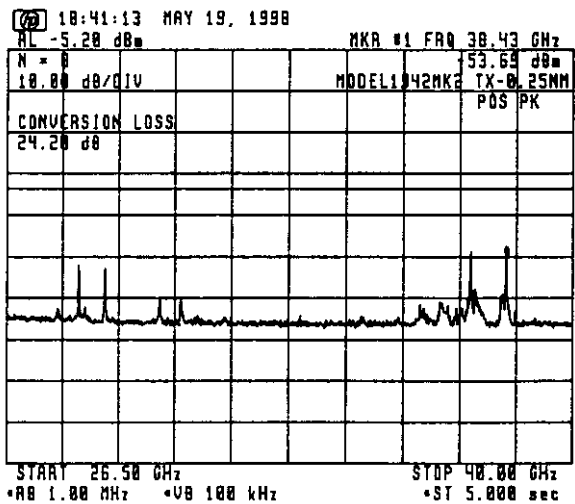

Emission limitations:

(c)  $43 + 10 \log P_m = 43.34 \text{ dB}$   
 for more than 250 % of  
 the authorized BW (100 MHz)

Fig. 1.5 With Filter No. 2



2. Spurious emissions for 1.5 nm Range:

Ref. level: 3.42 dBm

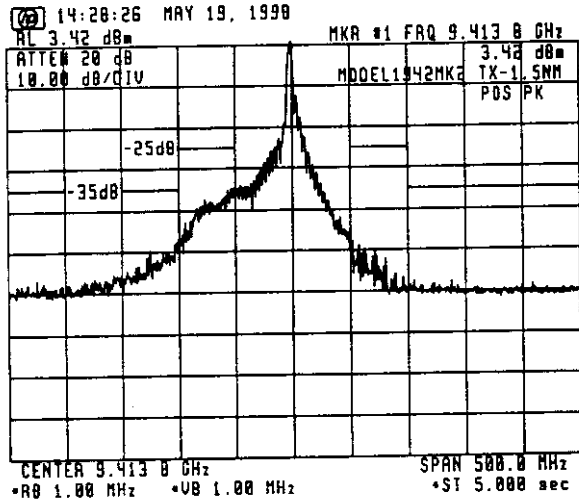

Emission limitations:

- (a) 25 dB for 50 to 100 % of the authorized BW (100 MHz)
- (b) 35 dB for 100 to 250 % of the authorized BW (100 MHz)

Fig. 2.1 Without Filter

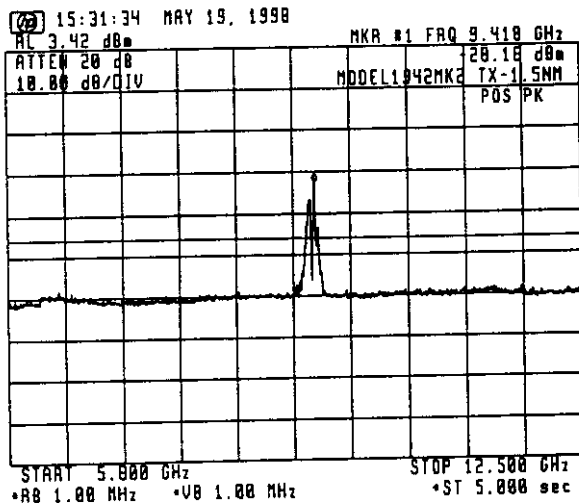

Emission limitations:

- (c)  $43 + 10 \log P_m = 45.74 \text{ dB}$  for more than 250 % of the authorized BW (100 MHz)

Fig. 2.2 With Filter No.1

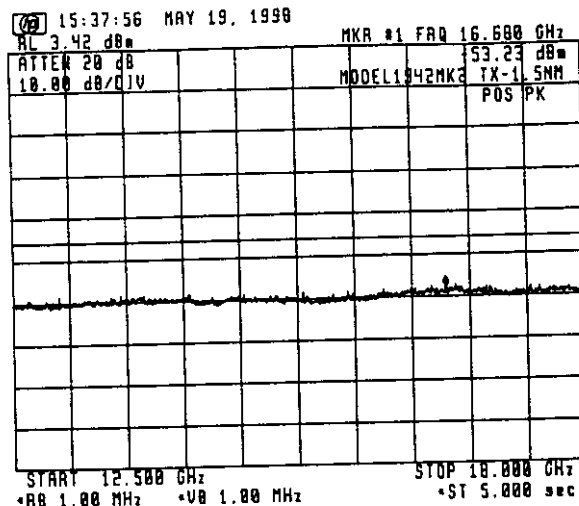

Emission limitations:

- (c)  $43 + 10 \log P_m = 45.74 \text{ dB}$  for more than 250 % of the authorized BW (100 MHz)

Fig. 2.3 With Filter No. 2

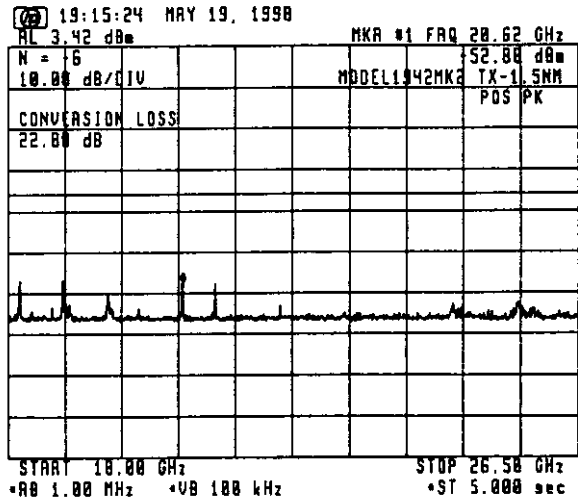

Emission limitations:

(c)  $43 + 10 \log P_m = 45.74 \text{ dB}$   
 for more than 250 % of  
 the authorized BW (100 MHz)

Fig. 2.4 With Filter No. 2

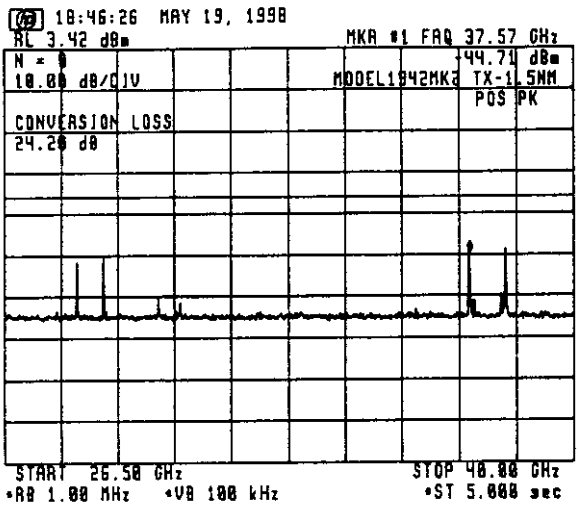

Emission limitations:

(c)  $43 + 10 \log P_m = 45.74 \text{ dB}$   
 for more than 250 % of  
 the authorized BW (100 MHz)

Fig. 2.5 With Filter No. 2

3. Spurious emissions for 64 nm Range:

Ref. level: 10.53 dBm

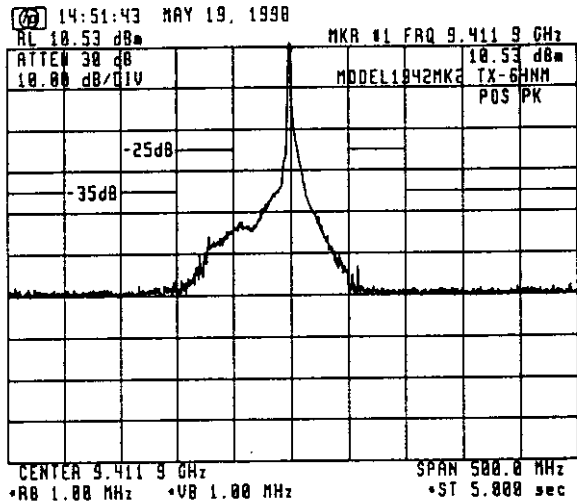

Emission limitations:

- (a) 25 dB for 50 to 100 % of the authorized BW (100 MHz)
- (b) 35 dB for 100 to 250 % of the authorized BW (100 MHz)

Fig. 3.1 Without Filter

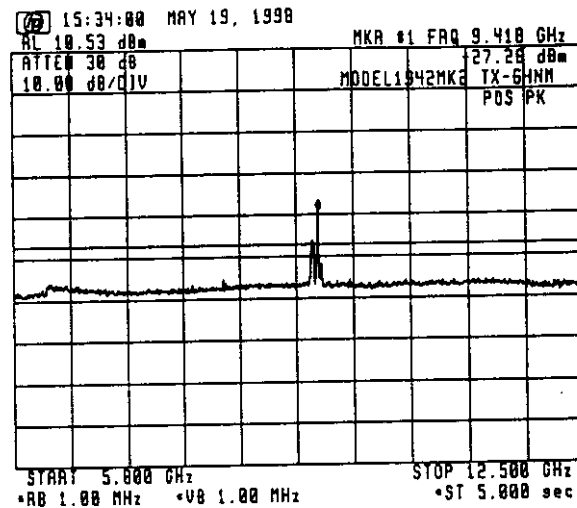

Emission limitations:

- (c)  $43 + 10 \log P_m = 46.89 \text{ dB}$  for more than 250 % of the authorized BW (100 MHz)

Fig. 3.2 With Filter No.1

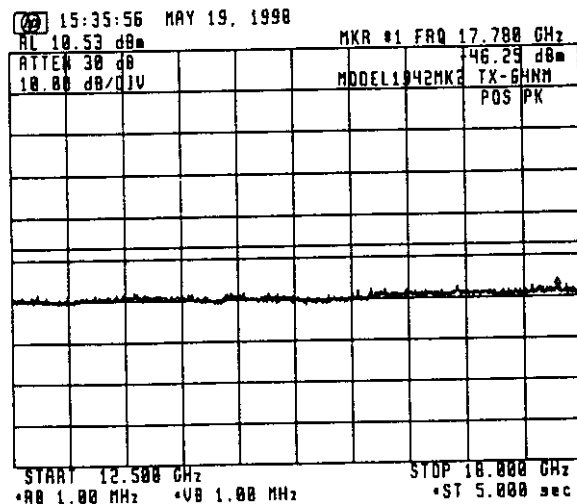

Emission limitations:

- (c)  $43 + 10 \log P_m = 46.89 \text{ dB}$  for more than 250 % of the authorized BW (100 MHz)

Fig. 3.3 With Filter No. 2

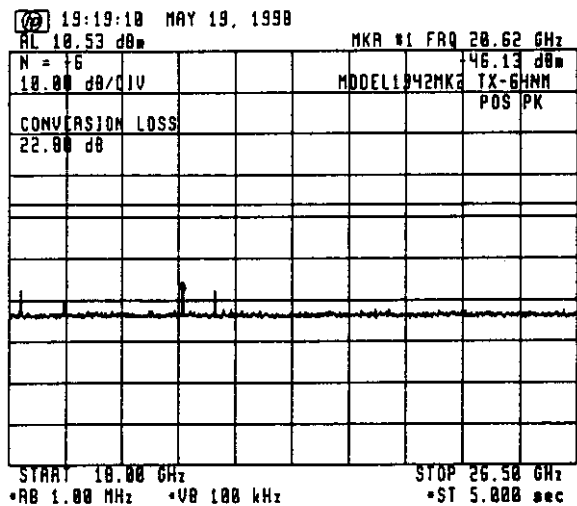

Emission limitations:

(c)  $43 + 10 \log P_m = 46.89 \text{ dB}$   
 for more than 250 % of  
 the authorized BW (100 MHz)

Fig. 3.4 With Filter No. 2

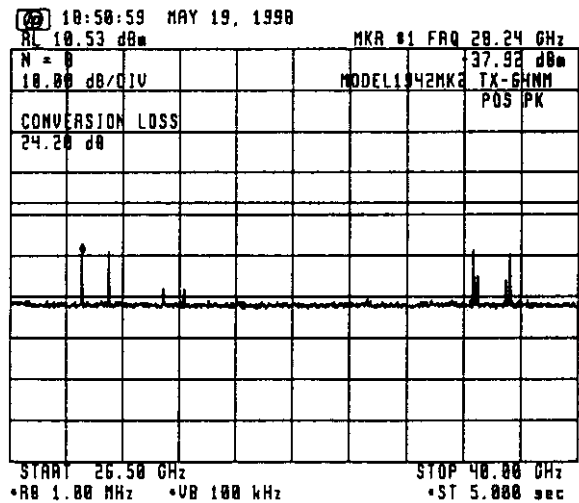

Emission limitations:

(c)  $43 + 10 \log P_m = 46.89 \text{ dB}$   
 for more than 250 % of  
 the authorized BW (100 MHz)

Fig. 3.5 With Filter No. 2

ATTACHMENT 2

[ TEST DATA FOR 7. FIELD STRENGTH OF SPURIOUS RADIATION ]

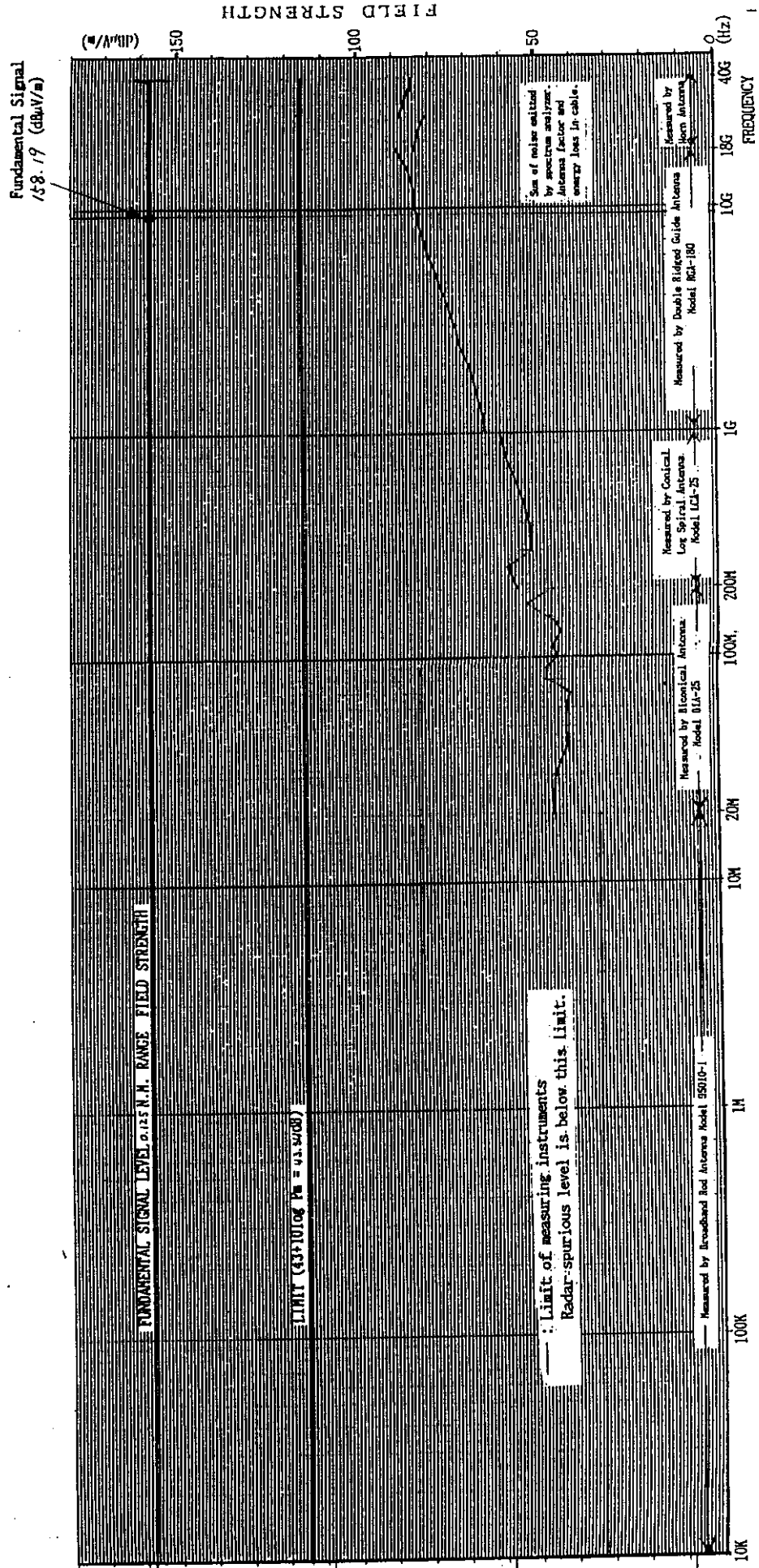

Graph - Field strength of spurious radiation measured with pick-up antenna ( 0.1-2.5 nm range ) ( short Pulse )

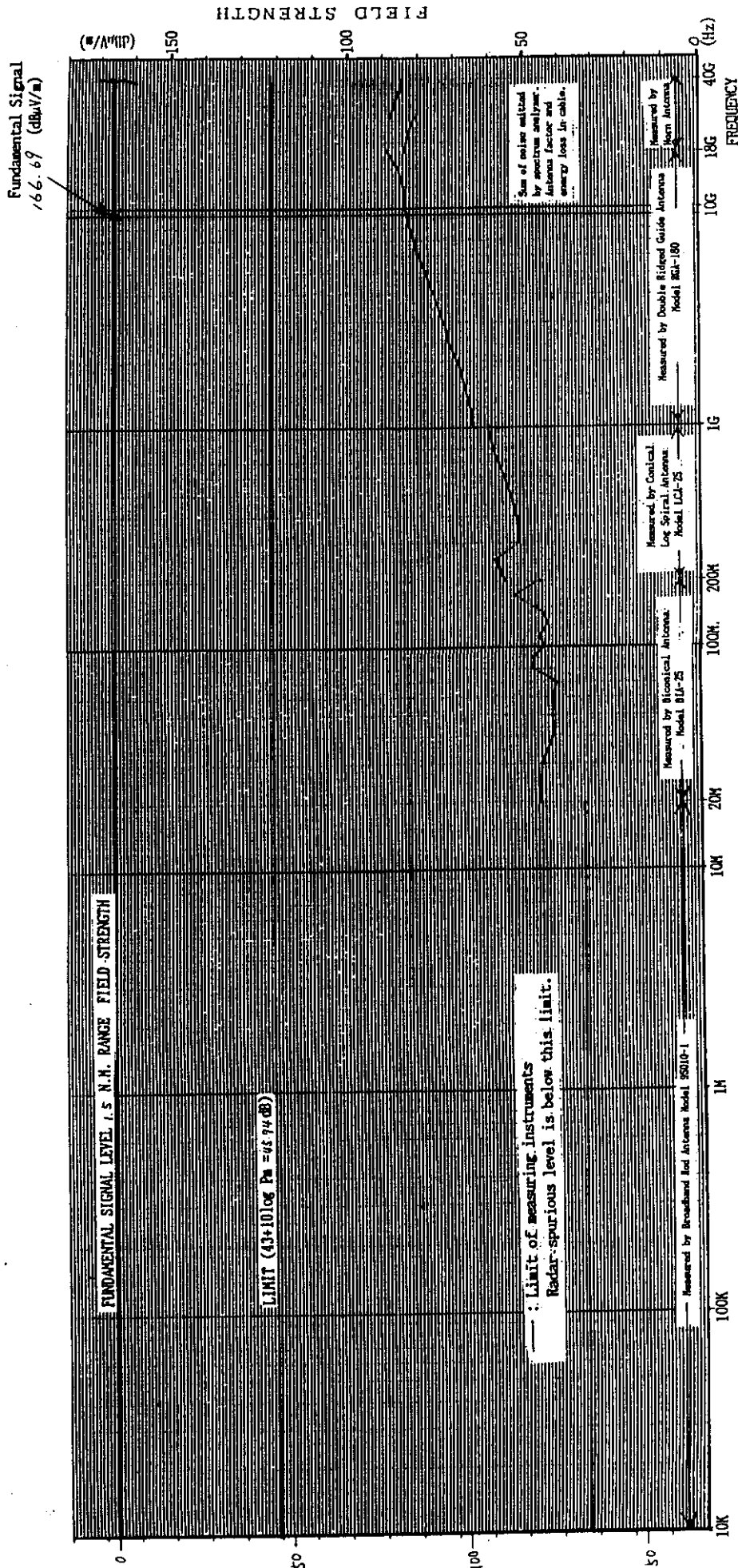

Graph - Field strength of spurious radiation measured with pick-up antenna ( 1.5 n.m range )  
 (middle Pulse)

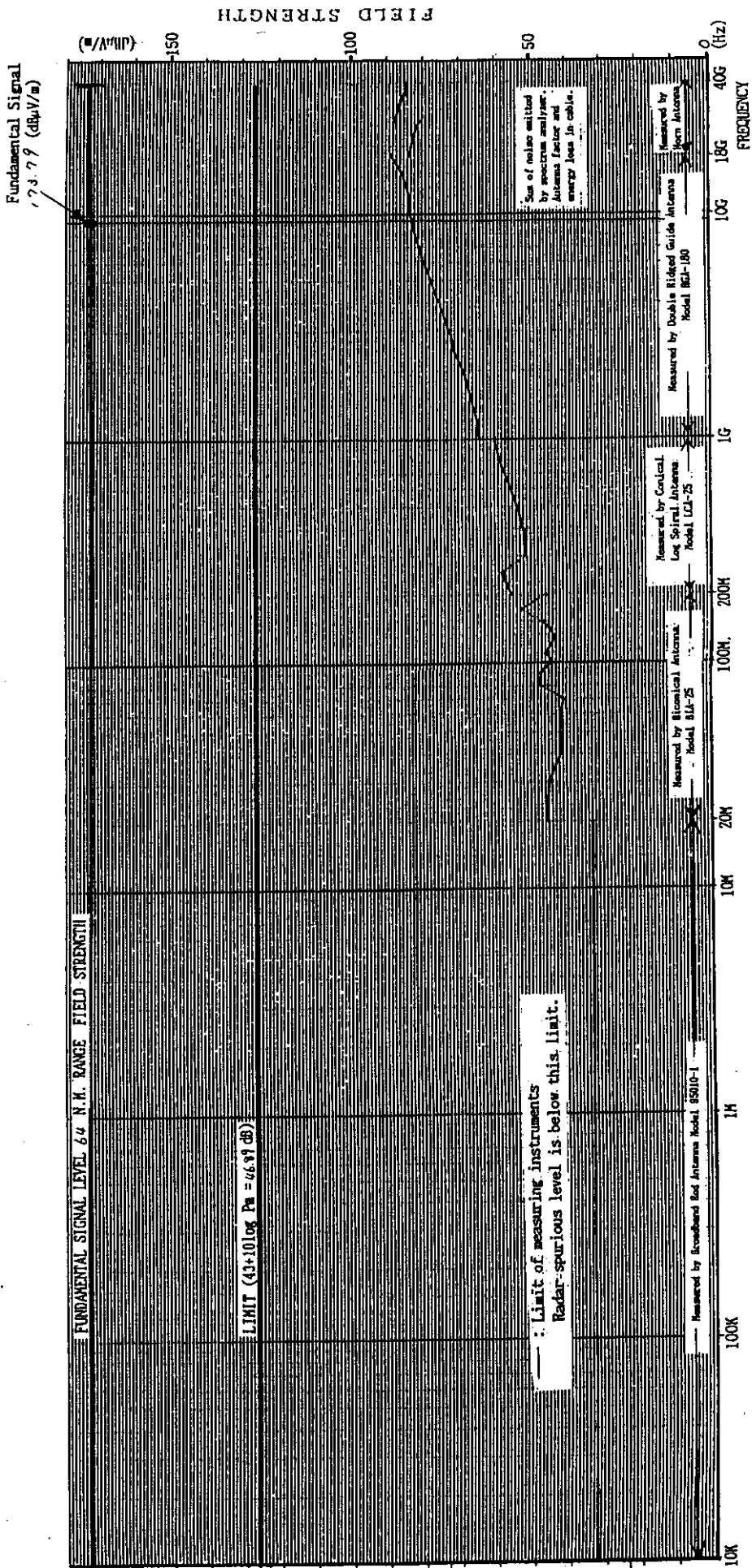

Graph - Field strength of spurious radiation measured with pick-up antenna ( 64 nm range )  
( long Pulse )





### ATTACHMENT 3

## [ TEST DATA FOR 9. SUPPRESSION OF INTERFERENCE ABOARD SHIPS ]

### 1. Harmful Interference to Receiver

Band: 14kHz ~ 490kHz

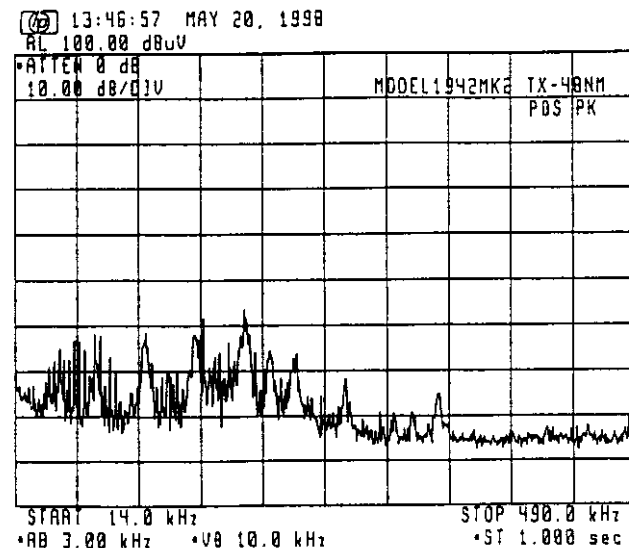
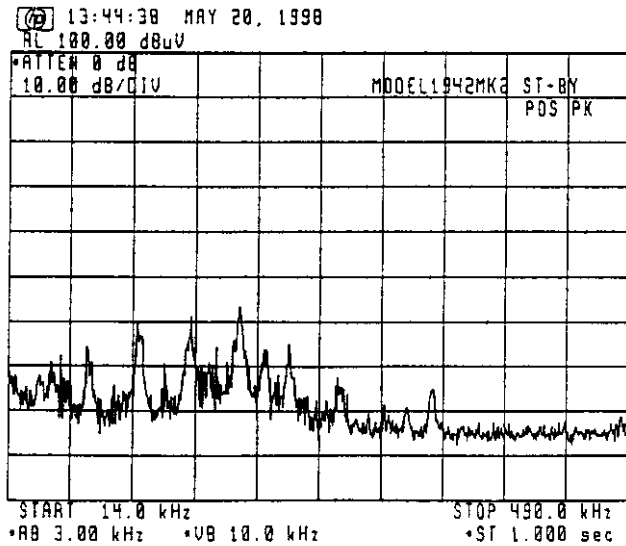
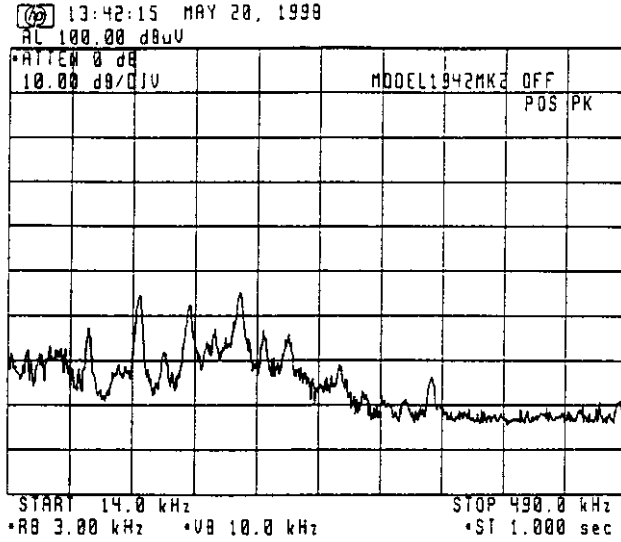

Band: 490kHz ~ 5MHz

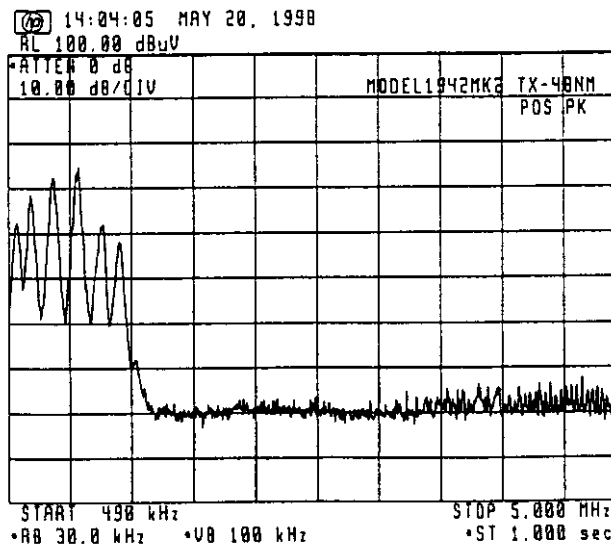
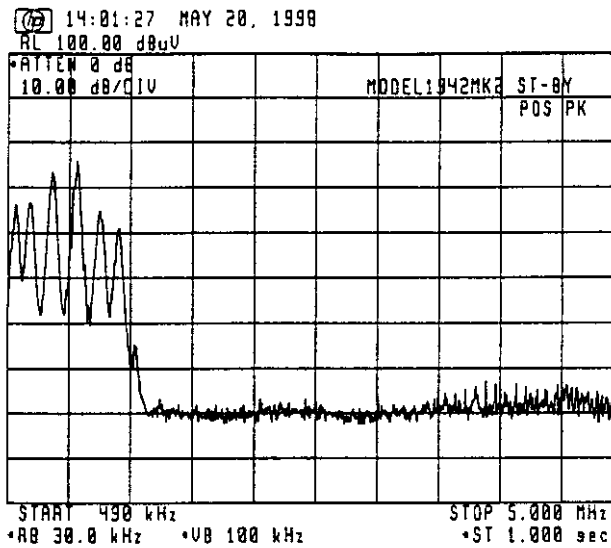
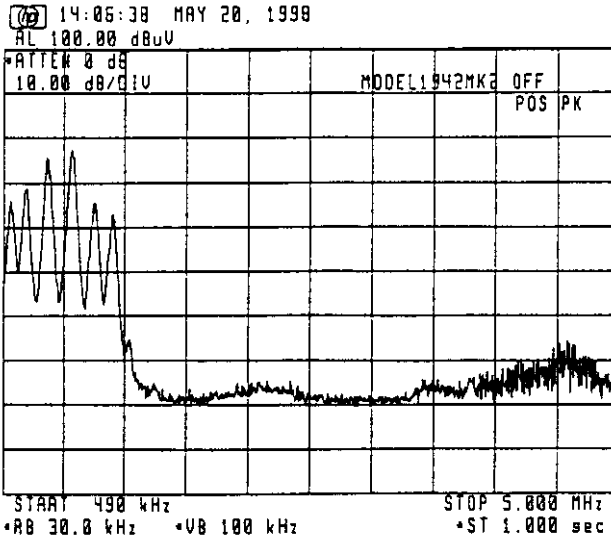

Band: 5MHz ~ 10MHz

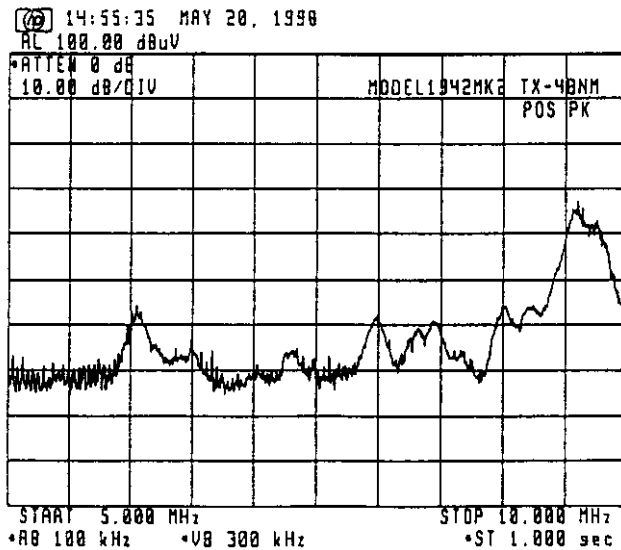
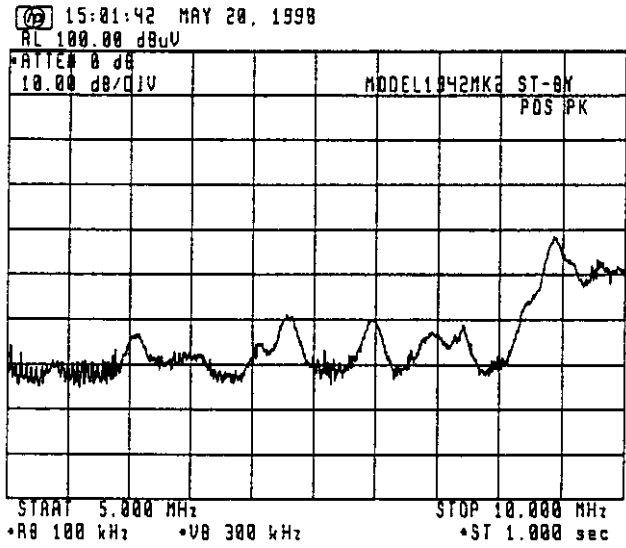
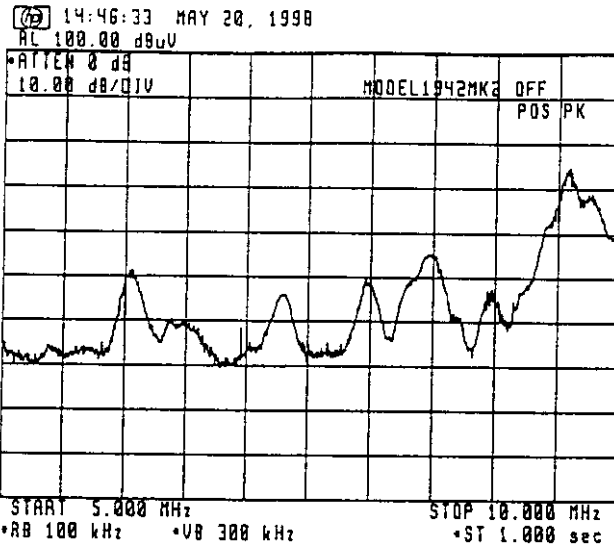

Band: 10MHz ~ 30MHz

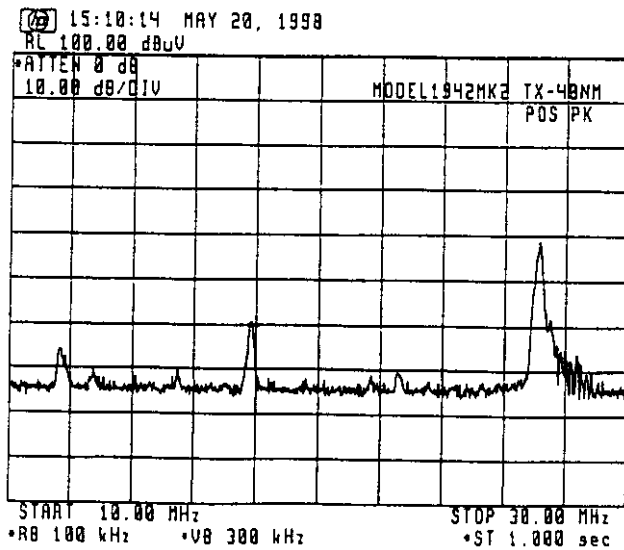
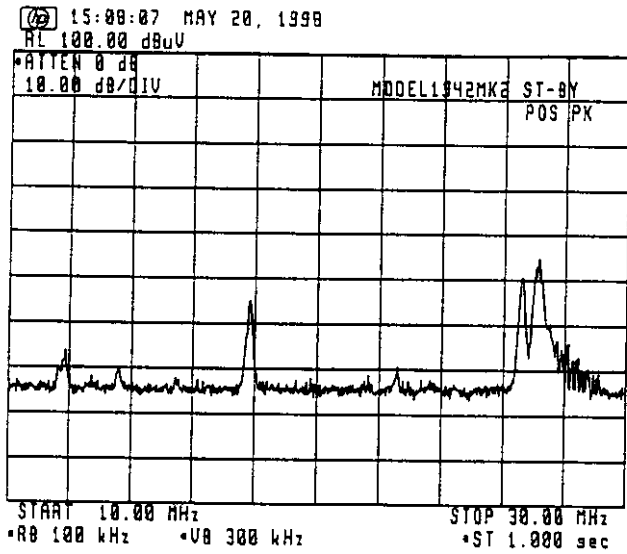
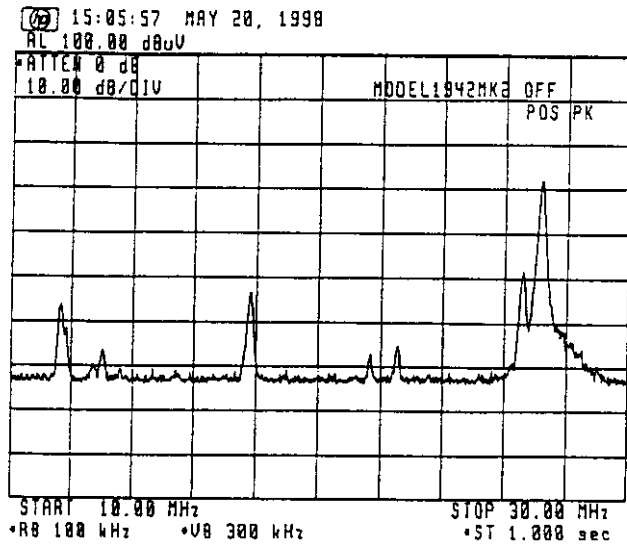

Band: 30MHz ~ 100MHz

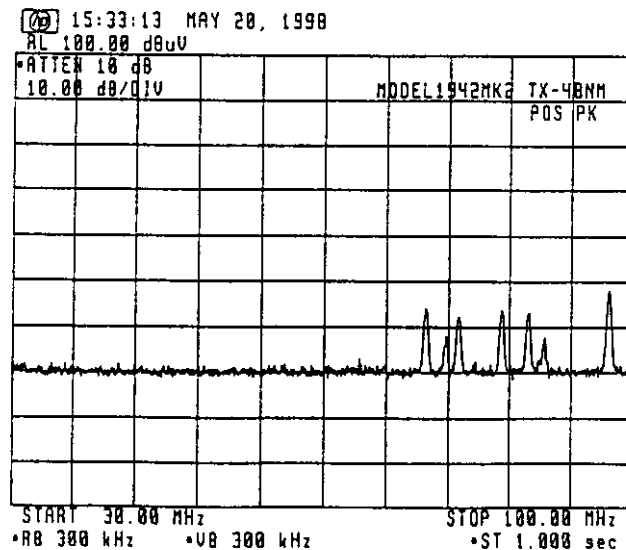
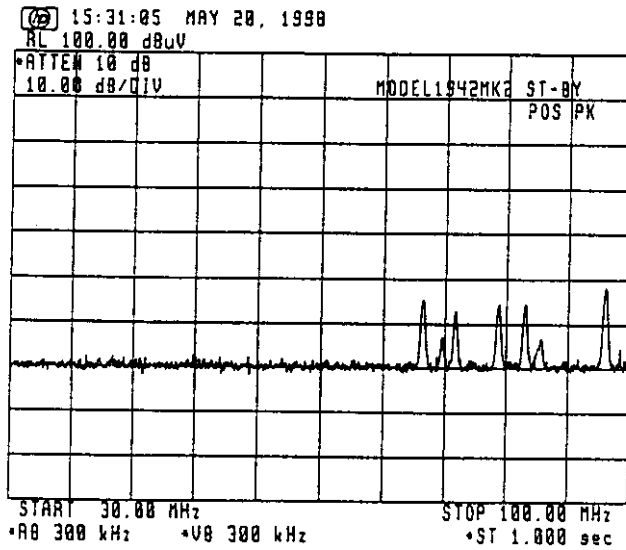
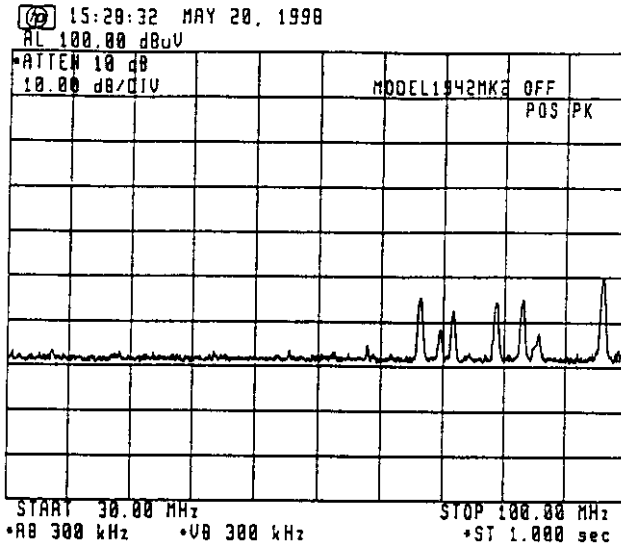

Band : 100MHz ~ 300MHz

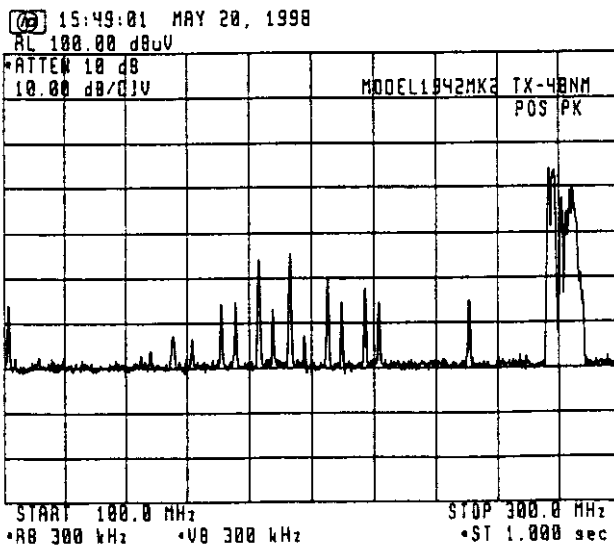
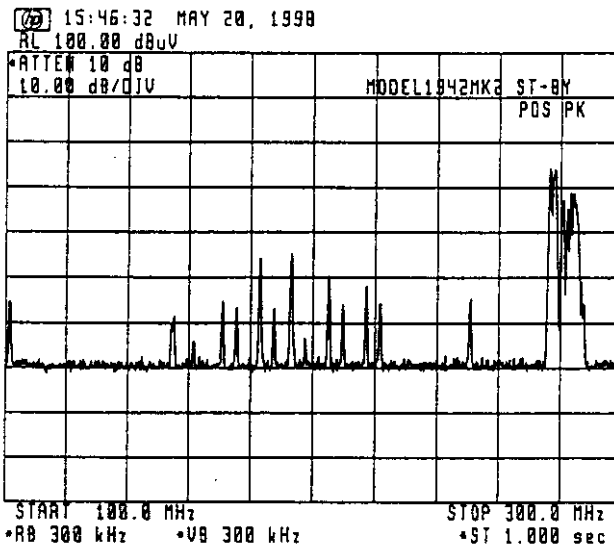
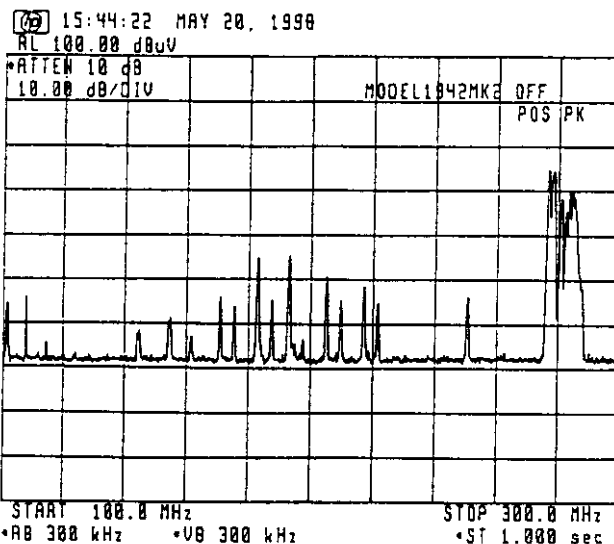

Band: 300MHz ~ 1GHz

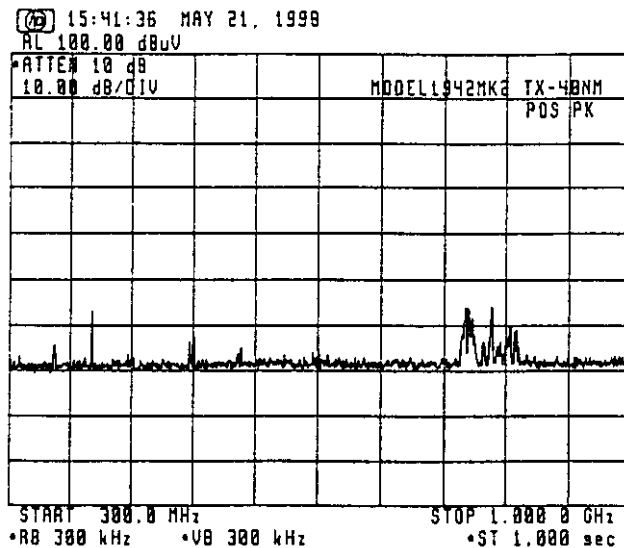
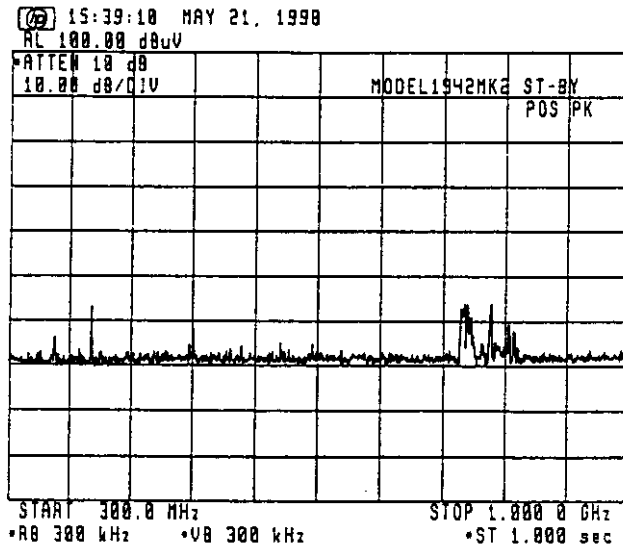
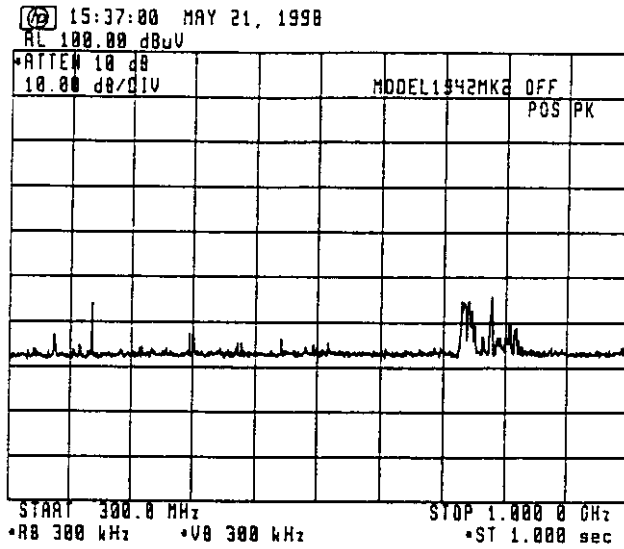

2. Electromagnetic Field

Band: 14kHz ~ 490kHz (Limit at 1 N.M. =  $0.1 \mu\text{V}/\text{m} = -20 \text{dB}\mu\text{V}/\text{m}$ )

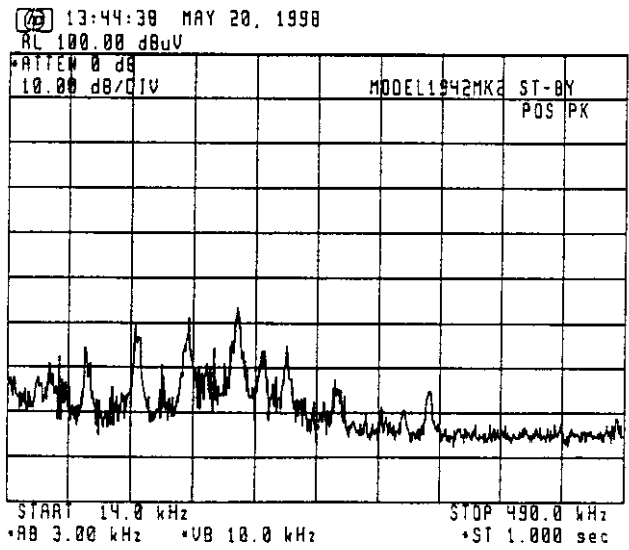
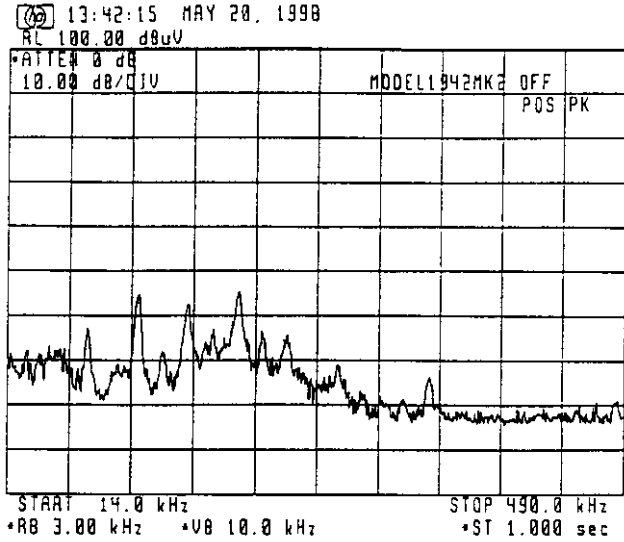

REF.  
→ 6 dB $\mu\text{V}/\text{m}$

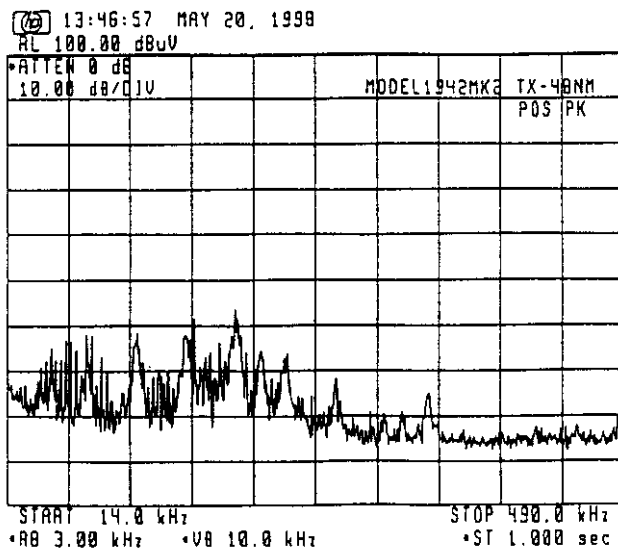

REF.  
→ 6 dB $\mu\text{V}/\text{m}$



Band = 490 kHz ~ 5 MHz (Limit at 1 N.M = 0.1  $\mu$ V/m = -20 dB $\mu$ V/m)

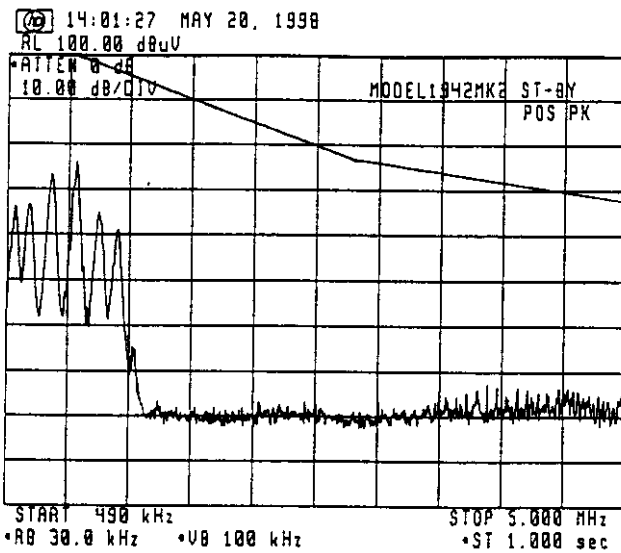
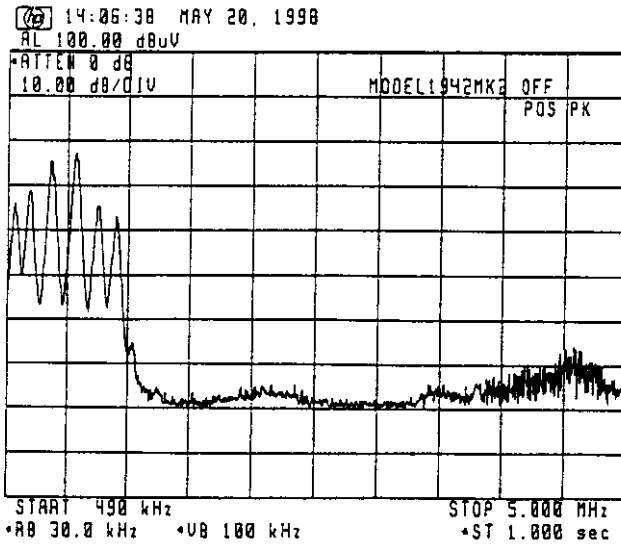

100 - 126 = -26 (0.5 MHz)  
 100 - 96 = 4 (3 MHz)  
 100 - 88 = 12 (5 MHz)

-20 dB $\mu$ V/m

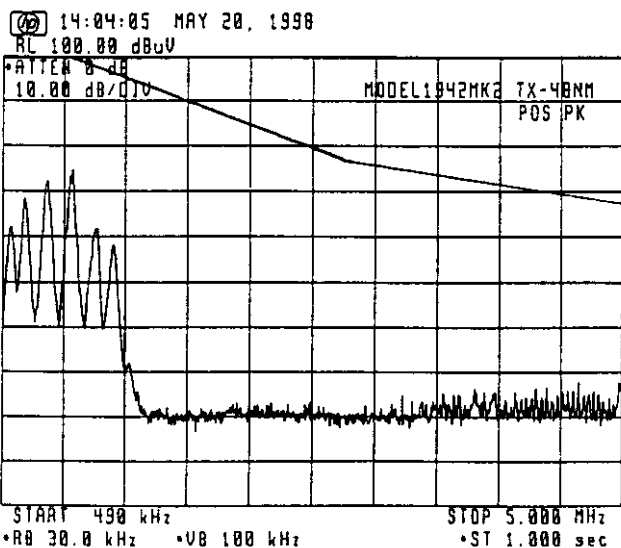

100 - 126 = -26 (0.5 MHz)  
 100 - 96 = 4 (3 MHz)  
 100 - 88 = 12 (5 MHz)

-20 dB $\mu$ V/m

Band: 5MHz ~ 10MHz (Limit at 1N.M. =  $0.1 \mu\text{V}/\text{m} = -20\text{dB}\mu\text{V}/\text{m}$ )

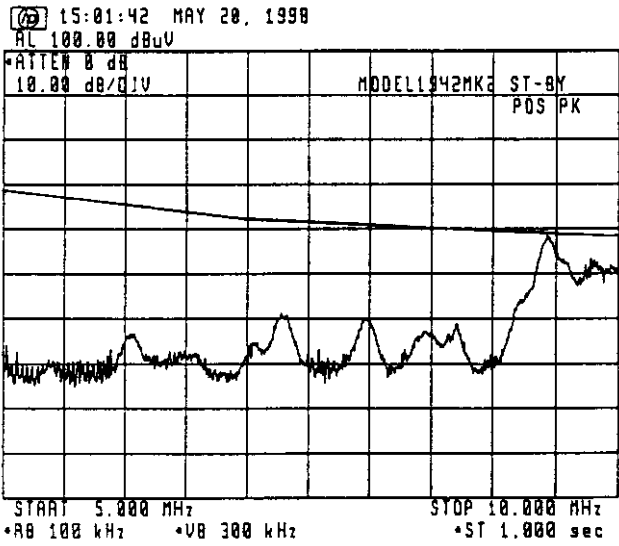
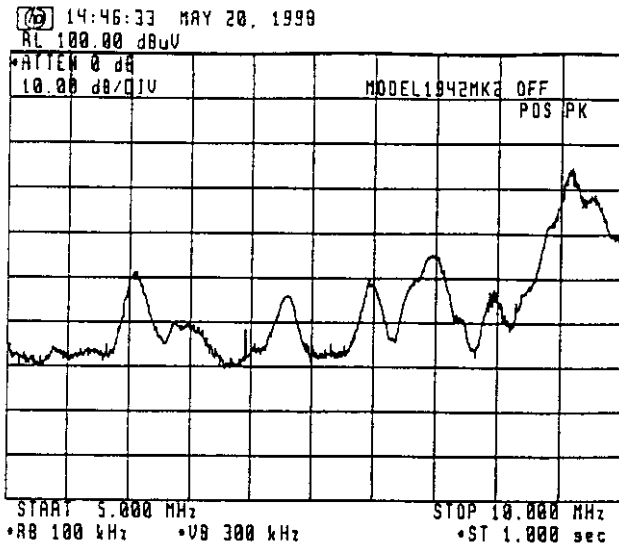

REF. (dBuV/m)  
 $100 - 88 = 12$  (5MHz)  
 $100 - 83 = 17$  (7MHz)  
 $100 - 78 = 22$  (10MHz)

-20dBuV/m

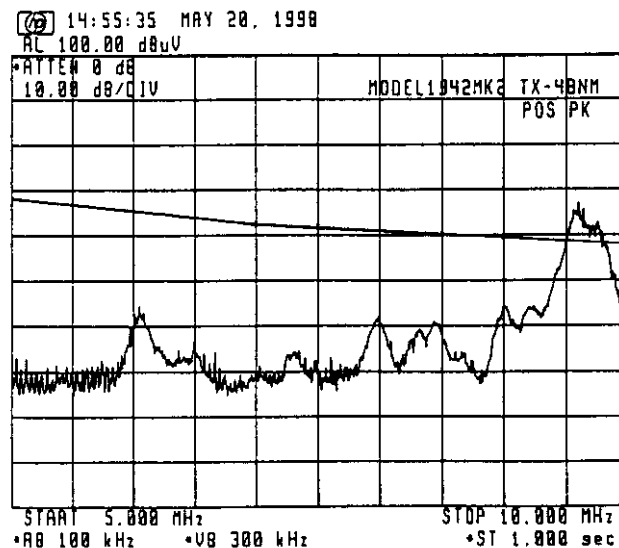

REF. (dBuV/m)  
 $100 - 88 = 12$  (5MHz)  
 $100 - 83 = 17$  (7MHz)  
 $100 - 78 = 22$  (10MHz)

-20dBuV/m

ALL COMPONENTS ABOVE  
 THE LIMIT ARE FROM  
 EXTERNAL NOISE OR SIGNALS,  
 NOT FROM RADAR.

Band = 10MHz ~ 30MHz (Limit at 1NM. = 0.1 $\mu$ V/m = -20dB $\mu$ V/m)

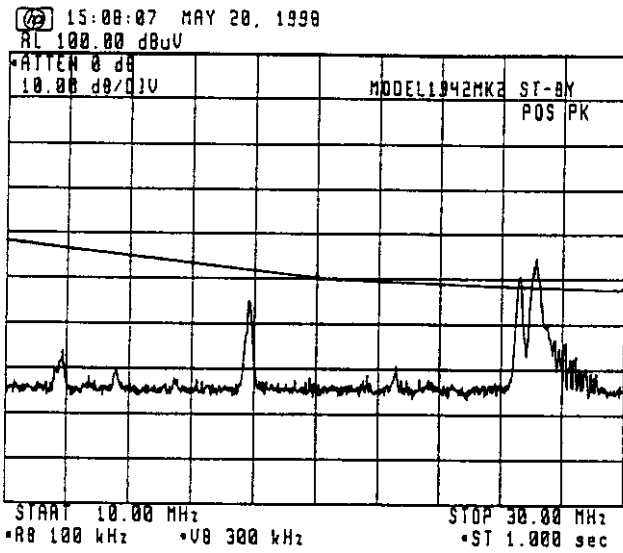
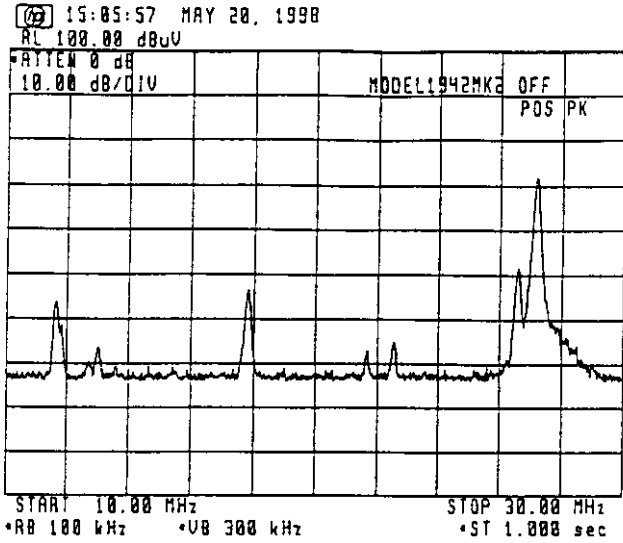

REF. (dB $\mu$ V/m)  
 100-78 = 22 (10MHz)  
 100-70 = 30 (20MHz)  
 100-67 = 33 (30MHz)

-20dB $\mu$ V/m  
 ALL COMPONENTS ABOVE  
 THE LIMIT ARE FROM  
 EXTERNAL NOISE OR SIGNALS,  
 NOT FROM RADAR.

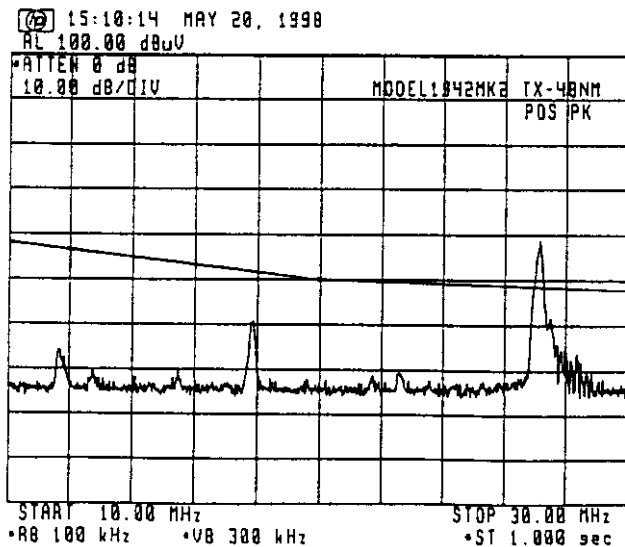

REF. (dB $\mu$ V/m)  
 100-78 = 22 (10MHz)  
 100-70 = 30 (20MHz)  
 100-67 = 33 (30MHz)

-20dB $\mu$ V/m

Band = 30MHz ~ 100MHz (Limit at 1N.M. =  $0.3 \mu\text{V/m} = -10.5 \text{ dB}\mu\text{V/m}$ )

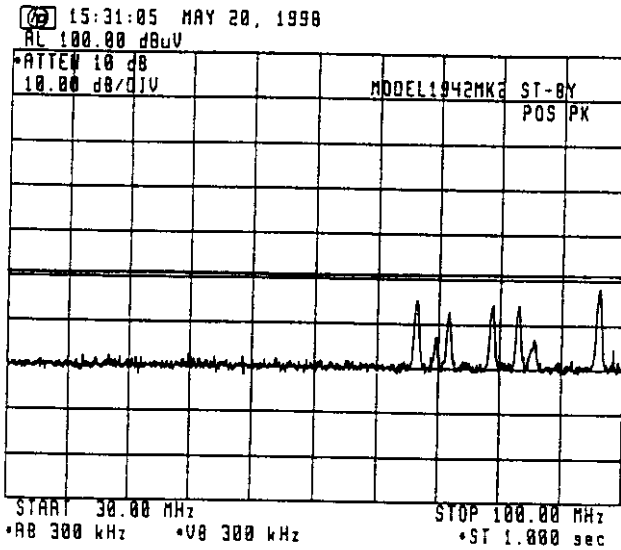
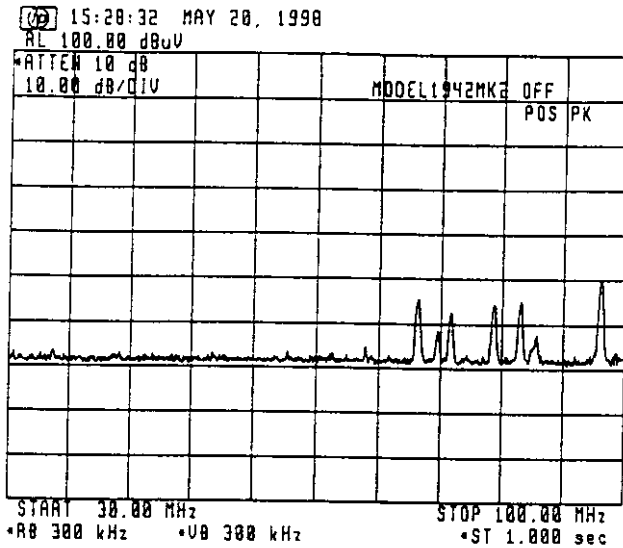

REF. (dB $\mu\text{V/m}$ )  
 $100 - 61 = 39$

-10.5 dB $\mu\text{V/m}$

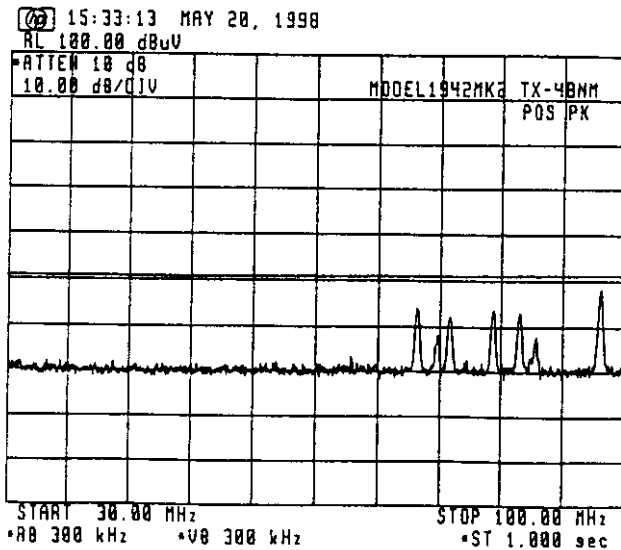

REF. (dB $\mu\text{V/m}$ )  
 $100 - 61 = 39$

-10.5 dB $\mu\text{V/m}$

Band = 100MHz ~ 300MHz (Limit at 1N.M. = 1 $\mu$ V/m = 0dB $\mu$ V/m)

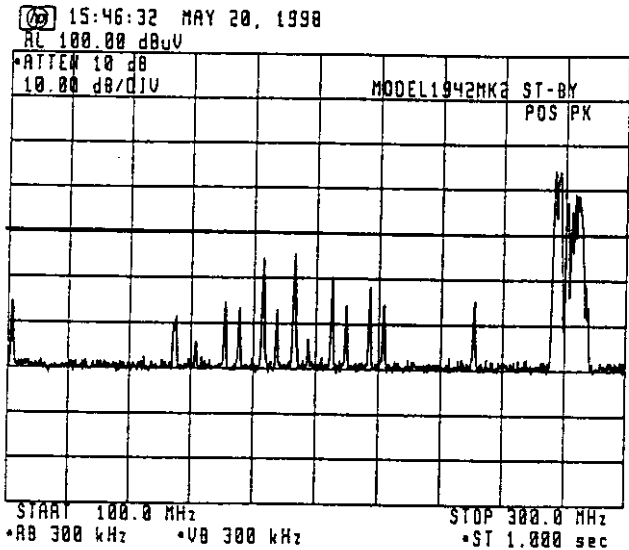
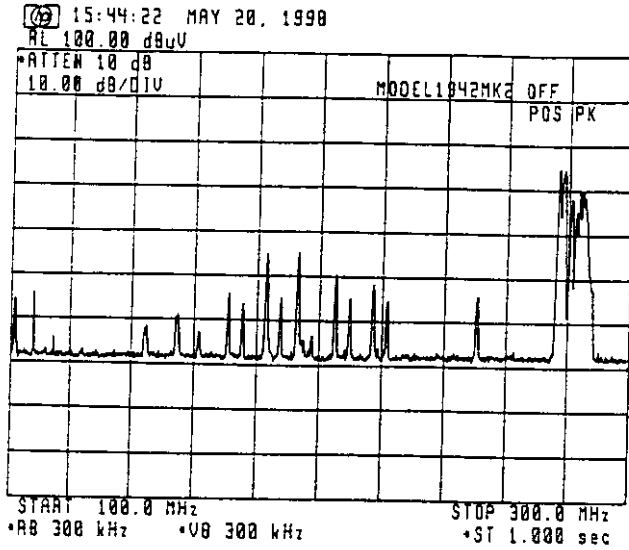

REF. (dB $\mu$ V/m)  
 100-60 = 40

0dB $\mu$ V/m  
 ALL COMPONENTS ABOVE  
 THE LIMIT ARE FROM  
 EXTERNAL NOISE OR SIGNALS,  
 NOT FROM RADAR.

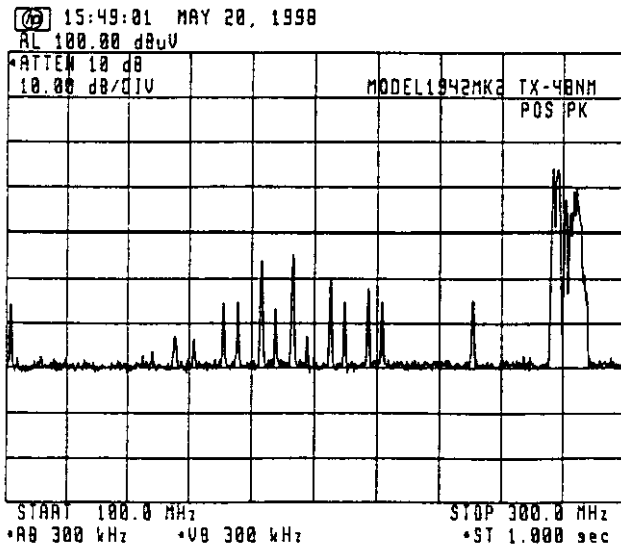

REF. (dB $\mu$ V/m)  
 100-60 = 40

0dB $\mu$ V/m

Band: 300MHz ~ 1GHz (Limit at 1N.M. =  $3\mu\text{V}/\text{m} = 9.5\text{dB}\mu\text{V}/\text{m}$ )

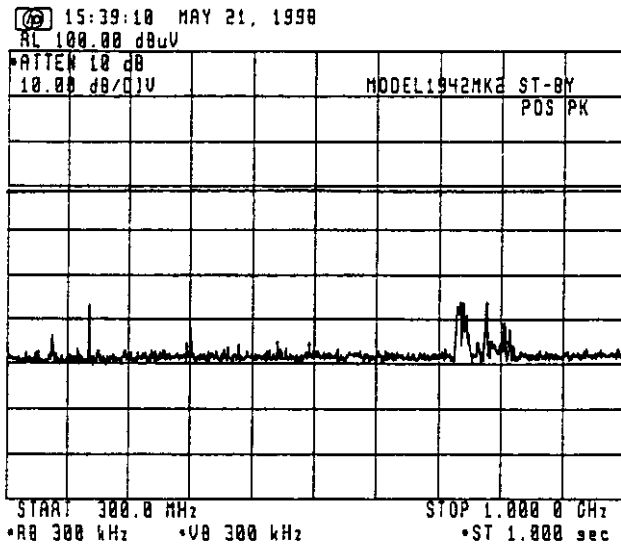
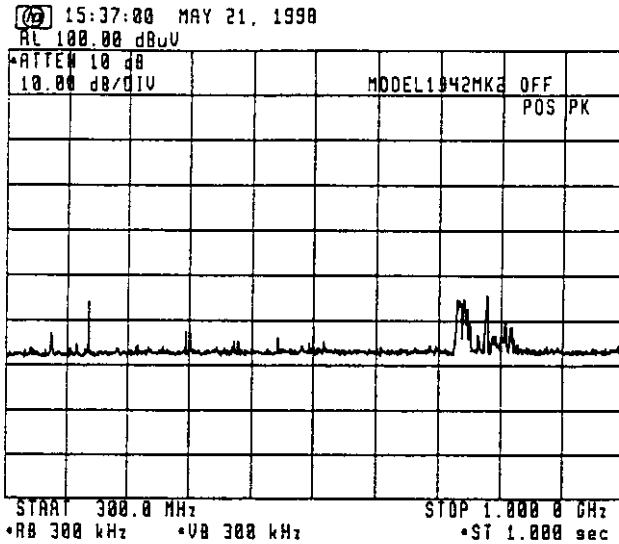

REF. (dB $\mu\text{V}/\text{m}$ )  
 $100 - 59.5 = 40.5$

9.5 dB $\mu\text{V}/\text{m}$

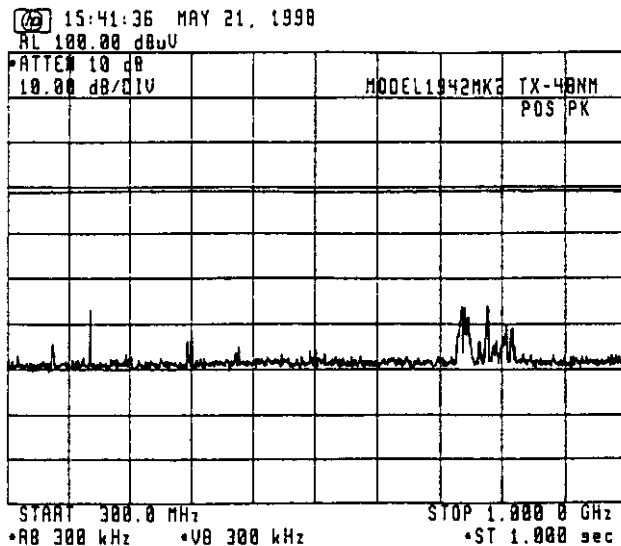

REF. (dB $\mu\text{V}/\text{m}$ )  
 $100 - 59.5 = 40.5$

9.5 dB $\mu\text{V}/\text{m}$

3. Power Input to an Artificial Antenna

Band: 14kHz ~ 490kHz (Limit at 2 meter = -81dBm)

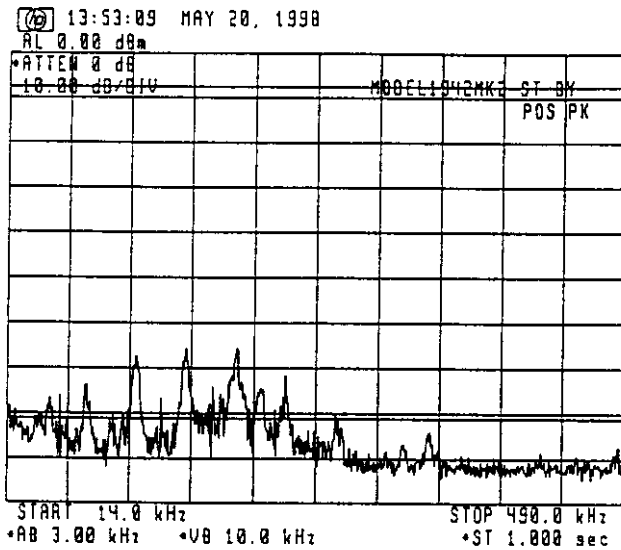
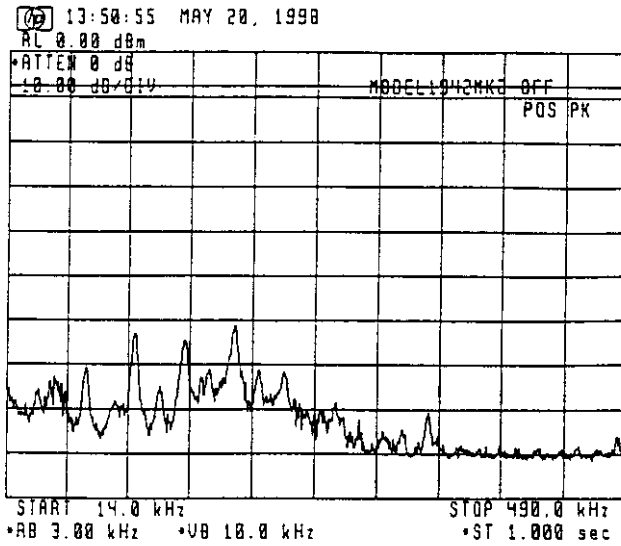

-81dBm  
ALL COMPONENTS ABOVE  
THE LIMIT ARE FROM  
EXTEPNAL NOISE OR SIGNALS,  
NOT FROM RADAR.

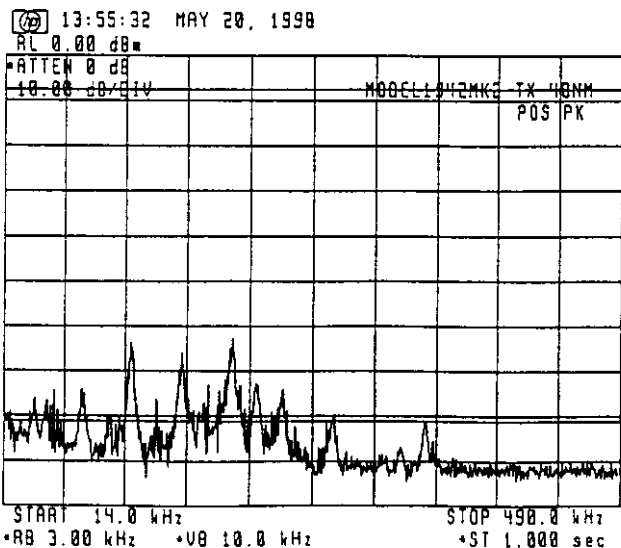

-81dBm

Band = 490kHz ~ 5MHz (Limit at 2meter = -81dBm)

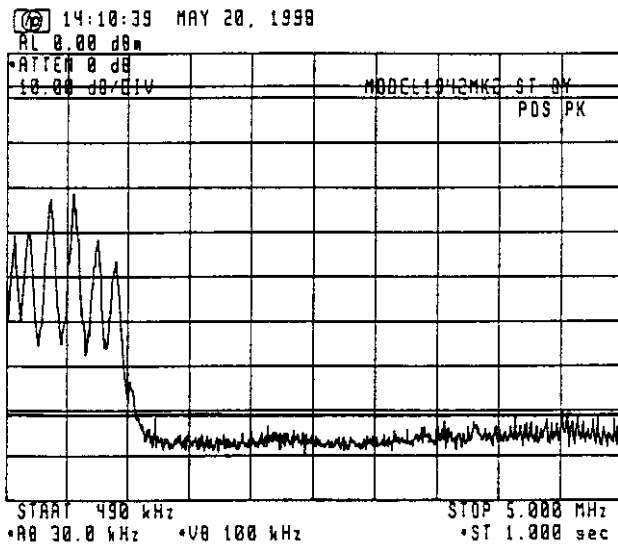
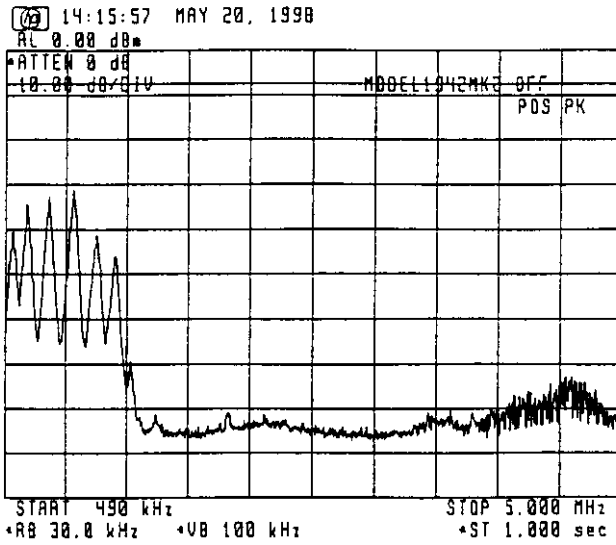

-81dBm  
ALL COMPONENTS ABOVE  
THE LIMIT ARE FROM  
EXTEPNAL NOISE OR SIGNALS,  
NOT FROM RADAR.

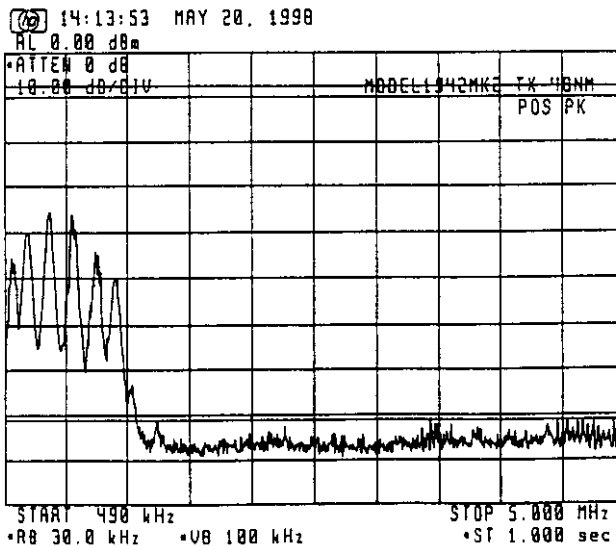

-81dBm



Band: 5MHz ~ 10MHz (Limit at 2 meter = -81dBm)

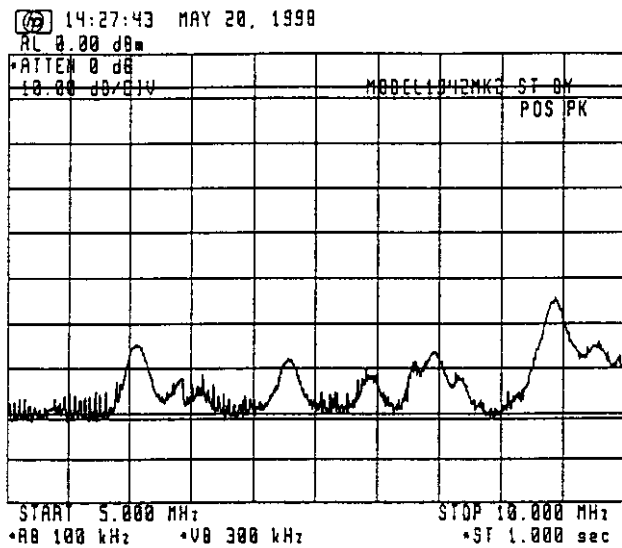
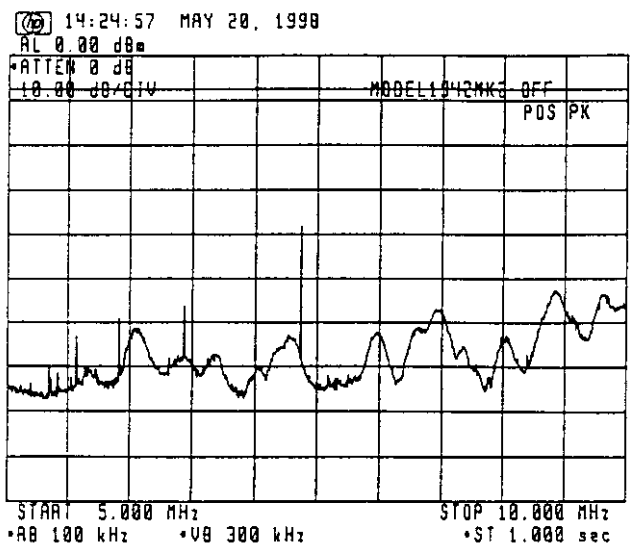

- 81dBm  
ALL COMPONENTS ABOVE  
THE LIMIT ARE FROM  
EXTEPNAL NOISE OR SIGNALS,  
NOT FROM RADAR.

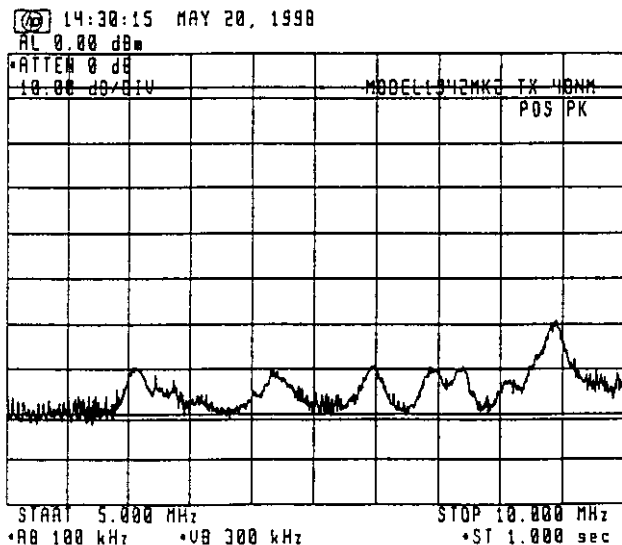

- 81dBm

Band: 10MHz ~ 30MHz (Limit at 2 meter = -81dBm)

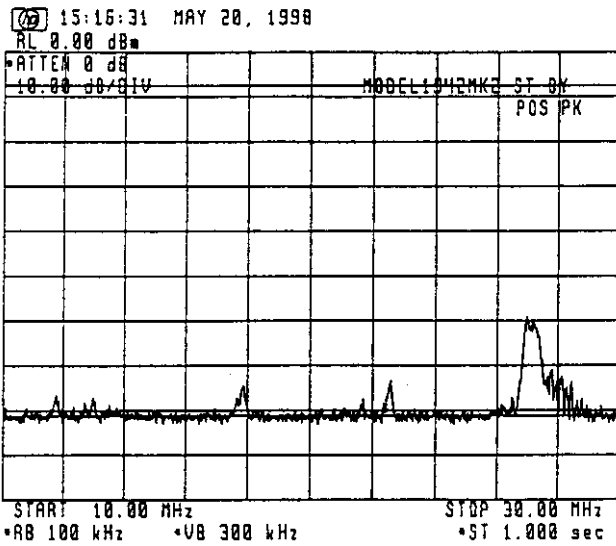
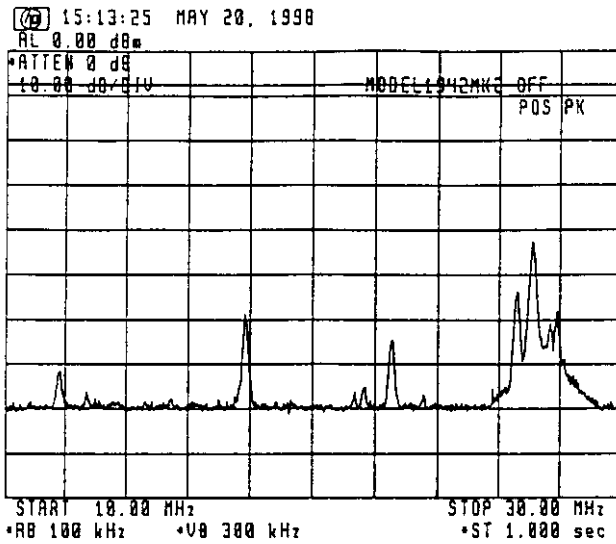

-81dBm  
ALL COMPONENTS ABOVE  
THE LIMIT ARE FROM  
EXTERNAL NOISE OR SIGNALS,  
NOT FROM RADAR.

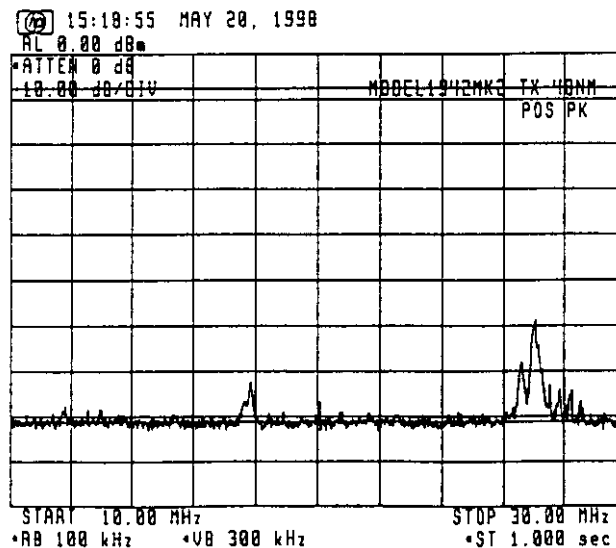

-81dBm

Band: 30MHz ~ 100MHz (Limit at 2 meter = -71dBm)

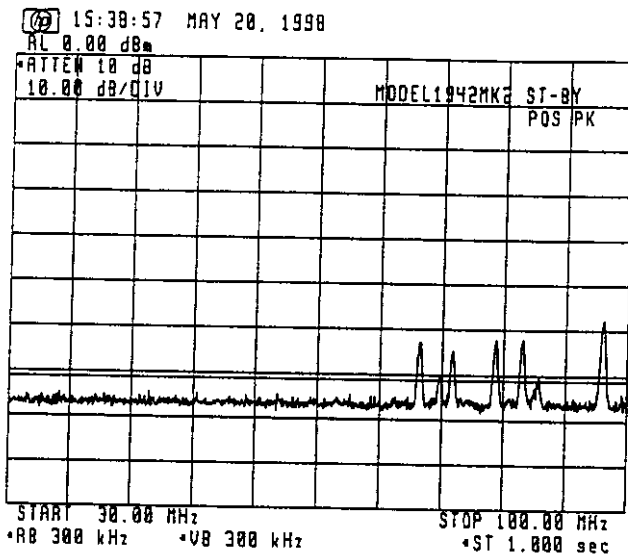
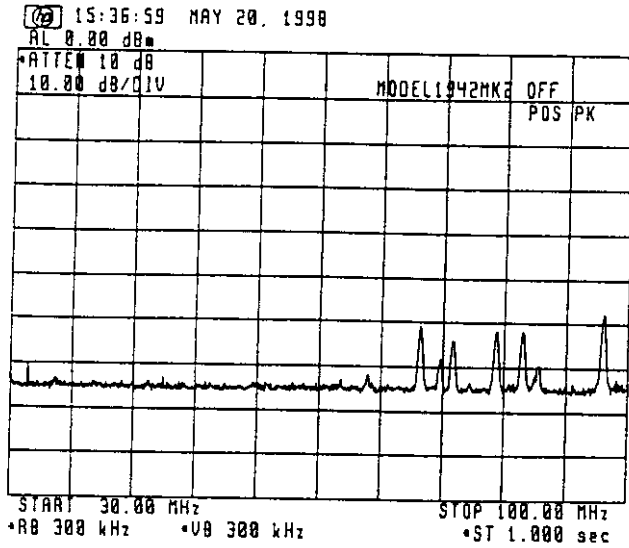

- 71 dBm  
ALL COMPONENTS ABOVE  
THE LIMIT ARE FROM  
EXTERNAL NOISE OR SIGNALS,  
NOT FROM RADAR.

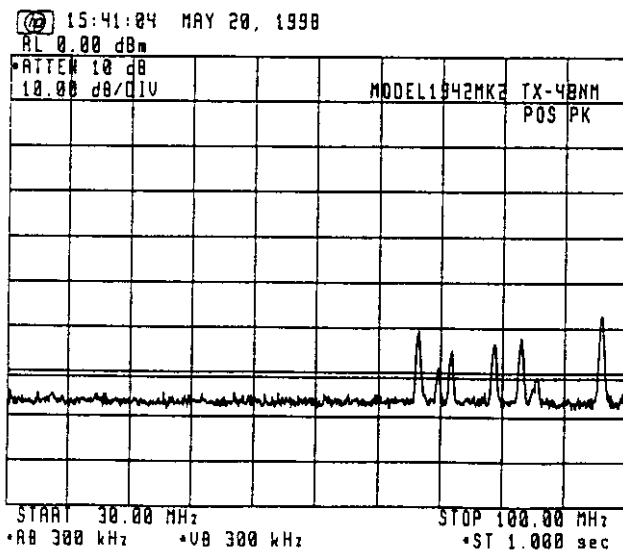

- 71 dBm

Band = 100MHz ~ 300MHz (Limit at  $\rightarrow$  meter = -61dBm)

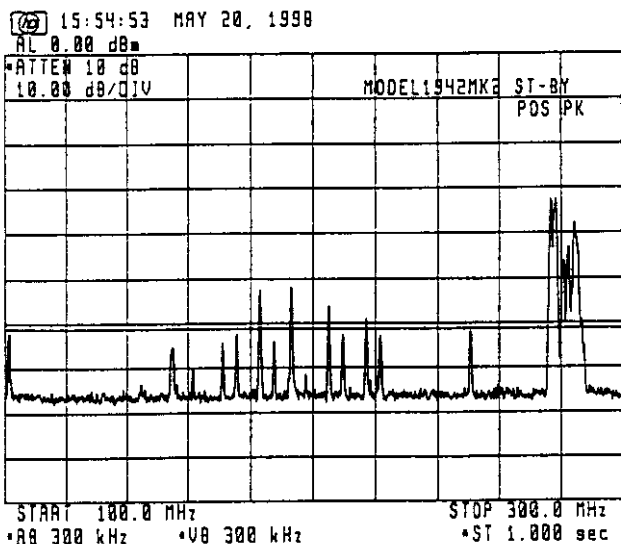
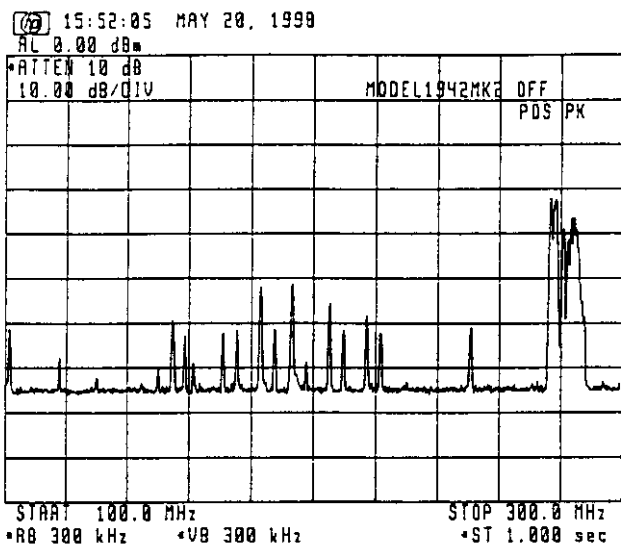

-61dBm  
ALL COMPONENTS ABOVE  
THE LIMIT ARE FROM  
EXTERNAL NOISE OR SIGNALS,  
NOT FROM RADAR.

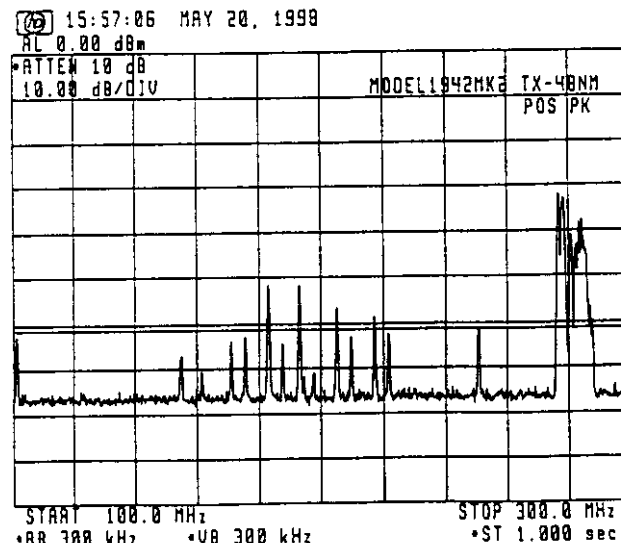

-61dBm

Band = 300MHz ~ 1GHz (Limit at 2meter = -51dBm)

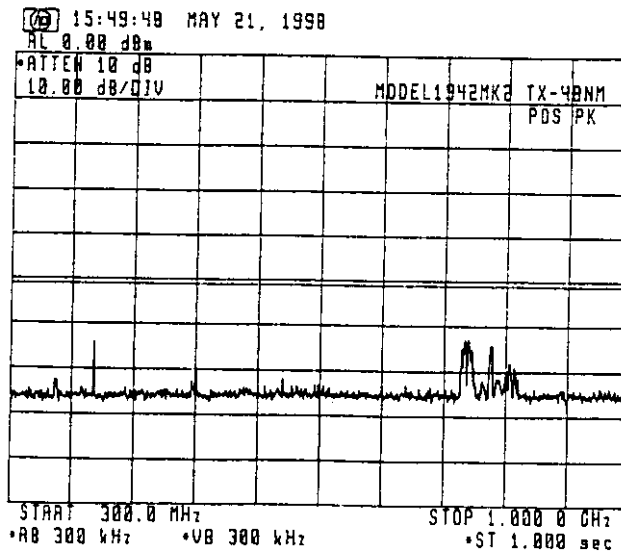
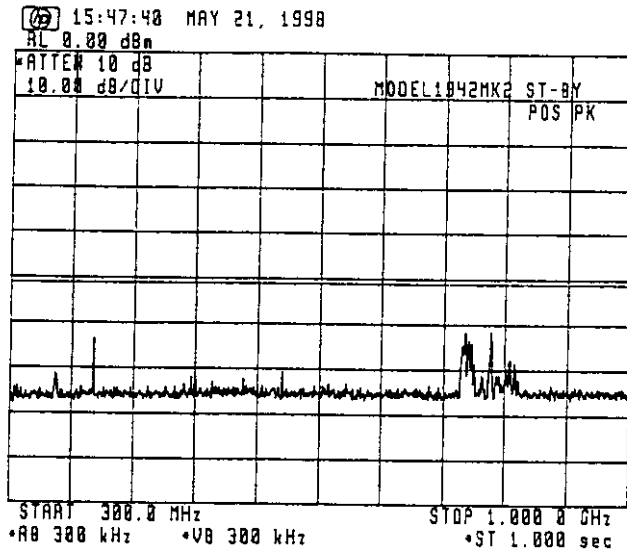
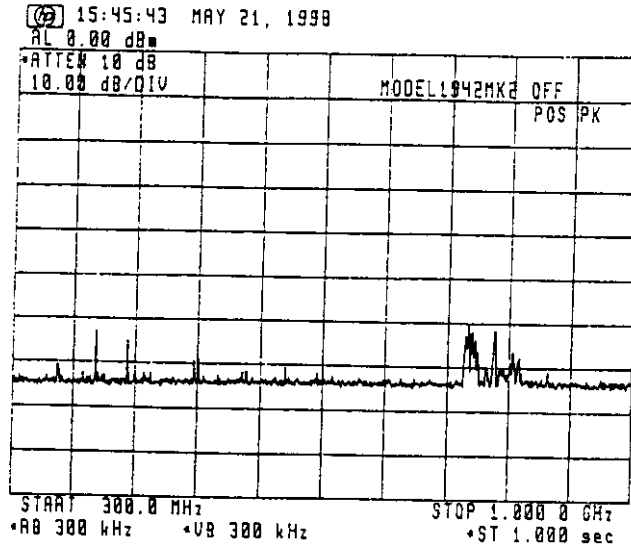



**ATTACHMENT 4 [ List of Test/Measuring Equipment ]**

**3. RF Power Output**

<u>Model</u>	<u>Type</u>	<u>Serial no.</u>	<u>Mfr.</u>
Spectrum Analyzer	71210C	2927A02847	HP
Oscilloscope	COS6100A	2440652	KIKUSUI
Directional Coupler	----	R94471	Shimada
Directional Coupler	5D364S	R05762	Shimada
Voltage Divider	P6015	----	Tektronix
Current Transformer	2100	----	Pearson Electronics
Power Meter	436A	2410A19137	HP
Power Sensor	9481A	2349A39603	HP
Frequency Counter	TR5824A	41940036	Advantest
Frequency Meter	X532B	1441A00523	HP
Crystal Detector	423B	03696	HP
Step Attenuator	8494B	1510A07310	HP
Step Attenuator	8495B	1350A04754	HP
Dummy Load	----	8411057	Shimada

**4. Modulation Characteristics**

<u>Model</u>	<u>Type</u>	<u>Serial no.</u>	<u>Mfr.</u>
Oscilloscope	COS6100A	2440652	KIKUSUI
Step Attenuator	8494B	1510A07310	HP
Step Attenuator	8495B	1350A04754	HP
Crystal Detector	423B	1822A24214	HP
Directional Coupler	5D364S	R9425	Shimada
Dummy Load	-----	8411057	Shimada
Voltage Divider	P6015	----	Tektronix
Spectrum Analyzer	71210C	2927A02847	HP
External Mixer:	11970K	----	HP
External Mixer:	11970A	----	HP
Directional Coupler	5D364S	R9425	Shimada

Pub. No.: TI-1696

Date: July, 1998

## 6. Spurious Emissions at Antenna Terminal

<u>Model</u>	<u>Type</u>	<u>Serial no.</u>	<u>Mfr.</u>
Spectrum Analyzer	71210C	2927A0847	HP
Attenuator (11dB/1dB)	8494B	1510A07310	HP
External Mixer:	11970K	----	HP
External Mixer:	11970A	----	HP
Directional Coupler	5D364S	R0576	Shimada
Dummy Load	----	8411057	Shimada
Notch Filter	MA8L32#8	----	Microwave
High Pass Filter	MAS15905004	R9904	Shimada

## 7. Field Strength of Spurious Radiation

<u>Model</u>	<u>Type</u>	<u>Serial no.</u>	<u>Mfr.</u>
Broadband Rod Antenna	M 95010-1	0496	Advanced Electronics
Biconical Antenna	BIA-25	2650	Electro Metrics
Conical Log-Spiral Antenna	LCA-25	2886	Electro Metrics
Double Ridged Guide Horn Antenna:RGA-180	----	----	EMD
Horn Antenna:	----	----	Toshiba
Spectrum Analyzer:	71210C	2927A0287	HP
External Mixer:	11970K	----	HP
External Mixer:	11970A	----	HP

## 8. Frequency Stability

<u>Model</u>	<u>Type</u>	<u>Serial no.</u>	<u>Mfr.</u>
Power Meter:	436A	2410A19137	HP
Power Sensor:	8481A	2349A39603	HP
Frequency Meter:	X532B	1441A00523	HP
Directional Coupler:	5D364S	R9425	Shimada
Dummy Load:	----	8411057	Shimada
Environmental Chamber:	PL-4E	1632712	Tabai Espec



Pub. No. : TI-1696

Date : July, 1998

### 9. Suppression of Interference Aboard Ships

<u>Model</u>	<u>Type</u>	<u>Serial no.</u>	<u>Mfr.</u>
Spectrum Analyzer:	71210C	2927A02847	HP
6 m Whip Antenna	14 k - 10 MHz	----	Furuno
4 m Whip Antenna	10 - 30 MHz	----	Furuno
VHF Whip Antenna	30 - 300 MHz	150M-W2UM	Anten
UHF Whip Antenna	300 - 1000 MHz	----	Anten
RF Vector Impedance Meter:	4815A	2048A03354	HP
Spectrum Analyzer	TR4172	30690116	Advantest
Spectrum Analyzer	8566B	2637A03642	HP

