

Pub.No.: TI-1697

Date: July, 1998

FURUNO®

TECHNICAL INFORMATION

**TEST REPORT ON THE PERFORMANCE OF
MARINE RADAR**

MODEL 1932 MARK-2

FURUNO ELECTRIC CO., LTD.
NISHINOMIYA CITY, JAPAN



Pub. No. : TI-1697

Date : July, 1998

July 22, 1998

All data herein contained is true and correct to my best knowledge.

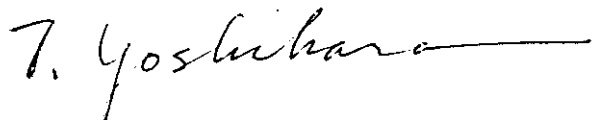

T. Yoshihara

Manager

Radio Navigation & Communication Section 2

Research & Development Department

Marine Product Division

FURUNO ELECTRIC CO., LTD.

Personal History

Born: January 29, 1944

Graduated: Osaka University
Electric Engineering Faculty

Occupation: Joined FURUNO ELECTRIC CO., LTD. in April 1967, since then engaged in the development of radar equipment.



***** CONTENTS *****

1 General Information.....	4
2 Identification of Equipment.....	10
3 RF Power Output.....	11
4 Modulation Characteristics	14
5 Occupied Bandwidth.....	19
6 Spurious Emissions at Antenna Terminal.....	21
7 Field Strength of Spurious Radiation	25
8 Frequency Stability	29
9 Suppression of Interference Aboard Ships.....	32
10 Photographs to Reveal Equipment Construction and Layout	38
11 Technical Description of Equipment	46
11.1 FUNCTION OF EACH SEMICONDUCTOR OR ACTIVE DEVICE	46
11.2 DESCRIPTION OF THE CIRCUITS EMPLOYED FOR SUPPRESSION OF SPURIOUS RADIATION, FOR LIMITING OR SHAPING THE CONTROL PULSE, AND FOR LIMITING OR CONTROLLING POWER.....	49
12 Operator's Manual incl. Circuit Diagrams	52
Attachment 1 [Test data for <u>6. Spurious Emissions at Antenna Terminal</u>]	A1
Attachment 2 [Test data for <u>7. Field Strength of Spurious Radiation</u>]	A2
Attachment 3 [Test data for <u>9. Suppression of Interference Aboard Ships</u>]	A3
Attachment 4 [List of Test/Measuring Equipment]	A4



1 GENERAL INFORMATION

1.1 General

- (a) Manufacturer: Furuno Electric Co., Ltd.
Ashihara-cho 9-52, Nishinomiya-city, 662-8580 Japan
- (b) Model: Model 1932 MARK-2
Serial no.: 3379-0001
- (c) Primary Function: Search, navigation and anticollision
- (d) Maximum Range Scale: 48 nm
- (e) Discrimination
Range Discrimination: less than 35 meters on a range scale of 1.5 nm
Bearing Discrimination: Better than 2.5 ° on a range scale of 1.5 nm
- (e) Minimum Range: less than 35 meters on a range scale of 0.25 nm
- (f) Frequency Range: Fixed frequency, X-band
Type of Emission: P0N
- (g) Power Supply: 12/24/32 VDC

1.2 Transmitter

- (a) Assignable Frequency for Shipborne Radar:
Between 9300 and 9500 MHz (FCC Rule § 80.375 (d)-(1))
- (b) Type of RF Generator
Magnetron Type: MG5388 , E3571 or MAF1421B
Peak Output Power: 4 kW nominal
- (c) Magnetron Ratings
Center frequency of Magnetron: 9410 MHz
Tolerances
- | | <u>MG5388</u> | <u>E3571</u> | <u>MAF1421B</u> |
|---|---------------|--------------|-----------------|
| Manufacturing: | ±30 MHz | ±30 MHz | ±30 MHz |
| Pulling: | 23 MHz | 18 MHz | 23 MHz |
| Tolerance for 20° C
temperature variation: | 5 MHz | 5 MHz | 5 MHz |
- (d) Guard Band:
Guard Band is specified to be equal to 1.5/T MHz, where "T" is the pulselength in microseconds. See para (e). (FCC Rule § 80.209)

(e) Pulse Characteristics:

Pulse Type	Short	Middle	Long
Range Scale (nm)	0.125 <u>0.25</u> 0.5 0.75 1 1.5	1.5 <u>2</u> 3	3 4 6 8 12 16 24 36 <u>48</u>
Output pulselength (μ s)	0.08	0.30	0.80
P.R.R. (Hz)	2100	1200	600
Duty cycle	1.68E-4	3.60E-4	4.80E-4
Guard Band (MHz)	18.75	5.00	1.88

Note: Tests were carried out for the underlined Range Scales.

1.3 Modulator

- (a) FET Type: 2SK1450
 Trigger Voltage: Approx. +20 VDC

1.4 Receiver

- (a) Passband

IF Stage:

Pulse Type	Short	Middle	Long
(MHz)	25	25	5

- (b) Gain (overall) (dB): Sufficient to cause limiting, approximately 130

- (c) Overall Noise Figure (dB): 6 (typical)
- (d) Video Output Voltage (V): 3.8 positive across 400 ohms
- (e) Features Provided: Sensitivity Time Controls (Anti-clutter Sea),
Fast Time Constant (Anti-clutter Rain)
- (f) If receiver is tunable, describe method of adjusting frequency:
Adjustment of tuning voltage of receiver local oscillator (Automatic)

1.5 Display

- (a) Type: 10 (in.) mono-color (green),
PPI, raster scan.
- (b) Size of Indicator Tube: 10 in. diagonal CRT
effective dia., 130 mm
- (c) Sweep Linearity: 2 % on all ranges
- (d) Range Scales:

Range (nm)	Number of Range Rings	Range Ring Interval (nm)
0.125	2	0.0625
0.25	2	0.125
0.5	4	0.125
0.75	3	0.25
1	4	0.25
1.5	3	0.5
2	4	0.5
3	3	1
4	4	1
6	3	2
8	4	2
12	4	3
16	4	4
24	4	6
36	3	12
48	4	12

- (e) Range Ring Accuracy: Better than 0.9 % of maximum scale in use
or 8 m, whichever is the greater
- (f) Overall Bearing Accuracy from Scanner to Display:
Better than 1°

- (g) Target Plot Facility: Simulated afterglow in low shade
- (h) Heading Indicator: Provided, automatic alignment.
- (i) True Bearing Indicator: Provided.

1.6 Antenna

- (a) Antenna Rotation ON-OFF Switch:
Not provided.

- (b) Reflector: Slotted waveguide array,

Radiator Type	XN8
Length (cm)	100
Length (ft)	3

- (c) Type of Beam: Vertical fan
- (d) Beam Width (between half-Radiator power points)

Radiator Type	XN8
Horizontal	2.4°
Vertical	27 °

- (e) Polarization: Horizontal

- (f) Antenna Gain:

Radiator Type	XN8
(dB)	26

- (g) Attenuation of Major Side Lobes with respect to main beam:

Within $\pm 20^\circ$, 24 dB

Outside $\pm 20^\circ$, 30 dB

- (h) Scanning (rotating or oscillating): Rotating over 360° continuously
clockwise

- (i) Antenna Rotation Rate: 24 rpm (for RSB-0082)
48 rpm (for RSB-0083)

- (j) Number of Degrees Scanned: 360°

- (k) Sector Scan: Not provided. Sector blanking available.

- (l) Type of Transmission System: Contained in scanner unit

- (m) Rated Loss of Transmission System per hundred feet:

None. Transmission path is only in the antenna scanner unit.

1.7 Line Power Supply Requirements

- (a) Input Voltage: 12/24/32 VDC
- (b) Power Drain: 61 W

1.8 Functional Controls

- | | | |
|---------------------------------|------------------------|----------------------------|
| *Range selector | *Tune (manual) | *EBL offset |
| *Power save | *Anti-clutter auto | *Power Switch |
| *A/C Sea control | *Gain control | *Panel dimmer |
| *Heading line off | *Echo stretch | *MENU |
| *Guard zone set/Audio alarm off | *Range ring brilliance | *Noise rejector on/off |
| *Interference rejector | *STBY/TX | *Trackball (VRM,EBL,GUARD) |
| *VRM on/off | *Off-center (SHIFT) | *A/C Rain control |
| *Range set | *Zoom | *EBL on/off |
| *Target trail | *Brilliance (screen) | *TRU/REL |
| *Navigation on/off | *Mark Brilliance | *Function #1- #2 |
| *Range ring on/off | *Text Brilliance | *HU/CU/NU/TM mode |
| *ARPA function(option) | *Watchman | |

1.9 Construction Features

- (a) Does equipment embody replacement units with chassis type assembly:
Yes
- (b) Are fuse alarms provided: Fuses are provided.
- (c) State units which are weatherproof: Scanner Unit (IEC 529/IPX6)
- (d) If all units are not housed in a single container, indicate number and give description of individual units:

1 × Display Unit	Type:	RDP-118
1 × Scanner Unit	Type:	RSB-0082 (24 V, 24 rpm)
		RSB-0083 (24 V, 48 rpm)
(Transceiver	Type:	RTR-064 (contained in the Scanner unit))
- (e) Approximate Weight of Complete Installation:

Display Unit:	8 kg	
Scanner Unit:	23 kg	(XN8-RSB-0082/83)
- (f) Approximate space required for installation excluding scanner:

Display Unit:	472 mm (W) X 298 mm (H) X 367 mm (D)
---------------	--------------------------------------

Pub. No. : TI-1697

Date : July, 1998

1.10 Operational Features

- (a) Is positive means provided to indicate whether or not the overall operation of the equipment is such that it may be relied upon to provide effective operation in accordance with its primary function:

Magnetron/Xtal checker

- (b) Is the equipment for continuous operation:

Yes

- (c) Is provision made for operation with shore based radar beacons (RACONS):

Yes (RACONS and SART)

2 IDENTIFICATION OF EQUIPMENT (FCC Rule § 2.925)

The following nameplates are permanently fixed on the corresponding equipment units.

FCC ID: ADB9ZW1932M2

Material of nameplate: Polyester, 0.1 mm thick

MARINE RADAR	
[REDACTED]	
SCANNER UNIT	
TYPE	RSB-0082
SER. NO.	R097-
COMPASS SAFE DISTANCE	
STD [REDACTED] M	STEER [REDACTED] M
EQUIPMENT CLASS [REDACTED]	
FURUNO ELECTRIC CO., LTD.	
NISHINOMIYA CITY, MADE IN JAPAN	

Fig. 2.1
Nameplate for
Scanner unit
at RSB-0082

MARINE RADAR	
[REDACTED]	
SCANNER UNIT	
TYPE	RSB-0083
SER. NO.	R098-
COMPASS SAFE DISTANCE	
STD [REDACTED] M	STEER [REDACTED] M
EQUIPMENT CLASS [REDACTED]	
FURUNO ELECTRIC CO., LTD.	
NISHINOMIYA CITY, MADE IN JAPAN	

Fig. 2.2
Nameplate for
Scanner unit
at RSB-0083

MARINE RADAR	
MODEL	1932 MARK-2
DISPLAY UNIT	
TYPE	RDP-118
INPUT	10.2 - 41.6 VDC
SER. NO.	3379 -
FCC ID: ADB9ZW1932M2	
FURUNO U.S.A., INC.	
COMPASS SAFE DISTANCE	
STD [REDACTED] M	STEER [REDACTED] M
EQUIPMENT CLASS [REDACTED]	
FURUNO ELECTRIC CO., LTD.	
NISHINOMIYA CITY, MADE IN JAPAN	

Fig. 2.3
Nameplate for
Display unit

3 RF POWER OUTPUT (FCC Rule §2.985)

3.1 Microwave characteristics

The peak voltage was determined using the divider having a ratio of 1000 to 1 and the oscilloscope. Current pulse was viewed across the wideband current transformer with output voltage per ampere 1.00.

Nominal values

Pulse Type	Short	Middle	Long
Range scale (nm)	0.25	2	48
Pulselength (μs)	0.08	0.30	0.80
PRR (Hz)	2100	1200	600
Duty cycle	1.68E-4	3.60E-4	4.80E-4
Guard band (MHz)	18.75	5.00	1.88

Measured values

Magnetron input pulse voltage was measured at its cathode using the oscilloscope and divider with ratio 1000 to 1.

Pulse Type	Short	Middle	Long
Directional coupler attenuation (dB)	40.54	40.54	40.54
Magnetron input voltage (kV)	3.80	3.60	3.60
Pulselength (μs) (50 % amplitude)	0.240	0.400	0.920
Rise time (μs) (10-90 % amplitude)	0.060	0.055	0.055
Decay time (μs) (90-10 % amplitude)	0.740	0.640	0.250

Magnetron input pulse current

Magnetron input pulse current was observed across the wideband current transformer with output voltage per ampere 1.00.

Pulse Type	Short	Middle	Long
Magnetron input current (A)	3.2	3.3	3.3

Pulse Type	Short	Middle	Long
Pulselength (μ s) (50 % amplitude)	0.110	0.300	0.820
Rise time (μ s) (10-90 % amplitude)	0.060	0.065	0.065
Decay time (μ s) (90-10 % amplitude)	0.060	0.060	0.065

RF envelope of the magnetron output pulse

The RF envelope of the magnetron output pulse was measured using a diode and the oscilloscope with the following results:

Pulse Type	Short	Middle	Long
Pulselength (μ s) (-3 dB points)	0.108	0.305	0.805
Rise time (μ s) (10-90 % amplitude)	0.008	0.010	0.010
Decay time (μ s) (90-10 % amplitude)	0.055	0.055	0.055

Estimated efficiency

The estimated efficiency of the RF generator (magnetron) was determined by the following measurements and calculation. Power output from magnetron was measured using the directional coupler, power meter and the oscilloscope.

Pulse Type	Short	Middle	Long
Range scale (nm)	0.25	2	48
PRR (Hz)	2234.7	1257.0	566.5
Duty cycle	2.41E-4	3.83E-4	4.56E-4
Magnetron input, av. (W)	2.93	4.55	5.42
Magnetron input, peak (kW)	12.16	11.88	11.88
Power meter reading (mW)	0.0807	0.121	0.151
Magnetron output, av. (W)	0.914	1.370	1.710
Spurious response limits (dB)	42.61	44.37	45.33
Magnetron Output, peak (kW):	3.79	3.57	3.75
Magnetron efficiency (%):	31.1	30.1	31.6

Pub. No. : TI-1697

Date : July, 1998

Peak Power Input to RF Generator : 11.97 kW

Estimated Efficiency of RF Generator : 30.9 %

4 MODULATION CHARACTERISTICS (FCC Rule § 2.987)

4.1 FET Trigger Pulse

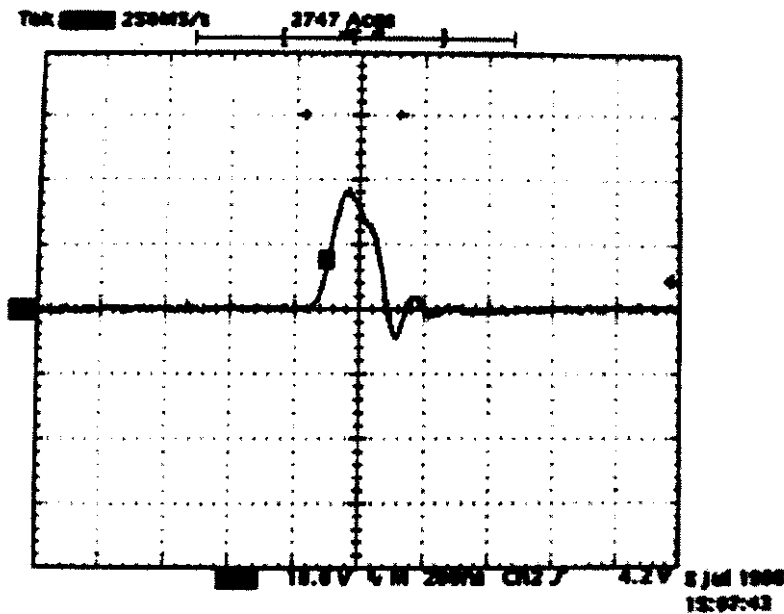

Fig. 4.1

(Typical wave form of Trigger Pulse)
Short Pulse (0.25 nm Range)

Scale: 10 V/div.
200 ns/div.

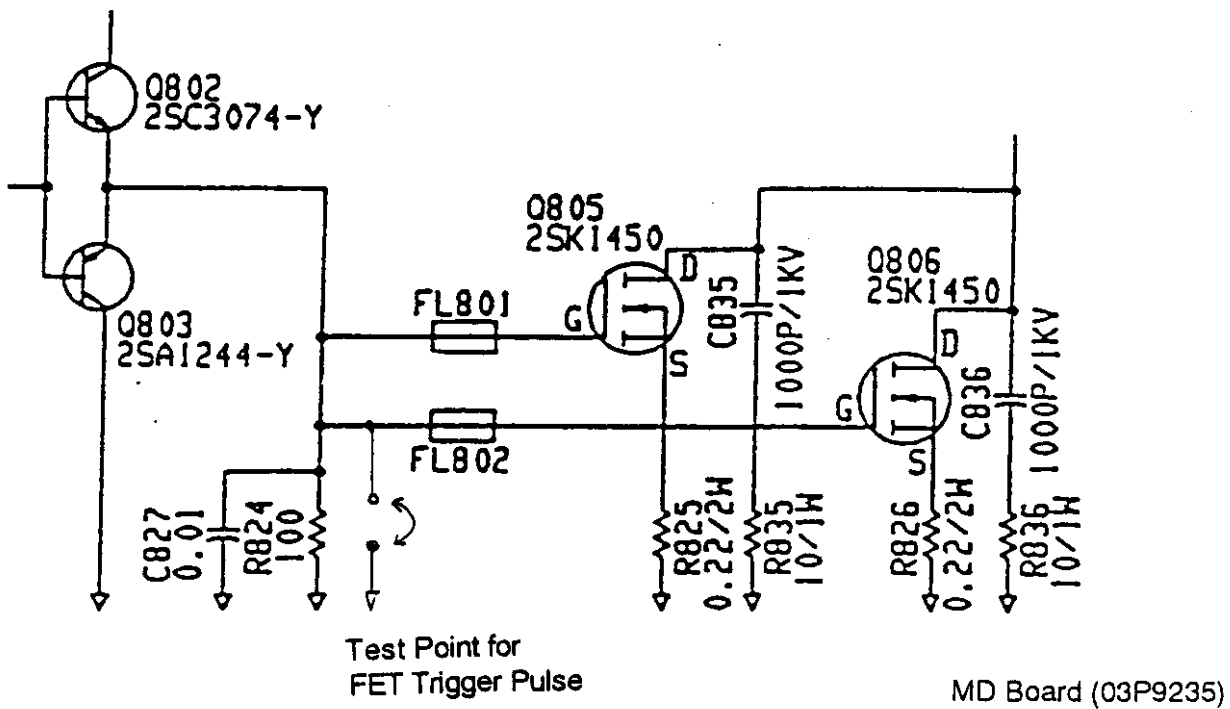

Fig. 4.1.2 Test Point for Trigger Pulse

4.2 Trigger Pulse at Magnetron Cathode

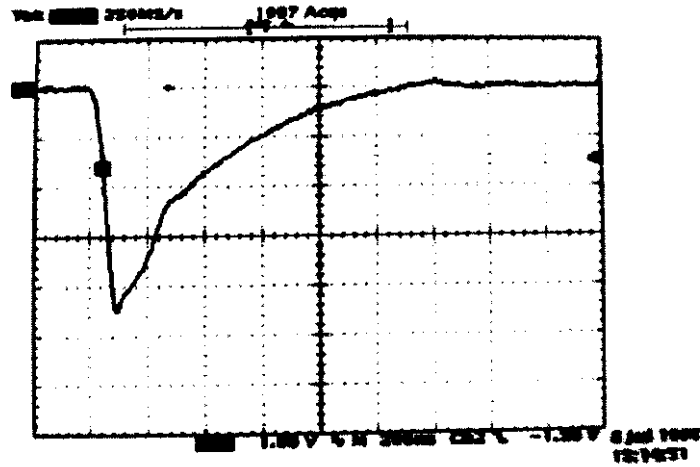

Fig. 4.2.1

Short Pulse (0.25 nm Range)

Scale: 1 kV/div. 200 ns/div.

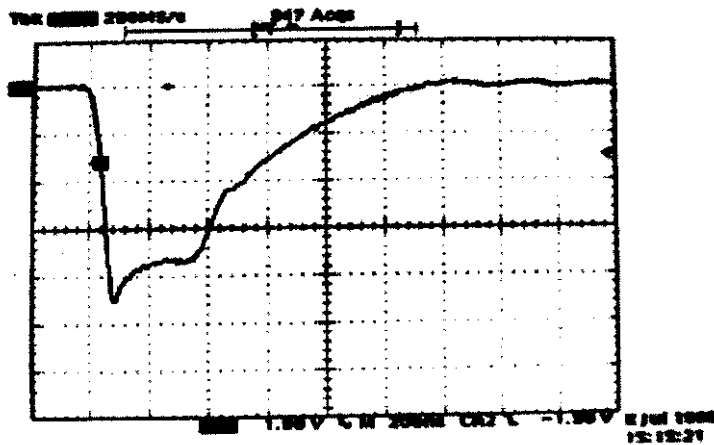

Fig. 4.2.2

Middle Pulse (2 nm Range)

Scale: 1 kV/div. 200 ns/div.

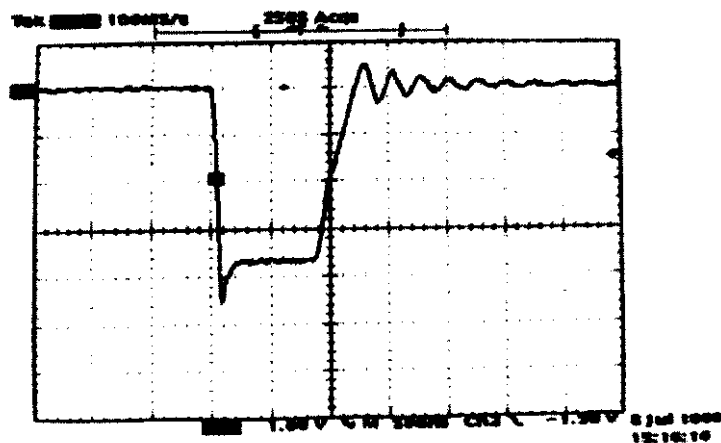

Fig. 4.2.3

Long Pulse (48 nm Range)

Scale: 1 kV/div. 500 ns/div.

4.3 Magnetron Output (detected):

4.3.1 Setup for Measurement:

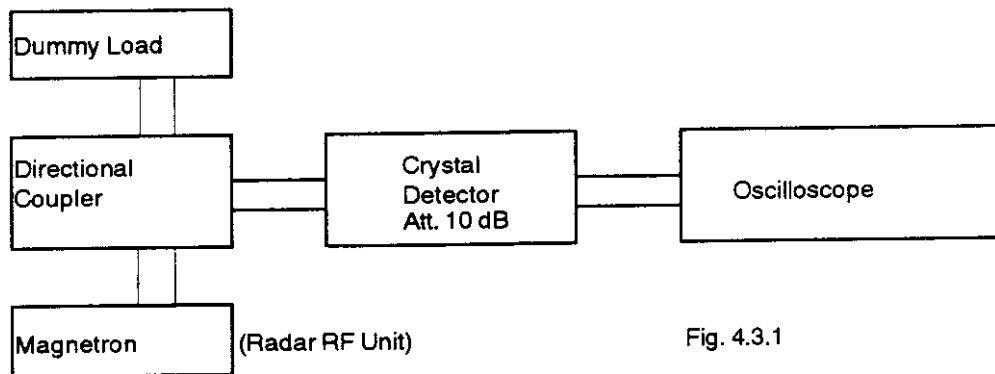

Fig. 4.3.1

4.3.2 Measuring Equipment List:

See ATTACHMENT 4 [LIST OF TEST/MEASURING EQUIPMENT].

4.3.3 Measured Data:

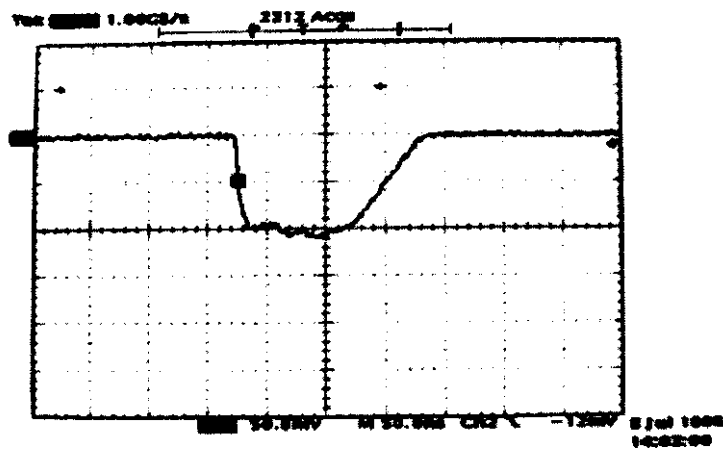

Fig. 4.3.2 Short Pulse (0.25 nm Range) Scale: 50 mV/div. 50 ns/div.

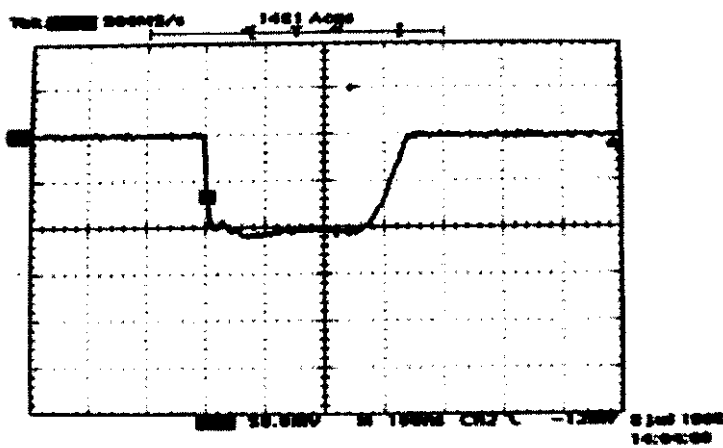

Fig. 4.3.3 Middle Pulse (2 nm Range) Scale: 50 mV/div. 100 ns/div.

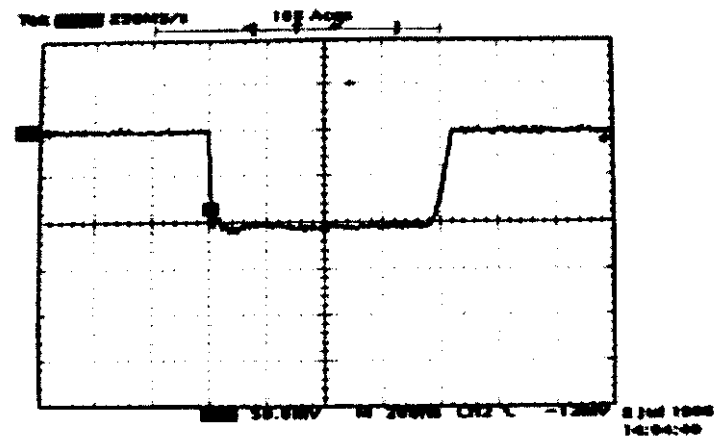

Fig. 4.3.4 Long Pulse (48 nm Range) Scale: 50 mV/div. 200 ns/div.

4.4 Radar Pulse Spectrum:

Measured by the spectrum analyzer.

(Test Equipment Setup and Measuring Equipment List are same as Clause 6.1 and 6.2.)

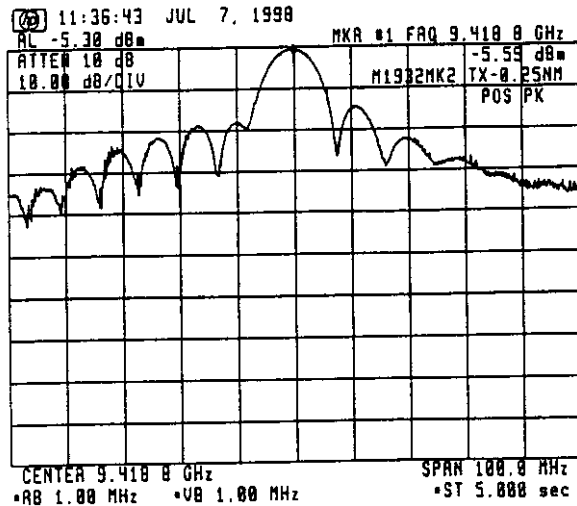

Fig. 4.4.1 Short Pulse (0.25 nm Range)

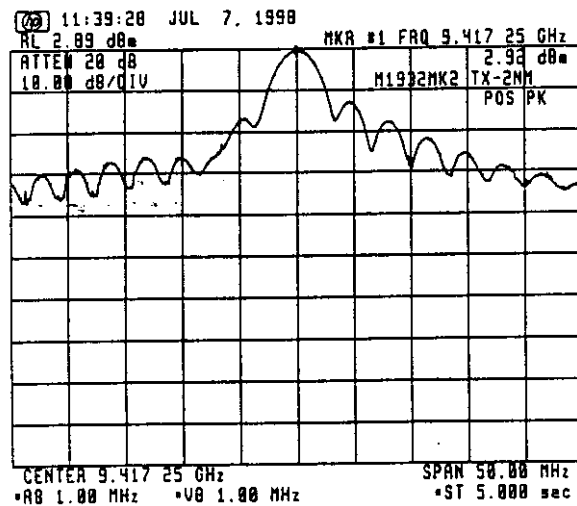

Fig. 4.4.2 Middle Pulse (2 nm Range)

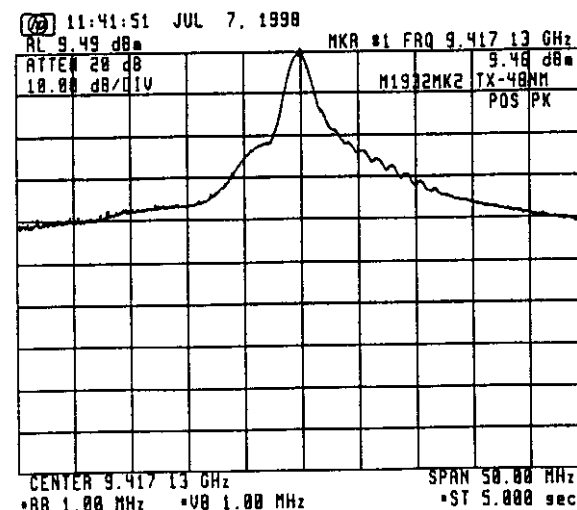

Fig. 4.4.3 Long Pulse (48 nm Range)

5 OCCUPIED BANDWIDTH (FCC Rule § 2.989)

5.1 Measuring Method

FCC rule 47 CFR 2.989 requires measurements of the occupied bandwidth which is defined in the same section as "the frequency bandwidth such that, below its lower and above its upper frequency limits, the mean powers radiated are each equal to 0.5 percent of the total mean power radiated by a given emission."

To obtain the occupied bandwidth of the radar transmitter, a special program (program list shown below) was loaded to the Hewlett-Packard spectrum analyzer and run by entering the HP-provided POWER BANDWIDTH calculation command [PWRBW].

The result was automatically displayed on the screen on the spectrum analyzer as:

POWER_BW=----- MHz

```

10 ! HP_71000 DOWNLOAD PROGRAM
20 ASSIGN @Sa TO 718
30 CLEAR @Sa
40 CALL M_ain(@Sa)
50 LOCAL @Sa
60 END
70 !
80 SUB M_ain(@Sa)
90 M_ain: !
100 CALL Pwr_bw(@Sa)
110 CALL Limit_line(@Sa)
120 !
130 OUTPUT @Sa:"VARDEF K_ey,0;";
140 !
150 OUTPUT @Sa:"FUNCDEF D_LP,^";
160 OUTPUT @Sa:"MOV K_ey,0;";
170 !
180 Main_menu: !
190 OUTPUT @Sa:"REPEAT;";
200 OUTPUT @Sa:"READMENU K_ey;";
210 ! location: %Top----Bottom-%
220 OUTPUT @Sa:"1,%Limit line %,";
230 OUTPUT @Sa:"2,%Power bw %,";
240 OUTPUT @Sa:"14,% Exit%,";
250 !
260 OUTPUT @Sa:"IF K_ey,EQ,1;THEN:LIMIT_LINE;";
270 OUTPUT @Sa:"ELSIF K_ey,EQ,2;THEN:PWR_BW;";
280 OUTPUT @Sa:"ELSIF K_ey,EQ,14;THEN:ABORT;";
290 OUTPUT @Sa:"ENDIF;";
300 OUTPUT @Sa:"UNTIL K_ey,EQ,14;";
310 OUTPUT @Sa:"P;TS;";
320 OUTPUT @Sa:"ADORT;";
330 OUTPUT @Sa:"";
340 !
350 Define_keydef: !
360 OUTPUT @Sa:"KEYDEF 7,D_LP, %DLP TEST%;";
370 !
380 OUTPUT @Sa:"FUNCDEF D,^";
390 OUTPUT @Sa:"KEYPST;";
400 OUTPUT @Sa:"";
410 !
420 SUBEND

430 !
440 SUB Limit_line(@Sa)
450 Limit_line: !
460 OUTPUT @Sa:"CLR DSP;";
470 OUTPUT @Sa:"FUNCDEF LIMIT_LINE,^";
480 OUTPUT @Sa:"PU;PA 0,654;";
490 OUTPUT @Sa:"LINET 1;";
500 OUTPUT @Sa:"PD;PA 100,654;";
510 OUTPUT @Sa:"PU;PA 201,654;";
520 OUTPUT @Sa:"PD;PA 300,654;";
530 OUTPUT @Sa:"PU;PA 105,630;";
540 OUTPUT @Sa:"TEXT @-35dB@;";
550 OUTPUT @Sa:"PU;PA 205,720;";
560 OUTPUT @Sa:"TEXT @-25dB@;";
570 OUTPUT @Sa:"PU;PA 301,743;";
580 OUTPUT @Sa:"LINET 1;";
590 OUTPUT @Sa:"PD;PA 400,743;";
600 OUTPUT @Sa:"PU;PA 601,743;";
610 OUTPUT @Sa:"LINET 1;";
620 OUTPUT @Sa:"PD;PA 700,743;";
630 OUTPUT @Sa:"PU;PA 701,654;";
640 OUTPUT @Sa:"LINET 1;";
650 OUTPUT @Sa:"PD;PA 1000,654;HD;";
660 OUTPUT @Sa:"";
670 SUBEND
680 SUB Pwr_bw(@Sa)
690 Pwr_bw: !
700 ! Calculating Power band width
710 OUTPUT @Sa: "VARDEF P_bw,0;";
720 OUTPUT @Sa:"FUNCDEF PWR_BW,^";
730 OUTPUT @Sa:"CLRW TRA;";
740 OUTPUT @Sa:"CLR DSP;";
750 OUTPUT @Sa:"SNGLS;";
760 OUTPUT @Sa:"MXMH TRA;TS;TS;TS;";
770 OUTPUT @Sa:"MOV P_bw,PWRBW TRA,99.0;";
780 OUTPUT @Sa:"DIV P_bw,P_bw,1000000;";
790 OUTPUT @Sa:"PU;PA 10,800;HD;";
800 OUTPUT @Sa:"TEXT @POWER_BW = @;";
810 OUTPUT @Sa:"DSPLY P_bw,8,3;";
820 OUTPUT @Sa:"TEXT @ MHz @;";
830 OUTPUT @Sa:"";
840 SUBEND

```

Fig. 5.1 Program for Calculation of Occupied Bandwidth

5.2 Test Equipment Setup:

Same as Clause 6.1.

5.3 Measuring Equipment List:

Same as Clause 6.2.

5.4 Test Result:

The test result is shown below.

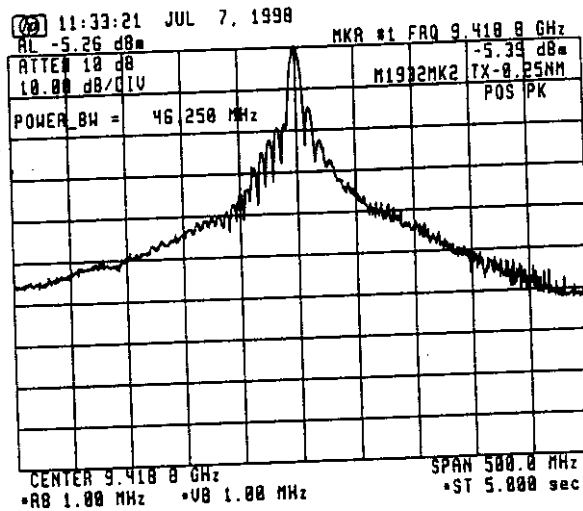

Fig. 5.2 Measurement of Occupied Bandwidth

Occupied bandwidth = 46.250 MHz

6 SPURIOUS EMISSIONS AT ANTENNA TERMINAL (FCC Rule § 2.991)

6.1 Test Equipment Setup:

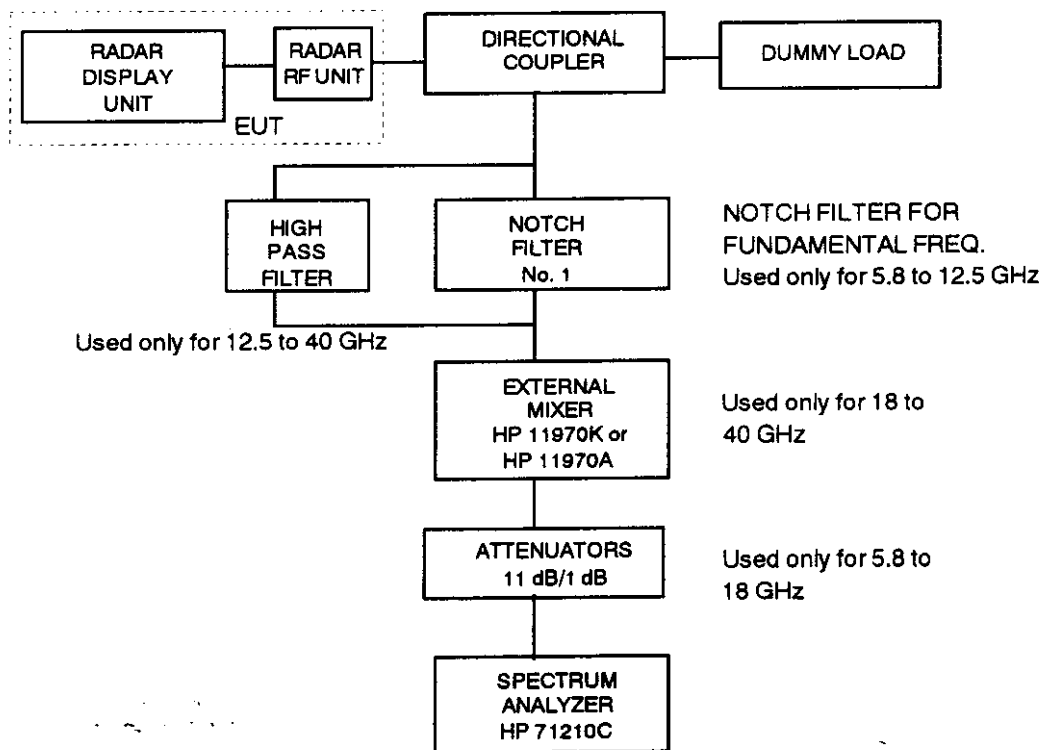

Fig. 6.1

6.2 Measuring Equipment List:

See ATTACHMENT 4 [LIST OF TEST/MEASURING EQUIPMENT].

- Note : (1) The characteristics of Notch Filter (No. 1) are described in Fig. 6.2 to Fig. 6.5.
(2) The characteristic of High Pass Filter (No. 2) is described in Fig. 6.6.

6.3 Test Conditions:

Radar Range Settings: 0.25 nm (Short)/2 nm (Middle)/48 nm (Long)

6.4 Emission Limits:

- (a) Frequency Range (FCC Rule § 2.997) : 10 kHz - 40 GHz
- (b) Emission Limits (FCC Rule § 80.211) :

Frequency removed from the assigned frequency	Frequency (Hz)	Emission attenuation (mean power ,dB)
50 - 100 % (of the authorized bandwidth)	9310 - 9360 M	At least 25
	9460 - 9510 M	
100 - 250 %	9160 - 9310 M 9510 - 9660 M	At least 35
more than 250 %	10 k - 9160 M 9660 - 40,000 M	At least 43 + 10 log 10 (mean power in watts)

- Note : (1) Assigned frequency (center frequency) = 9410 MHz
(2) Authorized bandwidth = 100 MHz

6.5 Test Results:

As shown in ATTACHMENT 1 , the spurious emissions at antenna terminal of EUT are found lower than the specified limits.

(Note: Spurious emissions for 10 kHz to 5 GHz are not found due to the antenna terminal structure. (wave guide tube)).

Characteristic of Filter No. 1 (for X-band)

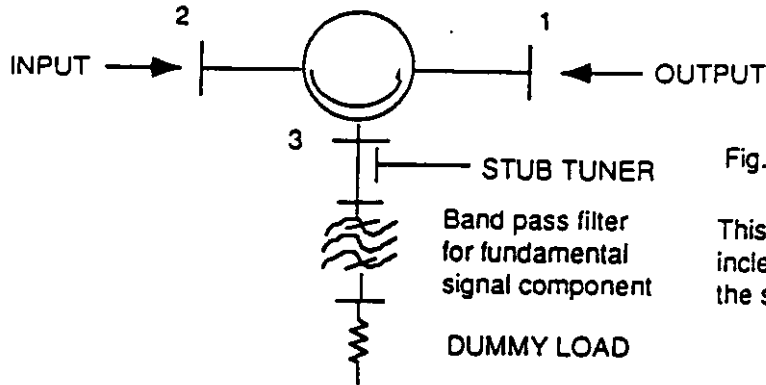

Fig. 6.2 Setup of Notch Filter No.1

This notch filter is used to increase the dynamic range of the spectrum analyzer

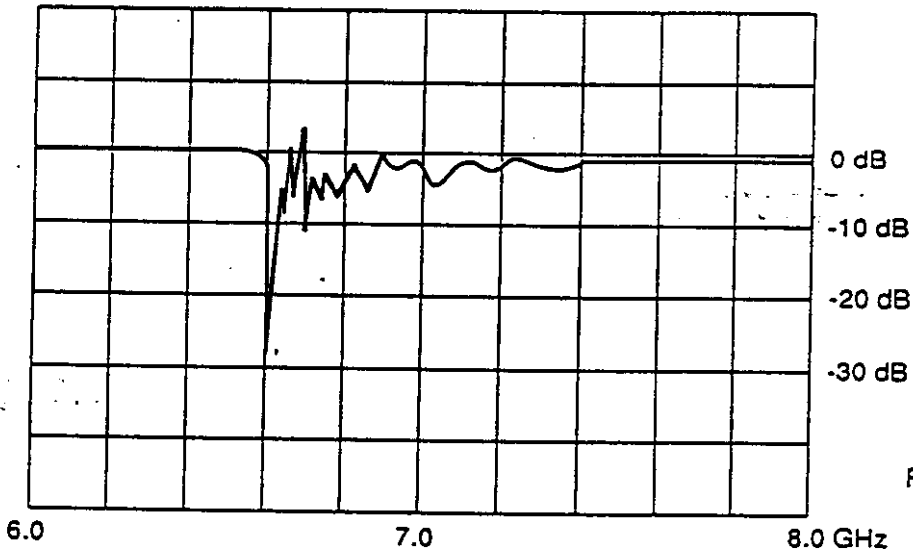

Fig. 6.3

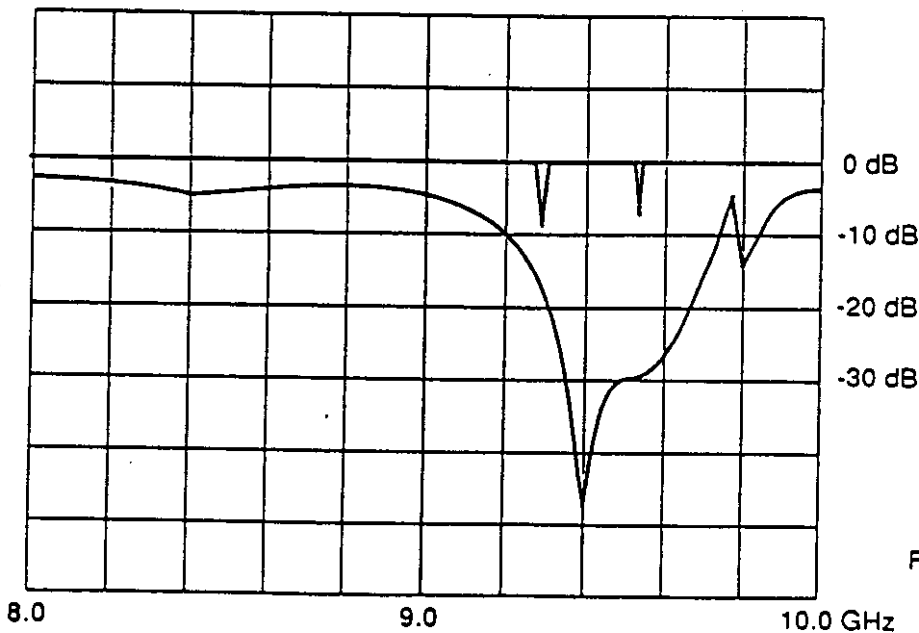

Fig. 6.4

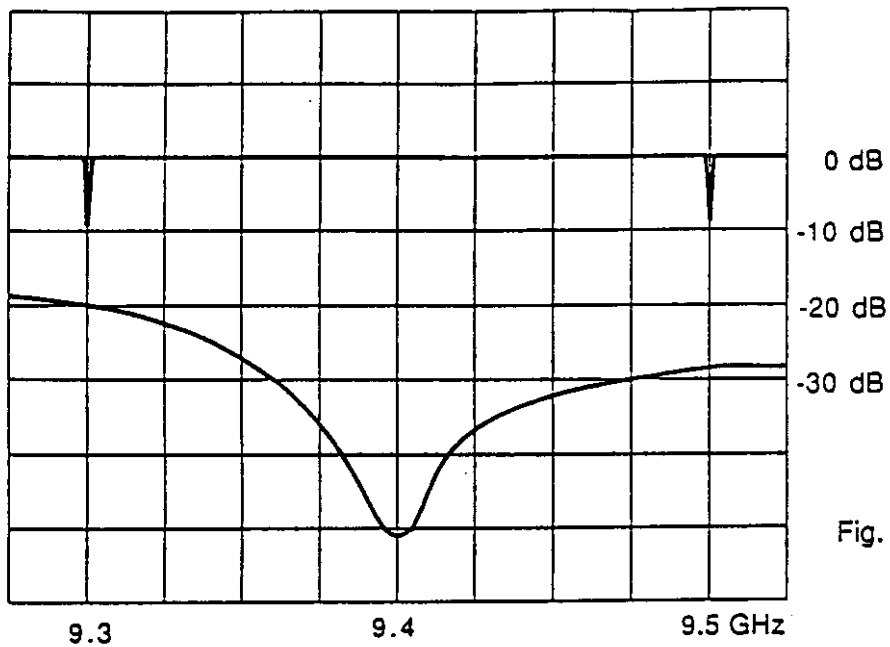
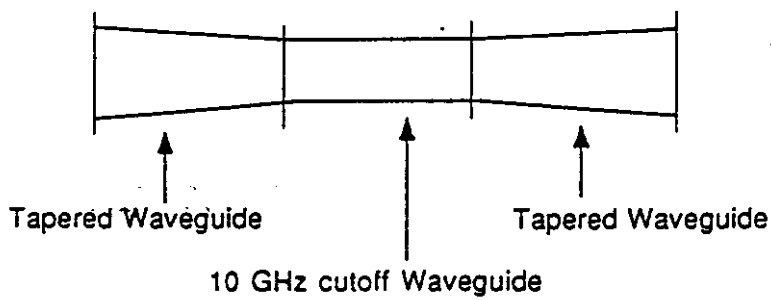

Fig. 6.5

Characteristic of Filter No. 2 (for X-band)



This filter is used to filter out the high level fundamental signal to avoid damage to the analyzer.

High Pass Filter Construction

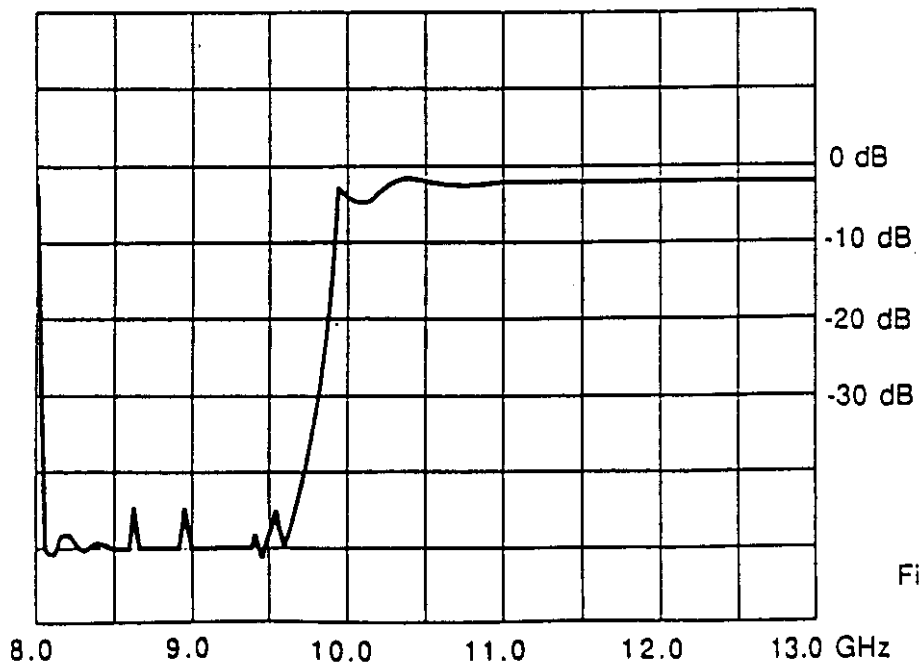

Fig.6.6

7 FIELD STRENGTH OF SPURIOUS RADIATION (FCC Rule § 2.993)

7.1 Test Site: Rooftop of 6-story building,
FURUNO ELECTRIC CO., LTD.
Ashihara-cho 9-52, Nishinomiya-city, 662-8580 Japan

7.2 Date: July, 1998

7.3 Distance between the radar set and measuring antenna: 10 m

7.4 Radar Range settings: 0.25 nm (Short)/2 nm (Middle)/48 nm (Long)

7.5 Measuring Equipment List:
See ATTACHMENT 4 [LIST OF TEST/MEASURING EQUIPMENT].

7.6 Test settings:
See Fig. 7.1 - Fig. 7.5.

7.7 Field Strength Limits:

(a) Frequency Range (FCC Rule § 2.997) : 10 kHz - 40 GHz

(b) Emission Limits (FCC Rule § 80.211) :

Frequency removed from the assigned frequency	Frequency (Hz)	Emission attenuation (mean power ,dB)
50 - 100 % (of the authorized bandwidth)	9310 - 9360 M 9460 - 9510 M	At least 25
100 - 250 %	9160 - 9310 M 9510 - 9660 M	At least 35
more than 250 %	10 k - 9160 M 9660 - 40,000 M	At least 43 + 10 log 10 (mean power in watts)

Note : (1) Assigned frequency (center frequency) = 9410 MHz

(2) Authorized bandwidth = 100 MHz

7.8 Test Results:

As shown in ATTACHMENT 2 , the field strengths of spurious radiation generated by EUT are found lower than the specified limits.

8 FREQUENCY STABILITY (FCC Rule § 2.995)

8.1 Setup for Measurement

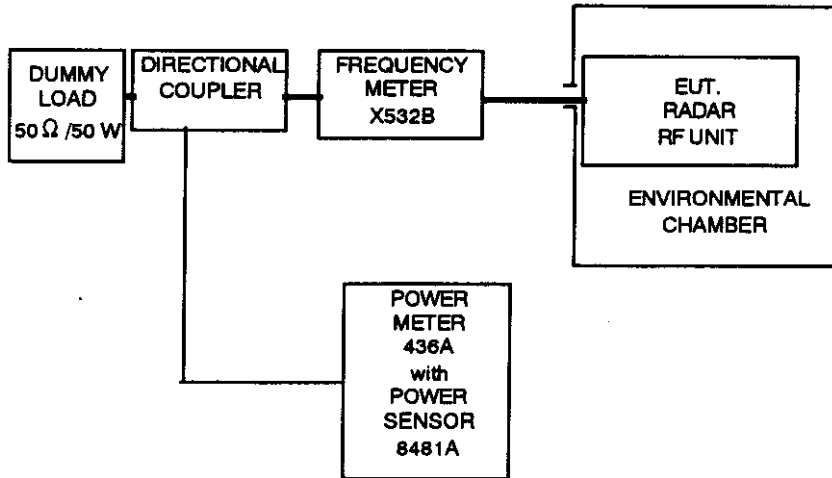

Fig. 8.1

8.2 Test Conditions:

- 1) Radar Range settings : 0.25 nm (Short)/2 nm (Middle)/48 nm (Long)
- 2) Ambient Temperature settings: - 20 to + 50 °C (10 °C step)
- 3) Power Supply Voltage settings: 85 /115 % of nominal voltage (20.4 to 27.6 VDC)

8.3 Measuring Equipment List:

See ATTACHMENT 4 [LIST OF TEST/MEASURING EQUIPMENT].

8 FREQUENCY STABILITY (FCC Rule § 2.995)

8.1 Setup for Measurement

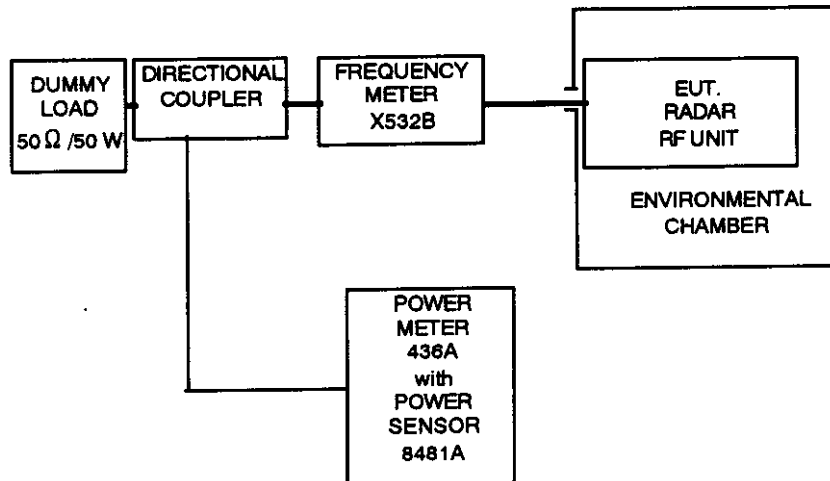

Fig. 8.1

8.2 Test Conditions:

- 1) Radar Range settings : 0.25 nm (Short)/2 nm (Middle)/48 nm (Long)
- 2) Ambient Temperature settings: - 20 to + 50 °C (10 °C step)
- 3) Power Supply Voltage settings: 85 /115 % of nominal voltage (20.4 to 27.6 VDC)

8.3 Measuring Equipment List:

See ATTACHMENT 4 [LIST OF TEST/MEASURING EQUIPMENT].



8.4 Frequency Tolerance Limits:

"The frequency at which maximum emission occurs must be within the authorized bandwidth and must not be closer than 1.5/T MHz to the upper and lower limits of the authorized band width, where "T" is the pulse duration in microseconds. " (FCC Rule § 80.209)

1) Center frequency (f_0): 9410 MHz

2) Authorized bandwidth ($f(\text{AUBW})$): 100 MHz

"Upper limit frequency of the authorized band", $f(\text{UAUBW}) = f_0 + f(\text{AUBW})/2 = 9460 \text{ MHz}$

"Lower limit frequency of the authorized band", $f(\text{LAUBW}) = f_0 - f(\text{AUBW})/2 = 9360 \text{ MHz}$

3) Assignable frequency bandwidth : 200 MHz (between 9300 MHz and 9500 MHz)
(FCC Rule § 80.375 (d)-(1))

"Upper limit frequency of the assignable band", $f(\text{UASB}) = 9500 \text{ MHz}$

"Lower limit frequency of the assignable band", $f(\text{LASB}) = 9300 \text{ MHz}$

4) Guard Band ($f(1.5/T)$) :

Pulse Type	Short	Middle	Long
Range Scale (nm)	0.25	2	48
Pulse length ($\mu \text{ sec}$)	0.08	0.30	0.80
Guard Band $f(1.5/T)$ (MHz)	18.75	5.00	1.88

8.5 Test Results:

Shown on Fig. 8.2.

(1) "Upper Tolerance Frequency measured (at - 20 °C)", $f(\text{U}) = 9420.6 \text{ MHz}$

(2) "Lower Tolerance Frequency measured (at + 50 °C)", $f(\text{L}) = 9415.0 \text{ MHz}$

(3)-(a)

$f(\text{U}) + \text{max. } f(1.5/T) = 9439.4 \text{ MHz} < f(\text{UAUBW}) = 9460 \text{ MHz} < f(\text{UASB}) = 9500 \text{ MHz}$

(3)-(b)

$f(\text{L}) - \text{max. } f(1.5/T) = 9396.3 \text{ MHz} > f(\text{LAUBW}) = 9360 \text{ MHz} > f(\text{LASB}) = 9300 \text{ MHz}$

So, both are found within the specified limits.

FREQUENCY STABILITY WITH VARIATION OF PRIMARY SUPPLY VOLTAGE:

The built-in voltage regulator allows no frequency variation against variations of $\pm 15\%$ of nominal power supply voltage (20.4 to 27.6 VDC for nominal 24 VDC).

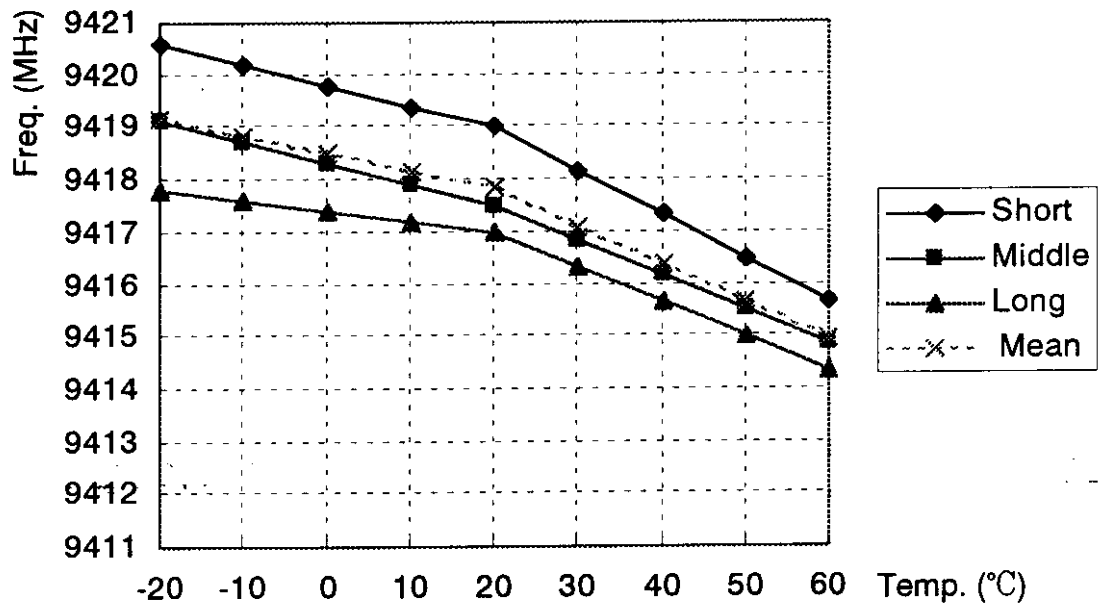

Fig. 8.2 Frequency Stability with Variation of Ambient Temperature

9 SUPPRESSION OF INTERFERENCE ABOARD SHIPS

(FCC Rule § 80.217)

9.1 Measuring Antenna Characteristics at Representative Frequencies:

Whip antennas are used to determine the level of interference caused by the radar to shipboard receivers. These antennas have the following characteristics (refer to impedance charts attached):

Length	Test Frequency (Hz)	Impedance (Ω)	θ	R (Ω)	C or L
6 m	500.5 k	1 k	-90°	0	80 pF
6 m	1.992 M	1.25 k	-86°	87.2	64 pF
6 m	10.00204 M	158		109	140 pF
4 m	27.5 M	95		83.5	128 pF
5/8 λ	150 M	116.5		105.5	52.5 nH
1/4 λ	450 M	70.5		34.5	5.68 pF

9.2 Test Site: Rooftop of 6-story building,
Furuno Electric Company, Ltd.
Ashihara-cho 9-52, Nishinomiya-city, 662-8580 JAPAN

9.3 Measuring Instruments:

- (1) RF Vector Impedance Meter, HP 4815A
- (2) Spectrum Analyzer, ADVANTEST TR4172
- (3) Spectrum Analyzer, HP 8566B
- (4) Antennas,
for 14 k - 10 MHz, 6 m whip
for 10 - 30 MHz, 4 m whip
for 30 - 300 MHz, VHF whip
for 300 - 1000 MHz, UHF whip

9.4 Test Results:

Interference levels to the respective antenna were measured at 2 m from the radar which was put in OFF, STANDBY, TRANSMIT conditions., and found within the specified limits.

9.4.1 Harmful Interference to Receiver (FCC Rule § 80.217 (a))

Limits: for 14 - 490 kHz, 5 $\mu\text{V/m}$
for 490 kHz - 1 GHz, 1 $\mu\text{V/m}$

Results: There is no spurious component which is deemed harmful interference. (Test data are shown in ATTACHMENT 3)

9.4.2 Electromagnetic Field (FCC Rule § 80.217 (b) - 1)

Limits: for below 30 MHz, 0.1 $\mu\text{V/m}$ at 1 nm (-20 dBmV/m)
for 30 to 100 MHz, 0.3 $\mu\text{V/m}$ at 1 nm (-10.5 dBmV/m)
for 100 to 300 MHz, 1.0 $\mu\text{V/m}$ at 1 nm (0 dBmV/m)
for over 300 MHz, 3.0 $\mu\text{V/m}$ at 1 nm (9.5 dBmV/m)

Results: Interference was measured with the antenna located 2 m from the radar and converted to levels at 1 nm. There is no spurious component exceeding the limits.
(Test data are shown in ATTACHMENT 3)

9.4.3 Power Input to an Artificial Antenna (FCC Rule § 80.217 (b) - 2)

Limits: for below 30 MHz, 400 μW
for 30 to 100 MHz, 4,000 μW
for 100 to 300 MHz, 40,000 μW
for over 300 MHz, 400,000 μW

Results: There is no spurious component exceeding the limits.
(Test data are shown in ATTACHMENT 3)

MEASUREMENT OF IMPEDANCE OF TEST ANTENNAS

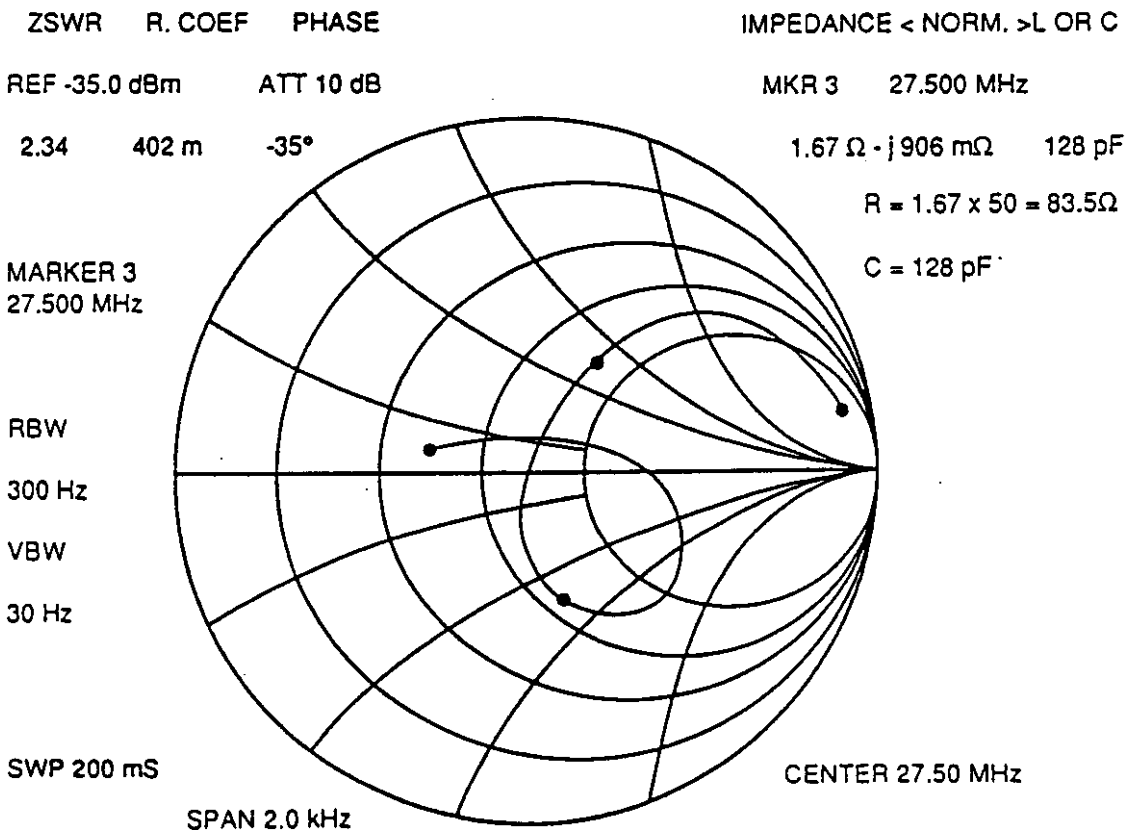
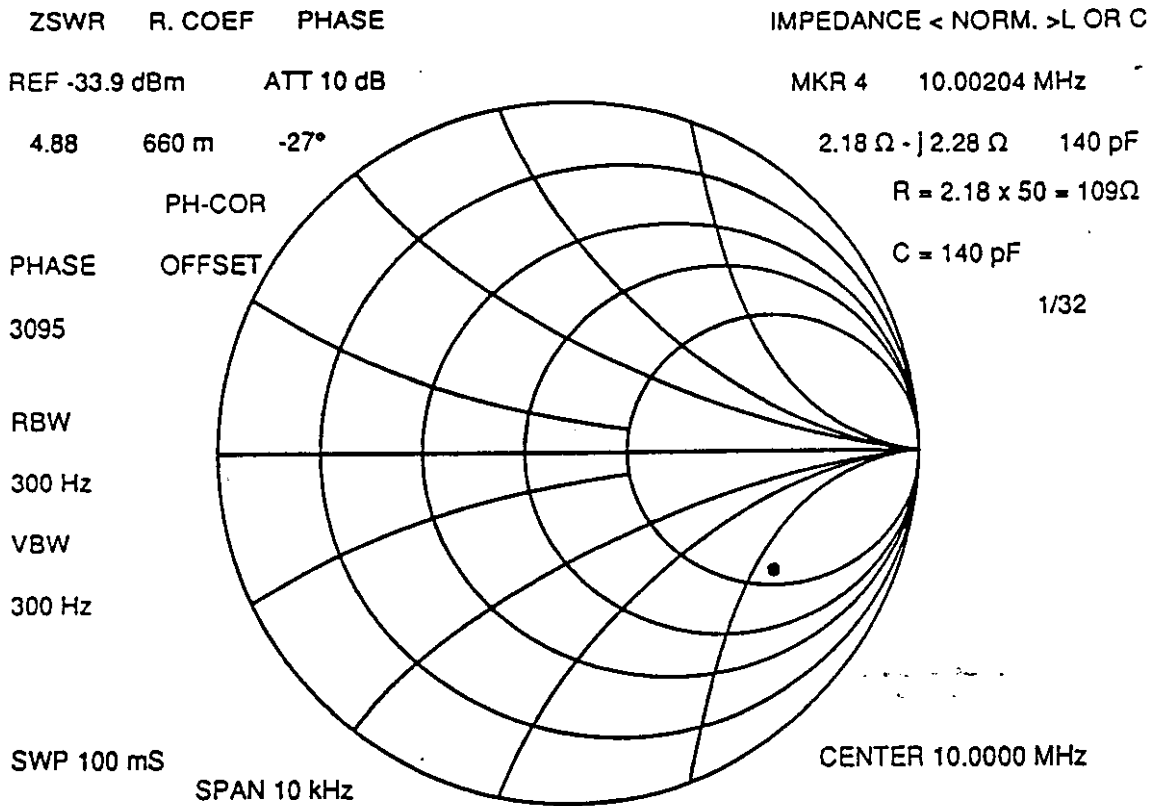

MEASUREMENT OF IMPEDANCE OF TEST ANTENNAS

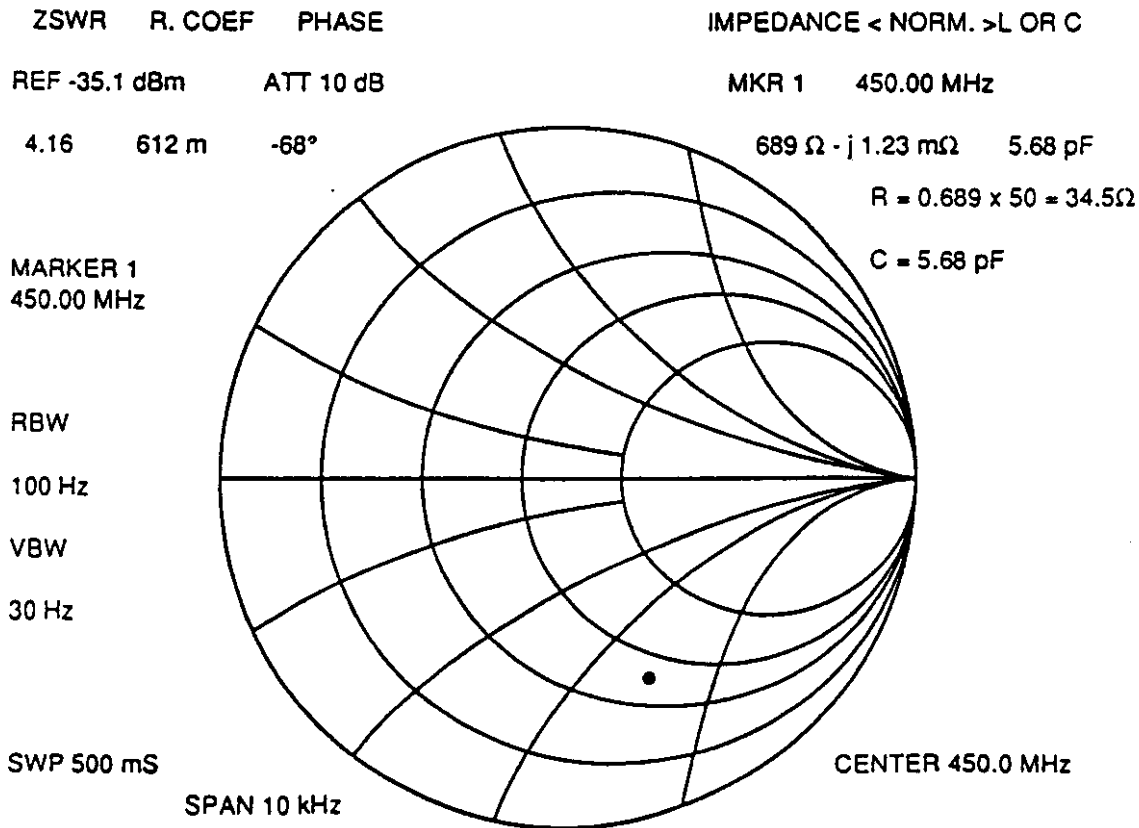
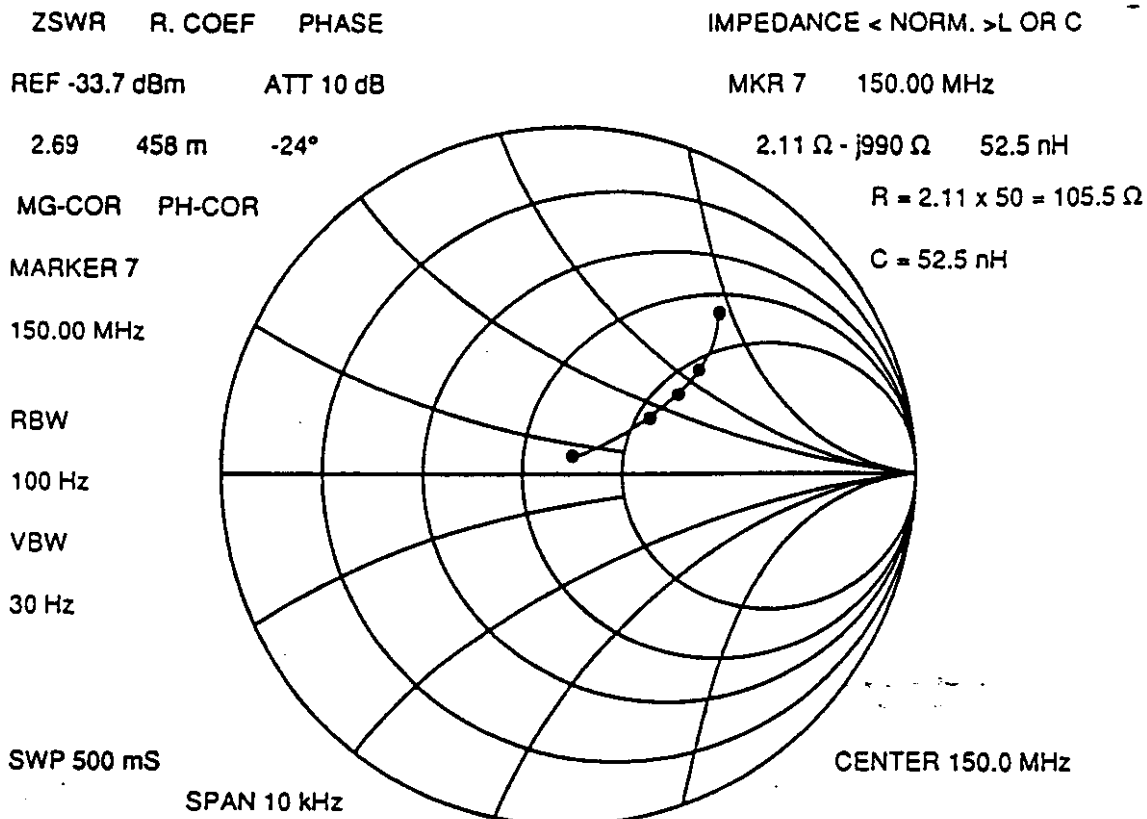

Pub. No. : TI-1697

Date : July, 1998

11 TECHNICAL DESCRIPTION OF EQUIPMENT (FCC Rules § 2.983)

11.1 Function of Each Semiconductor or Active Device (FCC Rule § 2.983 (d)(6))

ANTENNA UNIT

TRANSCEIVER MODULE (RTR-064)

Modulator PCB_03P9235

CR801:	Rectifier
CR802:	Rectifier
CR803:	Rectifier
CR804:	Transient Suppression
CR805:	Rectifier
CR806:	Detector (Magnetron Current)
CR807:	Pulse width Select
CR809:	Reverse Voltage Protection
L801:	Noise Reject
L802:	Noise Reject
L804:	Noise Reject
Q801:	45 kHz PWM Output MOS FET
Q802:	Pulse Amplifier
Q803:	Pulse Amplifier
Q804:	Pulse width Select
Q805:	Pulse Amplifier
Q806:	Pulse Amplifier
Q807:	IF Bandwidth Select
Q808:	Pulse Amplifier
Q809:	Pulse Amplifier
Q810:	Protective Circuit Monitor
Q811:	Switching
Q812:	Switching
T801:	Transformer
T802:	Pulse Transformer
U802:	Voltage Detector
U803:	Voltage Detector
U804:	Voltage Detector

Pub. No. : TI-1697

Date : July, 1998

U805: Pulse Forming Network
U806: 45 kHz PWM Inverter

Chassis Mounted Parts

HY801: 3 Ports Circulator
U801: MIC Frequency Converter with Limiter
V801: Magnetron

IF Amplifier PCB IF-9214

CR1 to CR6: Switching
CR8: Level Shifter
CR10: DC Restoring
CR11: Over Voltage Protection
CR12: Reverse Voltage Protection
CR13: Reverse Voltage Protection
CR14: Over Voltage Protection
CR15: Over Voltage Protection

CR16: Over Voltage Protection
Q1 to Q4: Video Amplifier
Q5: Inverter
Q6: DC Amplifier
Q7: Switching
Q8: I.F. Amplifier in Cascade Connection
Q9: I.F. Amplifier in Cascade Connection
Q10: Bias Setting
Q11: Detector
Q12: Current Buffer
Q13: Tuning Indication Amplifier
Q14: Tuning Indication Amplifier
Q15: Switching
Q16: MBS Pulse Amplifier
Q17: Tuning Gate Amplifier
U1 to U4: I.F. Amplifier

Pub. No. : TI-1697

Date : July, 1998

U5: Inverter
U6 to U9: DC Regulator

Motor Soft Starter PCB 03P9249

CR1: Reverse Voltage Protection
CR2: C703 discharger
CR3: Level Shifter
CR4: Soft starter switch
CR5: Reverse Voltage Protection
Q1: Buffer for bearing pulse
Q2: Buffer for bearing pulse
Q3: Trigger switch for CR4

Pub. No. : TI-1697

Date : July, 1998

11.2 Description of the circuits employed for suppression of spurious radiation, for limiting or shaping the control pulse, and for limiting or controlling power

(FCC Rule § 2.983 (d) (11))

ANTENNA UNIT

TRANSCEIVER MODULE (RTR-064)

Modulator PCB 03P9235

The primary function of the modulator is to produce narrow high tension pulses to drive the magnetron. To produce such pulses, the modulator board incorporates a modulator trigger circuit, a modulating pulse generator and a booster pulse transformer.

The modulator trigger circuit is composed of U805 and associated components. It generates pulses that fire modulator FET Q805, Q806. Normally, the circuit is stable with U805 off. The pulse to fire the modulator FET is produced when U805 turns on upon receiving the TX trigger pulse from the display unit. When U805 turns on at the positive-going edge of the TX trigger pulse, it produces a narrow pulse. This narrow pulse is boosted by pulse transformer T802 by the ratio 1:21. The resultant pulse, its level being 4.5 kV, is provided to limit the magnetron current.

C820 decouples the pulse energy that is liable to occur across the magnetron heater when T802's secondary windings are unbalanced or the load is asymmetric.

Also incorporated in the modulator board are the TX HV circuit and magnetron heater power supply circuit. The TX HV circuit provides a high tension of about 330 V to the pulse forming network through CR802, CR805. A DC voltage of 7.6 V is supplied to the magnetron heater through CR801.

Duplexer and Frequency Converter

The microwave energy produced by the magnetron enters the circulator from port 2. It is fed to port 3 with a negligible loss of energy; port 1 at this time is isolated. In the same manner, the received signal entering into port 3 is transferred to port 1, isolating port 2. This operation of the circulator protects the receiver during transmission and minimizes the loss of the received signal. Thus, the circulator allows a single antenna radiator to be

used for transmission and reception of radar signals.

A diode limiter, made up of a pair of PIN diodes, is incorporated in the first stage of the MIC (microwave IC, U801). It is a passive switching device which allows the low-level RF signal to pass through and prohibits relatively strong microwave energy, such as the leak from the magnetron. It also protects the sensitive amplifier from pulses received direct from other radars operating in the proximity.

When a low-level signal is received, the PIN diodes remain in the cutoff state, and the limiter's input impedance matches the characteristic impedance of the receiver allowing the signal to be delivered to the frequency converter of U801. When strong microwave energy is received, the PIN diodes are put in the conductive state (or short-circuited) causing the input energy to be attenuated. The strong input is further reduced to about 150 mW by the varacter diode.

The MIC converts 9 GHz RF signal into an intermediate frequency of 60 MHz. It is achieved by mixing the received signal with the local oscillator signal in the frequency converter of the MIC. The built-in local oscillator oscillates at a frequency 60 MHz higher than the magnetron frequency of 9410 MHz.

IF Amplifier IF9214

The IF signal of 60 MHz coming from the MIC is amplified and converted into a video signal, which is delivered to the display unit.

The IF amplifier is composed of five major circuits; Logarithmic Amplifier (U1/U2,U3/U4), Video Amplifier(Q1/Q2/Q3/Q4), Bandwidth Selector (Q5/Q6, CR1 to CR6), Tuning Indicator Circuit (Q8 to Q14) and Main Bang Suppression Circuit (U5, Q15/Q16/Q17, CR11 to CR15)

The IF signal from the MIC("IF"TERMINAL) is applied to the bandwidth selector.

The IF amplifier operates in narrow or wide bandwidth mode depending on the setting of the RANGE switch and TX touchpad. For short and middle ranges, a wide bandwidth (25MHz) is selected, since the levels at the base of Q5 and the collector of Q6 go high,

thus CR2, CR4, CR5 and CR6 are conductive and CR1/CR3 are cut off, causing the signal to pass through CR5/CR6. On the contrary, CR2, CR4, CR5 and CR6 are cut off and CR1/CR3 are conductive, which causes the signal to pass through C5/C6, selecting a narrow bandwidth (5MHz) on long ranges.

The signal through the bandwidth selector is coupled to the logarithmic amplifier and amplified and detected by U1/U2/U3. The detected signals are fed to Q1/Q2 to be amplified further, and then sent to the display unit via buffer Q3/Q4.

The other IF signal from the MIC ("IF TUN" TERMINAL) of 60 MHz is amplified by U4, Q8/Q9 and detected by Q10/Q11. Then the detected signal (Tuning Indicator Signal) is sent to the display unit via Q13 to Q14.

On the other hand, U4 is additional amplifier circuits to make the dynamic range of the IF signal wider, causing the discrimination of the target echoes to get better. The attenuated IF signal from the MIC ("IF TUN" TERMINAL) is fed to U4. Therefore, U4 amplifies even a strong signal which may be saturated in U1/U2/U3 and sent to logarithmic amplifier U4. This signal is added to the saturated signal in U1/U2/U3, causing the saturation level of the IF signal to become high.

The purpose of main bang suppression circuit is to minimize transmission leakage near the center spot on the screen.

When the Magnetron Current pulse generated in Modulator PCB 03P9235 is fed to the inverter U5, it produces a rectangular pulse which is controlled by Q6. This pulse is fed to "MBS" TERMINAL of the MIC through Q15/CR12 as a main bang suppression waveform, then IF Amplifier incorporated in the MIC turns off during transmission to eliminate direct reception of the strong TX energy (main bang).

Pub. No. : TI-1697

Date : July, 1998

12 OPERATOR'S MANUAL INCL. CIRCUIT DIAGRAMS (FCC Rule § 2.983)

(See separate covers)

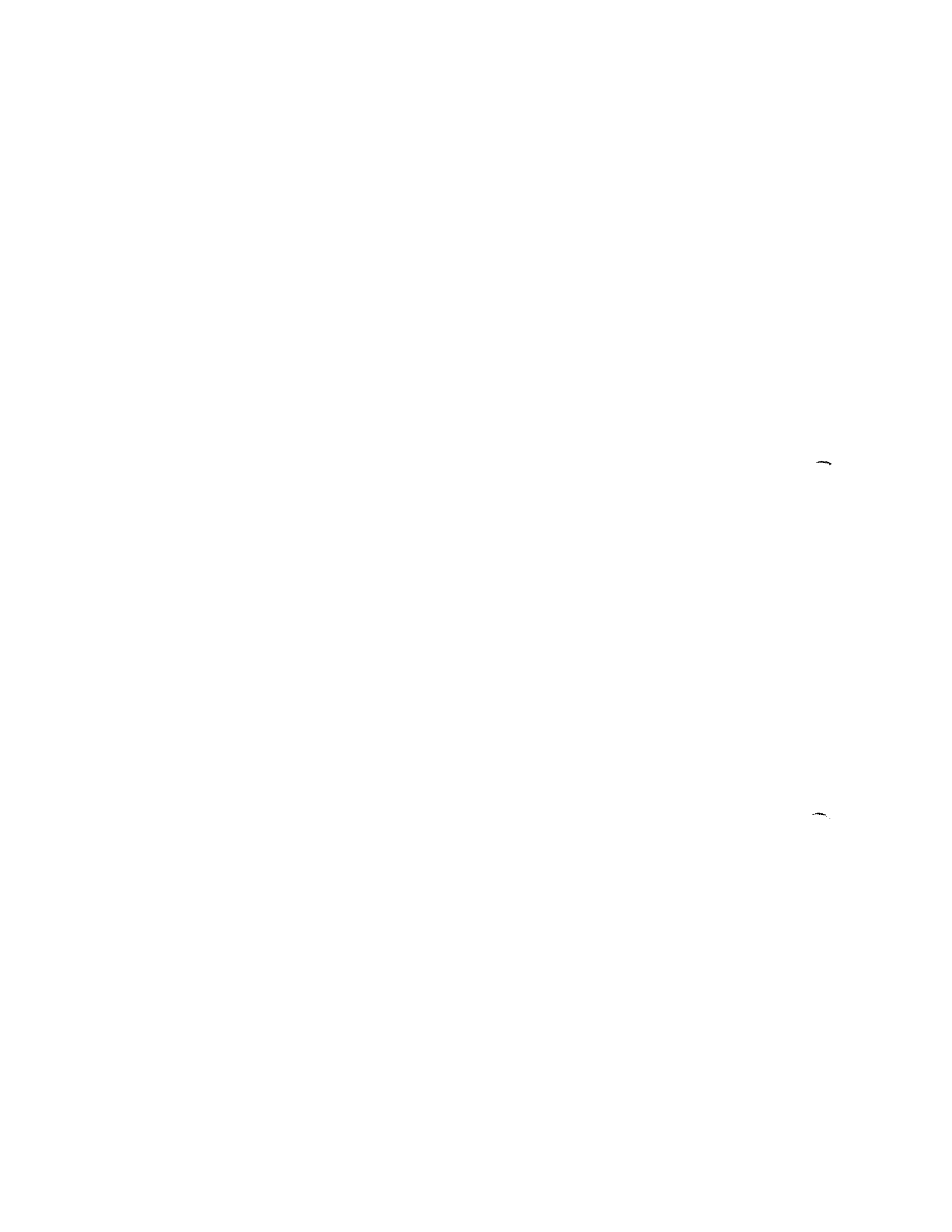

ATTACHMENT 1

[TEST DATA FOR 6_SPURIOUS EMISSIONS AT ANTENNA TERMINALS]

1. Spurious emissions for 0.25 nm Range:

Ref. level: -5.05 dBm

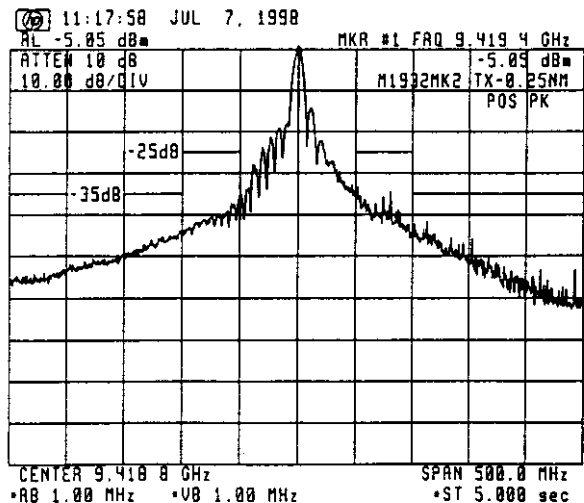

Emission limitations:

- (a) 25 dB for 50 to 100 % of the authorized BW (100 MHz)
- (b) 35 dB for 100 to 250 % of the authorized BW (100 MHz)

Fig. 1.1 Without Filter

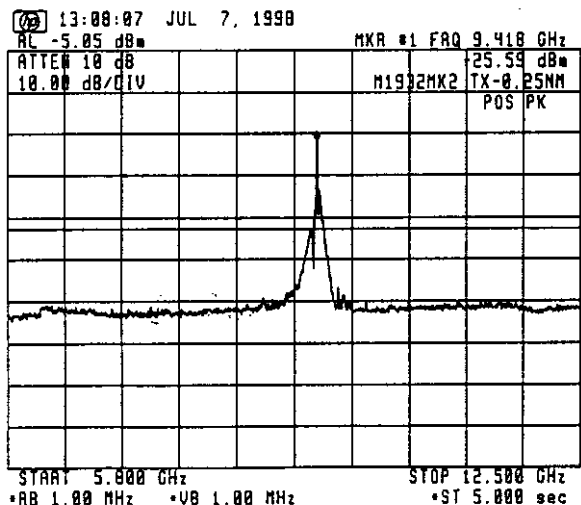

Emission limitations:

- (c) $43 + 10 \log P_m = 42.61$ dB for more than 250 % of the authorized BW (100 MHz)

Fig. 1.2 With Filter No.1

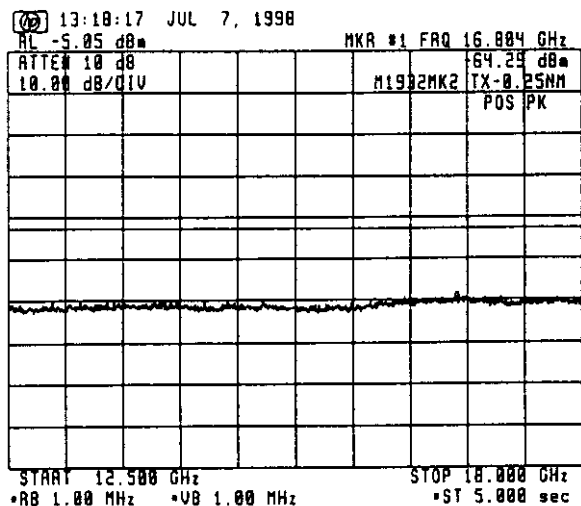

Emission limitations:

- (c) $43 + 10 \log P_m = 42.61$ dB for more than 250 % of the authorized BW (100 MHz)

Fig. 1.3 With Filter No. 2

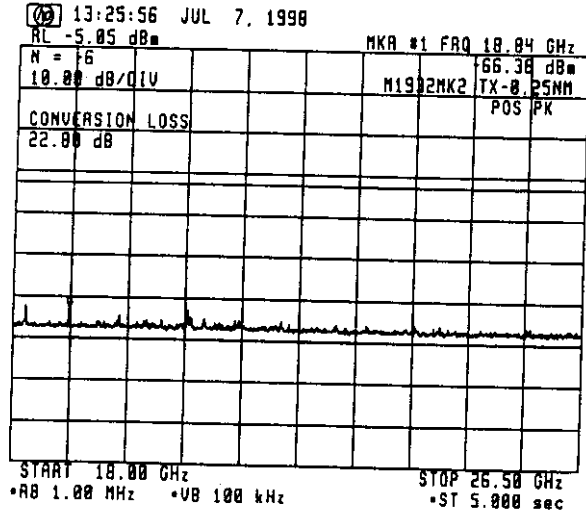

Emission limitations:

- ← (c) $43 + 10 \log P_m = 42.61 \text{ dB}$
 for more than 250 % of
 the authorized BW (100 MHz)

Fig. 1.4 With Filter No. 2

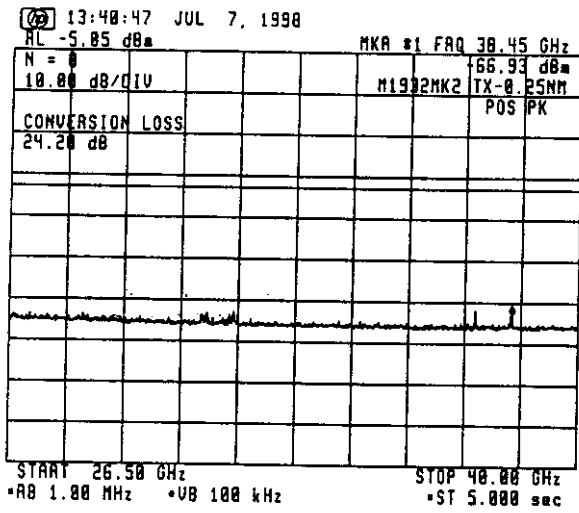

Emission limitations:

- ← (c) $43 + 10 \log P_m = 42.61 \text{ dB}$
 for more than 250 % of
 the authorized BW (100 MHz)

Fig. 1.5 With Filter No. 2

2. Spurious emissions for 2 nm Range:

Ref. level: 3.01 dBm

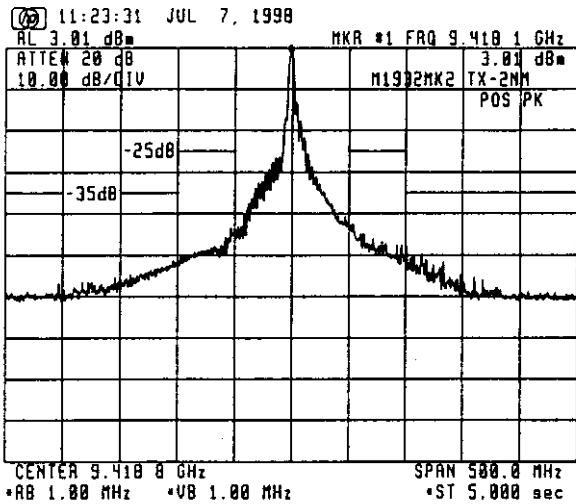

Emission limitations:

- (a) 25 dB for 50 to 100 % of the authorized BW (100 MHz)
- (b) 35 dB for 100 to 250 % of the authorized BW (100 MHz)

Fig. 2.1 Without Filter

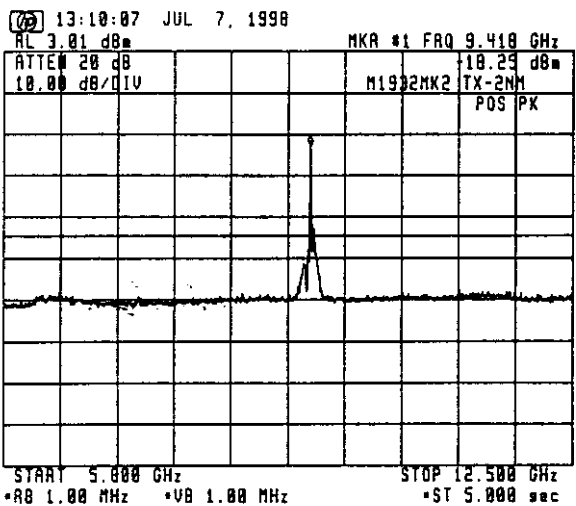

Emission limitations:

- (c) $43 + 10 \log P_m = 44.37 \text{ dB}$ for more than 250 % of the authorized BW (100 MHz)

Fig. 2.2 With Filter No.1

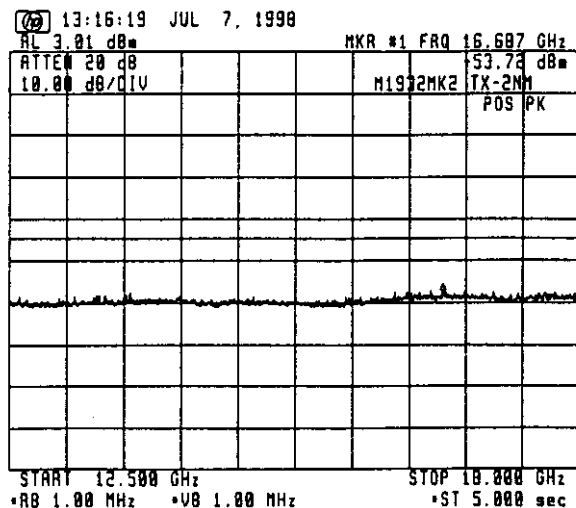

Emission limitations:

- (c) $43 + 10 \log P_m = 44.37 \text{ dB}$ for more than 250 % of the authorized BW (100 MHz)

Fig. 2.3 With Filter No. 2

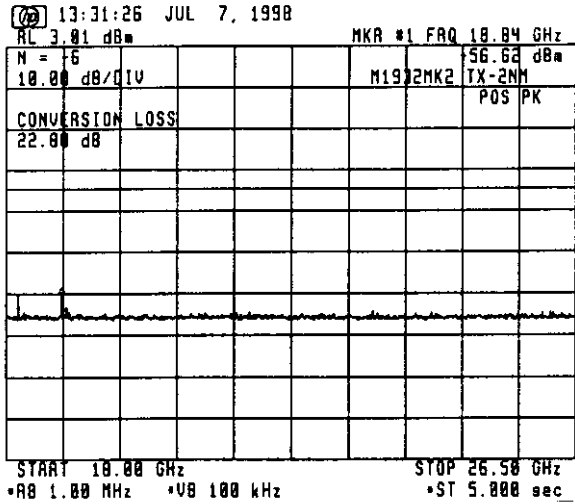

Emission limitations:

- (c) $43 + 10 \log P_m = 44.37 \text{ dB}$
 for more than 250 % of
 the authorized BW (100 MHz)

Fig. 2.4 With Filter No. 2

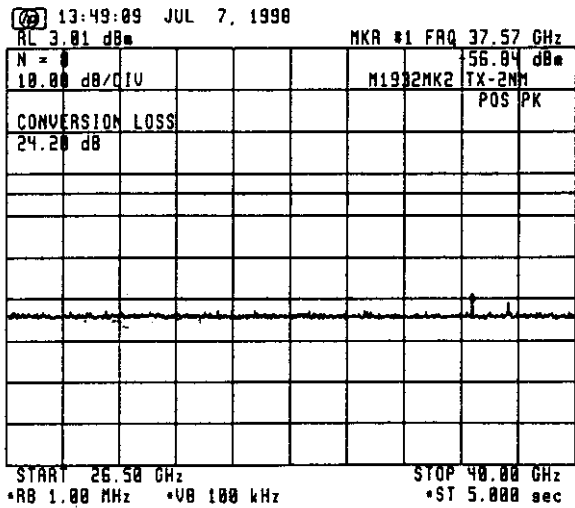

Emission limitations:

- (c) $43 + 10 \log P_m = 44.37 \text{ dB}$
 for more than 250 % of
 the authorized BW (100 MHz)

Fig. 2.5 With Filter No. 2

3. Spurious emissions for 48 nm Range:

Ref. level: 9.8 dBm

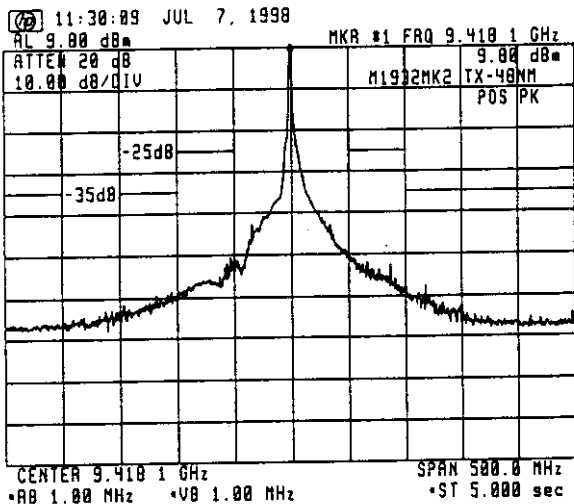

Emission limitations:

- (a) 25 dB for 50 to 100 % of the authorized BW (100 MHz)
- (b) 35 dB for 100 to 250 % of the authorized BW (100 MHz)

Fig. 3.1 Without Filter

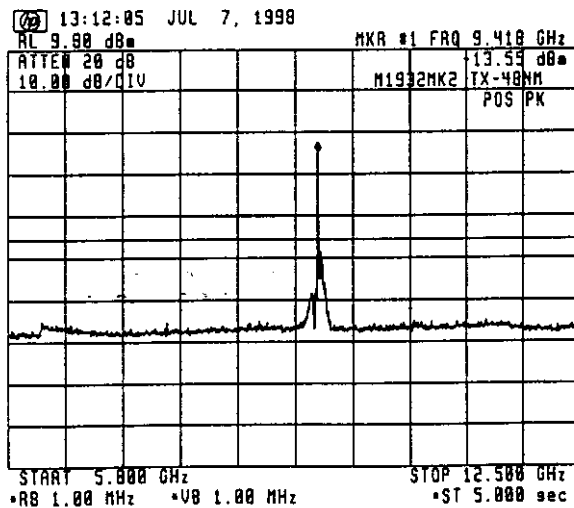

Emission limitations:

- (c) $43 + 10 \log P_m = 45.33 \text{ dB}$ for more than 250 % of the authorized BW (100 MHz)

Fig. 3.2 With Filter No.1

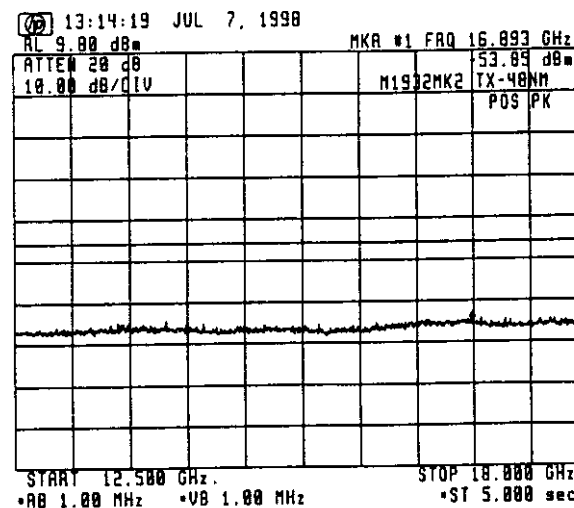

Emission limitations:

- (c) $43 + 10 \log P_m = 45.33 \text{ dB}$ for more than 250 % of the authorized BW (100 MHz)

Fig. 3.3 With Filter No. 2

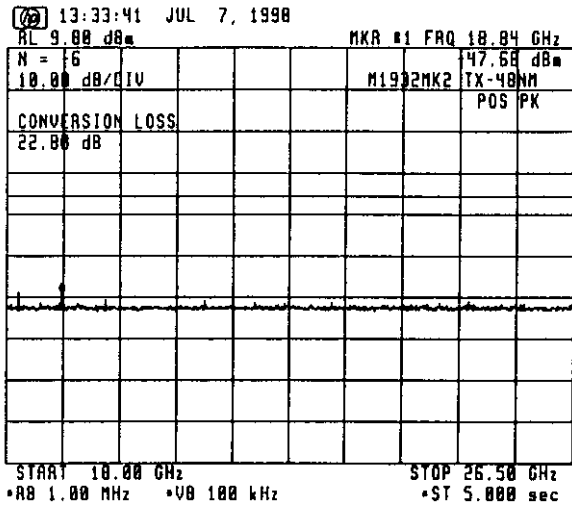

Emission limitations:

- ← (c) $43 + 10 \log P_m = 45.33 \text{ dB}$
 for more than 250 % of
 the authorized BW (100 MHz)

Fig. 3.4 With Filter No. 2

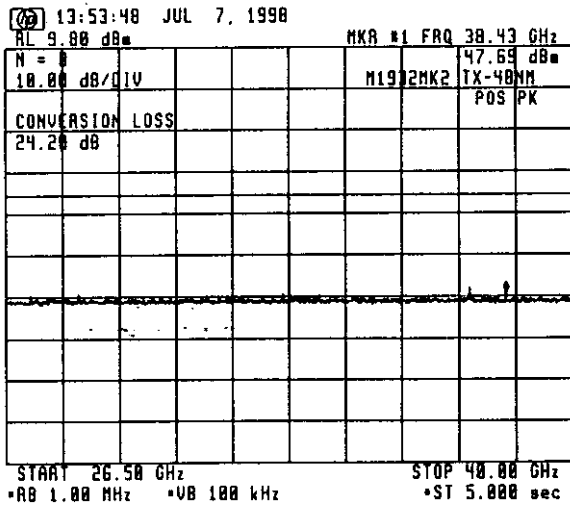

Emission limitations:

- ← (c) $43 + 10 \log P_m = 45.33 \text{ dB}$
 for more than 250 % of
 the authorized BW (100 MHz)

Fig. 3.5 With Filter No. 2

ATTACHMENT 2

[TEST DATA FOR 7. FIELD STRENGTH OF SPOURIOUS RADIATION]

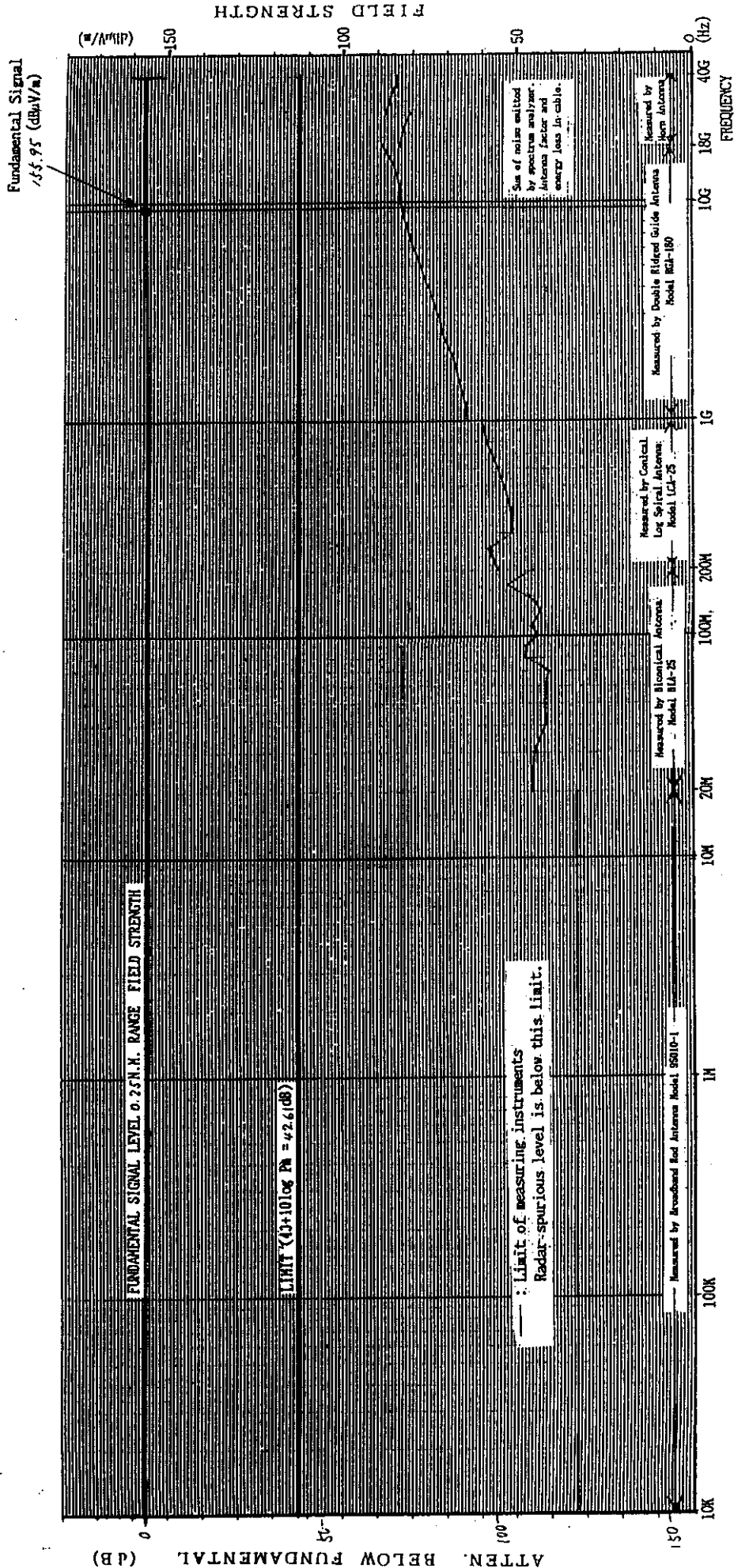

Graph 7-1 Field strength of spurious radiation measured with pick-up antenna (0.25 nm range)
 (Short Pulse)

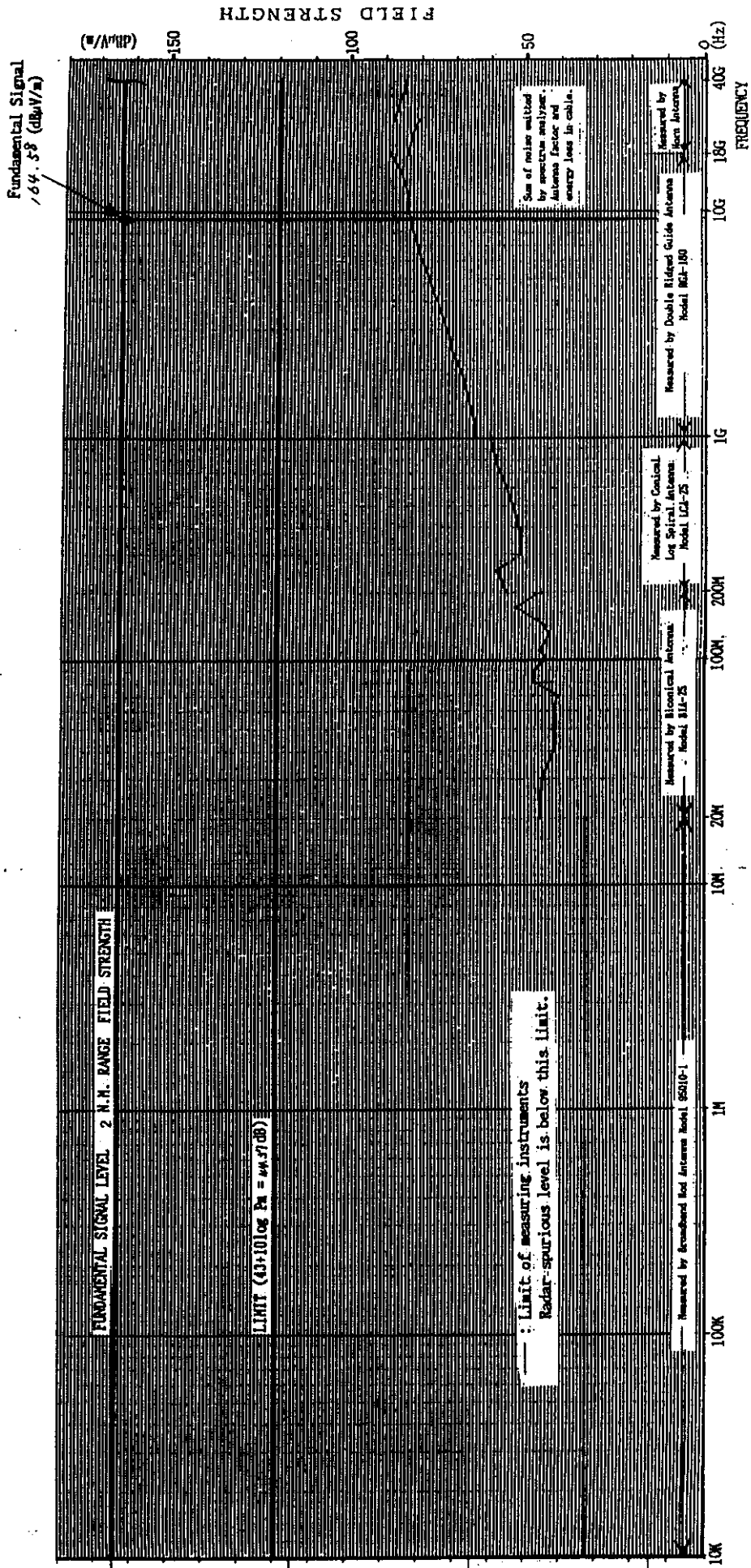

Graph 7 -> Field strength of spurious radiation measured with pick-up antenna (2 nm range)
 (middle Pulse)

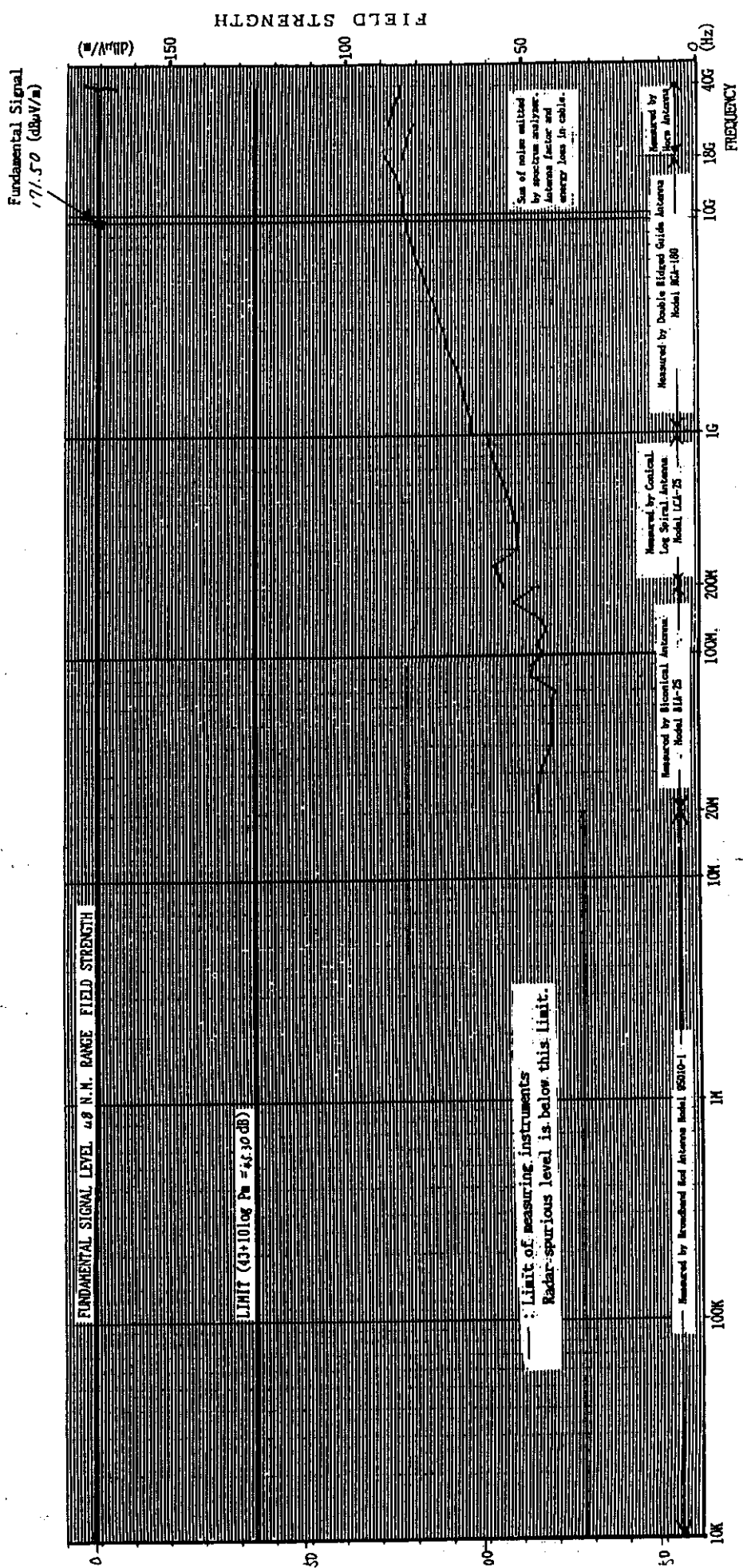

Graph 7-3 Field strength of spurious radiation measured with pick-up antenna (48 nm range)
 (long Pulse)



ATTACHMENT 3

[TEST DATA FOR 9. SUPPRESSION OF INTERFERENCE ABOARD SHIPS]

1. Harmful Interference to Receiver

Band: 14 kHz ~ 490 kHz

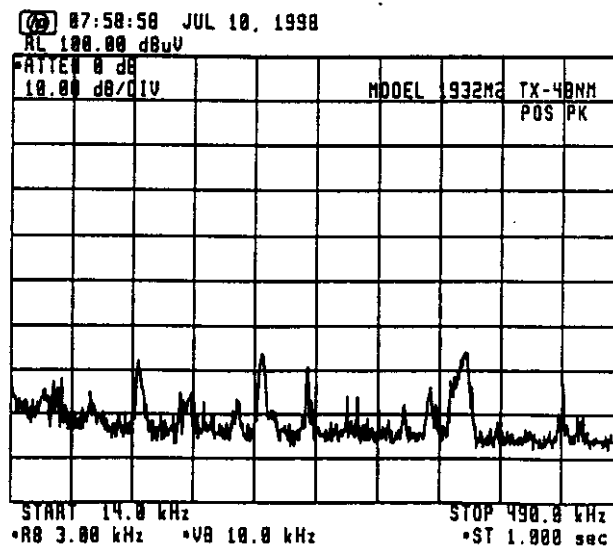
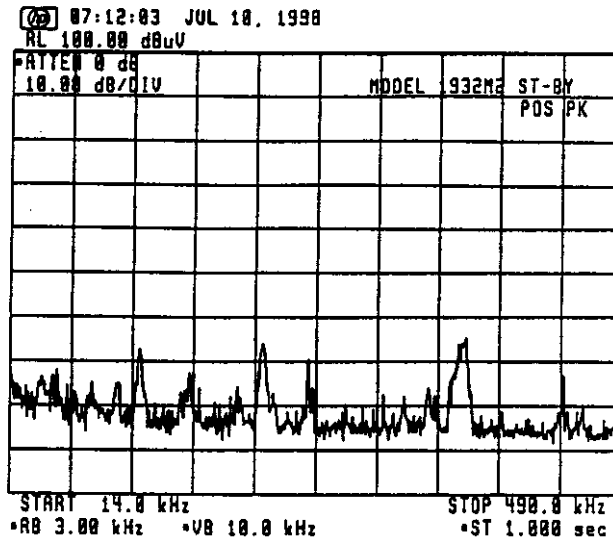
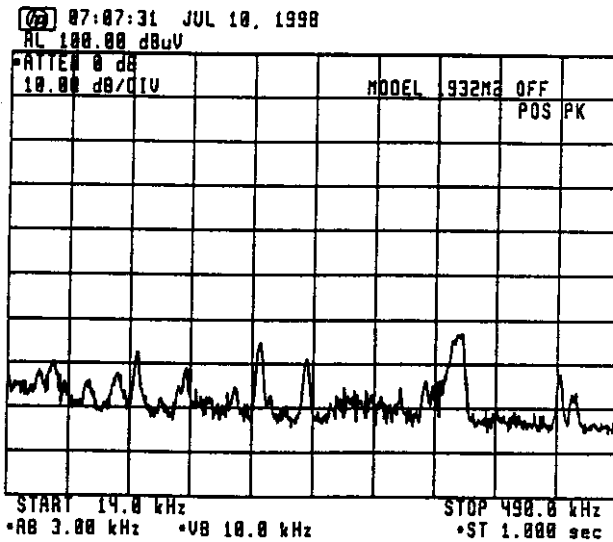

Band : 490 kHz ~ 5 MHz

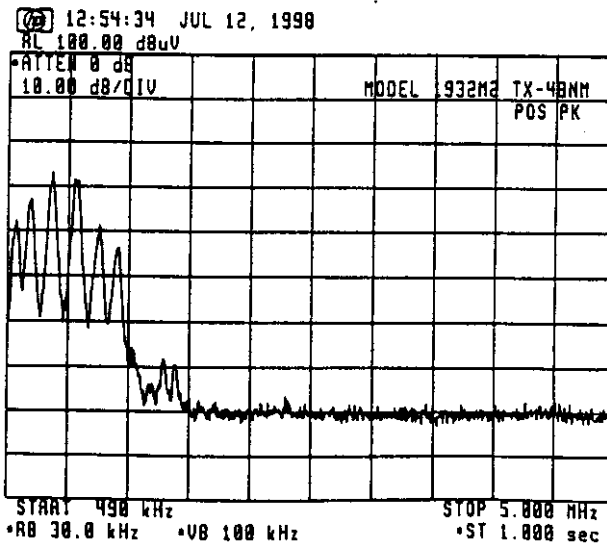
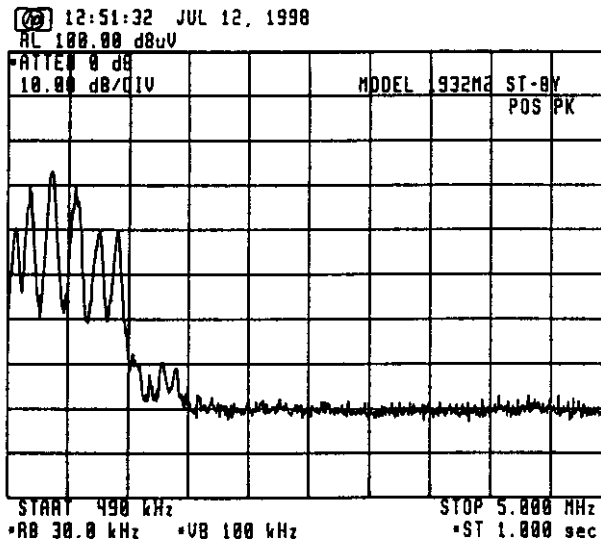
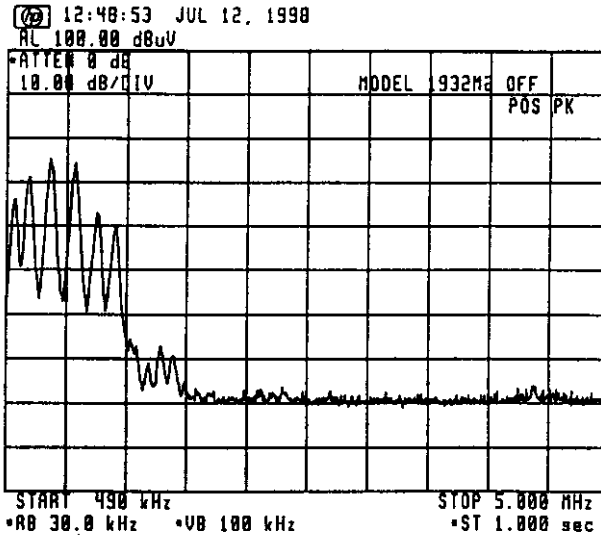

Band = 5MHz ~ 10MHz

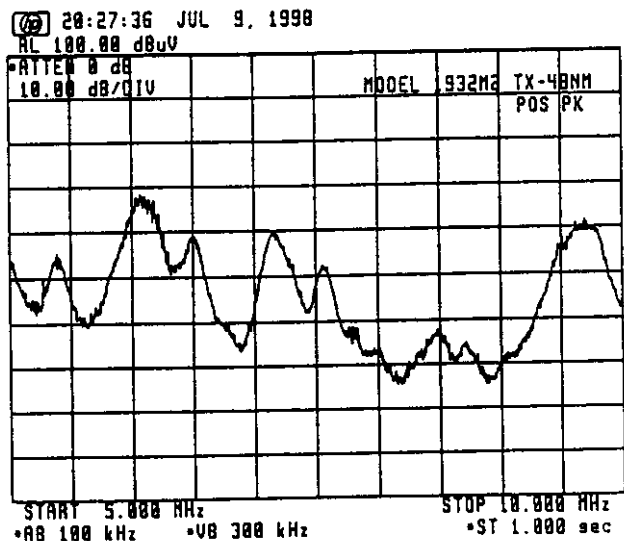
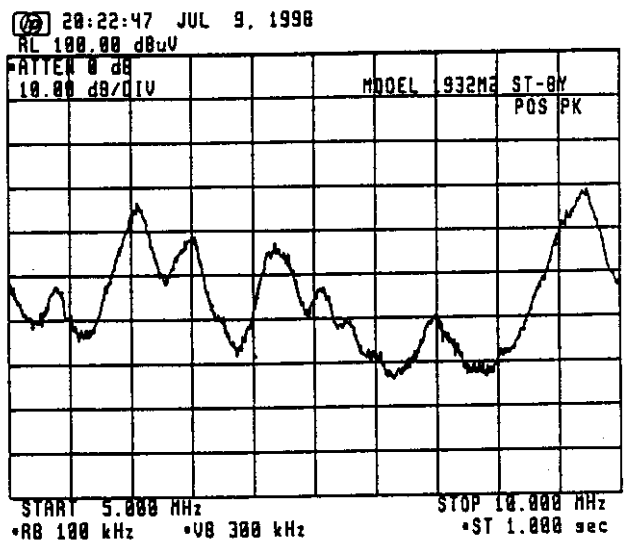
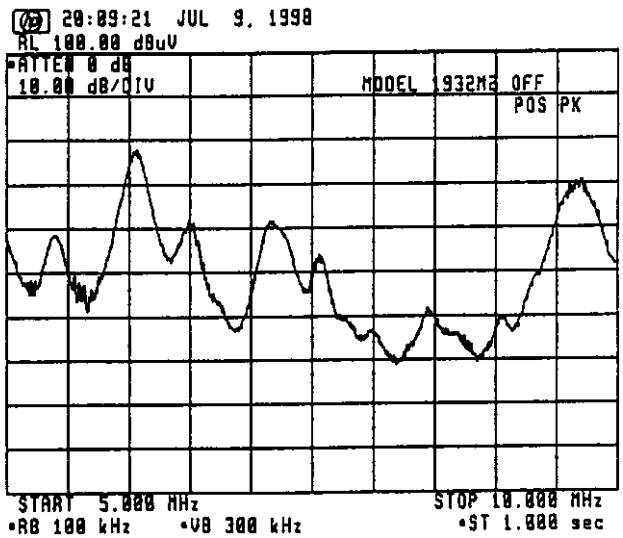

Band: 10MHz ~ 30MHz

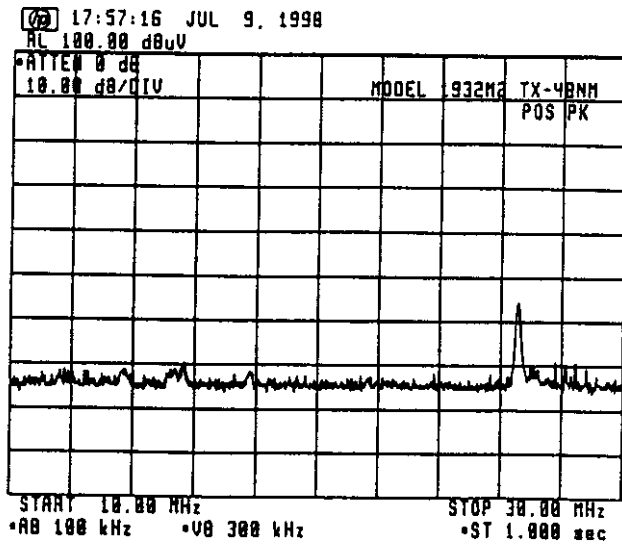
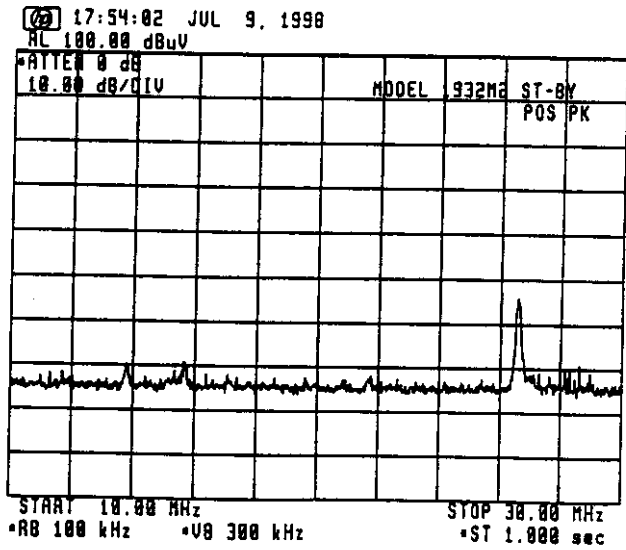
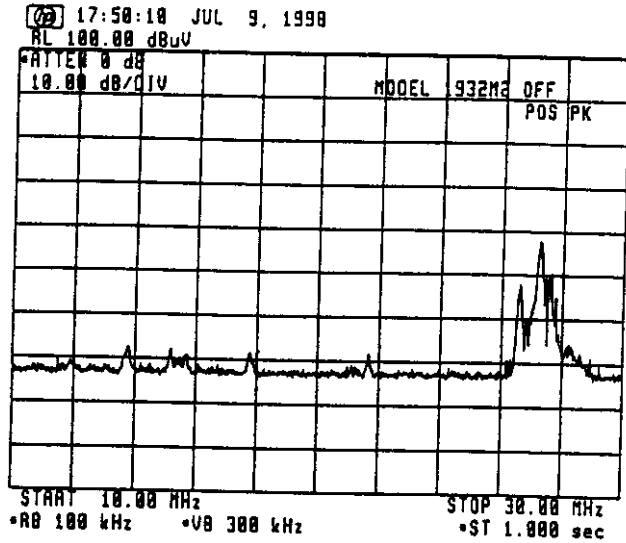

Band = 30MHz ~ 100MHz

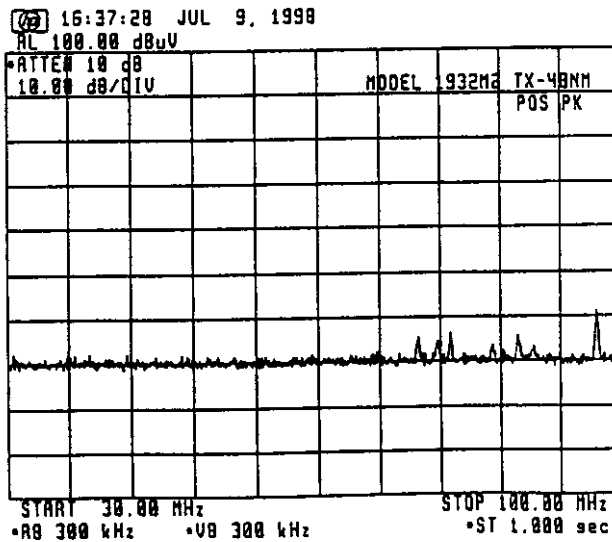
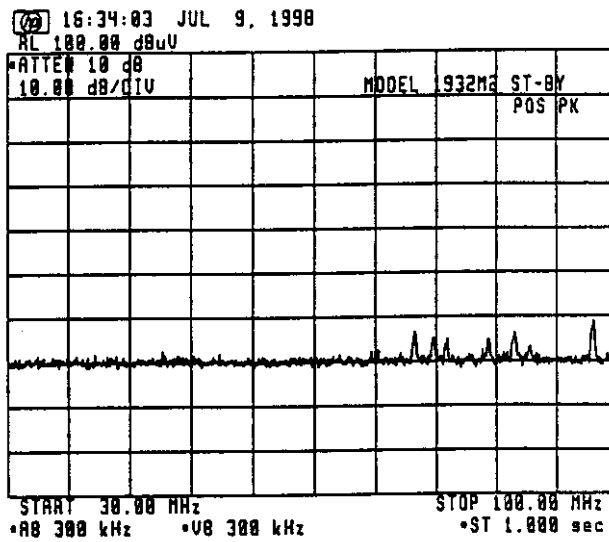
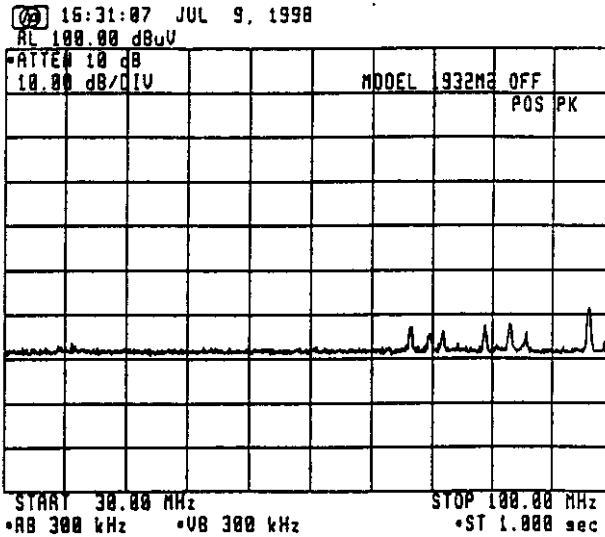

Band = 100MHz ~ 300MHz

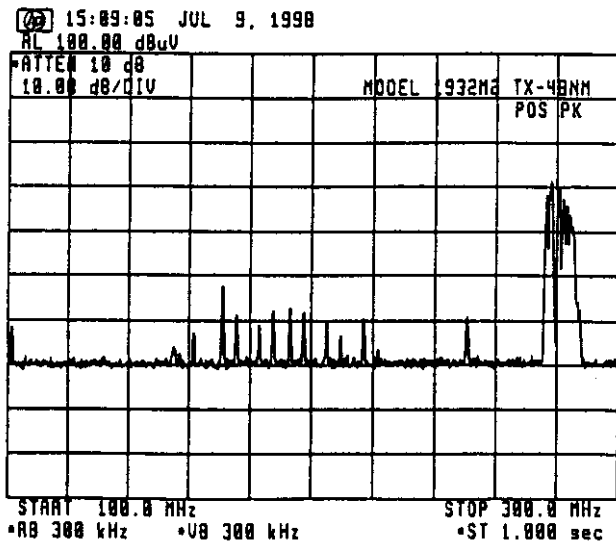
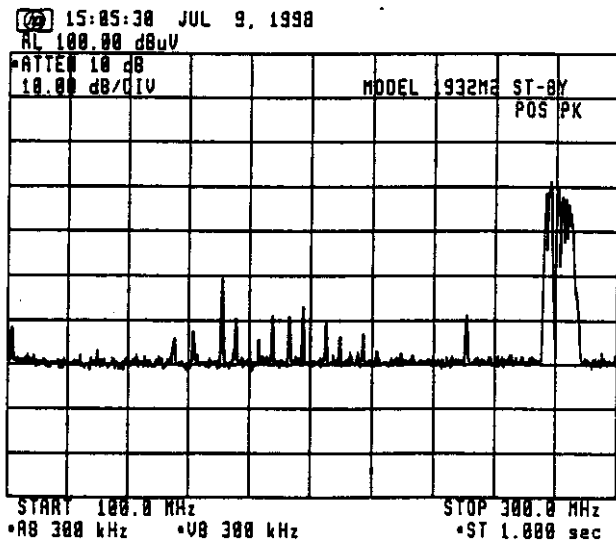
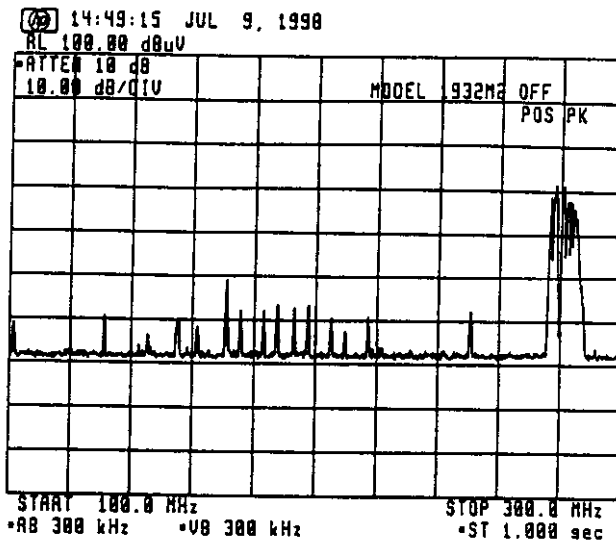

Band 300MHz ~ 1GHz

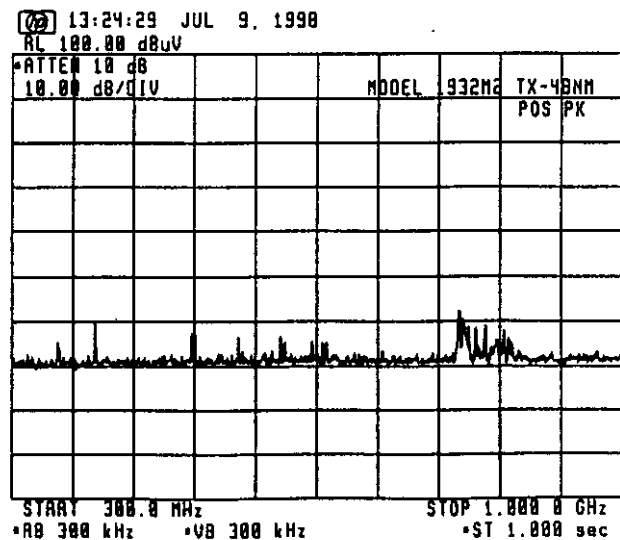
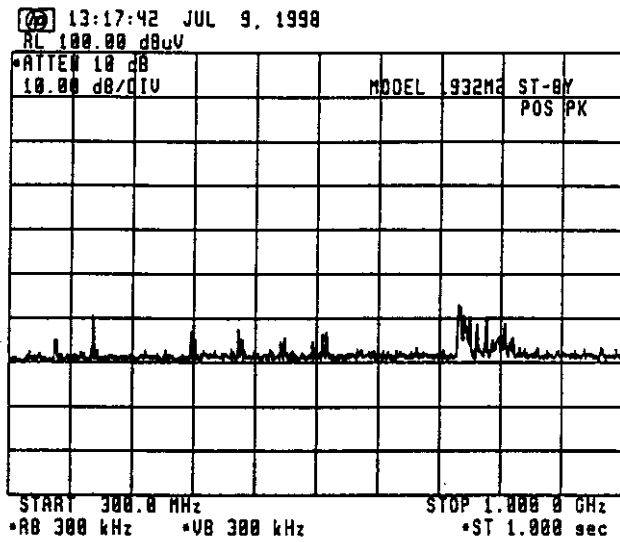
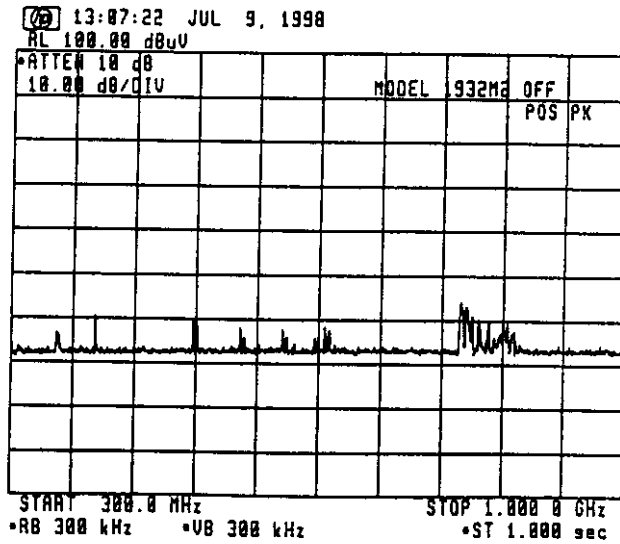

2. Electromagnetic Field

Band: 14kHz ~ 490kHz (Limit at 1N.M. = 0.1 μ V/m = -20dB μ V/m)

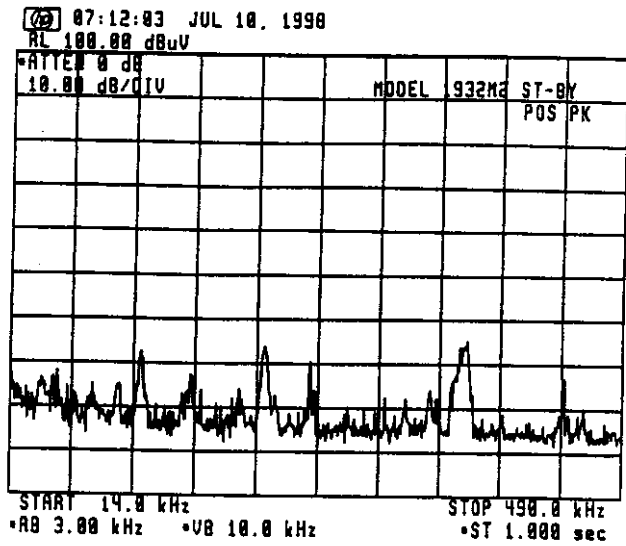
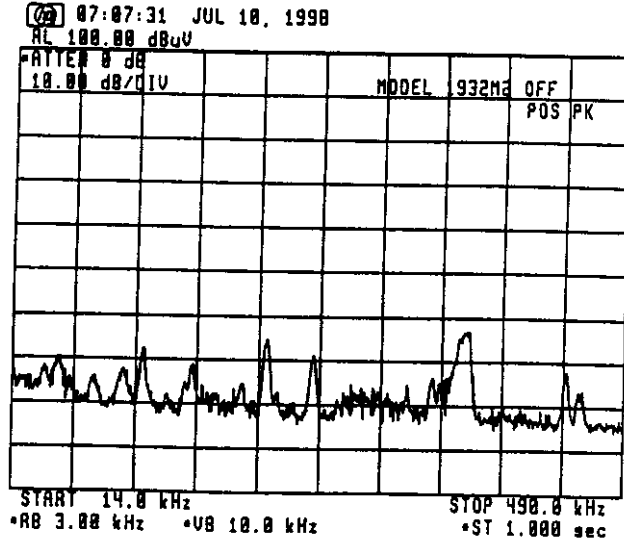

REF.
-26dB μ V/m

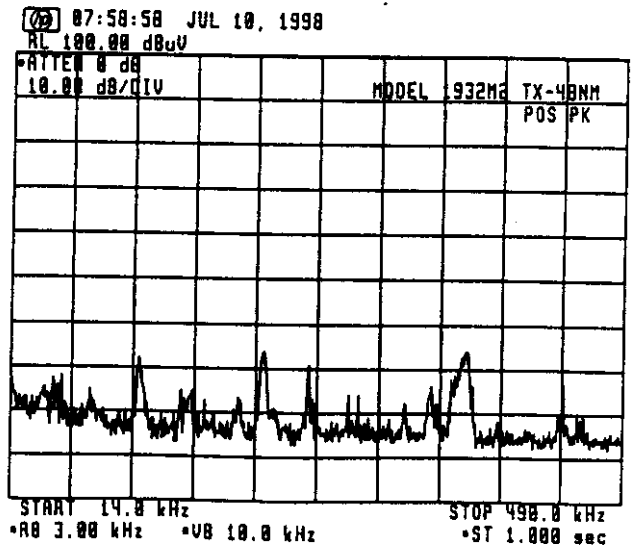

REF.
-26dB μ V/m

Band: 490kHz ~ 5MHz (Limit at 1N.M = 0.1 μ V/m = -20 dB μ V/m)

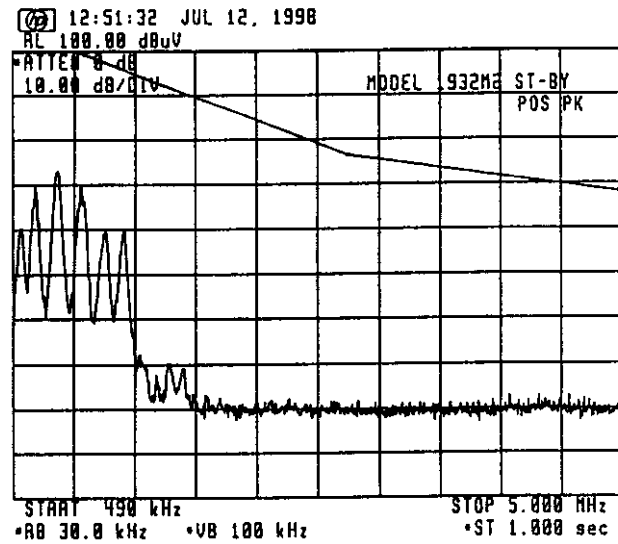
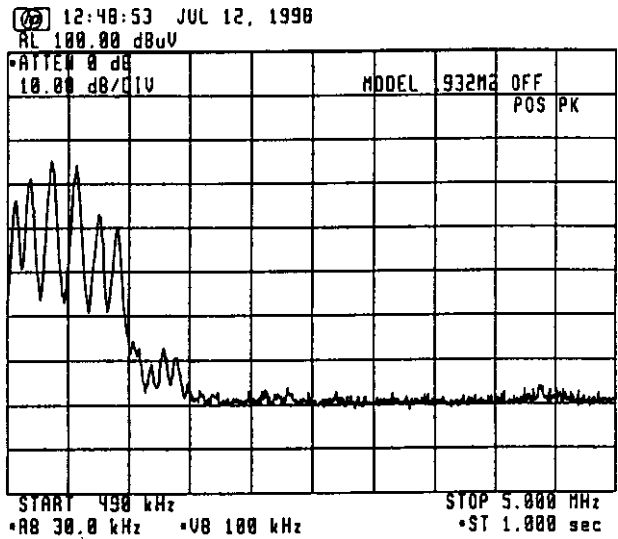

REF. (dB μ V/m)
 100 - 126 = -26 (0.5 MHz)
 100 - 96 = 4 (3 MHz)
 100 - 88 = 12 (5 MHz)

-20 dB μ V/m

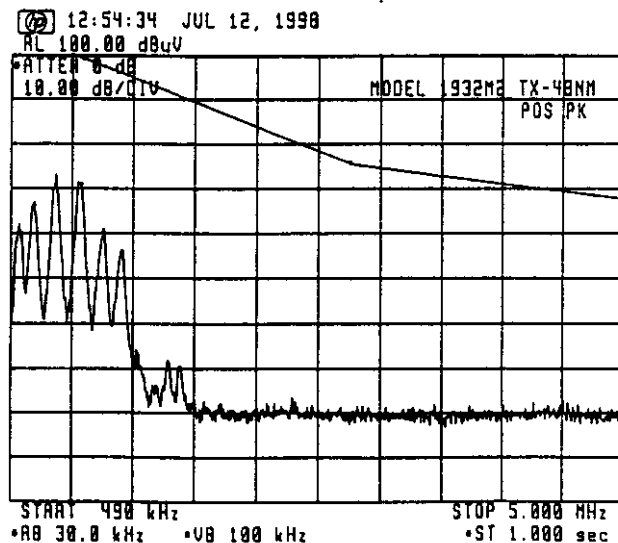

REF. (dB μ V/m)
 100 - 126 = -26 (0.5 MHz)
 100 - 96 = 4 (3 MHz)
 100 - 88 = 12 (5 MHz)

-20 dB μ V/m

Band: 3MHz ~ 10MHz (Limit at 1N.M. = 0.1µT/m = -20dBµT/m)

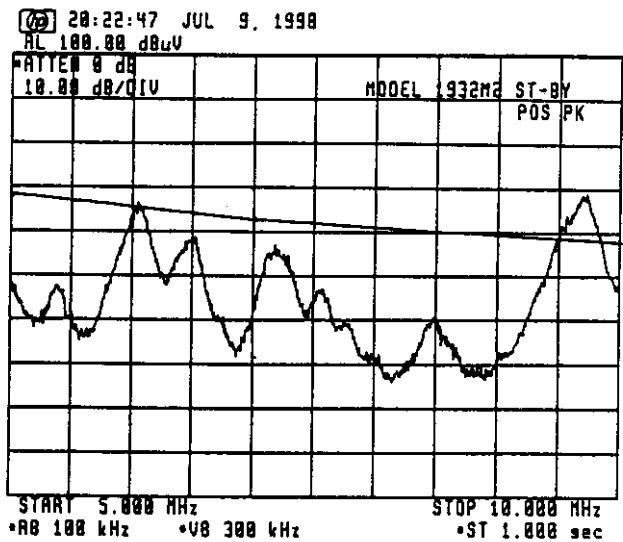
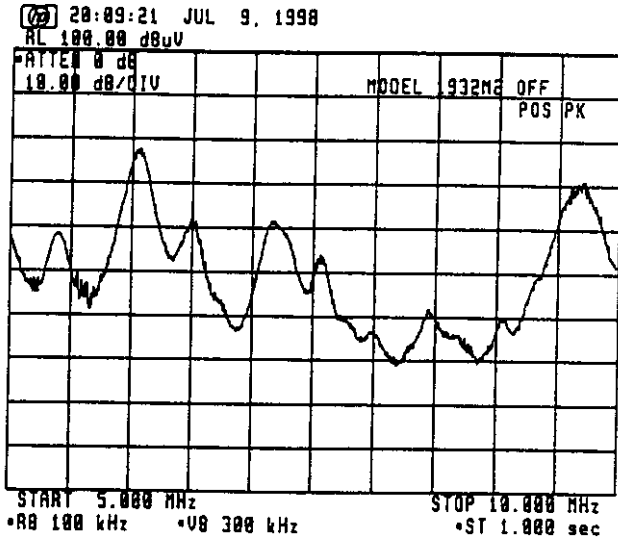

100-88 = 12 (5MHz)
 100-83 = 17 (7MHz)
 100-78 = 22 (10MHz)

-20dBµT/m

ALL COMPONENTS ABOVE THE LIMIT ARE FROM EXTERNAL NOISE OR SIGNALS, NOT FROM RADAR.

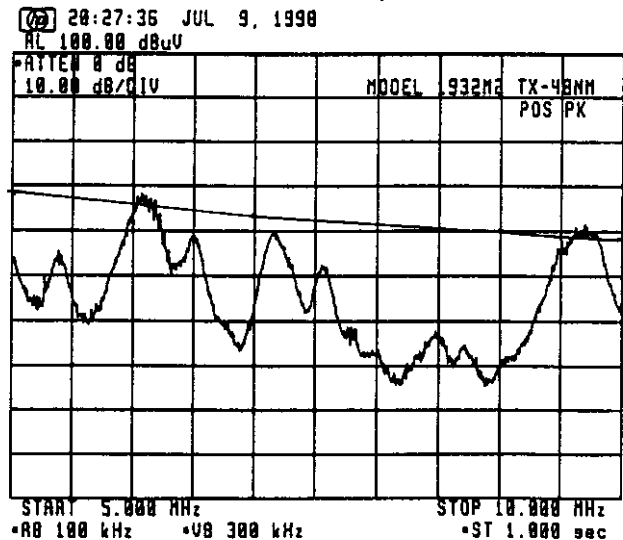

100-88 = 12 (5MHz)
 100-83 = 17 (7MHz)
 100-78 = 22 (10MHz)

ALL COMPONENTS ABOVE THE LIMIT ARE FROM EXTERNAL NOISE OR SIGNALS, NOT FROM RADAR.

Band: 10MHz ~ 30MHz (Limit at 1N.M. = 0.1 μ V/m = -20dB μ V/m)

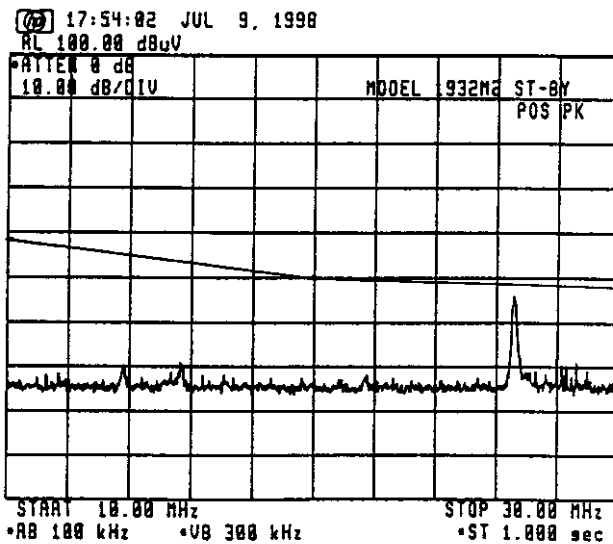
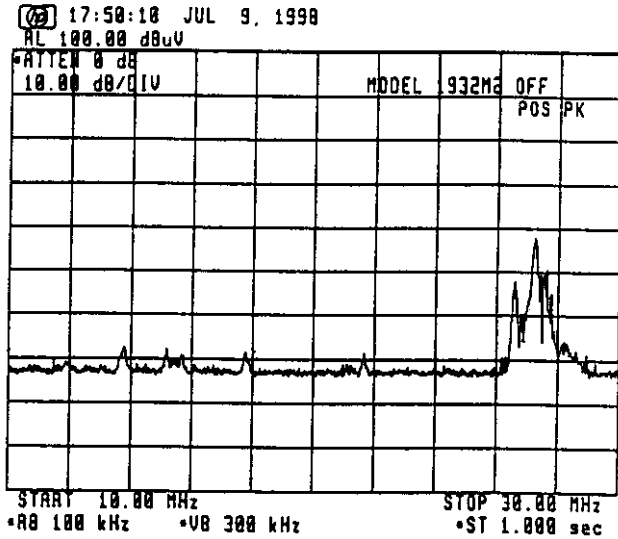

REF. (dB μ V/m)
 100 - 78 = 22 (10MHz)
 100 - 70 = 30 (20MHz)
 100 - 67 = 33 (30MHz)

-20dB μ V/m

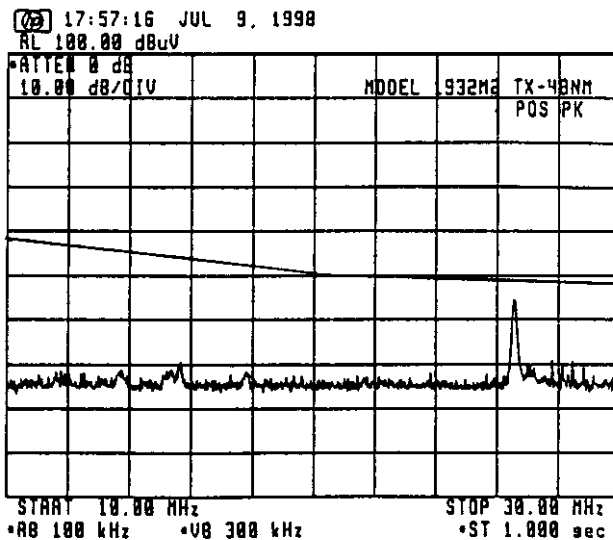

REF. (dB μ V/m)
 100 - 78 = 22 (10MHz)
 100 - 70 = 30 (20MHz)
 100 - 67 = 33 (30MHz)

-20dB μ V/m

Band = 100MHz ~ 300MHz (Limit at 1N.M. = $1\mu\text{V}/\text{m} = 0\text{dB}\mu\text{V}/\text{m}$)

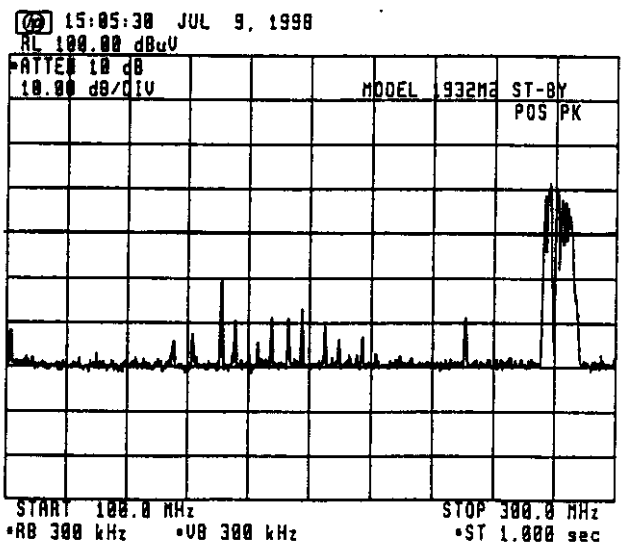
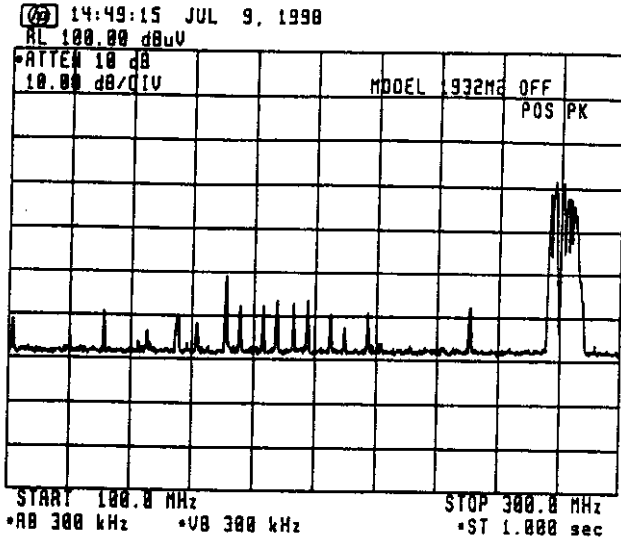

REF. ($\text{dB}\mu\text{V}/\text{m}$)
 $100 - 60 = 40$

$0\text{dB}\mu\text{V}/\text{m}$
 ALL COMPONENTS ABOVE
 THE LIMIT ARE FROM
 EXTERNAL NOISE OR SIGNALS,
 NOT FROM RADAR.

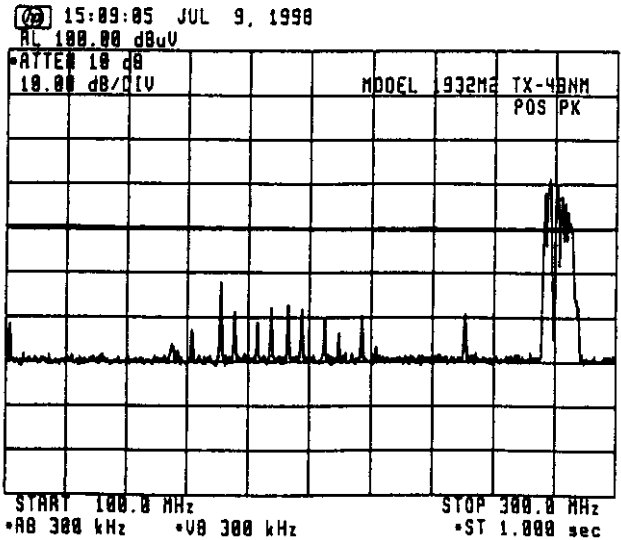

REF. ($\text{dB}\mu\text{V}/\text{m}$)
 $100 - 60 = 40$

$0\text{dB}\mu\text{V}/\text{m}$
 ALL COMPONENTS ABOVE
 THE LIMIT ARE FROM
 EXTERNAL NOISE OR SIGNALS,
 NOT FROM RADAR.

Band: 300MHz ~ 1GHz (Limit at 1N.M. = $3\mu\text{V/m} = 9.5\text{dB}\mu\text{V/m}$)

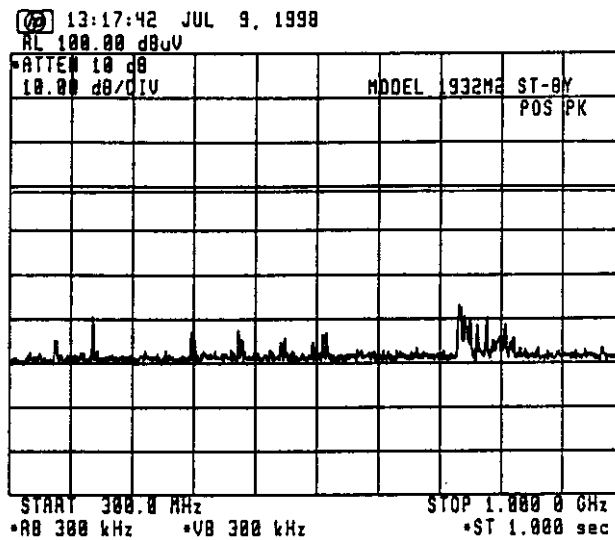
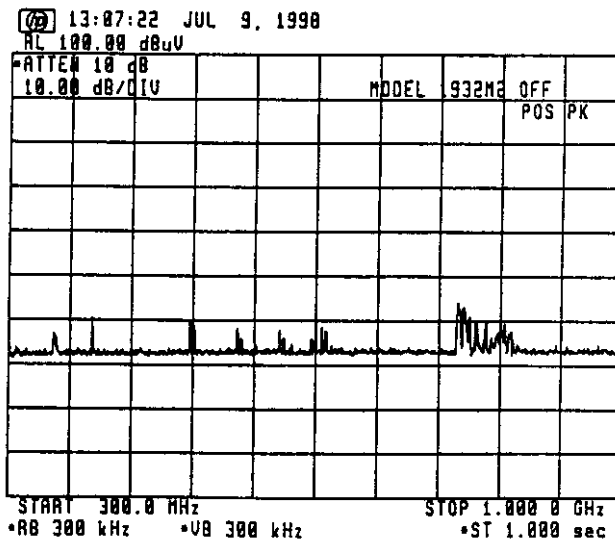

REF. (dB $\mu\text{V/m}$)
 $100 - 59.5 = 40.5$

9.5 dB $\mu\text{V/m}$

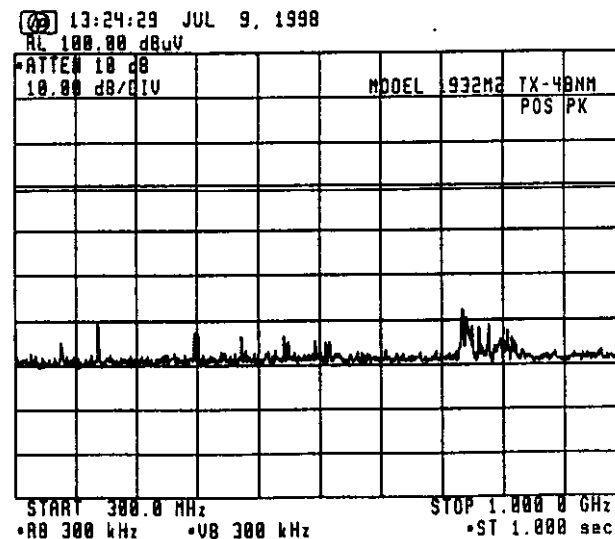

REF. (dB $\mu\text{V/m}$)
 $100 - 59.5 = 40.5$

9.5 dB $\mu\text{V/m}$

Band: 30MHz ~ 100MHz (Limit at 1N.M. = $0.3\mu\text{V}/\text{m} = -10.5\text{dB}\mu\text{V}/\text{m}$)

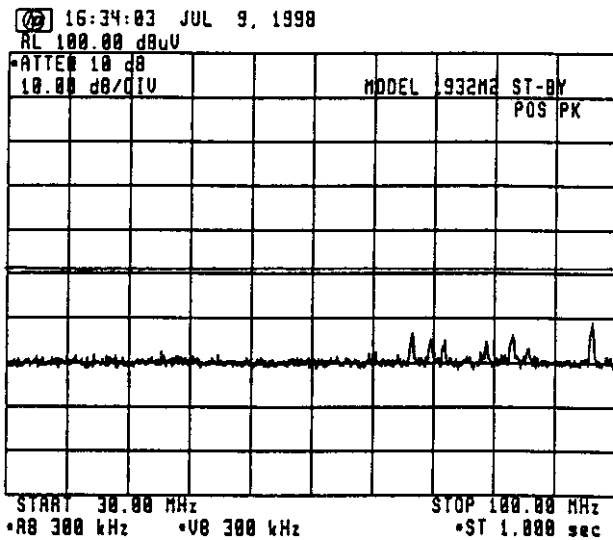
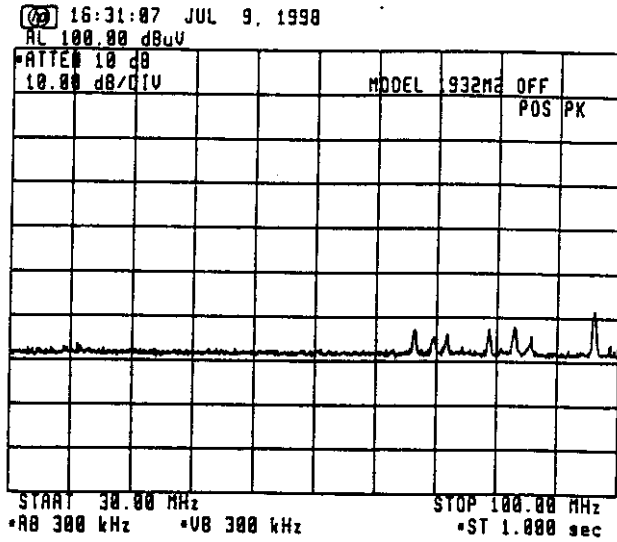

REF. (dB $\mu\text{V}/\text{m}$)
 100 - 61 = 39

-10.5 dB $\mu\text{V}/\text{m}$

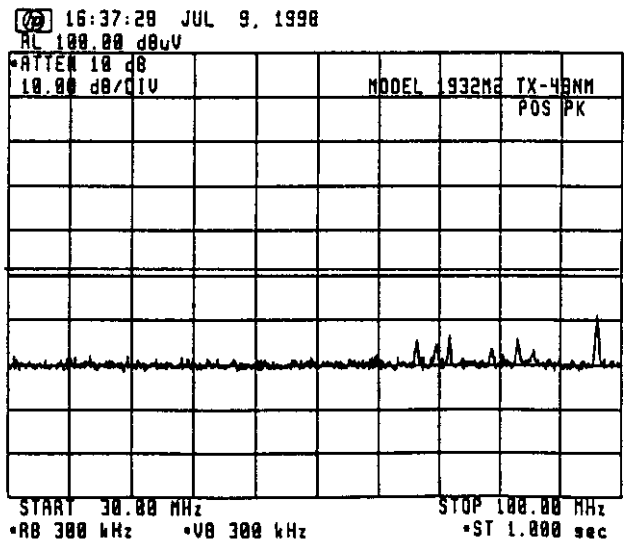

REF. (dB $\mu\text{V}/\text{m}$)
 100 - 61 = 39

-10.5 dB $\mu\text{V}/\text{m}$

3. Power Input to an Artificial Antenna

Band: 14kHz ~ 490kHz (Limit at 2 meter = -81dBm)

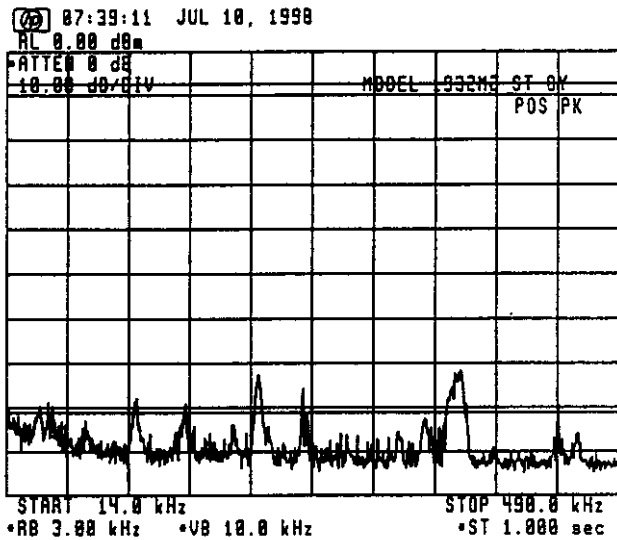
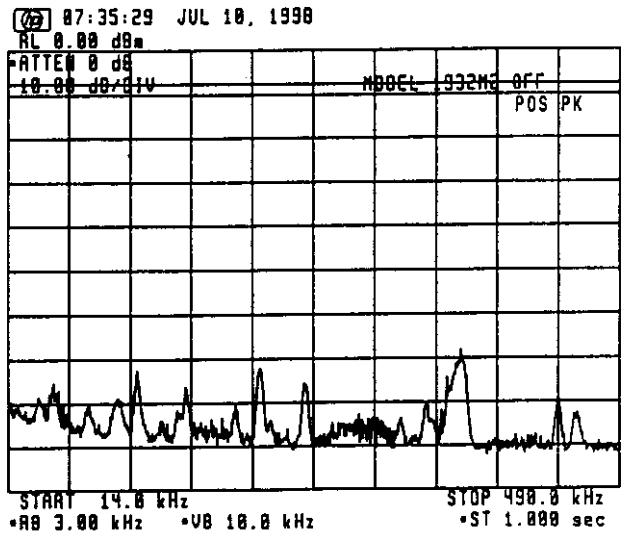

-81dBm
ALL COMPONENTS ABOVE
THE LIMIT ARE FROM
EXTERNAL NOISE OR SIGNALS,
NOT FROM RADAR.

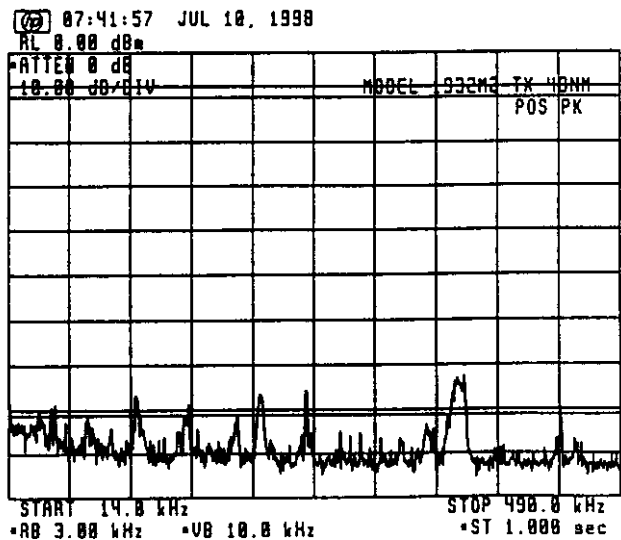

-81dBm
ALL COMPONENTS ABOVE
THE LIMIT ARE FROM
EXTERNAL NOISE OR SIGNALS,
NOT FROM RADAR.

Band = 490kHz ~ 5MHz (Limit at 2meter = -81dBm)

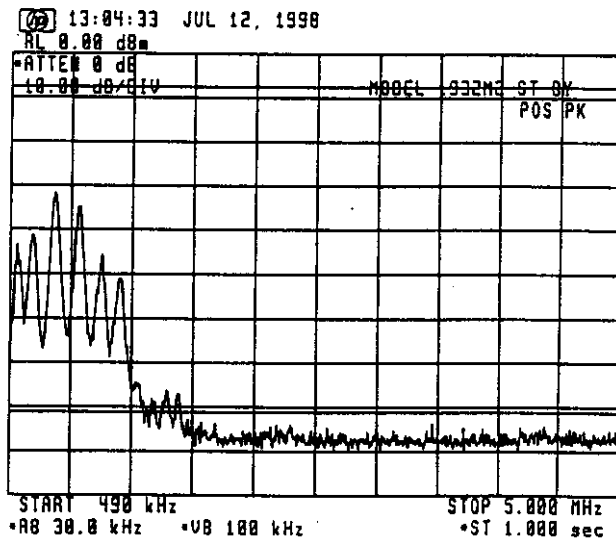
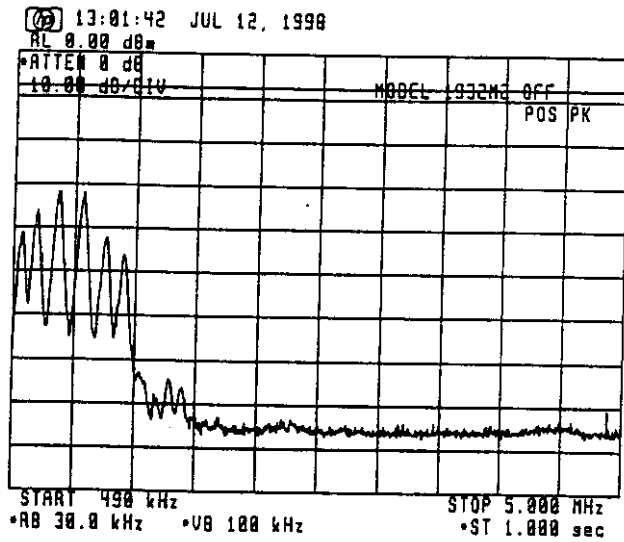

81 dBm

ALL COMPONENTS ABOVE
THE LIMIT ARE FROM
EXTERNAL NOISE OR SIGNALS,
NOT FROM RADAR.

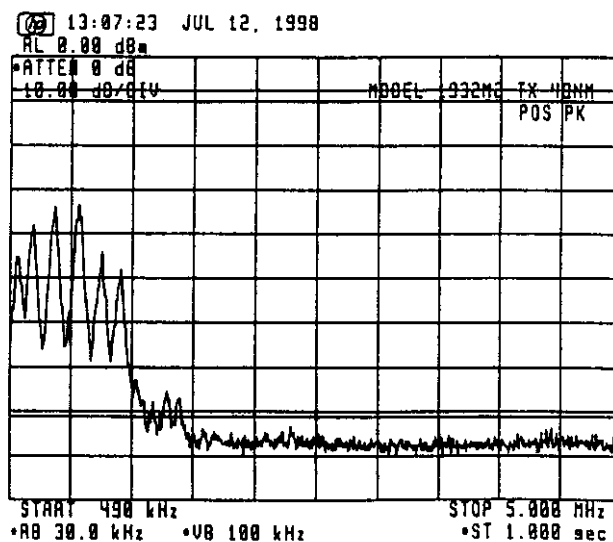

81 dBm

Band: 5MHz ~ 10MHz (Limit at 2 meter = -81dBm)

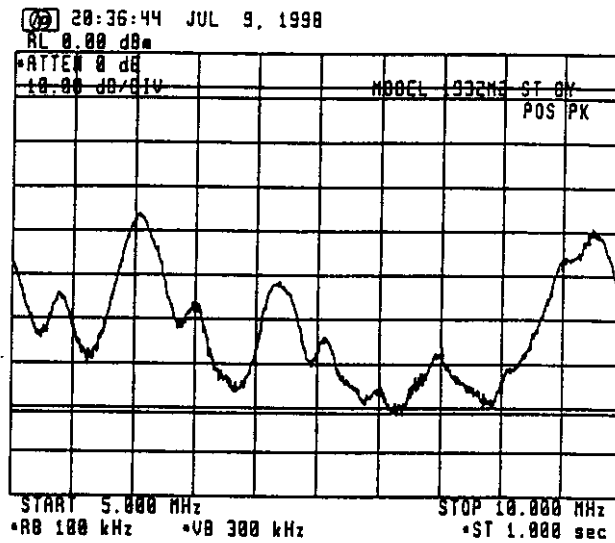
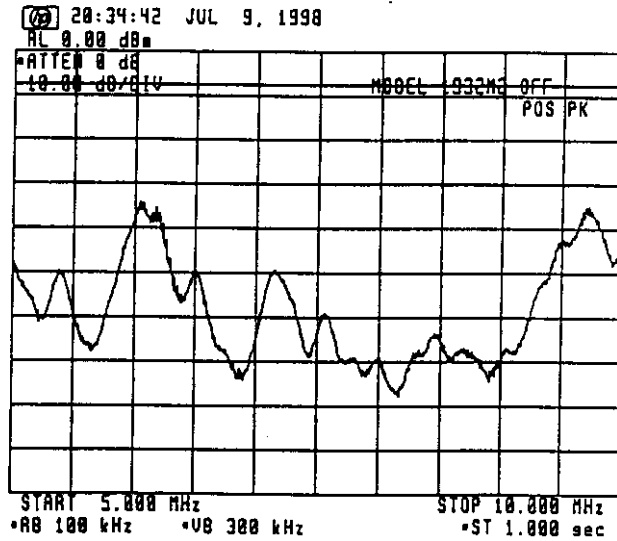

-81dBm

ALL COMPONENTS ABOVE
THE LIMIT ARE FROM
EXTERNAL NOISE OR SIGNALS,
NOT FROM RADAR.

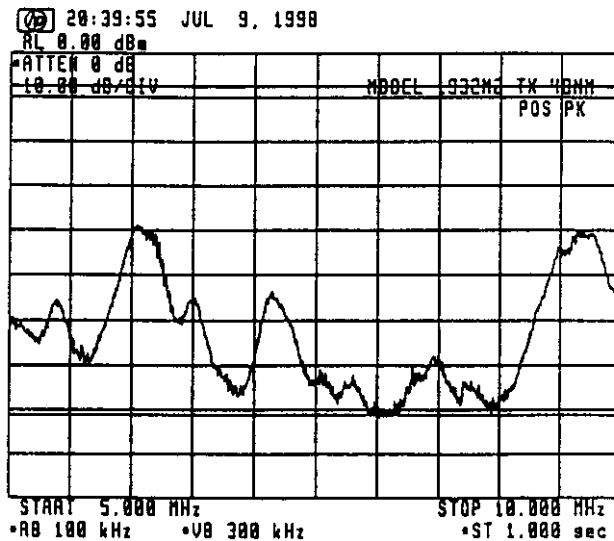

-81dBm

ALL COMPONENTS ABOVE
THE LIMIT ARE FROM
EXTERNAL NOISE OR SIGNALS,
NOT FROM RADAR.

Band: 10MHz ~ 30MHz (Limit at meter = -81dBm)

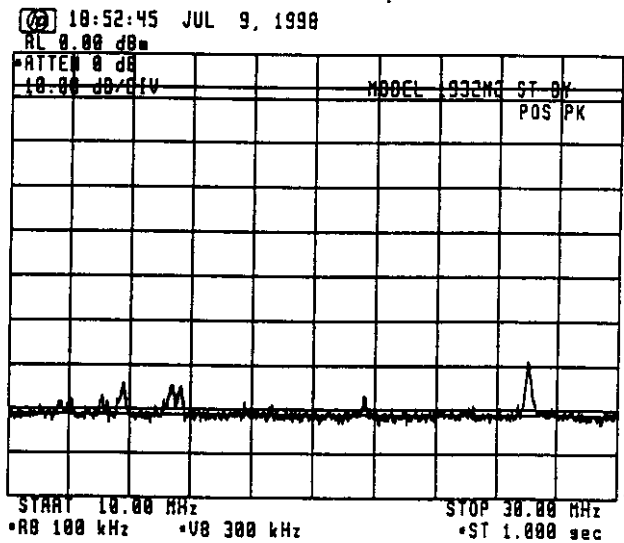
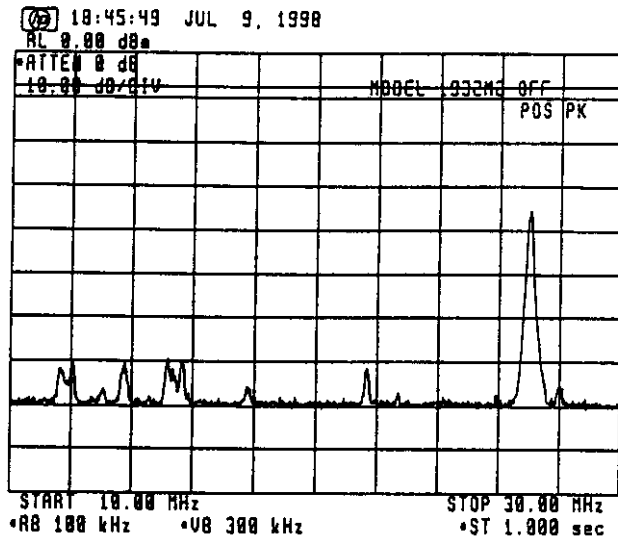

-81dBm
 ALL COMPONENTS ABOVE
 THE LIMIT ARE FROM
 EXTERNAL NOISE OR S. 'ALS,
 NOT FROM RADAR.

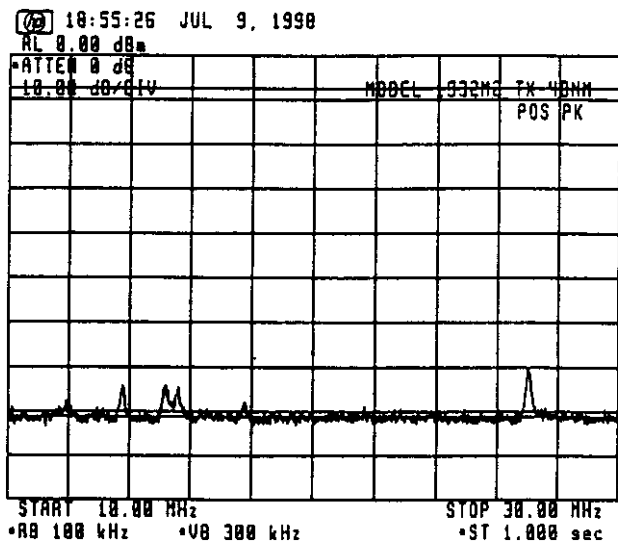

-81dBm
 ALL COMPONENTS ABOVE
 THE LIMIT ARE FROM
 EXTERNAL NOISE OR SIGNALS,
 NOT FROM RADAR.

Band: 30MHz ~ 100MHz (Limit at 2meter = -71dBm)

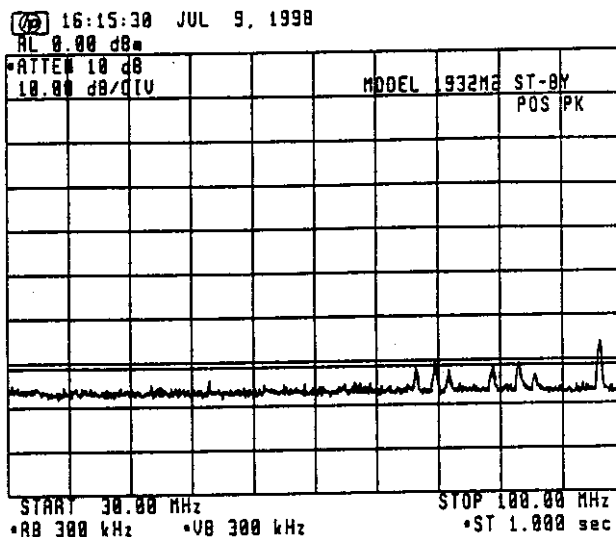
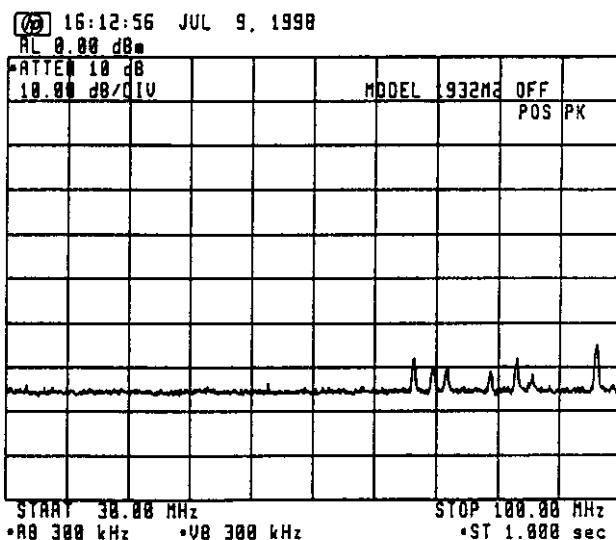

-71dBm
 ALL COMPONENTS ABOVE
 THE LIMIT ARE FROM
 EXTERNAL NOISE OR SIGNALS,
 NOT FROM RADAR.

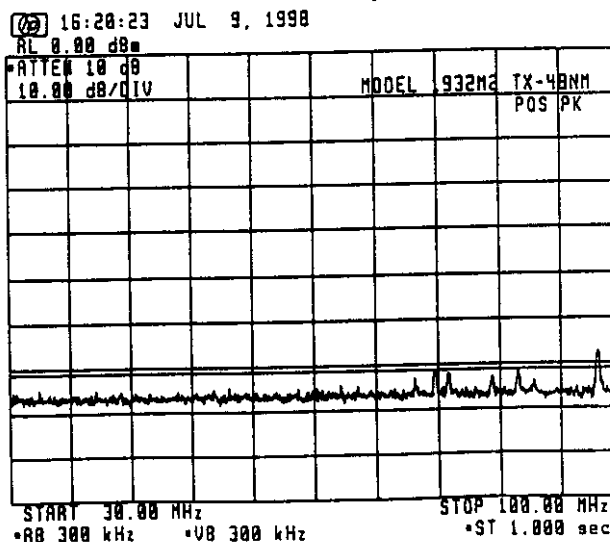

-71dBm
 ALL COMPONENTS ABOVE
 THE LIMIT ARE FROM
 EXTERNAL NOISE OR SIGNALS,
 NOT FROM RADAR.

Band: 100MHz ~ 300MHz (Limit at 2 meter = -61dBm)

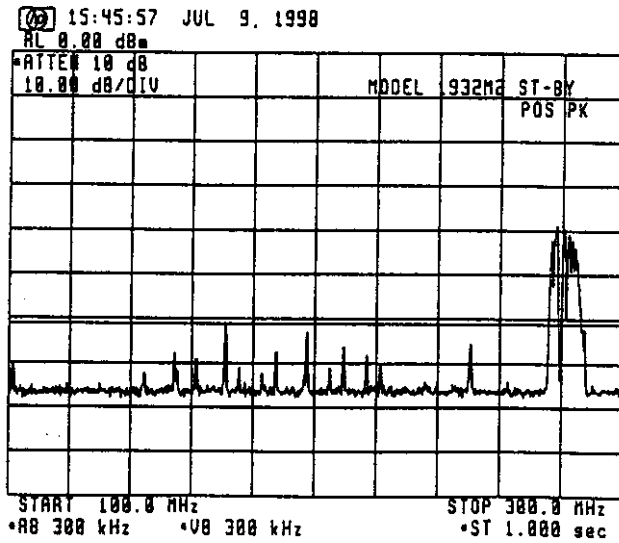
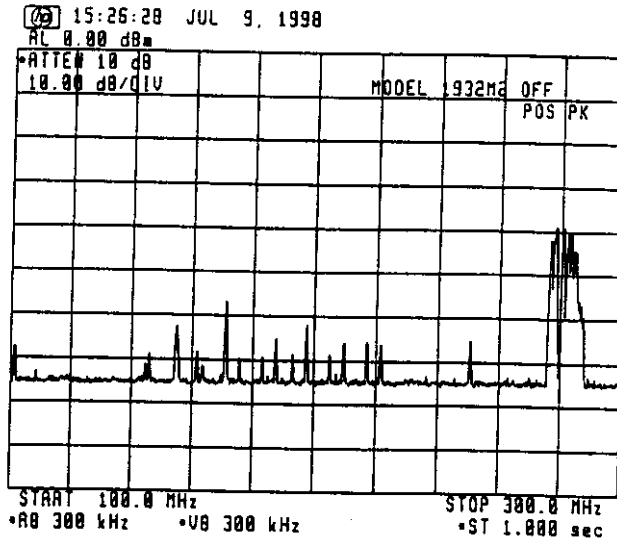

-61dBm
ALL COMPONENTS ABOVE
THE LIMIT ARE FROM
EXTERNAL NOISE OR SIGNALS,
NOT FROM RADAR.

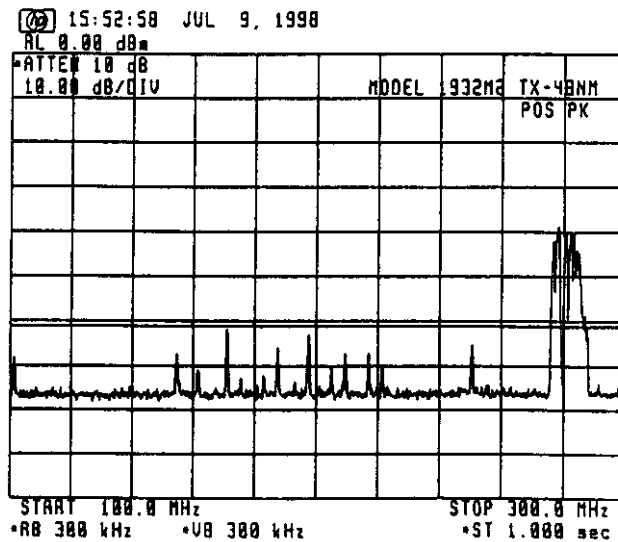

-61dBm
ALL COMPONENTS ABOVE
THE LIMIT ARE FROM
EXTERNAL NOISE OR SIGNALS,
NOT FROM RADAR.

Band: 300MHz ~ 1GHz (Limit at 2 meter = -51dBm)

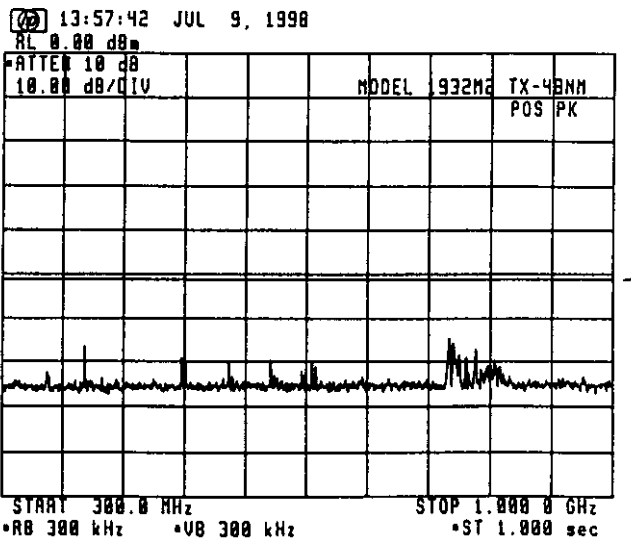
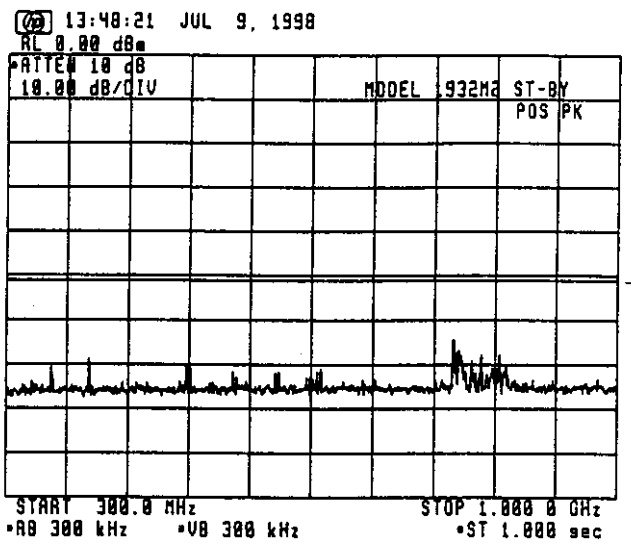
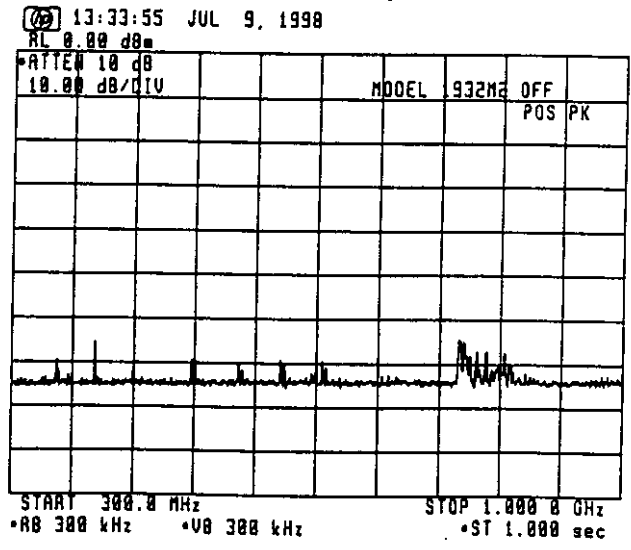



ATTACHMENT 4 [List of Test/Measuring Equipment]

3. RF Power Output

<u>Model</u>	<u>Type</u>	<u>Serial no.</u>	<u>Mfr.</u>
Spectrum Analyzer	71210C	2927A02847	HP
Oscilloscope	TDS680B	B030202	Tektronix
Directional Coupler	----	R94471	Shimada
Directional Coupler	5D364S	R05762	Shimada
Voltage Divider	P6015	900401	Tektronix
Current Transformer	2100	----	Pearson Electronics
Power Meter	436A	2410A19137	HP
Power Sensor	9481A	2349A39603	HP
Frequency Counter	TR5824A	41940036	Advantest
Frequency Meter	X532B	1441A00523	HP
Crystal Detector	423B	03696	HP
Step Attenuator	8494B	1510A07310	HP
Step Attenuator	8495B	1350A04754	HP
Dummy Load	----	8411057	Shimada

4. Modulation Characteristics

<u>Model</u>	<u>Type</u>	<u>Serial no.</u>	<u>Mfr.</u>
Oscilloscope	TDS680B	B030202	Tektronix
Step Attenuator	8494B	1510A07310	HP
Step Attenuator	8495B	1350A04754	HP
Crystal Detector	423B	1822A24214	HP
Directional Coupler	5D364S	R9425	Shimada
Dummy Load	-----	8411057	Shimada
Voltage Divider	P6015	900401	Tektronix
Spectrum Analyzer	71210C	2927A02847	HP
External Mixer:	11970K	----	HP
External Mixer:	11970A	----	HP
Directional Coupler	5D364S	R9425	Shimada

Pub. No.: TI-1697

Date: July, 1998

6. Spurious Emissions at Antenna Terminal

<u>Model</u>	<u>Type</u>	<u>Serial no.</u>	<u>Mfr.</u>
Spectrum Analyzer	71210C	2927A0847	HP
Attenuator (11dB/1dB)	8494B	1510A07310	HP
External Mixer:	11970K	----	HP
External Mixer:	11970A	----	HP
Directional Coupler	5D364S	R0576	Shimada
Dummy Load	-----	8411057	Shimada
Notch Filter	MA8L32#8	----	Microwave
High Pass Filter	MAS15905004	R9904	Shimada

7. Field Strength of Spurious Radiation

<u>Model</u>	<u>Type</u>	<u>Serial no.</u>	<u>Mfr.</u>
Broadband Rod Antenna	M 95010-1	0496	Advanced Electronics
Biconical Antenna	BIA-25	2650	Electro Metrics
Conical Log-Spiral Antenna	LCA-25	2886	Electro Metrics
Double Ridged Guide Horn Antenna:RGA-180		----	EMD
Horn Antenna:	----	----	Toshiba
Spectrum Analyzer:	71210C	2927A0287	HP
External Mixer:	11970K	----	HP
External Mixer:	11970A	----	HP

8. Frequency Stability

<u>Model</u>	<u>Type</u>	<u>Serial no.</u>	<u>Mfr.</u>
Power Meter:	436A	2410A19137	HP
Power Sensor:	8481A	2349A39603	HP
Frequency Meter:	X532B	1441A00523	HP
Directional Coupler:	5D364S	R9425	Shimada
Dummy Load:	----	8411057	Shimada
Environmental Chamber:	PL-4E	1632712	Tabai Espec

Pub. No. : TI-1697

Date : July, 1998

9. Suppression of Interference Aboard Ships

<u>Model</u>	<u>Type</u>	<u>Serial no.</u>	<u>Mfr.</u>
Spectrum Analyzer:	71210C	2927A02847	HP
6 m Whip Antenna	14 k - 10 MHz	----	Furuno
4 m Whip Antenna	10 - 30 MHz	----	Furuno
VHF Whip Antenna	30 - 300 MHz	150M-W2UM	Anten
UHF Whip Antenna	300 - 1000 MHz	----	Anten
RF Vector Impedance Meter:	4815A	2048A03354	HP
Spectrum Analyzer	TR4172	30690116	Advantest
Spectrum Analyzer	8566B	2637A03642	HP

