



333 Bayview Avenue, Amityville, New York 11701
 For Sales and Repairs, (800) 645-9445
 For Technical Service, (800) 645-9440 or visit us at
Tech.NapcoSecurity.com
 (Note: Technical Service is for security professionals only)
 Publicly traded on NASDAQ Symbol: NSSC

© NAPCO 2023

GEM-SMK-CO-E SUPERVISED DIGITAL WIRELESS SMOKE / CARBON MONOXIDE DETECTOR INSTALLATION INSTRUCTIONS

WI2546.aLF 12/23

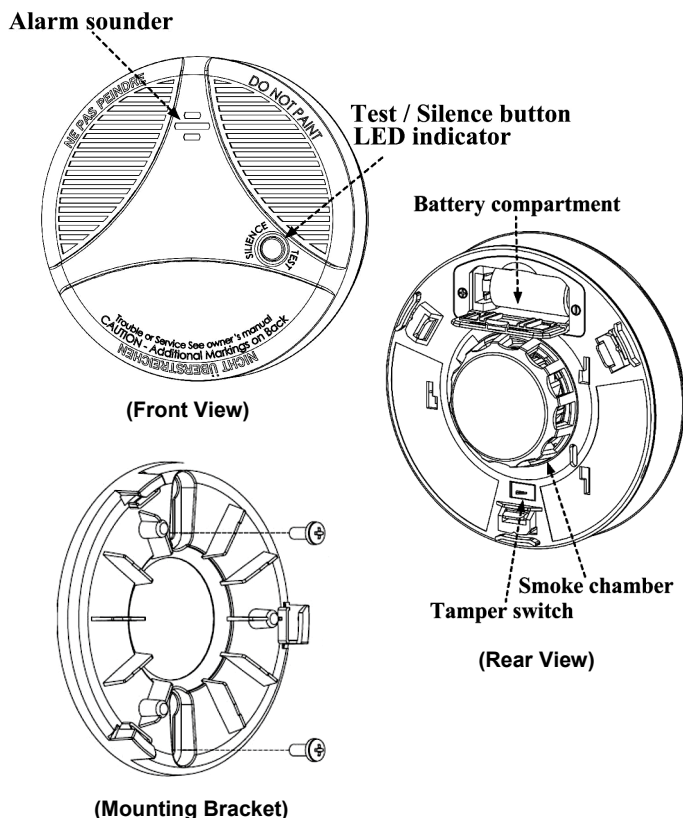

and/or CO is detected, the unit sounds a local alarm, and the transmitter sends an alarm signal to the supervised receiver. The alarm signal is repeated every 10 seconds thereafter if smoke or CO is still present. A restore report is sent when the smoke/CO detection chamber clears. Smoke and CO supervisory status reports are sent from the unit every hour. Each **GEM-SMK-CO-E** detector is assigned two RF IDs for each function -- an ID for smoke and another ID for CO. Coding switches are not required. **Note:** The **GEM-SMK-CO-E** must be installed in accordance with the National Fire Protection Association NFPA 720.

The **GEM-SMK-CO-E** includes the following features:

- Easy to install
- Continuous monitoring for carbon monoxide and smoke
- Loud 85dB alarm sounder
- **Test/Silence** button
- Continuous self-diagnostic testing
- 10 year detector life. Approximately 3 year battery life under normal operating conditions (reports low battery condition to assist with maintenance)

SPECIFICATIONS

ETL Certified, conforms to UL 2075 that has already established the carbon monoxide concentrations and exposure time standards for this detector: At 70ppm, the detector must alarm within 60-240 minutes. At 150ppm, the detector must alarm within 10-50 minutes. At 400ppm, the detector must alarm within 4-15 minutes.

Electrical Ratings

Input Power: Powered by a replaceable 3-volt lithium battery. Use one 3-volt lithium Duracell DL123A or Panasonic CR123A.

Dimensions (W×L×D): 5-3/8 x 5-3/8 x 2-1/8" (13.7 x 13.7 x 5.4cm)

Operating Environment

Temperature: 40°F to 100°F (4.4°C to 37.8°C)

Regulatory Information

Rating: This detector has been evaluated by ETL and conforms to the CO detector sensitivity limits of UL 2075 and also conforms to Smoke Detectors UL 268, as indicated in the **SPECIFICATIONS** section above. **Note:** When used as a Smoke-CO detector the unit must be installed in accordance with NFPA 720. When used as a smoke detector, install in accordance with NFPA 72.

Environmental Class: Indoor, in accordance with the Operating Environment specifications.

INTRODUCTION

The **GEM-SMK-CO-E** is a high-quality combination photoelectric smoke detector (conforms to UL 268) and carbon monoxide detector (conforms to UL 2075) and is equipped with a supervised digitally coded radio transmitter. It is compatible with NAPCO's GEM-RECV and GEMC-RECV series supervised receivers that monitor alarms, restores, low battery, tamper, and status; for use with NAPCO's GEM and GEMC series Control Units. **Note:** See Control Unit installation instructions for compatibility.

During normal operation, the green LED on the **GEM-SMK-CO-E** flashes once every 50 seconds. As soon as smoke

TABLE OF CONTENTS

Introduction.....	1
Specifications.....	1
Product View.....	1
Information About Carbon Monoxide.....	1
Possible Symptoms of Carbon Monoxide Poisoning.....	2
Situations Where Detector is Ineffective.....	2
Locations to Install Your Detector.....	2
Locations Not to Install Your Detector.....	4
Installing Your Detector.....	4
Warning Signals (Details).....	5
Summary of Warning Signals.....	6
General Maintenance.....	6
If CO Alarm Activates.....	7
Actions to Take After the Problem is Corrected.....	7
If Smoke Alarm Activates.....	7
Limitations of Wireless Devices.....	7
Limited Warranty.....	8

INFORMATION ABOUT CARBON MONOXIDE

Carbon monoxide, also known as "CO", is a highly dangerous poisonous gas because it is colorless, odorless, tasteless, and very toxic. The presence of CO gas inhibits the blood's ability to transport oxygen throughout the body, eventually leading to brain damage. In any enclosed space (home, office, recreational vehicle or boat) even a small accumulation of CO gas can be dangerous. Although many products of combustion

can cause discomfort and adverse health effects, CO gas presents one of the greatest threats to life.

Carbon monoxide is produced by the incomplete combustion of fuels such as natural gas, propane, heating oil, kerosene, coal, charcoal, gasoline, and wood. This incomplete combustion of fuel can occur in any device which depends on burning for energy or heat such as furnaces, boilers, room heaters, hot water heaters, stoves, grills, and in any gasoline powered vehicle or engine (e.g., generators and lawnmowers). Tobacco smoke also adds CO to the air you breathe.

When properly installed and maintained, natural gas furnaces and hot water heaters do not pollute the air with CO. Natural gas is known as a "clean burning" fuel because under correct operating conditions, the combustion products are water vapor and *carbon dioxide* (CO₂), which is not toxic. The products of combustion are exhausted from furnaces and water heaters to the outside by means of a fuel duct or chimney.

Correct operation of any burning equipment requires two key conditions:

- An adequate supply of air for complete combustion
- Proper venting of the products of combustion from the furnace through a chimney, vent, or duct to the outside

Summary of typical carbon monoxide gas issues:

- Equipment problems due to defects, poor maintenance, or damaged heat exchangers
- Collapsed or blocked chimneys or flues, dislodged, disconnected, or damaged vents
- Downdraft in chimneys or flues can be caused by very long or circuitous flue runs, improper location of flue exhaust or wind conditions
- Improper installation or operation of equipment, chimney, or vents
- Air tightness: Premises with minimal air leakage (very tight) may cause increased risk for back-drafting of combustion appliances. This may be caused by exhaust fans creating negative house pressures that could lead to unsafe levels of carbon monoxide
- Inadequate exhaust of space heaters or appliances
- Exhaust ventilation or active fireplace competing for oxygen supply
- Potential sources of carbon monoxide in your home or office include: Clogged chimneys, wood stoves, wood or gas fireplaces, automobiles and garages, gas water heaters, gas appliances, gas or kerosene heaters, gas or oil furnaces, and tobacco smoke

POSSIBLE SYMPTOMS OF CARBON MONOXIDE POISONING

- Carbon monoxide is colorless, odorless, tasteless, and very toxic. When inhaled, it produces an effect known as chemical asphyxiation. Injury is due to the combining of CO with the available hemoglobin in the blood, thus lowering the oxygen-carrying capacity of the blood. In the presence of CO gas, the body is quickly affected by oxygen starvation. The following symptoms are related to CO poisoning and should be discussed with all members of the household so that you know what to look for:
- Extreme exposure: Unconsciousness, convulsions, cardio-respiratory failure, death
- Medium exposure: Severe throbbing headache, drowsiness, confusion, vomiting, fast heart rate
- Mild exposure: Slight headache, nausea, fatigue ("flu-like" symptoms)

Many victims of carbon monoxide poisoning indicate that

while they were aware that they were ill, they became so disoriented that they were unable to help themselves by either exiting the building or calling for assistance. Young children and household pets may be the first affected. Exposure during sleep is particularly dangerous because the victim usually does not wake.

SITUATIONS WHERE THE SMOKE DETECTOR IS INEFFECTIVE

- Fires where the victim is in direct contact with a flaming initiated fire; for example, when a person's clothes catch fire while cooking
- Fires where the smoke is prevented from reaching the smoke detector due to a closed door or other obstruction
- Incendiary fires where the fire grows so rapidly that an occupant's egress is blocked even with properly located smoke detectors

LOCATIONS TO INSTALL YOUR DETECTOR

For CO detector:

Since CO gas moves freely in the air, the suggested location is in or as near as possible to sleeping areas of the home. The human body is most vulnerable to the effects of CO gas during sleeping hours. For maximum protection, a CO detector should be located outside primary sleeping areas or on each level of your home. The electrochemical sensor detects carbon monoxide, measures the concentration, and sounds a loud alarm before a potentially harmful level is reached.

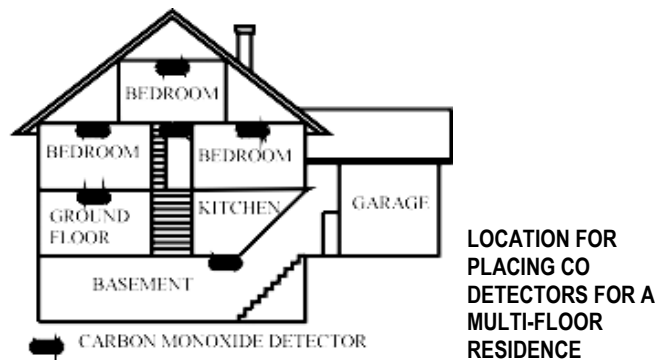

CAUTION: This detector is only intended to be ceiling mounted or no more than 12 inches below the ceiling. This detector will only indicate the presence of carbon monoxide gas at the sensor. Carbon monoxide gas may be present in other areas of the premises. The user shall actuate the test and/ or alarm reset/silence feature remotely (via an electronic signal or aerosol test gas), or by use of a person's finger or thumb, and that the use of any other instrument(s) is strictly prohibited

WARNING! This product is intended for use in ordinary indoor locations of family living units. It is not designed to measure compliance with Occupational Safety and Health Administration (OSHA) commercial or industrial standards. OSHA has established that continuous exposure levels of 50ppm should not be exceeded in an 8-hour period. Individuals with a medical problem may consider using warning devices which provide audible and visual signals for carbon monoxide concentrations under 30ppm.

For Smoke detector:

Smoke detectors should be installed in accordance with NFPA 72 (National Fire Protection Association, Batterymarch Park, Quincy, MA 02169). For complete coverage in residential

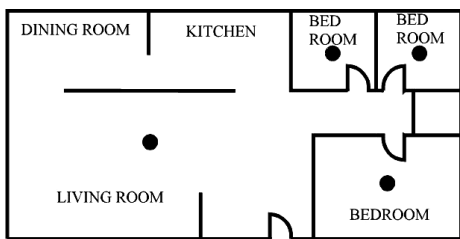

Fig. 1: One separate smoke detector in every bedroom and one on every floor as a minimum protection

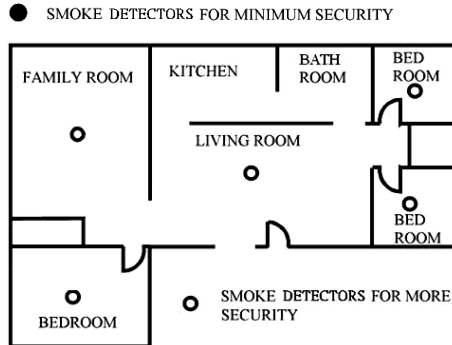

Fig. 2: One separate smoke detector in every room, except kitchen and bathroom for more security

units, smoke detectors should be installed in all rooms, halls, storage areas, basements, and attics in each family living unit. Minimum coverage is one detector on each floor and one in each sleeping area.

Some useful tips:

Install one separate smoke detector in every bedroom and one smoke detector on each floor as a minimum protection. Install one separate smoke detector in every room, except kitchen and bathroom for more security (see Fig. 1 and 2).

- Install a smoke detector on every floor of a multi-floor home or apartment, as shown in Figure 3
- Install a smoke detector inside every bedroom
- Install smoke detectors at both ends of a bedroom hallway if the hallway is more than 40 feet (12 meters) long

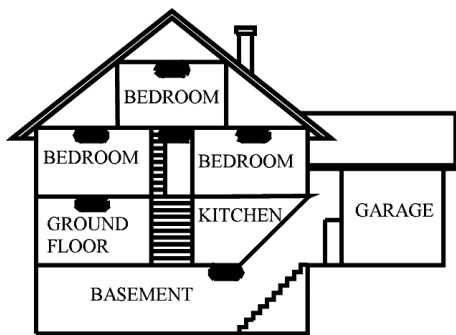

Fig. 3: Location for placing smoke detectors for a multi-floor residence.

- Install basement detectors at the bottom of the basement stairwell
- Install second-floor detectors at the top of the first-to-second floor stairwell. Be sure no door or other obstruction blocks the path of smoke to the detector
- Install additional detectors in your living room, dining room, family room, attic, utility, and storage rooms
- Install smoke detectors as close to the center of the ceiling as possible. If this is not practical, put the detector on the ceiling, no closer than 20 inches (50 cm) from any wall or corner, as shown in Figure 4
- If some of your rooms have sloped, peaked, or gabled ceilings, try to mount detectors 3 feet (0.92m) measured horizontally from the highest point of the ceiling as shown Fig. 5

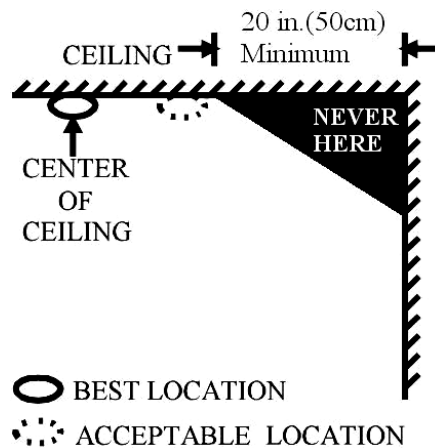

Fig. 4: Recommended best and acceptable locations to mount smoke detectors

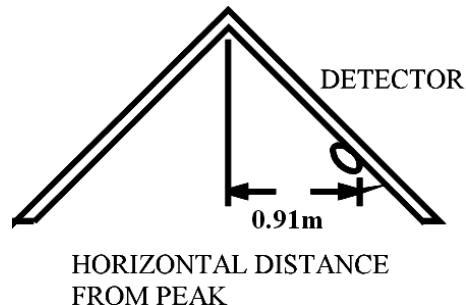

Fig. 5: Recommended location to mount smoke detectors in rooms with a sloped, gabled, or peaked ceiling

CAUTION (As required by the California State Fire Marshall): "Early warning fire detection is best achieved by the installation of fire detection equipment in all rooms and areas of the household as follows: (1) A smoke detector installed in each separate sleeping area (in the vicinity, but outside of the bedrooms), and (2) Heat or smoke detectors in the living rooms, dining rooms, bedrooms, kitchens, hallways, attics, furnace rooms, closets, utility and, storage rooms, basements and attached garages."

"For your information, the National Fire Alarm and Signaling Code, NFPA 72, reads as follows:"

"29.5.1 *Required Detection."

*29.5.1.1 Where required by applicable laws, codes, or standards for a specific type of occupancy, approved single- and multiple-station smoke detectors shall be installed as follows:

- *In all sleeping rooms and guest rooms
- *Outside of each separate dwelling unit sleeping area, within 21 ft (6.4 m) of any door to a sleeping room, the distance measured along a path of travel

On every level of a dwelling unit, including basements
On every level of a residential board and care occupancy (small facility), including basements and excluding crawl spaces and unfinished attics

- *In the living area(s) of a guest suite
- In the living area(s) of a residential board and care occupancy

(Reprinted with permission from NFPA 72®, National Fire Alarm and Signaling Code Copyright © 2012 National Fire Protection Association, Quincy, MA 02269. This reprinted material is not the complete and official position of the National Fire Protection Association, on the referenced subject which is represented only by the standard in its entirety.) (National Fire Alarm and Signaling Code® and NFPA 72® are registered trademarks of the National Fire Protection Association, Inc., Quincy, MA 02269.)

LOCATIONS NOT TO INSTALL YOUR DETECTOR

Nuisance alarms occur when detectors are installed where they will not function properly. To avoid nuisance alarms, do not install detectors in the following situations:

- Combustion particles are the by-products of burning. Therefore, do not install in or near areas where particles are present (e.g. kitchens with few windows or with poor ventilation, garages where vehicle exhaust may be present, near furnaces, hot water heaters, or space heaters)
- Do not install detectors less than 20 feet (6 meters) away from places where combustion particles are normally present. If a 20-foot distance is not possible, e.g. in a mobile home, install detector as far away from the combustion particles as possible, preferably on the wall. Provide good ventilation in such places.
- When air streams pass by kitchens, how a detector can sense combustion particles in normal air-flow paths is graphically shown in **Figure 6**, which indicates the correct and incorrect detector locations concerning this issue.
- In damp or humid areas, or near bathrooms with showers. Moist air can enter the sensing chamber, turning into droplets upon cooling, causing nuisance alarms. Install detectors at least 10ft. (3m) away from bathrooms.
- In very cold or very hot areas, including unheated buildings or outdoor rooms. If the temperature goes above or below the operating range of the detector, it will not work properly. The temperature range for your detector is 40°F to 100°F (4.4°C to 37.8°C).
- In very dusty or dirty areas, dirt and dust can build up on the detector's sensing chamber, to make it overly sensitive. Additionally, dust or dirt can block openings to the sensing chamber and keep the detector from sensing smoke.
- Near fresh air vents or very drafty areas such as near air conditioners, heaters or fans, air drafts can drive smoke away from smoke detectors.
- Dead air spaces are often at the top of a peaked roof, or in the corners between ceilings and walls. Dead air may prevent smoke from reaching a detector. See Figures 4 and 5 for recommended mounting locations.
- In insect-infested areas. If insects enter a detector's sensing chamber, they may cause a nuisance alarm. Where insects are a problem, eliminate them before installing a detector.
- Near fluorescent lights. Electrical "noise" from fluorescent lights may cause nuisance alarms. Install detectors at least 5 feet (1.5 meters) from these lights.
- Smoke detectors not to be used with smoke alarm guards.

The detector is not to be located within 5 feet (1.5m) of any cooking appliance.

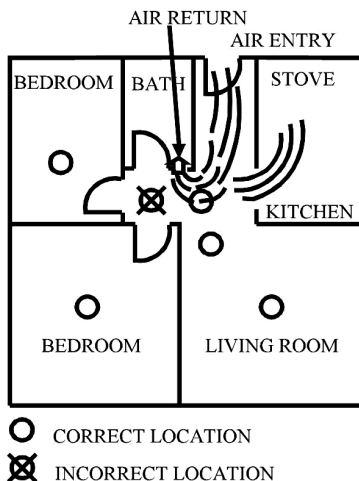

Fig. 6: Recommended detector locations to avoid air streams with combustion particles

INSTALLING YOUR DETECTOR

Read "Locations To Install Your Detector" and "Locations Not To Install Your Detector" sections in this manual first, then decide where to install a detector.

1. At the mounting location, draw a straight line six inches (15 cm) long.
2. Remove the Mounting Bracket from your detector by rotating it counterclockwise, shown in **Fig. 7**.

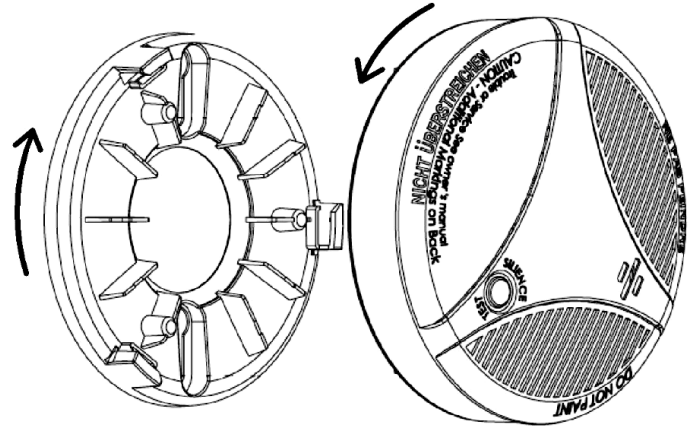

Fig. 7: Removing the Mounting Bracket

3. Place the Mounting Bracket so that the two longest hole-slots are aligned on the line drawn in step 1. In each of keyhole slots, draw a mark to locate a mounting plug and screw.
4. Remove the Mounting Bracket.
5. Using a 3/16-inch (5mm) drill bit, drill two holes at the marks and insert supplied plastic mounting anchors (if needed). **Note:** Ensure the detector is protected from dust particles created when drilling mounting holes.
6. Using two supplied screws and plastic mounting anchors, secure the Mounting Bracket to the mounting surface.
7. Battery Installation (see **Fig. 8**):
 - Open battery cover and install a fresh new battery into compartment, observing polarity (polarity is indicated by embossed markings in plastic).
 - After battery is inserted, press the **Test/Silence** button to verify detector operation. **Note:** After a battery is inserted a tamper warning will not sound until the tamper switch is pressed and released, or the detector is installed in (and removed from) the mounting base.

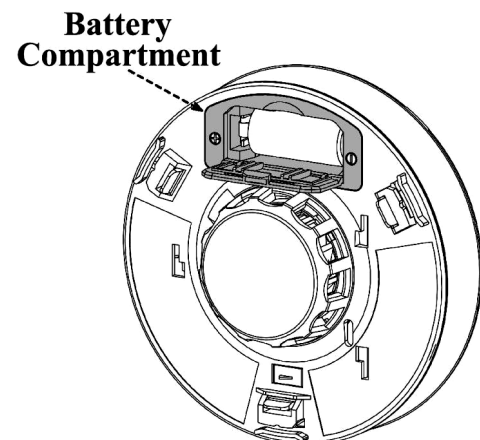

Fig. 8: Battery compartment location

8. The **GEM-SMK-CO-E** can be used as either a smoke detector or a CO detector or as a combination smoke and CO detector. Each function has a unique RF ID number; be sure to record the RF ID # for programming the correct function(s) into the respective control panel zone(s).
9. Line up the slot in the Mounting Bracket with the slot in the detector. Push the detector onto the Mounting Bracket and turn it clockwise to secure. Gently pull the detector to ensure it is securely attached to the Mounting Bracket, shown in **Fig. 9**.

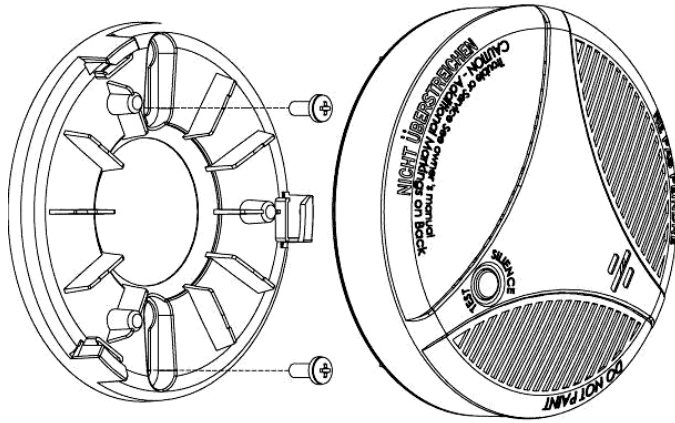

Fig. 9: Mounting the Mounting Bracket

10. Write the date of installation on the **Date of Install** label and paste it in a conspicuous location. *Replace the detector after 10 years.*

For Gemini GEM Series control panel programming, refer to the instructions included with the control panel. When using PCD-Windows Quickloader software, ensure the correct zones are selected for "FIRE ZONE" and "CARBON MONOXIDE". In addition, always perform an error check before programming.

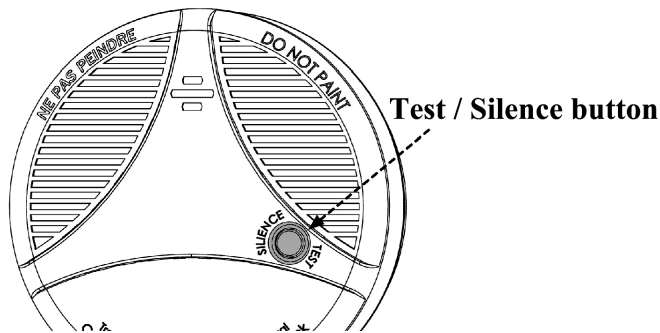

Figure 10: Test / Silence button location

WARNING SIGNALS (DETAILS)

CO ALARM: The alarm pattern is four (4) short beeps with four (4) corresponding red LED flashes every five (5) seconds for the initial four (4) minutes. After the initial four (4) minutes, this pattern will repeat every sixty (60) seconds and will repeat until the CO event is eliminated. The CO sensor is designed to detect carbon monoxide gas from ANY source of combustion; it is NOT designed to detect any other gas.

SMOKE ALARM: The alarm pattern is three (3) short alarm beeps with three (3) corresponding red LED flashes. This pattern will repeat until the smoke event is eliminated. The smoke alarm will take precedence when both smoke and CO are present.

SILENCE FEATURE: The silence feature can temporarily quiet the integral siren for several minutes, and the integral LED still flashes according to the corresponding alarm. Silence the integral siren for up to 8 minutes by pressing the **Test/Silence** button. After 8 minutes, if the smoke has not cleared, the integral siren will sound again. The CO alarm will remain silent for up to 4 minutes. After 4 minutes, if the CO levels remain dangerous, the siren will sound again. **Note:** The control panel siren will continue to sound until the arm/disarm code is entered at the control panel keypad.

TEST FEATURE: After installation, verify operation of the detector siren, LEDs, and battery by a push/release of the **Test/Silence** button at least once a month. **Note:** If the detector is set to report to the central station, temporarily suspend monitoring during the test or an alarm will be reported.

Before you begin, please note: Control panel smoke alarms take precedence over control panel CO alarms. If the panel CO alarm is tested after the smoke alarm test is initiated but not silenced, the control panel will continue to display / announce the smoke alarm, but will report the CO alarm to the central station.

Therefore, when testing the system, we recommend the CO test always be initiated first: Verify that a CO alarm is displayed at the keypad, with 4 rapid control panel sounder bursts every 5 seconds, and a CO alarm report sent to the central station. Next, the Fire alarm test should be initiated, causing a Fire alarm to be displayed at the keypad to override the CO alarm; verify that the control panel sounder sequence changes to the temporal cadence (refer to the timing diagrams in the control panel instructions), and verify that a Fire alarm report is sent to the central station.

It is suggested that the detector be tested at least annually or as required by the AHJ with UL Classified Test Gas/Spray such as Solo C6 Carbon Monoxide Test Gas and HSI Fire Smoke Check Model 25S. Remember to notify the Central Station of the test prior to starting.

Upon a press/hold of the **Test/Silence** button, the detector performs the following alarm and LED pattern test sequences:

- 3 beeps with 3 corresponding red LED flashes
- (1.5 seconds of silence)
- 4 short chirps with 4 corresponding red LED flashes
- (5 seconds of silence)
- 4 short chirps with 4 corresponding red LED flashes

The above pattern test sequences constitute one test "cycle". Each test 'cycle' takes about 13 seconds to complete and continues while the **Test/Silence** button is pressed and held down. A smoke or CO test alarm transmission is sent to the control panel at the end of the 'cycle' as indicated on the keypad display.

Test the control panel CO alarm programming:

Press/hold the **Test/Silence** button and release it any time after the 3 beeps in the second 'cycle';

--OR--

Press/hold the **Test/Silence** button for more than 16 seconds.

Test the control panel smoke alarm programming:

Press/hold the **Test/Silence** button and release any time

(continued)

SUMMARY OF WARNING SIGNALS

Press/release the **Test/Silence** button to temporarily silence any warning signal. See pages 6-7 for details. (*Normal operation = green LED flashes once every 50 seconds*).

- 4 beeps with 4 red LED flashes every 5 seconds (for the initial 4 minutes) = **CO ALARM**
- 3 beeps with 3 red LED flashes = **SMOKE ALARM**
- 2 beeps with 2 yellow LED flashes every 50 seconds = **SMOKE CLEAN ME**
- 2 beeps with 1 yellow LED flash every 50 seconds = **SMOKE LOW SENSITIVITY** (replace detector)
- 1 beep with 4 yellow LED flashes every fifty 50 seconds = **END OF PRODUCT LIFE**
- 2 long beeps with 2 yellow LED flashes = **TAMPER ALARM**
- 1 beep with 1 yellow LED flash every 50 seconds = **LOW BATTERY** (cannot be silenced)
- 1 beep with 2 yellow LED flashes every 50 seconds = **CO TROUBLE** (replace detector)
- 3 beeps with 1 yellow LED flash every 50 seconds = **SMOKE TROUBLE** (replace detector)

between first 3 beeps and second 4 short chirps in the first 'cycle';

--OR--

Press/hold the **Test/Silence** button for 5 - 10 seconds.

SMOKE CLEAN ME WARNING: This pattern is two (2) beeps with two (2) corresponding yellow LED flashes every 50 seconds. Refer to **GENERAL MAINTENANCE** section for detector cleaning instructions.

SMOKE LOW SENSITIVITY WARNING: This pattern is two (2) beeps with one (1) corresponding yellow LED flash every 50 seconds. This pattern indicates the detector must be replaced.

HUSH FEATURE: Temporarily quiet the siren for one hour (the LED still flashes according to the corresponding alarm or warning signal pattern). You can silence or restore warning signals by pressing the **Test/Silence** button (the Low Battery warning cannot be silenced).

END OF PRODUCT LIFE WARNING: When the detector sounds one (1) beep with four (4) corresponding yellow LED flashes every fifty (50) seconds, the detector must be replaced immediately. The end-of-life duration is ten (10) years, starting when the detector is first placed into operation.

TAMPER ALARM: When the detector is removed from its Mounting Bracket, the tamper switch is opened, sounding the tamper alarm. The tamper switch location is shown in **Figure 11**. The tamper alarm pattern is two (2) long alarm beeps with two (2) corresponding yellow LED flashes. **WARNING:**

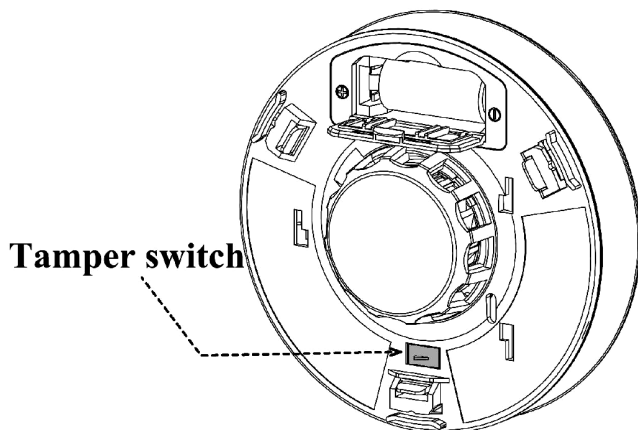

Figure 11: Tamper switch location

For 5 minutes after the unit is powered (e.g. after a battery installation or change), a tamper warning will not sound and the transmitter will not send a tamper signal to the supervised receiver. After this initial 5 minutes the tamper warning will sound and will be active thereafter.

LOW BATTERY WARNING: When the batteries are low and need to be replaced, the device will beep and the yellow LED light will flash once every 50 seconds. This warning should last for up to 30 days but be sure to replace the battery as soon as possible before the battery is completely exhausted.

CO TROUBLE WARNING: This pattern is one (1) siren beep with two (2) corresponding flashes of the yellow LED every 50 seconds. This pattern indicates the detector must be replaced.

SMOKE TROUBLE WARNING: This pattern is three (3) beeps with one (1) corresponding yellow LED flash every 50 seconds. This pattern indicates the detector must be replaced.

GENERAL MAINTENANCE

To keep your detector in good working order, perform the following steps. Verify alarm siren, LED lights, and battery operation by pushing the **Test/Silence** button at least once every week. To remove dust and dirt, remove the device from its Mounting Bracket (after contacting the central station to warn them of the tamper alarm caused by the Mounting Bracket removal) and vacuum the detector cover and vents with a soft brush attachment once every month. Reinstall detector immediately after cleaning and then test using the **Test/Silence** button.

Never attempt to disassemble the detector or clean inside it as this will void your warranty. Never use detergents or solvents to clean the detector. When household cleaning supplies or similar contaminants are used, be sure the area is well ventilated. The following substances can damage the sensor and may cause false readings: Methane, propane, isobutene, isopropanol, ethyl acetate, hydrogen sulfide, sulfide dioxides, alcohol based products, paints, thinners, solvents, adhesives, hair spray, after shave, perfumes, and some cleaning agents. Do not paint the detector as paint will seal the vents and interfere with its ability to detect smoke. Move the detector prior to performing any of the following: Staining or stripping wood, painting, wall papering or using adhesives. Store the detector in a plastic bag during any of these activities to help protect the sensor from damage. Be sure to reinstall the detector afterwards to ensure continuous protection.

IF CO ALARM ACTIVATES

WARNING!! Actuation of the CO alarm indicates the presence of carbon monoxide (CO) which can KILL YOU. If CO is detected, perform the following steps. *Thoroughly familiarize yourself with these items and review them with all family members.*

- Press the **Test/Silence** button.
Call your emergency services telephone number, i.e. fire department.
- Immediately move to fresh air -- outdoors or by an open door/window. Perform a head count to check that all persons are accounted for. Do not reenter the premises or move away from fresh air until the emergency responders have arrived and the premises has been completely aired out (0% carbon monoxide detected), and your detector returns to its normal condition.
- After performing steps 1 - 3, if your detector reactivates within a 24 hour period, repeat steps 1 - 3 and telephone a qualified appliance technician to investigate for sources of CO from fuel burning equipment and appliances, and inspect for proper operation of this equipment. If problems are identified during this inspection, repair the equipment immediately. Note any combustion equipment not inspected by the technician and consult the manufacturers' instructions, or contact the manufacturers directly, for more information about CO safety and the equipment. Be sure that motor vehicles are not, and have not been, operating in an attached garage or adjacent to the residence.

ACTIONS TO TAKE AFTER THE PROBLEM IS CORRECTED

After the CO gas presence has been corrected, the CO alarm will turn off. After waiting for 10 minutes, press and hold the **Test/Silence** button to test the CO detector to ensure that it is working properly again.

IF SMOKE ALARM ACTIVATES

Never ignore the sound of the alarm. Check for signs of fire or smoke throughout the premises. If smoke is discovered, follow the steps list below. *Thoroughly familiarize yourself with these items and review them with all family members.*

Smoke alarms may not awaken all sleeping individuals. It is the responsibility of those who can assist others to help those who may not be awakened by the alarm sound, or to those who may be incapable of safely evacuating the area unassisted. Leave immediately using one of your pre-planned escape routes. Every second counts. Do not get dressed or pick up valuables.

Before opening inside doors, look for smoke seeping in around the door edges. Feel the door with your hand. If the door is hot, try to use another exit. If you feel it is safe, open the door very slowly but be prepared to close it quickly should smoke rush in.

If your escape route requires you to go through smoke, crawl low and under the smoke where the air is clearer.

Go to your predetermined meeting place. When two people have arrived, one should leave to call emergency responders from a neighbor's home. The other should stay to perform a head count.

Do not reenter the premises under any circumstances until the authorities give you permission.

LIMITATIONS OF WIRELESS DEVICES

In planning the layout of the system, give careful consideration to the location of the Transmitter(s) and Receiver(s). Regardless of where the control panel is mounted, the receiver should be centrally located within the premises (whenever possible), that is, equally distant from all transmitters. Typical unobstructed range is up to 1000 ft.

Choose a location as high above ground level as practical (attic installations are not recommended due to temperatures exceeding the specification of the receiver), keeping in mind that metal objects may adversely affect reception. Also keep in mind construction materials in use that could affect wireless performance. Although wood and wallboard construction will have little effect upon signal strength at the receiver, concrete or brick can reduce signal strength by up to 35%, while steel-reinforced concrete or metal lath and plaster can reduce transmitter strength by as much as 90%. Where necessary additional receivers may be required.

See the receiver installation instructions for minimum signal strength for installation.

Please read the **NAPCO Limited Warranty**
in our Technical Library
(<https://tech.napcosecurity.com/>)
at the following link:

https://tech.napcosecurity.com/index.php/techlibrary/docdetails/brand_id/1/doc_id/3224

THE FOLLOWING STATEMENT IS REQUIRED BY THE FCC.

This equipment has been tested and found to comply with the limits for a Class B digital device, pursuant to Part 15 of the FCC Rules. These limits are designed to provide reasonable protection against harmful interference in a residential installation. This equipment generates uses and can radiate radio frequency energy and, if not installed and used in accordance with the instructions, may cause harmful interference to radio communications. However, there is no guarantee that interference will not occur in a particular installation. If this equipment does cause harmful interference to radio or television reception, which can be determined by turning the equipment off and on, the user is encouraged to try to correct the interference by one of the following measures:

Reorient or relocate the receiving antenna.

Increase the separation between the equipment and receiver.

Connect the equipment into an outlet on a circuit different from that to which the receiver is connected.

Consult the dealer or an experienced radio/TV technician for help.

Changes or modifications not expressly approved by the party responsible for compliance could void the user's authority to operate the equipment

This device complies with part 15 of the FCC Rules. Operation is subject to the following two conditions: (1) This device may not cause harmful interference, and (2) this device must accept any interference received, including interference that may cause undesired operation.