



Engineering Solutions & Electromagnetic Compatibility Services

**Certification Application Report  
FCC Part 15.247**

<b>Test Lab</b> Rhein Tech Laboratories, Inc. Phone: 703-689-0368 360 Herndon Parkway Fax: 703-689-2056 Suite 1400 www.rheintech.com Herndon, VA 20170 E-Mail: atcbinfo@rheintech.com		<b>Applicant</b> Motorola, Inc. Phone: 215-323-1000 101 Tournament Drive Horsham, PA 19044 (USA) Contact: Mike Welty E-Mail: michael.welty@arrisi.com	
<b>FCC ID</b>	ACQ-XG1	<b>Test Report Date</b>	June 4, 2013
		<b>RTL Work Order Number</b>	2013092
<b>Model</b>	XG1	<b>RTL Quote Number</b>	QRTL13-092A
<b>American National Standard Institute</b>	ANSI C63.4-2009: Methods of Measurement of Radio-Noise Emissions from Low-Voltage Electrical and Electronic Equipment in the Range of 9 kHz to 40 GHz		
<b>FCC Classification</b>	DTS – Part 15 Digital Transmission System		
<b>FCC Rule Part</b>	FCC Rules Part 15.247 (10-01-12): Operation within the bands 920-928 MHz, 2400-2483.5 MHz and 5725-5850 MHz Direct Sequence System		
<b>Digital Interface Information</b>	Digital Interface was found to be compliant		
<b>Frequency Range (MHz)</b>	<b>Output Power (W)*</b>	<b>Frequency Tolerance</b>	<b>Emission Designator</b>
2425-2475	0.0008	N/A	N/A

\*power reported is maximum peak conducted power

I, the undersigned, hereby declare that the equipment tested and referenced in this report conforms to the identified standard(s) as described in this test report. No modifications were made to the equipment during testing in order to achieve compliance with these standards. Furthermore, there was no deviation from, additions to, or exclusions from, the applicable parts of FCC Part 2, FCC Part 15 and ANSI C63.4.

Signature: 

Date: June 4, 2013

Typed/Printed Name: Desmond A. Fraser

Position: President

*This report may not be reproduced, except in full, without the written approval of Rhein Tech Laboratories, Inc. and Motorola, Inc. The test results relate only to the item(s) tested.*

*These tests are accredited and meet the requirements of ISO/IEC 17025 as verified by ANSI-ASQ National Accreditation Board/ACLASS. Refer to certificate and scope of accreditation AT-1445.*

## Table of Contents

---

1	General Information .....	5
1.1	Scope .....	5
1.2	Description of EUT .....	5
1.3	Test Facility .....	5
1.4	Related Submittal(s)/Grant(s) .....	5
1.5	Modifications .....	5
2	Test Information .....	6
2.1	Description of Test Modes .....	6
2.2	Exercising the EUT .....	6
2.3	Test Results Summary .....	6
2.4	Test System Details .....	7
2.5	Configuration of Tested System .....	8
3	Peak Output Power - 15.247(b)(3) .....	9
3.1	Power Output Test Procedure .....	9
3.2	Power Output Test Data .....	9
4	Duty Cycle Measurement .....	10
4.1	Duty Cycle Test Procedure .....	10
4.2	Duty Cycle Test Results .....	10
5	Compliance with the Band Edge – FCC 15.247(d) .....	12
5.1	Band Edge Test Procedure .....	12
5.2	Restricted Band Edge Test Results .....	13
5.2.1	Calculation of Lower Band Edge .....	13
5.2.2	Calculation of Upper Band Edge .....	14
6	Antenna Conducted Spurious Emissions - 15.247(d) .....	15
6.1	Antenna Conducted Spurious Emissions Test Procedures .....	15
6.2	Antenna Conducted Spurious Emissions Test Results .....	15
7	6 dB Bandwidth - 15.247(a)(2) .....	16
7.1	6 dB Bandwidth Test Procedure – Minimum 6 dB Bandwidth .....	16
7.2	6 dB Bandwidth Test Results .....	16
8	Power Spectral Density – FCC 15.247(e) .....	20
8.1	Power Spectral Density Test Procedure .....	20
8.2	Power Spectral Density Test Data .....	20
9	Conducted Emissions Measurement Limits – FCC 15.207 .....	24
9.1	Limits of Conducted Emissions Measurement .....	24
9.2	Site and Test Description .....	24
9.3	Conducted Emissions Test Data .....	25
10	Radiated Emissions - FCC 15.209, 15.205 .....	27
10.1	Radiated Emissions Measurement Test Procedure .....	27
10.2	Radiated Emissions Test Results .....	29
10.2.1	Radiated Emissions Harmonics/Spurious Test Data .....	29
11	Conclusion .....	31

---

### Figure Index

---

Figure 2-1: Configuration of System Under Test.....	8
---	---

---

### Table Index

---

Table 2-1: Frequencies Tested .....	6
Table 2-2: Test Results Summary – FCC Part 15, Subpart C (Section 15.247).....	6
Table 2-3: Equipment Under Test .....	7
Table 3-1: Power Output Test Equipment .....	9
Table 3-2: Power Output Test Data.....	9
Table 4-1: Duty Cycle Test Equipment.....	11
Table 5-1: Band Edge Test Equipment .....	12
Table 6-1: Antenna Conducted Spurious Test Equipment.....	15
Table 7-1: 6 dB Bandwidth Test Equipment.....	16
Table 7-2: 6 dB Bandwidth Test Data .....	16
Table 8-1: Power Spectral Density Test Equipment .....	20
Table 8-2: Power Spectral Density Test Data .....	20
Table 9-1: Conducted Emissions Test Equipment .....	24
Table 10-1: Radiated Emissions Test Equipment .....	28
Table 10-2: Radiated Emissions Harmonics/Spurious (2425 MHz) Average .....	29
Table 10-3: Radiated Emissions Harmonics/Spurious (2425 MHz) Peak.....	29
Table 10-4: Radiated Emissions Harmonics/Spurious (2450 MHz) Average .....	29
Table 10-5: Radiated Emissions Harmonics/Spurious (2450 MHz) Peak.....	30
Table 10-6: Radiated Emissions Harmonics/Spurious (2475 MHz) Average .....	30
Table 10-7: Radiated Emissions Harmonics/Spurious (2475 MHz) Peak.....	30

---

### Plot Index

---

Plot 4-1: Duty Cycle in 100ms .....	10
Plot 4-2: Duty Cycle Pulse Width.....	11
Plot 5-1: Lower Band Edge (2425 MHz).....	13
Plot 5-2: Upper Band Edge (2475 MHz).....	14
Plot 7-1: 6 dB Bandwidth (2425 MHz) .....	17
Plot 7-2: 6 dB Bandwidth (2450 MHz) .....	18
Plot 7-3: 6 dB Bandwidth (2475 MHz) .....	19
Plot 8-1: Power Spectral Density (2425 MHz) .....	21
Plot 8-2: Power Spectral Density (2450 MHz) .....	22
Plot 8-3: Power Spectral Density (2475 MHz) .....	23
Plot 9-1: Conducted Emissions Test Data – Neutral - RX Mode.....	25
Plot 9-2: Conducted Emissions Test Data – Hot – RX Mode .....	25
Plot 9-3: Conducted Emissions Test Data – Neutral - TX Mode .....	26
Plot 9-4: Conducted Emissions Test Data – Hot – TX Mode .....	26

---

### Appendix Index

---

Appendix A: FCC Part 1.1307, 1.1310, 2.1091, 2.1093 .....	32
Appendix B: Agency Authorization Letter .....	33
Appendix C: FCC Confidentiality Request Letter.....	34
Appendix D: ID Label and Label Location .....	35
Appendix E: Technical Operational Description .....	37
Appendix F: Schematics.....	38
Appendix G: Block Diagram .....	39
Appendix H: Manual.....	40
Appendix I: Test Photographs .....	41
Appendix J: External Photographs.....	45
Appendix K: Internal Photographs .....	48

---

### Photograph Index

---

Photograph 1: ID Label Sample .....	35
Photograph 2: ID Label Location .....	36
Photograph 3: Radiated Emissions Testing – Front View .....	41
Photograph 4: Radiated Emissions Testing – Back View.....	42
Photograph 5: Conducted Emissions Testing – Front View .....	43
Photograph 6: Conducted Emissions Testing – Back View.....	44
Photograph 7: Front View .....	45
Photograph 8: Rear View.....	46
Photograph 9: Bottom .....	47
Photograph 10: Top View without Cover .....	48
Photograph 11: HDD Removed .....	49
Photograph 12: Bezel PWB Front.....	50
Photograph 13: Bezel PWB Rear .....	51
Photograph 14: RF4CE Circuit Antenna .....	52

## 1 General Information

### 1.1 Scope

Applicable Standards:

FCC Rules Part 15.247 (10-01-12): Frequency Hopping, Direct Spread Spectrum and Hybrid Systems that are in operation within the bands of 902-928 MHz, 2400-2483.5 MHz and 5725-5850 MHz.

### 1.2 Description of EUT

<b>Equipment Under Test</b>	Set Top Box
<b>Model</b>	XG1
<b>Power Supply</b>	AC Adapter (12VDC 3A output)
<b>Frequency Range</b>	2425 – 2475 MHz
<b>Antenna Connector Type</b>	Internal
<b>Antenna Types</b>	Inverted F Trace 3 dBi

### 1.3 Test Facility

The open area test site and conducted measurement facility used to collect the radiated data is located at 360 Herndon Parkway, Suite 1400, Herndon, Virginia 20170. This site has been fully described in a report and approved by the Federal Communications Commission to perform AC line conducted and radiated emissions testing (ANSI C63.4 2003).

### 1.4 Related Submittal(s)/Grant(s)

This is an original FCC certification application for Motorola, Inc. Model XG1, FCC ID: ACQ-XG1.

### 1.5 Modifications

No modifications were required.

## 2 Test Information

### 2.1 Description of Test Modes

In accordance with FCC 15.31(m), and because the EUT utilizes an operating band greater than 10 MHz, the following frequencies were tested:

**Table 2-1: Frequencies Tested**

Frequency (MHz)
2425
2450
2475

### 2.2 Exercising the EUT

The EUT was tested in all three orthogonal planes in order to determine worst-case emissions. The EUT was provided with software to continuously transmit during testing. The carrier was also checked to verify that information was being transmitted. There were no deviations from the test standard(s) and/or methods. The test results reported relate only to the item tested.

### 2.3 Test Results Summary

**Table 2-2: Test Results Summary – FCC Part 15, Subpart C (Section 15.247)**

Standards	Test	Pass/Fail or N/A
FCC 15.207	AC Power Conducted Emissions	Pass
FCC 15.209, 15.205	Radiated Emissions	Pass
FCC 15.247(a)(2)	6 dB Bandwidth	Pass
15.247(b)(3)	Maximum Peak Power Output	Pass
FCC 15.247(d)	Antenna Conducted Spurious Emissions	Pass
FCC 15.247(e)	Power Spectral Density	Pass
FCC 15.247(d)	Band Edge Measurement	Pass

## 2.4 Test System Details

The test samples were received on May 14, 2013. The FCC identifiers for all applicable equipment, plus descriptions of all cables used in the tested system, are identified in the following tables.

**Table 2-3: Equipment Under Test**

Part	Manufacturer	Model	Serial Number	FCC ID	Cable Description	RTL Bar Code
Set Top Box with Internal DSSS transmitter	Motorola, Inc.	XG1	XX00B 0DB010794101 310841235	ACQ-XG1	N/A	21042
Set Top Box with Internal DSSS transmitter	Motorola, Inc.	XG1	XX00B 0DB010857101 314040248	ACQ-XG1	N/A	21071
Remote Control	Motorola, Inc.	RF4CE	N/A	N/A	N/A	21044
Remote Control	Motorola, Inc.	XR2	N/A	TX4CRB29A	N/A	21069
12VDC/AC Adapter	Delta Electronics	EADP-40MB A	DUTD24T011D	N/A	1.9m unshielded DC with ferrite/1.9m unshielded AC	21043

## 2.5 Configuration of Tested System

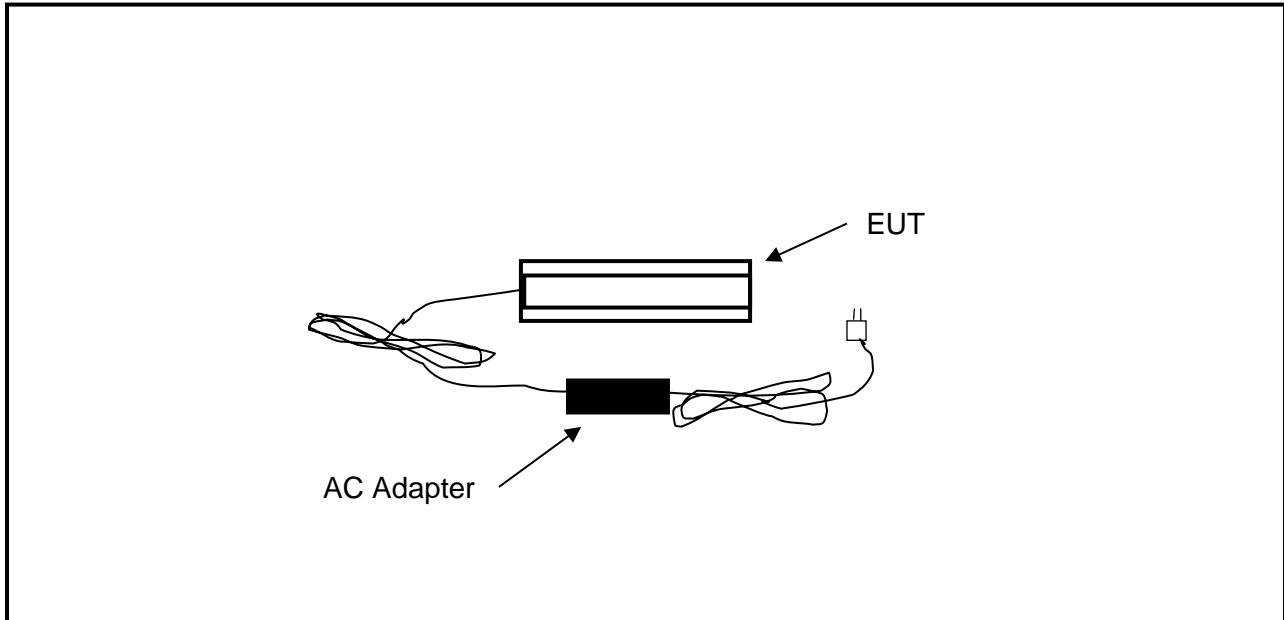

Figure 2-1: Configuration of System Under Test



### 3 Peak Output Power - 15.247(b)(3)

#### 3.1 Power Output Test Procedure

A conducted power measurement of the EUT was taken.

**Table 3-1: Power Output Test Equipment**

RTL Asset #	Manufacturer	Model	Part Type	Serial Number	Calibration Due Date
901583	Agilent Technologies	N9010A	EXA Signal Analyzer (10 Hz - 26.5 GHz)	MY51250846	4/16/14

#### 3.2 Power Output Test Data

**Table 3-2: Power Output Test Data**

Frequency (MHz)	Peak Power Conducted Output (dBm)
2425	-0.9
2450	-1.0
2475	-1.0

#### Test Personnel:

Daniel Baltzell  
 Test Engineer

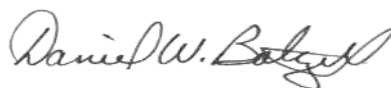

Signature

May 21, 2013  
 Date of Test

## 4 Duty Cycle Measurement

### 4.1 Duty Cycle Test Procedure

The analyzer display captured a pulse in 100ms using a video trigger on a normally operated EUT using a remote control to obtain the pulse. A single pulse was centered and the width displayed with a delta marker. The results are used to calculate an average value from the peak emission using the formula  $20\text{Log}(\text{pulse width}/100\text{ms})$ .

### 4.2 Duty Cycle Test Results

Plot 4-1: Duty Cycle in 100ms

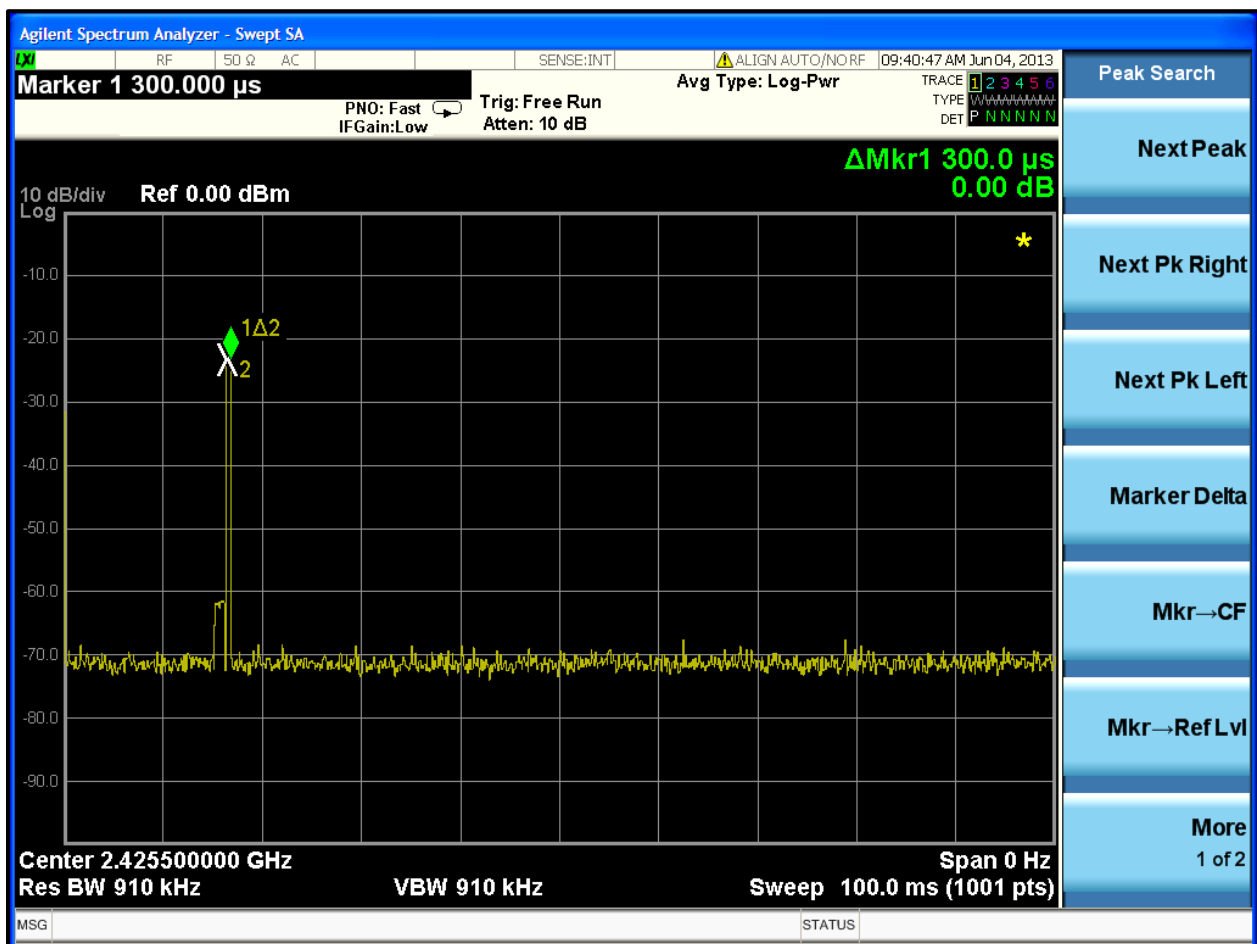

**Plot 4-2: Duty Cycle Pulse Width**

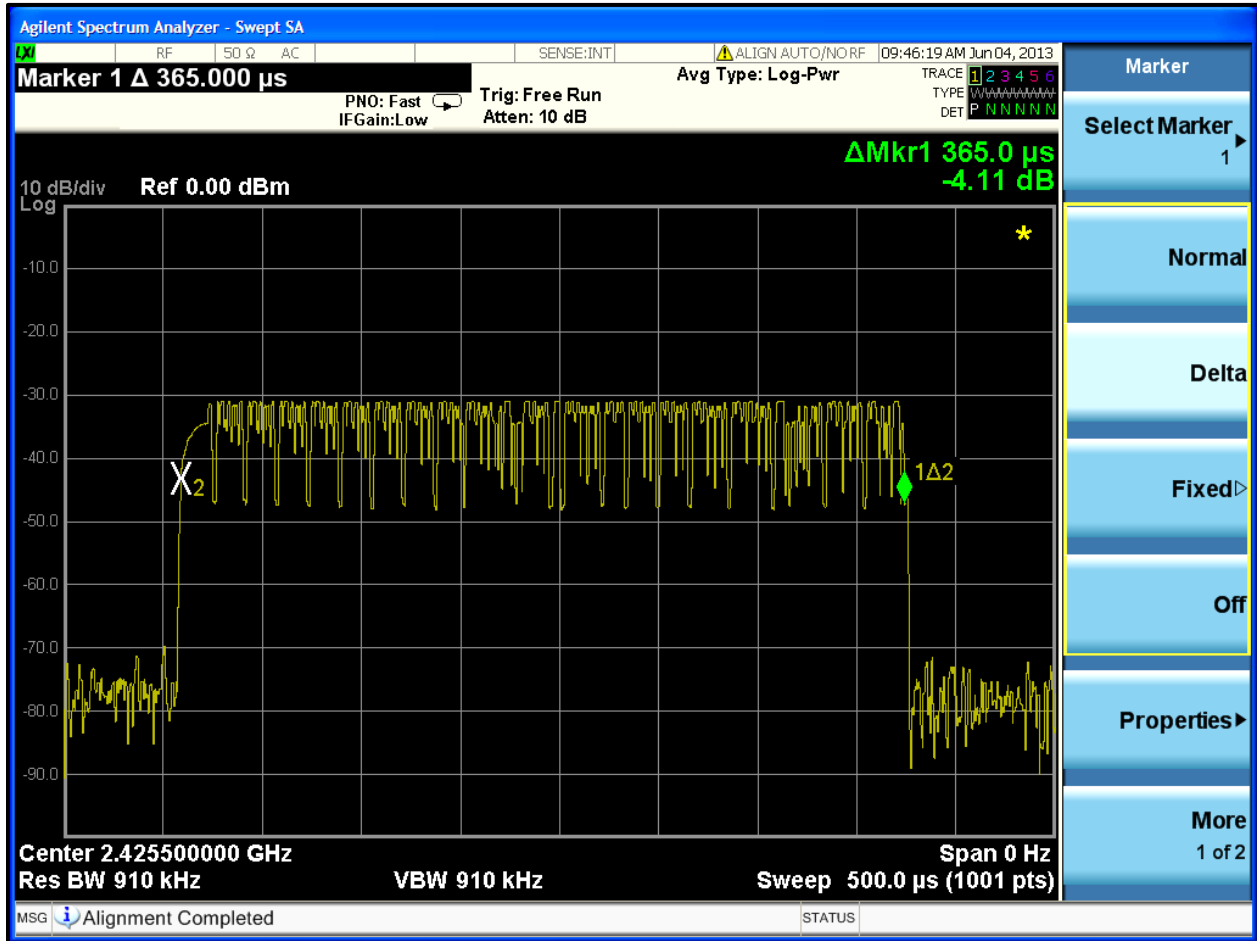

Calculation:  $20 \text{ Log} (0.365\text{ms}/100\text{ms}) = -48.8 \text{ dB}$

**Table 4-1: Duty Cycle Test Equipment**

RTL Asset #	Manufacturer	Model	Part Type	Serial Number	Calibration Due Date
901583	Agilent Technologies	N9010A	EXA Signal Analyzer (10 Hz - 26.5 GHz)	MY51250846	4/16/14

**Test Personnel:**

Daniel Baltzell  
 Test Engineer

Signature

June 4, 2013  
 Date of Test

## 5 Compliance with the Band Edge – FCC 15.247(d)

### 5.1 Band Edge Test Procedure

The transmitter output was connected to its appropriate antenna. Peak (1 MHz RBW/VBW) and average (1 MHz RBW/10 Hz VBW) radiated measurements were taken with a suitable span to encompass the peak of the fundamental. A delta measurement was performed from the highest peak in the restricted band to the peak of the fundamental, and subtracted from the field strength; the result was compared to the limit in the restricted band (54 dBuV/m).

**Table 5-1: Band Edge Test Equipment**

RTL Asset #	Manufacturer	Model	Part Type	Serial Number	Calibration Due Date
901242	Rhein Tech Laboratories	WRT-000-0003	Wood Rotating Table	N/A	Not Required
900772	EMCO	3161-02	Horn Antenna (2 - 4 GHz)	9804-1044	4/19/14
901215	Hewlett Packard	8596EM	Spectrum Analyzer (9 kHz - 12.8 GHz)	3826A00144	3/15/14
900878	Rhein Tech Laboratories	AM3-1197-0005	3 meter antenna mast, polarizing	Outdoor Range 1	Not Required
900932	Hewlett Packard	8449B OPT H02	Preamplifier (1 - 26.5 GHz)	3008A00505	8/10/13
900878	Rhein Tech Laboratories	AM3-1197-0005	3 meter antenna mast, polarizing	Outdoor Range 1	Not Required
901583	Agilent Technologies	N9010A	EXA Signal Analyzer (10 Hz - 26.5 GHz)	MY51250846	4/16/14

## 5.2 Restricted Band Edge Test Results

### 5.2.1 Calculation of Lower Band Edge

54.3 dBuV/m is the field strength measurement, from which the delta measurement of 58.1 dB is subtracted (reference plots), resulting in a level of -3.8 dB. This level has a margin of 57.8 dB below the limit of 54 dBuV/m.

Calculation:  $54.3 \text{ dBuV/m} - 58.1 \text{ dB} - 54 \text{ dBuV/m} = -57.8 \text{ dB}$

Peak Field Strength of Lower Band Edge (1 MHz RBW/3 MHz VBW) = 103.1 dBuV/m  
 Average Field Strength of Lower Band Edge (1 MHz RBW/10 Hz VBW) = 54.3 dBuV/m  
 Delta measurement = 58.1 dB

**Plot 5-1: Lower Band Edge (2425 MHz)**

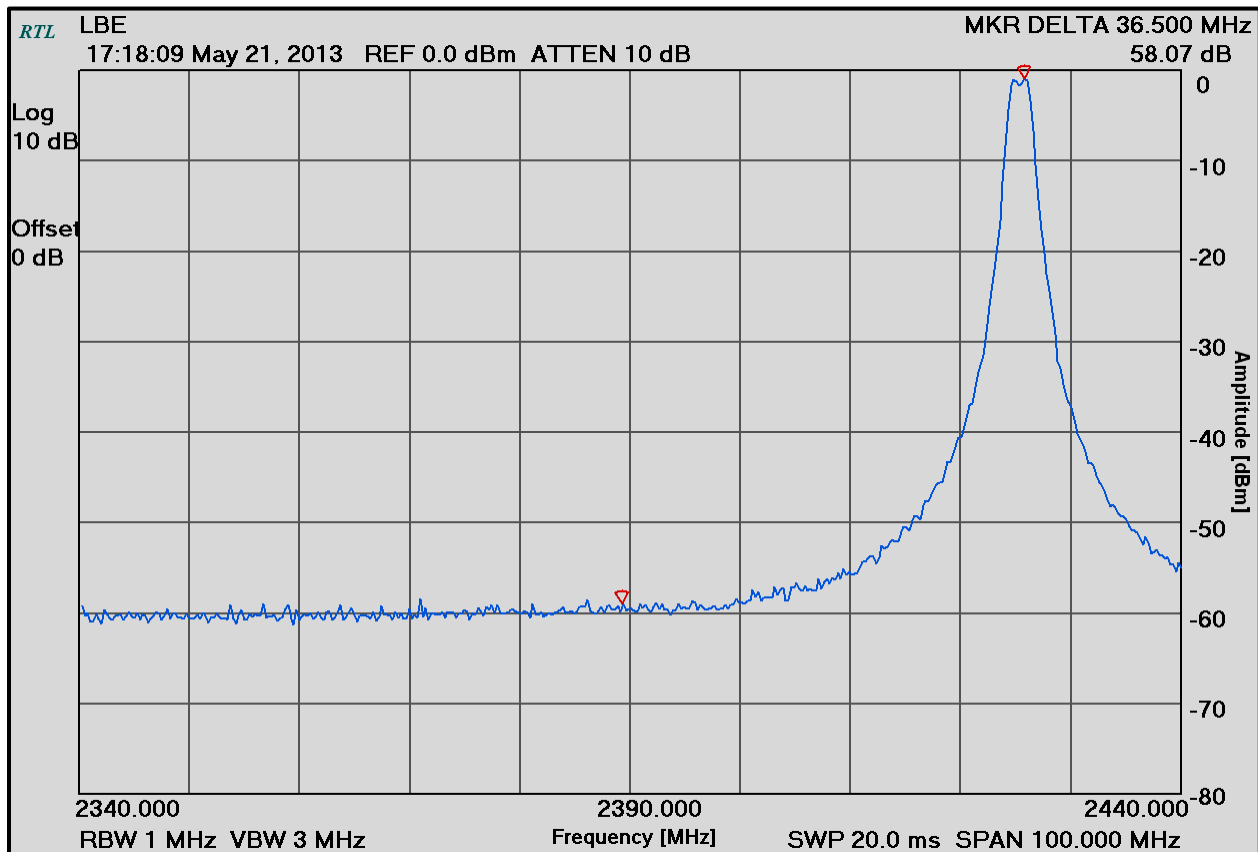

### 5.2.2 Calculation of Upper Band Edge

54.1 dBuV/m is the field strength measurement, from which the delta measurement of 49 dB is subtracted (reference plot), resulting in a level of 5.1 dB. This level has a margin of 48.9 dB below the limit of 54 dBuV/m.

Calculation:  $54.1 \text{ dBuV/m} - 49 \text{ dB} - 54 \text{ dBuV/m} = -48.9 \text{ dB}$

Peak Field Strength of Upper Band Edge (1 MHz RBW/3 MHz VBW) = 102.9dBuV/m  
 Average Field Strength of Upper Band Edge (1 MHz RBW/10 Hz VBW) = 54.1 dBuV/m  
 Delta measurement = 49 dB

**Plot 5-2: Upper Band Edge (2475 MHz)**

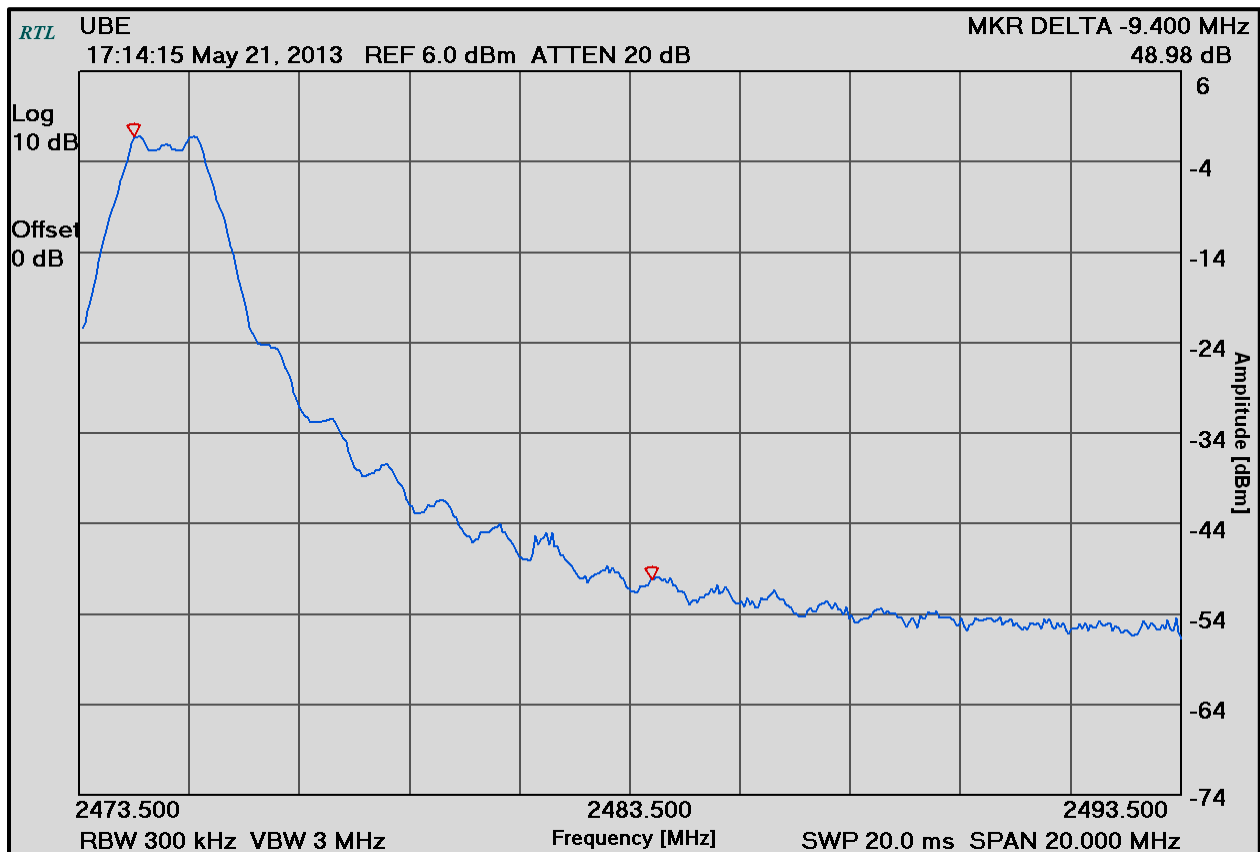

**Test Personnel:**

Daniel Baltzell  
 Test Engineer

Signature

May 21, 2013  
 Date of Test

## 6 Antenna Conducted Spurious Emissions - 15.247(d)

### 6.1 Antenna Conducted Spurious Emissions Test Procedures

Antenna spurious emissions per FCC 15.247(d) were measured from the EUT antenna port using a 50 ohm spectrum analyzer with the resolution bandwidth set at 100 kHz, and the video bandwidth set at 100 kHz. The modulated carrier was identified at the following frequencies: 2425 MHz, 2450 MHz and 2475 MHz.

### 6.2 Antenna Conducted Spurious Emissions Test Results

No harmonics or spurs were found within 20 dB (note that we are reporting power as peak) of the limit from the carrier to the 10<sup>th</sup> harmonic of the carrier frequency. Per FCC 15.31(o), no data is being reported.

**Table 6-1: Antenna Conducted Spurious Test Equipment**

RTL Asset #	Manufacturer	Model	Part Type	Serial Number	Calibration Due Date
901215	Hewlett Packard	8596EM	Spectrum Analyzer (9 kHz - 12.8 GHz)	3826A00144	3/15/14
901583	Agilent Technologies	N9010A	EXA Signal Analyzer (10 Hz - 26.5 GHz)	MY51250846	4/16/14

#### Test Personnel:

Daniel Baltzell  
Test Engineer

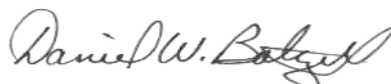

Signature

May 21, 2013  
Date of Test

**7 6 dB Bandwidth - 15.247(a)(2)**

**7.1 6 dB Bandwidth Test Procedure – Minimum 6 dB Bandwidth**

The minimum 6 dB bandwidths per FCC 15.247(a)(2) were measured using a 50 ohm spectrum analyzer with the resolution bandwidth set at 100 kHz, and the video bandwidth set at 300 kHz. The device was modulated. The minimum 6 dB bandwidths are presented below.

**Table 7-1: 6 dB Bandwidth Test Equipment**

RTL Asset #	Manufacturer	Model	Part Type	Serial Number	Calibration Due Date
901215	Hewlett Packard	8596EM	Spectrum Analyzer (9 kHz - 12.8 GHz)	3826A00144	3/15/14

**7.2 6 dB Bandwidth Test Results**

**Table 7-2: 6 dB Bandwidth Test Data**

Frequency (MHz)	6 dB Bandwidth (MHz)	Minimum Limit (MHz)	Pass/Fail
2425	1.63	0.5	Pass
2450	1.63	0.5	Pass
2475	1.68	0.5	Pass



**Plot 7-1: 6 dB Bandwidth (2425 MHz)**

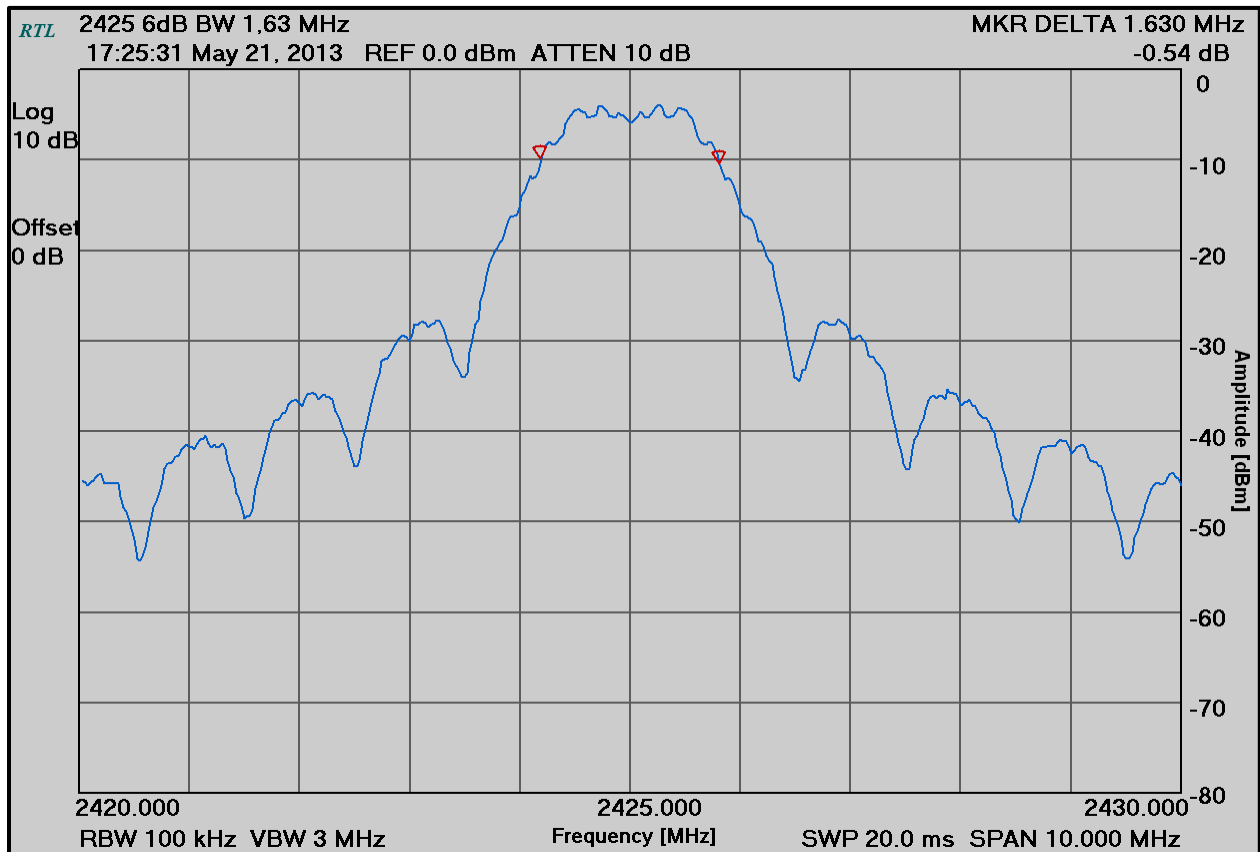

**Plot 7-2: 6 dB Bandwidth (2450 MHz)**

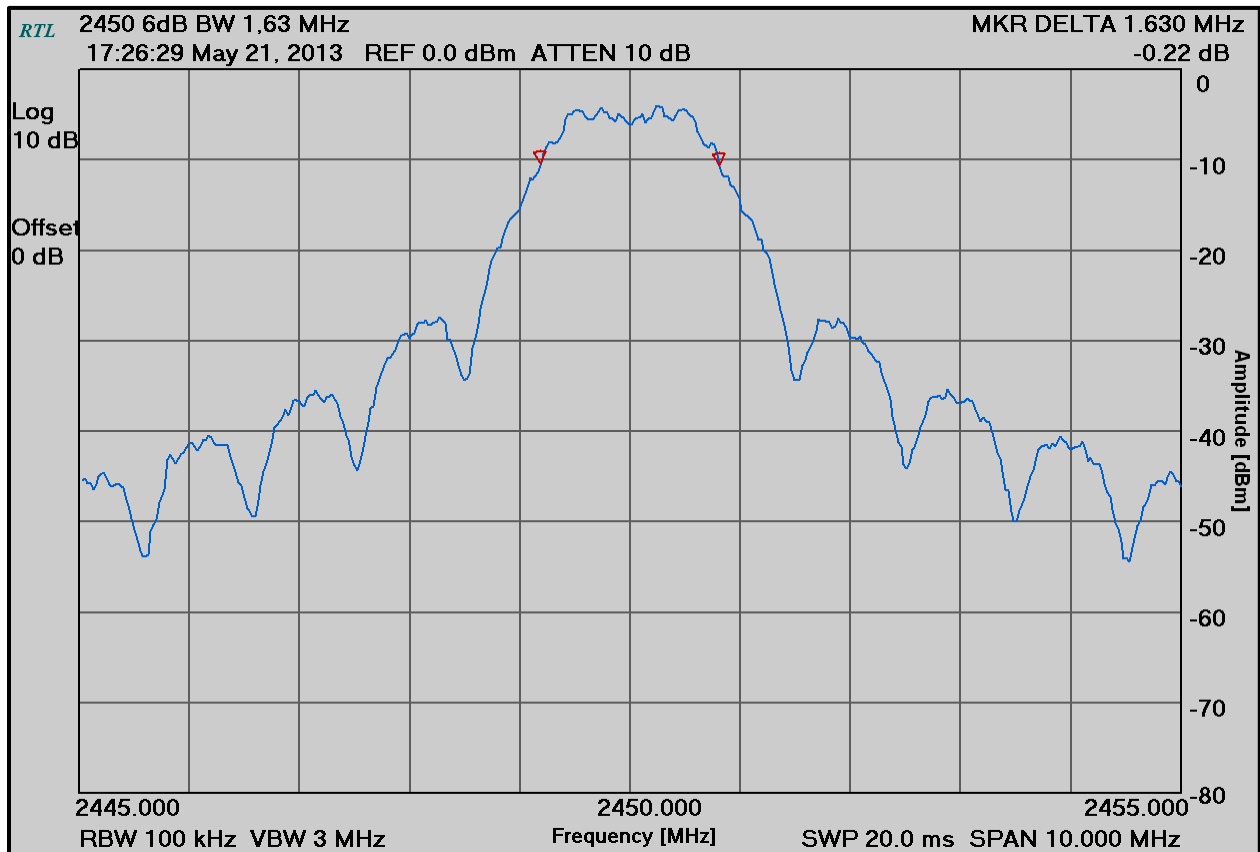

**Plot 7-3: 6 dB Bandwidth (2475 MHz)**

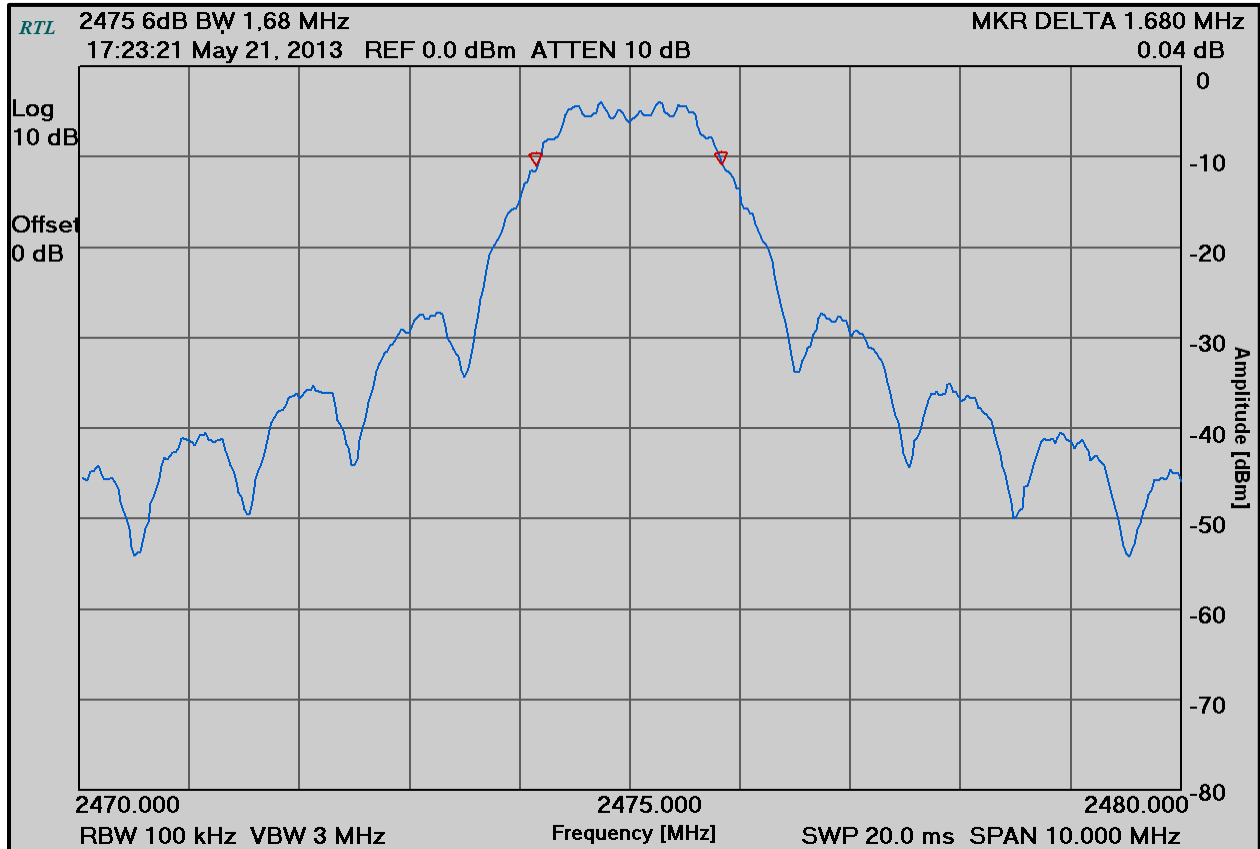

**Test Personnel:**

Daniel Baltzell  
Test Engineer

Signature

May 21, 2013  
Date of Tests

## 8 Power Spectral Density – FCC 15.247(e)

### 8.1 Power Spectral Density Test Procedure

The power spectral density per FCC 15.247(e) was measured using a 50 ohm spectrum analyzer with the span set at 1.5 MHz, the resolution bandwidth set at 3 kHz, the video bandwidth set at 30 kHz, and the sweep time set at 500 seconds. The spectral lines were resolved for the modulated carriers at 2.425 GHz, 2.450 GHz, and 2.475 GHz respectively. These levels are below the +8 dBm limit. See the power spectral density table and plots that follow.

**Table 8-1: Power Spectral Density Test Equipment**

RTL Asset #	Manufacturer	Model	Part Type	Serial Number	Calibration Due Date
901215	Hewlett Packard	8596EM	Spectrum Analyzer (9 kHz - 12.8 GHz)	3826A00144	3/15/14

### 8.2 Power Spectral Density Test Data

**Table 8-2: Power Spectral Density Test Data**

Frequency (MHz)	RF Power Level (dBm)	Maximum Limit +8dBm	Pass/Fail
2425	-18.2	8	Pass
2450	-18.1	8	Pass
2475	-18.4	8	Pass

**Plot 8-1: Power Spectral Density (2425 MHz)**

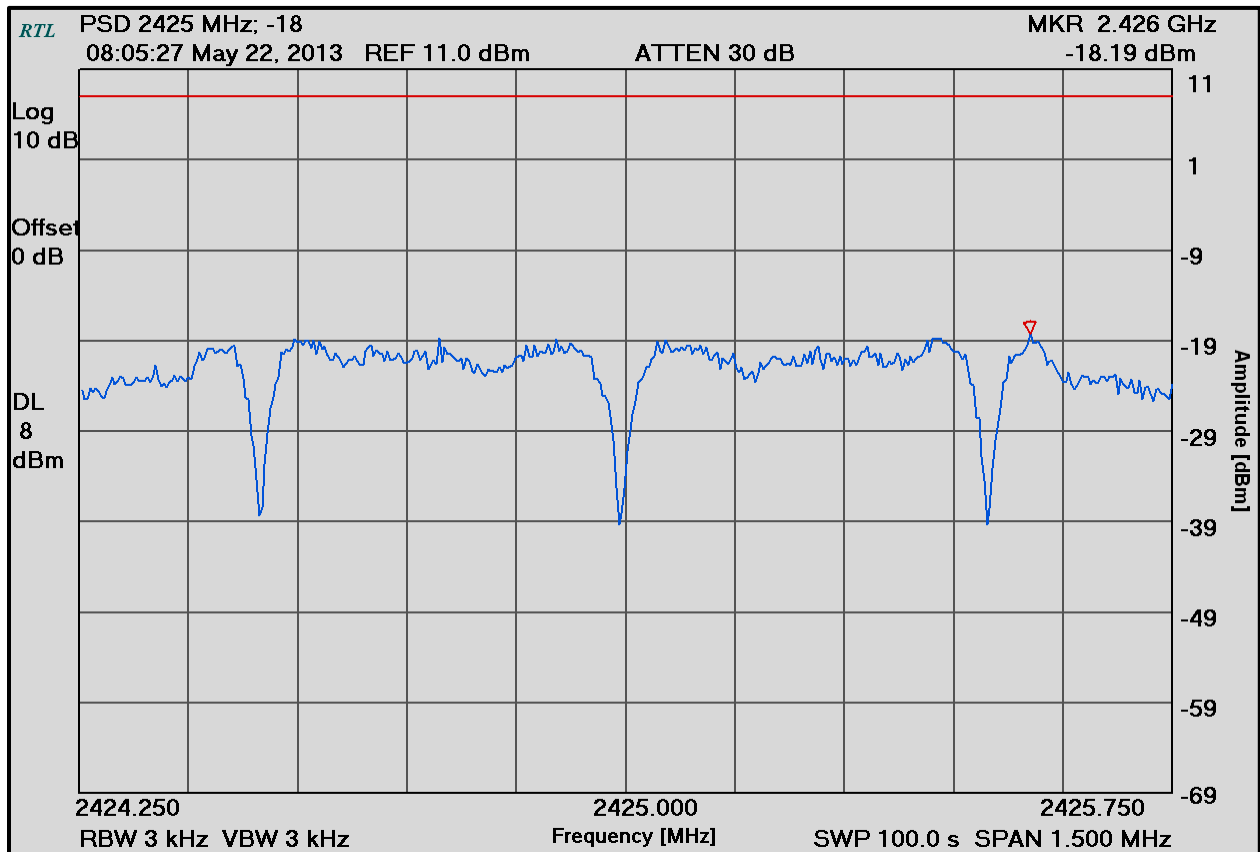

**Plot 8-2: Power Spectral Density (2450 MHz)**

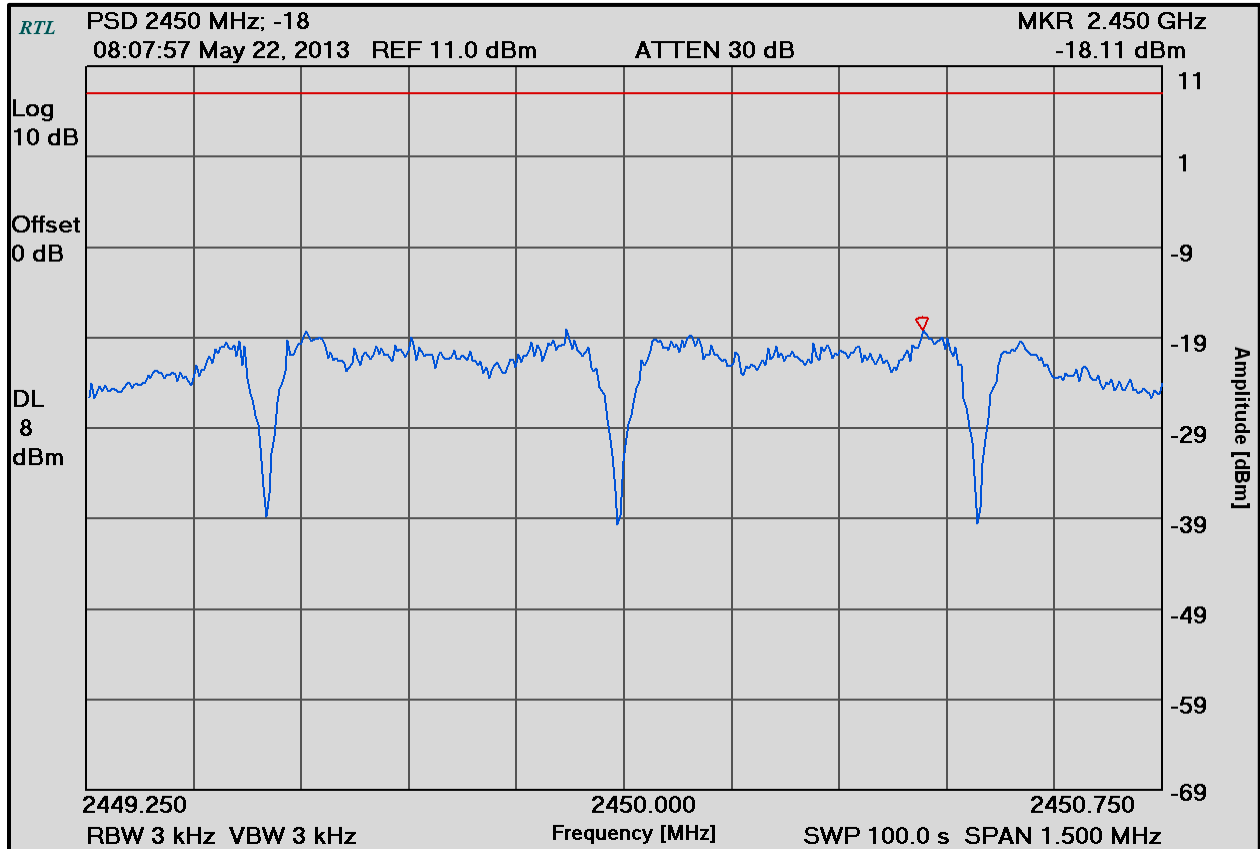

**Plot 8-3: Power Spectral Density (2475 MHz)**

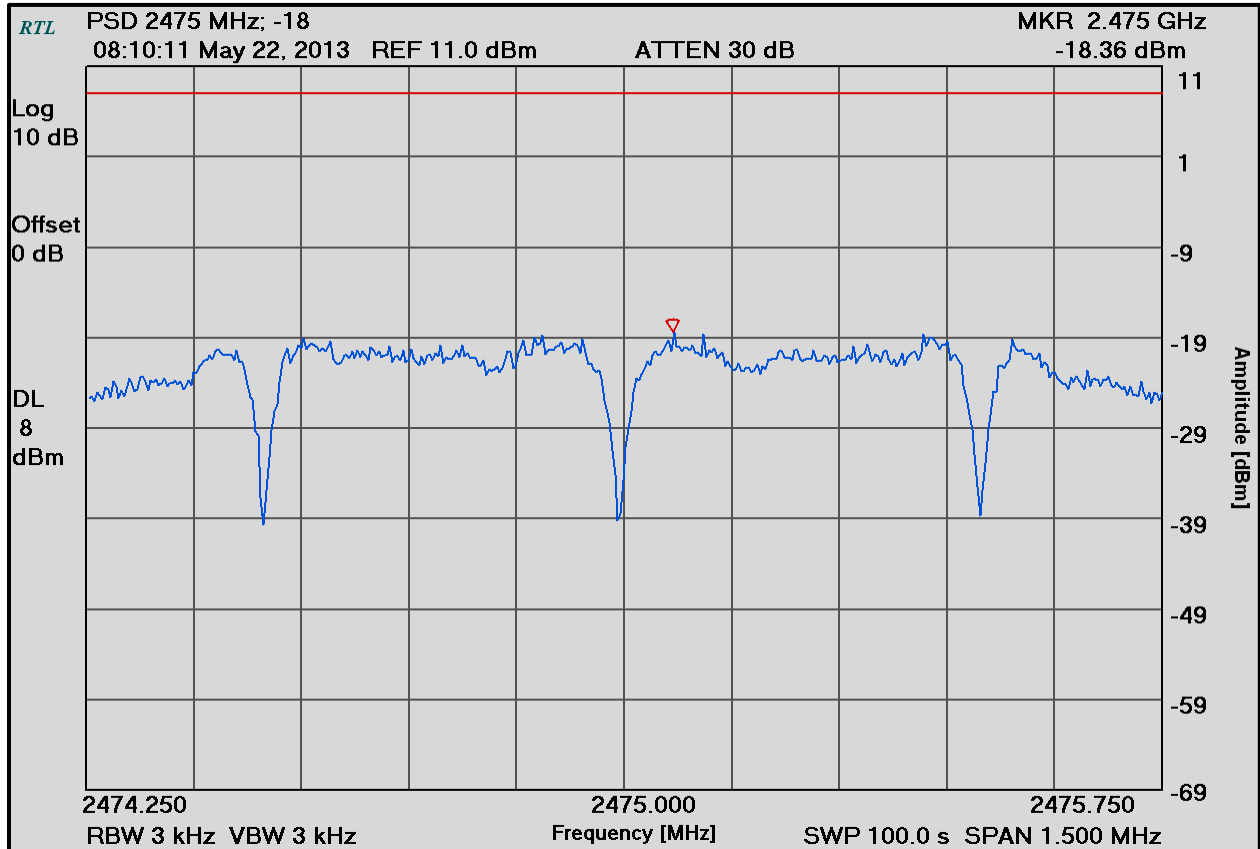

**Test Personnel:**

Daniel Baltzell  
Test Engineer

Signature

May 22 2013  
Date of Tests

## 9 Conducted Emissions Measurement Limits – FCC 15.207

### 9.1 Limits of Conducted Emissions Measurement

Frequency of Emission (MHz)	Conducted Limit (dBuV)	
	Quasi-peak	Average
0.15-0.5	66-56	56-46
0.5-5.0	56	46
5.0-30.0	60	50

### 9.2 Site and Test Description

The power line conducted emissions measurements were performed in a Series 81 type shielded enclosure manufactured by Rayproof. The EUT was assembled on a wooden table 80 centimeters high. Power was fed to the EUT through a 50 ohm/50 microhenry Line Impedance Stabilization Network (LISN). The EUT LISN was fed power through an A.C. filter box on the outside of the shielded enclosure. The filter box and EUT LISN housing are bonded to the ground plane of the shielded enclosure. A second LISN, the peripheral LISN, provides isolation for the EUT test peripherals. This peripheral LISN was also fed A.C. power. A metal power outlet box, which is bonded to the ground plane and electrically connected to the peripheral LISN, powers the EUT host peripherals.

The spectrum analyzer was connected to the A.C. line through an isolation transformer. The 50 ohm output of the EUT LISN was connected to the spectrum analyzer input through a Solar 100 kHz high-pass filter. The filter is used to prevent overload of the spectrum analyzer from noise below 100 kHz. Conducted emission levels were measured on each current-carrying line with the spectrum analyzer operating in the CISPR quasi-peak mode (or peak mode if applicable).

The analyzer's 6 dB bandwidth was set to 9 kHz. Video filter less than 10 times the resolution bandwidth is not used. Average measurements are performed in linear mode using a 10 kHz resolution bandwidth, a 1 Hz video bandwidth, and by increasing the sweep time in order to obtain a calibrated measurement. The emission spectrum was scanned from 150 kHz to 30 MHz. The highest emission amplitudes relative to the appropriate limits were measured and have been recorded.

**Table 9-1: Conducted Emissions Test Equipment**

RTL Asset #	Manufacturer	Model	Part Type	Serial Number	Calibration Due Date
901082	AFJ International	LS16	16A LISN	16010020081	3/26/14
900968	Hewlett Packard	8567A	Spectrum Analyzer (10 kHz - 1.5 GHz)	2602A00160	2/17/14
900969	Hewlett Packard	85650A	Quasi-Peak Adapter	2412A00414	2/17/14
900970	Hewlett Packard	85662A	Spectrum Analyzer Display	2542A11239	2/17/14



### 9.3 Conducted Emissions Test Data

Plot 9-1: Conducted Emissions Test Data – Neutral - RX Mode

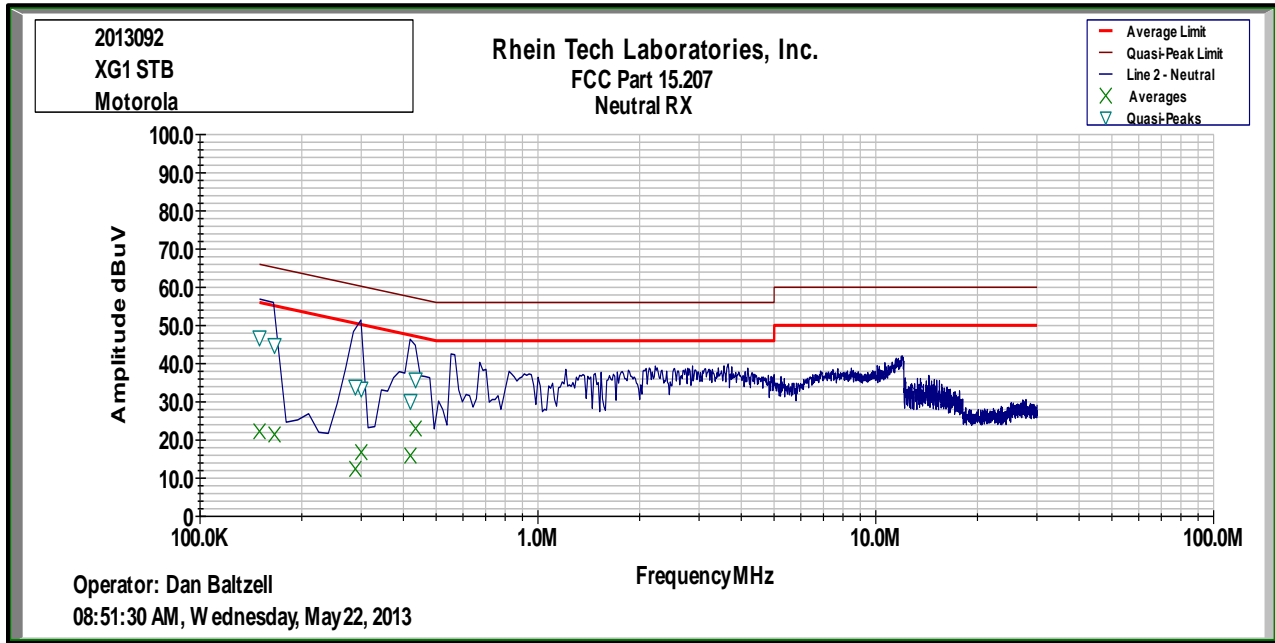

Plot 9-2: Conducted Emissions Test Data – Hot – RX Mode

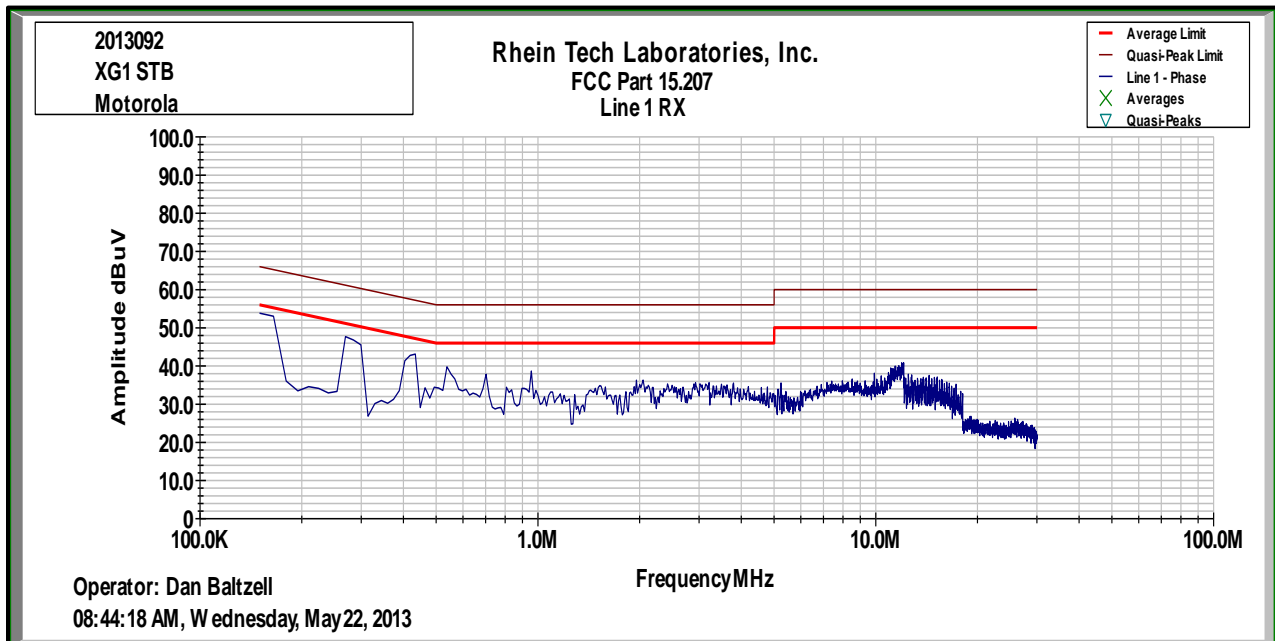

**Plot 9-3: Conducted Emissions Test Data – Neutral - TX Mode**

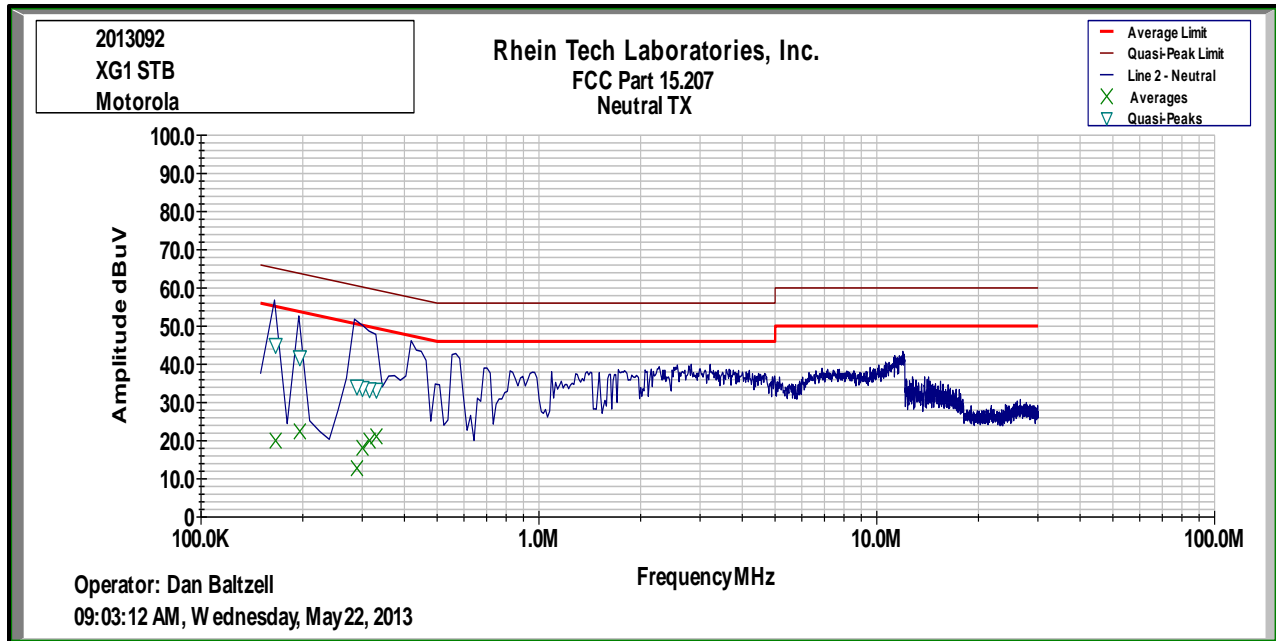

**Plot 9-4: Conducted Emissions Test Data – Hot – TX Mode**

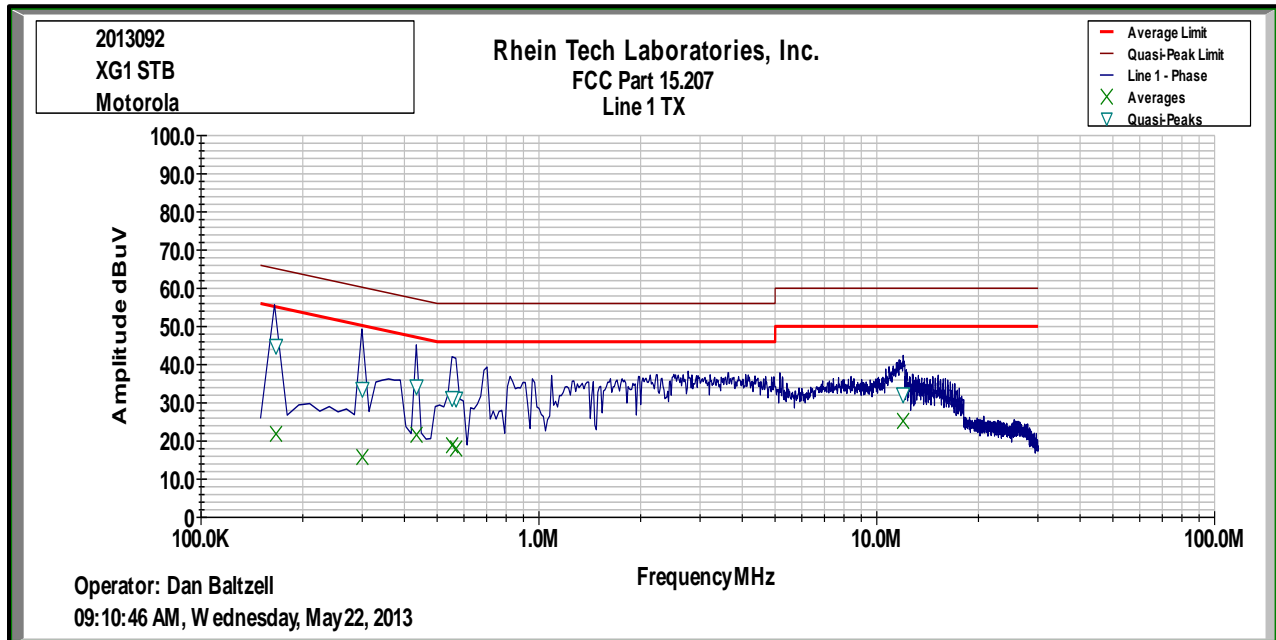

**Test Personnel:**

Daniel W. Baltzell  
 Test Engineer

Signature

May 22, 2013  
 Date of Tests

## **10 Radiated Emissions - FCC 15.209, 15.205**

As shown in 15.35(b), for frequencies above 1000 MHz, the field strength limits are based on average detector, however, the peak field strength of any emission shall not exceed the maximum permitted average limits, specified above by more than 20 dB under any circumstances of modulation.

### **10.1 Radiated Emissions Measurement Test Procedure**

Before final measurements of radiated emissions were made on the open-field three/ten meter range, the EUT was scanned indoors at one and three meter distances. This was done in order to determine its emissions spectrum signature. The physical arrangement of the test system and associated cabling was varied in order to determine the effect on the EUT's emissions in amplitude, direction and frequency. This process was repeated during final radiated emissions measurements on the open-field range, at each frequency, in order to ensure that maximum emission amplitudes were attained.

Final radiated emissions measurements were made on the three/ten-meter, open-field test site. The EUT was placed on a nonconductive turntable 0.8 meters above the ground plane. The spectrum was examined from 9 kHz to the 10<sup>th</sup> harmonic of the highest fundamental transmitter frequency (24.8 GHz).

At each frequency, the EUT was rotated 360°, and the antenna was raised and lowered from 1 to 4 meters in order to determine the emission's maximum level. Measurements were taken using both horizontal and vertical antenna polarizations. For frequencies between 30 and 1000 MHz, the spectrum analyzer's 6 dB bandwidth was set to 120 kHz, and the analyzer was operated in the CISPR quasi-peak detection mode. For emissions above 1000 MHz, emissions are measured using the average detector function with a minimum resolution bandwidth of 1 MHz. No video filter less than 10 times the resolution bandwidth was used. The highest emission amplitudes relative to the appropriate limit were measured and recorded in this report.

**Table 10-1: Radiated Emissions Test Equipment**

RTL Asset #	Manufacturer	Model	Part Type	Serial Number	Calibration Due Date
900151	Rohde & Schwarz	HFH2-Z2	Loop Antenna	827525/019	10/1/13
901583	Agilent Technologies	N9010A	EXA Signal Analyzer (10 Hz - 26.5 GHz)	MY51250846	4/16/14
900878	Rhein Tech Laboratories	AM3-1197-0005	3 meter antenna mast,	OATS1	Not Required
901242	Rhein Tech Laboratories	WRT-000-0003	Wood rotating table	N/A	Not Required
900772	EMCO	3161-02	Horn Antenna (2 - 4 GHz)	9804-1044	4/19/14
900321	EMCO	3161-03	Horn Antennas (4 - 8.2 GHz)	9508-1020	4/19/14
900323	EMCO	3160-7	Horn Antennas (8.2 - 12.4 GHz)	9605-1054	4/19/14
900356	EMCO	3160-08	Horn Antenna (12.4 - 18 GHz)	9607-1044	4/19/14
900325	EMCO	3160-9	Horn Antennas (18 - 26.5 GHz)	9605-1051	4/19/14
900791	Chase	CBL6111B	Bilog Antenna (30 MHz - 2000 MHz)	N/A	2/1/14
901592	Insulated Wire Inc.	KPS-1503-3600-KPR	SMK RF Cables 20'	NA	8/16/13
901593	Insulated Wire Inc.	KPS-1503-360-KPR	SMK RF Cables 36"	NA	8/16/13
900932	Hewlett Packard	8449B OPT H02	Preamplifier (1 - 26.5 GHz)	3008A00505	8/10/13
900905	Rhein Tech Laboratories	PR-1040	OATS 1 Preamplifier 40dB (30 MHz - 2 GHz)	1006	8/20/13

## 10.2 Radiated Emissions Test Results

### 10.2.1 Radiated Emissions Harmonics/Spurious Test Data

**Table 10-2: Radiated Emissions Harmonics/Spurious (2425 MHz) Average**

Emission Frequency (MHz)	Analyzer Average (dBuV) (Peak Value – 48.8 dB duty cycle correction)	Site Correction Factor (dB/m)	Average Emission Level (dBuV/m)	Average Limit (dBuV/m)	Average Margin (dB)
4850.0	16.0	-1.5	14.5	54.0	-39.5
7275.0	-5.6	0.9	-4.7	54.0	-58.7
12125.0	-29.8	10.2	-19.6	54.0	-73.6
19400.0	-29.3	21.2	-8.1	54.0	-62.1

**Table 10-3: Radiated Emissions Harmonics/Spurious (2425 MHz) Peak**

Emission Frequency (MHz)	Peak Analyzer Reading (dBuV) (1 MHz RBW/VBW)	Site Correction Factor (dB/m)	Peak Emission Level (dBuV/m)	Peak Limit (dBuV/m)	Peak Margin (dB)
4850.0	64.8	-1.5	63.3	74.0	-10.7
7275.0	43.2	0.9	44.1	74.0	-29.9
12125.0	19.0	10.2	29.2	74.0	-44.8
19400.0	19.5	21.2	40.7	74.0	-33.3

**Table 10-4: Radiated Emissions Harmonics/Spurious (2450 MHz) Average**

Emission Frequency (MHz)	Analyzer Average (dBuV) (Peak Value – 48.8 dB duty cycle correction)	Site Correction Factor (dB/m)	Average Emission Level (dBuV/m)	Average Limit (dBuV/m)	Average Margin (dB)
4900.0	9.7	-1.4	8.3	54.0	-45.7
7350.0	-6.1	0.7	-5.4	54.0	-59.4
12250.0	-5.4	10.2	4.8	54.0	-49.2
19600.0	-29.3	20.6	-8.7	54.0	-62.7
22050.0	-29.1	23.4	-5.7	54.0	-59.7

**Table 10-5: Radiated Emissions Harmonics/Spurious (2450 MHz) Peak**

Emission Frequency (MHz)	Peak Analyzer Reading (dBuV) (1 MHz RBW/ VBW)	Site Correction Factor (dB/m)	Peak Emission Level (dBuV/m)	Peak Limit (dBuV/m)	Peak Margin (dB)
4900.0	58.5	-1.4	57.1	74.0	-16.9
7350.0	42.7	0.7	43.4	74.0	-30.6
12250.0	43.4	10.2	53.6	74.0	-20.4
19600.0	19.5	20.6	40.1	74.0	-33.9
22050.0	19.7	23.4	43.1	74.0	-30.9

**Table 10-6: Radiated Emissions Harmonics/Spurious (2475 MHz) Average**

Emission Frequency (MHz)	Analyzer Average (dBuV) (Peak Value – 48.8 dB duty cycle correction)	Site Correction Factor (dB/m)	Average Emission Level (dBuV/m)	Average Limit (dBuV/m)	Average Margin (dB)
4950.0	9.7	-1.2	8.5	54.0	-45.5
7425.0	-2.3	0.8	-1.5	54.0	-55.5
12375.0	-6.3	10.1	3.8	54.0	-50.2
19800.0	-28.8	22.3	-6.5	54.0	-60.5
22275.0	-30.0	27.4	-2.6	54.0	-56.6

**Table 10-7: Radiated Emissions Harmonics/Spurious (2475 MHz) Peak**

Emission Frequency (MHz)	Peak Analyzer Reading (dBuV) (1 MHz RBW/ VBW)	Site Correction Factor (dB/m)	Peak Emission Level (dBuV/m)	Peak Limit (dBuV/m)	Peak Margin (dB)
4950.0	58.5	-1.2	57.3	74.0	-16.7
7425.0	46.5	0.8	47.3	74.0	-26.7
12375.0	42.5	10.1	52.6	74.0	-21.4
19800.0	20.0	22.3	42.3	74.0	-31.7
22275.0	18.8	27.4	46.2	74.0	-27.8

**Test Personnel:**

Daniel Baltzell  
 Test Engineer



Signature

May 22, 2013  
 Date of Test

Rhein Tech Laboratories, Inc.  
360 Herndon Parkway  
Suite 1400  
Herndon, VA 20170  
<http://www.rheintech.com>

Client: Motorola, Inc.  
Model: XG1  
Standard: FCC 15.247  
FCC ID: ACQ-XG1  
Report #: 2013092

## **11 Conclusion**

The data in this measurement report shows that the EUT as tested, Motorola, Inc. Set Top Box Model XG1, FCC ID: ACQ-XG1, complies with all the applicable requirements of Parts 2 and 15 of the FCC Rules and Regulations.