



A D T

FCC TEST REPORT (15.247)

REPORT NO.: RF120917C21 R1
MODEL NO.: VIP2500
FCC ID: ACQ-VIP2500
RECEIVED: Sep. 17, 2012
TESTED: Sep. 25 ~ Nov. 27, 2012;
Feb. 22, 2013
ISSUED: Feb. 23, 2013

APPLICANT: Motorola Mobility, LLC.

ADDRESS: 101 Tournament Drive Horsham, PA 19044 United States

ISSUED BY: Bureau Veritas Consumer Products Services (H.K.) Ltd., Taoyuan Branch

LAB ADDRESS: No. 47, 14th Ling, Chia Pau Vil., Lin Kou Dist., New Taipei City, Taiwan, R.O.C.

TEST LOCATION: No. 19, Hwa Ya 2nd Rd, Wen Hwa Tsuen, Kwei Shan Hsiang, Taoyuan Hsien 333, Taiwan, R.O.C.

This report should not be used by the client to claim product certification, approval, or endorsement by TAF or any government agencies.



This report is for your exclusive use. Any copying or replication of this report to or for any other person or entity, or use of our name or trademark, is permitted only with our prior written permission. This report sets forth our findings solely with respect to the test samples identified herein. The results set forth in this report are not indicative or representative of the quality or characteristics of the lot from which a test sample was taken or any similar or identical product unless specifically and expressly noted. Our report includes all of the tests requested by you and the results thereof based upon the information that you provided to us. You have 60 days from date of issuance of this report to notify us of any material error or omission caused by our negligence, provided, however, that such notice shall be in writing and shall specifically address the issue you wish to raise. A failure to raise such issue within the prescribed time shall constitute your unqualified acceptance of the completeness of this report, the tests conducted and the correctness of the report contents. Unless specific mention, the uncertainty of measurement has been explicitly taken into account to declare the compliance or non-compliance to the specification.



TABLE OF CONTENTS

RELEASE CONTROL RECORD.....	4
1. CERTIFICATION.....	5
2. SUMMARY OF TEST RESULTS	6
2.1 MEASUREMENT UNCERTAINTY.....	6
3. GENERAL INFORMATION.....	7
3.1 GENERAL DESCRIPTION OF EUT	7
3.2 DESCRIPTION OF TEST MODES	8
3.2.1 TEST MODE APPLICABILITY AND TESTED CHANNEL DETAIL	9
3.3 DESCRIPTION OF SUPPORT UNITS	11
3.3.1 CONFIGURATION OF SYSTEM UNDER TEST	11
3.4 GENERAL DESCRIPTION OF APPLIED STANDARDS	12
4. TEST TYPES AND RESULTS	13
4.1 RADIATED EMISSION MEASUREMENT	13
4.1.1 LIMITS OF RADIATED EMISSION MEASUREMENT	13
4.1.2 TEST INSTRUMENTS.....	14
4.1.3 TEST PROCEDURES	16
4.1.4 DEVIATION FROM TEST STANDARD.....	16
4.1.5 TEST SETUP	17
4.1.6 EUT OPERATING CONDITIONS	17
4.1.7 TEST RESULTS	18
4.2 CONDUCTED EMISSION MEASUREMENT	30
4.2.1 LIMITS OF CONDUCTED EMISSION MEASUREMENT	30
4.2.2 TEST INSTRUMENTS.....	30
4.2.3 TEST PROCEDURES	32
4.2.4 DEVIATION FROM TEST STANDARD.....	32
4.2.5 TEST SETUP	32
4.2.6 EUT OPERATING CONDITIONS	32
4.2.7 TEST RESULTS	33
4.3 6dB BANDWIDTH MEASUREMENT.....	41
4.3.1 LIMITS OF 6dB BANDWIDTH MEASUREMENT	41
4.3.2 TEST SETUP.....	41
4.3.3 TEST INSTRUMENTS.....	41
4.3.4 TEST PROCEDURE.....	41
4.3.5 DEVIATION FROM TEST STANDARD.....	41
4.3.6 EUT OPERATING CONDITIONS	41
4.3.7 TEST RESULTS	42
4.4 CONDUCTED OUTPUT POWER.....	43
4.4.1 LIMITS OF CONDUCTED OUTPUT POWER MEASUREMENT	43
4.4.2 TEST SETUP.....	43
4.4.3 TEST INSTRUMENTS.....	43
4.4.4 TEST PROCEDURES	43
4.4.5 DEVIATION FROM TEST STANDARD.....	44
4.4.6 EUT OPERATING CONDITIONS	44
4.4.7 TEST RESULTS	45
4.5 POWER SPECTRAL DENSITY MEASUREMENT	47
4.5.1 LIMITS OF POWER SPECTRAL DENSITY MEASUREMENT	47
4.5.2 TEST SETUP	47
4.5.3 TEST INSTRUMENTS.....	47



A D T

4.5.4	TEST PROCEDURE.....	47
4.5.5	DEVIATION FROM TEST STANDARD.....	47
4.5.6	EUT OPERATING CONDITION.....	47
4.5.7	TEST RESULTS	48
4.6	CONDUCTED OUT OF BAND EMISSION MEASUREMENT.....	49
4.6.1	LIMITS OF CONDUCTED OUT OF BAND EMISSION MEASUREMENT	49
4.6.2	TEST SETUP.....	49
4.6.3	TEST INSTRUMENTS.....	49
4.6.4	TEST PROCEDURE.....	49
4.6.5	DEVIATION FROM TEST STANDARD.....	50
4.6.6	EUT OPERATING CONDITION.....	50
4.6.7	TEST RESULTS	50
5.	PHOTOGRAPHS OF THE TEST CONFIGURATION.....	54
6.	INFORMATION ON THE TESTING LABORATORIES	55
7.	APPENDIX A - MODIFICATIONS RECORDERS FOR ENGINEERING CHANGES TO THE EUT BY THE LAB.....	56



A D T

RELEASE CONTROL RECORD

ISSUE NO.	REASON FOR CHANGE	DATE ISSUED
RF120917C21	Original release	Dec. 03, 2012
RF120917C21 R1	Update 6dB bandwidth & power density for new KDB	Feb. 23, 2013



A D T

1. CERTIFICATION

PRODUCT: VIP2500 set top box

MODEL NO.: VIP2500

BRAND: Motorola

APPLICANT: Motorola Mobility, LLC.

TESTED: Sep. 25 ~ Nov. 27, 2012; Feb. 22, 2013

TEST SAMPLE: ENGINEERING SAMPLE

STANDARDS: **FCC Part 15, Subpart C (Section 15.247)**

ANSI C63.10-2009

The above equipment (model: VIP2500) has been tested by **Bureau Veritas Consumer Products Services (H.K.) Ltd., Taoyuan Branch**, and found compliance with the requirement of the above standards. The test record, data evaluation & Equipment Under Test (EUT) configurations represented herein are true and accurate accounts of the measurements of the sample's EMC characteristics under the conditions specified in this report.

PREPARED BY : Celine Chou , **DATE** : Feb. 23, 2013
Celine Chou / Specialist

APPROVED BY : Ken Liu , **DATE** : Feb. 23, 2013
Ken Liu / Manager



2. SUMMARY OF TEST RESULTS

The EUT has been tested according to the following specifications:

APPLIED STANDARD: FCC PART 15, SUBPART C (SECTION 15.247)			
STANDARD SECTION	TEST TYPE	RESULT	REMARK
15.207	AC Power Conducted Emission	PASS	Meet the requirement of limit. Minimum passing margin is -1.42dB at 0.17344MHz.
15.247(d) 15.209	Radiated Emissions	PASS	Meet the requirement of limit. Minimum passing margin is -1.1dB at 11570.00MHz.
15.247(d)	Band Edge Measurement	PASS	Meet the requirement of limit.
15.247(a)(2)	6dB bandwidth	PASS	Meet the requirement of limit.
15.247(b)	Conducted power	PASS	Meet the requirement of limit.
15.247(e)	Power Spectral Density	PASS	Meet the requirement of limit.
15.203	Antenna Requirement	PASS	Antenna connector is I-PEX not a standard connector.

2.1 MEASUREMENT UNCERTAINTY

Where relevant, the following measurement uncertainty levels have been estimated for tests performed on the EUT as specified in CISPR 16-4-2:

MEASUREMENT	FREQUENCY	UNCERTAINTY
Conducted emissions	9kHz~30MHz	2.44 dB
Radiated emissions	30MHz ~ 200MHz	3.19 dB
	200MHz ~1000MHz	3.21 dB
	1GHz ~ 18GHz	2.26 dB
	18GHz ~ 40GHz	1.94 dB

This uncertainty represents an expanded uncertainty expressed at approximately the 95% confidence level using a coverage factor of $k = 2$.



3. GENERAL INFORMATION

3.1 GENERAL DESCRIPTION OF EUT

EUT	VIP2500 set top box
MODEL NO.	VIP2500
POWER SUPPLY	12Vdc (Adapter)
MODULATION TYPE	64QAM, 16QAM, QPSK, BPSK
MODULATION TECHNOLOGY	OFDM
TRANSFER RATE	802.11a: 54.0/ 48.0/ 36.0/ 24.0/ 18.0/ 12.0/ 9.0/ 6.0Mbps 802.11n: up to 300.0Mbps
OPERATING FREQUENCY	5745 ~ 5825MHz
NUMBER OF CHANNEL	5 for 802.11a, 802.11n (20MHz) 2 for 802.11n (40MHz)
OUTPUT POWER	517.71mW
ANTENNA TYPE	Dipole antenna with 0.4dBi gain
ANTENNA CONNECTOR	I-PEX
DATA CABLE	NA
I/O PORTS	Refer to user's manual
ACCESSORY DEVICES	Adapter

NOTE:

1. The EUT incorporates a MIMO function. Physically, the EUT provides two completed transmitters and four receivers.

MODULATION MODE	TX FUNCTION
802.11a	2TX
802.11n (20MHz)	2TX
802.11n (40MHz)	2TX

2. The EUT consumes power from the following adapters:

ADAPTER 1	
BRAND	LEADER ELECTRONICS INC.
MODEL	ML18-V120150-A1
INPUT POWER	120Vac, 60Hz, 0.5A
OUTPUT POWER	12Vdc, 1.5A
POWER LINE	1.5m non-shielded cable w/o core

ADAPTER 2	
BRAND	Asian Power Devices Inc.
MODEL	WB-18F12FU
INPUT POWER	110-120Vac, 50-60Hz, 0.6A Max.
OUTPUT POWER	12Vdc, 1.5A
POWER LINE	1.5m non-shielded cable w/o core



A D T

ADAPTER 3	
BRAND	LITEON
MODEL	PB-1180-1M01
INPUT POWER	100-132Vac~60Hz, 0.6A
OUTPUT POWER	12Vdc, 1.5A
POWER LINE	1.5m non-shielded cable w/o core

ADAPTER 4	
BRAND	DELTA Electronics, INC.
MODEL	ADP-18AR AA
INPUT POWER	110-120Vac,57-63Hz, 0.8A
OUTPUT POWER	12Vdc, 1.5A
POWER LINE	1.5m non-shielded cable w/o core

3. The above EUT information is declared by manufacturer and for more detailed features description, please refer to the manufacturer's specifications or user's manual.

3.2 DESCRIPTION OF TEST MODES

5 channels are provided for 802.11a, 802.11n (20MHz):

CHANNEL	FREQUENCY	CHANNEL	FREQUENCY
149	5745MHz	161	5805MHz
153	5765MHz	165	5825MHz
157	5785MHz		

2 channels are provided for 802.11n (40MHz):

CHANNEL	FREQUENCY	CHANNEL	FREQUENCY
151	5755MHz	159	5795MHz



A D T

3.2.1 TEST MODE APPLICABILITY AND TESTED CHANNEL DETAIL

EUT CONFIGURE MODE	APPLICABLE TO				DESCRIPTION
	RE \geq 1G	RE<1G	PLC	APCM	
A	-	√	√	-	Power form Adapter 1
B	-	√	√	-	Power form Adapter 2
C	√	√	√	√	Power form Adapter 3
D	-	√	√	-	Power form Adapter 4

Where **RE \geq 1G**: Radiated Emission above 1GHz **RE<1G**: Radiated Emission below 1GHz
PLC: Power Line Conducted Emission **APCM**: Antenna Port Conducted Measurement

NOTE: 1. The EUT had been pre-tested on the positioned of each 3 axis. The worst case was found when positioned on **X-plane**.

2. "-" means no effect.

RADIATED EMISSION TEST (ABOVE 1GHz):

- Pre-Scan has been conducted to determine the worst-case mode from all possible combinations between available modulations, data rates and antenna ports (if EUT with antenna diversity architecture).
- Following channel(s) was (were) selected for the final test as listed below.

EUT CONFIGURE MODE	MODE	AVAILABLE CHANNEL	TESTED CHANNEL	MODULATION TECHNOLOGY	MODULATION TYPE	DATA RATE (Mbps)
C	802.11a	149 to 165	149, 157, 165	OFDM	BPSK	6.0
C	802.11n (20MHz)	149 to 165	149, 157, 165	OFDM	BPSK	7.2
C	802.11n (40MHz)	151 to 159	151, 159	OFDM	BPSK	15.0

RADIATED EMISSION TEST (BELOW 1GHz):

- Pre-Scan has been conducted to determine the worst-case mode from all possible combinations between available modulations, data rates and antenna ports (if EUT with antenna diversity architecture).
- Following channel(s) was (were) selected for the final test as listed below.

EUT CONFIGURE MODE	MODE	AVAILABLE CHANNEL	TESTED CHANNEL	MODULATION TECHNOLOGY	MODULATION TYPE	DATA RATE (Mbps)
A, B, C & D	802.11n (20MHz)	149 to 165	149	OFDM	BPSK	7.2

POWER LINE CONDUCTED EMISSION TEST:

- Pre-Scan has been conducted to determine the worst-case mode from all possible combinations between available modulations, data rates and antenna ports (if EUT with antenna diversity architecture).
- Following channel(s) was (were) selected for the final test as listed below.

EUT CONFIGURE MODE	MODE	AVAILABLE CHANNEL	TESTED CHANNEL	MODULATION TECHNOLOGY	MODULATION TYPE	DATA RATE (Mbps)
A, B, C & D	802.11n (40MHz)	151 to 159	159	OFDM	BPSK	15.0



A D T

BANDEDGE MEASUREMENT:

- Pre-Scan has been conducted to determine the worst-case mode from all possible combinations between available modulations, data rates and antenna ports (if EUT with antenna diversity architecture).
- Following channel(s) was (were) selected for the final test as listed below.

EUT CONFIGURE MODE	MODE	AVAILABLE CHANNEL	TESTED CHANNEL	MODULATION TECHNOLOGY	MODULATION TYPE	DATA RATE (Mbps)
C	149 to 165	149, 165	149, 157, 165	OFDM	BPSK	6.0
C	149 to 165	149, 165	149, 157, 165	OFDM	BPSK	7.2
C	151 to 159	151, 159	151, 159	OFDM	BPSK	15.0

ANTENNA PORT CONDUCTED MEASUREMENT:

- This item includes all test value of each mode, but only includes spectrum plot of worst value of each mode.
- Pre-Scan has been conducted to determine the worst-case mode from all possible combinations between available modulations, data rates and antenna ports (if EUT with antenna diversity architecture).
- Following channel(s) was (were) selected for the final test as listed below.

EUT CONFIGURE MODE	MODE	AVAILABLE CHANNEL	TESTED CHANNEL	MODULATION TECHNOLOGY	MODULATION TYPE	DATA RATE (Mbps)
C	802.11a	149 to 165	149, 157, 165	OFDM	BPSK	6.0
C	802.11n (20MHz)	149 to 165	149, 157, 165	OFDM	BPSK	7.2
C	802.11n (40MHz)	151 to 159	151, 159	OFDM	BPSK	15.0

TEST CONDITION:

APPLICABLE TO	ENVIRONMENTAL CONDITIONS	INPUT POWER	TESTED BY
RE \geq 1G	23deg. C, 66%RH 24deg. C, 72%RH	120Vac, 60Hz	Alan Wu Cedric Wu
RE $<$ 1G	26deg. C, 77%RH 24deg. C, 72%RH 25deg. C, 65%RH	120Vac, 60Hz	Cedric Wu Alan Wu
PLC	26deg. C, 65%RH 25deg. C, 65%RH	120Vac, 60Hz	Cedric Wu
APCM	25deg. C, 65%RH	120Vac, 60Hz	Mark Liao

3.3 DESCRIPTION OF SUPPORT UNITS

The EUT has been tested as an independent unit together with other necessary accessories or support units. The following support units or accessories were used to form a representative test configuration during the tests.

NO.	PRODUCT	BRAND	MODEL NO.	SERIAL NO.	FCC ID
1	MONITOR	Panasonic	TH-L32E30W	14300669	FCC DoC Approved
2	NOTEBOOK	DELL	E5420	33MKMQ1	FCC DoC Approved
3	USB FLASH	Transcend	Jet Flash	NA	NA

NO.	SIGNAL CABLE DESCRIPTION OF THE ABOVE SUPPORT UNITS
1	1.8m HDMI cable
2	30m non-shielded RJ45 cable
3	NA

- NOTE:** 1. All power cords of the above support units are non shielded (1.8m).
 2. Item 2 as a communication partner to transfer data.
 3. Item 3 & HDMI cable were supplied from client

3.3.1 CONFIGURATION OF SYSTEM UNDER TEST

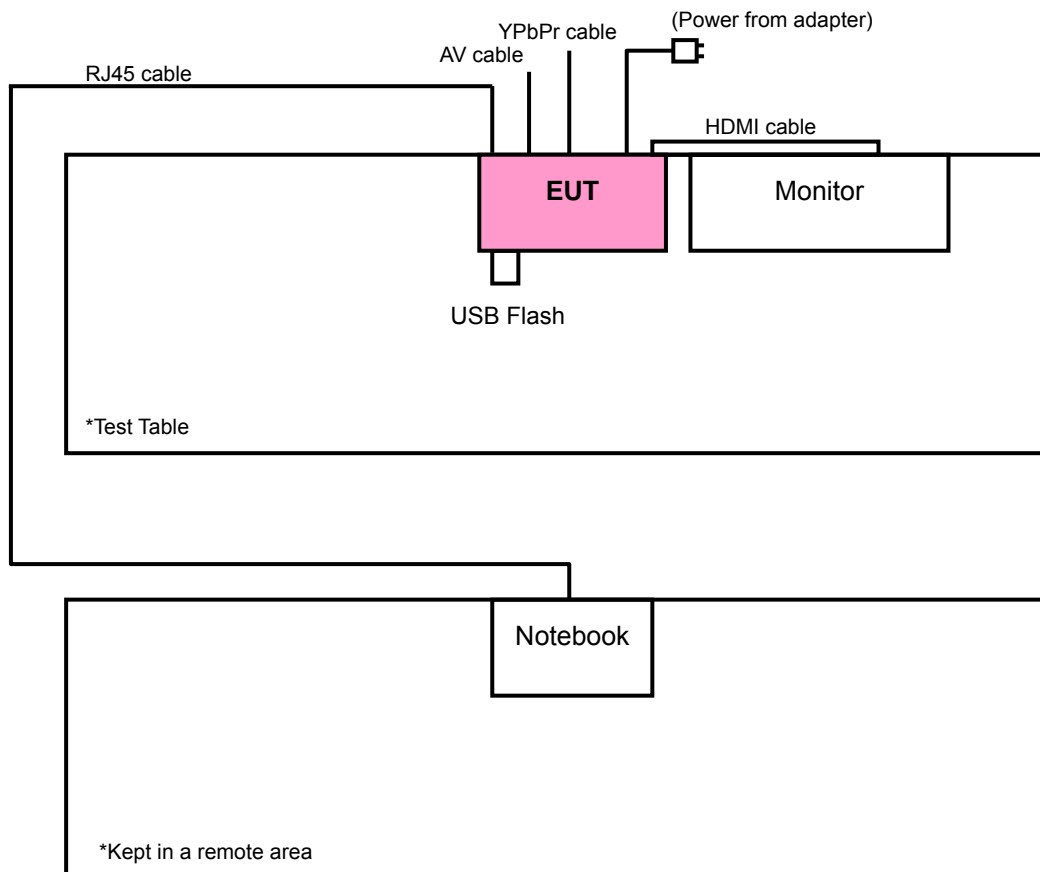



A D T

3.4 GENERAL DESCRIPTION OF APPLIED STANDARDS

The EUT is a RF Product. According to the specifications of the manufacturer, it must comply with the requirements of the following standards:

FCC Part 15, Subpart C (15.247)

558074 D01 DTS Meas Guidance v02

662911 D01 Multiple Transmitter Output v01 r02

ANSI C63.10-2009

All test items have been performed and recorded as per the above standards.

NOTE: The EUT is also considered as a kind of computer peripheral, because the connection to computer is necessary for typical use. It has been verified to comply with the requirements of FCC Part 15, Subpart B, Class B (DoC). The test report has been issued separately.



4. TEST TYPES AND RESULTS

4.1 RADIATED EMISSION MEASUREMENT

4.1.1 LIMITS OF RADIATED EMISSION MEASUREMENT

Radiated emissions which fall in the restricted bands must comply with the radiated emission limits specified as below table. Other emissions shall be at least 20dB below the highest level of the desired power:

FREQUENCIES (MHz)	FIELD STRENGTH (microvolts/meter)	MEASUREMENT DISTANCE (meters)
0.009 ~ 0.490	2400/F(kHz)	300
0.490 ~ 1.705	24000/F(kHz)	30
1.705 ~ 30.0	30	30
30 ~ 88	100	3
88 ~ 216	150	3
216 ~ 960	200	3
Above 960	500	3

NOTE:

1. The lower limit shall apply at the transition frequencies.
2. Emission level (dBuV/m) = 20 log Emission level (uV/m).
3. For frequencies above 1000MHz, the field strength limits are based on average detector, however, the peak field strength of any emission shall not exceed the maximum permitted average limits, specified above by more than 20dB under any condition of modulation.



A D T

4.1.2 TEST INSTRUMENTS

TEST MODE A, B, C (Tested Date: Sep. 25 ~ Oct. 04, 2012)

DESCRIPTION & MANUFACTURER	MODEL NO.	SERIAL NO.	DATE OF CALIBRATION	DUE DATE OF CALIBRATION
Test Receiver ROHDE & SCHWARZ	ESI7	838496/016	Jan. 03, 2012	Jan. 02, 2013
Spectrum Analyzer ROHDE & SCHWARZ	FSP 40	100039	Feb. 03, 2012	Feb. 02, 2013
BILOG Antenna SCHWARZBECK	VULB9168	9168-155	Apr. 06, 2012	Apr. 05, 2013
HORN Antenna SCHWARZBECK	BBHA 9120D	9120D-408	Jan. 05, 2012	Jan. 04, 2013
HORN Antenna SCHWARZBECK	BBHA 9170	148	Jul. 11, 2012	Jul. 10, 2013
Loop Antenna	HFH2-Z2	100070	Jan. 31, 2012	Jan. 30, 2014
Preamplifier Agilent	8449B	3008A01961	Oct. 25, 2011	Oct. 24, 2012
Preamplifier Agilent	8447D	2944A10738	Oct. 26, 2011	Oct. 25, 2012
RF signal cable HUBER+SUHNNER	SUCOFLEX 104	309220/4	Nov. 03, 2011	Nov. 02, 2012
RF signal cable HUBER+SUHNNER	SUCOFLEX 104	250724/4	Nov. 03, 2011	Nov. 02, 2012
RF signal cable HUBER+SUHNNER	SUCOFLEX 104	295012/4	Nov. 03, 2011	Nov. 02, 2012
Software ADT	ADT_Radiated_ V7.6.15.9.2	NA	NA	NA
Antenna Tower inn-co GmbH	MA 4000	010303	NA	NA
Antenna Tower Controller inn-co GmbH	CO2000	019303	NA	NA
Turn Table ADT	TT100.	TT93021704	NA	NA
Turn Table Controller ADT	SC100.	SC93021704	NA	NA
26GHz ~ 40GHz Amplifier	EM26400	815221	Oct. 25, 2011	Oct. 24, 2012
High Speed Peak Power Meter	ML2495A	0842014	Apr. 28, 2012	Apr. 27, 2013
Power Sensor	MA2411B	0738404	Apr. 28, 2012	Apr. 27, 2013

- NOTE:**
1. The calibration interval of the above test instruments is 12 months and the calibrations are traceable to NML/ROC and NIST/USA.
 2. The calibration interval of the loop antenna is 24 months and the calibrations are traceable to NML/ROC and NIST/USA.
 3. The test was performed in HwaYa Chamber 4.
 4. The horn antenna and HP preamplifier (model: 8449B) are used only for the measurement of emission frequency above 1GHz if tested.
 5. The FCC Site Registration No. is 460141.
 6. The IC Site Registration No. is IC7450F-4.



A D T

TEST MODE D (Tested Date: Nov. 26 ~ Nov. 27, 2012)

DESCRIPTION & MANUFACTURER	MODEL NO.	SERIAL NO.	DATE OF CALIBRATION	DUE DATE OF CALIBRATION
Test Receiver ROHDE & SCHWARZ	ESI7	838496/016	Jan. 03, 2012	Jan. 02, 2013
Spectrum Analyzer ROHDE & SCHWARZ	FSP 40	100039	Feb. 03, 2012	Feb. 02, 2013
BILOG Antenna SCHWARZBECK	VULB9168	9168-155	Apr. 06, 2012	Apr. 05, 2013
HORN Antenna SCHWARZBECK	BBHA 9120D	9120D-408	Jan. 05, 2012	Jan. 04, 2013
HORN Antenna SCHWARZBECK	BBHA 9170	148	Jul. 11, 2012	Jul. 10, 2013
Loop Antenna	HFH2-Z2	100070	Jan. 31, 2012	Jan. 30, 2014
Preamplifier Agilent	8449B	3008A01961	Oct. 25, 2012	Oct. 24, 2013
Preamplifier Agilent	8447D	2944A10738	Oct. 26, 2012	Oct. 25, 2013
RF signal cable HUBER+SUHNNER	SUCOFLEX 104	309220/4	Nov. 03, 2012	Nov. 02, 2013
RF signal cable HUBER+SUHNNER	SUCOFLEX 104	250724/4	Nov. 03, 2012	Nov. 02, 2013
RF signal cable HUBER+SUHNNER	SUCOFLEX 104	295012/4	Nov. 03, 2012	Nov. 02, 2013
Software ADT	ADT_Radiated_ V7.6.15.9.2	NA	NA	NA
Antenna Tower inn-co GmbH	MA 4000	010303	NA	NA
Antenna Tower Controller inn-co GmbH	CO2000	019303	NA	NA
Turn Table ADT	TT100.	TT93021704	NA	NA
Turn Table Controller ADT	SC100.	SC93021704	NA	NA
26GHz ~ 40GHz Amplifier	EM26400	815221	Oct. 25, 2012	Oct. 24, 2013
High Speed Peak Power Meter	ML2495A	0842014	Apr. 28, 2012	Apr. 27, 2013
Power Sensor	MA2411B	0738404	Apr. 28, 2012	Apr. 27, 2013

- NOTE:**
1. The calibration interval of the above test instruments is 12 months and the calibrations are traceable to NML/ROC and NIST/USA.
 2. The calibration interval of the loop antenna is 24 months and the calibrations are traceable to NML/ROC and NIST/USA.
 3. The test was performed in HwaYa Chamber 4.
 4. The horn antenna and HP preamplifier (model: 8449B) are used only for the measurement of emission frequency above 1GHz if tested.
 5. The FCC Site Registration No. is 460141.
 6. The IC Site Registration No. is IC7450F-4.



A D T

4.1.3 TEST PROCEDURES

- a. The EUT was placed on the top of a rotating table 0.8 meters above the ground at a 3 meters semi-anechoic chamber. The table was rotated 360 degrees to determine the position of the highest radiation.
- b. The EUT was set 3 meters away from the interference-receiving antenna, which was mounted on the top of a variable-height antenna tower.
- c. The antenna is a broadband antenna, and its height is varied from one meter to four meters above the ground to determine the maximum value of the field strength. Both horizontal and vertical polarizations of the antenna are set to make the measurement.
- d. For each suspected emission, the EUT was arranged to its worst case and then the antenna was tuned to heights from 1 meter to 4 meters and the rotatable table was turned from 0 degrees to 360 degrees to find the maximum reading.
- e. The test-receiver system was set to Peak Detect Function and Specified Bandwidth with Maximum Hold Mode.
- f. If the emission level of the EUT in peak mode was lower than the limit specified, then testing could be stopped and the peak values of the EUT would be reported. Otherwise the emissions would be re-tested one by one using peak, quasi-peak or average method as specified and then reported in a data sheet.

NOTE:

1. The resolution bandwidth and video bandwidth of test receiver/spectrum analyzer is 120kHz for Quasi-peak detection at frequency below 1GHz.
2. The resolution bandwidth of test receiver/spectrum analyzer is 100kHz and video bandwidth is 300kHz for Peak detection at frequency above 1GHz.
3. The resolution bandwidth of test receiver/spectrum analyzer is 1MHz and the video bandwidth is 1kHz for Average detection (AV) at frequency above 1GHz.
4. All modes of operation were investigated and the worst-case emissions are reported.

4.1.4 DEVIATION FROM TEST STANDARD

No deviation.

4.1.5 TEST SETUP

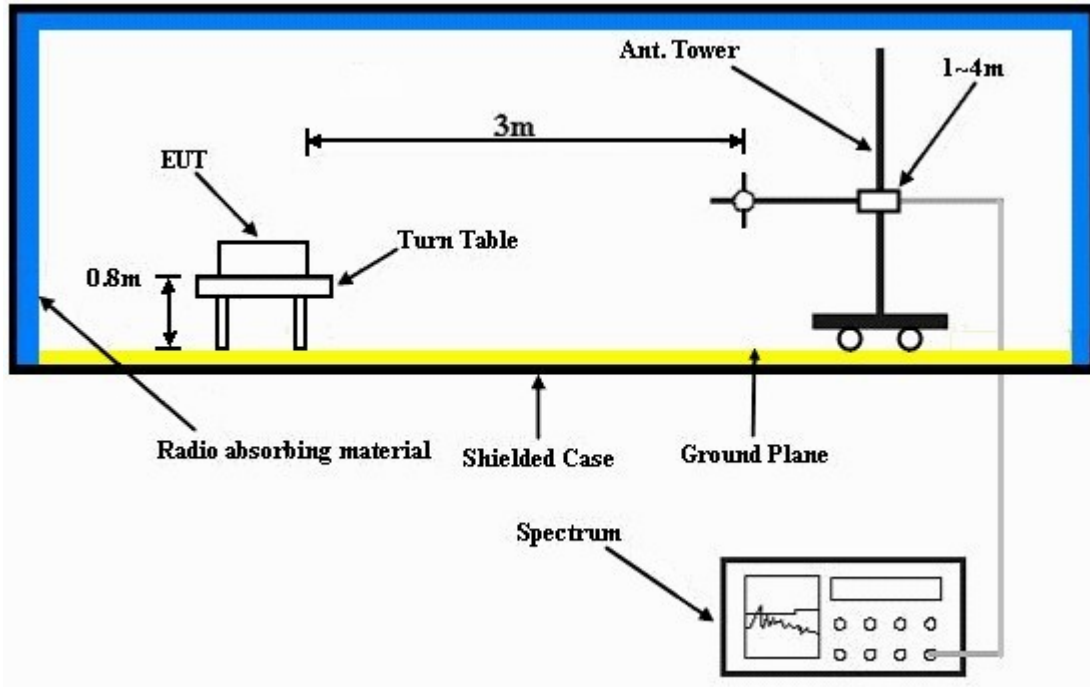

For the actual test configuration, please refer to the attached file (Test Setup Photo).

4.1.6 EUT OPERATING CONDITIONS

- Placed the EUT on the testing table.
- Prepared notebook to act as communication partner and placed it outside of testing area.
- The communication partner connected with EUT via a RJ45 cable and run a test program (provided by manufacturer) to enable EUT under transmission condition continuously at specific channel frequency.
- The communication partner sent data to EUT by command "PING".



A D T

4.1.7 TEST RESULTS

ABOVE 1GHZ DATA: 802.11a

EUT TEST CONDITION		MEASUREMENT DETAIL	
CHANNEL	Channel 149	FREQUENCY RANGE	1 ~ 40GHz
INPUT POWER (SYSTEM)	120Vac, 60 Hz	DETECTOR FUNCTION	Peak (PK) Average (AV)
ENVIRONMENTAL CONDITIONS	23deg. C, 66%RH	TESTED BY	Alan Wu

ANTENNA POLARITY & TEST DISTANCE: HORIZONTAL AT 3 M								
NO.	FREQ. (MHz)	EMISSION LEVEL (dBuV/m)	LIMIT (dBuV/m)	MARGIN (dB)	ANTENNA HEIGHT (m)	TABLE ANGLE (Degree)	RAW VALUE (dBuV)	CORRECTION FACTOR (dB/m)
1	#5725.00	79.0 PK	89.8	-10.8	1.42 H	235	39.50	39.50
2	#5725.00	68.5 AV	79.3	-10.8	1.42 H	235	29.00	39.50
3	*5745.00	109.8 PK			1.47 H	231	70.20	39.60
4	*5745.00	99.3 AV			1.47 H	231	59.70	39.60
5	11490.00	60.5 PK	74.0	-13.5	1.00 H	8	8.80	51.70
6	11490.00	46.7 AV	54.0	-7.3	1.00 H	8	-5.00	51.70
ANTENNA POLARITY & TEST DISTANCE: VERTICAL AT 3 M								
NO.	FREQ. (MHz)	EMISSION LEVEL (dBuV/m)	LIMIT (dBuV/m)	MARGIN (dB)	ANTENNA HEIGHT (m)	TABLE ANGLE (Degree)	RAW VALUE (dBuV)	CORRECTION FACTOR (dB/m)
1	#5725.00	91.8 PK	101.7	-9.9	1.11 V	21	52.30	39.50
2	#5725.00	81.2 AV	91.1	-9.9	1.11 V	21	41.70	39.50
3	*5745.00	121.7 PK			1.02 V	355	82.10	39.60
4	*5745.00	111.1 AV			1.02 V	355	71.50	39.60
5	11490.00	66.9 PK	74.0	-7.1	1.97 V	180	15.20	51.70
6	11490.00	52.5 AV	54.0	-1.5	1.97 V	180	0.80	51.70

REMARKS:

1. Emission level (dBuV/m) = Raw Value (dBuV) + Correction Factor (dB/m).
2. Correction Factor (dB/m) = Antenna Factor (dB/m) + Cable Factor (dB).
3. The other emission levels were very low against the limit.
4. Margin value = Emission level – Limit value.
5. “ * “: Fundamental frequency.
6. The limit value is defined as per 15.247.
7. "#":The radiated frequency is out the restricted band.



A D T

EUT TEST CONDITION		MEASUREMENT DETAIL	
CHANNEL	Channel 157	FREQUENCY RANGE	1 ~ 40GHz
INPUT POWER (SYSTEM)	120Vac, 60 Hz	DETECTOR FUNCTION	Peak (PK) Average (AV)
ENVIRONMENTAL CONDITIONS	23deg. C, 66%RH	TESTED BY	Alan Wu

ANTENNA POLARITY & TEST DISTANCE: HORIZONTAL AT 3 M								
NO.	FREQ. (MHz)	EMISSION LEVEL (dBuV/m)	LIMIT (dBuV/m)	MARGIN (dB)	ANTENNA HEIGHT (m)	TABLE ANGLE (Degree)	RAW VALUE (dBuV)	CORRECTION FACTOR (dB/m)
1	*5785.00	109.8 PK			1.00 H	26	70.10	39.70
2	*5785.00	99.8 AV			1.00 H	26	60.10	39.70
3	7713.00	53.7 PK	74.0	-20.3	1.00 H	35	8.50	45.20
4	7713.00	41.4 AV	54.0	-12.6	1.00 H	35	-3.80	45.20
5	11570.00	59.9 PK	74.0	-14.1	1.00 H	16	8.30	51.60
6	11570.00	46.5 AV	54.0	-7.5	1.00 H	16	-5.10	51.60
ANTENNA POLARITY & TEST DISTANCE: VERTICAL AT 3 M								
NO.	FREQ. (MHz)	EMISSION LEVEL (dBuV/m)	LIMIT (dBuV/m)	MARGIN (dB)	ANTENNA HEIGHT (m)	TABLE ANGLE (Degree)	RAW VALUE (dBuV)	CORRECTION FACTOR (dB/m)
1	*5785.00	121.7 PK			1.23 V	14	82.00	39.70
2	*5785.00	110.9 AV			1.23 V	14	71.20	39.70
3	7713.00	54.3 PK	74.0	-19.7	1.00 V	153	9.10	45.20
4	7713.00	42.2 AV	54.0	-11.8	1.00 V	153	-3.00	45.20
5	11570.00	65.4 PK	74.0	-8.6	1.28 V	161	13.80	51.60
6	11570.00	52.3 AV	54.0	-1.7	1.28 V	161	0.70	51.60

REMARKS:

1. Emission level (dBuV/m) = Raw Value (dBuV) + Correction Factor (dB/m).
2. Correction Factor (dB/m) = Antenna Factor (dB/m) + Cable Factor (dB).
3. The other emission levels were very low against the limit.
4. Margin value = Emission level – Limit value.
5. “ * ”: Fundamental frequency.
6. The limit value is defined as per 15.247.



A D T

EUT TEST CONDITION		MEASUREMENT DETAIL	
CHANNEL	Channel 165	FREQUENCY RANGE	1 ~ 40GHz
INPUT POWER (SYSTEM)	120Vac, 60 Hz	DETECTOR FUNCTION	Peak (PK) Average (AV)
ENVIRONMENTAL CONDITIONS	23deg. C, 66%RH	TESTED BY	Alan Wu

ANTENNA POLARITY & TEST DISTANCE: HORIZONTAL AT 3 M								
NO.	FREQ. (MHz)	EMISSION LEVEL (dBuV/m)	LIMIT (dBuV/m)	MARGIN (dB)	ANTENNA HEIGHT (m)	TABLE ANGLE (Degree)	RAW VALUE (dBuV)	CORRECTION FACTOR (dB/m)
1	*5825.00	108.7 PK			1.66 H	31	69.00	39.70
2	*5825.00	98.3 AV			1.66 H	31	58.60	39.70
3	#5850.00	72.7 PK	88.7	-16.0	1.66 H	33	32.90	39.80
4	#5850.00	62.3 AV	78.3	-16.0	1.66 H	33	22.50	39.80
5	11650.00	59.0 PK	74.0	-15.0	1.00 H	36	7.40	51.60
6	11650.00	46.7 AV	54.0	-7.3	1.00 H	36	-4.90	51.60
ANTENNA POLARITY & TEST DISTANCE: VERTICAL AT 3 M								
NO.	FREQ. (MHz)	EMISSION LEVEL (dBuV/m)	LIMIT (dBuV/m)	MARGIN (dB)	ANTENNA HEIGHT (m)	TABLE ANGLE (Degree)	RAW VALUE (dBuV)	CORRECTION FACTOR (dB/m)
1	*5825.00	120.2 PK			1.00 V	210	80.50	39.70
2	*5825.00	110.0 AV			1.00 V	210	70.30	39.70
3	#5850.00	84.7 PK	100.2	-15.5	1.00 V	176	44.90	39.80
4	#5850.00	74.5 AV	90.0	-15.5	1.00 V	176	34.70	39.80
5	11650.00	65.5 PK	74.0	-8.5	1.34 V	163	13.90	51.60
6	11650.00	52.5 AV	54.0	-1.5	1.34 V	163	0.90	51.60

REMARKS:

1. Emission level (dBuV/m) = Raw Value (dBuV) + Correction Factor (dB/m).
2. Correction Factor (dB/m) = Antenna Factor (dB/m) + Cable Factor (dB).
3. The other emission levels were very low against the limit.
4. Margin value = Emission level – Limit value.
5. “ * “: Fundamental frequency.
6. The limit value is defined as per 15.247.
7. "#":The radiated frequency is out the restricted band.



A D T

802.11n (20MHz)

EUT TEST CONDITION		MEASUREMENT DETAIL	
CHANNEL	Channel 149	FREQUENCY RANGE	1 ~ 40GHz
INPUT POWER (SYSTEM)	120Vac, 60 Hz	DETECTOR FUNCTION	Peak (PK) Average (AV)
ENVIRONMENTAL CONDITIONS	23deg. C, 66%RH	TESTED BY	Alan Wu

ANTENNA POLARITY & TEST DISTANCE: HORIZONTAL AT 3 M								
NO.	FREQ. (MHz)	EMISSION LEVEL (dBuV/m)	LIMIT (dBuV/m)	MARGIN (dB)	ANTENNA HEIGHT (m)	TABLE ANGLE (Degree)	RAW VALUE (dBuV)	CORRECTION FACTOR (dB/m)
1	#5725.00	86.4 PK	91.1	-4.7	1.00 H	16	46.90	39.50
2	#5725.00	74.3 AV	79.0	-4.7	1.00 H	16	34.80	39.50
3	*5745.00	111.1 PK			1.00 H	19	71.50	39.60
4	*5745.00	99.0 AV			1.00 H	19	59.40	39.60
5	11490.00	60.0 PK	74.0	-14.0	1.00 H	75	8.30	51.70
6	11490.00	47.8 AV	54.0	-6.2	1.00 H	75	-3.90	51.70
ANTENNA POLARITY & TEST DISTANCE: VERTICAL AT 3 M								
NO.	FREQ. (MHz)	EMISSION LEVEL (dBuV/m)	LIMIT (dBuV/m)	MARGIN (dB)	ANTENNA HEIGHT (m)	TABLE ANGLE (Degree)	RAW VALUE (dBuV)	CORRECTION FACTOR (dB/m)
1	#5725.00	98.6 PK	102.0	-3.4	1.03 V	1	59.10	39.50
2	#5725.00	86.6 AV	90.0	-3.4	1.03 V	1	47.10	39.50
3	*5745.00	122.0 PK			1.02 V	11	82.40	39.60
4	*5745.00	110.0 AV			1.02 V	11	70.40	39.60
5	11490.00	65.5 PK	74.0	-8.5	1.31 V	157	13.80	51.70
6	11490.00	52.6 AV	54.0	-1.4	1.31 V	157	0.90	51.70

REMARKS:

1. Emission level (dBuV/m) = Raw Value (dBuV) + Correction Factor (dB/m).
2. Correction Factor (dB/m) = Antenna Factor (dB/m) + Cable Factor (dB).
3. The other emission levels were very low against the limit.
4. Margin value = Emission level – Limit value.
5. “ * “: Fundamental frequency.
6. The limit value is defined as per 15.247.
7. "#":The radiated frequency is out the restricted band.



A D T

EUT TEST CONDITION		MEASUREMENT DETAIL	
CHANNEL	Channel 157	FREQUENCY RANGE	1 ~ 40GHz
INPUT POWER (SYSTEM)	120Vac, 60 Hz	DETECTOR FUNCTION	Peak (PK) Average (AV)
ENVIRONMENTAL CONDITIONS	23deg. C, 66%RH	TESTED BY	Alan Wu

ANTENNA POLARITY & TEST DISTANCE: HORIZONTAL AT 3 M								
NO.	FREQ. (MHz)	EMISSION LEVEL (dBuV/m)	LIMIT (dBuV/m)	MARGIN (dB)	ANTENNA HEIGHT (m)	TABLE ANGLE (Degree)	RAW VALUE (dBuV)	CORRECTION FACTOR (dB/m)
1	*5785.00	111.9 PK			1.55 H	30	72.20	39.70
2	*5785.00	99.4 AV			1.55 H	30	59.70	39.70
3	7713.00	54.1 PK	74.0	-19.9	1.00 H	25	8.90	45.20
4	7713.00	41.6 AV	54.0	-12.4	1.00 H	25	-3.60	45.20
5	11570.00	61.3 PK	74.0	-12.7	1.00 H	65	9.70	51.60
6	11570.00	47.1 AV	54.0	-6.9	1.00 H	65	-4.50	51.60
ANTENNA POLARITY & TEST DISTANCE: VERTICAL AT 3 M								
NO.	FREQ. (MHz)	EMISSION LEVEL (dBuV/m)	LIMIT (dBuV/m)	MARGIN (dB)	ANTENNA HEIGHT (m)	TABLE ANGLE (Degree)	RAW VALUE (dBuV)	CORRECTION FACTOR (dB/m)
1	*5785.00	121.2 PK			1.02 V	1	81.50	39.70
2	*5785.00	109.2 AV			1.02 V	1	69.50	39.70
3	7713.00	54.7 PK	74.0	-19.3	1.00 V	152	9.50	45.20
4	7713.00	42.4 AV	54.0	-11.6	1.00 V	152	-2.80	45.20
5	11570.00	66.7 PK	74.0	-7.3	1.41 V	156	15.10	51.60
6	11570.00	52.9 AV	54.0	-1.1	1.41 V	156	1.30	51.60

REMARKS:

1. Emission level (dBuV/m) = Raw Value (dBuV) + Correction Factor (dB/m).
2. Correction Factor (dB/m) = Antenna Factor (dB/m) + Cable Factor (dB).
3. The other emission levels were very low against the limit.
4. Margin value = Emission level – Limit value.
5. “ * ”: Fundamental frequency.
6. The limit value is defined as per 15.247.



A D T

EUT TEST CONDITION		MEASUREMENT DETAIL	
CHANNEL	Channel 165	FREQUENCY RANGE	1 ~ 40GHz
INPUT POWER (SYSTEM)	120Vac, 60 Hz	DETECTOR FUNCTION	Peak (PK) Average (AV)
ENVIRONMENTAL CONDITIONS	23deg. C, 66%RH	TESTED BY	Alan Wu

ANTENNA POLARITY & TEST DISTANCE: HORIZONTAL AT 3 M								
NO.	FREQ. (MHz)	EMISSION LEVEL (dBuV/m)	LIMIT (dBuV/m)	MARGIN (dB)	ANTENNA HEIGHT (m)	TABLE ANGLE (Degree)	RAW VALUE (dBuV)	CORRECTION FACTOR (dB/m)
1	*5825.00	110.6 PK			1.00 H	227	70.90	39.70
2	*5825.00	98.9 AV			1.00 H	227	59.20	39.70
3	#5850.00	82.5 PK	90.6	-8.1	1.00 H	221	42.70	39.80
4	#5850.00	70.8 AV	78.9	-8.1	1.00 H	221	31.00	39.80
5	11650.00	61.8 PK	74.0	-12.2	1.00 H	36	10.20	51.60
6	11650.00	47.0 AV	54.0	-7.0	1.00 H	36	-4.60	51.60
ANTENNA POLARITY & TEST DISTANCE: VERTICAL AT 3 M								
NO.	FREQ. (MHz)	EMISSION LEVEL (dBuV/m)	LIMIT (dBuV/m)	MARGIN (dB)	ANTENNA HEIGHT (m)	TABLE ANGLE (Degree)	RAW VALUE (dBuV)	CORRECTION FACTOR (dB/m)
1	*5825.00	120.9 PK			1.00 V	8	81.20	39.70
2	*5825.00	109.0 AV			1.00 V	8	69.30	39.70
3	#5850.00	93.5 PK	100.9	-7.4	1.00 V	358	53.70	39.80
4	#5850.00	81.6 AV	89.0	-7.4	1.00 V	358	41.80	39.80
5	11650.00	66.2 PK	74.0	-7.8	1.34 V	163	14.60	51.60
6	11650.00	52.8 AV	54.0	-1.2	1.34 V	163	1.20	51.60

REMARKS:

1. Emission level (dBuV/m) = Raw Value (dBuV) + Correction Factor (dB/m).
2. Correction Factor (dB/m) = Antenna Factor (dB/m) + Cable Factor (dB).
3. The other emission levels were very low against the limit.
4. Margin value = Emission level – Limit value.
5. “ * “: Fundamental frequency.
6. The limit value is defined as per 15.247.
7. "#":The radiated frequency is out the restricted band.



A D T

802.11n (40MHz)

EUT TEST CONDITION		MEASUREMENT DETAIL	
CHANNEL	Channel 151	FREQUENCY RANGE	1 ~ 40GHz
INPUT POWER (SYSTEM)	120Vac, 60 Hz	DETECTOR FUNCTION	Peak (PK) Average (AV)
ENVIRONMENTAL CONDITIONS	24deg. C, 72%RH	TESTED BY	Cedric Wu

ANTENNA POLARITY & TEST DISTANCE: HORIZONTAL AT 3 M								
NO.	FREQ. (MHz)	EMISSION LEVEL (dBuV/m)	LIMIT (dBuV/m)	MARGIN (dB)	ANTENNA HEIGHT (m)	TABLE ANGLE (Degree)	RAW VALUE (dBuV)	CORRECTION FACTOR (dB/m)
1	#5725.00	79.3 PK	84.3	-5.0	1.00 H	25	39.80	39.50
2	#5725.00	67.8 AV	72.8	-5.0	1.00 H	25	28.30	39.50
3	*5755.00	104.3 PK			1.00 H	22	64.70	39.60
4	*5755.00	92.8 AV			1.00 H	22	53.20	39.60
5	11510.00	60.0 PK	74.0	-14.0	1.00 H	70	8.30	51.70
6	11510.00	46.8 AV	54.0	-7.2	1.00 H	70	-4.90	51.70
ANTENNA POLARITY & TEST DISTANCE: VERTICAL AT 3 M								
NO.	FREQ. (MHz)	EMISSION LEVEL (dBuV/m)	LIMIT (dBuV/m)	MARGIN (dB)	ANTENNA HEIGHT (m)	TABLE ANGLE (Degree)	RAW VALUE (dBuV)	CORRECTION FACTOR (dB/m)
1	#5725.00	95.1 PK	96.8	-1.7	1.02 V	352	55.60	39.50
2	#5725.00	84.0 AV	85.7	-1.7	1.02 V	352	44.50	39.50
3	*5755.00	116.8 PK			1.02 V	359	77.20	39.60
4	*5755.00	105.7 AV			1.02 V	359	66.10	39.60
5	11510.00	62.9 PK	74.0	-11.1	1.30 V	162	11.20	51.70
6	11510.00	49.1 AV	54.0	-4.9	1.30 V	162	-2.60	51.70

REMARKS:

1. Emission level (dBuV/m) = Raw Value (dBuV) + Correction Factor (dB/m).
2. Correction Factor (dB/m) = Antenna Factor (dB/m) + Cable Factor (dB).
3. The other emission levels were very low against the limit.
4. Margin value = Emission level – Limit value.
5. “ * “: Fundamental frequency.
6. The limit value is defined as per 15.247.
7. "#":The radiated frequency is out the restricted band.



A D T

EUT TEST CONDITION		MEASUREMENT DETAIL	
CHANNEL	Channel 159	FREQUENCY RANGE	1 ~ 40GHz
INPUT POWER (SYSTEM)	120Vac, 60 Hz	DETECTOR FUNCTION	Peak (PK) Average (AV)
ENVIRONMENTAL CONDITIONS	24deg. C, 72%RH	TESTED BY	Cedric Wu

ANTENNA POLARITY & TEST DISTANCE: HORIZONTAL AT 3 M								
NO.	FREQ. (MHz)	EMISSION LEVEL (dBuV/m)	LIMIT (dBuV/m)	MARGIN (dB)	ANTENNA HEIGHT (m)	TABLE ANGLE (Degree)	RAW VALUE (dBuV)	CORRECTION FACTOR (dB/m)
1	*5795.00	104.8 PK			1.00 H	21	65.10	39.70
2	*5795.00	93.5 AV			1.00 H	21	53.80	39.70
3	#5850.00	76.2 PK	84.8	-8.6	1.00 H	29	36.40	39.80
4	#5850.00	65.0 AV	73.5	-8.5	1.00 H	29	25.20	39.80
5	11590.00	58.6 PK	74.0	-15.4	1.00 H	50	7.10	51.50
6	11590.00	46.5 AV	54.0	-7.5	1.00 H	50	-5.00	51.50
ANTENNA POLARITY & TEST DISTANCE: VERTICAL AT 3 M								
NO.	FREQ. (MHz)	EMISSION LEVEL (dBuV/m)	LIMIT (dBuV/m)	MARGIN (dB)	ANTENNA HEIGHT (m)	TABLE ANGLE (Degree)	RAW VALUE (dBuV)	CORRECTION FACTOR (dB/m)
1	*5795.00	115.7 PK			1.00 V	8	76.00	39.70
2	*5795.00	104.7 AV			1.00 V	8	65.00	39.70
3	#5850.00	84.1 PK	95.7	-11.6	1.00 V	3	44.30	39.80
4	#5850.00	73.1 AV	84.7	-11.6	1.00 V	3	33.30	39.80
5	11590.00	64.3 PK	74.0	-9.7	1.30 V	159	12.80	51.50
6	11590.00	49.6 AV	54.0	-4.4	1.30 V	159	-1.90	51.50

REMARKS:

1. Emission level (dBuV/m) = Raw Value (dBuV) + Correction Factor (dB/m).
2. Correction Factor (dB/m) = Antenna Factor (dB/m) + Cable Factor (dB).
3. The other emission levels were very low against the limit.
4. Margin value = Emission level – Limit value.
5. “ * “: Fundamental frequency.
6. The limit value is defined as per 15.247.
7. "#":The radiated frequency is out the restricted band.



A D T

BELOW 1GHz WORST-CASE DATA : 802.11n (20MHz)

EUT TEST CONDITION		MEASUREMENT DETAIL	
CHANNEL	Channel 159	FREQUENCY RANGE	Below 1000MHz
INPUT POWER (SYSTEM)	120Vac, 60 Hz	DETECTOR FUNCTION	Quasi-Peak
ENVIRONMENTAL CONDITIONS	26deg. C, 77%RH	TEST MODE	A
TESTED BY	Cedric Wu		

ANTENNA POLARITY & TEST DISTANCE: HORIZONTAL AT 3 M								
NO.	FREQ. (MHz)	EMISSION LEVEL (dBuV/m)	LIMIT (dBuV/m)	MARGIN (dB)	ANTENNA HEIGHT (m)	TABLE ANGLE (Degree)	RAW VALUE (dBuV)	CORRECTION FACTOR (dB/m)
1	29.90	34.3 QP	40.0	-5.7	1.24 H	187	34.30	0.00
2	299.62	43.1 QP	46.0	-2.9	1.00 H	4	28.40	14.70
3	375.29	41.3 QP	46.0	-4.7	1.00 H	126	24.70	16.60
4	433.50	41.2 QP	46.0	-4.8	1.00 H	150	23.30	17.90
5	499.48	44.0 QP	46.0	-2.0	1.75 H	155	24.50	19.50
6	625.60	43.8 QP	46.0	-2.2	1.49 H	51	22.10	21.70
ANTENNA POLARITY & TEST DISTANCE: VERTICAL AT 3 M								
NO.	FREQ. (MHz)	EMISSION LEVEL (dBuV/m)	LIMIT (dBuV/m)	MARGIN (dB)	ANTENNA HEIGHT (m)	TABLE ANGLE (Degree)	RAW VALUE (dBuV)	CORRECTION FACTOR (dB/m)
1	82.29	33.6 QP	40.0	-6.4	1.00 V	129	24.00	9.60
2	249.17	39.8 QP	46.0	-6.2	1.00 V	162	27.00	12.80
3	375.29	40.9 QP	46.0	-5.1	1.00 V	146	24.30	16.60
4	499.99	43.9 QP	46.0	-2.1	1.75 V	202	24.40	19.50
5	625.60	42.0 QP	46.0	-4.0	1.50 V	209	20.30	21.70
6	749.79	38.3 QP	46.0	-7.7	1.00 V	177	14.90	23.40

REMARKS:

1. Emission level (dBuV/m) = Raw Value (dBuV) + Correction Factor (dB/m).
2. Correction Factor (dB/m) = Antenna Factor (dB/m) + Cable Factor (dB).
3. The other emission levels were very low against the limit.
4. Margin value = Emission level – Limit value.



A D T

EUT TEST CONDITION		MEASUREMENT DETAIL	
CHANNEL	Channel 159	FREQUENCY RANGE	Below 1000MHz
INPUT POWER (SYSTEM)	120Vac, 60 Hz	DETECTOR FUNCTION	Quasi-Peak
ENVIRONMENTAL CONDITIONS	24deg. C, 72%RH	TEST MODE	B
TESTED BY	Cedric Wu		

ANTENNA POLARITY & TEST DISTANCE: HORIZONTAL AT 3 M								
NO.	FREQ. (MHz)	EMISSION LEVEL (dBuV/m)	LIMIT (dBuV/m)	MARGIN (dB)	ANTENNA HEIGHT (m)	TABLE ANGLE (Degree)	RAW VALUE (dBuV)	CORRECTION FACTOR (dB/m)
1	249.17	37.5 QP	46.0	-8.5	1.74 H	51	24.70	12.80
2	299.62	43.6 QP	46.0	-2.4	1.00 H	191	28.90	14.70
3	400.52	39.4 QP	46.0	-6.6	1.00 H	220	22.30	17.10
4	499.99	42.9 QP	46.0	-3.1	1.74 H	141	23.40	19.50
5	625.60	41.5 QP	46.0	-4.5	1.74 H	180	19.80	21.70
6	749.99	37.5 QP	46.0	-8.5	1.00 H	61	14.10	23.40
ANTENNA POLARITY & TEST DISTANCE: VERTICAL AT 3 M								
NO.	FREQ. (MHz)	EMISSION LEVEL (dBuV/m)	LIMIT (dBuV/m)	MARGIN (dB)	ANTENNA HEIGHT (m)	TABLE ANGLE (Degree)	RAW VALUE (dBuV)	CORRECTION FACTOR (dB/m)
1	105.58	33.0 QP	43.5	-10.5	1.00 V	203	23.00	10.00
2	249.17	37.5 QP	46.0	-8.5	1.00 V	114	24.70	12.80
3	363.65	36.1 QP	46.0	-9.9	1.00 V	138	19.80	16.30
4	499.48	42.3 QP	46.0	-3.7	1.00 V	225	22.80	19.50
5	625.60	43.2 QP	46.0	-2.8	1.50 V	191	21.50	21.70
6	749.79	36.7 QP	46.0	-9.3	1.00 V	186	13.30	23.40

REMARKS:

1. Emission level (dBuV/m) = Raw Value (dBuV) + Correction Factor (dB/m).
2. Correction Factor (dB/m) = Antenna Factor (dB/m) + Cable Factor (dB).
3. The other emission levels were very low against the limit.
4. Margin value = Emission level – Limit value.



A D T

EUT TEST CONDITION		MEASUREMENT DETAIL	
CHANNEL	Channel 159	FREQUENCY RANGE	Below 1000MHz
INPUT POWER (SYSTEM)	120Vac, 60 Hz	DETECTOR FUNCTION	Quasi-Peak
ENVIRONMENTAL CONDITIONS	24deg. C, 72%RH	TEST MODE	C
TESTED BY	Cedric Wu		

ANTENNA POLARITY & TEST DISTANCE: HORIZONTAL AT 3 M								
NO.	FREQ. (MHz)	EMISSION LEVEL (dBuV/m)	LIMIT (dBuV/m)	MARGIN (dB)	ANTENNA HEIGHT (m)	TABLE ANGLE (Degree)	RAW VALUE (dBuV)	CORRECTION FACTOR (dB/m)
1	249.17	40.7 QP	46.0	-5.3	1.24 H	68	27.90	12.80
2	299.62	43.7 QP	46.0	-2.3	1.00 H	205	29.00	14.70
3	350.07	41.2 QP	46.0	-4.8	1.00 H	199	25.20	16.00
4	375.29	42.9 QP	46.0	-3.1	1.00 H	50	26.30	16.60
5	499.48	40.4 QP	46.0	-5.6	1.74 H	231	20.90	19.50
6	625.60	43.3 QP	46.0	-2.7	1.24 H	39	21.60	21.70

ANTENNA POLARITY & TEST DISTANCE: VERTICAL AT 3 M								
NO.	FREQ. (MHz)	EMISSION LEVEL (dBuV/m)	LIMIT (dBuV/m)	MARGIN (dB)	ANTENNA HEIGHT (m)	TABLE ANGLE (Degree)	RAW VALUE (dBuV)	CORRECTION FACTOR (dB/m)
1	249.17	38.2 QP	46.0	-7.8	1.00 V	69	25.40	12.80
2	350.07	39.0 QP	46.0	-7.0	1.25 V	159	23.00	16.00
3	499.48	42.1 QP	46.0	-3.9	2.00 V	148	22.60	19.50
4	625.60	42.8 QP	46.0	-3.2	1.25 V	225	21.10	21.70
5	749.79	39.2 QP	46.0	-6.8	1.25 V	162	15.80	23.40
6	825.46	35.3 QP	46.0	-10.7	1.50 V	302	10.40	24.90

REMARKS:

1. Emission level (dBuV/m) = Raw Value (dBuV) + Correction Factor (dB/m).
2. Correction Factor (dB/m) = Antenna Factor (dB/m) + Cable Factor (dB).
3. The other emission levels were very low against the limit.
4. Margin value = Emission level – Limit value.



A D T

EUT TEST CONDITION		MEASUREMENT DETAIL	
CHANNEL	Channel 159	FREQUENCY RANGE	Below 1000MHz
INPUT POWER (SYSTEM)	120Vac, 60 Hz	DETECTOR FUNCTION	Quasi-Peak
ENVIRONMENTAL CONDITIONS	25deg. C, 65%RH	TEST MODE	D
TESTED BY	Alen Wu		

ANTENNA POLARITY & TEST DISTANCE: HORIZONTAL AT 3 M								
NO.	FREQ. (MHz)	EMISSION LEVEL (dBuV/m)	LIMIT (dBuV/m)	MARGIN (dB)	ANTENNA HEIGHT (m)	TABLE ANGLE (Degree)	RAW VALUE (dBuV)	CORRECTION FACTOR (dB/m)
1	249.17	43.2 QP	46.0	-2.8	1.50 H	253	30.40	12.80
2	375.29	41.4 QP	46.0	-4.6	1.00 H	73	24.80	16.60
3	499.48	43.5 QP	46.0	-2.5	1.75 H	124	24.00	19.50
4	600.38	40.0 QP	46.0	-6.0	1.50 H	126	18.40	21.60
5	625.60	43.2 QP	46.0	-2.8	1.50 H	207	21.50	21.70
6	749.79	38.4 QP	46.0	-7.6	1.99 H	123	15.00	23.40
ANTENNA POLARITY & TEST DISTANCE: VERTICAL AT 3 M								
NO.	FREQ. (MHz)	EMISSION LEVEL (dBuV/m)	LIMIT (dBuV/m)	MARGIN (dB)	ANTENNA HEIGHT (m)	TABLE ANGLE (Degree)	RAW VALUE (dBuV)	CORRECTION FACTOR (dB/m)
1	55.13	37.7 QP	40.0	-2.3	1.00 V	331	24.00	13.70
2	64.83	37.5 QP	40.0	-2.5	1.25 V	275	24.60	12.90
3	249.17	43.5 QP	46.0	-2.5	1.00 V	270	30.70	12.80
4	375.29	41.8 QP	46.0	-4.2	1.25 V	142	25.20	16.60
5	499.48	44.0 QP	46.0	-2.0	1.00 V	207	24.50	19.50
6	625.60	43.8 QP	46.0	-2.2	1.49 V	165	22.10	21.70

REMARKS:

1. Emission level (dBuV/m) = Raw Value (dBuV) + Correction Factor (dB/m).
2. Correction Factor (dB/m) = Antenna Factor (dB/m) + Cable Factor (dB).
3. The other emission levels were very low against the limit.
4. Margin value = Emission level – Limit value.



A D T

4.2 CONDUCTED EMISSION MEASUREMENT

4.2.1 LIMITS OF CONDUCTED EMISSION MEASUREMENT

FREQUENCY OF EMISSION (MHz)	CONDUCTED LIMIT (dBµV)	
	Quasi-peak	Average
0.15 ~ 0.5	66 to 56	56 to 46
0.5 ~ 5	56	46
5 ~ 30	60	50

- NOTE:**
1. The lower limit shall apply at the transition frequencies.
 2. The limit decreases in line with the logarithm of the frequency in the range of 0.15 to 0.50MHz.
 3. All emanations from a class A/B digital device or system, including any network of conductors and apparatus connected thereto, shall not exceed the level of field strengths specified above.

4.2.2 TEST INSTRUMENTS

TEST MODE A, B, C (Tested Date: Sep. 25 ~ Oct. 04, 2012)

DESCRIPTION & MANUFACTURER	MODEL NO.	SERIAL NO.	DATE OF CALIBRATION	DUE DATE OF CALIBRATION
Test Receiver ROHDE & SCHWARZ	ESCS30	100289	Nov. 19, 2011	Nov. 18, 2012
RF signal cable Woken	5D-FB	Cable-HYCO2-01	Dec. 29, 2011	Dec. 28, 2012
LISN ROHDE & SCHWARZ (EUT)	ESH2-Z5	100100	Dec. 30, 2011	Dec. 29, 2012
LISN ROHDE & SCHWARZ (Peripheral)	ESH3-Z5	100311	Jul. 06, 2012	Jul. 05, 2013
Software ADT	BV ADT_Cond_ V7.3.7.3	NA	NA	NA

- NOTE:**
1. The calibration interval of the above test instruments is 12 months and the calibrations are traceable to NML/ROC and NIST/USA.
 2. The test was performed in HwaYa Shielded Room 2.
 3. The VCCI Site Registration No. is C-2047.



A D T

TEST MODE A, B, D (Tested Date: Nov. 26, ~ Nov. 27, 2012)

DESCRIPTION & MANUFACTURER	MODEL NO.	SERIAL NO.	DATE OF CALIBRATION	DUE DATE OF CALIBRATION
Test Receiver ROHDE & SCHWARZ	ESCS30	100289	Nov. 19, 2012	Nov. 18, 2013
RF signal cable Woken	5D-FB	Cable-HYCO2-01	Dec. 29, 2011	Dec. 28, 2012
LISN ROHDE & SCHWARZ (EUT)	ESH2-Z5	100100	Dec. 30, 2011	Dec. 29, 2012
LISN ROHDE & SCHWARZ (Peripheral)	ESH3-Z5	100311	Jul. 06, 2012	Jul. 05, 2013
Software ADT	BV ADT_Cond_ V7.3.7.3	NA	NA	NA

- NOTE:** 1. The calibration interval of the above test instruments is 12 months and the calibrations are traceable to NML/ROC and NIST/USA.
2. The test was performed in HwaYa Shielded Room 2.
3. The VCCI Site Registration No. is C-2047.

4.2.3 TEST PROCEDURES

- a. The EUT was placed 0.4 meters from the conducting wall of the shielded room with EUT being connected to the power mains through a line impedance stabilization network (LISN). Other support units were connected to the power mains through another LISN. The two LISNs provide 50 ohm/ 50uH of coupling impedance for the measuring instrument.
- b. Both lines of the power mains connected to the EUT were checked for maximum conducted interference.
- c. The frequency range from 150kHz to 30MHz was searched. Emission levels under (Limit - 20dB) was not recorded.

NOTE: All modes of operation were investigated and the worst-case emissions are reported.

4.2.4 DEVIATION FROM TEST STANDARD

No deviation.

4.2.5 TEST SETUP

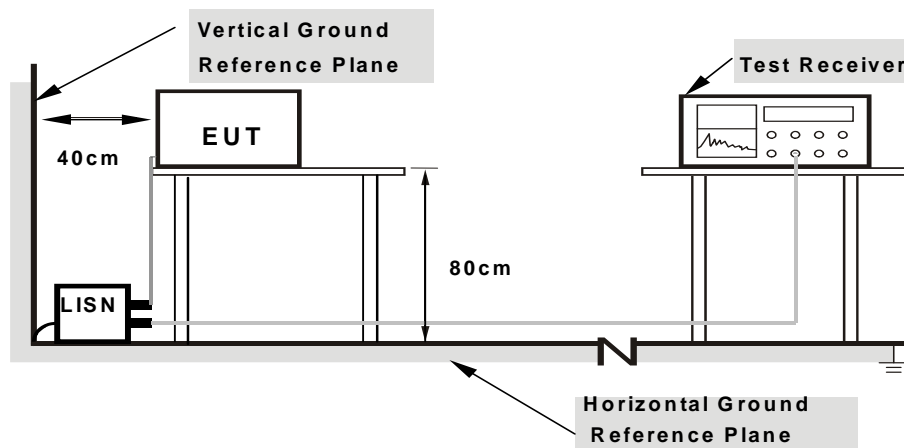

- Note:**
1. Support units were connected to second LISN.
 2. Both of LISNs (AMN) are 80 cm from EUT and at least 80 from other units and other metal planes

For the actual test configuration, please refer to the attached file (Test Setup Photo).

4.2.6 EUT OPERATING CONDITIONS

Same as 4.1.6

4.2.7 TEST RESULTS

CONDUCTED WORST-CASE DATA : 802.11n (20MHz)

PHASE	Line 1	6dB BANDWIDTH	9kHz
TEST MODE	A		

No	Freq. [MHz]	Corr. Factor (dB)	Reading Value		Emission Level		Limit		Margin	
			[dB (uV)]		[dB (uV)]		[dB (uV)]		(dB)	
			Q.P.	AV.	Q.P.	AV.	Q.P.	AV.	Q.P.	AV.
1	0.17734	0.17	46.29	29.51	46.46	29.68	64.61	54.61	-18.15	-24.93
2	0.26719	0.18	35.77	25.99	35.95	26.17	61.20	51.20	-25.25	-25.03
3	0.34531	0.18	32.75	24.90	32.93	25.08	59.07	49.07	-26.14	-23.99
4	0.73203	0.20	33.36	26.43	33.56	26.63	56.00	46.00	-22.44	-19.37
5	3.50391	0.35	30.85	27.87	31.20	28.22	56.00	46.00	-24.80	-17.78
6	28.68750	0.62	32.04	24.34	32.66	24.96	60.00	50.00	-27.34	-25.04

REMARKS:

1. Q.P. and AV. are abbreviations of quasi-peak and average individually.
2. The emission levels of other frequencies were very low against the limit.
3. Margin value = Emission level - Limit value
4. Correction factor = Insertion loss + Cable loss
5. Emission Level = Correction Factor + Reading Value.

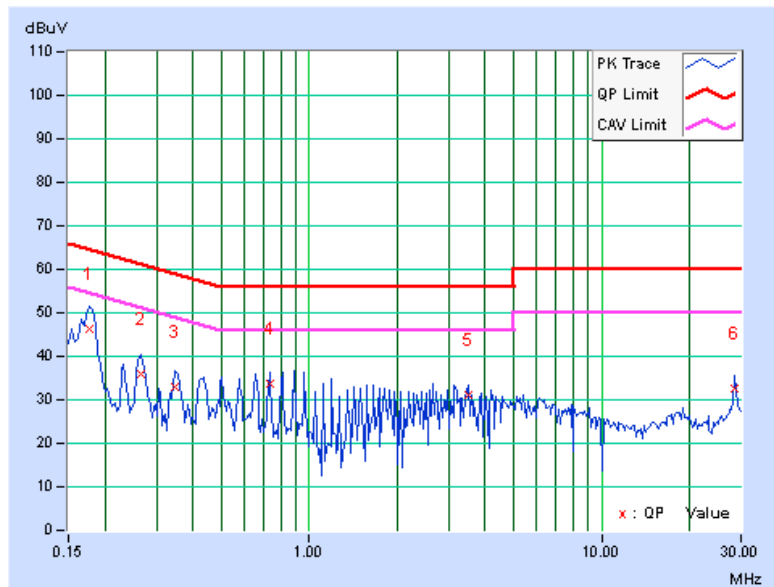



A D T

PHASE	Line 2	6dB BANDWIDTH	9kHz
TEST MODE	A		

No	Freq. [MHz]	Corr. Factor (dB)	Reading Value		Emission Level		Limit		Margin	
			[dB (uV)]		[dB (uV)]		[dB (uV)]		(dB)	
			Q.P.	AV.	Q.P.	AV.	Q.P.	AV.	Q.P.	AV.
1	0.17734	0.15	45.04	27.24	45.19	27.39	64.61	54.61	-19.42	-27.22
2	0.26719	0.16	35.39	27.85	35.55	28.01	61.20	51.20	-25.65	-23.19
3	0.50156	0.19	34.41	28.42	34.60	28.61	56.00	46.00	-21.40	-17.39
4	0.81016	0.21	33.84	29.48	34.05	29.69	56.00	46.00	-21.95	-16.31
5	2.57813	0.33	30.75	28.11	31.08	28.44	56.00	46.00	-24.92	-17.56
6	6.04688	0.46	28.36	25.11	28.82	25.57	60.00	50.00	-31.18	-24.43

REMARKS:

1. Q.P. and AV. are abbreviations of quasi-peak and average individually.
2. The emission levels of other frequencies were very low against the limit.
3. Margin value = Emission level - Limit value
4. Correction factor = Insertion loss + Cable loss
5. Emission Level = Correction Factor + Reading Value.

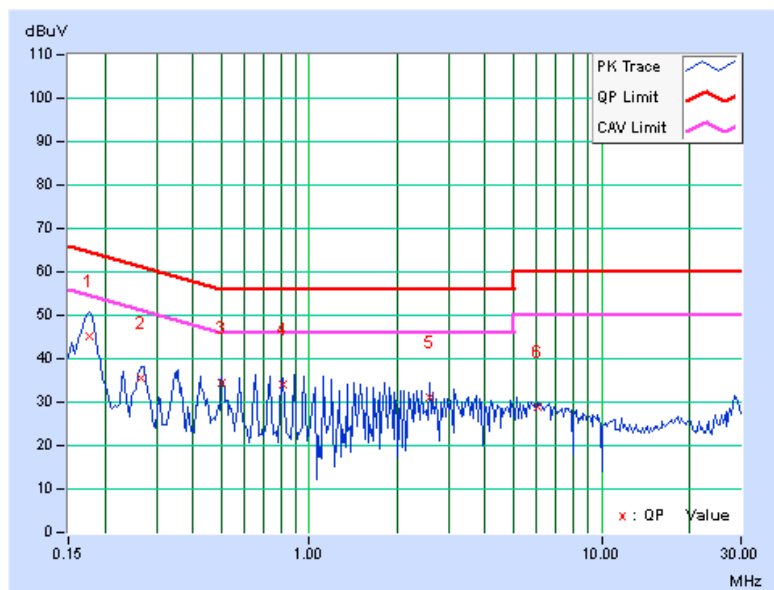

PHASE	Line 1	6dB BANDWIDTH	9kHz
TEST MODE	B		

No	Freq. [MHz]	Corr. Factor (dB)	Reading Value		Emission Level		Limit		Margin	
			[dB (uV)]		[dB (uV)]		[dB (uV)]		(dB)	
			Q.P.	AV.	Q.P.	AV.	Q.P.	AV.	Q.P.	AV.
1	0.16837	0.17	56.12	37.74	56.29	37.91	65.04	55.04	-8.75	-17.13
2	0.24766	0.18	42.39	28.35	42.57	28.53	61.84	51.84	-19.27	-23.31
3	0.83359	0.20	36.72	23.52	36.92	23.72	56.00	46.00	-19.08	-22.28
4	1.60547	0.26	36.75	24.16	37.01	24.42	56.00	46.00	-18.99	-21.58
5	8.90234	0.47	30.12	23.50	30.59	23.97	60.00	50.00	-29.41	-26.03
6	18.36719	0.68	32.77	27.44	33.45	28.12	60.00	50.00	-26.55	-21.88

REMARKS:

1. Q.P. and AV. are abbreviations of quasi-peak and average individually.
2. The emission levels of other frequencies were very low against the limit.
3. Margin value = Emission level - Limit value
4. Correction factor = Insertion loss + Cable loss
5. Emission Level = Correction Factor + Reading Value.

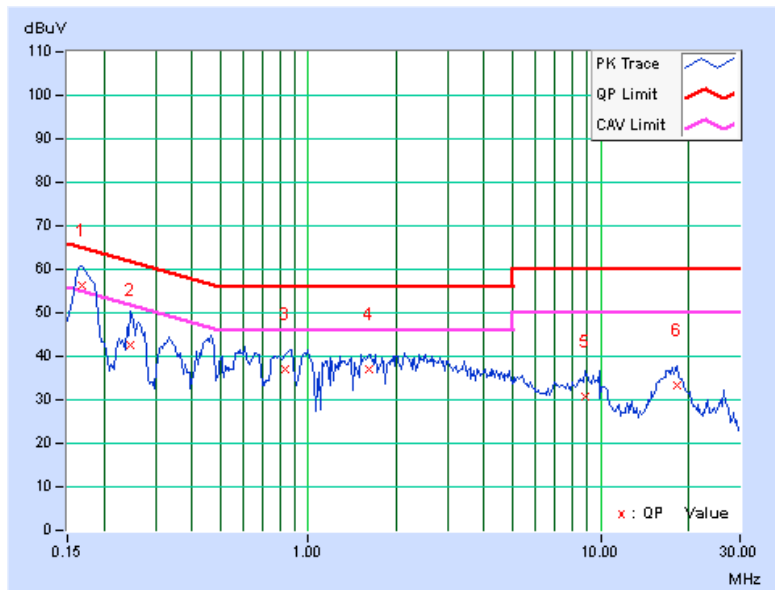

PHASE	Line 2	6dB BANDWIDTH	9kHz
TEST MODE	B		

No	Freq. [MHz]	Corr. Factor (dB)	Reading Value		Emission Level		Limit		Margin	
			[dB (uV)]		[dB (uV)]		[dB (uV)]		(dB)	
			Q.P.	AV.	Q.P.	AV.	Q.P.	AV.	Q.P.	AV.
1	0.17083	0.14	56.18	38.94	56.32	39.08	64.92	54.92	-8.60	-15.84
2	0.24894	0.16	43.37	27.27	43.53	27.43	61.79	51.79	-18.27	-24.37
3	0.44688	0.18	39.66	30.20	39.84	30.38	56.93	46.93	-17.09	-16.55
4	0.85703	0.21	36.67	24.06	36.88	24.27	56.00	46.00	-19.12	-21.73
5	6.75391	0.48	31.35	22.63	31.83	23.11	60.00	50.00	-28.17	-26.89
6	17.92188	0.76	32.15	26.48	32.91	27.24	60.00	50.00	-27.09	-22.76

REMARKS:

1. Q.P. and AV. are abbreviations of quasi-peak and average individually.
2. The emission levels of other frequencies were very low against the limit.
3. Margin value = Emission level - Limit value
4. Correction factor = Insertion loss + Cable loss
5. Emission Level = Correction Factor + Reading Value.

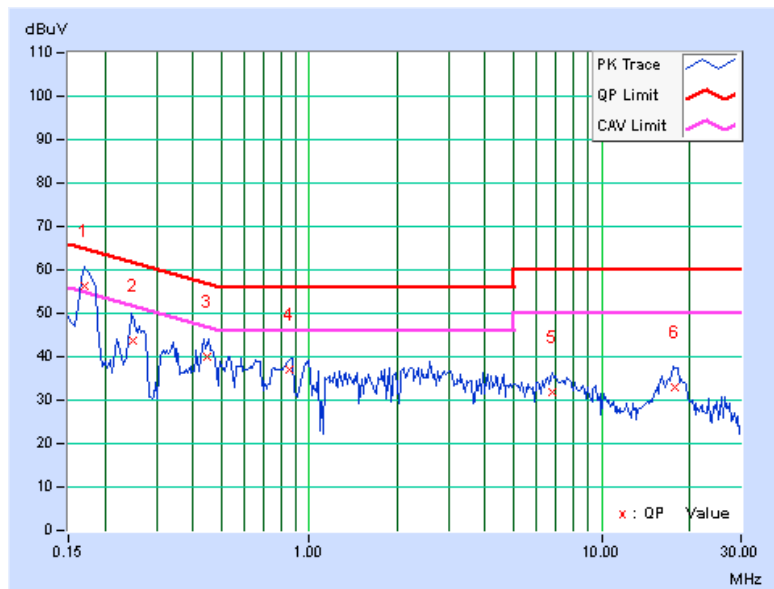



A D T

PHASE	Line 1	6dB BANDWIDTH	9kHz
TEST MODE	C		

No	Freq. [MHz]	Corr. Factor (dB)	Reading Value		Emission Level		Limit		Margin	
			[dB (uV)]		[dB (uV)]		[dB (uV)]		(dB)	
			Q.P.	AV.	Q.P.	AV.	Q.P.	AV.	Q.P.	AV.
1	0.17344	0.17	63.20	41.26	63.37	41.43	64.79	54.79	-1.42	-13.36
2	0.25547	0.18	56.24	34.18	56.42	34.36	61.58	51.58	-5.16	-17.22
3	0.62656	0.19	36.45	20.52	36.64	20.71	56.00	46.00	-19.36	-25.29
4	0.92344	0.21	30.90	15.67	31.11	15.88	56.00	46.00	-24.89	-30.12
5	1.20313	0.23	27.17	13.68	27.40	13.91	56.00	46.00	-28.60	-32.09
6	9.82813	0.49	29.45	24.06	29.94	24.55	60.00	50.00	-30.06	-25.45

REMARKS:

1. Q.P. and AV. are abbreviations of quasi-peak and average individually.
2. The emission levels of other frequencies were very low against the limit.
3. Margin value = Emission level - Limit value
4. Correction factor = Insertion loss + Cable loss
5. Emission Level = Correction Factor + Reading Value.

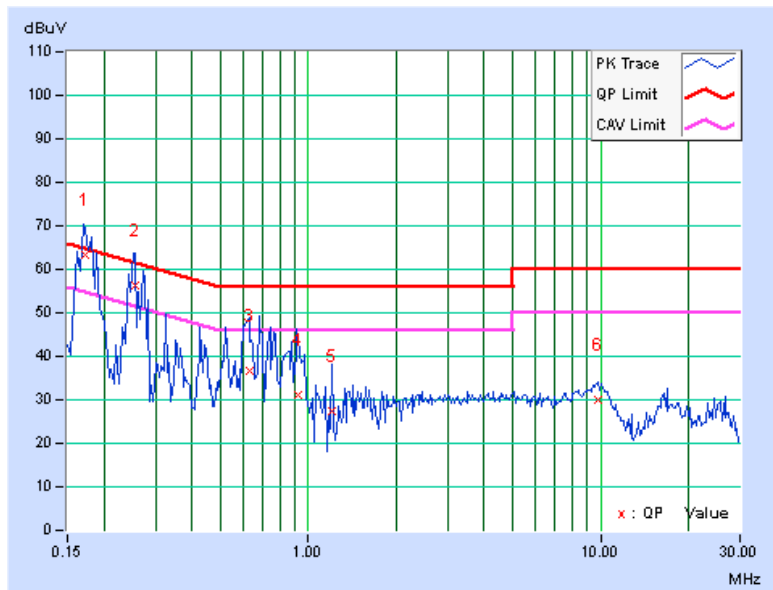



A D T

PHASE	Line 2	6dB BANDWIDTH	9kHz
TEST MODE	C		

No	Freq. [MHz]	Corr. Factor (dB)	Reading Value		Emission Level		Limit		Margin	
			[dB (uV)]		[dB (uV)]		[dB (uV)]		(dB)	
			Q.P.	AV.	Q.P.	AV.	Q.P.	AV.	Q.P.	AV.
1	0.16562	0.14	63.50	37.34	63.64	37.48	65.18	55.18	-1.53	-17.69
2	0.24766	0.16	55.67	34.59	55.83	34.75	61.84	51.84	-6.01	-17.09
3	0.33359	0.17	39.39	17.34	39.56	17.51	59.36	49.36	-19.80	-31.85
4	0.59141	0.19	39.18	18.60	39.37	18.79	56.00	46.00	-16.63	-27.21
5	0.76328	0.20	36.83	16.37	37.03	16.57	56.00	46.00	-18.97	-29.43
6	9.44922	0.56	28.59	23.02	29.15	23.58	60.00	50.00	-30.85	-26.42

REMARKS:

1. Q.P. and AV. are abbreviations of quasi-peak and average individually.
2. The emission levels of other frequencies were very low against the limit.
3. Margin value = Emission level - Limit value
4. Correction factor = Insertion loss + Cable loss
5. Emission Level = Correction Factor + Reading Value.

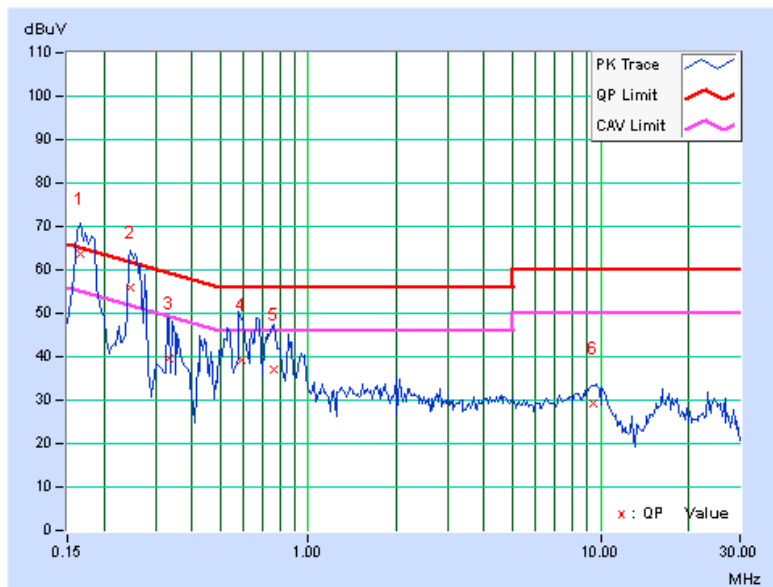



A D T

PHASE	Line 1	6dB BANDWIDTH	9kHz
TEST MODE	D		

No	Freq. [MHz]	Corr. Factor (dB)	Reading Value		Emission Level		Limit		Margin	
			[dB (uV)]		[dB (uV)]		[dB (uV)]		(dB)	
			Q.P.	AV.	Q.P.	AV.	Q.P.	AV.	Q.P.	AV.
1	0.18508	0.22	50.86	46.92	51.08	47.14	64.25	54.25	-13.18	-7.12
2	0.28294	0.23	39.99	29.14	40.22	29.37	60.73	50.73	-20.51	-21.36
3	0.36334	0.24	37.23	28.21	37.47	28.45	58.65	48.65	-21.19	-20.21
4	1.11186	0.31	38.87	28.44	39.18	28.75	56.00	46.00	-16.82	-17.25
5	1.75638	0.33	35.32	21.28	35.65	21.61	56.00	46.00	-20.35	-24.39
6	3.06686	0.39	33.97	16.74	34.36	17.13	56.00	46.00	-21.64	-28.87

REMARKS:

1. Q.P. and AV. are abbreviations of quasi-peak and average individually.
2. The emission levels of other frequencies were very low against the limit.
3. Margin value = Emission level - Limit value
4. Correction factor = Insertion loss + Cable loss
5. Emission Level = Correction Factor + Reading Value.

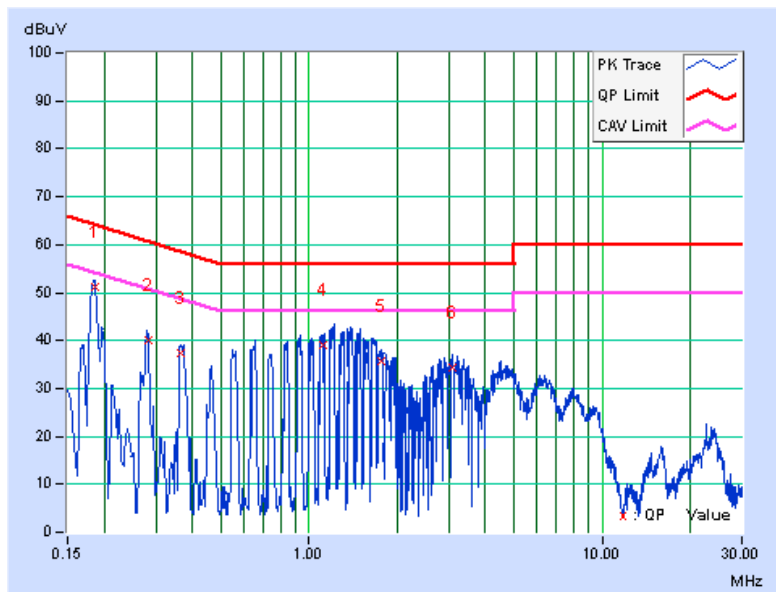



A D T

PHASE	Line 2	6dB BANDWIDTH	9kHz
TEST MODE	D		

No	Freq.	Corr. Factor	Reading Value		Emission Level		Limit		Margin	
	[MHz]		[dB (uV)]		[dB (uV)]		[dB (uV)]		(dB)	
			Q.P.	AV.	Q.P.	AV.	Q.P.	AV.	Q.P.	AV.
1	0.18910	0.20	52.53	46.20	52.73	46.40	64.08	54.08	-11.34	-7.67
2	0.37287	0.22	42.03	38.94	42.25	39.16	58.44	48.44	-16.19	-9.28
3	0.64362	0.24	39.76	32.59	40.00	32.83	56.00	46.00	-16.00	-13.17
4	1.19865	0.28	41.75	30.24	42.03	30.52	56.00	46.00	-13.97	-15.48
5	1.67099	0.30	38.96	25.52	39.26	25.82	56.00	46.00	-16.74	-20.18
6	3.07468	0.37	35.63	18.49	36.00	18.86	56.00	46.00	-20.00	-27.14

REMARKS:

1. Q.P. and AV. are abbreviations of quasi-peak and average individually.
2. The emission levels of other frequencies were very low against the limit.
3. Margin value = Emission level - Limit value
4. Correction factor = Insertion loss + Cable loss
5. Emission Level = Correction Factor + Reading Value.

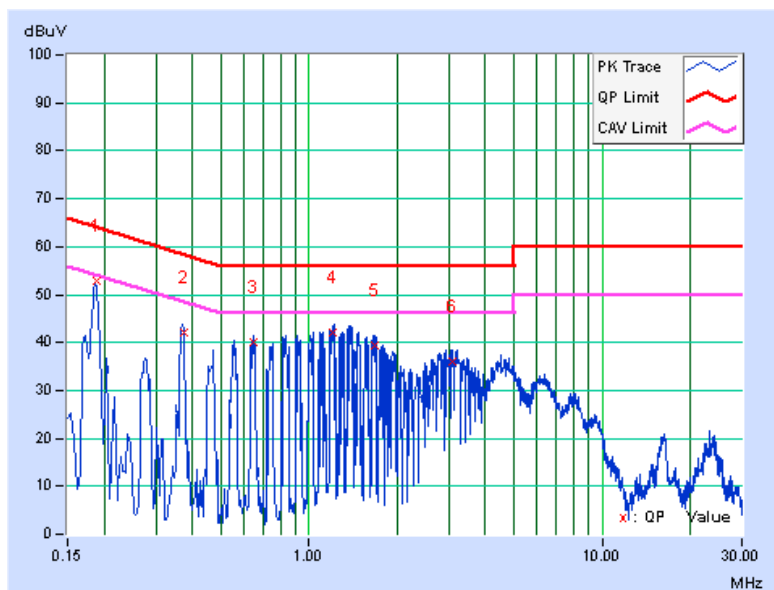

4.3 6dB BANDWIDTH MEASUREMENT

4.3.1 LIMITS OF 6dB BANDWIDTH MEASUREMENT

The minimum of 6dB Bandwidth Measurement is 0.5MHz.

4.3.2 TEST SETUP

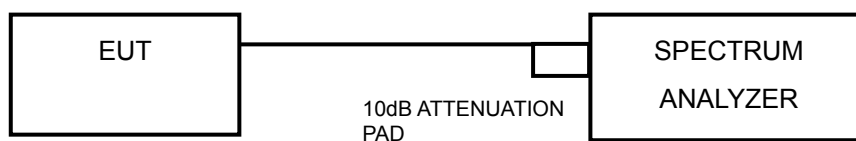

4.3.3 TEST INSTRUMENTS

Refer to section 4.1.2 to get information of above instrument.

4.3.4 TEST PROCEDURE

- a. Set resolution bandwidth (RBW) = approximately 1% of the emission bandwidth
- b. Set the video bandwidth (VBW) $\geq 3 \times$ RBW, Detector = Peak.
- c. Trace mode = max hold.
- d. Sweep = auto couple.
- e. Measure the maximum width of the emission that is constrained by the frequencies associated with the two amplitude points (upper and lower) that are attenuated by 6 dB relative to the maximum level measured in the fundamental emission

4.3.5 DEVIATION FROM TEST STANDARD

No deviation.

4.3.6 EUT OPERATING CONDITIONS

The software provided by client to enable the EUT under transmission condition continuously at lowest, middle and highest channel frequencies individually.



A D T

4.3.7 TEST RESULTS

802.11a

CHANNEL	FREQUENCY (MHz)	6dB BANDWIDTH (MHz)		MINIMUM LIMIT (MHz)	PASS / FAIL
		CHAIN 0	CHAIN 1		
149	5745	16.53	16.56	0.5	PASS
157	5785	16.52	16.54	0.5	PASS
165	5825	16.48	16.51	0.5	PASS

802.11n (20MHz)

CHANNEL	FREQUENCY (MHz)	6dB BANDWIDTH (MHz)		MINIMUM LIMIT (MHz)	PASS / FAIL
		CHAIN 0	CHAIN 1		
149	5745	17.61	17.64	0.5	PASS
157	5785	17.63	17.63	0.5	PASS
165	5825	17.61	17.62	0.5	PASS

802.11n (40MHz)

CHANNEL	FREQUENCY (MHz)	6dB BANDWIDTH (MHz)		MINIMUM LIMIT (MHz)	PASS / FAIL
		CHAIN 0	CHAIN 1		
151	5755	35.89	36.45	0.5	PASS
159	5795	35.87	36.46	0.5	PASS

4.4 CONDUCTED OUTPUT POWER

4.4.1 LIMITS OF CONDUCTED OUTPUT POWER MEASUREMENT

For systems using digital modulation in the 5725 –5850 MHz bands: 1 Watt (30dBm)

Per KDB 662911 D01 Multiple Transmitter Output v01r02 Method of conducted output power measurement on IEEE 802.11 devices,

Array Gain = 0 dB (i.e., no array gain) for NANT \leq 4;

Array Gain = 0 dB (i.e., no array gain) for channel widths \geq 40 MHz for any NANT;

Array Gain = $5 \log(\text{NANT}/\text{NSS})$ dB or 3 dB, whichever is less for 20-MHz channel widths with NANT \geq 5.

For power measurements on all other devices: Array Gain = $10 \log(\text{NANT}/\text{NSS})$ dB.

4.4.2 TEST SETUP

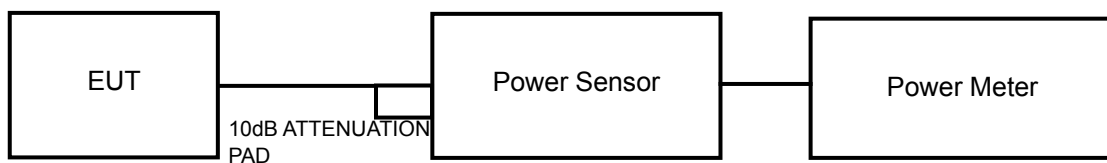

4.4.3 TEST INSTRUMENTS

Refer to section 4.1.2 to get information of above instrument.

4.4.4 TEST PROCEDURES

A peak / average power sensor were used on the output port of the EUT. A power meter was used to read the response of the peak / average power sensor. Record the power level.



A D T

4.4.5 DEVIATION FROM TEST STANDARD

No deviation.

4.4.6 EUT OPERATING CONDITIONS

Same as Item 4.3.6.



A D T

4.4.7 TEST RESULTS

FOR PEAK POWER

802.11a

CHAN.	FREQ. (MHz)	PEAK POWER (dBm)		TOTAL POWER (mW)	TOTAL POWER (dBm)	LIMIT (dBm)	PASS / FAIL
		CHAIN 0	CHAIN 1				
149	5745	23.95	24.03	501.24	27.00	30	PASS
157	5785	24.07	24.14	514.69	27.12	30	PASS
165	5825	23.95	23.93	495.49	26.95	30	PASS

802.11n (20MHz)

CHAN.	FREQ. (MHz)	PEAK POWER (dBm)		TOTAL POWER (mW)	TOTAL POWER (dBm)	LIMIT (dBm)	PASS / FAIL
		CHAIN 0	CHAIN 1				
149	5745	24.06	24.20	517.71	27.14	30	PASS
157	5785	24.04	24.11	511.14	27.09	30	PASS
165	5825	23.93	24.02	499.52	26.99	30	PASS

802.11n (40MHz)

CHAN.	FREQ. (MHz)	PEAK POWER (dBm)		TOTAL POWER (mW)	TOTAL POWER (dBm)	LIMIT (dBm)	PASS / FAIL
		CHAIN 0	CHAIN 1				
151	5755	23.91	23.90	491.51	26.92	30	PASS
159	5795	23.95	23.97	497.77	26.97	30	PASS



A D T

FOR AVERAGE POWER

802.11a

CHAN.	FREQ. (MHz)	PEAK POWER (dBm)		TOTAL POWER (mW)	TOTAL POWER (dBm)
		CHAIN 0	CHAIN 1		
149	5745	19.89	20.26	203.704	23.09
157	5785	22.01	20.61	274.157	24.38
165	5825	19.68	20.71	210.863	23.24

802.11n (20MHz)

CHAN.	FREQ. (MHz)	PEAK POWER (dBm)		TOTAL POWER (mW)	TOTAL POWER (dBm)
		CHAIN 0	CHAIN 1		
149	5745	21.15	21.51	271.644	24.34
157	5785	21.72	21.89	303.389	24.82
165	5825	21.56	21.91	298.538	24.75

802.11n (40MHz)

CHAN.	FREQ. (MHz)	PEAK POWER (dBm)		TOTAL POWER (mW)	TOTAL POWER (dBm)
		CHAIN 0	CHAIN 1		
151	5755	20.93	21.37	261.216	24.17
159	5795	21.90	22.29	324.340	25.11

4.5 POWER SPECTRAL DENSITY MEASUREMENT

4.5.1 LIMITS OF POWER SPECTRAL DENSITY MEASUREMENT

The Maximum of Power Spectral Density Measurement is 8dBm.

4.5.2 TEST SETUP

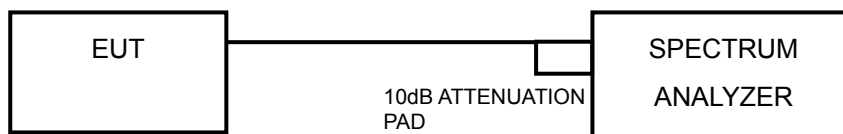

4.5.3 TEST INSTRUMENTS

Refer to section 4.1.2 to get information of above instrument.

4.5.4 TEST PROCEDURE

- a. Set the RBW = 100 kHz, VBW = 300 kHz, Detector = peak.
- b. Sweep time = auto couple, Trace mode = max hold, allow trace to fully stabilize.
- c. Use the peak marker function to determine the maximum power level in any 100 kHz band segment within the fundamental EBW.
- d. Scale the observed power level to an equivalent value in 3 kHz by adjusting (reducing) the measured power by a bandwidth correction factor (BWCF) where $BWCF = 10\log(3 \text{ kHz}/100\text{kHz})$

4.5.5 DEVIATION FROM TEST STANDARD

No deviation.

4.5.6 EUT OPERATING CONDITION

Same as Item 4.3.6.



A D T

4.5.7 TEST RESULTS

802.11a

TX chain	Channel	Freq. (MHz)	PSD (dBm/3kHz)	10 log (N=2) dB	Total PSD (dBm/3kHz)	Limit (dBm/3kHz)	PASS /FAIL
0	149	5745	-0.65	3.01	2.36	8	PASS
	157	5785	-2.15	3.01	0.86	8	PASS
	165	5825	2.72	3.01	5.73	8	PASS
1	149	5745	-5.83	3.01	-2.82	8	PASS
	157	5785	-5.35	3.01	-2.34	8	PASS
	165	5825	-4.52	3.01	-1.51	8	PASS

NOTE: Directional gain = $0.4\text{dBi} + 10\log(2) = 3.41\text{dBi} < 6\text{dBi}$, so the limit no need to reduced.

802.11n (20MHz)

TX chain	Channel	Freq. (MHz)	PSD (dBm/3kHz)	10 log (N=2) dB	Total PSD (dBm/3kHz)	Limit (dBm/3kHz)	PASS /FAIL
0	149	5745	2.54	3.01	5.55	8	PASS
	157	5785	4.87	3.01	7.88	8	PASS
	165	5825	4.72	3.01	7.73	8	PASS
1	149	5745	-6.24	3.01	-3.23	8	PASS
	157	5785	-5.90	3.01	-2.89	8	PASS
	165	5825	-3.73	3.01	-0.72	8	PASS

NOTE: Directional gain = $0.4\text{dBi} + 10\log(2) = 3.41\text{dBi} < 6\text{dBi}$, so the limit no need to reduced.

802.11n (40MHz)

TX chain	Channel	Freq. (MHz)	PSD (dBm/3kHz)	10 log (N=2) dB	Total PSD (dBm/3kHz)	Limit (dBm/3kHz)	PASS /FAIL
0	151	5755	4.67	3.01	7.68	8	PASS
	159	5795	4.74	3.01	7.75	8	PASS
1	151	5755	-8.52	3.01	-5.51	8	PASS
	159	5795	-5.36	3.01	-2.35	8	PASS

NOTE: Directional gain = $0.4\text{dBi} + 10\log(2) = 3.41\text{dBi} < 6\text{dBi}$, so the limit no need to reduced.

4.6 CONDUCTED OUT OF BAND EMISSION MEASUREMENT

4.6.1 LIMITS OF CONDUCTED OUT OF BAND EMISSION MEASUREMENT

Below -20dB of the highest emission level of operating band (in 100kHz Resolution Bandwidth).

4.6.2 TEST SETUP

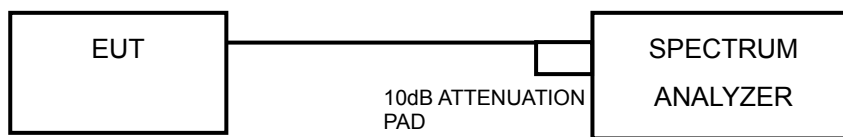

4.6.3 TEST INSTRUMENTS

Refer to section 4.1.2 to get information of above instrument.

4.6.4 TEST PROCEDURE

MEASUREMENT PROCEDURE REF

1. Set the RBW = 100 kHz.
2. Set the VBW \geq 300 kHz.
3. Detector = peak.
4. Sweep time = auto couple.
5. Trace mode = max hold.
6. Allow trace to fully stabilize.
7. Use the peak marker function to determine the maximum power level in any 100 kHz band segment within the fundamental EBW.



A D T

MEASUREMENT PROCEDURE OOB

1. Set RBW = 100 kHz.
2. Set VBW \geq 300 kHz.
3. Set span to encompass the spectrum to be examined.
4. Detector = peak.
5. Trace Mode = max hold.
6. Sweep = auto couple.

4.6.5 DEVIATION FROM TEST STANDARD

No deviation.

4.6.6 EUT OPERATING CONDITION

Same as Item 4.3.6

4.6.7 TEST RESULTS

The spectrum plots are attached on the following pages. D1 line indicates the highest level, and D2 line indicates the 20dB offset below D1. It shows compliance with the requirement.

802.11a

CH 149

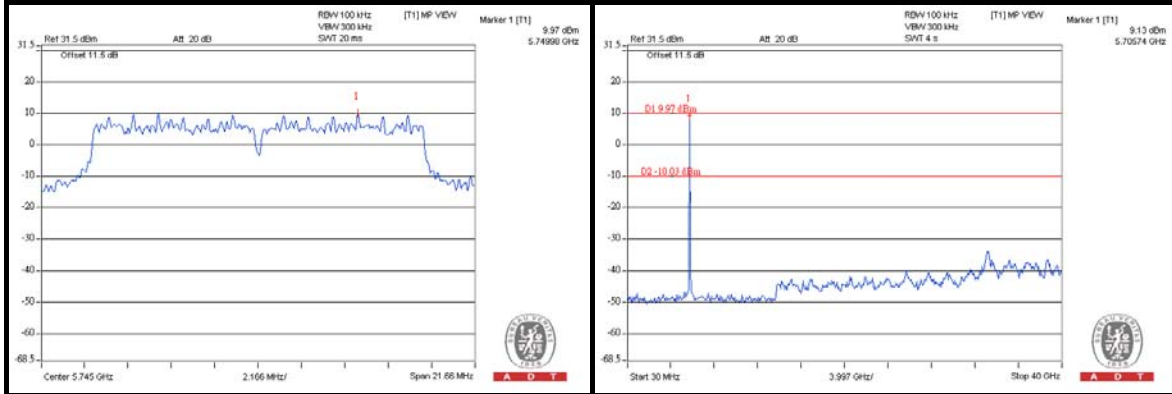

CH 157

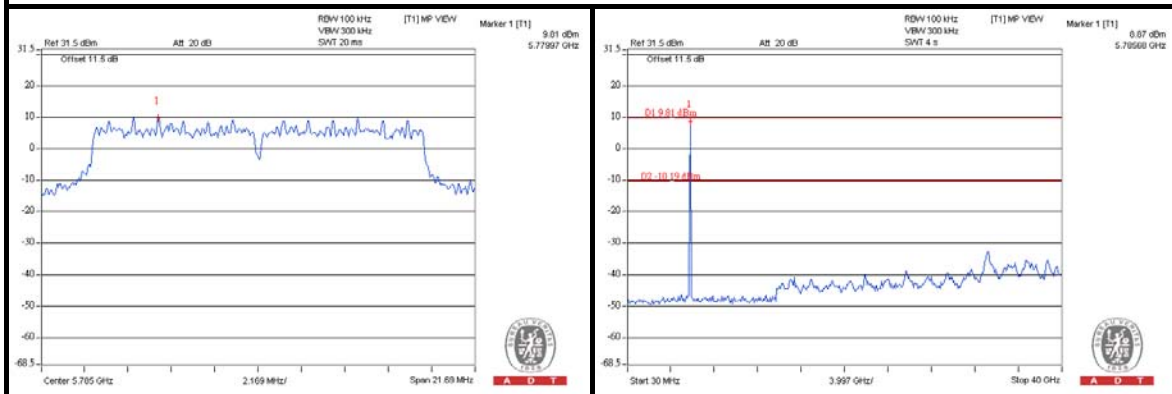

CH 165

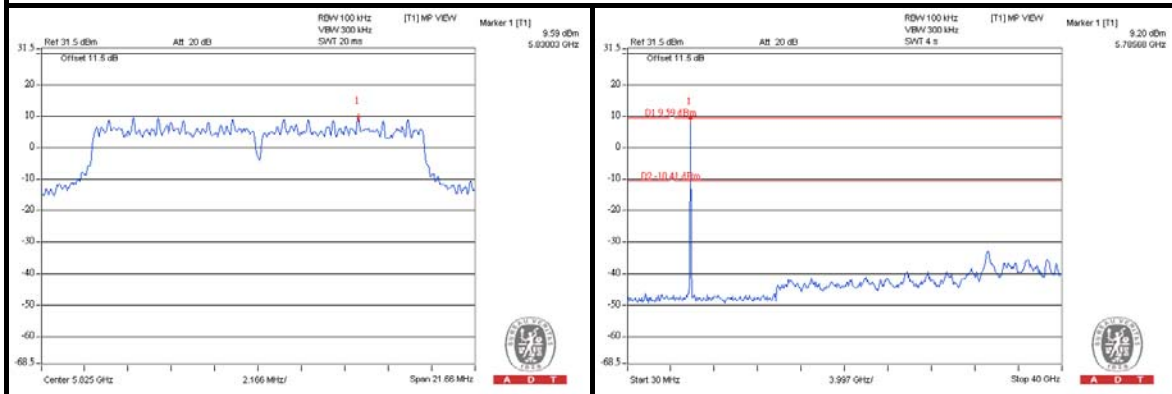

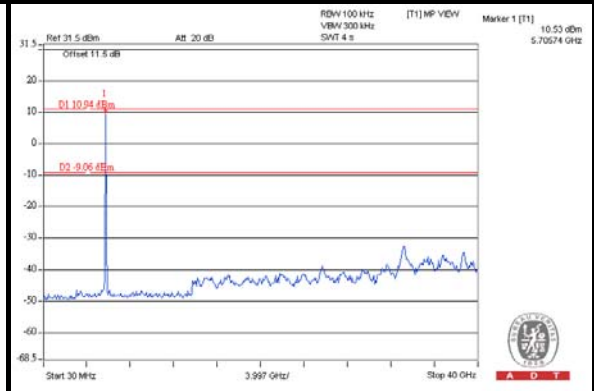
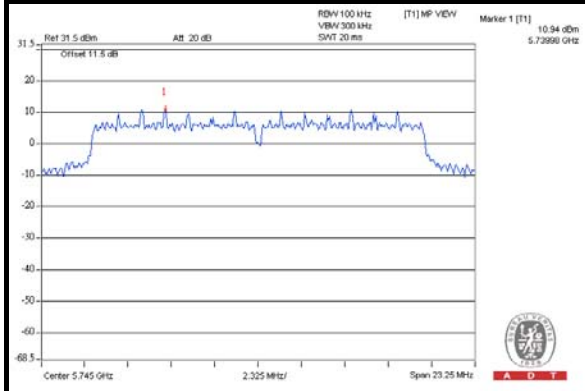
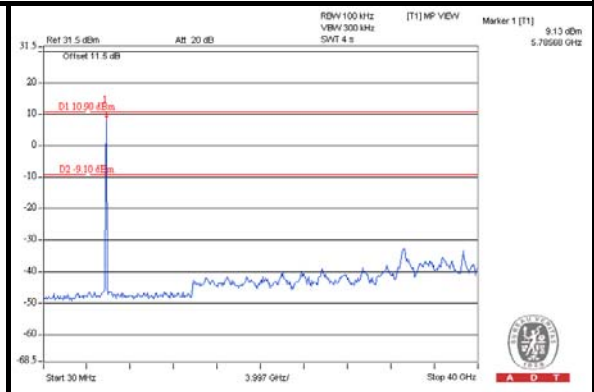
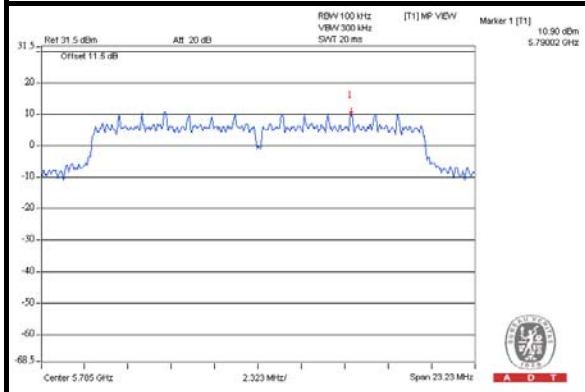
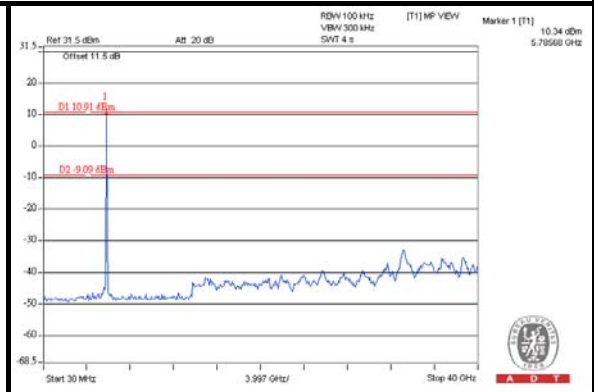
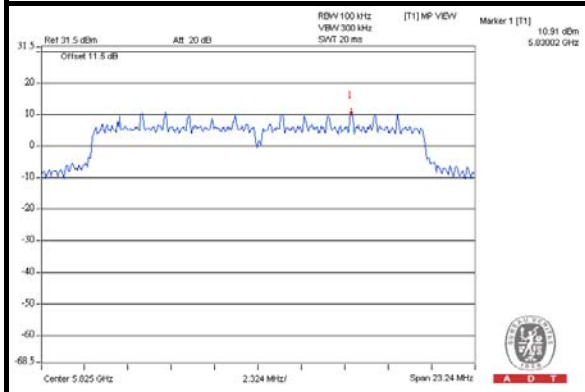
802.11n (20MHz)**CH 149****CH 157****CH 165**



A D T

802.11n (40MHz)

CH 151

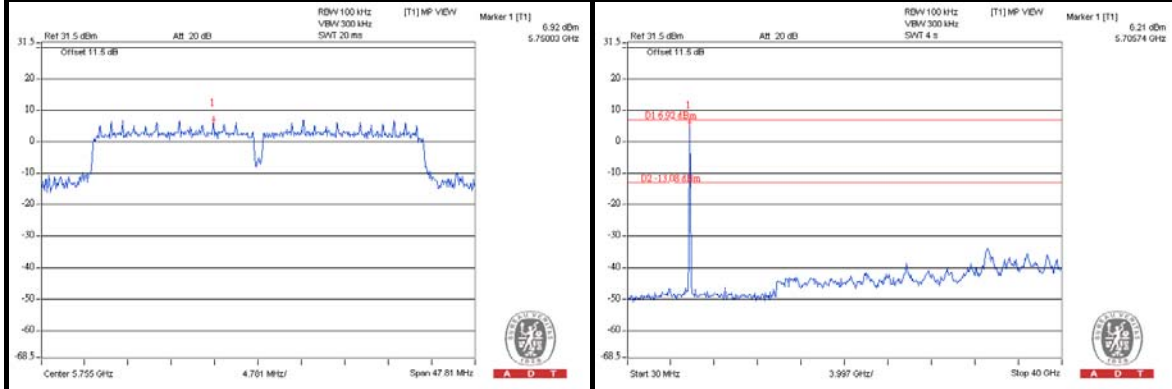

CH 159

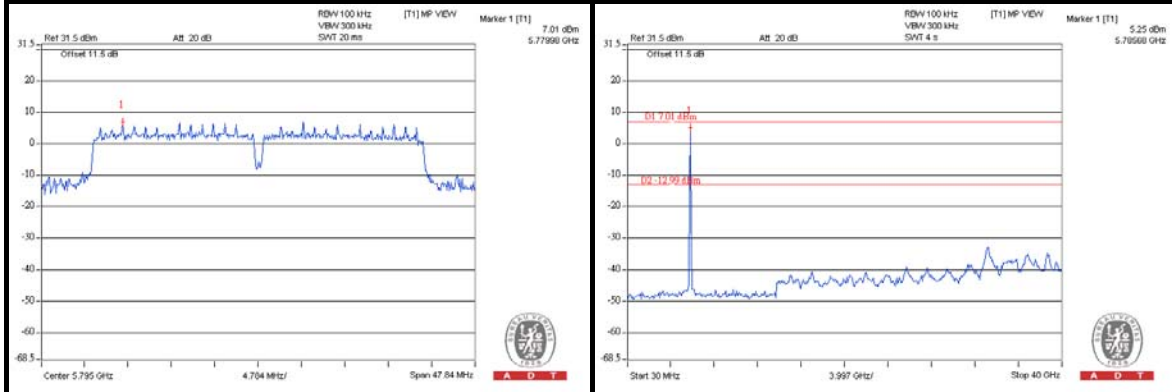



A D T

5. PHOTOGRAPHS OF THE TEST CONFIGURATION

Please refer to the attached file (Test Setup Photo).



A D T

6. INFORMATION ON THE TESTING LABORATORIES

We, Bureau Veritas Consumer Products Services (H.K.) Ltd., Taoyuan Branch, were founded in 1988 to provide our best service in EMC, Radio, Telecom and Safety consultation. Our laboratories are accredited and approved according to ISO/IEC 17025.

If you have any comments, please feel free to contact us at the following:

Linko EMC/RF Lab

Tel: 886-2-26052180

Fax: 886-2-26051924

Hsin Chu EMC/RF Lab

Tel: 886-3-5935343

Fax: 886-3-5935342

Hwa Ya EMC/RF/Safety/Telecom Lab

Tel: 886-3-3183232

Fax: 886-3-3270892

Email: service.adt@tw.bureauveritas.com

Web Site: www.bureauveritas-adt.com

The address and road map of all our labs can be found in our web site also.



A D T

7. APPENDIX A - MODIFICATIONS RECORDERS FOR ENGINEERING CHANGES TO THE EUT BY THE LAB

No modifications were made to the EUT by the lab during the test.

---END---